

ASD TR 61-191 (II)

**THEORETICAL FORMABILITY
VOLUME II
APPLICATION**

*W. W. Wood
et al*

*Manufacturing Research and Development
Vought Aeronautics
a division of
Chance Vought Corporation*

AUGUST 1961

AERONAUTICAL SYSTEMS DIVISION

NOTICES

When Government drawings, specifications, or other data are used for any purpose other than in connection with a definitely related Government procurement operation, the United States Government thereby incurs no responsibility nor any obligation whatsoever; and the fact that the Government may have formulated, furnished, or in any way supplied the said drawings, specifications, or other data, is not to be regarded by implication or otherwise as in any manner licensing the holder or any other person or corporation, or conveying any rights or permission to manufacture, use, or sell any patented invention that may in any way be related hereto.

Qualified requesters may obtain copies of this report from the Armed Services Technical Information Agency, (ASTIA), Arlington Hall Station, Arlington 12, Virginia.

This report has been released to the Office of Technical Services, U. S. Department of Commerce, Washington 25, D. C., for sale to the general public.

Copies of ASD Technical Reports and Technical Notes should not be returned to the Aeronautical Systems Division unless return is required by security considerations, contractual obligations, or notice on a specific document.

HEADQUARTERS

Aeronautical Systems Division

AIR FORCE SYSTEMS COMMAND

UNITED STATES AIR FORCE

WRIGHT-PATTERSON AIR FORCE BASE, OHIO

REPLY TO
ATTN. OF: ASRCTF

4 JAN 1962

SUBJECT: Industrial Opinion of "Theoretical Formability" Program

TO: Illinois Institute of Technology
Metallurgical Engineering
Technology Center
Chicago 16, Illinois

1. As a recipient of the reports of the "Theoretical Formability" Program, your opinion of the overall utility of the effort is requested. These reports are the result of work done by Chance-Vought Aeronautics under Air Force Contract AF 33(616)-6951 and the final reports have been in print approximately three (3) months.
2. It is planned for a more detailed form of questionnaire to be sent out after you have more time to analyze the information and compare or test the theories.
3. At the present time, only your general appraisal of this effort to bring a more theoretical approach to the aircraft sheet metal work is solicited.

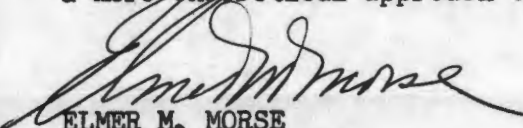

ELMER M. MORSE
Lt. Colonel, USAF
Chief, Fabrication Branch
Manufacturing Technology Laboratory

January 16, 1962

Aeronautical Systems Division
Air Force Systems Command
United States Air Force
Wright-Patterson Air Force Base,
Ohio

Attention: ASRCTF

Subject: Opinion on Theoretical Formability

Dear Sirs:

Your letter of January 4, 1962 inquiring about the readers' reaction to the two "Theoretical Formability Reports", was transmitted to me for comments.

My personal reaction is favorable and there is no doubt that the effort is highly commendable. Much of this work covers areas which were rather neglected owing to their limited scope in some cases or complexity in others.

My critical observations are as follows:

- 1) Author should have made reference tests on some common materials like mild steel and 70/30 brass. In view of the large overall work volume, such small extra would have involved comparatively little effort and yet provided a convenient basis for comparisons.
- 2) A comprehensive theory of deep drawing of cylindrical cups had been developed and checked experimentally by H. W. Swift and his associates. No reference to, or use of his work was made although it is clearly relevant.

I had also difficulties with finding the basic property listings of the experimental materials--an alphabetical index would be handy in volumes of this size.

It seems to me that insofar a "theoretical formability" is concerned, the authors main contribution was to analyze buckling and did a creditable job in this respect.

Yours very truly,

ASD TR 61-191 (II)

**THEORETICAL FORMABILITY
VOLUME II
APPLICATION**

*W. W. Wood
et al*

*Manufacturing Research and Development
Vought Aeronautics
a division of
Chance Vought Corporation*

AUGUST 1961

Directorate of Materials and Processes
Contract No. AF 33(616)-6951
Project No. 7381

AERONAUTICAL SYSTEMS DIVISION
AIR FORCE SYSTEMS COMMAND
UNITED STATES AIR FORCE
WRIGHT-PATTERSON AIR FORCE BASE, OHIO

FOREWORD

This report was prepared by the Manufacturing Research and Development Section, Vought Aeronautics, a division of Chance Vought Corporation, under Contract AF 33(616)-6951. The contract period covered from March 1960 to July 1961 and was administered by the Processes and Exploratory Application Branch, Directorate of Materials and Processes, Deputy for Technology, Aeronautical Systems Division, under the direction of Messrs: C. W. Douglass, G. L. Campbell, and J. M. Bryars. Mr. C. W. Kniffen, Air Force Systems Command, is to be commended for invaluable assistance and guidance in the program.

This report is presented in two volumes. The first volume on development gives the basic theory and the procedure used to accomplish the objective. The second volume on application gives results in handbook form for ready reference.

Mr. W. W. Wood was the project engineer in charge of the program. The research described in this report was conducted under the direction of Mr. G. Gasper, Manufacturing Engineering Manager, and Mr. J. A. Millsap, Chief, Manufacturing Research and Development. Others from the Manufacturing R and D Section who cooperated in the research and in the preparation of the report are: W. W. Akins, R. E. Goforth, R. A. Ford, B. L. Scott, J. N. Lesikar, G. R. DiGiacomo, F. Camden, J. R. Russell, D. L. Norwood, W. D. Moore and C. R. Clifton.

For their assistance in the program, acknowledgement is due to personnel of the Manufacturing R and D Laboratory, Production Sheet Metal Fabrication, Structures Test Laboratory, and Technical Publications sections who participated in the research work throughout the program.

The Fort Worth Division of Convair performed all the experimental work for the Androform process.

ABSTRACT

The "cut-and-try" method of determining sheet metal formability has long been the standard practice in the aircraft industry. This two-volume report presents methods of determining formability analytically for the twelve most common processes of forming sheet metal. This method is based on utilization of a material's mechanical properties to predict formability.

The first volume on development gives the procedure used to arrive at the objective of predicting formability. First, basic limit equations are developed relating geometry of the parts to the material properties. These equations are used to determine the shape of the limit graphs and to give indices relating formability to the material. Then, experimental parts are formed to position the theoretically shaped curves with the aid of the formability indices.

The second volume on application is presented in handbook form giving design and manufacturing information for the nineteen materials in the program. These materials covered some of the most currently used alloys in the following categories: (1) magnesium, (2) aluminum, (3) titanium, (4) stainless steel, (5) tool steel, (6) nickel and cobalt base, and (7) the refractory metals. Graphs, equations, and design tables are presented for each process, statistically proven with experimental work comprising a total of approximately twenty-one-thousand formed parts.

PUBLICATION REVIEW

This report has been reviewed and is approved.

FOR THE COMMANDER:

J. TERES
Technical Director
Applications Laboratory
Directorate of Materials
and Processes

y

TABLE OF CONTENTS

<u>Section</u>	<u>Page</u>
INTRODUCTION	1
I. BENDING	
A. BRAKE FORMING	I-1
Description of Process	I-1
Definition of Part Shape and Geometric Variables	I-3
Predictability Equations	I-5
Composite Graphs	I-10
Design Tables	I-16
B. JOGGLING	I-40
Description of Process	I-41
Definition of Part Shape and Geometric Variables	I-43
Predictability Equations	I-45
Composite Graphs	I-51
Design Tables	I-56
II. FLANGING	
A. DIMPLING	II-1
Description of Process	II-1
Definition of Part Shape and Geometric Variables	II-4
Predictability Equations	II-5
Composite Graphs	II-6
Design Tables	II-8

TABLE OF CONTENTS (Contd.)

<u>Section</u>	<u>Page</u>
B. RUBBER FORMING SHRINK AND STRETCH FLANGES	II-10
Description of Process	II-10
Definition of Part Shape and Geometric Variables	II-12
Predictability Equations	II-13
Composite Graphs	II-20
Design Tables	II-27
III. LINEAR CONTOURING OF SECTIONS	
A. LINEAR STRETCH FORMING	III-1
Description of Process	III-1
Definition of Part Shape and Geometric Variables	III-2
Predictability Equations	III-4
Composite Graphs	III-7
Design Tables	III-17
LINEAR ROLL FORMING	III-73
Description of Process	III-73
Definition of Part Shape and Geometric Variables	III-79
Predictability Equations	III-80
Composite Graphs	III-85
Design Tables	III-90
IV. PLANE CONTOURING OF SHEET	
A. SHEET STRETCH FORMING	IV-1
Description of Process	IV-1

TABLE OF CONTENTS (Contd.)

<u>Section</u>	<u>Page</u>
SHEET STRETCH FORMING (Contd.)	
Definition of Part Shape and Geometric Variables	IV-2
Predictability Equations	IV-4
Composite Graphs	IV-9
Design Tables	IV-12
B. ANDROFORMING	IV-31
Description of Process	IV-31
Definition of Part Shape and Geometric Variables	IV-34
Predictability Equations	IV-35
Composite Graphs	IV-41
Design Tables	IV-47
V. DEEP RECESSING	
A. DEEP DRAWING WITH MECHANICAL DIES	V-1
Description of the Forming Process	V-1
Definition of Part Shape and Geometric Variables	V-4
Predictability Equations	V-7
Composite Graphs	V-10
Design Tables	V-15
B. MANUAL SPINNING	V-25
Description of the Forming Process	V-25
Definition of Part Shape and Geometric Variables	V-26

TABLE OF CONTENTS (Contd.)

<u>Section</u>	<u>Page</u>
MANUAL SPINNING (Contd.)	
Predictability Equations	V-29
Composite Graphs	V-33
Design Tables	V-38
VI. SHALLOW RECESSING	
A. BEADING ON THE RUBBER PRESS	VI-1
Description of Process	VI-1
Definition of Part Shape and Geometric Variables	VI-2
Predictability Equations	VI-3
Composite Graphs	VI-7
Design Tables	VI-10
B. BEADING ON THE DROP HAMMER	VI-27
Description of Process	VI-27
Definition of Part Shape and Geometric Variables	VI-30
Predictability Equations	VI-33
Composite Graphs	VI-37
Design Tables	VI-42

LIST OF FIGURES

<u>Figure</u>		<u>Page</u>
BRAKE FORMING		
IA-1	Typical Brake Forming Setup	I-1
IA-2	Graphical Die Opening Values	I-2
IA-3	Effect of Varying R/t Values	I-3
IA-4	Effect of Part Angle on R/t Value	I-4
IA-5	Effect of Direction of Roll on Bending	I-5
IA-6	Typical Gridded Tension Specimen	I-7
IA-7	Splitting Limit Curve for Brake Forming	I-9
IA-8	Recommended Tensile Specimen Gages for Brake Forming Correlation	I-12
JOGGLING		
IB-1	Schematic of Joggle Dies	I-42
IB-2	Geometrical Parameters of a Joggle	I-44
IB-3	Typical Jogging Formability Curve	I-46
IB-4	Splitting Limit Line	I-47
IB-5	Graph Construction	I-48
IB-6	Typical Formability Envelope	I-49
IB-7	Graph Construction	I-50
IB-8	Graph Construction	I-50
IB-9	Variation of Material Properties	I-51
IB-10	Splitting Limit Line	I-52
DIMPLING		
IIA-1	Cross Section of Ram Coin Dimpling	II-1
IIA-2	Cross Section of Ram Coin Dimpling	II-2
IIA-3	Cross Section of Ram Coin Dimpling	II-3

LIST OF FIGURES (Contd.)

<u>Figure</u>		<u>Page</u>
IIA-4	Cross Section of Ram Coin Dimpling	II-3
IIA-5	Cross Section of Dimple Showing Geometric Parameters	II-5
IIA-6	Formability Graph Construction	II-5
IIA-7	Formability Curve for 2024-T3 Aluminum	II-6
RUBBER FORMING		
IIB-1	The Guerin Rubber Process, 1925 PSI Lake Erie Rubber Press	II-11
IIB-2	Rubber Shrink and Stretch Parts	II-12
IIB-3	Graph Construction	II-15
IIB-4	Graph Construction	II-16
IIB-5	Graph Construction	II-17
IIB-6	Graph Construction	II-18
IIB-7	Graph Construction	II-19
IIB-8	Typical Formability Curve	II-20
IIB-9	Absolute and Extended Rubber Shrink Formability Limits	II-22
IIB-10	Possible Range in Formability Curves	II-23
LINEAR STRETCH FORMING		
IIIA-1	Linear Stretch Form Process	III-1
IIIA-2	Heel-Out Angle	III-2
IIIA-3	Heel-Out Channel	III-2
IIIA-4	Heel-In Angle	III-3
IIIA-5	Heel-In Channel	III-3
IIIA-6	Heel-In Hat Section	III-3

LIST OF FIGURES (Contd.)

<u>Figure</u>		<u>Page</u>
IIIA-7	Equation Application for Class 1 Formability Limit Curves	III-6
IIIA-8	Equation Application for Class 2 and Class 3 Formability Limit Curves	III-6
IIIA-9	Satisfactory Formability	III-7
IIIA-10	Unsatisfactory Formability	III-7
IIIA-11	Log Type Formability Limit Curve	III-8
IIIA-12	Cartesian Type Formability Limit Curve	III-9
IIIA-13	Effect of Mechanical Property Variation on Formability	III-9
IIIA-14	Spring Back Due to Large Bend Radii	III-10
IIIA-15	Column Collapse Due to Large Bend Radii	III-10
IIIA-16	Heel-Out Angle	III-19
IIIA-17	Heel-Out Channel	III-19
IIIA-18	Heel-In Angle	III-37
IIIA-19	Heel-In Channel	III-37
IIIA-20	Heel-In Hat Sections	III-55
LINEAR ROLL FORMING		
IIIB-1	Linear Roll Tooling	III-73
IIIB-2	Linear Roll Heel-In Machine Set-Up	III-76
IIIB-3	Heel-In Channel Distortion	III-77
IIIB-4	Linear Roll Heel-In and Heel-Out Channels	III-79
IIIB-5	Graph Construction	III-82
IIIB-6	Graph Construction	III-83
IIIB-7	Typical Formability Curve	III-84

LIST OF FIGURES (Contd.)

<u>Figure</u>		<u>Page</u>
IIIB-8	Graph Construction	III-85
IIIB-9	Heel-In Channel Distortion	III-90
SHEET STRETCH		
IVA-1	Typical Sheet Stretch Setup	IV-1
IVA-2	Geometric Variables of Sheet Stretch	IV-3
IVA-3	Setup Considering the Direction of Roll of The Material	IV-3
IVA-4	Typical Gridded Tension Specimen	IV-5
IVA-5	Plotting Equation II	IV-6
IVA-6	Finding the R/L Value	IV-7
IVA-7	Plotting Index and Theoretical Limits	IV-8
IVA-8	Plotting the Forming Limits	IV-8
ANDROFORMING		
IVB-1	Androform Components	IV-32
IVB-2	Machine Adjustments for Androforming	IV-33
IVB-3	Geometric Variables for Androforming	IV-34
IVB-4	Splitting Limit Curve	IV-37
IVB-5	Buckling Limit Curve	IV-37
IVB-6	Procedure for Finding the Splitting Limit	IV-38
IVB-7	Procedure for Finding the Buckling Limit	IV-40
DEEP DRAWING		
VA-1	Double Action Draw Die	V-1
VA-2	Single Action Draw Die	V-3
VA-3	Geometrical Variables for Cupping	V-4

LIST OF FIGURES (Contd.)

<u>Figure</u>		<u>Page</u>
VA-4	Typical Theoretical Formability Curve for Thin Walled Cylindrical Cups	V-5
VA-5	Typical Formability Curve Showing a Constant R_d/t Line	V-6
VA-6	Typical Formability Curves Illustrating the Position of Various Materials.....	V-7
VA-7	Typical Formability Curve and Index Lines	V-9
VA-8	Sample Construction of the Theoretical Formability Limit Curve for Tungsten at 1000 ^o F.....	V-10
VA-9	Materials Requiring Special Mention	V-11
VA-10	Curve for Converting from Overhang (h) To Final Cup Height (H)	V-15
VA-11	Cup Wall Tension Vs. Blank Holder Pressure	V-16
VA-12	Formability Limit Increase From Reduced Blank Holder Pressure	V-17
MANUAL SPINNING		
VB-1	A Single Stage Setup for Manual Spinning	V-25
VB-2	Geometric Variables for Spinning	V-27
VB-3	Theoretical Formability Curve for Spinning	V-28
VB-4	Forming Limit Curves for Spinning Showing Machine Limits	V-29
VB-5	Plastic and Elastic Limits	V-30
VB-6	Machine Limit Curves for Spinning	V-32
VB-7	Predictability Equation for Spinning in Graph Form	V-32
VB-8	Curve for Converting From Overhang (h) to Final Cup Height (H)	V-38

LIST OF FIGURES (Contd.)

<u>Figure</u>		<u>Page</u>
RUBBER BEAD FORMING		
VIA-1	Cross-Section and Side View of Bead	VI-3
VIA-2	Graph Construction	VI-4
VIA-3	Graph Construction	VI-5
VIA-4	Graph Construction	VI-6
VIA-5	Typical Formability Curve	VI-6
VIA-6	Range in Formability Limits	VI-7
DROP HAMMER BEAD FORMING		
VIB-1	Drop Hammer Setup	VI-27
VIB-2	Typical Kirksite Beaded Panel Dies	VI-28
VIB-3	Cross Section of a Drop Hammer Die	VI-29
VIB-4	Geometric Parameters	VI-30
VIB-5	Relationship of Bead Spacing	VI-31
VIB-6	Bead	VI-32
VIB-7	Typical Drop Hammer Formability Curve	VI-33
VIB-8	1/2" Wide Tensile Specimen	VI-34
VIB-9	Graph Construction	VI-35
VIB-10	Graph Construction	VI-36
VIB-11	Typical Formability Envelope	VI-37
VIB-12	Variation of Material Properties	VI-38
VIB-13	Schematic of a Punch and Bead	VI-42

LIST OF GRAPHS

<u>Graph</u>		<u>Page</u>
BRAKE FORMING		
IA-1	Composite Room Temperature Splitting Limits for Brake Forming.....	I-13
IA-2	Brake Forming Splitting Limit at Elevated Temperatures.....	I-14
IA-3	Splitting Correlation Curves for Brake Forming at Room Temperature	I-15
JOGGLING		
IB-1	Composite Graph for Jogging	I-54
IB-2	Jogging Limits for 2024-O Aluminum.....	I-55
DIMPLING		
IIA-1	Composite Curves for Dimpling.....	II-7
RUBBER FORMING		
IIB-1	Composite Graph for Rubber Stretch Flanges.....	II-24
IIB-2	Composite Graph for Rubber Shrink Flanges.....	II-25
IIB-3	Alternate Method of Plotting Rubber Stretch Formability Limits 2024-O Aluminum	II-26
LINEAR STRETCH		
IIIA-1	Linear Stretch Composite Graph Heel-Out Angles and Channels.....	III-13
IIIA-2	Linear Stretch Composite Graph Heel-In Angles and Channels.....	III-14
IIIA-3	Linear Stretch Composite Graph Heel-In Hat Sections.....	III-15
IIIA-4	Linear Stretch Formability Limits Heel-In Angles and Channels 2024-O Aluminum	III-16

LIST OF GRAPHS (Contd.)

<u>Graph</u>	<u>Page</u>
LINEAR ROLL	
IIIB-1	Linear Roll Composite Graph Heel-In Channels..... III-87
IIIB-2	Linear Roll Composite Graph Heel-Out Channels..... III-88
IIIB-3	Alternate Method for Plotting Linear Roll Heel-In 17-7 PH (Condition A)..... III-89
SHEET STRETCH	
IVA-1	Sheet Stretch Correlation Graph..... IV-10
IVA-2	Sheet Stretch Composite Graph for Forming Limits..... IV-11
ANDROFORMING	
IVB-1	Composite Graph for Androform Splitting Limits for (50" forming element)..... IV-42
IVB-2	Composite Graph for Androform Buckling Limits for (50" forming element)..... IV-43
IVB-3	Composite Graph for Androform Splitting Limits for (20" forming element)..... IV-44
IVB-4	Composite Graph for Androform Buckling Limits for (20" forming element)..... IV-45
IVB-5	Alternate Method of Plotting Androform Limits (2024-T4 Aluminum)..... IV-46
DEEP DRAWING	
VA-1	Composite Graph of Deep Draw Limits for Cylindrical Cups V-13
VA-2	Alternate Method of Plotting Deep Draw Formability Limits 2024-O Aluminum..... V-14

LIST OF GRAPHS (Contd.)

<u>Graph</u>		<u>Page</u>
MANUAL SPINNING		
VB-1	Spinning Composite for Elastic and Plastic Buckling Limits	V-34
VB-2	Composite Graph of Machine Limit Index Lines II.....	V-35
VB-3	Manual Spinning Machine Gage Limits 2024-0 Aluminum	V-36
VB-4	Alternate Method of Plotting Spinning Formability Limits 2024-0 Aluminum	V-37
RUBBER BEADING		
VIA-1	Composite Graph for Rubber Bead Panels	VI-8
VIA-2	Alternate Method of Plotting Rubber Bead Forming Limits - 2024-0 Aluminum	VI-9
DROP HAMMER BEADING		
VIB-1	Composite Graph for Drop Hammer Beaded Panels	VI-40
VIB-2	Drop Hammer Bead Limit 2024-0 Aluminum	VI-41

LIST OF DESIGN TABLES

<u>Table</u>		<u>Page</u>
	BRAKE FORMING - MINIMUM BEND RADIUS LIMITS	
IA-1	HM21XA-T8 (Magnesium Thorium) Longitudinal and Transverse Grain Direction	I-17
IA-2	2024-0 Aluminum Longitudinal and Transverse Grain Direction	I-18
IA-3	17-7 PH (Condition "A", Mill Annealed) Longitudinal and Transverse Grain Direction	I-19
IA-4	PH 15-7 Mo (Condition "A", Mill Annealed) Longitudinal and Transverse Grain Direction	I-20
IA-5	AM-350 (Annealed) Longitudinal and Transverse Grain Direction	I-21
IA-6	A-286 (Solution Treated Condition) Longitudinal and Transverse Grain Direction	I-22
IA-7	USS 12 MoV (Annealed) Longitudinal and Transverse Grain Direction	I-23
IA-8	Titanium (6Al-4V) (Mill Annealed) Longitudinal and Transverse Grain Direction	I-24
IA-9	Titanium (13V-11Cr-3Al) (Solution Treated) Longitudinal and Transverse Grain Direction	I-25
IA-10	Vascojet 1000 (H-11) (Annealed) Longitudinal and Transverse Grain Direction	I-26
IA-11	Rene'41 (Solution Treated) Longitudinal Grain Direction	I-27
IA-12	Rene'41 (Solution Treated) Transverse Grain Direction	I-28
IA-13	Inconel X (C.R. Annealed) Longitudinal and Transverse Grain Direction	I-29
IA-14	Hastelloy X (Solution Treated) Longitudinal and Transverse Grain Direction	I-30
IA-15	L-605 (Solution Treated) Longitudinal and Transverse Grain Direction	I-31

LIST OF DESIGN TABLES (Contd.)

<u>Table</u>		<u>Page</u>
IA-16	J-1570 (Solution Treated) Longitudinal Grain Direction	I-32
IA-17	J-1570 (Solution Treated) Transverse Grain Direction	I-33
IA-18	Molybdenum (.5% Ti) (Hot Rolled, Stress Relieved, De-scaled Sheet) Longitudinal Grain Direction	I-34
IA-19	Molybdenum (.5% Ti) (Hot Rolled, Stress Relieved, De-scaled Sheet) Transverse Grain Direction	I-35
BRAKE FORMING - MINIMUM BEND RADIUS LIMITS AT ELEVATED TEMPERATURES		
IA-20	HM21XA-T8(Magnesium Thorium) Longitudinal and Transverse Grain Direction	I-36
IA-21	Beryllium (Pure) (Condition "C") Longitudinal Grain Direction	I-37
IA-22	Beryllium (Pure) (Condition "C") Transverse Grain Direction	I-38
IA-23	Tungsten (Pure) 0.020 Gage, Longitudinal and Transverse Grain Direction	I-39
IA-24	Tungsten (Pure) 0.040 Gage, Longitudinal and Transverse Grain Direction	I-40
JOGGLING DEPTH LIMITS		
IB-1	HM21XA-T8 (Magnesium Thorium) - Temperature 750°F....	I-57
IB-2	2024-0 Aluminum	I-58
IB-3	17-7 Ph Stainless Steel (Mill Annealed, Condition "A")	I-59
IB-4	Ph 15-7 Mo Stainless Steel (Mill Annealed, Condition "A")	I-60
IB-5	AM-350 Stainless Steel (Annealed)	I-61
IB-6	A-286 Stainless Steel (Solution Treated Condition)...	I-62

LIST OF DESIGN TABLES (Contd.)

<u>Table</u>		<u>Page</u>
IB-7	USS-12-MoV Stainless Steel (Annealed)	I-63
IB-8	Titanium (13V-11Cr-3Al) (Solution Treated Condition)	I-64
IB-9	Vascojet 1000 (H-11) (Annealed)	I-65
IB-10	Beryllium (Pure) (Condition "C", Temperature 1200°F)	I-66
IB-11	Rene '41 (Solution Treated Condition)	I-67
IB-12	Inconel X (C.R. Annealed)	I-68
IB-13	Hastelloy X (Solution Treated)	I-69
IB-14	L-605 (Solution Treated)	I-70
IB-15	J-1570 (Solution Treated)	I-71
IB-16	Columbium (10 Mo-10 Ti)	I-72
IB-17	Molybdenum (.5% Ti) (Hot Rolled, Stress Relieved, De-scaled Sheet)	I-73
IB-18	Tungsten (Pure) Temperature 1000°F	I-74
DIMPLING		
IIA-1	Design Tables for Dimpling	II-9
RUBBER FORMING LIMITS STRETCH FLANGES		
IIB-1	HM21XA-T8 (Magnesium Thorium)	II-28
IIB-2	2024-O Aluminum	II-29
IIB-3	17-7 PH (Condition A)	II-30
IIB-4	PH 15-7 Mo (Condition A)	II-31
IIB-5	AM-350 (Annealed)	II-32
IIB-6	A-286 (Solution Treated)	II-33
IIB-7	USS-12-MoV (Annealed)	II-34

LIST OF DESIGN TABLES (Contd.)

<u>Table</u>		<u>Page</u>
IIB-8	Titanium (6Al-4V) (Mill Annealed)	II-35
IIB-9	Titanium (13V-11Cr-3Al) (Solution Treated)	II-36
IIB-10	Vascojet 1000 (H-11) (Annealed)	II-37
IIB-11	Rene '41 (Solution Treated)	II-38
IIB-12	Inconel X (C.R. Annealed)	II-39
IIB-13	Hastelloy X (Solution Treated)	II-40
IIB-14	L-605 (Solution Treated)	II-41
IIB-15	J-1570 (Solution Treated)	II-42
IIB-16	Columbium (10 Mo-10 Ti)	II-43
IIB-17	Molybdenum (.5% Ti)	II-44
RUBBER FORMING LIMITS SHRINK FLANGES		
IIB-18	HM21XA-T8 (Magnesium Thorium)	II-45
IIB-19	2024-0 Aluminum	II-46
IIB-20	17-7 PH (Condition A)	II-47
IIB-21	PH 15-7 Mo (Condition A)	II-48
IIB-22	AM-350 (Annealed)	II-49
IIB-23	A-286 (Solution Treated)	II-50
IIB-24	USS-12-MoV (Annealed)	II-51
IIB-25	Titanium (6Al-4V) (Mill Annealed)	II-52
IIB-26	Titanium (13V-11Cr-3Al) (Solution Treated)	II-53
IIB-27	Vascojet 1000 (H-11) (Annealed)	II-54
IIB-28	Rene '41 (Solution Treated)	II-55
IIB-29	Inconel X (C.R. Annealed)	II-56

LIST OF DESIGN TABLES (Contd.)

<u>Table</u>		<u>Page</u>
IIB-30	Hastelloy X (Solution Treated)	II-57
IIB-31	L-605 (Solution Treated)	II-58
IIB-32	J-1570 (Solution Treated)	II-59
IIB-33	Columbium (10 Mo-10 Ti)	II-60
IIB-34	Molybdenum (.5% Ti)	II-61
LINEAR STRETCH FORMING LIMITS HEEL-OUT ANGLES AND CHANNELS		
IIIA-1	HM21XA-T8 (Magnesium Thorium) (400°F-600°F)	III-20
IIIA-2	2024-O Aluminum	III-21
IIIA-3	17-7 PH (Condition A, Mill Annealed)	III-22
IIIA-4	PH 15-7 Mo (Condition A)	III-23
IIIA-5	AM-350 (Annealed)	III-24
IIIA-6	A-286 (Solution Treated)	III-25
IIIA-7	USS-12-MoV (Annealed)	III-26
IIIA-8	Titanium (6Al-4V) (Mill Annealed)	III-27
IIIA-9	Titanium (13V-11Cr-3Al) (Solution Treated)	III-28
IIIA-10	Vascojet 1000 (H-11) (Annealed)	III-29
IIIA-11	Rene '41 (Solution Treated)	III-30
IIIA-12	Inconel X (C.R. Annealed)	III-31
IIIA-13	Hastelloy X (Solution Treated)	III-32
IIIA-14	L-605 (Solution Treated)	III-33
IIIA-15	Columbium (10 Mo-10 Ti)	III-34
IIIA-16	Molybdenum (.5% Ti) (Hot Rolled, Stress Relieved and De-scaled)	III-35
IIIA-17	J-1570 (Solution Treated)	III-36

LIST OF DESIGN TABLES (Contd.)

<u>Table</u>		<u>Page</u>
	LINEAR STRETCH FORMING LIMITS HEEL-IN ANGLES AND CHANNELS	
IIIA-18	HM21XA-T8 (Magnesium Thorium) (400 °F-600 °F)	III-38
IIIA-19	2024-O Aluminum	III-39
IIIA-20	17-7 PH (Condition A, Mill Annealed)	III-40
IIIA-21	PH 15-7 Mo (Condition A)	III-41
IIIA-22	AM-350 (Annealed)	III-42
IIIA-23	A-286 (Solution Treated)	III-43
IIIA-24	USS-12-MoV (Annealed)	III-44
IIIA-25	Titanium (6Al-4V) (Mill Annealed)	III-45
IIIA-26	Titanium (13V-11Cr-3Al) (Solution Treated)	III-46
IIIA-27	Vascojet 1000 (H-11) (Annealed)	III-47
IIIA-28	Rene '41 (Solution Treated)	III-48
IIIA-29	Inconel X (C.R. Annealed)	III-49
IIIA-30	Hastelloy X (Solution Treated)	III-50
IIIA-31	L-605 (Solution Treated)	III-51
IIIA-32	Columbium (10 Mo-10 Ti)	III-52
IIIA-33	Molybdenum (.5% Ti) (Hot Rolled, Stress Relieved and De-scaled)	III-53
IIIA-34	J-1570 (Solution Treated)	III-54
	LINEAR STRETCH FORMING LIMITS HEEL-IN HAT SECTIONS	
IIIA-35	HM21XA-T8 (Magnesium Thorium) (400 °F-600 °F)	III-56
IIIA-36	2024-O Aluminum	III-57
IIIA-37	17-7 PH (Condition A, Mill Annealed)	III-58

LIST OF DESIGN TABLES (Contd.)

<u>Table</u>		<u>Page</u>
IIIA-38	PH 15-7 Mo (Condition A)	III-59
IIIA-39	AM-350 (Annealed)	III-60
IIIA-40	A-286 (Solution Treated)	III-61
IIIA-41	USS-12-MoV (Annealed)	III-62
IIIA-42	Titanium (6Al-4V) (Mill Annealed)	III-63
IIIA-43	Titanium (13V-11Cr-3Al) (Solution Treated)	III-64
IIIA-44	Vascojet 1000 (H-11)(Annealed)	III-65
IIIA-45	Rene '41 (Solution Treated)	III-66
IIIA-46	Inconel X (C.R. Annealed)	III-67
IIIA-47	Hastelloy X (Solution Treated)	III-68
IIIA-48	L-605 (Solution Treated)	III-69
IIIA-49	Columbium (10 Mo-10 Ti)	III-70
IIIA-50	Molybdenum (.5% Ti) (Hot Rolled, Stress Relieved and De-scaled)	III-71
IIIA-51	J-1570 (Solution Treated)	III-72
LINEAR ROLL FORMING LIMITS HEEL-IN CHANNELS		
IIIB-1	HM21XA-T8 (Magnesium Thorium)	III-93
IIIB-2	2024-0 Aluminum	III-94
IIIB-3	17-7 PH (Condition A)	III-95
IIIB-4	PH 15-7 Mo (Condition A)	III-96
IIIB-5	AM-350 (Annealed)	III-97
IIIB-6	A-286 (Solution Treated)	III-98
IIIB-7	USS-12-MoV (Annealed)	III-99
IIIB-8	Titanium (6Al-4V) (Mill Annealed)	III-100

LIST OF DESIGN TABLES (Contd.)

<u>Table</u>		<u>Page</u>
IIIB-9	Titanium (13V-11Cr-3Al) (Solution Treated)	III-101
IIIB-10	Vascojet 1000 (H-11)(Annealed)	III-102
IIIB-11	Rene '41 (Solution Treated)	III-103
IIIB-12	Inconel X (C.R. Annealed)	III-104
IIIB-13	Hastelloy X (Solution Treated)	III-105
IIIB-14	L-605 (Solution Treated)	III-106
IIIB-15	J-1570 (Solution Treated)	III-107
IIIB-16	Columbium (10 Mo-10 Ti)	III-108
IIIB-17	Molybdenum (.5% Ti)	III-109
LINEAR ROLL FORMING LIMITS HEEL-OUT CHANNELS		
IIIB-18	HM21XA-T8 (Magnesium Thorium)	III-110
IIIB-19	2024-O Aluminum	III-111
IIIB-20	17-7 PH (Condition A)	III-112
IIIB-21	PH 15-7 Mo (Condition A)	III-113
IIIB-22	AM-350 (Annealed)	III-114
IIIB-23	A-286 (Solution Treated)	III-115
IIIB-24	USS-12-MoV (Annealed)	III-116
IIIB-25	Titanium (6Al-4V) (Mill Annealed)	III-117
IIIB-26	Titanium (13V-11Cr-3Al) (Solution Treated).....	III-118
IIIB-27	Vascojet 1000 (H-11) (Annealed)	III-119
IIIB-28	Rene '41 (Solution Treated)	III-120
IIIB-29	Inconel X (C.R. Annealed)	III-121
IIIB-30	Hastelloy X (Solution Treated)	III-122

LIST OF DESIGN TABLES (Contd.)

<u>Table</u>		<u>Page</u>
IIIB-31	L-605 (Solution Treated)	III-123
IIIB-32	J-1570 (Solution Treated)	III-124
IIIB-33	Columbium (10 Mo-10 Ti)	III-125
IIIB-34	Molybdenum (.5% Ti)	III-126

SHEET STRETCH - FORMING LIMITS FOR

IVA-1	HM21XA-T8 (Magnesium Thorium Alloy)	IV-13
IVA-2	HM21XA-T8 (Magnesium Thorium at 750 °F)	IV-14
IVA-3	2024-0 Aluminum	IV-15
IVA-4	17-7 PH (Condition "A", Mill Annealed)	IV-16
IVA-5	PH 15-7 Mo (Condition "A", Mill Annealed)	IV-17
IVA-6	AM-350 (Annealed)	IV-18
IVA-7	A-286 (Solution Treated Condition)	IV-19
IVA-8	USS-12-MoV (Annealed)	IV-20
IVA-9	Titanium (6Al-4V) (Mill Annealed)	IV-21
IVA-10	Titanium (13V-11Cr-3Al) (Solution Treated)	IV-22
IVA-11	Vascojet 1000 (H-11) (Annealed)	IV-23
IVA-12	Rene '41 (Solution Treated)	IV-24
IVA-13	Inconel X (C.R. Annealed)	IV-25
IVA-14	Hastelloy X (Solution Treated)	IV-26
IVA-15	L-605 (Solution Treated)	IV-27
IVA-16	J-1570 (Solution Treated)	IV-28
IVA-17	Molybdenum (.5% Ti) (Hot Rolled, Stress Relieved, De-scaled Sheet)	IV-29
IVA-18	Columbium (10 Mo-10 Ti)	IV-30

LIST OF DESIGN TABLES (Contd.)

<u>Table</u>		<u>Page</u>
ANDROFORM LIMITS		
IVB-1	HM21XA-T8 (Magnesium Thorium)	IV-48
IVB-2	2024-T4 Aluminum	IV-49
IVB-3	17-7 PH (Stainless Steel) (Condition TH 1050)	IV-50
IVB-4	PH 15-7 Mo (Stainless Steel) (Condition TH 1050)	IV-51
IVB-5	AM-350 (Stainless Steel) (Age Hardened at 850°F)	IV-52
IVB-6	A-286 (Stainless Steel) (Age Hardened at 1325°F)	IV-53
IVB-7	USS-12-MoV (Stainless Steel) (Age Hardened at 800°F)	IV-54
IVB-8	Titanium (6Al-4V) (Solution Treated)	IV-55
IVB-9	Titanium (13V-11Cr-3Al) (Age Hardened 900°F)	IV-56
IVB-10	Vascojet 1000 (H-11) (Hardened)	IV-57
IVB-11	Rene '41 (Age Hardened at 1400°F)	IV-58
IVB-12	Inconel X (Age Hardened at 1300°F)	IV-59
IVB-13	Hastelloy X (Solution Treated Condition)	IV-60
IVB-14	L-605 (Solution Treated)	IV-61
IVB-15	Columbium (10 Mo-10 Ti)	IV-62
IVB-16	Molybdenum (.5% Ti) (Hot Rolled, Stress Relieved, De-scaled Sheet)	IV-63
DEEP DRAWING LIMITS FOR CYLINDRICAL CUPS		
VA-1	17-7 PH (Annealed, Condition "A").....	V-18
VA-2	A-286 (Solution Treated, USS-12-MoV at 800°F (Annealed) Inconel X (C.R. Annealed), J-1570 (Solution Treated)	V-19

LIST OF DESIGN TABLES (Contd.)

<u>Table</u>		<u>Page</u>
VA-3	2024-0 Aluminum PH 15-7 Mo (Annealed, Condition "A") AM-350 (Annealed) Rene '41 (Solution Treated) Hastelloy X (Solution Treated) L-605 (Solution Treated)	V-20
VA-4	HM21XA-T8 at 750°F, USS-12-MoV (Annealed), Molybdenum (.5% Ti) (Hot Rolled, Stress Relieved) (900°F)	V-21
VA-5	Vascojet 1000 (H-11) (Annealed) Vascojet 1000,(800°F)(H-11) (Annealed) Tungsten (Pure) 1000°F	V-22
VA-6	Columbium (10 Mo-10 Ti) at 500°F	V-23
VA-7	Titanium (6Al-4V) (Annealed) Titanium (13V-11Cr-3Al) (Solution Treated)	V-24
MANUAL SPINNING FORMING LIMITS FOR CYLINDRICAL CUPS		
VB-1	HM21XA-T8 (Magnesium Thorium)	v-40
VB-2	2024-0 Aluminum	V-41
VB-3	17-7 PH Mill Annealed (Condition "A")	V-42
VB-4	PH 15-7 Mo (Mill Annealed, Condition "A")	V-43
VB-5	AM-350 Stainless Steel (Annealed)	V-44
VB-6	A-286 Stainless Steel (Solution Treated Condition)...	V-45
VB-7	USS-12-MoV Stainless Steel (Annealed)	V-46
VB-8	Titanium (6Al-4V) (Mill Annealed)	V-47
VB-9	Titanium (13V-11Cr-3Al) (Solution Treated Condition)	V-48
VB-10	Vascojet 1000 (H-11) (Annealed).....	V-49

LIST OF DESIGN TABLES (Cont'd)

Table		Page
VB-11	Beryllium (Pure) (Condition "C") (Temp. 1200 °F).....	V-50
VB-12	Rene '41 (Solution Treated)	V-51
VB-13	Inconel X (C.R. Annealed)	V-52
VB-14	Hastelloy X (Solution Treated)	V-53
VB-15	L-605 (Solution Treated)	V-54
VB-16	J-1570 (Solution Treated)	V-55
VB-17	Columbium (10 Mo-10 Ti)	V-56
VB-18	Molybdenum (.5% Ti) (Hot Rolled, Stress Relieved, De-scaled Sheet) Temperature 850 °F.....	V-57
VB-19	Tungsten (Pure) Temperature 1700 °F	V-58
VB-20	HM21XA-T8 (Magnesium Thorium) (750 °F)	V-59
VB-21	USS-12-MoV (Annealed) Temperature 750 °F	V-60
VB-22	Vascojet 1000 (H-11) (Annealed) Temperature 750 °F....	V-61
VB-23	Columbium (10 Mo-10 Ti) Temperature 750 °F	V-62

RUBBER BEAD FORMING LIMITS

VIA-1	2024-O Aluminum	VI-12
VIA-2	17-7 PH (Condition "A")	VI-13
VIA-3	PH 15-7 Mo (Condition "A")	VI-14
VIA-4	AM-350 (Annealed)	VI-15
VIA-5	A-286 (Solution Treated)	VI-16
VIA-6	USS-12-MoV (Annealed)	VI-17
VIA-7	Titanium (13V-11Cr-3Al) (Solution Treated)	VI-18
VIA-8	Vascojet 1000 (H-11) (Annealed)	VI-19
VIA-9	Rene '41 (Solution Treated)	VI-20

LIST OF DESIGN TABLES (Contd.)

<u>Table</u>		<u>Page</u>
VIA-10	Inconel X (C.R. Annealed)	VI-21
VIA-11	Hastelloy X (Solution Treated)	VI-22
VIA-12	L-605 (Solution Treated)	VI-23
VIA-13	J-1570 (Solution Treated)	VI-24
VIA-14	Columbium (10 Mo-10 Ti)	VI-25
VIA-15	Molybdenum (.5% Ti) (Hot Rolled, Stress Relieved).....	VI-26
DROP HAMMER BEAD LIMITS		
VIB-1	2024-0 Aluminum	VI-44
VIB-2	17-7 PH Stainless Steel (Condition "A")	VI-45
VIB-3	PH 15-7 Mo Stainless Steel (Condition "A")	VI-46
VIB-4	AM-350 Stainless Steel (Annealed)	VI-47
VIB-5	A-286 Stainless Steel (Solution Treated Condition)...	VI-48
VIB-6	USS-12-MoV Stainless Steel (Annealed)	VI-49
VIB-7	Vascojet 1000 (H-11) (Annealed)	VI-50
VIB-8	Rene'41 (Solution Treated)	VI-51
VIB-9	Inconel X (C.R. Annealed)	VI-52
VIB-10	Hastelloy X (Solution Treated)	VI-53
VIB-11	L-605 (Solution Treated)	VI-54
VIB-12	J-1570 (Solution Treated)	VI-55

LIST OF SYMBOLS

Because of the large number of terms used, the following list of symbols is supplied for easy reference:

P = load on tensile specimen

l_o = original gage length

l_f = final gage length

A_o = original cross-sectional area

A_f = final cross-sectional area

A_i = instantaneous cross-sectional area

E = Young's Modulus of elasticity *

S_u = tensile stress $\left(\frac{P}{A_o}\right)$ at ultimate load

S_{TY} = tensile stress $\left(\frac{P}{A_o}\right)$ at yield point

S_{CY} = compressive stress $\left(\frac{P}{A_o}\right)$ at yield point

σ = true stress $\left(\frac{P}{A_i}\right)$; subscripts l , w and t

represent the longitudinal, width and thickness

directions

σ_e = effective stress from Energy of Distortion Theory

$\epsilon =$ conventional strain $\left(\frac{l_f - l_o}{l_o} \right)$

$\epsilon_{2.0} =$ conventional strain for 2 inch gage length

$\epsilon_{.02} =$ conventional strain for .02 inch gage length

$\bar{\epsilon} =$ natural strain $\left(\ln \frac{l_f}{l_o} \right)$; subscripts l , w and t
represent the longitudinal, width and thickness
directions

$\bar{\epsilon}_e =$ effective strain from Energy of Distortion Theory

$[\epsilon_{.5}]_{\text{CORRECTED}} =$ 0.5 inch gage length elongation corrected to a
condition of plane strain .

$[\bar{\epsilon}_{.25}]_{\text{CORRECTED}} =$ 0.25 inch gage length elongation corrected to a
condition of plane strain

NOTE: Additional symbols are described throughout the
text for continuity.

* Designates the tensile modulus of elasticity when used
in conjunction with the tensile yield strength and the
compressive modulus of elasticity when used in conjunction
with the compressive yield strength.

INTRODUCTION

This second volume is intended to serve as a handbook covering the quantitative results generated in the program. These results are presented in a number of forms: (1) composite graphs representing the formability limits of the materials covered in the program, (2) predictability equations representing the formability limits for any material, based on the properties of the material, and (3) design tables in ready reference form for determining the formability limits of the materials tested on the program.

Composite graphs and design tables are presented for approximately nineteen materials for each of the twelve forming processes evaluated on the program. Limits are given for specific shapes of parts for each of the twelve forming processes. Some of the processes include only one part geometry while others include many. It should be emphasized that, although most of the important shapes of parts are included in the program, the limits presented are restricted to these shapes.

The predictability equations are given for use in developing formability limits for any material, based on the mechanical properties of the material. It should be realized that these equations are only as good as the properties used in them. This restricts the equation, when applied to materials with a considerable spread in properties, to those sheets from which the properties were taken.

Manuscript released by authors August 1961 for publication as an ASD Technical Report.

In general, optimum forming conditions were used with regard to lubrication, pressure, and other operating variables. These, and the other limitations and considerations associated with each forming process, are discussed in each section. It is advised that each section should be thoroughly read before application of the graphs, equations, and tables.

SECTION I
BENDING
A. BRAKE FORMING
B. JOGGLING

BRAKE FORMING

Description of Process

Brake forming is the bending of sheet metal by a press brake so that the metal on the inside of the bend is compressed while the metal on the outside of the bend is stretched. This process is invaluable to industry due to the infinite variety of shapes that, with the proper dies, may be obtained. Although a Verson 60 ton Press Brake with a three (3) inch ram stroke and workpiece specimens measuring two by three (2 x 3) inches were used for this program, the resultant data is applicable to any standard press brake and for any size material.

By referring to Figure IA-1 the set-up for a brake forming operation is apparent.

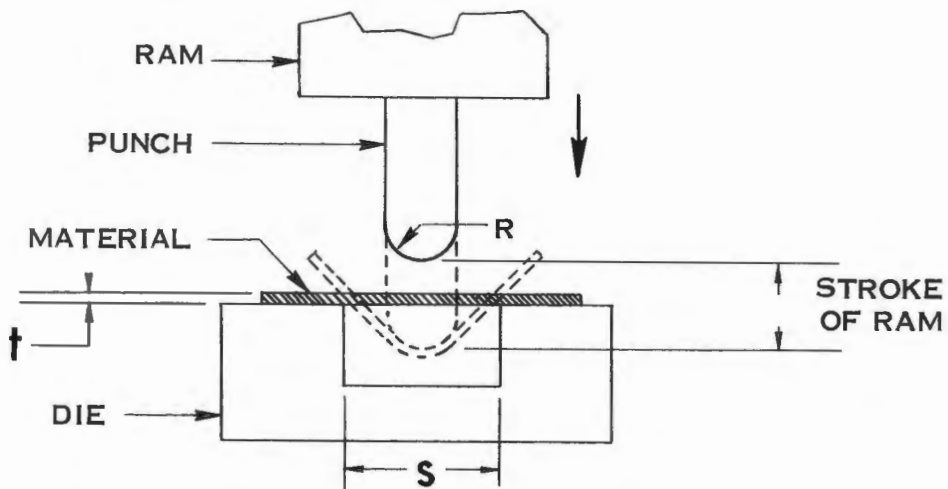

TYPICAL BRAKE FORMING SETUP
FIG. I A-1

During the forming process the ram forces the punch and workpiece into the die cavity. In all air bends the workpiece is supported only at its outer edges so that the length of stroke of the ram determines the part angle (α). The metal is so bent that the inside radius of the workpiece is the same as the punch radius. Other means such as hand working and stress relief dies are used when necessary to finish the part.

Ram pressure must be sufficient as an increase in either sheet thickness or tensile strength of the workpiece requires an increase in pressure for a successful bend. The adjustment of the ram stroke alters the part angle while the speed of the ram (number of strokes per minute) to certain materials such as molybdenum is critical. Molybdenum should be formed at as slow a rate as possible due to the strain rate effect on this material.

The die channel width (S) is determined by the material thickness (t) and the punch radius (R), (See Figure IA-2), from which the equation $S = 2.488 R + 2 t$ is derived. This die channel width (S) is not the optimum opening for each specific material, but rather is a median of two commonly accepted die opening values.

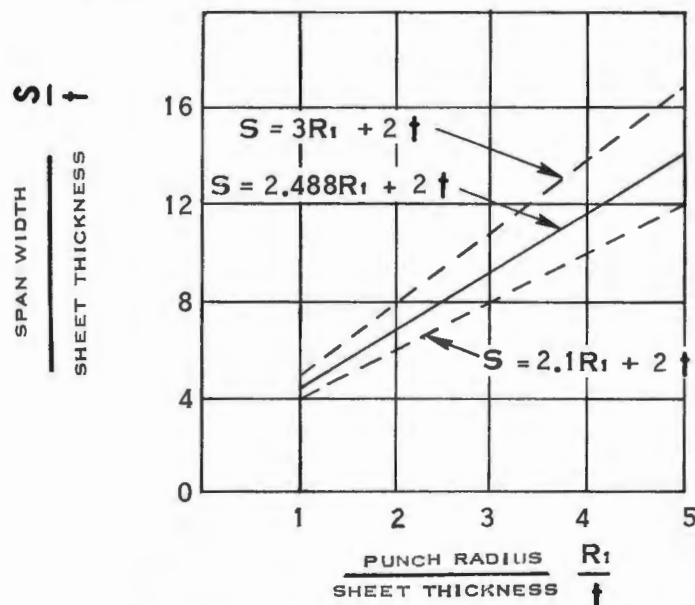

GRAPHICAL DIE OPENING VALUES
FIG. 1 A-2

Definition of Part Shape
and Geometric Variables

The geometric variables for brake forming are the punch radius (R), the material thickness (t), and the part angle (α). By varying these parameters good parts and failures can be obtained. The failure of a bent part occurs when the tension in the outer fibers of the part becomes too great; i.e., when the bend becomes too sharp (small radius to material thickness for a given part angle). (See Figure IA-3).

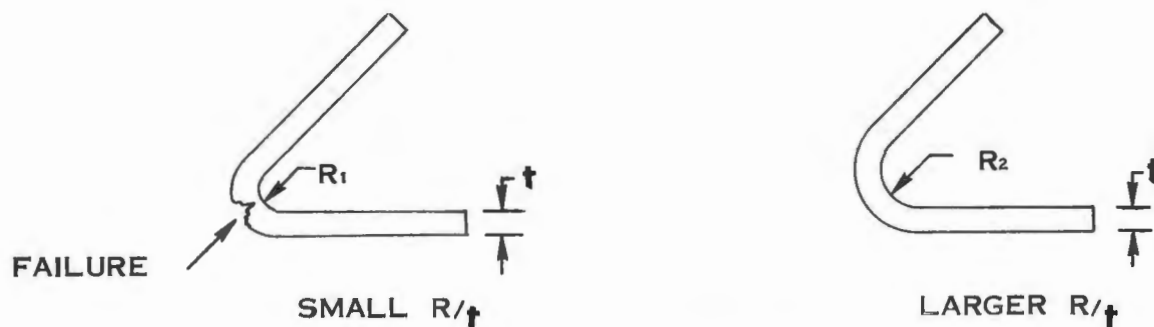

EFFECT OF VARYING R/t VALUES
FIG. IA-3

Therefore, a relationship exists between the tension in the outer fibers and the R/t value of a workpiece. As the R/t value increases the tension decreases and up to a point, as the part angle increases, the R/t value must also be increased to prevent the tension from becoming too great and resulting in failure of the part. (See Figure IA-4).

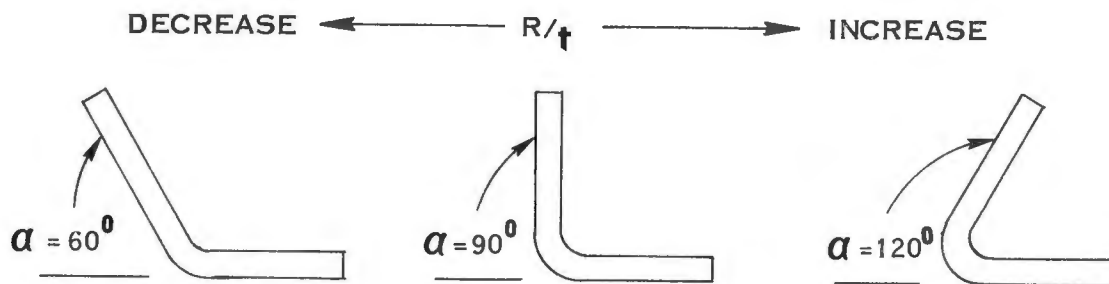

EFFECT OF PART ANGLE ON R/t VALUE
FIG. 1 A-4

If, after being formed the metal retains some of its original elasticity, springback may be present. In case this does occur it will be necessary to lengthen the stroke of the ram and thus "overbend" the workpiece to compensate for this condition.

The direction of rolling of the metal has an appreciable effect on the ease of forming. (See Figure IA-5). If the workpiece is bent perpendicular to the direction of rolling (longitudinal) it can, with few exceptions be bent with a smaller R/t value than if bent parallel to the direction of rolling (transverse).

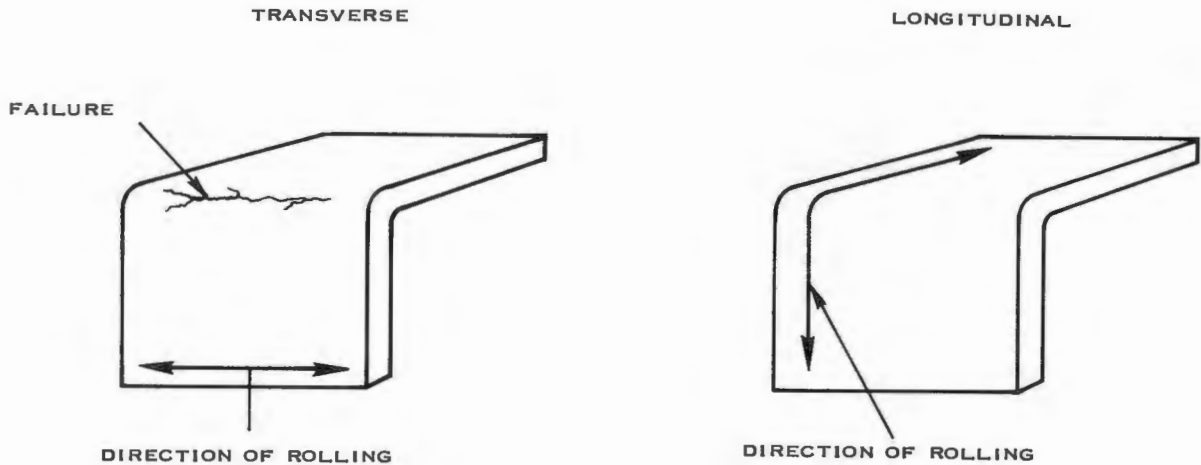

EFFECT OF DIRECTION OF ROLL ON BENDING
FIG. 1 A-5

Predictability Equations

The basic equation to correlate natural strain to brake forming parameters:

$$\bar{\epsilon} = \ln \sqrt{1 + t/R}$$

Equation I

The formability index used for this process:

$$\bar{\epsilon} = \bar{\epsilon}_{.25(\text{corrected})}$$

The equation to find the value of R/t where $\alpha > \phi$.

$$R/t_{[\alpha > \phi]} = \frac{1}{e^{2\bar{\epsilon}_{.25(\text{CORR.})}} - 1}$$

Equation II

The equation to find the value of R/t where $\alpha < \phi$.

$$R/t = 1/2 [R/t_{[\alpha > \phi]}] [1 + \sin(\theta - 90^\circ)]$$

Equation III

The equation to find ϕ , that part angle where the curve reaches a maximum:

$$\phi = \frac{11.4 - R/t}{.0845} [\alpha > \phi]$$

Equation IV

The equation to find the part angle - (α):

$$\alpha = \theta \frac{\phi}{180^\circ}$$

Equation V

The basic equation to find any R/t value when $\bar{\epsilon}_{.25(\text{corr})}$ is known and $\alpha < \phi$:

Equation VI

$$R/t = 1/2 \left[e^{2\bar{\epsilon}_{.25(\text{CORR.})}} - 1 \right]^{-1} \left[1 + \text{SIN} \left(\frac{15.21\alpha}{11.4 - (e^{2\bar{\epsilon}_{.25(\text{CORR.})}} - 1)^{-1}} - 90^\circ \right) \right]$$

Where:

R = Punch radius or inside bend radius

t = Material thickness

e = Natural logarithmic base

α = Part angle

ϕ = That part angle where the curve reaches a maximum

(Any further bending will not increase the strain.)

θ = Any selected angle from 0° to 180° .

To find the value for $\bar{\epsilon}_{.25(\text{corr})}$ a tension test must be made on a specimen gridded with one-quarter inch squares. After the specimen is pulled one grid at the point of failure is measured to determine the change in length (ΔL) and the change in width (ΔW). The measurements are taken as shown in Figure IA-6.

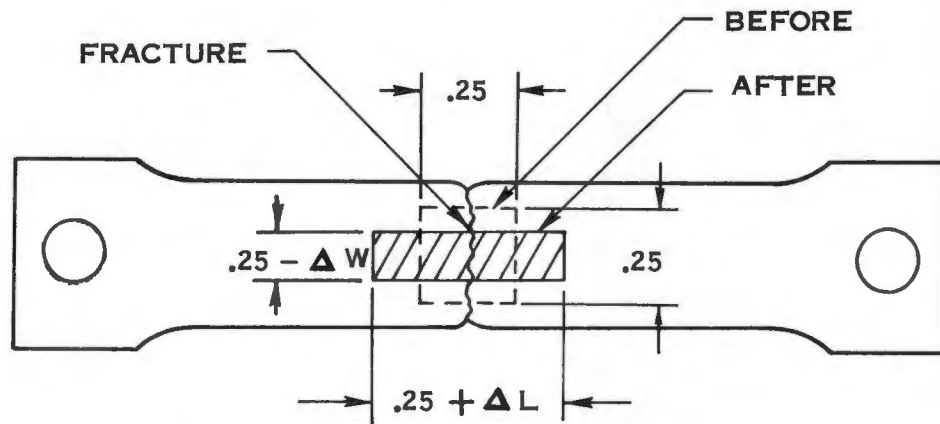

TYPICAL GRIDDED TENSION SPECIMEN
FIG. I A-6

The calculations to find the corrected value of the natural strain are as follows:

$$(\epsilon_L)_{.25} = \frac{\Delta L}{0.25} \quad (\bar{\epsilon}_L)_{.25} = \ln [1 + (\epsilon_L)_{.25}]$$

$$(\epsilon_w)_{.25} = \frac{\Delta W}{0.25} \quad (\bar{\epsilon}_w)_{.25} = \ln [1 + (\epsilon_w)_{.25}]$$

Thus the equation for finding $\bar{\epsilon}_{.25}(\text{corr})$ is:

$$\bar{\epsilon}_{.25}(\text{corr}) = (\bar{\epsilon}_L)_{.25} - \frac{(\bar{\epsilon}_w)_{.25}^2}{(\bar{\epsilon}_L)_{.25}} \quad \text{Equation VII}$$

By pulling a tension test specimen and measuring the strain, any R/t value can be found by using either Equation II or VI for any selected part angle. This data can then be used to construct a graph showing the splitting limits for any part angle for a particular material.

PROBLEM: Find the R/t value splitting limits for all part angles of a material and plot on graph.

GIVEN: $\bar{\epsilon}_{.25(CORR)} = 0.4$ (From tension specimen)

Step I. - Solve for R/t where $\alpha > \phi$.

Equation II

$$\begin{aligned} R/t \text{ Max.} &= \frac{1}{e^{2\bar{\epsilon}_{.25(CORR)}} - 1} \\ &= \frac{1}{e^{2 \times .4} - 1} \\ &= \frac{1}{e^{.8} - 1} \\ &= \frac{1}{2.225 - 1} \\ R/t \text{ Max.} &= \underline{\underline{0.815}} \end{aligned}$$

Step II. - Solve for ϕ :

Equation IV

$$\begin{aligned} \phi &= \frac{11.4 - R/t \text{ Max.}}{.0845} \\ &= \frac{11.4 - 0.815}{.0895} \\ \phi &= \underline{\underline{125^\circ}} \end{aligned}$$

Step III. - Solve for R/t where $\alpha < \phi$.

When $\alpha = 30^\circ$

Equation VI

$$\begin{aligned} R/t &= 1/2 \left[e^{2\bar{\epsilon}_{.25(CORR)}} - 1 \right]^{-1} \left[1 + \text{SIN} \left(\frac{15.21\alpha}{11.4 - (e^{2\bar{\epsilon}_{.25(CORR)}} - 1)^{-1}} - 90^\circ \right) \right] \\ &= 1/2 \left[e^{2 \times .4} - 1 \right]^{-1} \left[1 + \text{SIN} \left(\frac{15.21 \times 30}{11.4 - (e^{2 \times .4} - 1)^{-1}} - 90^\circ \right) \right] \end{aligned}$$

$$= 1/2 [.815] [1 + \text{SIN } 41.6 - 90]$$

$$= 1/2 [.815] [1 - .748]$$

$$R/t = \underline{\underline{0.1025}}$$

Step IV. Repeat Step III for several values of α less than ϕ

Step V. Construct a graph with R/t values on the ordinate and part angle α on the abscissa.

Step VI. Plot the calculated values of R/t^* on the graph and connect with a smooth curve. (See Figure IA-7).

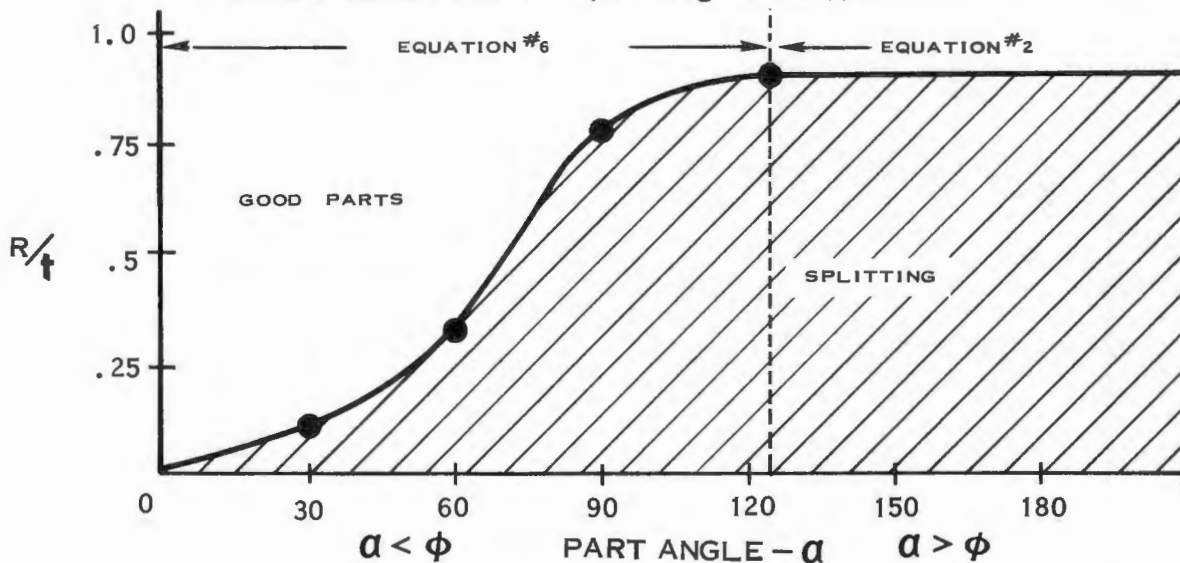

**SPLITTING LIMIT CURVE FOR BRAKE FORMING
FIG. IA-7**

*The R/t value when $\alpha = \phi$ is a maximum so the slope of the curve becomes zero.

With this graph it is possible to select an R/t value for any angle - (α). Then by knowing the material thickness - (t) the correct punch radius can be selected.

Composite Graphs

For a composite graph of brake forming limits for those materials investigated in this program, see Graph IA-1.

It might prove possible in some instances to extend the splitting limits for a given material by better lubrication of the die, reducing the surface roughness of the material and the die, reducing the strain rate as in the case of Molybdenum and All Beta Titanium, or by applying heat. Those materials whose splitting limits were extended by the application of heat appear in Graph IA-2. The correlation between $\bar{\epsilon}_{25 \text{ (CORR)}}$ and the maximum R/t values for the materials in this program appear as Graph IA-3.

In order to correlate Molybdenum it was necessary to reduce the strain rate effect on the material to that of the tension tests. This resulted in a lower R/t value than would be obtained by operating the brake press at normal speeds. This reduced strain rate effect is recommended in forming this material.

The Columbium (10-10) material used in this program varied greatly in its properties from sheet to sheet. The material as received from the mill was both hot and cold rolled. Lamination proved a problem that resulted in poor and varied R/t values. Correlation could be achieved only by taking tension and brake forming specimens from the same sheet stock. Thus the correlation and splitting limits of this material did not agree from sheet to sheet. Therefore, rather than publish misleading data from obviously erratic results Columbium (10-10) is deleted from all graphs and design tables of Section IA, Brake Forming.

Three materials failed to correlate properly. Of these 2024-O Aluminum deviated from the theoretical curve due to the dig in effect of the punch. This caused a reduction of the tension in the outer fibers of this soft material. The two hexagonal close packed materials, 6-4 Titanium and HM21XA-T8, also deviated from the correlation curve. This was expected as hexagonal close packed materials cannot achieve a maximum slip plane in a bending operation as body centered cubic and face centered cubic materials do. Therefore, it is expected that any hexagonal close packed material will fall on some other theoretical curve with a possible position such as that shown in Graph IA-3.

It was discovered that the elongation of a material increases as its thickness (t) increases. Thus it proved necessary to recommend a particular gage for each type of alloy in order to correlate properly. In any theoretical attempt at predicting the brake forming splitting limits of an alloy the gages recommended in Fig. IA-8 should be used.

FIGURE IA-8
 RECOMMENDED TENSILE SPECIMEN
 GAGES FOR BRAKE FORMING CORRELATION

Structure	Material Type	Recommended Tensile Specimen Gage	Materials on this Program
B.C.C.	Titanium Refractories	.010 .020 .020	All Beta Molybdenum (.5%Ti) Columbium (10-10)
F.C.C.	Nickel Base Cobalt Base Steels Aluminum	.020 .020 .020 .032 .032 .040 .040 .040 .040 .040 .063	Inconel X Rene'41 Hastelloy X J-1570 L-605 A-286 PH 15-7 Mo 17-7 PH AM-350 USS 12 MoV Vascojet 1000 2024-0
H.C.P.	Titanium Magnesium	.071	6-4 Titanium HM21XA-T8

GRAPH IA-1

COMPOSITE ROOM TEMPERATURE
SPLITTING LIMITS FOR BRAKE FORMING

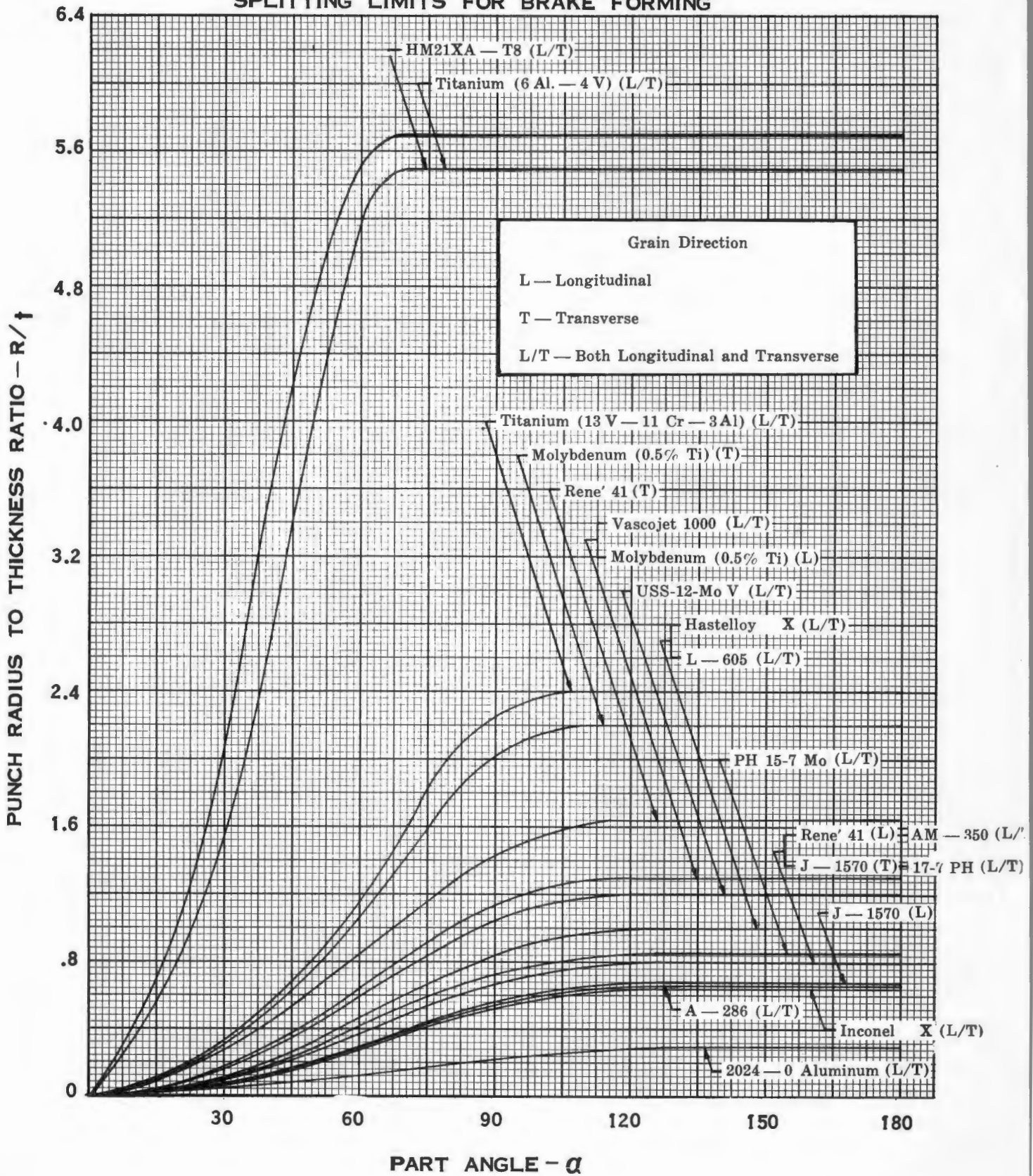

GRAPH I A -2
 BRAKE FORMING SPLITTING LIMITS
 AT ELEVATED TEMPERATURES

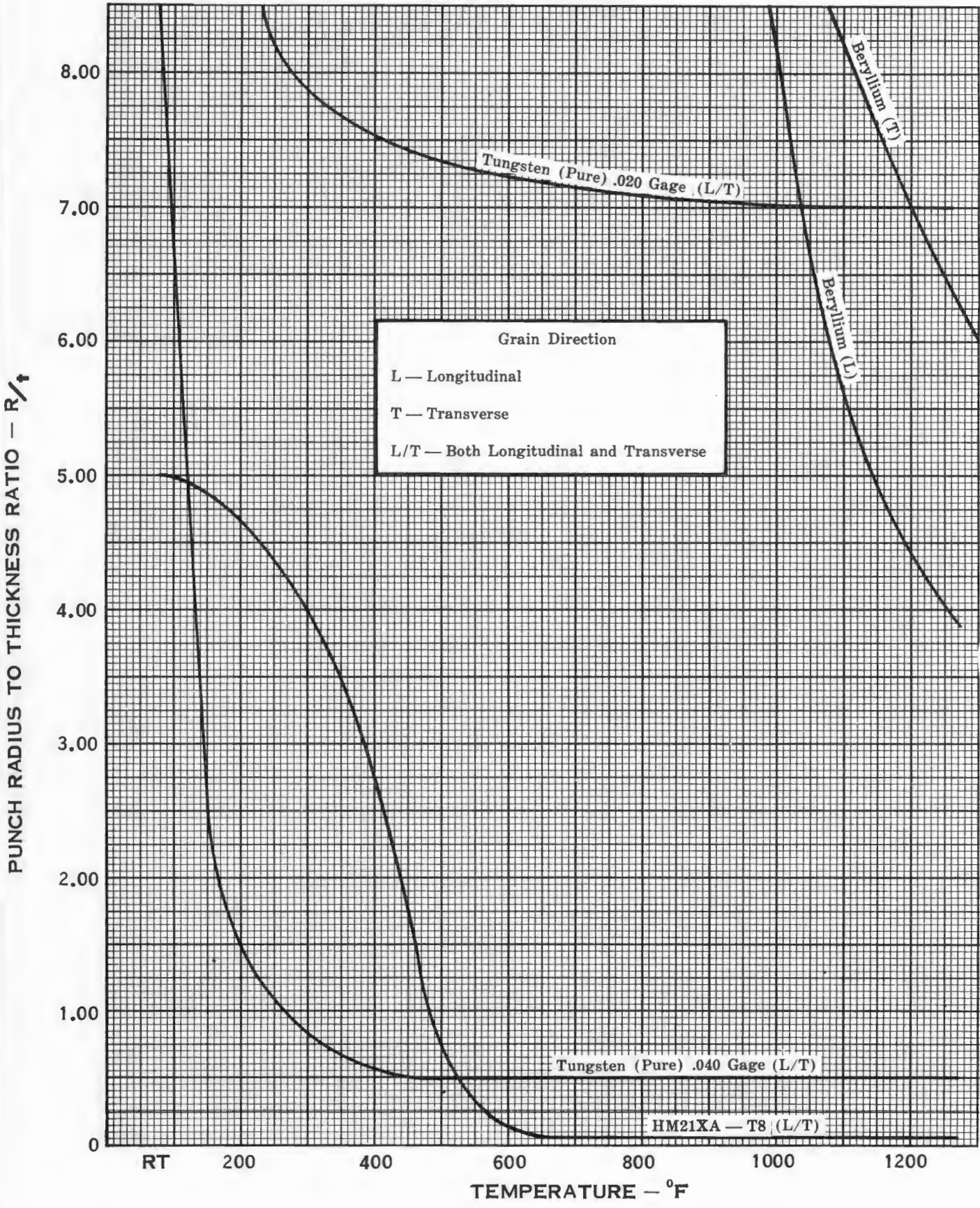

SPLITTING CORRELATION CURVES FOR BRAKE FORMING AT ROOM TEMPERATURE

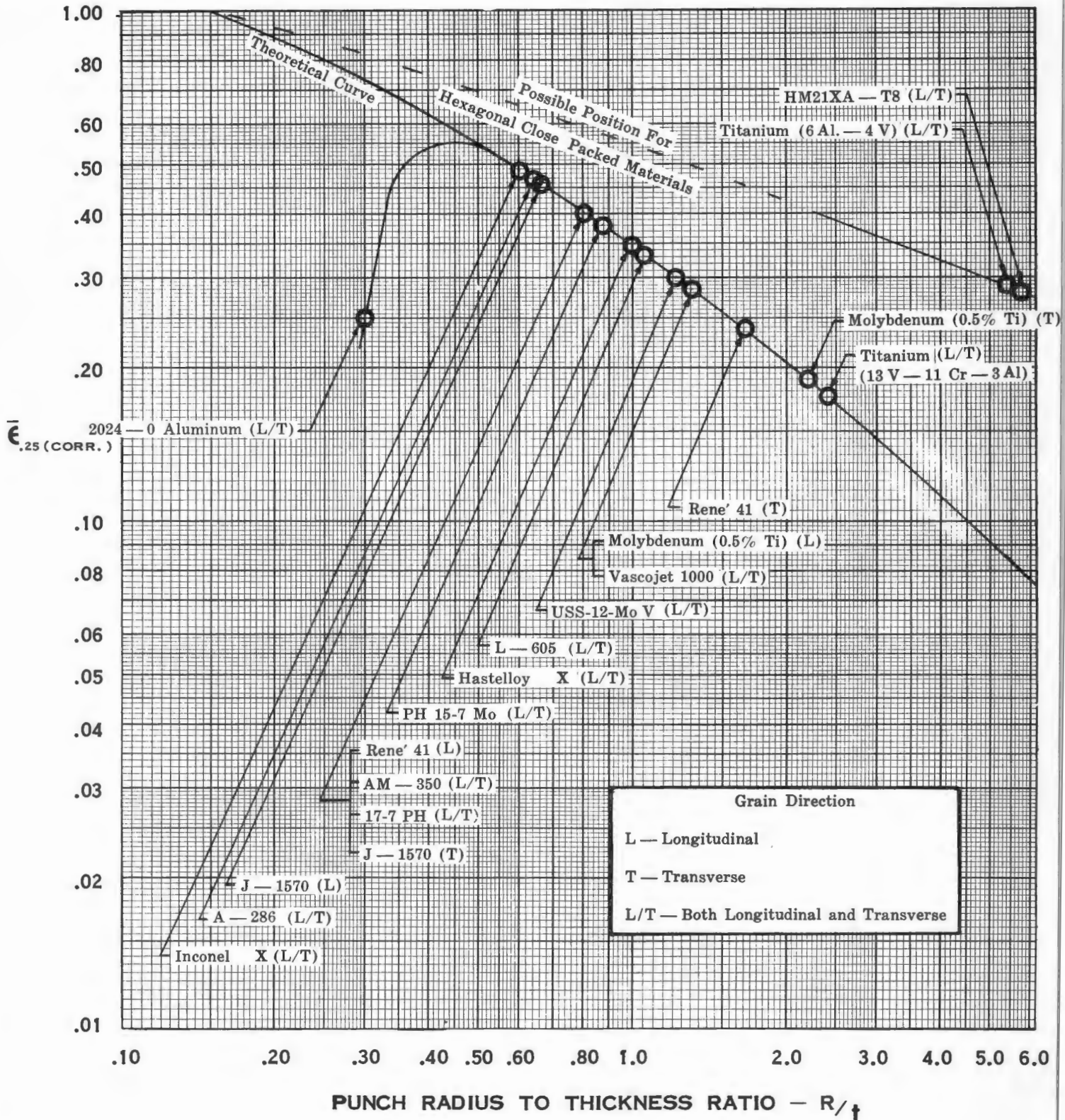

Design Tables

It should be noted that the punch radii recommended in these design tables are conservative so it may, in certain instances, prove possible to exceed these limits.

To use the design tables:

- (1) Select the correct table for the material.
- (2) Select a vertical column for the part angle - (α).
- (3) Read down the vertical column until crossing a horizontal column of the desired value of (t).
- (4) Where the two columns intersect read the recommended punch radius - (R).

To use the Elevated Temperature Tables, note that $\alpha = 90^\circ$ and has been replaced as the vertical column by a temperature in $^\circ\text{F}$.

Due to the erratic behavior of Columbium (10-10) this material is deleted from the design table section as well as those materials whose splitting limits increased at elevated temperatures.

TABLE IA-1
 MINIMUM BEND RADIUS LIMITS
 HM21XA-T8 MAGNESIUM THORIUM
 LONGITUDINAL AND TRANSVERSE
 GRAIN DIRECTION

$\alpha = 60^\circ$		$\alpha = 90^\circ$		$\alpha = 120^\circ$	
Gage (t)	Radius (R)	Gage (t)	Radius (R)	Gage (t)	Radius (R)
.016	.093	.016	.093	.016	.093
.020	.109	.020	.125	.020	.125
.025	.140	.025	.156	.025	.156
.032	.187	.032	.187	.032	.187
.040	.218	.040	.234	.040	.234
.050	.281	.050	.312	.050	.312
.063	.343	.063	.375	.063	.375
.071	.406	.071	.406	.071	.406
.080	.437	.080	.468	.080	.468
.090	.500	.090	.562	.090	.562
.100	.562	.100	.625	.100	.625
.125	.687	.125	.750	.125	.750
.187	1.125	.187	1.125	.187	1.125

TABLE IA-2
 MINIMUM BEND RADIUS LIMITS
 2024-O ALUMINUM
 LONGITUDINAL AND TRANSVERSE
 GRAIN DIRECTION

$\alpha = 60^\circ$		$\alpha = 90^\circ$		$\alpha = 120^\circ$	
Gage (t)	Radius (R)	Gage (t)	Radius (R)	Gage (t)	Radius (R)
.016	.015	.016	.015	.016	.015
.020	.015	.020	.015	.020	.015
.025	.015	.025	.015	.025	.015
.032	.015	.032	.015	.032	.015
.040	.015	.040	.015	.040	.015
.050	.015	.050	.015	.050	.015
.063	.015	.063	.015	.063	.031
.071	.015	.071	.015	.071	.031
.080	.015	.080	.031	.080	.031
.090	.015	.090	.031	.090	.031
.100	.015	.100	.031	.100	.031
.125	.015	.125	.031	.125	.046
.187	.031	.187	.046	.187	.062

TABLE IA-3
 MINIMUM BEND RADIUS LIMITS
 17-7 PH (CONDITION "A", MILL ANNEALED)
 LONGITUDINAL AND TRANSVERSE
 GRAIN DIRECTION

$\alpha = 60^\circ$		$\alpha = 90^\circ$		$\alpha = 120^\circ$	
Gage (t)	Radius (R)	Gage (t)	Radius (R)	Gage (t)	Radius (R)
.016	.015	.016	.015	.016	.015
.020	.015	.020	.015	.020	.031
.025	.015	.025	.031	.025	.031
.032	.015	.032	.031	.032	.031
.040	.015	.040	.031	.040	.046
.050	.031	.050	.046	.050	.046
.063	.031	.063	.046	.063	.062
.071	.031	.071	.062	.071	.062
.080	.031	.080	.062	.080	.078
.090	.046	.090	.062	.090	.078
.100	.046	.100	.078	.100	.093
.125	.046	.125	.093	.125	.109
.187	.078	.187	.125	.187	.156

TABLE IA-4
 MINIMUM BEND RADIUS LIMITS
 PH 15-7 Mo (CONDITION "A", MILL ANNEALED)
 LONGITUDINAL AND TRANSVERSE
 GRAIN DIRECTION

$\alpha = 60^\circ$		$\alpha = 90^\circ$		$\alpha = 120^\circ$	
Gage (t)	Radius (R)	Gage (t)	Radius (R)	Gage (t)	Radius (R)
.016	.015	.016	.015	.016	.015
.020	.015	.020	.015	.020	.031
.025	.015	.025	.031	.025	.031
.032	.015	.032	.031	.032	.031
.040	.031	.040	.031	.040	.046
.050	.031	.050	.046	.050	.046
.063	.031	.063	.046	.063	.062
.071	.031	.071	.062	.071	.062
.080	.046	.080	.062	.080	.078
.090	.046	.090	.078	.090	.078
.100	.046	.100	.078	.100	.093
.125	.062	.125	.093	.125	.109
.187	.078	.187	.140	.187	.171

TABLE IA-5
 MINIMUM BEND RADIUS LIMITS
 AM-350 (ANNEALED)
 LONGITUDINAL AND TRANSVERSE
 GRAIN DIRECTION

$\alpha = 60^\circ$		$\alpha = 90^\circ$		$\alpha = 120^\circ$	
Gage (t)	Radius (R)	Gage (t)	Radius (R)	Gage (t)	Radius (R)
.016	.015	.016	.015	.016	.015
.020	.015	.020	.015	.020	.031
.025	.015	.025	.031	.025	.031
.032	.015	.032	.031	.032	.031
.040	.015	.040	.031	.040	.046
.050	.031	.050	.046	.050	.046
.063	.031	.063	.046	.063	.062
.071	.031	.071	.062	.071	.062
.080	.031	.080	.062	.080	.078
.090	.046	.090	.062	.090	.078
.100	.046	.100	.078	.100	.093
.125	.046	.125	.093	.125	.109
.187	.078	.187	.125	.187	.156

TABLE IA-6
 MINIMUM BEND RADIUS LIMITS
 A-286 (SOLUTION TREATED CONDITION)
 LONGITUDINAL AND TRANSVERSE
 GRAIN DIRECTION

$\alpha = 60^\circ$		$\alpha = 90^\circ$		$\alpha = 120^\circ$	
Gage (t)	Radius (R)	Gage (t)	Radius (R)	Gage (t)	Radius (R)
.016	.015	.016	.015	.016	.015
.020	.015	.020	.015	.020	.015
.025	.015	.025	.015	.025	.031
.032	.015	.032	.031	.032	.031
.040	.015	.040	.031	.040	.031
.050	.015	.050	.031	.050	.046
.063	.031	.063	.046	.063	.046
.071	.031	.071	.046	.071	.046
.080	.031	.080	.046	.080	.062
.090	.031	.090	.062	.090	.062
.100	.031	.100	.062	.100	.078
.125	.046	.125	.078	.125	.093
.187	.062	.187	.109	.187	.125

TABLE IA-7
 MINIMUM BEND RADIUS LIMITS
 USS-12-M \oplus V (ANNEALED)
 LONGITUDINAL AND TRANSVERSE
 GRAIN DIRECTION

$\alpha = 60^\circ$		$\alpha = 90^\circ$		$\alpha = 120^\circ$	
Gage (t)	Radius (R)	Gage (t)	Radius (R)	Gage (t)	Radius (R)
.016	.015	.016	.031	.016	.031
.020	.015	.020	.031	.020	.031
.025	.015	.025	.031	.025	.031
.032	.031	.032	.046	.032	.046
.040	.031	.040	.046	.040	.062
.050	.031	.050	.062	.050	.062
.063	.046	.063	.078	.063	.078
.071	.046	.071	.078	.071	.093
.080	.046	.080	.093	.080	.109
.090	.062	.090	.109	.090	.109
.100	.062	.100	.109	.100	.125
.125	.078	.125	.140	.125	.156
.187	.109	.187	.203	.187	.234

TABLE IA-8
 MINIMUM BEND RADIUS LIMITS
 TITANIUM (6Al-4V) (MILL ANNEALED)
 LONGITUDINAL AND TRANSVERSE
 GRAIN DIRECTION

$\alpha = 60^\circ$		$\alpha = 90^\circ$		$\alpha = 120^\circ$	
Gage (t)	Radius (R)	Gage (t)	Radius (R)	Gage (t)	Radius (R)
.016	.093	.016	.109	.016	.109
.020	.125	.020	.125	.020	.125
.025	.156	.025	.156	.025	.156
.032	.187	.032	.187	.032	.187
.040	.234	.040	.234	.040	.234
.050	.312	.050	.312	.050	.312
.063	.375	.063	.375	.063	.375
.071	.406	.071	.437	.071	.437
.080	.468	.080	.468	.080	.468
.090	.562	.090	.562	.090	.562
.100	.625	.100	.625	.100	.625
.125	.750	.125	.750	.125	.750
.187	1.125	.187	1.125	.187	1.125

TABLE IA-9
 MINIMUM BEND RADIUS LIMITS
 TITANIUM (13V-11Cr-3Al) (SOLUTION TREATED)
 LONGITUDINAL AND TRANSVERSE
 GRAIN DIRECTION

$\alpha = 60^\circ$		$\alpha = 90^\circ$		$\alpha = 120^\circ$	
Gage (t)	Radius (R)	Gage (t)	Radius (R)	Gage (t)	Radius (R)
.016	.031	.016	.046	.016	.046
.020	.031	.020	.046	.020	.062
.025	.031	.025	.062	.025	.062
.032	.046	.032	.078	.032	.078
.040	.062	.040	.093	.040	.109
.050	.062	.050	.125	.050	.125
.063	.078	.063	.140	.063	.156
.071	.093	.071	.171	.071	.171
.080	.093	.080	.187	.080	.203
.090	.109	.090	.203	.090	.218
.100	.125	.100	.234	.100	.250
.125	.156	.125	.281	.125	.312
.187	.218	.187	.437	.187	.468

TABLE IA-10
 MINIMUM BEND RADIUS LIMITS
 VASCOJET 1000 (H-11) (ANNEALED)
 LONGITUDINAL AND TRANSVERSE
 GRAIN DIRECTION

$\alpha = 60^\circ$		$\alpha = 90^\circ$		$\alpha = 120^\circ$	
Gage (t)	Radius (R)	Gage (t)	Radius (R)	Gage (t)	Radius (R)
.016	.015	.016	.031	.016	.031
.020	.015	.020	.031	.020	.031
.025	.031	.025	.031	.025	.046
.032	.031	.032	.046	.032	.046
.040	.031	.040	.046	.040	.062
.050	.046	.050	.062	.050	.078
.063	.046	.063	.078	.063	.093
.071	.062	.071	.093	.071	.093
.080	.062	.080	.093	.080	.109
.090	.062	.090	.109	.090	.125
.100	.078	.100	.125	.100	.140
.125	.093	.125	.140	.125	.171
.187	.125	.187	.218	.187	.250

TABLE IA-11
 MINIMUM BEND RADIUS LIMITS
 RENE '41 (SOLUTION TREATED)
 LONGITUDINAL GRAIN DIRECTION

$\alpha = 60^\circ$		$\alpha = 90^\circ$		$\alpha = 120^\circ$	
Gage (t)	Radius (R)	Gage (t)	Radius (R)	Gage (t)	Radius (R)
.016	.015	.016	.015	.016	.015
.020	.015	.020	.015	.020	.031
.025	.015	.025	.031	.025	.031
.032	.015	.032	.031	.032	.031
.040	.015	.040	.040	.040	.046
.050	.031	.050	.046	.050	.046
.063	.031	.063	.046	.063	.062
.071	.031	.071	.062	.071	.062
.080	.031	.080	.062	.080	.078
.090	.046	.090	.062	.090	.078
.100	.046	.100	.078	.100	.093
.125	.046	.125	.093	.125	.109
.187	.078	.187	.125	.187	.156

TABLE IA-12
 MINIMUM BEND RADIUS LIMITS
 RENE '41 (SOLUTION TREATED)
 TRANSVERSE GRAIN DIRECTION

$\alpha = 60^\circ$		$\alpha = 90^\circ$		$\alpha = 120^\circ$	
Gage (t)	Radius (R)	Gage (t)	Radius (R)	Gage (t)	Radius (R)
.016	.015	.016	.031	.016	.031
.020	.031	.020	.031	.020	.046
.025	.031	.025	.046	.025	.046
.032	.031	.032	.046	.032	.062
.040	.046	.040	.062	.040	.078
.050	.046	.050	.078	.050	.093
.063	.062	.063	.093	.063	.109
.071	.062	.071	.109	.071	.125
.080	.078	.080	.125	.080	.140
.090	.078	.090	.140	.090	.156
.100	.093	.100	.156	.100	.171
.125	.109	.125	.187	.125	.218
.187	.171	.187	.281	.187	.312

TABLE IA-13
 MINIMUM BEND RADIUS LIMITS
 INCONEL X (C.R. ANNEALED)
 LONGITUDINAL AND TRANSVERSE
 GRAIN DIRECTION

$\alpha = 60^\circ$		$\alpha = 90^\circ$		$\alpha = 120^\circ$	
Gage (t)	Radius (R)	Gage (t)	Radius (R)	Gage (t)	Radius (R)
.016	.015	.016	.015	.016	.015
.020	.015	.020	.015	.020	.015
.025	.015	.025	.015	.025	.015
.032	.015	.032	.031	.032	.031
.040	.015	.040	.031	.040	.031
.050	.015	.050	.031	.050	.031
.063	.031	.063	.046	.063	.046
.071	.031	.071	.046	.071	.046
.080	.031	.080	.046	.080	.062
.090	.031	.090	.046	.090	.062
.100	.031	.100	.062	.100	.062
.125	.046	.125	.078	.125	.078
.187	.062	.187	.093	.187	.125

TABLE IA-14
 MINIMUM BEND RADIUS LIMITS
 HASTELLOY X (SOLUTION TREATED)
 LONGITUDINAL AND TRANSVERSE
 GRAIN DIRECTION

$\alpha = 60^\circ$		$\alpha = 90^\circ$		$\alpha = 120^\circ$	
Gage (t)	Radius (R)	Gage (t)	Radius (R)	Gage (t)	Radius (R)
.016	.015	.016	.015	.016	.031
.020	.015	.020	.031	.020	.031
.025	.015	.025	.031	.025	.031
.032	.031	.032	.031	.032	.046
.040	.031	.040	.046	.040	.046
.050	.031	.050	.046	.050	.062
.063	.031	.063	.062	.063	.078
.071	.046	.071	.062	.071	.078
.080	.046	.080	.078	.080	.093
.090	.046	.090	.078	.090	.093
.100	.062	.100	.093	.100	.109
.125	.062	.125	.109	.125	.125
.187	.093	.187	.156	.187	.187

TABLE IA-15
 MINIMUM BEND RADIUS LIMITS
 L-605 (SOLUTION TREATED)
 LONGITUDINAL AND TRANSVERSE
 GRAIN DIRECTION

$\alpha = 60^\circ$		$\alpha = 90^\circ$		$\alpha = 120^\circ$	
Gage (t)	Radius (R)	Gage (t)	Radius (R)	Gage (t)	Radius (R)
.016	.015	.016	.015	.016	.031
.020	.015	.020	.031	.020	.031
.025	.015	.025	.031	.025	.031
.032	.031	.032	.031	.032	.046
.040	.031	.040	.046	.040	.046
.050	.031	.050	.046	.050	.062
.063	.031	.063	.062	.063	.078
.071	.046	.071	.062	.071	.078
.080	.046	.080	.078	.080	.093
.090	.046	.090	.078	.090	.093
.100	.062	.100	.093	.100	.109
.125	.062	.125	.109	.125	.125
.187	.093	.187	.156	.187	.187

TABLE IA-16
 MINIMUM BEND RADIUS LIMITS
 J-1570 (SOLUTION TREATED)
 LONGITUDINAL GRAIN DIRECTION

$\alpha = 60^\circ$		$\alpha = 90^\circ$		$\alpha = 120^\circ$	
Gage (t)	Radius (R)	Gage (t)	Radius (R)	Gage (t)	Radius (R)
.016	.015	.016	.015	.016	.015
.020	.015	.020	.015	.020	.015
.025	.015	.025	.015	.025	.031
.032	.015	.032	.031	.032	.031
.040	.015	.040	.031	.040	.031
.050	.015	.050	.031	.050	.046
.063	.031	.063	.046	.063	.046
.071	.031	.071	.046	.071	.062
.080	.031	.080	.046	.080	.062
.090	.031	.090	.062	.090	.062
.100	.031	.100	.062	.100	.078
.125	.046	.125	.078	.125	.093
.187	.046	.187	.109	.187	.125

TABLE IA-17
 MINIMUM BEND RADIUS LIMITS
 J-1570 (SOLUTION TREATED)
 TRANSVERSE GRAIN DIRECTION

$\alpha = 60^\circ$		$\alpha = 90^\circ$		$\alpha = 120^\circ$	
Gage (t)	Radius (R)	Gage (t)	Radius (R)	Gage (t)	Radius (R)
.016	.015	.016	.015	.016	.015
.020	.015	.020	.015	.020	.031
.025	.015	.025	.031	.025	.031
.032	.015	.032	.031	.032	.031
.040	.015	.040	.031	.040	.046
.050	.031	.050	.046	.050	.046
.063	.031	.063	.046	.063	.062
.071	.031	.071	.062	.071	.062
.080	.031	.080	.062	.080	.078
.090	.046	.090	.062	.090	.078
.100	.046	.100	.078	.100	.093
.125	.046	.125	.093	.125	.109
.187	.078	.187	.125	.187	.156

TABLE 1A-18
 MINIMUM BEND RADIUS LIMITS
 MOLYBDENUM (.5% Ti)
 (HOT ROLLED, STRESS RELIEVED, DE-SCALED SHEET)
 LONGITUDINAL GRAIN DIRECTION

$\alpha = 60^\circ$		$\alpha = 90^\circ$		$\alpha = 120^\circ$	
Gage (t)	Radius (R)	Gage (t)	Radius (R)	Gage (t)	Radius (R)
.016	.015	.016	.031	.016	.031
.020	.015	.020	.031	.020	.031
.025	.031	.025	.031	.025	.046
.032	.031	.032	.046	.032	.046
.040	.031	.040	.046	.040	.062
.050	.046	.050	.062	.050	.078
.063	.046	.063	.078	.063	.093
.071	.062	.071	.093	.071	.093
.080	.062	.080	.093	.080	.109
.090	.062	.090	.109	.090	.125
.100	.078	.100	.125	.100	.140
.125	.093	.125	.140	.125	.171
.187	.125	.187	.218	.187	.250

TABLE IA-19
 MINIMUM BEND RADIUS LIMITS
 MOLYBDENUM (.5% Ti)
 (HOT ROLLED, STRESS RELIEVED, DE-SCALED SHEET)
 TRANSVERSE GRAIN DIRECTION

$\alpha = 60^\circ$		$\alpha = 90^\circ$		$\alpha = 120^\circ$	
Gage (t)	Radius (R)	Gage (t)	Radius (R)	Gage (t)	Radius (R)
.016	.031	.016	.031	.016	.046
.020	.031	.020	.046	.020	.046
.025	.031	.025	.062	.025	.062
.032	.046	.032	.078	.032	.078
.040	.046	.040	.093	.040	.093
.050	.062	.050	.109	.050	.109
.063	.078	.063	.125	.063	.140
.071	.078	.071	.156	.071	.156
.080	.093	.080	.171	.080	.187
.090	.109	.090	.187	.090	.203
.100	.109	.100	.203	.100	.218
.125	.140	.125	.250	.125	.281
.187	.203	.187	.375	.187	.437

TABLE IA-20
 MINIMUM BEND RADIUS LIMITS
 AT ELEVATED TEMPERATURES
 HM21XA-T8 (MAGNESIUM THORIUM)
 LONGITUDINAL AND TRANSVERSE
 GRAIN DIRECTION

$\alpha = 90^\circ$					
Temp. = 200°F		Temp. = 400°F		Temp. = 600°F	
Gage (t)	Radius (R)	Gage (t)	Radius (R)	Gage (t)	Radius (R)
.016	.078	.016	.046	.016	.015
.020	.109	.020	.062	.020	.015
.025	.125	.025	.078	.025	.015
.032	.156	.032	.093	.032	.015
.040	.187	.040	.109	.040	.015
.050	.234	.050	.140	.050	.015
.063	.312	.063	.171	.063	.015
.071	.343	.071	.203	.071	.015
.080	.375	.080	.218	.080	.015
.090	.437	.090	.250	.090	.015
.100	.468	.100	.281	.100	.015
.125	.625	.125	.343	.125	.031
.187	1.000	.187	.562	.187	.031

TABLE IA-21
 MINIMUM BEND RADIUS LIMITS
 AT ELEVATED TEMPERATURES
 BERYLLIUM (PURE) (CONDITION "C")*
 LONGITUDINAL GRAIN DIRECTION

$\alpha = 90^\circ$					
Temp. = 1000 °F		Temp. = 1100 °F		Temp. = 1200 °F	
Gage (t)	Radius (R)	Gage (t)	Radius (R)	Gage (t)	Radius (R)
.016	.140	.016	.093	.016	.078
.020	.156	.020	.109	.020	.093
.025	.203	.025	.140	.025	.109
.032	.281	.032	.187	.032	.140
.040	.343	.040	.218	.040	.187
.050	.406	.050	.281	.050	.218
.063	.500	.063	.343	.063	.281
.071	.562	.071	.406	.071	.312
.080	.687	.080	.437	.080	.375
.090	.750	.090	.500	.090	.406
.100	.812	.100	.562	.100	.468
.125	1.000	.125	.687	.125	.562
.187	1.500	.187	1.000	.187	.812

*Material as rolled and stress annealed for 10 minutes at 1400 °F.

TABLE IA-22
 MINIMUM BEND RADIUS LIMITS
 AT ELEVATED TEMPERATURES
 BERYLLIUM (PURE) (CONDITION "C")*
 TRANSVERSE GRAIN DIRECTION

$\alpha = 90^\circ$					
Temp. = 1100°F		Temp. = 1200°F		Temp. = 1400°F	
Gage (t)	Radius (R)	Gage (t)	Radius (R)	Gage (t)	Radius (R)
.016	.140	.016	.125	.016	.093
.020	.156	.020	.140	.020	.109
.025	.203	.025	.187	.025	.140
.032	.281	.032	.234	.032	.171
.040	.343	.040	.281	.040	.218
.050	.406	.050	.343	.050	.281
.063	.500	.063	.437	.063	.343
.071	.502	.071	.500	.071	.375
.080	.687	.080	.562	.080	.437
.090	.750	.090	.625	.090	.468
.100	.812	.100	.750	.100	.562
.125	1.000	.125	.812	.125	.687
.187	1.500	.187	1.375	.187	1.000

*Material as rolled and stress annealed for 10 minutes at 1400°F.

TABLE IA-23
 MINIMUM BEND RADIUS LIMITS
 AT ELEVATED TEMPERATURES
 TUNGSTEN (PURE) .020 GAGE
 LONGITUDINAL AND TRANSVERSE
 GRAIN DIRECTION

$\alpha = 90^\circ$					
Temp. = 300 °F		Temp. = 550 °F		Temp. = 800 °F	
Gage (t)	Radius (R)	Gage (t)	Radius (R)	Gage (t)	Radius (R)
.016	.125	.016	.125	.016	.125
.020	.156	.020	.156	.020	.156
.025	.203	.025	.187	.025	.187
.032	.250	.032	.234	.032	.234
.040	.312	.040	.312	.040	.281
.050	.406	.050	.375	.050	.375
.063	.500	.063	.468	.063	.468
.071	.562	.071	.562	.071	.500
.080	.625	.080	.625	.080	.562
.090	.750	.090	.687	.090	.687
.100	.812	.100	.750	.100	.750
.125	1.000	.125	1.000	.125	1.000
.187	1.500	.187	1.375	.187	1.375

TABLE IA-24
 MINIMUM BEND RADIUS LIMITS
 AT ELEVATED TEMPERATURES
 TUNGSTEN (PURE) .040 GAGE
 LONGITUDINAL AND TRANSVERSE
 GRAIN DIRECTION

$\alpha = 90^\circ$					
Temp. = 200°F		Temp. = 400°F		Temp. = 600°F	
Gage (t)	Radius (R)	Gage (t)	Radius (R)	Gage (t)	Radius (R)
.016	.031	.016	.015	.016	.015
.020	.031	.020	.015	.020	.015
.025	.031	.025	.015	.025	.015
.032	.046	.032	.031	.032	.031
.040	.046	.040	.031	.040	.031
.050	.062	.050	.031	.050	.031
.063	.078	.063	.046	.063	.046
.071	.078	.071	.046	.071	.046
.080	.093	.080	.062	.080	.046
.090	.093	.090	.062	.090	.046
.100	.109	.100	.062	.100	.062
.125	.140	.125	.078	.125	.062
.187	.203	.187	.125	.187	.093

JOGGLING

Description of the Process

The forming of joggles or offsets are common operations in the metal working industry. There are several techniques or forming methods used in the process of forming a joggle; however, for the scope of this program a Universal joggling machine made by Joggle Tool and Die, Incorporated, installed on a knuckle-joint 100 ton Hamilton Mechanical Press was used. This type of machine was selected for joggling analysis because it was adaptable to forming a large number of parts.

With the help of the illustration shown in Figure IB-1, a better understanding of this particular mechanical process of joggling can be obtained.

The description of the mechanical process is as follows: Joggle block (C) is adjusted to a certain distance to obtain the desired length of travel (L). Shims are placed above (C) and below (B) to obtain the desired joggle depth (D). (B) is spring loaded so that the block can recess downward to a desired depth (D); while (A) along with a top clamping plate (not shown in illustration) remains at a stationary position, thus holding the upper step of the joggle specimen firmly. (E) is a side clamping vice-force which holds the buckling area of the joggle part inward tightly.

The information obtained from the Universal joggling process investigation can be used for other types or techniques of joggling. Some of the other possibilities are: shim joggling, replaceable block type joggling, and special type joggling.

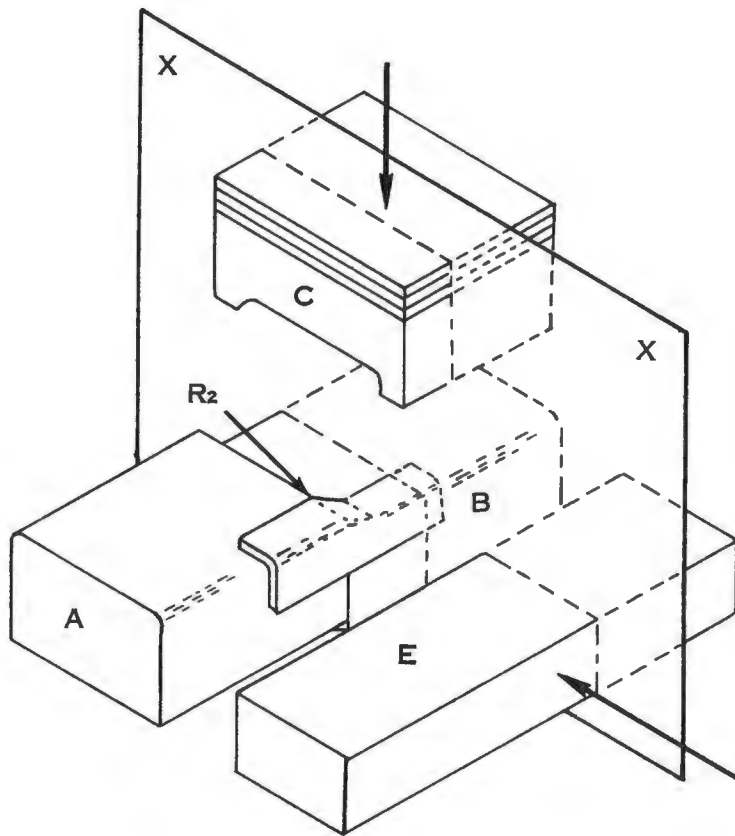
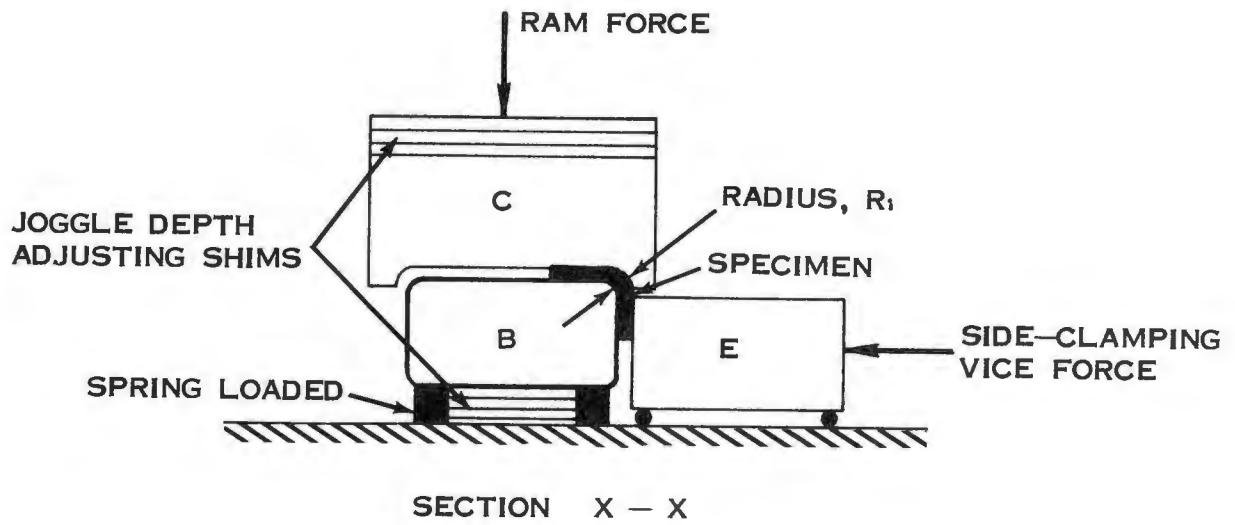

FIGURE IB-1 SCHEMATIC OF JOGGLE DIES

This program covered only the joggling of angle sections. However, similar relationships can be applied to channel sections, hat sections, and various other configurations of the joggling process.

It should be understood that when forming any type joggle, special care should be taken to insure that proper tooling is used. That is, a good joggle cannot be expected if a proper set-up is not used. Care should be taken to insure proper material clearance, proper vice holding action, proper flange radius and that properly matched dies are being used.

If a good machine set-up and good shop joggling procedures are used, joggles with the recommended dimensions selected from the composite graphs and design tables of this report will yield perfect joggles.

Definition of Part Shape and Geometrical Variables

Formability of joggled parts is governed primarily by these geometrical parameters: The depth of the joggle (D), the length of the joggle (L), the gage or thickness of material (t), D/L and D/t . These parameters are shown in their proper location on the joggle specimen sketch shown in Figure IB-2.

Two very critical radii are encountered in the joggling process. First, the joggling block radius to which the joggle specimen was matched to a 90° bend angle. This radius is called R_1 and is shown in Figure IB-2. Second, the bend radius located on the leading edge of joggle block (A).

This radius is also shown in Figure IB-2 and is called R_2 . Radius R_2 is set at a standard radius of 0.032". It can be seen from the discussion later in this section that R_2 must be increased to form certain type of materials that fail due to the minimum bend radius. Also, by increasing the radius of R_2 , an increase in the splitting limits of all materials occur progressively.

R_1 radius was established at a value of $R/t = 6$. That is, R_1 is six times the thickness of the material to be formed. This is done to eliminate failure of the joggle specimen due to the minimum bend radius of the material in forming the 90° flange on the joggle specimen.

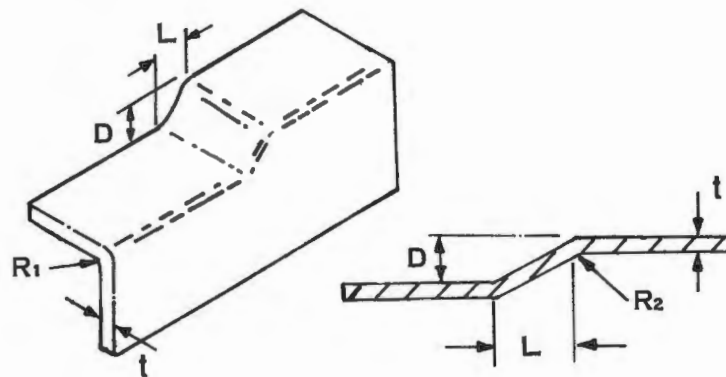

FIGURE IB-2 GEOMETRICAL PARAMETERS OF A JOGGLE.

Predictability Equations

The equation for the splitting limit of any material based on its mechanical properties is:

$$\frac{D}{L} = \left[\epsilon_{.02} (1.44 \epsilon_{.02} + 2.4) \right]^{\frac{1}{2}} \quad \text{Equation I}$$

The equation for the elastic buckling limit line is:

$$\frac{D}{L} = \frac{E}{S_{cy}} \left[\frac{.0050625}{\left(\frac{D}{t}\right)^2} \right] \quad \text{Equation II}$$

The equation for the elasto-plastic buckling limit line is:

$$\frac{D}{t} = \left[.0118 \frac{E}{S_{cy}} \right]^{\frac{2}{5}} \quad \text{Equation III}$$

The equation for the inflection line is as follows. This line is at a slope of $(+\frac{1}{2})$ and crosses the D/L axis at 0.43.

$$\frac{D}{L} = 0.43 \sqrt{\frac{D}{t}} \quad \text{Equation IV}$$

The equation for finding the intersection of the elasto-plastic and elastic buckling limit line at a point on the inflection line is:

$$\frac{D}{t} = \left[.0118 \frac{E}{S_{cy}} \right]^{\frac{2}{5}} \quad \text{Equation V}$$

The buckling formability index line runs vertically upward from the D/t intercept 2.25.

For the convenience of reference to the above mentioned equations, a typical theoretical formability curve is shown in Figure IB-3.

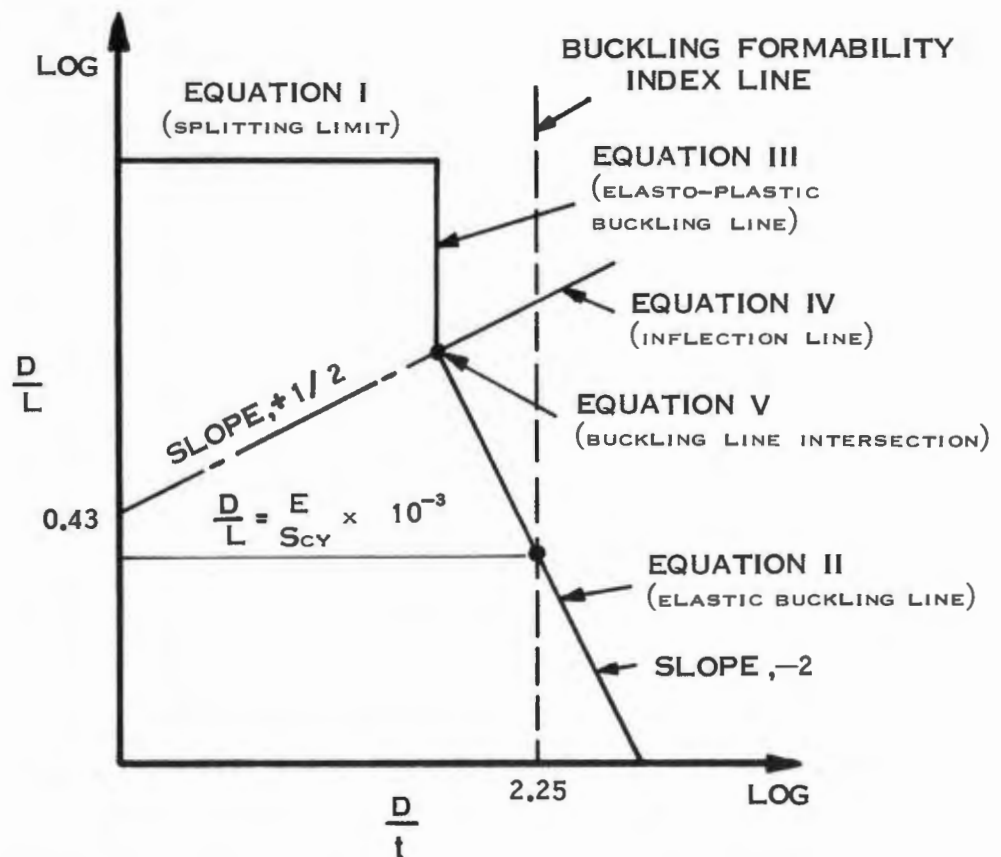

FIGURE IB-3 TYPICAL JOGGLING FORMABILITY CURVE.

The key to using the various equations is to know the following material properties: E , Scy , $\epsilon .02$ and $E/Scy \times 10^{-3}$.

$(E/Scy \times 10^{-3})$ - Where $E/Scy \times 10^{-3}$ is the joggling formability index. 10^{-3} is a constant of convenience used so that E/Scy and D/L can be plotted at same scale value.

Thus, if these material properties are known, the joggling formability of any material can be determined.

To demonstrate how to use the juggling predictability equations, the following example problem is given:

PROBLEM: Find juggling limits of 2024-0 aluminum.

GIVEN: (E) compressive modulus of elasticity = $\underline{10.8 \times 10^6}$

(S_{cy}) compressive yield strength = $\underline{14,600}$

($\epsilon .02$) strain = $\underline{.75}$

SOLUTION: Step I. - Find the splitting limit using Equation I.

Substitute in $\epsilon .02$ and solve for D/L intercept.

$$D/L = \left[\epsilon .02 (1.44 \epsilon .02 + 2.39) \right]^{\frac{1}{2}} = \underline{1.62} .$$

Draw in a horizontal splitting limit line from the D/L intercept $\underline{1.62}$. (See Figure IB-4).

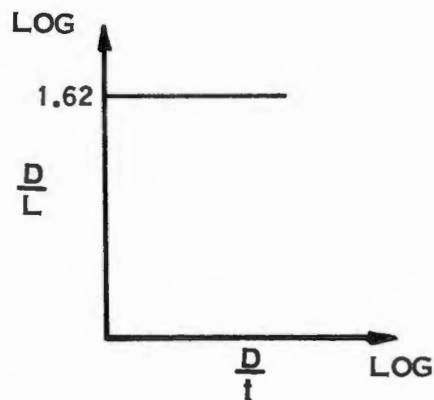

FIGURE IB-4 SPLITTING LIMIT LINE .

Step II. - Use equation V to find the intersection point of the elasto-plastic and elastic buckling limit line at a point on the inflection line. Substitute in E/Scy and solve for D/t.

$$D/t = \left[.0118 \ E/Scy \right]^{2/5} = \underline{2.38}.$$

Step III.- Substitute in D/t value found in Step II and solve for D/L in Equation IV. (Inflection line equation).

$$D/L = 0.43 \sqrt{D/t} = \underline{.664}.$$

Next, draw in the D/L value (from Step III) on the inflection line. Through this point draw a (-2) slope and a vertical line upward to the splitting limit line (found in Step I). (See Figure IB-5)

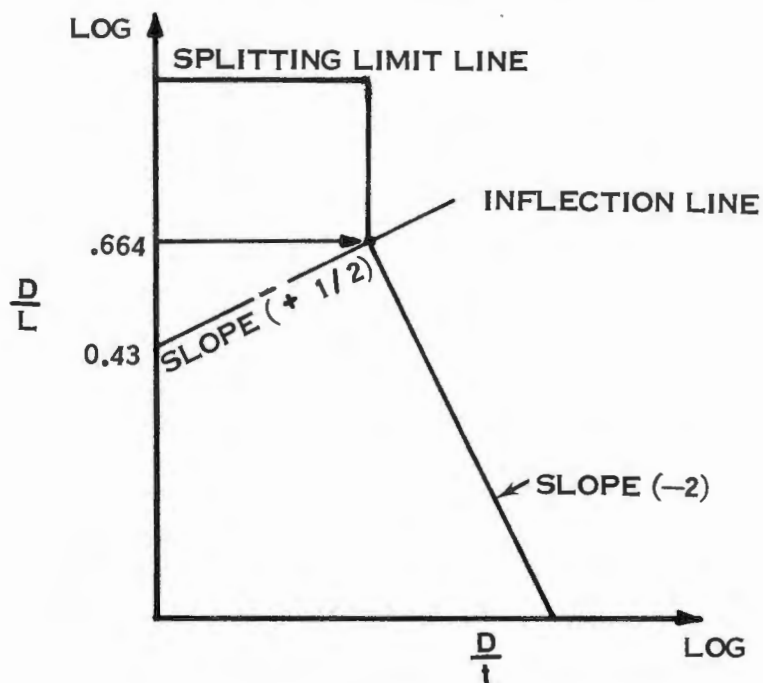

FIGURE IB-5 GRAPH CONSTRUCTION.

Thus, a completely inclosed formability curve is constructed. All points inclosed in the envelope will be good parts, while those lying outside the envelope will either fail due to buckling or splitting depending on the region of the curve. A sketch of this typical formability envelope curve is shown in Figure IB-6.

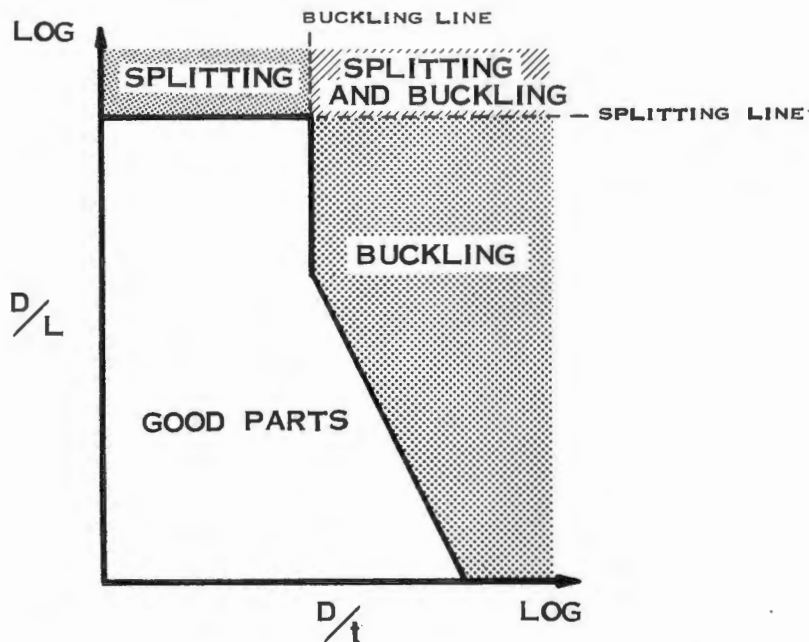

FIGURE IB-6 TYPICAL FORMABILITY ENVELOPE .

An alternate method that can be used to solve for the joggling limits is as follows:

- Step I - Repeat Step I as was outlined in first method.
- Step II - Locate $E/S_{cy} \times 10^{-3} = (.743)$ value on vertical formability index line ($D/t = 2.25$ line). From this point draw a (-2) slope from the inflection line through this point. (See Figure IB-7).

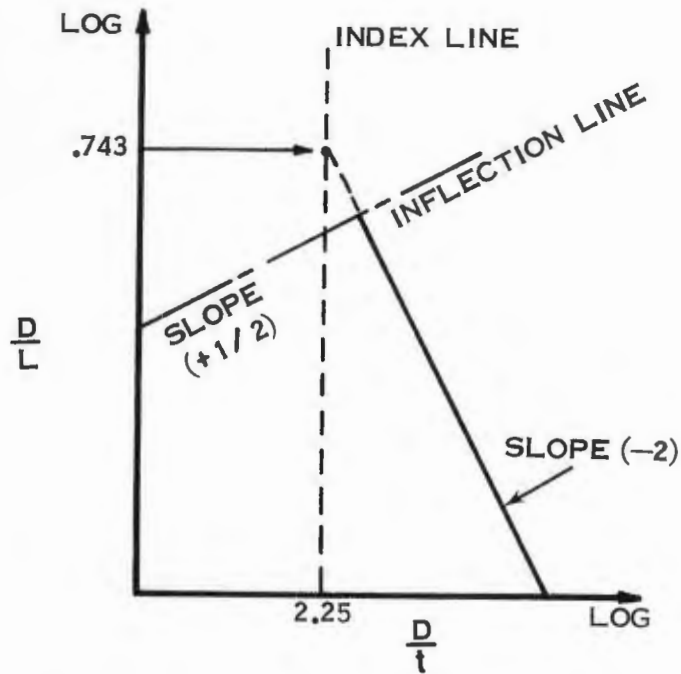

FIGURE IB-7 GRAPH CONSTRUCTION.

Step III - Draw a vertical line from the intersection point of the (-2) slope and the inflection line up to the splitting limit line. (See Figure IB-8).

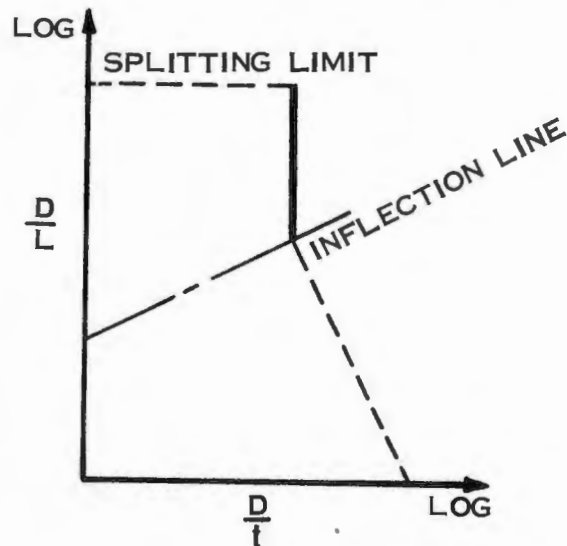

FIGURE IB-8 GRAPH CONSTRUCTION.

Composite Graphs

A composite graph showing the joggling formability limits of the 19 different materials used in this program is shown in Graph IB-1.

All materials are shown at room temperature except for HM21XA-T8, Tungsten, (6Al-4V) Titanium, and Beryllium. These materials are shown at recommended elevated temperatures due to their high fracture tendency and relative unformable characteristics at room temperature. (6Al-4V) Titanium was not shown at elevated temperature due to the unavailability of tensile information at elevated temperature.

The composite theoretical formability curves for joggling were established at a point where there should be relatively no handworking necessary, that is, no buckling or splitting failures occurring. It should be understood however, that the E/S_{cy} was taken at a minimum value. Thus, there is a maximum, average and minimum value for E/S_{cy} and this should be taken into account when predicting the formability of any material. An example of how these different E/S_{cy} values will affect the buckling limit curves is illustrated in Figure IB-9.

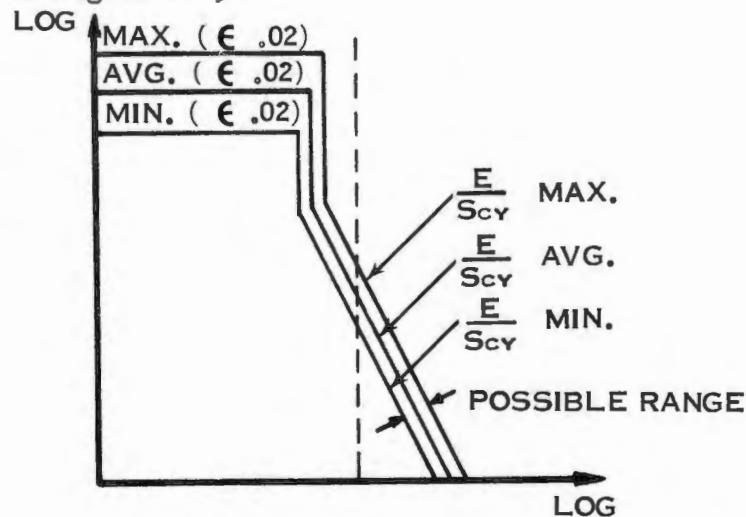

FIGURE IB-9 VARIATION OF MATERIAL PROPERTIES.

It can also be seen from Figure IB-9 that the same relationship will occur for the splitting limit line. That is, $\epsilon .02$ also has a maximum, average and minimum value.

All splitting limits in the composite graphs are established for a standard 0.032" die radius (R_2). (See discussion under geometrical parameters.) If the splitting limits of any of the materials listed needed to be raised, the (R_2) radius can be increased. That is, as the (R_2) radius is increased, the splitting limits of all materials will also increase.

An example of this concept is shown in Figure IB-10.

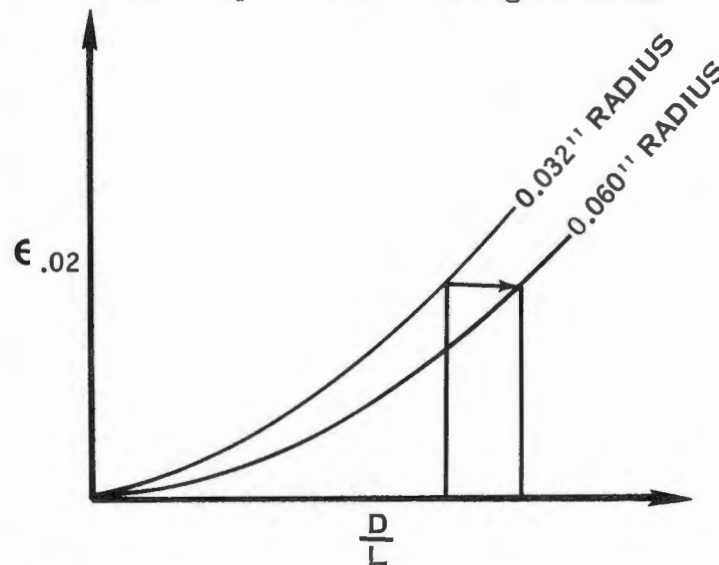

FIGURE IB-10 SPLITTING LIMIT LINE.

The curve shows that as the standard 0.032" radius is increased to 0.060", there is also an increase in the D/L splitting limit value. Additional curves may be plotted showing an increase in the (R_2) radius along with a corresponding increase in the D/L splitting limit value.

It can be seen that the composite graph is constructed on a logarithmic basis. However, for the convenience of finding the depth of the joggle (D) and the length of the joggle (L) for a certain material thickness (t) directly, an alternate method of plotting is advised.

This is done by taking a certain material (2024-0 aluminum) from the logarithmic composite graph (Graph IB-1) and replotting the information on a Cartesian coordinate graph. (See Graph IB-2). Thus the values of D, L and t can be read directly from this type of graph (Graph IB-2).

GRAPH I B-1
COMPOSITE GRAPH FOR JOGGLING

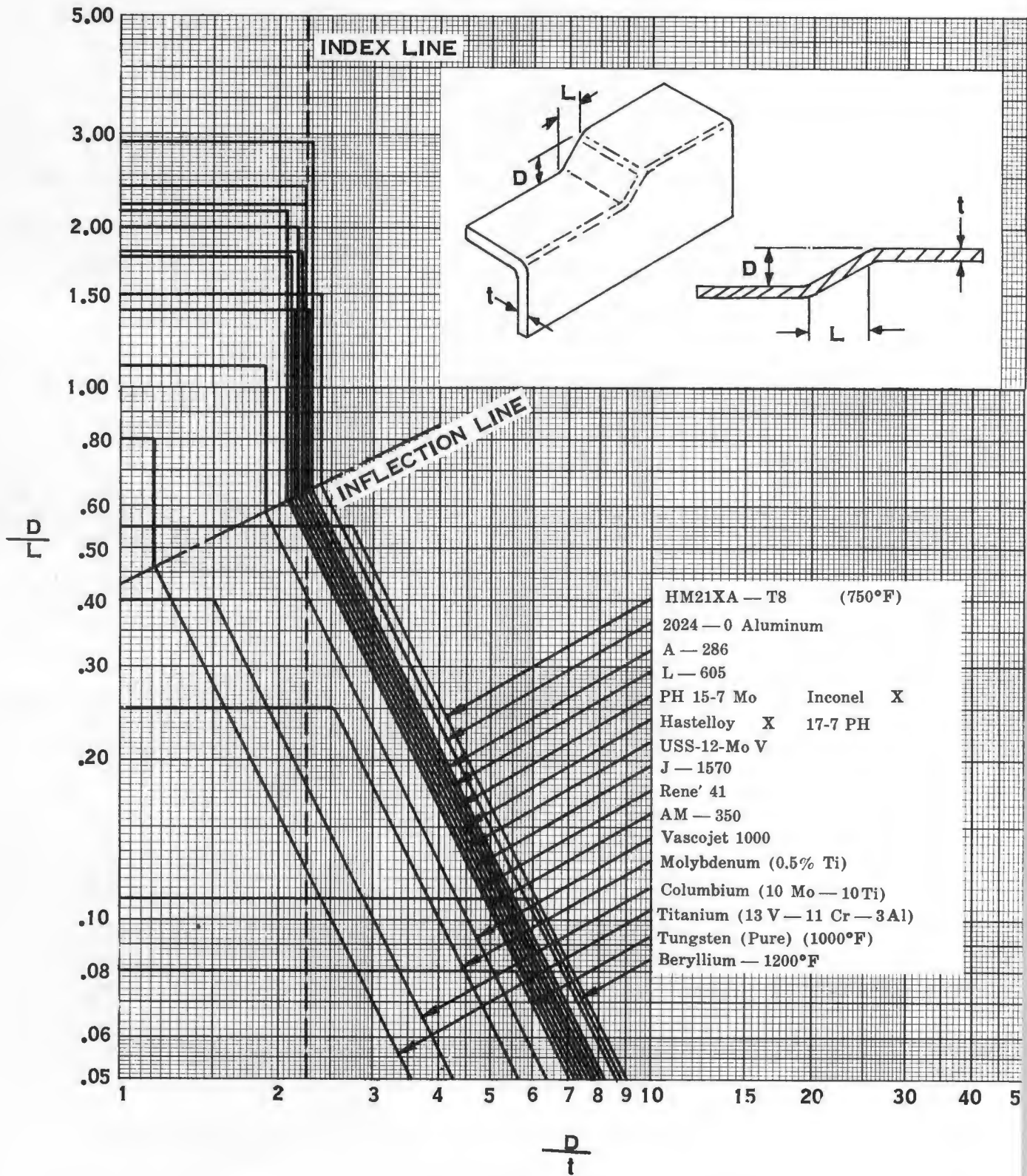

GRAPH I B-2
JOGGLING LIMITS FOR
2024-0 ALUMINUM

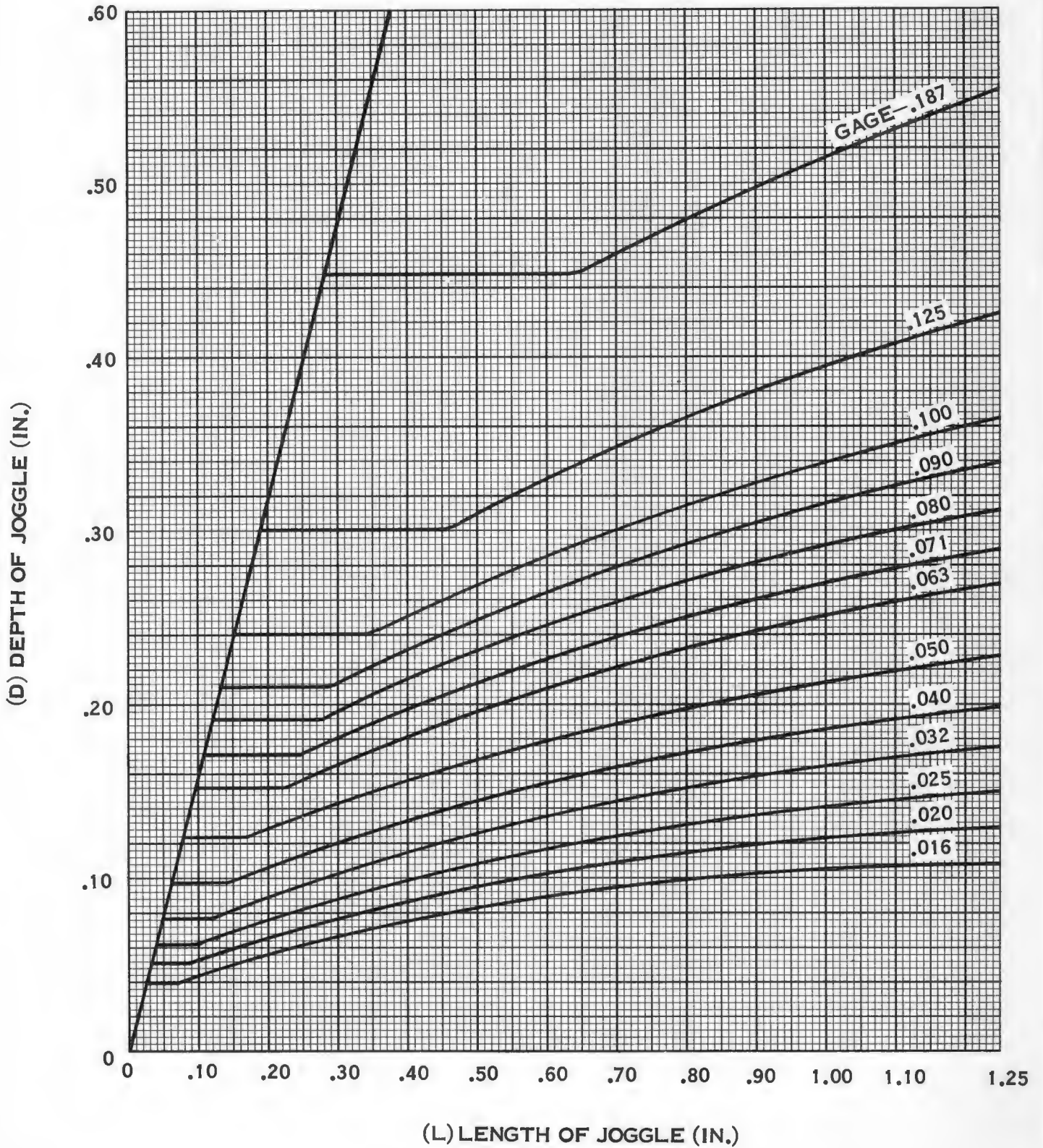

Design Tables

The design tables give the recommended values for the depth of the joggle (D), length of the joggle (L), and the thickness of the material (t).

Thus, by having a given (t) and a given (L), the recommended (D) value can be read from the tables. Or, by having a given (D) and a given (t) the recommended value of (L) can be read from the tables.

TABLE IB-1
 JOGGLE DEPTH LIMITS
 HM21XA-T8 (MAGNESIUM THORIUM)
 TEMPERATURE 750°F

GAGE (t)	.016	.020	.025	.032	.040	.050	.063	.071	.080	.090	.100	.125	.187
LENGTH (L)	JOGGLE DEPTH (D)												
.10	.048	.053	.056	.056	.056	.056							
.20	.060	.070	.080	.090	.112	.112	.112	.112	.112	.112	.112		
.30	.071	.076	.093	.106	.126	.144	.168	.168	.168	.168	.168	.168	
.40	.073	.090	.104	.124	.140	.164	.192	.200	.224	.224	.224	.224	.224
.50	.076	.095	.112	.130	.155	.175	.205	.220	.230	.250	.280	.280	.280
.60	.084	.102	.118	.138	.159	.186	.216	.228	.252	.276	.288	.336	.336
.70	.091	.105	.123	.147	.168	.192	.224	.252	.265	.295	.315	.350	.392
.80	.092	.108	.130	.152	.184	.204	.240	.256	.280	.304	.328	.384	.440
.90	.099	.113	.135	.157	.189	.216	.248	.261	.288	.315	.338	.396	.477
1.00	.105	.120	.140	.165	.190	.222	.257	.275	.305	.330	.350	.410	.500

TABLE IB-2
 JOGGLE DEPTH LIMITS
 2024-O ALUMINUM

GAGE (t)	.016	.020	.025	.032	.040	.050	.063	.071	.080	.090	.100	.125	.187
LENGTH (L)	JOGGLE DEPTH (D)												
.10	.045	.054	.062	.077	.097	.120	.151	.160	.168	.170	.165	.198	.224
.20	.059	.068	.080	.093	.108	.125	.151	.170	.192	.216	.240	.300	.327
.30	.067	.078	.090	.107	.124	.145	.167	.184	.198	.216	.240	.300	.448
.40	.073	.085	.099	.117	.136	.159	.182	.199	.212	.234	.251	.300	.448
.50	.079	.092	.106	.125	.147	.170	.197	.213	.231	.252	.270	.312	.448
.60	.083	.098	.114	.134	.155	.180	.210	.231	.248	.268	.287	.332	.448
.70	.088	.104	.120	.139	.164	.190	.223	.240	.264	.285	.305	.354	.458
.80	.092	.108	.124	.148	.173	.198	.233	.252	.272	.296	.317	.368	.483
.90	.096	.110	.129	.155	.178	.204	.240	.263	.281	.306	.329	.384	.497
1.00	.099	.115	.134	.159	.183	.207	.250	.271	.291	.315	.340	.396	.518

TABLE IB-3
 JOGGLE DEPTH LIMITS
 17-7 PH STAINLESS STEEL
 (MILL ANNEALED, CONDITION "A")

GAGE (t)	.016	.020	.025	.032	.040	.050	.063	.071	.080	.090	.100	.125	.187
LENGTH (L)	JOGGLE DEPTH (D)												
.10	.042	.050	.058	.070	.088	.110	.138	.156	.176	.198	.200	.188	.224
.20	.053	.062	.073	.087	.100	.115	.138	.156	.176	.198	.220	.275	.392
.30	.061	.072	.083	.098	.114	.133	.153	.171	.180	.198	.220	.275	.412
.40	.067	.078	.090	.110	.124	.145	.170	.188	.200	.216	.235	.275	.412
.50	.072	.084	.097	.117	.134	.156	.185	.204	.216	.239	.258	.294	.412
.60	.075	.089	.104	.123	.143	.165	.194	.212	.228	.248	.268	.308	.412
.70	.078	.094	.109	.129	.151	.174	.208	.219	.237	.257	.280	.330	.421
.80	.082	.098	.114	.134	.157	.182	.214	.230	.250	.267	.290	.338	.444
.90	.085	.101	.118	.139	.163	.191	.220	.242	.259	.280	.300	.350	.457
1.00	.085	.104	.122	.143	.168	.196	.230	.249	.268	.295	.310	.362	.478

TABLE IB-4
 JOGGLE DEPTH LIMITS
 PH 15-7 Mo STAINLESS STEEL
 (MILL ANNEALED, CONDITION "A")

GAGE (t)	.016	.020	.025	.032	.040	.050	.063	.071	.080	.090	.100	.125	.187
LENGTH (L)	JOGGLE DEPTH (D)												
.10	.041	.049	.057	.070	.088	.110	.138	.156	.176	.198	.220	.275	.390
.20	.052	.060	.073	.087	.100	.115	.138	.156	.176	.198	.220	.275	.412
.30	.061	.072	.083	.098	.114	.133	.154	.171	.180	.198	.220	.275	.412
.40	.067	.078	.090	.110	.124	.145	.171	.188	.200	.216	.235	.275	.412
.50	.073	.084	.097	.118	.134	.156	.186	.204	.216	.239	.259	.294	.412
.60	.076	.089	.104	.124	.143	.165	.196	.212	.228	.248	.269	.308	.412
.70	.079	.094	.109	.130	.151	.174	.209	.220	.238	.257	.283	.330	.423
.80	.084	.098	.115	.135	.157	.183	.215	.232	.251	.268	.294	.339	.448
.90	.087	.103	.119	.141	.164	.193	.223	.243	.260	.281	.305	.354	.463
1.00	.087	.106	.123	.146	.169	.199	.234	.252	.270	.297	.316	.369	.483

TABLE IB-5
 JOGGLE DEPTH LIMITS
 AM-350 STAINLESS STEEL
 (ANNEALED)

GAGE (t)	.016	.020	.025	.032	.040	.050	.063	.071	.080	.090	.100	.125	.187
LENGTH (L)	JOGGLE DEPTH (D)												
.10	.039	.046	.053	.064	.080	.100	.126	.142	.160	.180	.200	.200	.200
.20	.048	.056	.065	.079	.092	.106	.126	.142	.160	.180	.200	.250	.375
.30	.056	.066	.076	.089	.103	.120	.142	.154	.173	.180	.200	.250	.375
.40	.062	.072	.083	.099	.114	.134	.156	.169	.185	.198	.213	.250	.375
.50	.068	.078	.090	.107	.123	.144	.169	.184	.197	.213	.231	.263	.375
.60	.071	.083	.096	.114	.132	.153	.179	.193	.209	.228	.244	.282	.375
.70	.074	.087	.100	.119	.139	.161	.188	.202	.220	.239	.258	.300	.388
.80	.077	.091	.105	.124	.145	.168	.196	.212	.230	.249	.269	.311	.411
.90		.094	.110	.129	.150	.175	.204	.222	.240	.258	.277	.325	.425
1.00		.097	.114	.133	.155	.181	.211	.230	.248	.266	.286	.333	.440

TABLE IB-6
 JOGGLE DEPTH LIMITS
 A-286 STAINLESS STEEL
 (SOLUTION TREATED CONDITION)

GAGE (t)	.016	.020	.025	.032	.040	.050	.063	.071	.080	.090	.100	.125	.187
LENGTH (L)	JOGGLE DEPTH (D)												
.10	.044	.051	.059	.073	.092	.115	.145	.163	.183	.206	.230	.286	.430
.20	.053	.062	.072	.088	.102	.119	.145	.163	.183	.206	.230	.286	.430
.30	.062	.073	.084	.099	.115	.134	.158	.171	.187	.206	.230	.286	.430
.40	.068	.080	.092	.109	.128	.149	.175	.186	.204	.213	.238	.286	.430
.50	.074	.087	.100	.118	.137	.159	.187	.202	.218	.233	.256	.298	.430
.60	.079	.092	.106	.126	.145	.169	.199	.219	.232	.252	.271	.316	.430
.70	.083	.096	.112	.132	.153	.178	.209	.227	.244	.266	.284	.334	.440
.80	.087	.101	.117	.138	.160	.186	.218	.234	.256	.279	.297	.350	.455
.90	.090	.105	.121	.143	.167	.193	.227	.244	.265	.289	.310	.366	.472
1.00	.092	.108	.125	.147	.173	.200	.236	.255	.274	.298	.321	.374	.490

TABLE IB-7
 JOGGLE DEPTH LIMITS
 USS-12-MoV STAINLESS STEEL
 (ANNEALED)

GAGE (t)	.016	.020	.025	.032	.040	.050	.063	.071	.080	.090	.100	.125	.187
LENGTH (L)	JOGGLE DEPTH (D)												
.10	.042	.048	.057	.068	.086	.107	.135	.135	.140	.138	.148	.162	.187
.20	.053	.059	.069	.085	.097	.112	.135	.152	.172	.194	.215	.269	.280
.30	.059	.070	.081	.095	.109	.127	.151	.167	.176	.194	.215	.269	.403
.40	.065	.077	.089	.105	.121	.141	.166	.180	.193	.210	.226	.269	.403
.50	.070	.083	.096	.113	.130	.152	.180	.193	.208	.225	.241	.304	.403
.60	.075	.088	.102	.120	.139	.161	.190	.204	.222	.239	.260	.312	.403
.70	.079	.092	.107	.126	.146	.170	.200	.215	.234	.251	.270	.320	.411
.80	.083	.096	.113	.132	.153	.178	.209	.224	.246	.263	.279	.333	.428
.90	.089	.100	.118	.137	.159	.186	.218	.233	.255	.273	.286	.346	.445
1.00	.095	.103	.120	.141	.165	.193	.226	.241	.264	.282	.295	.353	.460

TABLE IB-8
 JOGGLE DEPTH LIMITS
 TITANIUM (13V-11Cr-3Al)
 (SOLUTION TREATED CONDITION)

GAGE (t)	.016	.020	.025	.032	.040	.050	.063	.071	.080	.090	.100	.125	.187
LENGTH (L)	JOGGLE DEPTH (D)												
.10	.026	.030	.037	.040	.047	.055	.069	.078	.080	.087	.090	.100	
.20	.032	.037	.045	.050	.058	.067	.081	.088	.095	.102	.110	.137	
.30	.037	.043	.049	.059	.068	.079	.092	.099	.108	.117	.126	.158	.203
.40	.041	.047	.054	.064	.075	.087	.102	.110	.120	.129	.138	.163	.204
.50		.051	.059	.069	.081	.094	.110	.118	.131	.140	.150	.172	.222
.60			.062	.073	.086	.100	.117	.126	.139	.148	.161	.184	.239
.70			.065	.077	.090	.105	.123	.133	.146	.155	.168	.195	.254
.80				.081	.094	.110	.128	.139	.151	.162	.175	.204	.268
.90					.097	.114	.133	.145	.156	.168	.181	.212	.278
1.00					.100	.117	.138	.150	.160	.173	.184	.219	.288

TABLE IB-9
 JOGGLE DEPTH LIMITS
 VASCCJET 1000 (H-11)
 (ANNEALED)

GAGE (t)	.016	.020	.025	.032	.040	.050	.063	.071	.080	.090	.100	.125	.187
LENGTH (L)	JOGGLE DEPTH (D)												
.10	.038	.044	.051	.057	.072	.091	.107	.106	.109	.112	.110	.100	.090
.20	.046	.053	.062	.072	.087	.102	.116	.129	.145	.163	.182	.227	.223
.30	.054	.061	.072	.086	.100	.117	.135	.150	.156	.172	.182	.227	.342
.40	.059	.068	.080	.093	.109	.127	.148	.162	.173	.188	.208	.233	.342
.50	.064	.075	.087	.099	.118	.137	.161	.174	.089	.203	.217	.252	.342
.60	.068	.079	.092	.107	.125	.147	.170	.184	.201	.216	.236	.270	.358
.70	.072	.083	.097	.114	.132	.156	.179	.194	.212	.228	.245	.285	.376
.80	.075	.087	.101	.119	.139	.163	.189	.202	.220	.238	.257	.300	.394
.90	.076	.091	.105	.124	.145	.169	.198	.210	.227	.247	.267	.317	.407
1.00	.076	.093	.108	.128	.151	.175	.207	.215	.233	.255	.276	.334	.420

TABLE IB-10
 JOGGLE DEPTH LIMITS
 BERYLLIUM (PURE)
 (CONDITION "C")
 TEMPERATURE 1200 °F

GAGE (t)	.016	.020	.025	.032	.040	.050	.063	.071	.080	.090	.100	.125	.187
LENGTH (L)	JOGGLE DEPTH (D)												
.10	.0096	.011	.011	.011	.011	.011	.011	.011	.011	.011	.011	.011	
.20	.0122	.0132	.0156	.018	.022	.022	.022	.022	.022	.022	.022	.022	.022
.30	.0138	.015	.0177	.021	.0243	.0276	.033	.033	.033	.033	.033	.033	.033
.40	.0152	.0168	.0196	.0228	.0264	.0303	.0368	.040	.044	.044	.044	.044	.044
.50	.0165	.0180	.0205	.0245	.0285	.033	.0389	.0422	.045	.0475	.055	.055	.055
.60	.0168	.0192	.0212	.0258	.030	.0346	.0411	.0444	.0476	.0515	.0552	.066	.066
.70	.0165	.0193	.0221	.0280	.0315	.0361	.0434	.0466	.0504	.0560	.0580	.0658	.077
.80	.0176	.0216	.024	.0282	.0332	.0378	.0456	.0488	.0525	.0563	.0608	.0688	.088
.90	.0189	.0216	.0252	.0288	.0351	.0396	.0473	.0504	.0549	.0567	.0634	.0738	.099
1.00	.019	.0230	.0260	.031	.0360	.0410	.0490	.0520	.0560	.0600	.066	.077	.100

TABLE IB-11
 JOGGLE DEPTH LIMITS
 RENE '41
 (SOLUTION TREATED)

GAGE (t)	.016	.020	.025	.032	.040	.050	.063	.071	.080	.090	.100	.125	.187
LENGTH (L)	JOGGLE DEPTH (D)												
.10	.041	.047	.054	.067	.084	.105	.132	.149	.168				
.20	.050	.058	.066	.081	.094	.109	.132	.149	.168	.189	.210	.262	
.30	.058	.066	.078	.092	.106	.132	.144	.157	.172	.189	.210	.262	.382
.40	.063	.074	.086	.102	.117	.136	.158	.173	.187	.201	.218	.262	.382
.50	.068	.079	.093	.109	.126	.146	.172	.188	.202	.217	.235	.273	.382
.60	.073	.084	.099	.116	.135	.156	.183	.196	.214	.232	.250	.290	.382
.70	.077	.089	.104	.121	.142	.164	.194	.203	.225	.242	.264	.304	.392
.80	.079	.093	.108	.127	.149	.171	.200	.214	.235	.251	.273	.318	.405
.90	.080	.097	.111	.132	.154	.178	.205	.225	.244	.263	.282	.332	.422
1.00		.100	.114	.137	.159	.185	.209	.235	.252	.274	.291	.342	.440

TABLE IB-12
 JOGGLE DEPTH LIMITS
 INCONEL X
 (C.R. ANNEALED)

GAGE (t)	.016	.020	.025	.032	.040	.050	.063	.071	.080	.090	.100	.125	.187
LENGTH (L)	JOGGLE DEPTH (D)												
.10	.043	.050	.058	.072	.090	.112	.142	.160	.180	.202	.225	.200	.224
.20	.053	.062	.073	.086	.100	.117	.142	.160	.180	.202	.225	.280	.420
.30	.061	.072	.083	.096	.114	.132	.153	.167	.180	.202	.225	.280	.420
.40	.067	.078	.091	.107	.125	.145	.171	.184	.200	.214	.235	.280	.420
.50	.072	.084	.098	.115	.134	.157	.183	.199	.216	.234	.250	.294	.420
.60	.076	.089	.104	.122	.144	.167	.195	.212	.228	.246	.266	.308	.420
.70	.080	.094	.108	.128	.151	.175	.206	.221	.240	.258	.280	.323	.428
.80	.084	.098	.112	.134	.156	.183	.214	.233	.251	.271	.290	.338	.443
.90	.086	.100	.116	.139	.162	.191	.222	.242	.262	.284	.300	.350	.459
1.00	.087	.102	.121	.144	.168	.197	.228	.250	.268	.294	.310	.362	.472

TABLE IB-13
 JOGGLE DEPTH LIMITS
 HASTELLOY X
 (SOLUTION TREATED)

GAGE (t)	.016	.020	.025	.032	.040	.050	.063	.071	.080	.090	.100	.125	.187
LENGTH (L)	JOGGLE DEPTH (D)												
.10	.042	.050	.058	.070	.088	.110	.138	.156	.176	.198	.200	.200	.224
.20	.053	.061	.073	.087	.100	.115	.138	.156	.176	.198	.220	.275	.392
.30	.061	.072	.083	.098	.114	.133	.153	.171	.180	.198	.220	.275	.412
.40	.067	.078	.090	.110	.124	.145	.170	.188	.200	.216	.235	.275	.412
.50	.072	.084	.097	.117	.134	.156	.185	.204	.216	.239	.258	.294	.412
.60	.075	.089	.104	.123	.143	.165	.194	.212	.228	.248	.268	.308	.412
.70	.078	.094	.109	.129	.151	.174	.208	.219	.237	.257	.280	.330	.421
.80	.082	.098	.114	.134	.157	.182	.214	.230	.250	.267	.290	.338	.444
.90	.085	.101	.118	.139	.163	.191	.220	.242	.259	.280	.300	.350	.457
1.00	.085	.104	.122	.143	.168	.196	.230	.249	.268	.295	.310	.362	.478

TABLE IB-14
 JOGGLE DEPTH LIMITS
 L-605
 (SOLUTION TREATED)

GAGE (t)	.016	.020	.025	.032	.040	.050	.063	.071	.080	.090	.100	.125	.187
LENGTH (L)	JOGGLE DEPTH (D)												
.10	.041	.049	.057	.070	.088	.110	.138	.156	.176	.198	.200	.200	.224
.20	.052	.060	.073	.087	.100	.115	.138	.156	.176	.198	.220	.275	.392
.30	.061	.072	.083	.098	.114	.133	.154	.171	.180	.198	.220	.275	.412
.40	.067	.078	.090	.110	.124	.145	.171	.188	.200	.216	.235	.275	.412
.50	.072	.084	.097	.118	.134	.156	.186	.204	.216	.239	.258	.294	.412
.60	.075	.089	.104	.124	.143	.165	.195	.212	.228	.248	.268	.308	.412
.70	.079	.094	.109	.130	.151	.174	.208	.220	.238	.257	.282	.330	.423
.80	.083	.098	.115	.135	.157	.182	.215	.231	.251	.267	.292	.338	.447
.90	.086	.102	.119	.140	.163	.192	.222	.243	.260	.280	.303	.353	.461
1.00	.086	.105	.123	.145	.168	.198	.233	.251	.269	.295	.314	.367	.481

TABLE IB-15
 JOGGLE DEPTH LIMITS
 J-1570
 (SOLUTION TREATED)

GAGE (t)	.016	.020	.025	.032	.040	.050	.063	.071	.080	.090	.100	.125	.187
LENGTH (L)	JOGGLE DEPTH (D)												
.10	.041	.047	.054	.067	.084	.105	.131	.149	.168				
.20	.050	.058	.066	.081	.094	.109	.131	.149	.168	.189	.210	.262	
.30	.058	.066	.078	.092	.106	.123	.143	.157	.172	.189	.210	.262	.382
.40	.063	.074	.086	.102	.117	.136	.158	.173	.187	.201	.218	.262	.382
.50	.068	.079	.093	.109	.126	.146	.172	.188	.202	.217	.235	.273	.382
.60	.073	.084	.099	.116	.135	.156	.183	.196	.214	.232	.250	.290	.382
.70	.077	.089	.104	.121	.142	.164	.194	.203	.225	.242	.264	.304	.392
.80	.079	.093	.108	.127	.149	.171	.200	.214	.235	.251	.273	.318	.405
.90	.080	.097	.111	.132	.154	.178	.205	.225	.244	.263	.282	.332	.422
1.00		.100	.114	.137	.159	.186	.209	.235	.252	.274	.291	.342	.440

TABLE IB-16
 JOGGLE DEPTH LIMITS
 COLUMBIUM (10Mo-10T1)

GAGE (t)	.016	.020	.025	.032	.040	.050	.063	.071	.080	.090	.100	.125	.187
LENGTH (L)	JOGGLE DEPTH (D)												
.10	.028	.033	.038										
.20	.036	.041	.048	.057	.066	.076							
.30	.041	.047	.052	.066	.075	.089	.102	.110					
.40	.045	.052	.060	.072	.083	.097	.114	.121	.133	.143	.155		
.50	.048	.056	.065	.077	.089	.104	.123	.132	.143	.155	.166	.194	
.60		.060	.071	.083	.095	.111	.131	.140	.153	.166	.176	.206	
.70			.074	.087	.100	.118	.137	.148	.161	.175	.186	.218	.281
.80				.091	.105	.123	.143	.155	.168	.184	.195	.229	.293
.90				.095	.109	.127	.148	.161	.176	.189	.203	.240	.304
1.00				.097	.113	.131	.152	.167	.180	.194	.211	.250	.314

TABLE IB-17
 JOGGLE DEPTH LIMITS
 MOLYBDENUM (.5% Ti)
 (HOT ROLLED, STRESS RELIEVED, DE-SCALED SHEET)

GAGE (t)	.016	.020	.025	.032	.040	.050	.063	.071	.080	.090	.100	.125	.187
LENGTH (L)	JOGGLE DEPTH (D)												
.10													
.20	.043												
.30	.049	.058	.067										
.40	.055	.063	.074	.086									
.50	.059	.068	.080	.093	.108								
.60	.063	.072	.085	.100	.115	.134							
.70		.076	.090	.105	.121	.140	.165						
.80		.080	.093	.109	.133	.146	.172	.185					
.90			.096	.114	.145	.153	.178	.192	.212				
1.00			.100	.119	.156	.160	.183	.200	.218	.234			

TABLE IB-18
 JOGGLE DEPTH LIMITS
 TUNGSTEN (PURE)
 TEMPERATURE 1000 °F

GAGE (t)	.016	.020	.025	.032	.040	.050	.063	.071	.080	.090	.100	.125	.187
LENGTH (L)	JOGGLE DEPTH (D)												
.10	.008	.008	.008	.008	.008	.008	.008	.008	.008	.008	.008		
.20	.0106	.0124	.0144	.016	.016	.016	.016	.016	.016	.016	.016	.016	
.30	.012	.0144	.0165	.0192	.0219	.024	.024	.024	.024	.024	.024	.024	.024
.40	.0132	.0152	.0180	.0212	.0244	.028	.032	.032	.032	.032	.032	.032	.032
.50	.0145	.0165	.0190	.0225	.0265	.0305	.0305	.0315	.039	.040	.040	.040	.040
.60	.0156	.0172	.0200	.0234	.0276	.033	.0324	.0354	.039	.042	.0468	.048	.048
.70	.01645	.0185	.0203	.0252	.0294	.036	.035	.0371	.0406	.0434	.0476	.056	.056
.80	.0168	.0195	.0224	.0264	.0304	.037	.036	.0392	.0416	.0456	.0488	.056	.064
.90	.0175	.0207	.0234	.0270	.0315	.036	.0369	.0405	.0441	.047	.0495	.0567	.072
1.00	.0180	.0210	.0247	.0280	.0333	.038	.039	.0410	.046	.0490	.053	.061	.080

SECTION II
FLANGING
A. DIMPLING
B. RUBBER FORMING SHRINK AND
STRETCH FLANGES

DIMPLING

Description of Process

Dimpling is the forming of a depression around a fastener hole in sheet metal by the application of pressure and heat on the material between dies. Dimpling is done so that the conical head of a flush type fastener can be installed. This has been necessary to reduce air drag in modern supersonic aircraft where metal thickness will not permit countersinking.

There are several types of dimpling machines, but for the scope of this program a CP 450 EA Dimpling machine adapted for triple action ram coin dimpling was used. A set of ram coin dimpling dies consists of four parts; the punch (A), die (B), coining ram (C), and pressure pad (D). With the help of Figures II A-1 through II A-4 the mechanical process of dimpling can be understood.

In Figure II A-1 the punch (A) and die (B) are shown in the normal open position. The part to be dimpled has been placed over the pilot on the punch. Note the position of the coining ram face (C) with respect to the die face (B) and the pressure pad (D) is raised around the punch (A).

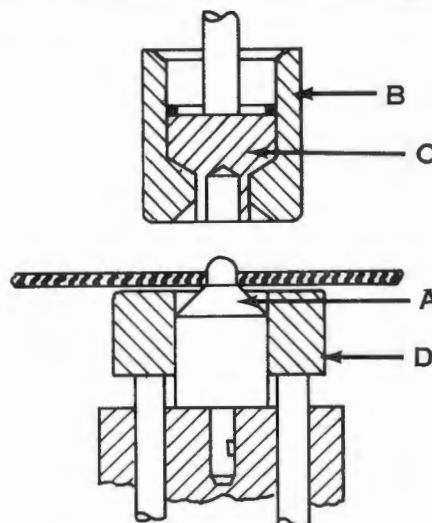

FIGURE II A-1 CROSS SECTION OF RAM COIN DIMPLING

As the die descends, the die and coining ram makes contact with the part as seen below. If dimpling is at elevated temperatures, the die remains in this position for the specified time so that the hot die and coining ram can heat the material immediately surrounding the hole. In order to prevent the metal in the core from stretching and cracking, the ram is forced by pressure against the bottom edge of the cone as the dimple is being formed. This acts as a dam, keeping the depth of the metal uniform throughout the forming operation.

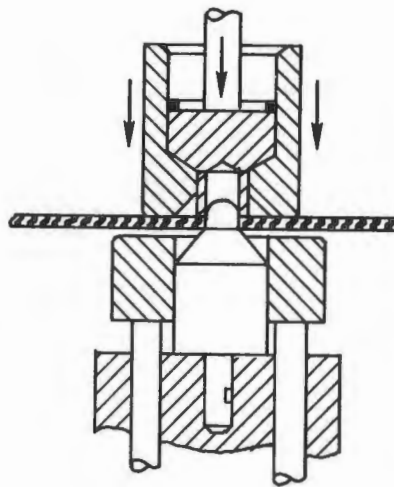

FIGURE II A-2 CROSS SECTION OF RAM COIN DIMPLING

Downward movement of the die assembly will cause the part to contact the pressure pad creating a firm gripping action between the die and pad face around the dimple, thus preventing outward flow of material as the dimple is coined as in Figure II A-3.

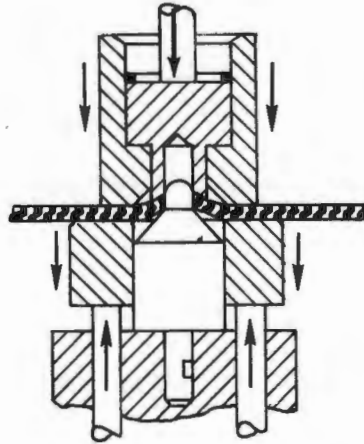

FIGURE II A-3 CROSS SECTION OF RAM COIN DIMPLING

The coining ram controls hole stretch and balances internal strains, eliminating radial and internal shear cracks. The dimple is fully formed in Figure No. II A-4. The confining action of the pad face, die face, and coining ram has forced material into exact configuration with the tool geometry.

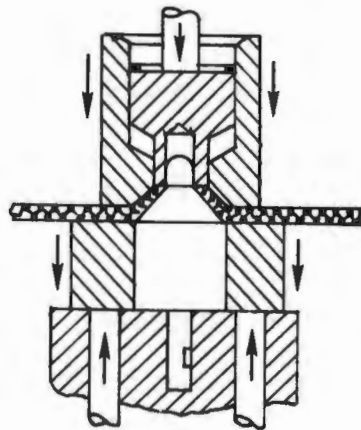

FIGURE II A-4 CROSS SECTION OF RAM COIN DIMPLING

There are four primary forces at work during the forming of a dimple, which tend to make it crack. The first is stretching at the hole in brittle material and in thin gages where there is insufficient material to accommodate the stretch. This causes radial cracks which start at the edge

of the dimple and grow outward. Secondly, the bending over the die cavity sets up tensile stresses in the upper portion of the dimple causing circumferential cracks running around the dimple. The third force is heavy shear loads below the top of the dimple which cause internal circumferential shear cracks. Both types of circumferential failures can be prevented by the proper application of sufficient temperature and pressure. The fourth type of failure is compressive hole cracks caused by excessive coining ram pressure. This type failure is removed by lowering the coining ram pressure.

Some of the machine variables encountered in dimpling are: dimpling pressure, coining pressure, pad pressure, slow form pressure, pad height, post height, die temperature, pad temperature, and the dwell time. By properly varying of machine parameters it is possible to find the optimum setting where a material will dimple best. This optimum setting is where formability tests should be run.

Definition of Part Shape and Geometric Variables

The formability of dimpling is governed by the following geometric variables: radius of the hole R , length of dimple flange h , angle of the dimple α , the material gage t , and the ratio of $\frac{h}{R}$. The parameters are shown in their proper location in the figure below.

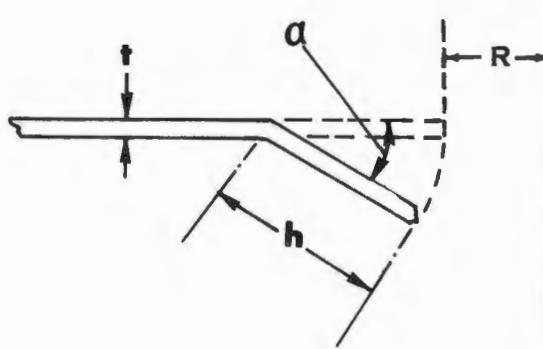

FIGURE II A-5

CROSS SECTION OF DIMPLE SHOWING
GEOMETRIC PARAMETERS

Predictability Equations

The predictability equation for dimpling is:

$$\frac{h}{R} = \frac{(0.444)(\epsilon_{2.0})^{0.253}}{1 - \cos. \alpha} \quad \text{Equation I}$$

To construct the formability curve for dimpling using the predictability equation the following procedure is used. As an example the formability curve for 2024-T3 aluminum will be constructed. To construct this curve it is necessary to obtain the $\epsilon_{2.0}$ value for the material in question. This property for 2024-T3 at room temperature is 17.9%. Using the equation, solve for $\frac{h}{R}$ using an angle α of 40° . This value of $\frac{h}{R}$ is 1.228. Locate and plot this point in the figure below.

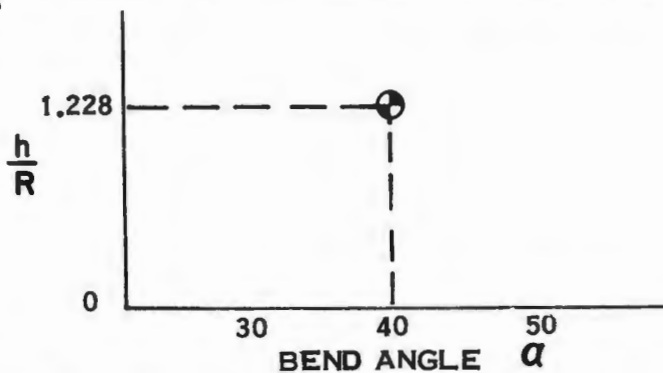

FIGURE II A-6 FORMABILITY GRAPH CONSTRUCTION

Solve the predictability equation for other angles α and construct the predictability curve as shown below.

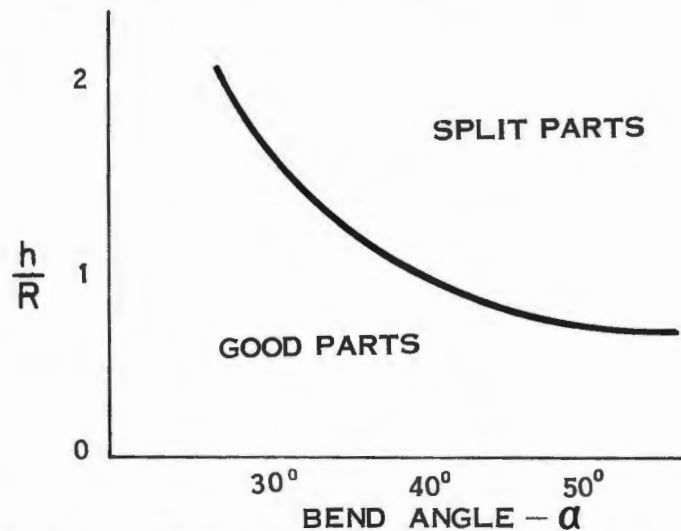

FIGURE II A-7 FORMABILITY CURVE FOR 2024-T3 ALUMINUM

Composite Graphs

The formability curve representing the forming limits for all materials evaluated under this contract is shown in the composite form in Graph II A-1.

Although current design standards are developed around the bend angle of 40° and an approximate ratio of flange width to hole radius h/R , of 1.2, future work might require dimpling for other bend angles.

Better formability is shown to increase as the curves move up and to the right. Some materials, such as HM21XA-T8, are shown to decrease with temperature, while others, such as molybdenum and columbium (10-10), increase with temperature.

COMPOSITE CURVE FOR DIMPLING

GRAPH II A-1

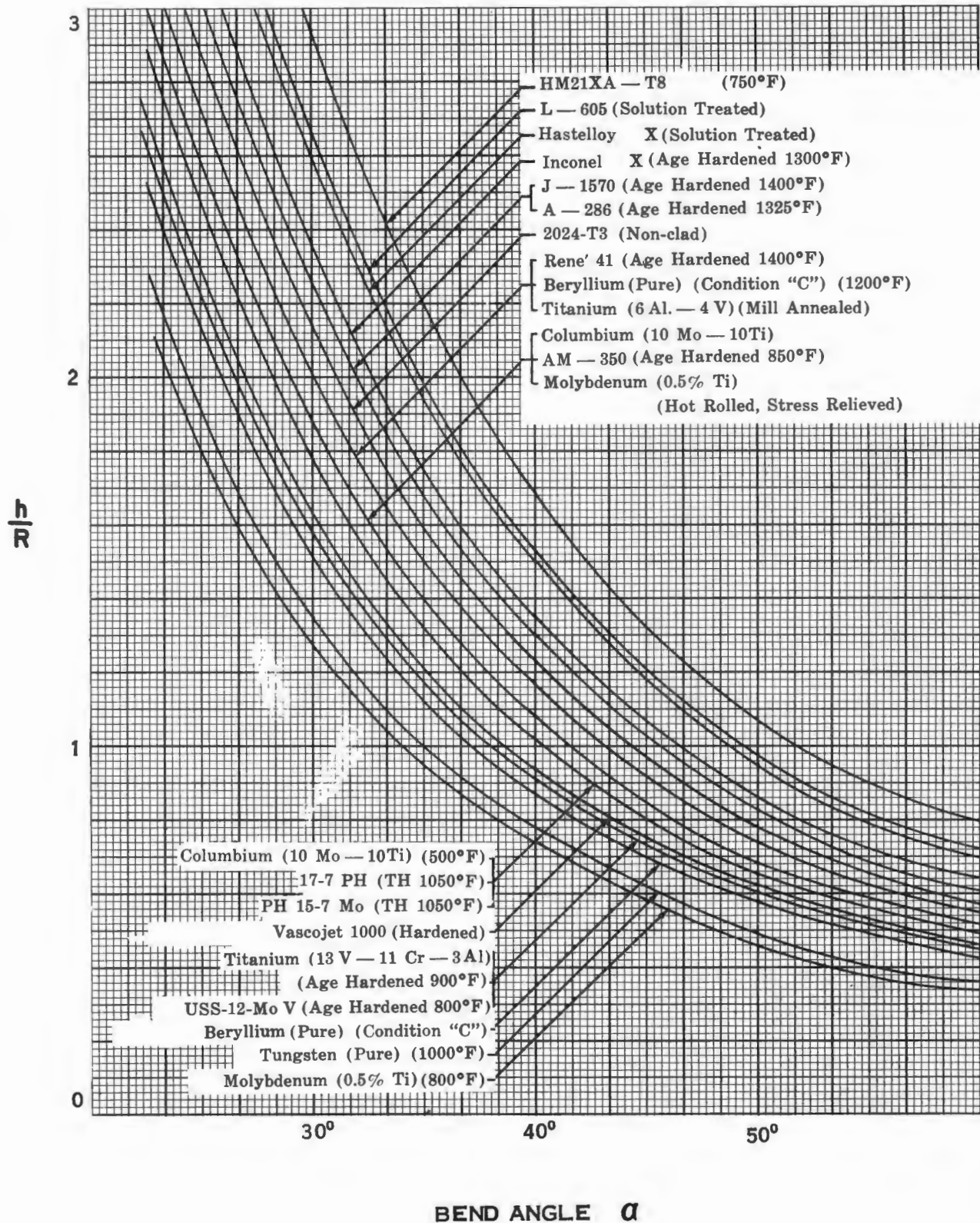

Design Tables

Because current design standards are based on the dimple bend angle of 40° and an approximate h/R ratio of 1.2, a single simple design table can be made for the materials on this contract. This table is shown on the following page as table II A-1.

The table indicates whether the material can be formed to the standard dimple at room temperature. Also shown on the table are the experimental results giving the temperature of the test and whether the standard dimple can be formed at the test temperature. The last column indicates the recommended elevated temperature for fabrication of standard dimples based on published elevated temperature properties.

DIMPLING

Design Table II A-1

Material	Condition	RT	Experimental Tests		Recommended Elev. Temp.
			Temp.	Results	
HM21XA	T8	No	800°	Yes	750°
2024 Aluminum	T3	Yes	RT	Yes	
17-7 Ph	TH 1050	No	RT	No	No
PH 15-7 Mo	TH 1050	No	RT	No	1000°
AM 350	Age Hardened 850°	No	RT	No	1000°
A-286	Age Hardened 1325°	Yes	RT	Yes	1450°
USS-12-MoV	Age Hardened 800°	No	RT	No	No
Titanium (6Al-4V)	Mill Annealed	No	800°	Yes	900°
Titanium (13V-11Cr-3Al)	Age Hardened 900°	No	800°	Yes	900°
Vascojet 1000 (H-11)	Hardened	No	RT	No	1200°
Beryllium (Pure)	Condition "C"*	No	1200°	No	1450°**
Rene '41	Age Hardened 1400°	Yes	RT	No***	Any Temp.
Inconel X	Age Hardened 1300°	Yes	RT	Yes	1800°
Hastelloy X	Solution Treated	Yes	RT	Yes	Any Temp.
L-605	Solution Treated	Yes	RT	Yes	800°
J-1570	Age Hardened 1400°	Yes	RT	Yes	No
Columbium (10Mo-10Ti)	As Received	No	800°	No	1000°
Molybdenum (.5% Ti)	Hot Rolled, Stress Relieved	No	800°	No	1800°
Tungsten (Pure)	As Received	No	800°	No	1200°

* Material is rolled and stress annealed for 10 minutes at 1400°F.

** Form dimple at 2 in./min. strain rate.

*** Insufficient Pressure.

RUBBER FORMING
SHRINK AND STRETCH FLANGES

Description of Process

The process of rubber forming is one of the most common and widely used processes for producing flanged parts of both straight and contoured sections. The use of this process is desirable because tooling is usually simple and most rubber presses have the capacity to form several parts at one time.

The rubber press used to form parts in this contract was a 5,000 ton Lake Erie Hydropress with approximately 1925 PSI rubber pressure capacity. The forming pad of this rubber press is 114" x 48" x 9". A sketch of the rubber press is shown in Figure II B-1.

The process of forming rubber shrink and stretch flanges is relatively simple with few steps involved. The sheet metal blanks are prepared by profile trimming, blanking dies, or by sawing. The use of the saw is usually limited to cases where only a few parts are needed. The prepared blank is placed on a forming tool and is secured on the tool by alignment pins and a cover plate as shown in Figure II B-1. The rubber press is lowered to the part and the part is formed by the rubber pressure acting on the flange.

The major failures that occur in rubber stretch flanges are elastic buckling and splitting. A third limiting factor which is considered in the formability limits is a minimum flange. A minimum flange is encountered when the pressure of the rubber press is insufficient to form the flange to the form block.

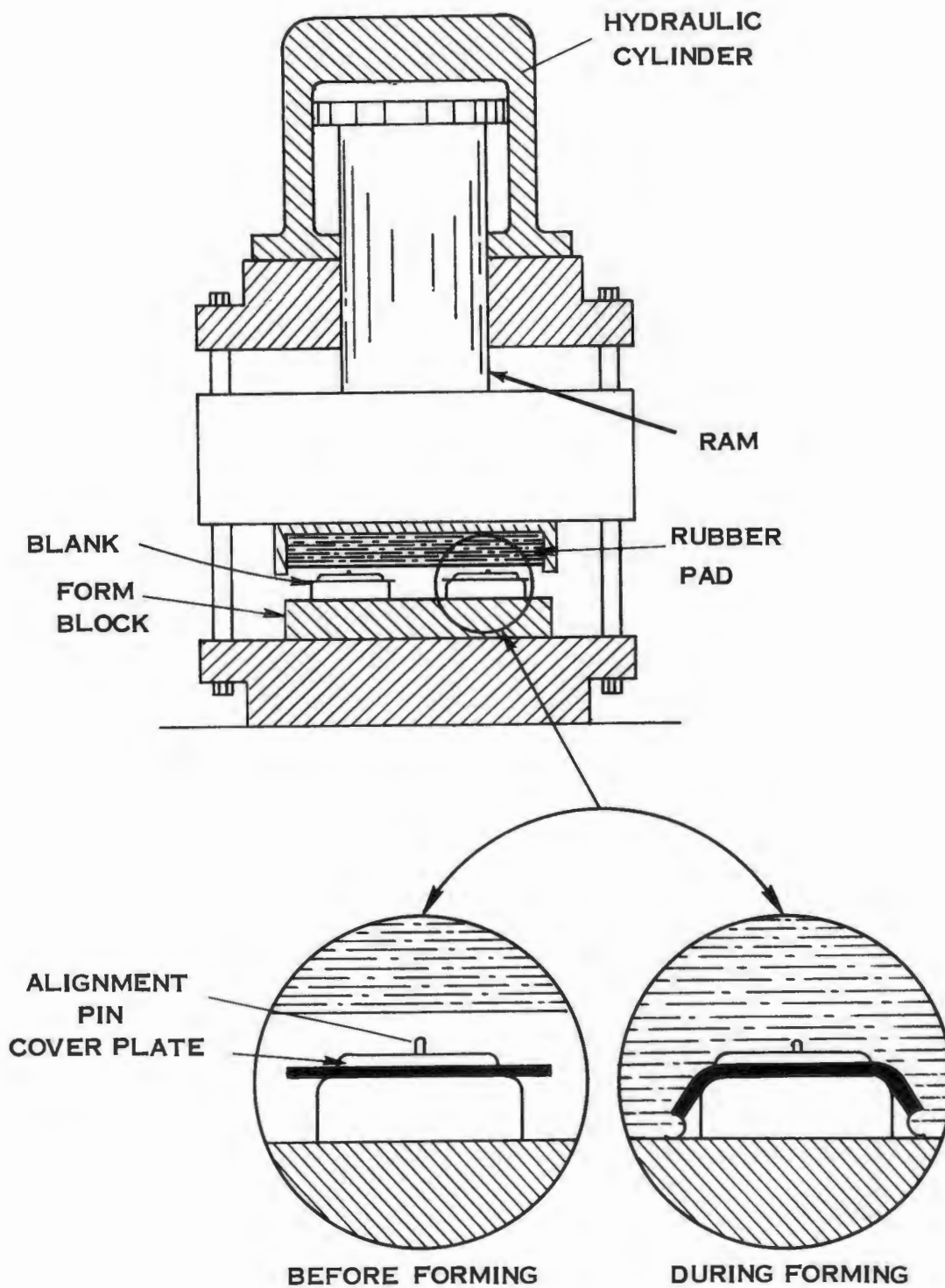

THE GUERIN RUBBER PROCESS
 1925 PSI LAKE ERIE RUBBER PRESS
 FIGURE II B-1

There are other distortions common to stretch flanges but are considered minor since their severity can be minimized or eliminated by subsequent forming operation. These minor failures include springback, crown in the web, shear buckling, and hump.

The major failures that occur in rubber shrink flanges are elastic buckling and plastic buckling. Minimum flange is also encountered in shrink flanges and is considered a limiting forming factor. The minor failures for shrink flanges are the same as previously listed for stretch flanges.

Definition of Part Shape
and Geometric Variables

Rubber stretch flanges may be either along concavely contoured portions or on holes whereas shrink flanges are along convexly contoured portions. The geometric variables, as shown in Figure II B-2, are flange height (h), material thickness (t), part radius (R), web width (w), and segment angle θ .

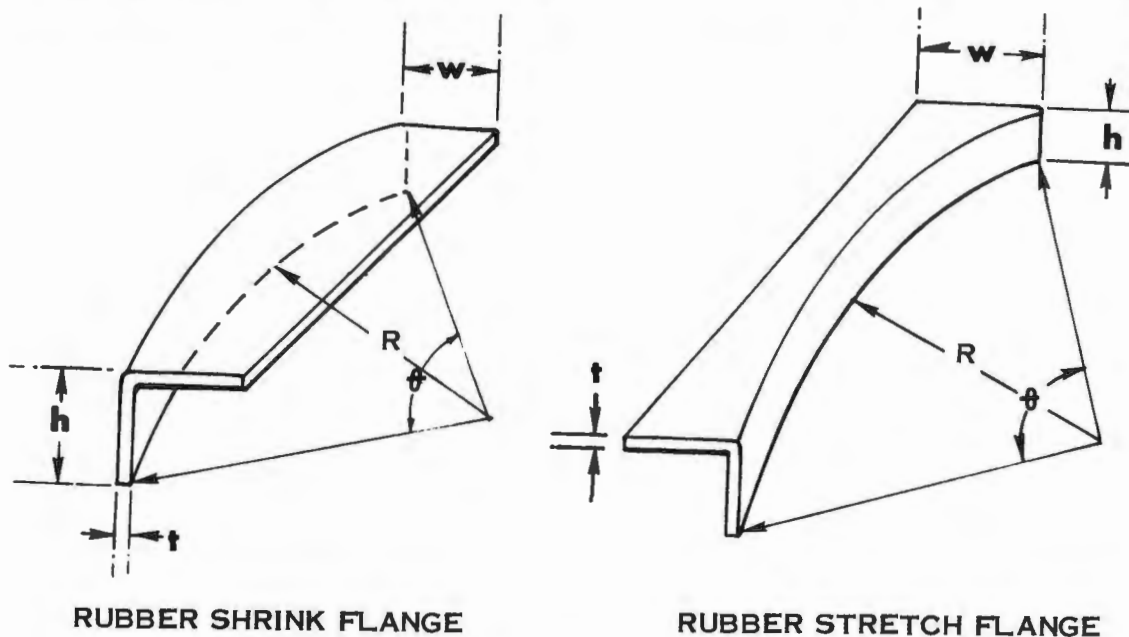

FIGURE II B-2 RUBBER SHRINK AND STRETCH PARTS

The geometric variables that have the greatest influence on the formability limits are flange height, material thickness, and part radius. These three variables are the only ones considered in this contract; however, it has been proved in work done prior to this contract that the buckling and splitting limits will increase with a decrease in segment angle. The extent of increase has not been determined and was not investigated in this contract.

Predictability Equations

The predictability equations for rubber stretch flanges are as follows:

The equation for the splitting limits:

$$\frac{h}{R} = .421 \ln (13.5 \epsilon_{2.0}) \quad \text{Equation I}$$

The equation for the inflection line:

$$\frac{h}{R} = 0.0079 \left(\frac{h}{t} \right)^{0.5} \quad \text{Equation II}$$

The equation for the elastic buckling line:

$$\frac{h}{R} = 0.09 \frac{E}{S_{ty}} \frac{1}{\left(\frac{h}{t} \right)^2} \quad \text{Equation III}$$

The equation for the pressure limit index line:

$$\frac{h}{R} = 102 \left(\frac{h}{t} \right)^{-4.36} \quad \text{Equation IV}$$

The equation for the lower portion of the pressure limit line:

$$\frac{h}{R} = \frac{6.99 \times 10^6}{(S_y)^{4.9}} \left[\frac{h}{t} \right]^{17.0} \quad \text{Equation V}$$

The equation for the pressure limit inflection line:

$$\frac{h}{R} = 0.19 \left(\frac{h}{t} \right)^{-0.235}$$

Equation VI

The equation for the upper portion of the pressure limit line:

$$\frac{h}{R} = \left[\frac{0.19}{[2.72 \times 10^8 (S_y)^{4.9}]^{0.0816}} \right] \left[\frac{h}{t} \right]^{1.17}$$

Equation VII

The predictability equations for rubber shrink flanges are as follows:

The equation for the plastic buckling line:

$$\frac{h}{R} = \frac{1.4}{S_{cy}}$$

Equation VIII

The equation for the elastic buckling line:

$$\frac{h}{R} = \left[\frac{E}{S_{cy}} \right] \frac{0.0225}{\left(\frac{h}{t} \right)^2}$$

Equation IX

The equations for the pressure limits for shrink flanges are identical to the pressure limit equations for stretch flanges except that S_{cy} is substituted for S_{ty} .

The formability equations for rubber stretch and shrink flanges differ slightly but the procedure for constructing formability curves from these equations is basically the same. Due to this similarity, only the use of the rubber stretch equations will be demonstrated.

To demonstrate the use of the basic formability equations a complete formability curve will be constructed for 17-7 PH steel.

The basic material properties that are needed for the construction of the curve are E/S_y , $\epsilon_{2.0}$, and $1/S_y$.

Step I: Using Equation I, $h/R = 4.21 \ln(13.5 \epsilon_{2.0})$, substitute the actual value of $\epsilon_{2.0}$ in the equation and solve for h/R . The value of $\epsilon_{2.0}$ for 17-7 PH is .32. The calculated value for 17-7 PH is $h/R = .62$. Locate $h/R = .62$ on log-log graph paper and construct a horizontal line from this point as shown in the following sketch.

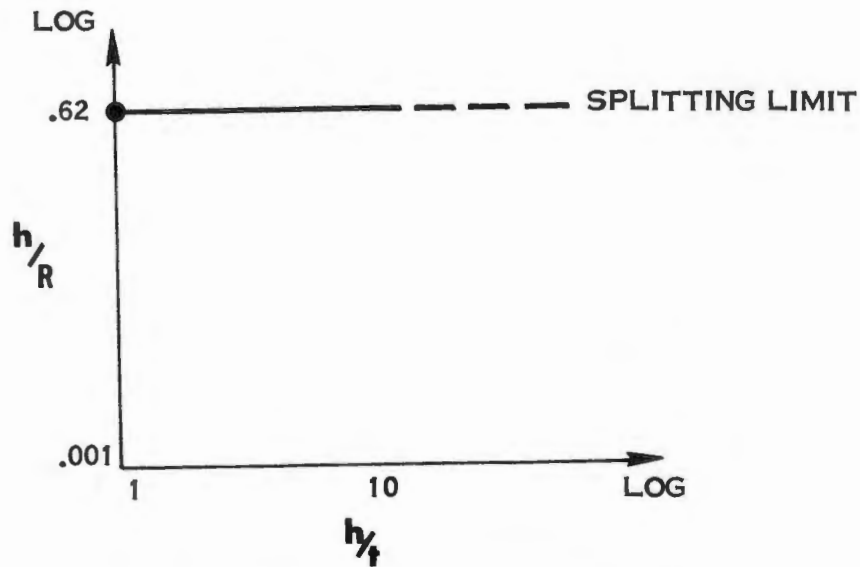

FIGURE II B-3 GRAPH CONSTRUCTION

Step II: Using Equation II, $h/R = .0079 h/t$, construct the inflection line. Locate the point, .0079, on the h/R axis and draw a line with a slope of $1/2$ from this point as shown in the following sketch.

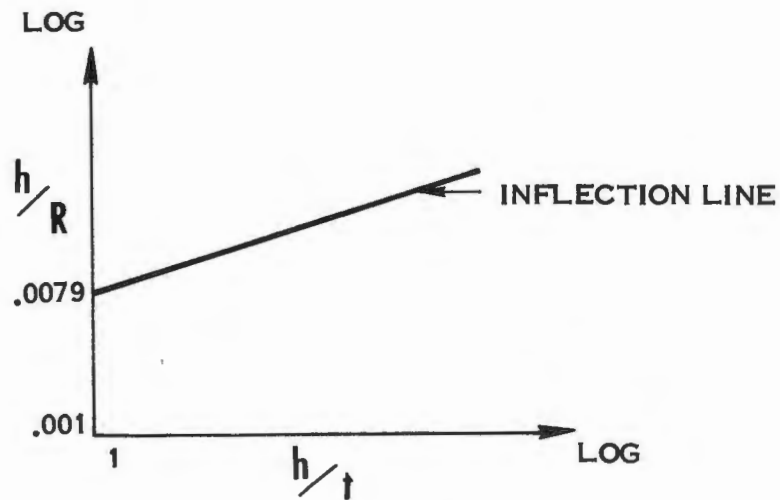

FIGURE II B-4 GRAPH CONSTRUCTION

Step III: Using Equation III, construct the elastic buckling limit.

Substitute the actual value of E/S_{ty} and arbitrarily select a practical value of h/t . Solve for h/R . A value of $h/t = 50$ will be used.

Plot the point $h/R = .0234$ on the $h/t = 50$ line and construct a -2 slope through this point. Extend the line from the h/t axis to the inflection line. Construct a vertical line to the splitting limit line from the point of intersection of the (-2) slope and the inflection line. See the following sketch.

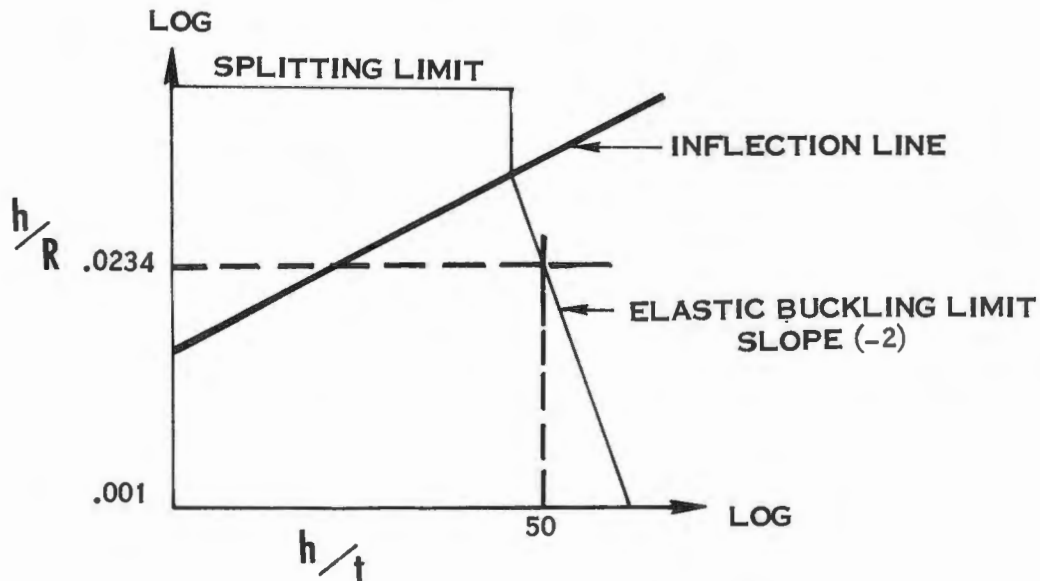

FIGURE II B-5 GRAPH CONSTRUCTION

Step IV: Using Equation IV, $h/R = 102 (h/t)^{-4.36}$, construct the minimum flange (insufficient pressure) index line. Select a practical value of h/t and solve for h/R . Through this point construct a line with a slope of -4.36 . This line is not part of the formability curve but it is necessary for the construction of the pressure limit lines.

Step V: Using Equation V, $h/R = .19 (h/t)^{-.235}$, construct the pressure limit inflection line. From the point, $h/R = .19$ and $h/t = 1$, construct a line with a $-.235$ slope as shown in the following sketch.

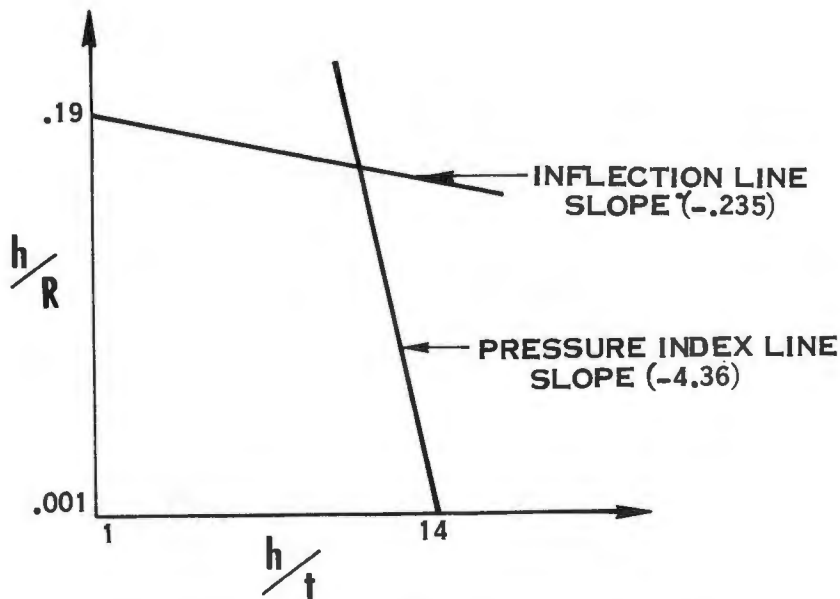

FIGURE II B-6 GRAPH CONSTRUCTION

Step VI: To construct the pressure limit lines obtain the value of $1/S_y \times 10^3$ for the material in question. For 17-7 PH this value is .025. Extend a horizontal line from this point on the h/R axis to the pressure index line. From the intersection of this horizontal line and the pressure index line construct a line with a slope of 17. Extend this line to the pressure limit inflection line. From the intersection of this line and the inflection line construct a line with a slope of 1.17 and extend it to the splitting limit line. See the following sketch.

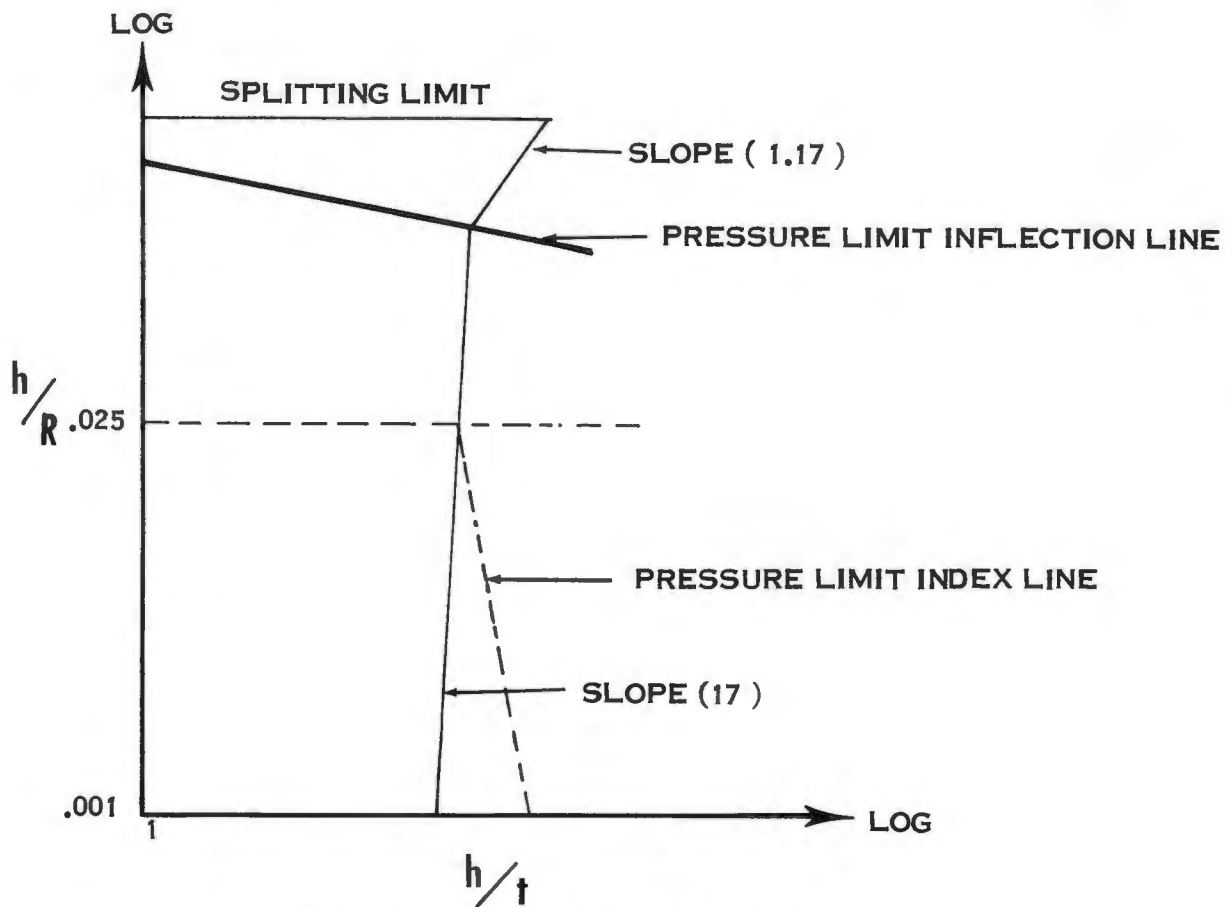

FIGURE II B-7 GRAPH CONSTRUCTION

The intersection of the pressure limit lines at the inflection line, as shown in the above sketch, is a sharp break. Actually, this transition is a gradual curve as shown by the dotted line in the sketch. There is no equation for this portion of the line but the line can be fayed-in by referring to the composite graph presented in the report.

The completion of the foregoing steps will give a complete formability curve for rubber stretch flanges. A complete curve showing areas of good and failed parts is shown in the following sketch.

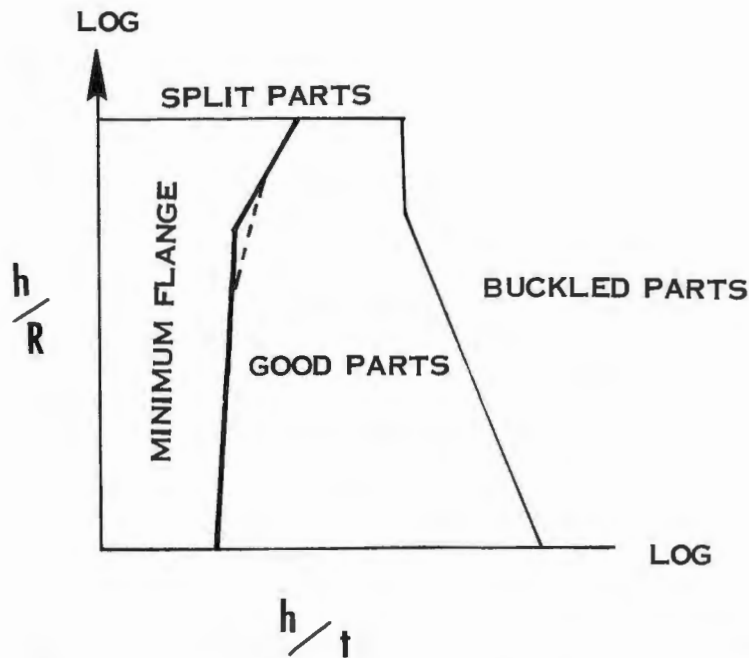

FIGURE II B-8 TYPICAL FORMABILITY CURVE

Composite Graphs

The formability curves representing the forming limits of materials evaluated in this contract are shown in composite form in Graphs II B-1 and II B-2. The composite for rubber stretch flanges is shown in Graph II B-1 and the composite for rubber shrink flanges is shown in Graph II B-2.

All graphs have been presented on a logarithmic basis but a method for plotting design information on Cartesian paper is possible. This type graph will enable the planner or designer to read design limits directly from the graph with no additional calculations necessary. To construct this type graph it is necessary to have previously determined the design limits for the material in question. A plot of maximum possible flange height versus minimum possible contour radius is made for all practical material gages. The design limits for all gages can be plotted on one graph. An example of this type graph using the forming limits of 2024-0 aluminum is shown in Graph II B-3.

The buckling limit lines for rubber stretch flanges represent the point of incipient buckling and should not be considered as the maximum design limits but should be considered as limits where handwork or secondary forming processes will be required. The forming of rubber stretch flanges in this program was done without the aid of overlays, wipers, traps, or other methods of increasing the formability limits. It is possible that the buckling limits can be exceeded where the dimensional tolerances of the part design are such that incipient or slight buckling is of little or no consequence.

There are ways of increasing the splitting and buckling limits of rubber stretch flanges; however, additional tooling is usually required. Splitting limits can be increased in some cases by applying a lubricating film to the surface of the material being formed. This is true

because the lubricant allows the material to elongate or draw more by reducing friction between the material and the rubber of the rubber press. The buckling limits can be extended, in some cases, by trapping or drawing devices. This is accomplished by allowing excess material to bottom out at the base of the forming tool.

The buckling limit lines for rubber shrink flanges, as shown in composite Graph II B-2, are based on buckles that are approximately .07" in depth in the plastic buckling region and .035" in depth in the elastic buckling region. It is necessary to extend the design limits for shrink flanges due to the very low limits of initial and incipient buckling. The buckling limits are extended to include practical flange heights keeping within the practical areas of handwork. The extension of the buckling limit lines for shrink flanges is demonstrated in the following schematic. Area A includes parts where buckle depth = 0. Area B₁ includes parts with buckle depths ranging from 0" to .07" and area B₂ includes parts with buckle depths ranging from 0" to .035".

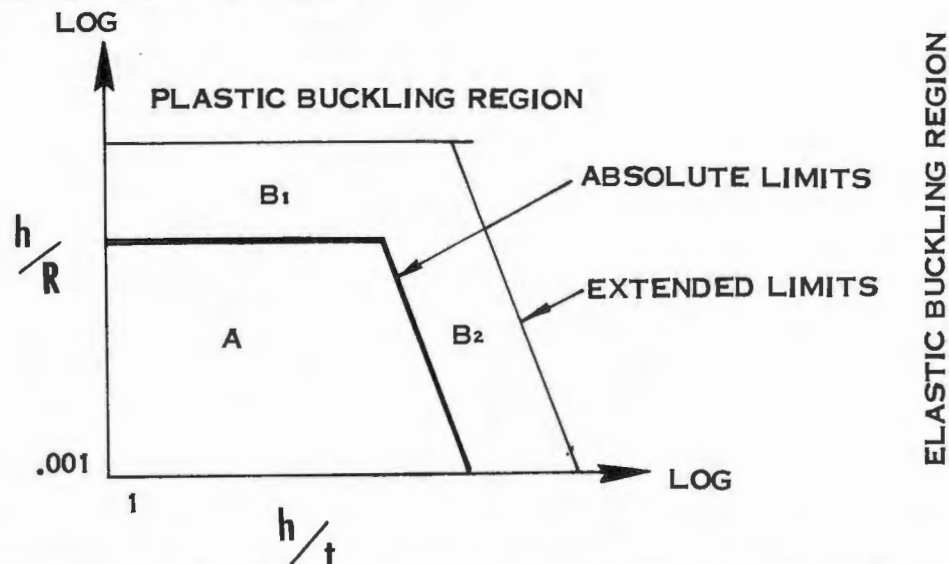

FIGURE II B-9 ABSOLUTE AND EXTENDED RUBBER SHRINK FORMABILITY LIMITS

The formability limits for rubber stretch flanges are based on the minimum physical properties of each material. The physical properties of any material will vary from sheet to sheet and for this reason, it is important to consider the possible formability range for any material. An example is shown in the following sketch.

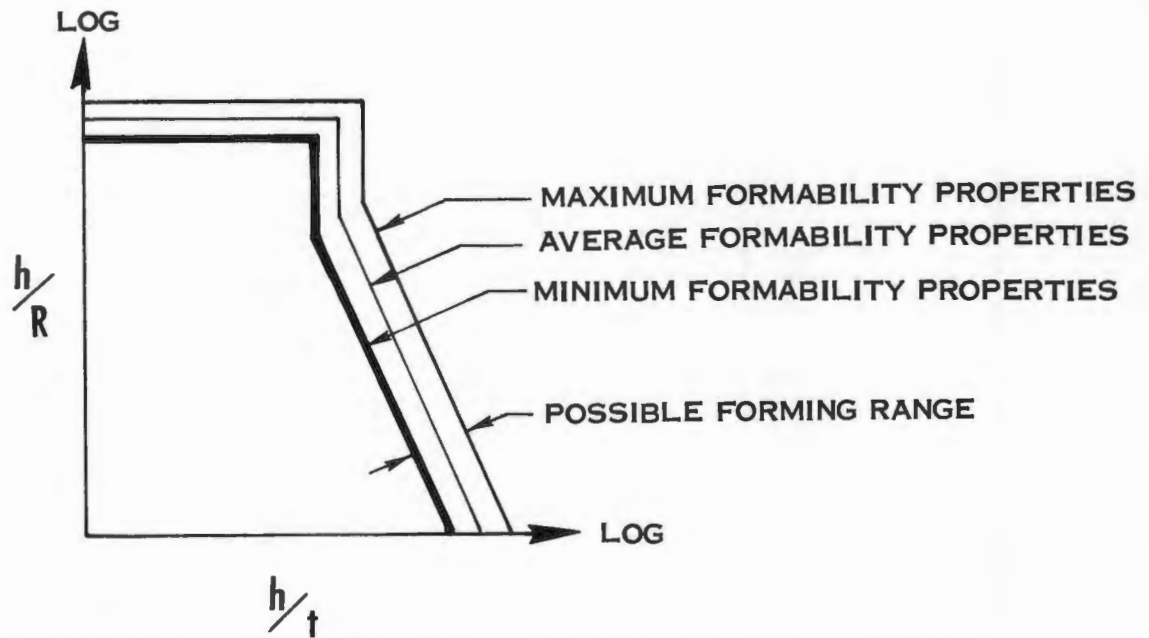
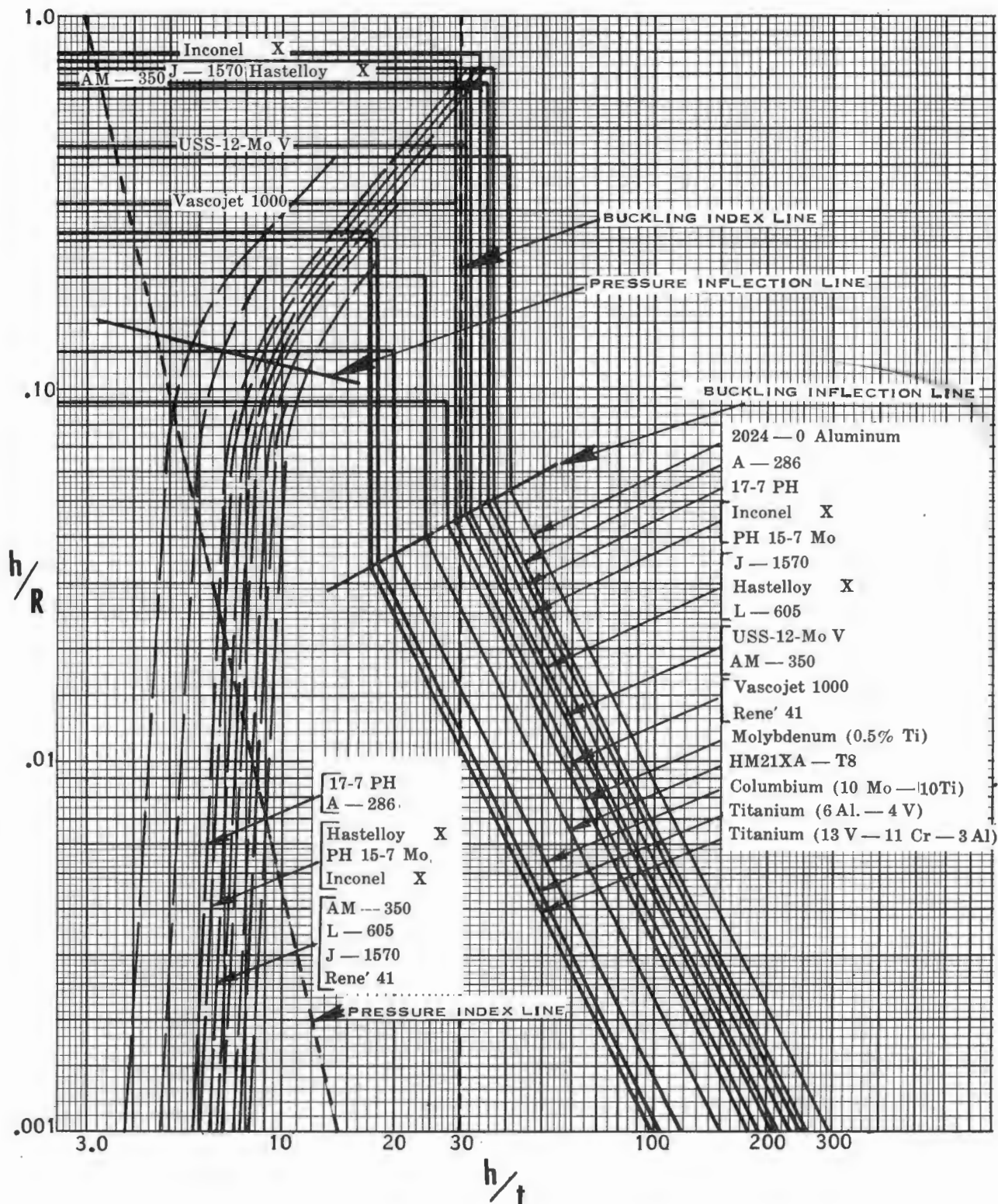

FIGURE II B-10 POSSIBLE RANGE IN FORMABILITY CURVES

GRAPH II B-1

COMPOSITE GRAPH FOR RUBBER STRETCH FLANGES



GRAPH II B-2
COMPOSITE GRAPH FOR RUBBER SHRINK FLANGES

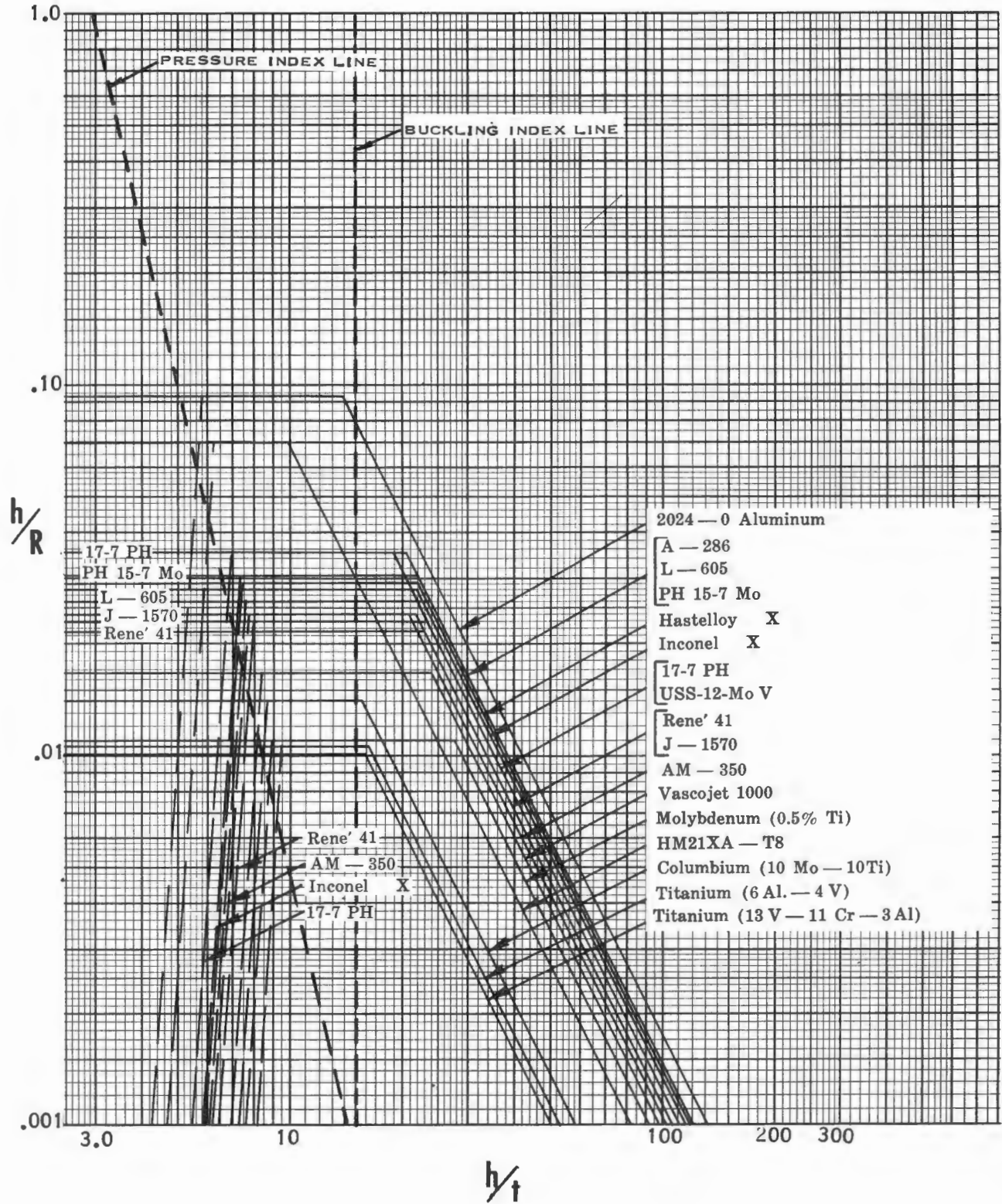

GRAPH II B-3
 ALTERNATE METHOD OF PLOTTING
 RUBBER STRETCH FORMABILITY LIMITS
 2024-0 ALUMINUM

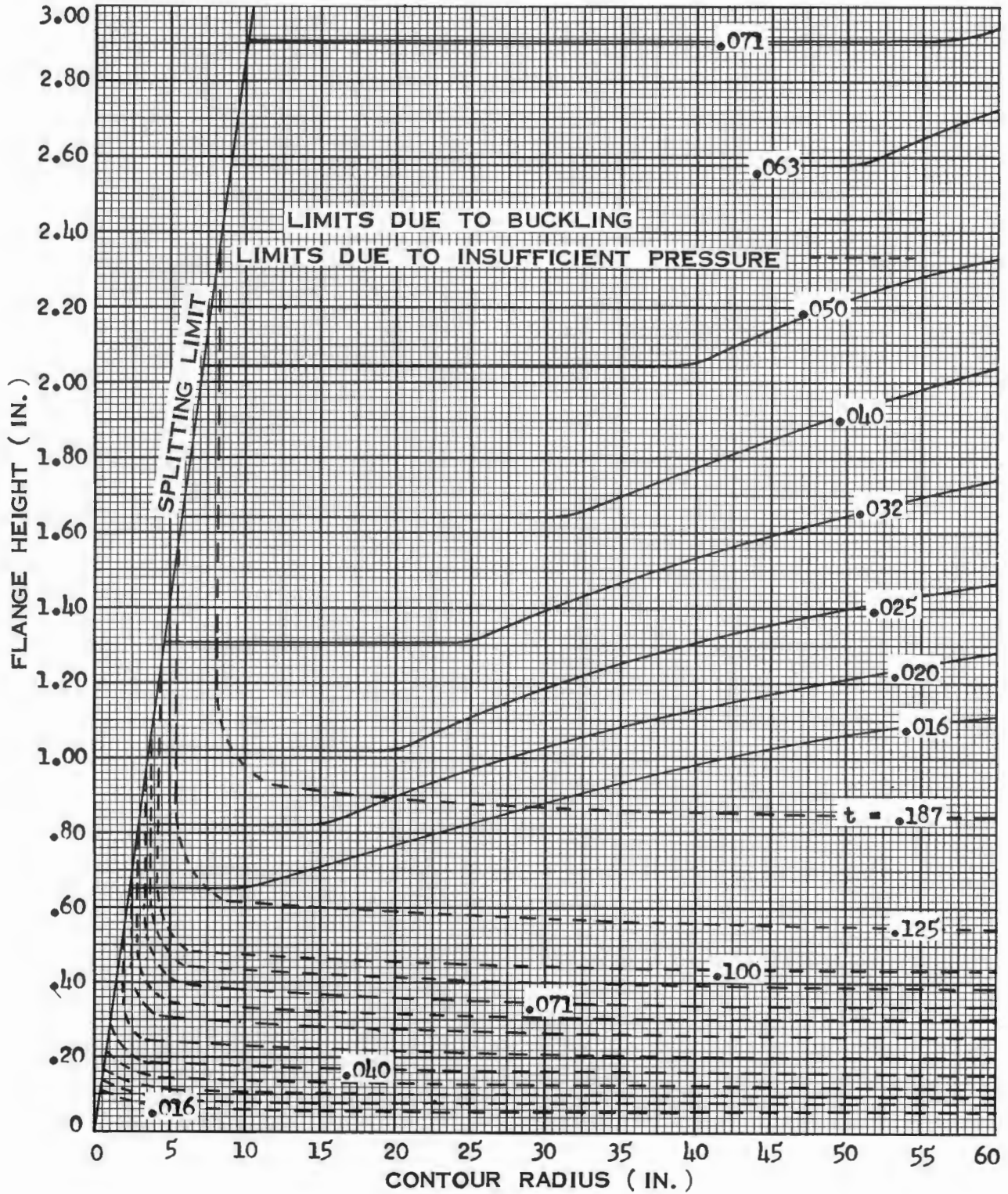

Design Tables

The design tables for rubber stretch flanges are shown in Tables II B-1 through II B-17 and the design tables for rubber shrink flanges are shown in Tables II B-18 through II B-34.

The design tables are so constructed that the maximum and minimum flange height and minimum contour radius can be read directly for any practical material gage. Design limits for all materials evaluated in this contract, with the exception of tungsten and beryllium, are shown in the design tables. Beryllium and tungsten were excluded due to their very brittle nature at the maximum possible forming temperatures of the rubber press.

The open spaces that appear in the design tables for rubber stretch flanges are vacant because the combination of geometric part variables makes forming impossible due to insufficient pressure.

Buckling and splitting failures are separated by a heavy line on the design tables. Design limits listed above and to the right of the heavy line are maximum due to splitting. Limits below and to the left of the line are maximum due to buckling.

The open spaces that appear in the design tables for rubber shrink flanges represent areas that are outside the forming area due to buckling or insufficient pressure.

TABLE II B-1
RUBBER FORMING LIMITS
STRETCH FLANGES
HM21XA-T8 (MAGNESIUM THORIUM)

Contour Radius R	Material Thickness (t)												
	.016	.020	.025	.032	.040	.050	.063	.071	.080	.090	.100	.125	.187
	Maximum and Minimum Flange Height Limits (h)												
5	.38	.48	.60	.77	.84	.84	.85	.85	.84	.76			
	.09	.11	.14	.19	.24	.30	.38	.43	.54	.68			
10	.38	.48	.60	.77	.96	1.20	1.51	1.70	1.64	1.68	1.70	1.63	1.68
	.09	.11	.14	.18	.23	.29	.37	.41	.47	.54	.60	.76	1.68
15	.45	.52	.60	.77	.96	1.20	1.51	1.70	1.92	2.16	2.40	2.44	2.47
	.08	.11	.13	.17	.22	.28	.36	.40	.46	.52	.58	.74	1.14
20	.50	.57	.66	.78	.96	1.20	1.51	1.70	1.92	2.16	2.40	3.00	3.31
	.08	.10	.13	.17	.22	.28	.35	.39	.45	.51	.58	.73	1.12
25	.53	.61	.71	.84	.96	1.20	1.51	1.70	1.92	2.16	2.40	3.00	4.11
	.08	.10	.13	.17	.21	.27	.35	.39	.45	.51	.57	.72	1.10
30	.56	.65	.76	.89	1.03	1.20	1.51	1.70	1.92	2.16	2.40	3.00	4.49
	.08	.10	.13	.17	.21	.27	.34	.39	.44	.50	.56	.71	1.08
35	.59	.69	.80	.94	1.09	1.26	1.51	1.70	1.92	2.16	2.40	3.00	4.49
	.08	.10	.13	.17	.21	.27	.34	.39	.44	.50	.56	.71	1.08
40	.62	.72	.84	.99	1.14	1.32	1.54	1.70	1.92	2.16	2.40	3.00	4.49
	.08	.10	.13	.17	.21	.27	.34	.38	.44	.50	.56	.70	1.07
45	.64	.75	.86	1.01	1.18	1.37	1.60	1.70	1.92	2.16	2.40	3.00	4.49
	.08	.10	.13	.16	.21	.26	.33	.38	.43	.49	.55	.69	1.05
50	.66	.77	.90	1.56	1.22	1.42	1.65	1.79	1.92	2.16	2.40	3.00	4.49
	.08	.10	.13	.16	.21	.26	.33	.38	.43	.49	.54	.69	1.05
55	.70	.80	.93	1.90	1.26	1.47	1.76	1.86	2.00	2.16	2.40	3.00	4.49
	.08	.10	.12	.16	.20	.26	.33	.38	.43	.48	.54	.69	1.05
60	.70	.83	.95	1.12	1.32	1.50	1.78	1.92	2.08	2.25	2.40	3.00	4.49
	.08	.10	.12	.16	.20	.26	.33	.37	.42	.48	.54	.68	1.05
65	.74	.85	.99	1.15	1.34	1.57	1.83	1.97	2.12	2.30	2.45	3.00	4.49
	.08	.10	.12	.16	.20	.26	.33	.37	.42	.48	.54	.68	1.04
70	.75	.94	1.00	1.18	1.38	1.60	1.87	2.01	2.18	2.37	2.53	3.00	4.49
	.08	.10	.12	.16	.20	.25	.33	.37	.42	.47	.53	.68	1.04

ASD TR 61-191(II)

II-28

TABLE II B-2
RUBBER FORMING LIMITS
STRETCH FLANGES
2024-O ALUMINUM

ASD TR 61-191(II)

II-29

Contour Radius R	Material Thickness (t)												
	.016	.020	.025	.032	.040	.050	.063	.071	.080	.090	.100	.125	.137
	Maximum and Minimum Flange Height Limits (h)												
5	.65	.82	1.02	1.31	1.44	1.45	1.48	1.49	1.48	1.482	1.48		
	.07	.09	.11	.15	.190	.240	.31	.35	.40	.466	.54		
10	.65	.82	1.02	1.31	1.64	2.05	2.58	2.91	2.88	2.965	2.90	2.840	2.90
	.07	.08	.11	.14	.181	.230	.292	.33	.38	.432	.48	.62	.99
15	.69	.82	1.02	1.31	1.64	2.05	2.58	2.91	3.28	3.69	4.10	4.37	4.34
	.06	.08	.10	.139	.176	.223	.286	.32	.368	.42	.47	.60	.91
20	.77	.89	1.02	1.31	1.64	2.05	2.58	2.91	3.28	3.69	4.10	5.125	5.8
	.06	.08	.10	.137	.17	.220	.281	.32	.364	.41	.46	.58	.89
25	.83	.97	1.11	1.31	1.64	2.05	2.58	2.91	3.28	3.69	4.10	5.125	7.29
	.06	.08	.10	.13	.17	.218	.278	.31	.360	.40	.46	.58	.89
30	.88	1.02	1.19	1.39	1.64	2.05	2.58	2.91	3.28	3.69	4.10	5.125	7.67
	.06	.08	.102	.133	.16	.212	.272	.31	.352	.39	.44	.57	.88
35	.92	1.07	1.25	1.47	1.7	2.05	2.58	2.91	3.28	3.69	4.10	5.125	7.6
	.06	.08	.100	.131	.167	.211	.270	.30	.349	.39	.44	.56	.86
40	.96	1.13	1.31	1.52	1.77	2.05	2.58	2.91	3.28	3.69	4.10	5.12	7.67
	.06	.079	.100	.13	.16	.210	.268	.30	.348	.39	.44	.56	.86
45	1.00	1.16	1.35	1.58	1.84	2.15	2.58	2.91	3.28	3.69	4.10	5.12	7.67
	.06	.08	.099	.13	.164	.209	.264	.30	.342	.38	.43	.55	.85
50	1.04	1.20	1.40	1.63	1.92	2.20	2.58	2.91	3.28	3.69	4.10	5.12	7.67
	.06	.08	.099	.13	.164	.21	.264	.30	.342	.38	.43	.55	.85
55	1.10	1.25	1.44	1.69	1.98	2.29	2.64	2.91	3.28	3.69	4.10	5.12	7.670
	.06	.08	.099	.13	.164	.21	.264	.30	.342	.38	.43	.55	.85
60	1.09	1.28	1.47	1.74	2.04	2.3	2.74	2.94	3.28	3.69	4.10	5.12	7.670
	.06	.076	.097	.12	.160	.202	.26	.29	.336	.37	.42	.54	.83
65	1.13	1.32	1.52	1.87	2.10	2.45	2.83	3.05	3.320	3.69	4.10	5.12	7.670
	-	.076	.09	.12	.16	.20	.26	.29	.336	.37	.42	.54	.83
70	1.16	1.35	1.56	1.85	2.14	2.50	2.90	3.12	3.400	3.69	4.10	5.12	7.670
		.07	.097	.12	.16	.20	.26	.29	.336	.37	.42	.54	.83

TABLE II B-3
RUBBER FORMING LIMITS
STRETCH FLANGES
17-7 PH (CONDITION A)

Contour Radius R	Material Thickness (t)												
	.016	.020	.025	.032	.040	.050	.063	.071	.080	.090	.100	.125	.187
	Maximum and Minimum Flange Height Limits (h)												
5	.56	.71	.88	1.13	1.42	1.77	2.01	1.845					
	.10	.13	.17	.24	.28	.36	.47	.582					
10	.56	.71	.88	1.13	1.42	1.77	2.23	2.520	2.84	3.19	3.55	3.87	
	.10	.13	.165	.21	.27	.34	.44	.497	.56	.63	.71	.97	
15	.61	.71	.88	1.13	1.42	1.77	2.23	2.520	2.84	3.19	3.55	4.44	5.98
	.12	.12	.162	.21	.26	.33	.43	.483	.55	.63	.70	.88	1.44
20	.78	.79	.91	1.13	1.42	1.77	2.23	2.520	2.84	3.19	3.55	4.44	6.64
	.09	.12	.16	.20	.26	.33	.419	.476	.54	.61	.69	.87	1.32
25	.72	.85	.98	1.15	1.42	1.77	2.23	2.520	2.84	3.19	3.55	4.44	6.64
	.09	.12	.16	.20	.26	.33	.42	.474	.54	.61	.69	.87	1.32
30	.77	.90	1.05	1.21	1.42	1.77	2.25	2.520	2.84	3.19	3.55	4.44	6.64
	.09	.12	.15	.20	.26	.32	.41	.472	.53	.60	.67	.85	1.31
35	.80	.94	1.11	1.28	1.48	1.77	2.23	2.520	2.84	3.19	3.55	4.44	6.64
	.09	.124	.15	.20	.26	.32	.41	.472	.53	.60	.67	.85	1.31
40	.84	.99	1.15	1.34	1.56	1.80	2.23	2.520	2.84	3.19	3.55	4.44	6.64
	.09	.12	.15	.20	.25	.32	.40	.461	.52	.59	.66	.84	1.29
45	.87	1.02	1.17	1.39	1.62	1.87	2.23	2.520	2.84	3.19	3.55	4.44	6.64
	.09	.12	.15	.19	.25	.32	.41	.461	.52	.58	.66	.83	1.27
50	.91	1.05	1.22	1.50	1.68	1.95	2.27	2.520	2.84	3.19	3.55	4.44	6.64
	.09	.12	.15	.19	.25	.32	.41	.461	.52	.58	.660	.83	1.27
55	.94	1.10	1.26	1.50	1.74	2.02	2.36	2.555	2.84	3.19	3.55	4.44	6.64
	.09	.12	.15	.19	.24	.31	.40	.454	.51	.58	.65	.82	1.27
60	.98	1.13	1.3	1.54	1.80	2.0	2.4	2.63	2.84	3.19	3.55	4.44	6.64
	.09	.12	.15	.19	.24	.31	.40	.454	.51	.58	.65	.82	1.26
65	1.00	1.16	1.3	1.60	1.84	2.15	2.52	2.70	2.92	3.19	3.55	4.44	6.64
	.09	.11	.15	.19	.24	.315	.400	.454	.51	.58	.650	.81	1.26
70	1.02	1.19	1.39	1.62	1.90	2.20	2.55	2.77	3.00	3.06	3.55	4.44	6.64
	.09	.11	.15	.19	.24	.31	.39	.444	.51	.57	.64	.81	1.25

ASD TR 61-191(II)

II-30

TABLE II B-4
RUBBER FORMING LIMITS
STRETCH FLANGES
PH 15-7 Mo (CONDITION A)

ASD TR 61-191(II)

II-31

Contour Radius R	Material Thickness (t)												
	.016	.020	.025	.032	.040	.050	.063	.071	.080	.090	.100	.125	.157
	Maximum and Minimum Flange Height Limits (h)												
5	.54	.68	.85	1.09	1.36	1.70	2.00	1.42					
	.11	.14	.18	.23	.30	.38	.52	.64					
10	.54	.68	.85	1.09	1.36	1.70	2.14	2.42	2.72	3.06	3.40	3.82	
	.11	.14	.17	.23	.29	.36	.46	.52	.59	.67	.76	1.00	
15	.59	.69	.85	1.09	1.36	1.70	2.14	2.42	2.72	3.06	3.40	4.25	5.89
	.11	.13	.17	.22	.28	.35	.45	.51	.58	.65	.73	.93	1.55
20	.65	.76	.89	1.09	1.36	1.70	2.14	2.42	2.72	3.06	3.40	4.25	6.35
	.10	.13	.17	.22	.27	.35	.44	.50	.57	.64	.72	.91	1.40
25	.70	.82	.95	1.12	1.36	1.70	2.14	2.42	2.72	3.06	3.40	4.25	6.35
	.10	.13	.17	.21	.27	.34	.44	.50	.56	.64	.72	.91	1.38
30	.74	.87	1.01	1.18	1.36	1.70	2.14	2.42	2.72	3.06	3.40	4.25	6.35
	.10	.13	.17	.21	.27	.34	.43	.49	.56	.63	.71	.90	1.37
35	.78	.91	1.06	1.25	1.44	1.70	2.14	2.42	2.72	3.06	3.40	4.25	6.35
	.10	.13	.16	.21	.27	.34	.43	.49	.55	.63	.70	.89	1.36
40	.82	.96	1.11	1.30	1.52	1.75	2.14	2.42	2.72	3.06	3.40	4.25	6.35
	.10	.13	.16	.21	.27	.34	.43	.48	.55	.62	.70	.88	1.35
45	.86	1.00	1.15	1.34	1.59	1.82	2.14	2.42	2.72	3.06	3.40	4.25	6.35
	.10	.13	.16	.21	.26	.34	.43	.48	.54	.62	.69	.88	1.34
50	.88	1.03	1.19	1.41	1.62	1.90	2.20	2.42	2.72	3.06	3.40	4.25	6.35
	.10	.13	.16	.21	.26	.33	.42	.48		.62	.69	.88	1.34
55	.92	1.07	1.24	1.45	1.69	1.95	2.28	2.48	2.72	3.06	3.40	4.25	6.35
	.10	.13	.16	.21	.26	.33	.42	.48	.54	.62	.69	.88	1.34
60	.94	1.10	1.26	1.49	1.74	2.00	2.36	2.55	2.72	3.06	3.40	4.25	6.35
	.10	.13	.16	.21	.26	.33	.42	.47	.54	.61	.68	.86	1.32
65	.98	1.13	1.31	1.54	1.80	2.08	2.43	2.63	2.84	3.06	3.40	4.25	6.35
	.10	.12	.16	.20	.26	.33	.42	.47	.54	.61	.68	.86	1.32
70	1.00	1.16	1.34	1.58	1.84	2.12	2.48	2.70	2.88	3.15	3.40	4.25	6.35
	.10	.12	.16	.20	.26	.33	.41	.47	.53	.60	.67	.86	1.31

TABLE II B-5
RUBBER FORMING LIMITS
STRETCH FLANGES
AM-350 (ANNEALED)

Contour Radius R	Material Thickness (t)												
	.016	.020	.025	.032	.040	.050	.063	.071	.080	.090	.100	.125	.157
	Maximum and Minimum Flange Height Limits (h)												
5	.49	.61	.77	.98	1.23	1.53	1.93						
	.12	.15	.19	.25	.32	.42	.60						
10	.49	.61	.77	.98	1.23	1.53	1.93	2.18	2.46	2.76	3.07	2.68	
	.12	.15	.18	.24	.30	.38	.49	.56	.63	.72	.82	1.19	
15	.54	.63	.87	.98	1.23	1.53	1.93	2.18	2.46	2.76	3.07	3.84	4.86
	.11	.14	.18	.24	.30	.38	.48	.54	.62	.70	.79	1.00	1.78
20	.60	.70	.90	.98	1.23	1.53	1.93	2.18	2.46	2.76	3.07	3.84	5.75
	.11	.14	.18	.23	.30	.37	.47	.54	.61	.69	.78	.99	1.53
25	.65	.75	.92	1.04	1.23	1.53	1.93	2.18	2.46	2.76	3.07	3.84	5.75
	.11	.14	.18	.23	.29	.37	.47	.53	.60	.68	.76	.96	1.48
30	.69	.80	.97	1.09	1.26	1.53	1.93	2.18	2.46	2.76	3.07	3.84	5.75
	.11	.14	.18	.23	.29	.37	.47	.53	.60	.67	.75	.96	1.46
35	.72	.84	1.02	1.14	1.32	1.53	1.93	2.18	2.46	2.76	3.07	3.84	5.75
	.11	.14	.18	.23	.29	.36	.46	.53	.60	.67	.75	.95	1.45
40	.75	.88	1.05	1.20	1.38	1.62	1.93	2.18	2.46	2.76	3.07	3.84	5.75
	.11	.14	.17	.22	.28	.36	.45	.52	.59	.67	.75	.94	1.44
45	.78	.91	1.09	1.25	1.44	1.68	1.95	2.18	2.46	2.76	3.07	3.84	5.75
	.11	.14	.17	.22	.28	.36	.45	.51	.58	.67	.74	.94	1.42
50	.81	.94	1.11	1.28	1.50	1.73	2.05	2.18	2.46	2.76	3.07	3.84	5.78
	.11	.13	.17	.22	.28	.35	.45	.51	.58	.67	.74	.94	1.42
55	.85	.98	1.12	1.34	1.56	1.80	2.11	2.27	2.46	2.76	3.07	3.84	5.78
	.11	.13	.17	.22	.28	.35	.45	.51	.58	.66	.74	.94	1.42
60	.87	1.02	1.17	1.37	1.60	1.88	2.17	2.38	2.56	2.76	3.07	3.84	5.78
	.10	.13	.17	.22	.28	.35	.44	.50	.57	.65	.73	.93	1.40
65	.90	1.04	1.20	1.41	1.64	1.90	2.20	2.41	2.60	2.84	3.07	3.84	5.78
	.10	.13	.17	.22	.28	.35	.44	.50	.57	.65	.72	.93	1.40
70	.92	1.06	1.22	1.46	1.70	1.95	2.27	2.48	2.68	2.88	3.07	3.84	5.78
	.10	.13	.17	.22	.28	.35	.44	.50	.57	.64	.72	.93	1.40

TABLE II B-6
RUBBER FORMING LIMITS
STRETCH FLANGES
A-286 (SOLUTION TREATED)

Contour Radius R	Material Thickness (t)												
	.016	.020	.025	.032	.040	.050	.063	.071	.080	.090	.100	.125	.187
	Maximum and Minimum Flange Height Limits (h)												
5	.58	.72	.90	1.15	1.44	1.80	2.21	1.77					
	.11	.13	.17	.22	.28	.36	.48	.58					
10	.58	.72	.90	1.15	1.44	1.80	2.27	2.56	2.88	3.24	3.60	4.12	
	.10	.13	.17	.21	.27	.34	.44	.50	.56	.64	.72	.96	
15	.64	.74	.90	1.15	1.44	1.80	2.27	2.56	2.88	3.24	3.60	4.5	6.45
	.10	.13	.16	.21	.26	.33	.43	.48	.55	.63	.70	.88	1.44
20	.70	.82	.95	1.15	1.44	1.80	2.27	2.56	2.88	3.24	3.60	4.5	6.73
	.10	.13	.16	.21	.26	.33	.43	.48	.55	.63	.70	.88	1.35
25	.75	.88	1.02	1.18	1.44	1.80	2.27	2.56	2.88	3.24	3.60	4.5	6.73
	.10	.12	.16	.21	.26	.33	.42	.47	.54	.61	.68	.86	1.31
30	.80	.92	1.07	1.26	1.44	1.80	2.27	2.56	2.88	3.24	3.60	4.5	6.73
	.10	.12	.16	.21	.26	.32	.41	.47	.53	.60	.68	.86	1.31
35	.83	.96	1.13	1.31	1.52	1.80	2.27	2.56	2.88	3.24	3.60	4.5	6.73
	.10	.12	.16	.21	.26	.32	.41	.47	.53	.60	.67	.85	1.30
40	.88	1.02	1.20	1.41	1.60	1.88	2.27	2.56	2.88	3.24	3.60	4.5	6.73
	.09	.12	.16	.20	.25	.32	.41	.46	.52	.59	.67	.84	1.29
45	.90	1.06	1.23	1.44	1.68	1.95	2.27	2.56	2.88	3.24	3.60	4.5	6.73
	.09	.12	.15	.20	.25	.32	.41	.46	.52	.59	.66	.84	1.27
50	.94	1.08	1.28	1.49	1.74	2.00	2.33	2.56	2.88	3.24	3.60	4.5	6.73
	.09	.12	.15	.20	.25	.32	.40	.46	.52	.59	.66	.84	1.27
55	.98	1.13	1.30	1.54	1.80	2.08	2.43	2.63	2.88	3.24	3.60	4.5	6.73
	.09	.12	.15	.20	.25	.32	.40	.46	.52	.59	.66	.83	1.27
60	1.00	1.17	1.35	1.60	1.84	2.17	2.52	2.70	2.88	3.24	3.60	4.5	6.73
	.09	.12	.15	.20	.25	.31	.40	.46	.52	.59	.65	.83	1.26
65	1.04	1.20	1.40	1.66	1.92	2.25	2.58	2.80	3.04	3.24	3.60	4.5	6.73
	.09	.12	.15	.19	.25	.31	.40	.46	.51	.59	.65	.83	1.26
70	1.06	1.23	1.43	1.68	1.96	2.25	2.65	2.84	3.12	3.33	3.60	4.5	6.73
	.09	.12	.15	.19	.24	.31	.40	.45	.51	.58	.65	.82	1.25

ASD TR 61-191(II)

II-33

TABLE II B-7
RUBBER FORMING LIMITS
STRETCH FLANGES
USS-12-MoV (ANNEALED)

Contour Radius R	Material Thickness (t)												
	.016	.020	.025	.032	.040	.050	.063	.071	.080	.090	.100	.125	.187
	Maximum and Minimum Flange Height Limits (h)												
5	.49	.61	.77	.98	1.23	1.53	1.01						
	.13	.16	.20	.26	.34	.44	1.01						
10	.49	.61	.81	.98	1.23	1.53	1.93	2.18	2.46	2.76	3.07		
	.12	.15	.19	.25	.32	.40	.51	.58	.66	.75	.86		
15	.54	.63	.87	.98	1.23	1.53	1.93	2.18	2.46	2.76	3.07	3.84	2.99
	.12	.15	.19	.25	.31	.40	.50	.57	.65	.73	.82	1.05	2.99
20	.60	.70	.90	.98	1.23	1.53	1.93	2.18	2.46	2.76	3.07	3.84	5.75
	.12	.15	.19	.24	.30	.39	.49	.56	.64	.72	.80	1.01	1.57
25	.65	.75	.92	1.04	1.23	1.53	1.93	2.18	2.46	2.76	3.07	3.84	5.75
	.11	.15	.19	.24	.30	.37	.49	.56	.63	.72	.80	1.01	1.55
30	.69	.80	.97	1.09	1.26	1.53	1.93	2.18	2.46	2.76	3.07	3.84	5.75
	.11	.14	.18	.24	.30	.37	.48	.55	.63	.71	.89	1.00	1.53
35	.72	.84	1.02	1.14	1.32	1.53	1.93	2.18	2.46	2.76	3.07	3.84	5.75
	.11	.14	.18	.23	.30	.37	.48	.54	.62	.70	.78	1.00	1.51
40	.75	.88	1.05	1.20	1.38	1.62	1.93	2.18	2.46	2.76	3.07	3.84	5.75
	.11	.14	.18	.23	.29	.37	.47	.54	.61	.69	.77	.99	1.50
45	.78	.91	1.09	1.25	1.44	1.68	1.95	2.18	2.46	2.76	3.07	3.84	5.75
	.11	.14	.18	.23	.29	.37	.47	.54	.61	.69	.77	.97	1.50
50	.81	.94	1.11	1.28	1.50	1.73	2.05	2.18	2.46	2.76	3.07	3.84	5.75
	.11	.14	.18	.23	.29	.37	.47	.53	.60	.68	.76	.97	1.49
55	.85	.98	1.12	1.34	1.56	1.80	2.11	2.27	2.46	2.76	3.07	3.84	5.75
	.11	.14	.18	.23	.29	.37	.47	.53	.60	.68	.76	.96	1.49
60	.87	1.02	1.17	1.37	1.60	1.88	2.17	2.38	2.56	2.76	3.07	3.84	5.75
	.11	.14	.18	.23	.29	.37	.46	.53	.60	.68	.76	.96	1.49
65	.90	1.04	1.20	1.41	1.64	1.90	2.20	2.41	2.60	2.84	3.07	3.84	5.75
	.11	.14	.17	.23	.29	.36	.46	.53	.60	.68	.76	.96	1.48
70	.92	1.06	1.22	1.46	1.70	1.95	2.27	2.48	2.68	2.88	3.07	3.84	5.75
	.11	.14	.17	.23	.28	.36	.46	.53	.60	.68	.76	.96	1.48

ASD TR 61-191(II)

TI-34

TABLE II B-8
RUBBER FORMING LIMITS
STRETCH FLANGES
TITANIUM (6 Al-4V)(MILL ANNEALED)

Contour Radius R	Material Thickness (t)												
	.016	.020	.025	.032	.040	.050	.063	.071	.080	.090	.100	.125	.157
	Maximum and Minimum Flange Height Limits (h)												
5	.29	.36	.45	.58	.72	.90							
	.16	.20	.25	.32	.44	.90							
10	.30	.36	.45	.58	.72	.90	1.13	1.28	1.44	1.62	1.80		
	.15	.19	.24	.31	.40	.52	.64	.74	.89	1.04	1.80		
15	.35	.40	.47	.58	.72	.90	1.13	1.28	1.44	1.62	1.80	2.25	
	.15	.18	.24	.30	.39	.49	.62	.71	.81	.92	1.03	1.41	
20	.38	.45	.51	.61	.72	.90	1.13	1.28	1.44	1.62	1.80	2.25	3.37
	.14	.18	.23	.30	.38	.48	.62	.70	.79	.90	1.01	1.27	2.37
25	.41	.48	.55	.65	.75	.90	1.13	1.28	1.44	1.62	1.80	2.25	3.37
	.14	.18	.23	.30	.37	.47	.61	.69	.78	.89	1.00	1.26	2.02
30	.44	.51	.59	.69	.80	.93	1.13	1.28	1.44	1.62	1.80	2.25	3.37
	.14	.18	.23	.29	.37	.47	.60	.68	.78	.88	.98	1.25	1.91
35	.46	.54	.62	.73	.85	.98	1.13	1.28	1.44	1.62	1.80	2.25	3.37
	.14	.18	.22	.29	.37	.46	.59	.67	.77	.87	.97	1.24	1.91
40	.48	.56	.65	.77	.88	1.04	1.20	1.30	1.44	1.62	1.80	2.25	3.37
	.14	.17	.22	.29	.36	.46	.59	.67	.76	.86	.96	1.23	1.87
45	.50	.58	.67	.79	.92	1.06	1.25	1.33	1.46	1.62	1.80	2.25	3.37
	.14	.17	.22	.29	.36	.46	.59	.67	.76	.86	.96	1.21	1.86
50	.52	.60	.70	.83	.95	1.10	1.27	1.39	1.51	1.62	1.80	2.25	3.37
	.14	.17	.22	.29	.36	.46	.58	.66	.75	.85	.95	1.21	1.85
55	.54	.62	.72	.86	.99	1.14	1.32	1.43	1.55	1.69	1.80	2.25	3.37
	.14	.17	.22	.28	.36	.45	.58	.66	.75	.85	.95	1.20	1.85
60	.55	.64	.75	.87	1.02	1.18	1.39	1.49	1.62	1.75	1.88	2.25	3.37
	.13	.17	.22	.28	.36	.45	.57	.65	.74	.84	.94	1.19	1.83
65	.57	.66	.76	.90	1.04	1.20	1.40	1.51	1.65	1.78	1.90	2.25	3.37
	.13	.17	.22	.28	.35	.45	.57	.65	.74	.83	.93	1.19	1.81
70	.58	.68	.78	.92	1.07	1.25	1.45	1.56	1.70	1.84	1.96	2.29	3.37
	.13	.17	.22	.28	.35	.45	.57	.65	.74	.83	.93	1.18	1.81

ASD TR 61-191(II)

II-35

TABLE II B-9
RUBBER FORMING LIMITS
STRETCH FLANGES
TITANIUM (13V-11Cr-3 Al)(SOLUTION TREATED)

Contour Radius R	Material Thickness (t)												
	.016	.020	.025	.032	.040	.050	.063	.071	.080	.090	.100	.125	.187
	Maximum and Minimum Flange Height Limits (h)												
5	.28	.34	.43	.55	.69								
	.16	.20	.25	.33	.43								
10	.29	.34	.43	.55	.69	.86	1.08	1.22	1.38	1.55	1.57		
	.15	.19	.24	.31	.40	.50	.65	.73	.87	1.05	1.57		
15	.34	.39	.45	.55	.69	.86	1.08	1.22	1.38	1.55	1.72	2.15	
	.15	.19	.24	.30	.39	.49	.63	.71	.81	.92	1.03	1.40	
20	.37	.43	.50	.58	.69	.86	1.08	1.22	1.38	1.55	1.72	2.15	3.22
	.14	.18	.23	.30	.38	.48	.61	.70	.79	.90	1.00	1.27	2.32
25	.40	.46	.53	.64	.73	.86	1.08	1.22	1.38	1.55	1.72	2.15	3.22
	.14	.18	.23	.30	.38	.48	.61	.69	.78	.89	1.00	1.26	2.00
30	.42	.49	.57	.67	.78	.90	1.08	1.22	1.38	1.55	1.72	2.15	3.22
	.14	.18	.23	.29	.37	.47	.60	.69	.78	.88	.99	1.25	1.93
35	.44	.52	.60	.70	.81	.95	1.10	1.22	1.38	1.55	1.72	2.15	3.22
	.14	.18	.22	.29	.37	.47	.60	.67	.77	.87	.97	1.23	1.89
40	.46	.54	.63	.74	.86	1.00	1.17	1.27	1.38	1.55	1.72	2.15	3.22
	.14	.18	.22	.29	.37	.46	.59	.67	.76	.86	.96	1.23	1.89
45	.48	.56	.65	.77	.90	1.03	1.21	1.30	1.42	1.55	1.72	2.15	3.22
	.14	.17	.22	.29	.36	.46	.59	.67	.76	.85	.96	1.23	1.87
50	.50	.58	.67	.80	.92	1.08	1.23	1.35	1.44	1.57	1.72	2.15	3.22
	.13	.17	.22	.28	.36	.45	.58	.65	.74	.84	.95	1.20	1.83
55	.52	.60	.70	.83	.95	1.11	1.29	1.39	1.50	1.63	1.74	2.15	3.22
	.13	.17	.22	.28	.36	.45	.57	.65	.74	.83	.94	1.19	1.83
60	.53	.62	.71	.85	.97	1.15	1.32	1.43	1.56	1.69	1.82	2.15	3.22
	.13	.17	.21	.28	.35	.45	.57	.65	.74	.83	.94	1.19	1.82
65	.54	.64	.73	.87	1.00	1.18	1.37	1.48	1.60	1.73	1.85	2.15	3.22
	.13	.17	.21	.28	.35	.45	.57	.65	.74	.83	.94	1.19	1.82
70	.56	.65	.75	.89	1.04	1.20	1.40	1.50	1.64	1.78	1.90	2.22	3.22
	.13	.17	.21	.28	.35	.44	.56	.64	.73	.82	.92	1.17	1.79

ASD TR 61-191(II)

II-36

TABLE II B-10
RUBBER FORMING LIMITS
STRETCH FLANGES
VASCOJET 1000 (H-11) (ANNEALED)

Contour Radius R	Material Thickness (t)												
	.016	.020	.025	.032	.040	.050	.063	.071	.080	.090	.100	.125	.157
	Maximum and Minimum Flange Height Limits (h)												
5	.46	.58	.73	.93	1.16	1.17							
	.13	.16	.21	.27	.35	.47							
10	.46	.58	.73	.93	1.16	1.45	1.93	2.06	2.32	2.37	2.35		
	.13	.16	.20	.26	.33	.42	.54	.60	.70	.81	.94		
15	.51	.60	.73	.93	1.16	1.45	1.83	2.06	2.32	2.61	2.90	3.46	
	.12	.16	.20	.25	.32	.41	.52	.59	.67	.76	.85	1.11	
20	.57	.66	.76	.93	1.16	1.45	1.83	2.06	2.32	2.61	2.90	3.62	4.68
	.12	.15	.19	.25	.32	.40	.51	.58	.66	.75	.84	1.06	1.73
25	.61	.71	.82	.98	1.16	1.45	1.83	2.06	2.32	2.61	2.90	3.62	5.42
	.12	.15	.19	.25	.32	.40	.50	.57	.65	.73	.82	1.05	1.60
30	.65	.76	.87	1.02	1.20	1.45	1.83	2.06	2.32	2.61	2.90	3.62	5.42
	.12	.15	.19	.25	.31	.40	.50	.57	.64	.73	.82	1.04	1.59
35	.68	.79	.93	1.09	1.26	1.45	1.83	2.06	2.32	2.61	2.90	3.62	5.42
	.12	.15	.19	.24	.31	.39	.50	.56	.64	.72	.81	1.03	1.57
40	.71	.84	.96	1.14	1.32	1.52	1.83	2.06	2.32	2.61	2.90	3.62	5.42
	.12	.15	.19	.24	.30	.39	.49	.56	.64	.72	.81	1.02	1.57
45	.74	.86	1.00	1.17	1.36	1.60	1.86	2.06	2.32	2.61	2.90	3.62	5.42
	.12	.15	.19	.24	.30	.39	.49	.56	.63	.72	.80	1.01	1.54
50	.77	.89	1.04	1.22	1.42	1.65	1.92	2.06	2.32	2.61	2.90	3.62	5.42
	.12	.15	.19	.24	.30	.39	.49	.56	.63	.71	.80	1.01	1.54
55	.80	.92	1.07	1.26	1.46	1.70	1.98	2.13	2.32	2.61	2.90	3.62	5.42
	.12	.15	.19	.24	.30	.38	.49	.55	.63	.71	.80	1.00	1.53
60	.82	.96	1.10	1.30	1.50	1.75	2.05	2.20	2.40	2.61	2.90	3.62	5.42
	.11	.15	.19	.24	.30	.38	.49	.55	.62		.79	1.00	1.51
65	.85	.98	1.14	1.34	1.56	1.80	2.11	2.27	2.48	2.67	2.90	3.62	5.42
	.11	.14	.18	.24	.30	.38	.49	.55	.62	.70	.79	1.00	1.51
70	.87	1.01	1.16	1.38	1.60	1.85	2.14	2.34	2.52	2.74	2.95	3.62	5.42
	.11	.14	.18	.23	.30	.37	.48	.54	.61	.69	.78	.99	1.51

TABLE II B-11
RUBBER FORMING LIMITS
STRETCH FLANGES
RENE 41 (SOLUTION TREATED)

Contour Radius R	Material Thickness (t)												
	.016	.020	.025	.032	.040	.050	.063	.071	.080	.090	.100	.125	.187
	Maximum and Minimum Flange Height Limits (h)												
5	.46	.58	.73	.93	1.16	1.45	.95						
	.13	.16	.20	.26	.33	.44	.95						
10	.46	.58	.73	.93	1.16	1.45	1.83	2.06	2.32	2.61	2.90		
	.12	.15	.19	.25	.32	.40	.52	.59	.67	.76	.87		
15	.51	.60	.73	.93	1.16	1.45	1.83	2.06	2.32	2.61	2.90	3.62	
	.12	.15	.19	.25	.31	.40	.50	.57	.65	.73	.82	1.05	
20	.57	.66	.76	.93	1.16	1.45	1.83	2.06	2.32	2.61	2.90	3.62	5.42
	.12	.15	.19	.24	.31	.39	.50	.56	.64	.72	.81	1.06	1.61
25	.61	.71	.82	.98	1.16	1.45	1.83	2.06	2.32	2.61	2.90	3.62	5.42
	.12	.15	.18	.24	.30	.38	.49	.56	.63	.72	.80	1.02	1.56
30	.65	.76	.87	1.02	1.20	1.45	1.83	2.06	2.32	2.61	2.90	3.62	5.42
	.11	.14	.18	.24	.30	.38	.49	.55	.63	.71	.79	1.00	1.54
35	.68	.79	.91	1.08	1.26	1.45	1.83	2.06	2.32	2.61	2.90	3.62	5.42
	.11	.14	.18	.23	.30	.37	.48	.55	.62	.70	.78	1.00	1.52
40	.71	.84	.96	1.14	1.32	1.52	1.83	2.06	2.32	2.61	2.90	3.62	5.42
	.11	.14	.18	.23	.29	.37	.48	.54	.62	.70	.78	.99	1.51
45	.74	.85	1.00	1.17	1.36	1.60	1.86	2.06	2.32	2.61	2.90	3.62	5.42
	.11	.14	.18	.23	2.9	.37	.48	.54	.61	.69	.77	.98	1.50
50	.77	.90	1.04	1.22	1.40	1.65	1.92	2.06	2.32	2.61	2.90	3.62	5.42
	.11	.14	.18	.23	.29	.37	.47	.54	.61	.69	.77	.98	1.50
55	.80	.92	1.06	1.26	1.46	1.70	1.95	2.13	2.32	2.61	2.90	3.62	5.42
	.11	.14	.18	.23	.29	.36	.47	.53	.60	.68	.76	.97	1.49
60	.82	.96	1.10	1.30	1.50	1.75	2.05	2.20	2.40	2.61	2.90	3.62	5.42
	.11	.14	.18	.23	.29	.36	.46	.53	.60	.68	.76	.97	1.48
65	.85	.98	1.14	1.34	1.54	1.80	2.11	2.27	2.44	2.67	2.90	3.62	5.42
	.11	.14	.17	.23	.29	.36	.46	.53	.60	.67	.76	.96	1.47
70	.86	1.01	1.16	1.38	1.60	1.85	2.14	2.34	2.52	2.74	2.95	3.62	5.42
	.11	.14	.17	.22	.28	.36	.46	.52	.59	.67	.75	.96	1.47

ASD TR 61-191(II)

II-38

TABLE II B-12
RUBBER FORMING LIMITS
STRETCH FLANGES
INCONEL X (C.R. ANNEALED)

ASD TR 61-191(II)

II-39

Contour Radius R	Material Thickness (t)												
	.016	.020	.025	.032	.040	.050	.063	.071	.080	.090	.100	.125	.187
	Maximum and Minimum Flange Height Limits (h)												
5	.54	.68	.85	1.09	1.36	1.70	2.14						
	.11	.14	.18	.24	.30	.39	.57						
10	.54	.68	.85	1.09	1.36	1.70	2.14	2.42	2.72	3.06	3.40	4.25	
	.11	.14	.18	.23	.29	.36	.47	.52	.60	.68	.77	1.12	
15	.59	.69	.85	1.09	1.36	1.70	2.14	2.42	2.72	3.06	3.40	4.25	6.35
	.11	.13	.17	.22	.28	.35	.45	.51	.59	.67	.75	.94	1.66
20	.61	.77	.89	1.09	1.36	1.70	2.14	2.42	2.72	3.06	3.40	4.25	6.35
	.11	.13	.17	.22	.28	.35	.45	.51	.58	.66	.74	.93	1.44
25	.70	.82	.95	1.12	1.36	1.70	2.14	2.42	2.72	3.06	3.40	4.25	6.35
	.11	.13	.17	.22	.28	.35	.45	.50	.57	.65	.73	.92	1.40
30	.74	.87	1.01	1.18	1.36	1.70	2.14	2.42	2.72	3.06	3.40	4.25	6.35
	.10	.13	.17	.22	.27	.35	.45	.50	.56	.64	.73	.91	1.40
35	.78	.91	1.05	1.25	1.44	1.70	2.14	2.42	2.72	3.06	3.40	4.25	6.35
	.10	.13	.16	.21	.27	.34	.44	.50	.56	.63	.71	.90	1.38
40	.82	.96	1.11	1.30	1.52	1.75	2.14	2.42	2.72	3.06	3.40	4.25	6.35
	.10	.13	.16	.21	.27	.34	.43	.49	.56	.63	.70	.89	1.36
45	.85	.99	1.15	1.34	1.59	1.82	2.14	2.42	2.72	3.06	3.40	4.25	6.35
	.10	.13	.16	.21	.26	.34	.43	.49	.55	.63	.70	.89	1.36
50	.88	1.03	1.19	1.41	1.62	1.90	2.20	2.42	2.72	3.06	3.40	4.25	6.35
	.10	.13	.16	.21	.26	.34	.43	.49	.55	.63	.70	.88	1.35
55	.92	1.07	1.23	1.45	1.68	1.95	2.27	2.48	2.72	3.06	3.40	4.25	6.35
	.10	.13	.16	.21	.26	.34	.43	.48	.55	.63	.69	.88	1.35
60	.94	1.10	1.27	1.49	1.74	2.00	2.36	2.55	2.76	3.06	3.40	4.25	6.35
	.10	.13	.16	.21	.26	.33	.42	.48	.54	.62	.69	.88	1.34
65	.96	1.12	1.3	1.54	1.78	2.08	2.43	2.63	2.84	3.06	3.40	4.25	6.35
	.10	.13	.16	.21	.26	.33	.42	.48	.54	.61	.68	.87	1.33
70	1.00	1.16	1.34	1.58	1.83	2.12	2.48	2.66	2.88	3.15	3.40	4.25	6.35
	.10	.13	.16	.21	.26	.33	.42	.47	.54	.61	.68	.87	1.33

TABLE II B-13
RUBBER FORMING LIMITS
STRETCH FLANGES
HASTELLOY X (SOLUTION TREATED)

ASD TR 61-191(II)

II-40

Contour Radius R	Material Thickness (t)												
	.016	.020	.025	.032	.040	.050	.063	.071	.080	.090	.100	.125	.187
	Maximum and Minimum Flange Height Limits (h)												
5	.50	.63	.79	1.01	1.26	1.57	1.98	1.56					
	.11	.14	.18	.23	.30	.38	.52	.64					
10	.50	.63	.79	1.01	1.26	1.57	1.98	2.23	2.52	2.83	3.15	3.94	
	.11	.14	.17	.23	.28	.35	.46	.52	.59	.68	.76	1.04	
15	.56	.65	.79	1.01	1.26	1.57	1.98	2.23	2.52	2.83	3.15	3.94	5.89
	.11	.13	.17	.22	.28	.35	.44	.50	.58	.66	.74	.93	1.55
20	.62	.72	.84	1.01	1.26	1.57	1.98	2.23	2.52	2.83	3.15	3.94	5.89
	.10	.13	.17	.22	.28	.35	.44	.50	.57	.64	.72	.91	1.42
25	.67	.78	.90	1.05	1.26	1.57	1.98	2.23	2.52	2.83	3.15	3.94	5.89
	.10	.13	.17	.21	.27	.34	.44	.49	.56	.64	.71	.91	1.39
30	.70	.82	.95	1.12	1.30	1.57	1.98	2.23	2.52	2.83	3.15	3.94	5.89
	.10	.13	.16	.21	.27	.34	.43	.49	.56	.64	.71	.90	1.38
35	.74	.86	1.00	1.18	1.36	1.57	1.98	2.23	2.52	2.83	3.15	3.94	5.89
	.10	.13	.16	.21	.27	.34	.43	.49	.55	.63	.71	.89	1.36
40	.78	.90	1.05	1.23	1.44	1.65	1.98	2.23	2.52	2.83	3.15	3.94	5.89
	.10	.13	.16	.21	.26	.34	.43	.49	.55	.63	.70	.89	1.35
45	.81	.94	1.09	1.28	1.48	1.72	2.01	2.23	2.52	2.83	3.15	3.94	5.89
	.10	.13	.16	.21	.26	.34	.43	.48	.55	.63	.70	.88	1.35
50	.83	.97	1.12	1.33	1.54	1.80	2.08	2.23	2.52	2.83	3.15	3.94	5.89
	.10	.13	.16	.21	.26	.33	.42	.48	.54	.62	.69	.87	1.33
55	.86	1.02	1.17	1.38	1.60	1.85	2.14	2.34	2.52	2.83	3.15	3.94	5.89
	.10	.13	.16	.21	.26	.33	.42	.48	.54	.62	.69	.87	1.33
60	.89	1.04	1.20	1.41	1.64	1.90	2.21	2.41	2.60	2.83	3.15	3.94	5.89
	.10	.13	.16	.21	.26	.33	.42	.48	.54	.62	.69	.87	1.33
65	.91	1.06	1.24	1.47	1.70	1.95	2.26	2.48	2.68	2.88	3.15	3.94	5.89
	.10	.12	.16	.21	.26	.33	.42	.47	.54	.61	.68	.86	1.32
70	.94	1.10	1.27	1.50	1.74	2.02	2.33	2.55	2.76	2.97	3.15	3.94	5.89
	.10	.12	.16	.21	.26	.33	.42	.47	.54	.61	.68	.86	1.32

TABLE II B-14
RUBBER FORMING LIMITS
STRETCH FLANGES
L-605 (SOLUTION TREATED)

ASD TR 61-191(II)

II-41

Contour Radius R	Material Thickness (t)												
	.016	.020	.025	.032	.040	.050	.063	.071	.080	.090	.100	.125	.187
	Maximum and Minimum Flange Height Limits (h)												
5	.50	.63	.79	1.01	1.26	1.57	1.42						
	.12	.16	.20	.26	.33	.43	.72						
10	.50	.63	.79	1.01	1.26	1.57	1.98	2.23	2.52	2.83	3.15	1.75	
	.12	.15	.19	.25	.32	.40	.51	.57	.65	.76	.86	1.75	
15	.56	.65	.79	1.01	1.26	1.57	1.98	2.23	2.52	2.83	3.15	3.94	2.99
	.12	.15	.19	.24	.31	.39	.50	.56	.64	.72	.81	1.04	2.99
20	.62	.72	.84	1.01	1.26	1.57	1.98	2.23	2.52	2.83	3.15	3.94	5.89
	.11	.14	.18	.24	.30	.38	.49	.55	.63	.71	.80	1.00	1.59
25	.67	.78	.90	1.05	1.26	1.57	1.98	2.23	2.52	2.83	3.15	3.94	5.89
	.11	.14	.18	.23	.30	.38	.48	.55	.62	.70	.79	1.0	1.51
30	.70	.82	.95	1.12	1.30	1.57	1.98	2.23	2.52	2.83	3.15	3.94	5.89
	.11	.14	.18	.23	.30	.37	.48	.54	.61	.69	.78	.99	1.50
35	.74	.86	1.00	1.18	1.36	1.57	1.98	2.23	2.52	2.83	3.15	3.94	5.89
	.11	.14	.18	.23	.29	.37	.47	.54	.61	.69	.77	.99	1.50
40	.78	.90	1.05	1.23	1.44	1.65	1.98	2.23	2.52	2.83	3.15	3.94	5.89
	.11	.14	.18	.23	.29	.37	.47	.53	.60	.68	.77	.97	1.49
45	.81	.94	1.09	1.28	1.48	1.72	2.01	2.23	2.52	2.83	3.15	3.94	5.89
	.11	.14	.18	.23	.29	.36	.47	.53	.60	.68	.76	.96	1.48
50	.83	.97	1.12	1.33	1.54	1.80	2.08	2.23	2.52	2.83	3.15	3.94	5.89
	.11	.14	.17	.22	.28	.36	.46	.52	.60	.67	.75	.95	1.46
55	.86	1.02	1.17	1.38	1.60	1.85	2.14	2.34	2.52	2.83	3.15	3.94	5.89
	.11	.14	.17	.22	.28	.36	.46	.52	.60	.67	.75	.95	1.46
60	.89	1.04	1.20	1.41	1.65	1.90	2.21	2.41	2.60	2.83	3.15	3.94	5.89
	.11	.14	.17	.22	.28	.35	.45	.52	.59	.67	.75	.95	1.46
65	.91	1.06	1.24	1.47	1.70	1.95	2.26	2.48	2.68	2.88	3.15	3.94	5.89
	.11	.14	.17	.22	.28	.35	.45	.51	.58	.67	.75	.95	1.44
70	.94	1.10	1.27	1.50	1.74	2.02	2.33	2.55	2.75	2.97	3.15	3.94	5.89
	.11	.14	.17	.22	.28	.35	.45	.51	.58	.67	.74	.94	1.44

TABLE II B-15
RUBBER FORMING LIMITS
STRETCH FLANGES
J-1570 (SOLUTION TREATED)

Contour Radius R	Material Thickness (t)												
	.016	.020	.025	.032	.040	.050	.063	.071	.080	.090	.100	.125	.187
	Maximum and Minimum Flange Height Limits (h)												
5	.50	.63	.79	1.01	1.26	1.57	1.01						
	.12	.16	.20	.26	.32	.43	1.01						
10	.50	.63	.79	1.01	1.26	1.57	1.98	2.23	2.52	2.83	3.15	1.75	
	.12	.15	.19	.24	.31	.40	.50	.57	.65	.74	.85	1.75	
15	.56	.65	.79	1.01	1.26	1.57	1.98	2.23	2.52	2.83	3.15	3.94	2.80
	.12	.15	.18	.24	.30	.37	.49	.57	.64	.72	.80	1.02	2.80
20	.62	.72	.84	1.01	1.26	1.57	1.98	2.23	2.52	2.83	3.15	3.94	5.89
	.11	.14	.18	.23	.30	.37	.48	.55	.63	.71	.80	1.00	1.57
25	.67	.78	.90	1.05	1.26	1.57	1.98	2.23	2.52	2.83	3.15	3.94	5.89
	.11	.14	.18	.23	.30	.37	.47	.54	.62	.70	.78	.99	1.51
30	.70	.82	.95	1.12	1.30	1.57	1.98	2.23	2.52	2.83	3.15	3.94	5.89
	.11	.14	.18	.23	.30	.37	.47	.54	.60	.68	.77	.98	1.50
35	.74	.86	1.00	1.18	1.36	1.57	1.98	2.23	2.52	2.83	3.15	3.94	5.89
	.11	.14	.18	.23	.30	.37	.47	.53	.60	.68	.77	.98	1.50
40	.78	.90	1.05	1.23	1.44	1.65	1.98	2.23	2.52	2.83	3.15	3.94	5.89
	.11	.14	.18	.23	.29	.36	.47	.53	.60	.68	.76	.96	1.49
45	.81	.94	1.09	1.28	1.48	1.72	2.01	2.23	2.52	2.83	3.15	3.94	5.89
	.11	.14	.17	.22	.28	.36	.46	.52	.59	.67	.75	.95	1.46
50	.83	.97	1.12	1.33	1.54	1.80	2.08	2.23	2.52	2.83	3.15	3.94	5.89
	.11	.14	.17	.22	.28	.36	.46	.52	.59	.67	.75	.95	1.46
55	.86	1.02	1.17	1.38	1.60	1.85	2.14	2.34	2.52	2.83	3.15	3.94	5.89
	.11	.14	.17	.22	.28	.36	.45	.52	.59	.67	.75	.94	1.45
60	.89	1.04	1.20	1.41	1.64	1.90	2.21	2.41	2.60	2.83	3.15	3.94	5.89
	.11	.14	.17	.22	.28	.36	.45	.52	.58	.67	.74	.94	1.45
65	.91	1.06	1.24	1.47	1.70	1.95	2.26	2.48	2.68	2.88	3.15	3.94	5.88
	.11	.14	.17	.22	.28	.35	.45	.51	.58	.67	.74	.94	1.44
70	.94	1.10	1.27	1.50	1.74	2.02	2.33	2.55	2.76	2.97	3.15	3.94	5.89
	.11	.13	.17	.22	.28	.35	.45	.51	.58	.66	.74	.93	1.43

ASD TR 61-191(II)

II-42

TABLE II.B-16
RUBBER FORMING LIMITS
STRETCH FLANGES
COLUMBIUM (10 Mo-10 TH)

Contour Radius R	Material Thickness (t)												
	.016	.020	.025	.032	.040	.050	.063	.071	.080	.090	.100	.125	.157
	Maximum and Minimum Flange Height Limits (h)												
5	.31	.39	.49	.55	.56	.55							
	.14	.18	.23	.30	.38	.55							
10	.33	.39	.49	.62	.78	.97	1.10	1.12	1.10	1.13	1.14		
	.14	.18	.22	.29	.36	.46	.59	.67	.77	.90	1.07		
15	.37	.44	.50	.62	.78	.97	1.23	1.38	1.56	1.64	1.67	1.62	
	.14	.17	.22	.28	.36	.45	.57	.65	.74	.83	.93	1.21	
20	.41	.48	.55	.65	.78	.97	1.23	1.38	1.56	1.75	1.95	2.21	2.20
	.13	.17	.22	.28	.35	.45	.57	.64	.73	.83	.93	1.17	1.95
25	.44	.51	.59	.70	.81	.97	1.23	1.38	1.56	1.75	1.95	2.44	2.76
	.13	.17	.21	.27	.35	.44	.56	.64	.72	.81	.91	1.15	1.76
30	.47	.54	.63	.74	.86	1.00	1.23	1.38	1.56	1.75	1.95	2.44	3.22
	.13	.17	.21	.27	.34	.44	.56	.63	.72	.81	.91	1.14	1.75
35	.50	.57	.67	.78	.91	1.05	1.23	1.38	1.56	1.75	1.95	2.44	3.65
	.13	.16	.21	.27	.34	.43	.55	.63	.71	.80	.90	1.13	1.73
40	.51	.60	.70	.82	.95	1.10	1.30	1.38	1.56	1.75	1.95	2.44	3.65
	.13	.16	.21	.27	.34	.43	.55	.62	.70	.80	.89	1.13	1.73
45	.54	.62	.72	.85	.99	1.15	1.34	1.44	1.56	1.75	1.95	2.44	3.65
	.13	.16	.20	.27	.34	.43	.54	.62	.70	.79	.88	1.12	1.71
50	.56	.65	.75	.88	1.02	1.19	1.39	1.49	1.62	1.75	1.95	2.44	3.65
	.13	.16	.20	.27	.34	.43	.54	.62	.69	.79	.88	1.11	1.70
55	.58	.67	.77	.92	1.06	1.23	1.44	1.55	1.68	1.82	1.95	2.44	3.65
	.13	.16	.20	.26	.33	.42	.54	.61	.69	.78	.88	1.11	1.69
60	.59	.69	.80	.93	1.09	1.26	1.48	1.60	1.72	1.89	2.00	2.44	3.65
	.13	.16	.20	.26	.33	.42	.53	.60	.68	.77	.87	1.10	1.68
65	.61	.70	.81	.96	1.12	1.30	1.51	1.63	1.76	1.91	2.05	2.44	3.65
	.13	.16	.20	.26	.33	.42	.53	.60	.68	.77	.86	1.09	1.67
70	.62	.72	.84	.98	1.15	1.33	1.56	1.67	1.82	1.96	2.10	2.46	3.65
	.13	.16	.20	.26	.33	.41	.53	.60	.68	.77	.86	1.09	1.66

ASD TR 61-191(II)

II-43

TABLE II B-17
RUBBER FORMING LIMITS
STRETCH FLANGES
MOLYBDENUM (5% Ti)

Contour Radius R	Material Thickness (t)												
	.016	.020	.025	.032	.040	.050	.063	.071	.080	.090	.100	.125	.137
	Maximum and Minimum Flange Height Limits (h)												
5	.42	.42	.42	.42	.42								
					.41								
10	.45	.56	.70	.82	.82	.80	.83	.85	.84				
	.15	.18	.24	.31	.39	.49	.63	.72	.82				
15	.50	.58	.70	.89	1.12	1.25	1.26	1.28	1.26	1.26	1.27		
	.14	.18	.23	.30	.38	.48	.61	.70	.79	.90	1.00		
20	.55	.64	.74	.89	1.12	1.40	1.58	1.70	1.68	1.71	1.70	1.68	
	.14	.18	.23	.29	.37	.47	.60	.68	.78	.88	.99	1.25	
25	.60	.69	.80	.95	1.12	1.40	1.76	1.99	2.08	2.10	2.08	2.10	2.11
	.14	.17	.22	.29	.36	.46	.59	.67	.76	.86	.97	1.24	1.91
30	.63	.74	.85	1.01	1.16	1.40	1.76	1.99	2.24	2.52	2.60	2.48	2.43
	.14	.17	.22	.28	.36	.45	.58	.66	.75	.85	.95	1.21	1.87
35	.66	.77	.90	1.06	1.22	1.42	1.76	1.99	2.24	2.52	2.80	3.00	2.92
	.13	.17	.22	.28	.36	.45	.58	.65	.74	.84	.94	1.20	1.85
40	.70	.81	.94	1.10	1.28	1.49	1.76	1.99	2.24	2.52	2.80	3.38	3.36
	.13	.17	.21	.28	.35	.45	.58	.65	.74	.84	.94	1.19	1.83
45	.72	.84	.97	1.15	1.32	1.55	1.81	1.99	2.24	2.52	2.80	3.50	3.74
	.13	.17	.21	.28	.35	.45	.57	.64	.73	.83	.93	1.18	1.81
50	.74	.87	1.00	1.18	1.37	1.60	1.85	1.99	2.24	2.52	2.80	3.50	4.26
	.13	.16	.21	.27	.35	.44	.57	.64	.73	.82	.92	1.17	1.80
55	.78	.90	1.04	1.22	1.42	1.65	1.91	2.08	2.24	2.52	2.80	3.50	4.64
	.13	.16	.21	.27	.34	.44	.57	.64	.72	.82	.91	1.16	1.79
60	.80	.93	1.07	1.27	1.46	1.70	2.00	2.14	2.32	2.52	2.80	3.50	5.01
	.13	.16	.21	.27	.34	.43	.56	.64	.72	.81	.91	1.16	1.78
65	.81	.96	1.10	1.30	1.52	1.75	2.04	2.20	2.40	2.59	2.80	3.50	5.24
	.13	.16	.21	.27	.34	.43	.56	.63	.72	.81	.91	1.15	1.78
70	.84	.98	1.17	1.34	1.54	1.80	2.10	2.27	2.43	2.64	2.84	3.50	5.24
	.13	.16	.21	.27	.34	.43	.55	.63	.71	.81	.90	1.14	1.76

ASD TR 61-191(II)

II-44

TABLE II B-18
RUBBER FORMING LIMITS
SHRINK FLANGES
HM21XA-T8 (MAGNESIUM THORIUM)

Contour Radius R	Material Thickness (t)												
	.016	.020	.025	.032	.040	.050	.063	.071	.080	.090	.100	.125	.187
	Maximum and Minimum Flange Height Limits (h)												
5	0.21	0.25	0.19	0.34	0.38	0.37	0.38						
	0.09	0.11	0.14	0.19	0.23	0.29	0.38						
10	0.26	0.31	0.36	0.42	0.49	0.57	0.66	0.72	0.75	0.75	0.75	0.75	
	0.09	0.11	0.14	0.18	0.23	0.27	0.37	0.47	0.47	0.53	0.60	0.75	
15	0.31	0.35	0.38	0.48	0.55	0.65	0.76	0.81	0.88	0.96	1.00	1.15	1.14
	0.08	0.11	0.13	0.17	0.22	0.28	0.35	0.41	0.46	0.52	0.58	0.74	1.14
20	0.33	0.38	0.45	0.53	0.61	0.72	0.84	0.91	0.98	1.06	1.15	1.34	1.55
	0.08	0.10	0.13	0.17	0.22	0.28	0.35	0.40	0.45	0.51	0.58	0.73	1.12
25	0.35	0.41	0.47	0.56	0.66	0.76	0.90	0.97	1.04	1.14	1.23	1.44	1.87
	0.08	0.10	0.13	0.17	0.22	0.27	0.35	0.39	0.45	0.50	0.57	0.72	1.09
30	0.38	0.43	0.51	0.60	0.69	0.81	0.94	1.03	1.11	1.19	1.30	1.50	1.96
	0.08	0.10	0.13	0.17	0.21	0.27	0.34	0.39	0.44	0.50	0.56	0.71	1.08
35	0.39	0.46	0.53	0.62	0.73	0.85	1.00	1.07	1.18	1.16	1.36	1.59	2.05
	0.08	0.10	0.13	0.17	0.21	0.27	0.34	0.38	0.44	0.50	0.56	0.70	1.08
40	0.42	0.48	0.56	0.69	0.76	0.89	1.04	1.14	1.22	1.33	1.42	1.65	2.15
	0.08	0.10	0.13	0.16	0.21	0.27	0.34	0.38	0.44	0.50	0.56	0.70	1.06
45	0.43	0.50	0.57	0.69	0.80	0.93	1.07	1.17	1.18	1.39	1.50	1.72	2.39
	0.08	0.10	0.12	0.16	0.21	0.27	0.33	0.38	0.43	0.49	0.55	0.70	1.06
50	0.44	0.52	0.60	0.72	0.83	0.95	1.13	1.21	1.32	1.44	1.55	1.81	2.34
	0.08	0.10	0.12	0.16	0.20	0.26	0.33	0.38	0.42	0.49	0.54	0.69	1.05
55	0.46	0.54	0.62	0.73	0.86	0.98	1.15	1.26	1.36	1.48	1.59	1.85	2.39
	0.08	0.10	0.12	0.16	0.21	0.26	0.33	0.38	0.43	0.49	0.50	0.69	1.05
60	0.47	0.55	0.64	0.75	0.88	1.01	1.18	1.28	1.38	1.51	1.61	1.88	2.43
	0.08	0.10	0.13	0.16	0.21	0.26	0.33	0.38	0.43	0.49	0.54	0.69	1.05
65	0.48	0.56	0.66	0.77	0.90	1.05	1.21	1.31	1.43	1.55	1.68	1.96	2.52
	0.08	0.10	0.13	0.16	0.20	0.26	0.33	0.37	0.42	0.48	0.54	0.68	1.04
70	0.50	0.57	0.68	0.78	0.97	1.05	1.23	1.35	1.47	1.57	1.70	2.00	2.62
	0.08	0.10	0.12	0.16	0.20	0.26	0.33	0.67	0.42	0.48	0.54	0.68	1.04

ASD TR 61-191(II)

II-45

TABLE II B-19
RUBBER FORMING LIMITS
SHRINK FLANGES
2024-O ALUMINUM

ASD TR 61-191(II)

II-46

Contour Radius R	Material Thickness (t)												
	.016	.020	.025	.032	.040	.050	.063	.071	.080	.090	.100	.125	.187
	Maximum and Minimum Flange Height Limits (h)												
5	0.29	0.33	0.39	0.47	0.50	0.50	0.49	0.49	0.50	0.54	0.50		
	0.07	0.09	0.13	0.14	0.18	0.24	0.32	0.35	0.39	0.45	0.50		
10	0.35	0.42	0.49	0.57	0.7	0.77	0.91	0.97	1.02	1.02	1.05	1.05	1.02
	0.06	0.08	0.11	0.14	0.18	0.28	0.29	0.33	0.37	0.42	0.28	0.60	0.29
15	0.41	0.48	0.55	0.65	0.76	0.89	1.04	1.12	1.21	1.32	1.42	1.54	1.53
	0.07	0.08	0.11	0.14	0.17	0.22	0.29	0.33	0.37	0.42	0.47	0.60	0.92
20	0.45	0.52	0.61	0.72	0.84	0.97	1.14	1.19	1.34	1.46	1.56	1.85	2.00
	0.07	0.08	0.11	0.13	0.17	0.22	0.28	0.32	0.36	0.41	0.60	0.58	0.89
25	0.48	0.56	0.65	0.78	0.90	1.05	1.22	1.33	1.44	1.57	1.68	1.96	2.58
	0.07	0.08	0.10	0.13	0.17	0.22	0.28	0.31	0.35	0.40	0.45	0.58	0.90
30	0.51	0.59	0.70	0.82	0.96	1.11	1.29	1.40	1.52	1.63	1.77	2.05	2.73
	0.05	0.08	0.10	0.13	0.17	0.21	0.22	0.31	0.35	0.40	0.44	0.57	0.86
35	0.51	0.61	0.73	0.91	1.00	1.16	1.35	1.48	1.60	1.72	1.85	2.16	2.82
	0.06	0.08	0.10	0.13	0.17	0.21	0.27	0.30	0.35	0.40	0.44	0.56	0.86
40	0.57	0.66	0.77	0.90	1.04	1.21	1.43	1.54	1.66	1.80	1.93	2.25	2.95
	0.06	0.08	0.10	0.13	0.16	0.21	0.26	0.30	0.34	0.39	0.44	0.56	0.86
45	0.52	0.68	0.77	0.93	1.08	1.25	1.47	1.60	1.74	1.89	2.02	2.35	3.08
	0.06	0.08	0.10	0.13	0.16	0.21	0.26	0.30	0.34	0.39	0.44	0.55	0.85
50	0.61	0.70	1.83	0.98	1.12	1.32	1.54	1.63	1.78	1.95	2.09	2.44	3.20
	0.06	0.08	0.10	0.13	0.16	0.21	0.23	0.30	0.34	0.38	0.43	0.55	0.84
55	0.63	0.72	0.85	1.00	1.16	1.35	1.58	1.70	1.86	2.02	2.17	2.56	3.33
	0.06	0.08	0.10	0.13	0.16	0.21	0.26	0.30	0.34	0.38	0.43	0.55	0.84
60	0.64	0.74	0.86	1.02	1.18	1.38	1.63	1.73	1.88	1.04	2.20	2.56	3.35
	0.06	0.08	0.10	0.13	0.16	0.20	0.26	0.30	0.34	0.38	0.43	0.54	0.82
65	0.66	0.76	0.89	1.04	1.22	1.41	1.66	1.78	1.94	2.12	2.27	2.63	3.48
		0.08	0.10	0.13	0.16	0.20	0.26	0.30	0.34	0.38	0.43	0.54	0.82
70	0.67	0.79	0.91	1.07	1.24	1.45	1.70	1.85	2.00	2.16	2.30	2.69	3.51
		0.08	0.10	0.13	0.16	0.20	0.25	0.30	0.34	0.38	0.42	0.54	0.82

TABLE II B-20
RUBBER FORMING LIMITS
SHRINK FLANGES
17-7 PH (CONDITION A)

ASD TR 61-191(II)

II-47

Contour Radius R	Material Thickness (t)												
	.016	.020	.025	.032	.040	.050	.063	.071	.080	.090	.100	.125	.167
	Maximum and Minimum Flange Height Limits (h)												
5	0.18	0.18	0.18										
	0.11	0.14	0.17										
10	0.32	0.37	0.37	0.37	0.36	0.36							
	0.10	0.13	0.16	0.22	0.28	0.35							
15	0.37	0.43	0.50	0.54	0.54	0.55	0.55	0.53	0.56				
	0.10	0.13	0.16	0.21	0.27	0.34	0.44	0.49	0.56				
20	0.41	0.47	0.55	0.65	0.74	0.74	0.74	0.74	0.73	0.73	0.74		
	0.10	0.13	0.16	0.21	0.26	0.33	0.42	0.48	0.54	0.62	0.70		
25	0.44	0.51	0.60	0.70	0.82	0.92	0.92	0.92	0.92	0.93	0.90	0.93	
	0.10	0.13	0.16	0.21	0.26	0.33	0.42	0.48	0.54	0.62	0.69	0.88	
30	0.46	0.54	0.62	0.74	0.86	1.00	1.07	1.09	1.08	1.08	1.08	1.08	
	0.09	0.12	0.16	0.21	0.26	0.33	0.42	0.48	0.54	0.61	0.68	0.86	
35	0.50	0.57	0.65	0.78	0.92	1.05	1.23	1.28	1.28	1.26	1.28	1.29	
	0.09	0.12	0.16	0.21	0.26	0.33	0.49	0.47	0.54	0.60	0.68	0.86	
40	0.51	0.60	0.70	0.82	0.94	1.10	1.29	1.39	1.44	1.44	1.45	1.44	1.48
	0.09	0.12	0.15	0.20	0.26	0.33	0.49	0.46	0.53	0.59	0.67	0.85	1.31
45	0.53	0.62	0.71	0.83	0.96	1.15	1.32	1.46	1.55	1.62	1.65	1.63	1.63
	0.09	0.12	0.15	0.20	0.25	0.32	0.49	0.46	0.52	0.59	0.67	0.85	1.29
50	0.54	0.64	0.75	0.88	1.02	1.20	1.39	1.49	1.62	1.77	1.80	1.88	1.81
	0.09	0.12	0.15	0.20	0.25	0.32	0.49	0.46	0.52	0.58	0.66	0.84	1.29
55	0.57	0.66	0.78	0.90	1.04	1.22	1.45	1.56	1.68	1.80	1.95	2.06	2.02
	0.10	0.12	0.15	0.20	0.25	0.32	0.43	0.46	0.52	0.58	0.65	0.83	1.27
60	0.58	0.68	0.80	0.93	1.08	1.25	1.48	1.60	1.72	1.89	2.00	2.15	2.11
	0.10	0.12	0.15	0.19	0.25	0.32	0.43	0.46	0.52	0.59	0.65	0.83	1.27
65	0.61	0.70	0.81	0.96	1.12	1.30	1.51	1.63	1.76	1.93	2.07	2.40	2.39
	0.10	0.12	0.15	0.19	0.25	0.32	0.43	0.45	0.51	0.58	0.65	0.83	1.27
70	0.61	0.72	0.83	0.99	1.12	1.32	1.54	1.67	1.80	1.98	2.10	2.44	2.52
	0.10	0.12	0.15	0.19	0.25	0.32	0.43	0.45	0.51	0.59	0.65	0.83	1.25

TABLE II B-21
RUBBER FORMING LIMITS
SHRINK FLANGES
PH 15-7 Mo (CONDITION A)

Contour Radius R	Material Thickness (t)												
	.016	.020	.025	.032	.040	.050	.063	.071	.080	.090	.100	.125	.187
	maximum and Minimum Flange Height Limits (h)												
5	0.15	0.17											
	0.12	0.14											
10	0.30	0.30	0.30	0.30	0.30								
	0.11	0.14	0.17	0.22	0.28								
15	0.38	0.44	0.45	0.45	0.45	0.47	0.47						
	0.11	0.13	0.16	0.22	0.28	0.35	0.45						
20	0.42	0.49	0.58	0.61	0.62	0.63	0.62	0.62	0.62				
	0.10	0.13	0.16	0.22	0.27	0.35	0.44	0.50	0.56				
25	0.45	0.52	0.61	0.71	0.77	0.78	0.76	0.75	0.75	0.78	0.78		
	0.10	0.13	0.16	0.21	0.27	0.34	0.44	0.49	0.56	0.63	0.70		
30	0.47	0.55	0.65	0.77	0.87	0.92	0.90	0.89	0.90	0.89	0.93	0.89	
	0.10	0.13	0.16	0.21	0.27	0.34	0.43	0.48	0.55	0.62	0.69	0.87	
35	0.51	0.59	0.68	0.80	0.94	1.05	1.06	1.08	1.06	1.09	1.09	1.09	
	0.10	0.13	0.16	0.21	0.27	0.34	0.43	0.48	0.55	0.62	0.69	0.87	
40	0.53	0.61	0.71	0.84	0.97	1.14	1.23	1.20	1.70	1.12	1.24	1.22	
	0.10	0.13	0.16	0.21	0.26	0.33	0.42	0.48	0.55	0.61	0.69	0.87	
45	0.55	0.64	0.74	0.87	1.01	1.20	1.39	1.36	1.38	1.37	1.39	1.40	1.40
	0.10	0.13	0.16	0.21	0.26	0.33	0.42	0.48	0.55	0.61	0.69	0.87	1.32
50	0.57	0.66	0.77	0.91	1.06	1.23	1.45	1.41	1.49	1.53	1.54	1.55	1.57
	0.10	0.13	0.16	0.21	0.26	0.33	0.42	0.48	0.54	0.61	0.68	0.86	1.31
55	0.58	0.68	0.79	0.93	1.08	1.25	1.47	1.58	1.69	1.70	1.68	1.73	1.69
	0.10	0.12	0.16	0.21	0.26	0.33	0.42	0.47	0.53	0.60	0.68	0.85	1.31
60	0.61	0.70	0.81	0.96	1.12	1.30	1.51	1.63	1.76	1.80	1.83	1.81	1.82
	0.10	0.12	0.16	0.21	0.26	0.33	0.42	0.47	0.53	0.60	0.68	0.85	1.31
65	0.62	0.71	0.83	0.98	1.14	1.33	1.54	1.67	1.81	1.98	1.96	2.00	1.97
	0.10	0.12	0.16	0.21	0.26	0.33	0.41	0.47	0.53	0.59	0.67	0.85	1.31
70	0.63	0.73	0.85	1.00	1.16	1.35	1.57	1.70	1.84	2.01	2.10	2.10	2.12
	0.10	0.12	0.16	0.21	0.26	0.33	0.41	0.47	0.53	0.59	0.67	0.85	1.31

ASD TR 61-191(II)

II-48

TABLE II B-22
RUBBER FORMING LIMITS
SHRINK FLANGES
AM-350 (ANNEALED)

ASD TR 61-191(II)

II-49

Contour Radius R	Material Thickness (t)												
	.016	.020	.025	.032	.040	.050	.063	.071	.080	.090	.100	.125	.187
	Maximum and Minimum Flange Height Limits (h)												
5	0.12												
	0.12												
10	0.25	0.25	0.25	0.24									
	0.12	0.15	0.19	0.24									
15	0.35	0.37	0.38	0.37	0.37	0.38							
	0.11	0.14	0.18	0.23	0.30	0.38							
20	0.38	0.45	0.50	0.51	0.51	0.51	0.51						
	0.11	0.14	0.18	0.23	0.30	0.37	0.47						
25	0.41	0.48	0.56	0.61	0.62	0.62	0.62	0.62	0.62				
	0.11	0.14	0.18	0.23	0.29	0.37	0.47	0.53	0.60				
30	0.44	0.51	0.60	0.70	0.74	0.74	0.74	0.74	0.74	0.74			
	0.11	0.14	0.18	0.23	0.29	0.37	0.47	0.53	0.60	0.68			
35	0.46	0.54	0.63	0.74	0.84	0.88	0.88	0.85	0.88	0.86	0.86		
	0.11	0.14	0.18	0.22	0.28	0.36	0.46	0.53	0.59	0.68	0.75		
40	0.48	0.56	0.65	0.77	0.88	0.99	1.01	1.00	1.00	0.99	1.00	1.00	
	0.11	0.14	0.17	0.22	0.28	0.36	0.45	0.51	0.58	0.67	0.74	0.94	
45	0.50	0.58	0.68	0.80	0.92	1.09	1.12	1.12	1.12	1.14	1.15	1.12	
	0.11	0.14	0.17	0.22	0.28	0.36	0.45	0.51	0.58	0.67	0.74	0.94	
50	0.51	0.60	0.70	0.83	0.97	1.10	1.26	1.24	1.24	1.26	1.26	1.25	
	0.11	0.14	0.17	0.22	0.28	0.35	0.45	0.51	0.58	0.66	0.74	0.93	
55	0.53	0.62	0.72	0.84	1.00	1.15	1.32	1.35	1.36	1.39	1.40	1.37	
	0.11	0.13	0.17	0.22	0.28	0.35	0.44	0.50	0.58	0.65	0.73	0.93	
60	0.54	0.64	0.74	0.86	1.02	1.17	1.39	1.49	1.48	1.48	1.50	1.47	1.46
	0.11	0.13	0.17	0.22	0.28	0.35	0.44	0.50	0.58	0.65	0.73	0.93	1.40
65	0.56	0.66	0.76	0.90	1.04	1.20	1.42	1.53	1.60	1.62	1.60	1.62	1.59
	0.11	0.13	0.17	0.22	0.28	0.35	0.44	0.50	0.58	0.65	0.73	0.93	0.40
70	0.58	0.66	0.78	0.91	1.06	1.24	1.45	1.56	1.68	1.71	1.70	1.72	1.72
	0.11	0.13	0.17	0.22	0.28	0.35	0.44	0.50	0.58	0.65	0.72	0.91	1.38

TABLE II B-23
 RUBBER FORMING LIMITS
 SHRINK FLANGES
 A-286 (SOLUTION TREATED)

Contour Radius R	Material Thickness (t)												
	.016	.020	.025	.032	.040	.050	.063	.071	.080	.090	.100	.125	.187
Maximum and Minimum Flange Height Limits (h)													
5	0.18	0.18	0.18										
	0.11	0.14	0.18										
10	0.34	0.36	0.37	0.37	0.37	0.37							
	0.11	0.13	0.17	0.22	0.28	0.35							
15	0.38	0.45	0.53	0.55	0.55	0.55	0.56	0.53	0.56				
	0.10	0.13	0.17	0.21	0.27	0.34	0.44	0.50	0.56				
20	0.42	0.50	0.58	0.68	0.73	0.75	0.73	0.74	0.74	0.74	0.73		
	0.10	0.13	0.16	0.21	0.27	0.34	0.43	0.48	0.55	0.63	0.70		
25	0.45	0.53	0.62	0.73	0.84	0.93	0.93	0.92	0.92	0.94	0.94	0.91	
	0.10	0.13	0.16	0.21	0.27	0.37	0.42	0.48	0.54	0.62	0.69	0.88	
30	0.48	0.56	0.65	0.77	0.90	1.05	1.08	0.96	1.10	1.08	1.10	1.09	
	0.10	0.12	0.16	0.21	0.27	0.33	0.42	0.48	0.54	0.61	0.69	0.88	
35	0.51	0.59	0.72	0.82	0.95	1.10	1.28	1.29	1.28	1.26	1.28	1.30	
	0.10	0.12	0.16	0.21	0.27	0.33	0.42	0.48	0.54	0.61	0.68	0.86	
40	0.54	0.62	0.73	0.85	1.00	1.15	1.35	1.45	1.44	1.44	1.46	1.44	1.46
	0.10	0.12	0.16	0.21	0.27	0.33	0.42	0.47	0.54	0.61	0.68	0.86	1.31
45	0.56	0.64	0.75	0.88	1.08	1.20	1.39	1.54	1.66	1.63	1.68	1.65	1.65
	0.10	0.12	0.16	0.20	0.26	0.32	0.41	0.47	0.53	0.60	0.68	0.86	1.31
50	0.58	0.68	0.78	0.93	1.10	1.25	1.45	1.56	1.86	1.84	1.85	1.87	1.87
	0.10	0.12	0.16	0.20	0.25	0.33	0.41	0.46	0.53	0.59	0.67	0.84	1.29
55	0.59	0.68	0.80	0.94	1.12	1.28	1.50	1.62	1.76	1.89	2.03	2.10	2.02
	0.10	0.12	0.16	0.20	0.25	0.32	0.41	0.46	0.52	0.59	0.66	0.84	1.29
60	0.61	0.70	0.83	0.96	1.16	1.30	1.53	1.65	1.78	1.95	2.10	2.19	2.19
	0.10	0.12	0.15	0.20	0.25	0.32	0.41	0.46	0.52	0.59	0.66	0.84	1.27
65	0.62	0.72	0.85	0.99	1.18	1.35	1.57	1.70	1.84	2.02	2.15	2.42	2.37
	0.10	0.12	0.15	0.20	0.25	0.32	0.41	0.46	0.52	0.59	0.66	0.83	1.27
70	0.64	0.74	0.88	1.02	1.19	1.38	1.61	1.74	1.88	2.05	2.20	2.50	2.49
	0.10	0.12	0.15	0.20	0.25	0.32	0.40	0.46	0.52	0.59	0.65	0.83	1.27

ASD TR 61-191(II)

II-50

TABLE II B-24
 RUBBER FORMING LIMITS
 SHRINK FLANGES
 USS-12-MoV (ANNEALED)

Contour Radius R	Material Thickness (t)												
	.016	.020	.025	.032	.040	.050	.063	.071	.080	.090	.100	.125	.187
	Maximum and Minimum Flange Height Limits (h)												
5													
10	0.24	0.24	0.24										
	0.12	0.16	0.20										
15	0.36	0.36	0.36	0.36	0.36								
	0.12	0.15	0.19	0.25	0.32								
20	0.40	0.47	0.49	0.48	0.48	0.48							
	0.12	0.15	0.19	0.25	0.31	0.40							
25	0.43	0.51	0.59	0.59	0.60	0.60	0.60	0.60					
	0.12	0.15	0.19	0.24	0.31	0.39	0.50	0.57					
30	0.46	0.53	0.62	0.71	0.71	0.70	0.71	0.71	0.70				
	0.12	0.15	0.19	0.24	0.30	0.39	0.49	0.55	0.64				
35	0.49	0.56	0.65	0.77	0.84	0.85	0.84	0.85	0.84	0.84	0.84		
	0.12	0.15	0.19	0.24	0.30	0.39	0.49	0.55	0.63	0.72	0.80		
40	0.50	0.59	0.69	0.81	0.94	0.95	0.96	0.96	1.10	0.95	0.95		
	0.11	0.14	0.18	0.23	0.30	0.38	0.48	0.55	0.62	0.71	0.80		
45	0.53	0.62	0.73	0.85	0.98	1.11	1.08	1.09	1.18	1.10	1.10	1.10	
	0.11	0.14	0.18	0.23	0.30	0.38	0.48	0.55	0.62	0.70	0.79	1.00	
50	0.55	0.64	0.75	0.88	1.03	1.20	1.21	1.21	1.20	1.21	1.22	1.23	
	0.11	0.14	0.18	0.23	0.30	0.38	0.48	0.55	0.62	0.70	0.79	1.00	
55	0.57	0.66	0.77	0.91	1.05	1.22	1.35	1.35	1.36	1.35	1.35	1.36	
	0.11	0.14	0.18	0.23	0.28	0.38	0.47	0.54	0.62	0.69	0.78	0.99	
60	0.58	0.67	0.79	0.93	1.08	1.25	1.45	1.42	1.44	1.44	1.45	1.44	
	0.11	0.14	0.18	0.23	0.29	0.37	0.47	0.53	0.61	0.68	0.77	0.98	
65	0.59	0.69	0.80	0.96	1.11	1.29	1.49	1.56	1.56	1.57	1.57	1.59	1.55
	0.11	0.14	0.18	0.23	0.29	0.37	0.47	0.53	0.60	0.68	0.76	0.96	1.50
70	0.61	0.71	0.83	0.96	1.12	1.30	1.52	1.65	1.64	1.65	1.68	1.66	1.66
	0.11	0.14	0.18	0.23	0.29	0.27	0.47	0.53	0.60	0.68	0.76	0.96	1.50

ASD TR 61-191(II)

II-51

TABLE II B-25
RUBBER FORMING LIMITS
SHRINK FLANGES
TITANIUM (6Al-4V) (MILL ANNEALED)

ASD TR 61-191(II)

II-52

Contour Radius R	Material Thickness (t)												
	.016	.020	.025	.032	.040	.050	.063	.071	.080	.090	.100	.125	.187
	Maximum and Minimum Flange Height Limits (h)												
5													
10													
15	0.16												
	0.15												
20	0.21	0.22											
	0.15	0.18											
25	0.26	0.27	0.28										
	0.15	0.18	0.23										
30	0.28	0.32	0.32	0.32									
	0.14	0.18	0.23	0.29									
35	0.29	0.34	0.38	0.37									
	0.14	0.18	0.22	0.29									
40	0.31	0.35	0.41	0.44	0.44								
	0.14	0.17	0.23	0.29	0.37								
45	0.32	0.37	0.43	0.48	0.48	0.50							
	0.14	0.17	0.22	0.29	0.36	0.46							
50	0.33	0.38	0.45	0.53	0.56	0.56							
	0.14	0.17	0.22	0.29	0.36	0.46							
55	0.34	0.39	0.48	0.54	0.60	0.60							
	0.14	0.17	0.21	0.29	0.36	0.46							
60	0.35	0.40	0.47	0.55	0.64	0.65	0.65						
	0.14	0.17	0.21	0.29	0.36	0.45	0.58						
65	0.36	0.42	0.48	0.58	0.66	0.70	0.70	0.70					
	0.14	0.17	0.21	0.29	0.36	0.45	0.57	0.66					
70	0.36	0.42	0.49	0.58	0.68	0.75	0.75	0.75					
	0.14	0.17	0.21	0.28	0.36	0.45	0.57	0.65					

TABLE II B-26
 RUBBER FORMING LIMITS
 SHRINK FLANGES
 TITANIUM (13V-11Cr-3Al) (SOLUTION TREATED)

Contour Radius R	Material Thickness (t)												
	.016	.020	.025	.032	.040	.050	.063	.071	.080	.090	.100	.125	.157
	Maximum and Minimum Flange Height Limits (h)												
5													
10													
15	0.16												
	0.15												
20	0.21	0.21											
	0.14	0.18											
25	0.26	0.26	0.26										
	0.14	0.18	0.23										
30	0.28	0.32	0.32	0.32									
	0.14	0.18	0.23	0.30									
35	0.29	0.34	0.36	0.37									
	0.14	0.18	0.23	0.30									
40	0.30	0.35	0.41	0.42	0.42								
	0.14	0.18	0.23	0.29	0.37								
45	0.32	0.36	0.43	0.40	0.48	0.48							
	0.14	0.18	0.22	0.29	0.36	0.47							
50	0.32	0.38	0.44	0.52	0.52	0.53							
	0.14	0.17	0.22	0.29	0.36	0.46							
55	0.34	0.39	0.45	0.54	0.58	0.58							
	0.14	0.17	0.22	0.29	0.36	0.45							
60	0.34	0.40	0.46	0.54	0.62	0.63	0.63						
	0.14	0.17	0.22	0.29	0.36	0.46	0.59						
65	0.35	0.41	0.48	0.56	0.65	0.68	0.68	0.68					
	0.13	0.17	0.22	0.28	0.37	0.45	0.58	0.66					
70	0.36	0.42	0.49	0.58	0.66	0.70	0.72	0.71					
	0.13	0.17	0.22	0.28	0.37	0.45	0.58	0.66					

ASD TR 61-191(II)

II-53

TABLE II B-27
RUBBER FORMING LIMITS
SHRINK FLANGES
VASCOJET 1000 (H-11) (ANNEALED)

Contour Radius R	Material Thickness (t)												
	.016	.020	.025	.032	.040	.050	.063	.071	.080	.090	.100	.125	.187
	Maximum and Minimum Flange Height Limits (h)												
5													
10	0.18	0.18											
	0.13	0.16											
15	0.27	0.26	0.28	0.28									
	0.12	0.16	0.20	0.25									
20	0.35	0.36	0.35	0.35	0.36								
	0.12	0.15	0.19	0.25	0.32								
25	0.40	0.44	0.45	0.45	0.46	0.46							
	0.12	0.15	0.19	0.25	0.32	0.40							
30	0.43	0.50	0.50	0.54	0.54	0.55	0.55						
	0.12	0.15	0.19	0.25	0.31	0.39	0.50						
35	0.45	0.52	0.60	0.62	0.64	0.63	0.63	0.63					
	0.12	0.15	0.19	0.25	0.31	0.39	0.50	0.57					
40	0.46	0.54	0.63	0.74	0.72	0.70	0.73	0.71	0.72				
	0.12	0.15	0.19	0.25	0.31	0.39	0.49	0.57	0.64				
45	0.50	0.58	0.65	0.77	0.80	0.80	0.82	0.84	0.80	0.81	0.82		
	0.12	0.15	0.19	0.24	0.30	0.39	0.50	0.57	0.64	0.73	0.82		
50	0.51	0.59	0.68	0.80	0.92	0.90	0.91	0.92	0.88	0.98	0.90		
	0.12	0.15	0.19	0.24	0.30	0.38	0.49	0.56	0.64	0.72	0.80		
55	0.53	0.62	0.70	0.84	0.96	1.00	1.01	1.00	1.04	0.90	1.00		
	0.12	0.14	0.19	0.24	0.30	0.39	0.49	0.56	0.64	0.72	0.80		
60	0.54	0.63	0.73	0.86	1.00	1.05	1.06	1.06	1.07	1.08	1.02	1.06	
	0.11	0.15	0.19	0.24	0.30	0.39	0.49	0.55	0.63	0.71	0.80	1.00	
65	0.56	0.64	0.75	0.90	1.04	1.20	1.13	1.21	1.20	1.17	1.20	1.20	
	0.11	0.15	0.19	0.24	0.30	0.38	0.49	0.55	0.63	0.71	0.80	1.00	
70	0.57	0.65	0.76	0.90	1.06	1.25	1.15	1.23	1.25	1.19	1.25	1.20	
	0.11	0.15	0.19	0.24	0.30	0.38	0.48	0.55	0.62	0.70	0.80	1.00	

ASD TR 61-191(II)

II-54

TABLE II B-28
RUBBER FORMING LIMITS
SHRINK FLANGES
RENE 41 (SOLUTION TREATED)

Contour Radius R	Material Thickness (t)												
	.016	.020	.025	.032	.040	.050	.063	.071	.080	.090	.100	.125	.157
	Maximum and Minimum Flange Height Limits (h)												
5													
10	0.22	0.22	0.23										
	0.12	0.15	0.20										
15	0.34	0.33	0.33	0.33	0.33								
	0.12	0.15	0.19	0.25	0.31								
20	0.38	0.44	0.45	0.45	0.44	0.45							
	0.12	0.15	0.19	0.24	0.31	0.39							
25	0.42	0.48	0.55	0.55	0.56	0.55	0.55						
	0.11	0.15	0.19	0.24	0.30	0.39	0.49						
30	0.45	0.52	0.60	0.64	0.68	0.65	0.65	0.66	0.66				
	0.11	0.14	0.18	0.24	0.30	0.38	0.49	0.55	0.63				
35	0.47	0.54	0.63	0.74	0.80	0.80	0.79	0.78	0.71	0.79			
	0.11	0.14	0.18	0.23	0.30	0.38	0.48	0.55	0.62	0.70			
40	0.50	0.58	0.65	0.77	0.88	0.90	0.88	0.86	0.88	0.90	0.90		
	0.11	0.14	0.18	0.23	0.30	0.38	0.48	0.54	0.61	0.70	0.79		
45	0.51	0.60	0.70	0.80	0.92	1.05	1.01	1.00	1.00	1.00	1.00	1.02	
	0.11	0.14	0.18	0.22	0.29	0.37	0.47	0.53	0.60	0.68	0.78	0.99	
50	0.53	0.62	0.71	0.83	0.96	1.10	1.13	1.06	1.12	1.12	1.10	1.12	
	0.11	0.14	0.18	0.22	0.29	0.37	0.47	0.53	0.60	0.68	0.78	0.98	
55	0.54	0.62	0.73	0.86	1.00	1.15	1.20	1.21	1.20	1.26	1.20	1.25	
	0.11	0.14	0.18	0.22	0.29	0.37	0.47	0.53	0.60	0.68	0.76	0.96	
60	0.56	0.64	0.75	0.90	1.04	1.20	1.32	1.31	1.28	1.35	1.30	1.35	
	0.11	0.14	0.18	0.22	0.29	0.37	0.47	0.53	0.60	0.68	0.76	0.96	
65	0.58	0.66	0.78	0.90	1.05	1.28	1.45	1.45	1.45	1.45	1.45	1.50	
	0.11	0.14	0.17	0.22	0.28	0.36	0.46	0.53	0.60	0.68	0.76	0.96	
70	0.59	0.67	0.79	0.91	1.09	1.31	1.48	1.46	1.47	1.45	1.45	1.59	1.57
	0.11	0.14	0.17	0.23	0.28	0.36	0.46	0.53	0.60	0.68	0.76	0.96	1.46

ASD TR 61-191(II)

II-55

TABLE II B-29
RUBBER FORMING LIMITS
SHRINK FLANGES
INCONEL X (C.R. ANNEALED)

Contour Radius R	Material Thickness (t)												
	.016	.020	.025	.032	.040	.050	.063	.071	.080	.090	.100	.125	.157
	Maximum and Minimum Flange Height Limits (h)												
5	0.15	0.15											
	0.11	0.15											
10	0.29	0.29	0.29	0.29	0.29								
	0.11	0.14	0.18	0.23	0.29								
15	0.38	0.44	0.44	0.44	0.44	0.44							
	0.11	0.13	0.17	0.22	0.28	0.36							
20	0.42	0.48	0.56	0.60	0.60	0.59	0.60	0.60	0.67				
	0.11	0.13	0.17	0.22	0.28	0.35	0.44	0.50	0.58				
25	0.44	0.52	0.60	0.70	0.74	0.75	0.72	0.73	0.74	0.75	0.75		
	0.11	0.13	0.16	0.21	0.27	0.36	0.44	0.49	0.56	0.64	0.72		
30	0.47	0.54	0.65	0.75	0.88	0.87	0.87	0.87	0.87	0.86	0.88		
	0.11	0.13	0.16	0.21	0.27	0.34	0.44	0.50	0.56	0.64	0.72		
35	0.50	0.58	0.68	0.80	0.92	1.05	1.02	1.04	1.04	1.03	1.02	1.05	
	0.11	0.13	0.16	0.21	0.27	0.34	0.44	0.50	0.56	0.64	0.72	0.91	
40	0.52	0.60	0.70	0.83	0.96	1.11	1.18	1.16	1.16	1.17	1.17	1.15	
	0.11	0.13	0.16	0.21	0.27	0.34	0.43	0.50	0.56	0.63	0.71	0.90	
45	0.54	0.62	0.73	0.86	1.00	1.16	1.35	1.33	1.34	1.35	1.35	1.34	
	0.10	0.13	0.16	0.21	0.26	0.34	0.43	0.49	0.56	0.63	0.70	0.89	
50	0.56	0.66	0.76	0.90	1.05	1.21	1.42	1.49	1.49	1.51	1.51	1.51	1.51
	0.11	0.13	0.16	0.21	0.26	0.34	0.43	0.49	0.56	0.63	0.70	0.89	1.35
55	0.58	0.66	0.78	0.91	1.07	1.13	1.45	1.56	1.62	1.64	1.62	1.66	1.59
	0.11	0.13	0.16	0.21	0.26	0.34	0.42	0.48	0.55	0.62	0.70	0.88	1.35
60	0.59	0.68	0.80	0.94	1.10	1.28	1.49	1.60	1.76	1.76	1.76	1.76	1.74
	0.11	0.13	0.16	0.21	0.26	0.33	0.42	0.48	0.54	0.62	0.69	0.87	1.35
65	0.61	0.70	0.82	0.97	1.12	1.30	1.51	1.63	1.78	1.90	1.92	1.94	1.93
	0.10	0.13	0.16	0.21	0.26	0.33	0.42	0.48	0.54	0.62	0.69	0.88	1.33
70	0.62	0.72	0.85	0.99	1.16	1.35	1.58	1.70	1.84	1.98	2.05	2.00	2.06
	0.11	0.13	0.16	0.21	0.26	0.33	0.42	0.48	0.54	0.62	0.69	0.88	1.33

ASD TR 61-191(II)

II-56

TABLE II B-30
RUBBER FORMING LIMITS
SHRINK FLANGES
HASTELLOY X (SOLUTION TREATED)

Contour Radius R	Material Thickness (t)												
	.016	.020	.025	.032	.040	.050	.063	.071	.080	.090	.100	.125	.187
	Maximum and Minimum Flange Height Limits (h)												
5	0.15	0.17											
	0.11	0.14											
10	0.30	0.30	0.30	0.30	0.30								
	0.10	0.14	0.17	0.22	0.28								
15	0.38	0.44	0.45	0.45	0.45	0.45	0.45						
	0.10	0.13	0.16	0.22	0.28	0.35	0.45						
20	0.42	0.42	0.49	0.58	0.61	0.61	0.61	0.61	0.61				
	0.10	0.13	0.16	0.22	0.27	0.35	0.44	0.50	0.56				
25	0.45	0.52	0.61	0.71	0.76	0.75	0.76	0.75	0.75	0.76	0.75		
	0.10	0.13	0.16	0.21	0.27	0.34	0.44	0.49	0.56	0.63	0.70		
30	0.50	0.55	0.65	0.77	0.88	0.90	0.90	0.89	0.90	0.89	0.90	0.88	
	0.11	0.13	0.16	0.21	0.27	0.34	0.43	0.48	0.55	0.62	0.69	0.88	
35	0.51	0.59	0.68	0.80	0.94	1.05	1.06	1.06	1.06	1.06	1.06	1.07	
	0.11	0.13	0.16	0.21	0.27	0.34	0.43	0.48	0.55	0.62	0.69	0.88	
40	0.53	0.61	0.71	0.84	0.97	1.14	1.23	1.20	1.20	1.20	1.20	1.20	
	0.10	0.13	0.16	0.21	0.26	0.33	0.42	0.48	0.54	0.61	0.69	0.88	
45	0.55	0.64	0.74	0.87	1.01	1.20	1.39	1.36	1.37	1.38	1.38	1.39	1.36
	0.10	0.13	0.16	0.21	0.26	0.33	0.42	0.48	0.54	0.61	0.69	0.88	1.33
50	0.57	0.66	0.77	0.91	1.06	1.23	1.45	1.47	1.49	1.53	1.53	1.53	1.53
	0.10	0.13	0.16	0.21	0.26	0.33	0.42	0.48	0.54	0.61	0.68	0.86	1.31
55	0.58	0.68	0.78	0.93	1.08	1.25	1.47	1.58	1.69	1.70	1.68	1.72	1.64
	0.10	0.13	0.16	0.21	0.26	0.37	0.42	0.48	0.54	0.61	0.68	0.86	1.31
60	0.61	0.70	0.81	0.96	1.12	1.13	1.15	1.63	1.76	1.80	1.83	1.81	1.79
	0.10	0.13	0.16	0.21	0.26	0.33	0.42	0.48	0.54	0.61	0.68	0.86	1.31
65	0.62	0.71	0.83	0.98	1.14	1.32	1.54	1.67	1.81	1.98	1.96	2.0	1.93
	0.10	0.12	0.16	0.21	0.26	0.33	0.41	0.47	0.53	0.59	0.67	0.85	1.31
70	0.63	0.73	0.85	1.00	1.16	1.35	1.57	1.70	1.84	2.01	2.10	2.10	2.09
	0.10	0.12	0.16	0.21	0.26	0.33	0.41	0.47	0.53	0.59	0.67	0.85	1.31

ASD TR 61-191(II)

II-57

TABLE II B-31
RUBBER FORMING LIMITS
SHRINK FLANGES
L-605 (SOLUTION TREATED)

Contour Radius R	Material Thickness (t)												
	.016	.020	.025	.032	.040	.050	.063	.071	.080	.090	.100	.125	.187
	Maximum and Minimum Flange Height Limits (h)												
5	0.13												
	0.13												
10	0.26	0.26	0.27	0.27									
	0.12	0.15	0.19	0.25									
15	0.39	0.40	0.31	0.40	0.40	0.40							
	0.12	0.15	0.19	0.24	0.31	0.39							
20	0.45	0.50	0.52	0.54	0.54	0.54	0.54						
	0.11	0.14	0.19	0.24	0.30	0.38	0.49						
25	0.46	0.54	0.59	0.66	0.66	0.66	0.66	0.66	0.67				
	0.11	0.14	0.19	0.24	0.30	0.38	0.48	0.55	0.62				
30	0.48	0.56	0.61	0.78	0.79	0.80	0.79	0.79	0.78	0.79	0.80		
	0.11	0.14	0.18	0.23	0.29	0.37	0.47	0.53	0.61	0.69	0.78		
35	0.51	0.60	0.65	0.83	0.94	0.91	0.92	0.93	0.92	0.92	0.91		
	0.11	0.14	0.18	0.23	0.29	0.37	0.47	0.53	0.61	0.68	0.77		
40	0.54	0.63	0.68	0.86	1.00	1.06	1.05	1.03	1.03	1.04	1.05	1.06	
	0.11	0.14	0.18	0.23	0.29	0.37	0.47	0.53	0.60	0.68	0.76	0.96	
45	0.56	0.65	0.70	0.89	1.04	1.22	1.20	1.21	1.20	1.22	1.25	1.22	
	0.11	0.14	0.18	0.22	0.29	0.37	0.47	0.53	0.60	0.68	0.76	0.96	
50	0.58	0.68	0.73	0.93	1.08	1.25	1.36	1.34	1.35	1.35	1.35	1.35	
	0.11	0.14	0.18	0.22	0.28	0.35	0.45	0.52	0.59	0.67	0.75	0.95	
55	0.60	0.70	0.75	0.96	1.12	1.30	1.51	1.49	1.48	1.53	1.50	1.50	1.50
	0.11	0.14	0.18	0.22	0.28	0.35	0.45	0.52	0.59	0.67	0.75	0.95	1.49
60	0.61	0.71	0.78	0.99	1.14	1.33	1.58	1.63	1.60	1.62	1.60	1.63	1.59
	0.11	0.13	0.18	0.22	0.28	0.36	0.45	0.52	0.58	0.67	0.74	0.94	1.43
65	0.64	0.74	0.80	1.02	1.16	1.35	1.60	1.74	1.72	1.75	1.75	1.75	1.74
	0.11	0.13	0.17	0.22	0.28	0.36	0.45	0.52	0.58	0.67	0.74	0.94	1.44
70	0.64	0.75	0.88	1.03	1.20	1.40	1.64	1.78	1.84	1.94	1.85	1.87	1.87
	0.11	0.13	0.17	0.22	0.28	0.36	0.45	0.52	0.58	0.67	0.74	0.94	1.44

ASD TR 61-191(II)

II-58

TABLE II B-32
RUBBER FORMING LIMITS
SHRINK FLANGES
J-1570 (SOLUTION TREATED)

Contour Radius R	Material Thickness (t)												
	.016	.020	.025	.032	.040	.050	.063	.071	.080	.090	.100	.125	.187
	Maximum and Minimum Flange Height Limits (h)												
5													
10	0.24	0.24	0.25										
	0.12	0.15	0.20										
15	0.35	0.36	0.36	0.36	0.36								
	0.12	0.15	0.19	0.24	0.31								
20	0.38	0.44	0.48	0.38	0.48	0.48							
	0.11	0.14	0.18	0.24	0.30	0.38							
25	0.42	0.48	0.54	0.61	0.60	0.60	0.60	0.60					
	0.11	0.14	0.18	0.24	0.30	0.38	0.48	0.55					
30	0.43	0.52	0.62	0.70	0.72	0.72	0.70	0.71	0.72	0.72			
	0.11	0.14	0.18	0.23	0.29	0.38	0.47	0.54	0.62	0.70			
35	0.46	0.54	0.63	0.74	0.88	0.85	0.88	0.85	0.88	0.86	0.85		
	0.11	0.14	0.18	0.23	0.29	0.37	0.47	0.53	0.61	0.69	0.78		
40	0.50	0.56	0.65	0.77	0.88	0.95	1.01	0.99	0.96	0.99	1.00		
	0.11	0.14	0.18	0.23	0.29	0.37	0.47	0.53	0.60	0.68	0.77		
45	0.51	0.60	0.70	0.80	0.92	1.10	1.13	1.14	1.12	1.17	1.15	1.12	
	0.11	0.14	0.18	0.23	0.29	0.37	0.47	0.53	0.60	0.68	0.76	0.98	
50	0.53	0.62	0.72	0.83	0.96	1.15	1.26	1.21	1.20	1.26	1.25	1.25	
	0.11	0.14	0.17	0.22	0.29	0.37	0.47	0.53	0.60	0.68	0.76	0.95	
55	0.54	0.64	0.73	0.86	1.00	1.18	1.39	1.35	1.36	1.35	1.38	1.37	
	0.11	0.14	0.17	0.22	0.28	0.36	0.46	0.53	0.60	0.68	0.75	0.95	
60	0.56	0.67	0.75	0.90	1.04	1.20	1.41	1.42	1.44	1.44	1.50	1.44	
	0.11	0.14	0.17	0.22	0.28	0.36	0.46	0.52	0.59	0.68	0.75	0.95	
65	0.58	0.68	0.77	0.90	1.01	1.25	1.45	1.56	1.60	1.62	1.60	1.62	1.59
	0.11	0.14	0.17	0.22	0.28	0.36	0.46	0.52	0.59	0.68	0.75	0.95	1.46
70	0.59	0.69	0.80	0.93	1.08	1.28	1.47	1.58	1.68	1.71	1.70	1.65	1.68
	0.11	0.14	0.17	0.22	0.28	0.36	0.46	0.52	0.59	0.68	0.75	0.95	1.46

ASD TR 61-191(II)

II-59

TABLE II B-33
 RUBBER FORMING LIMITS
 SHRINK FLANGES
 COLUMBIUM (10Mo-10T1)

Contour Radius R	Material Thickness (t)												
	.016	.020	.025	.032	.040	.050	.063	.071	.080	.090	.100	.125	.187
	Maximum and Minimum Flange Height Limits (h)												
5													
10													
15	0.22	0.21											
	0.14	0.17											
20	0.26	0.28	0.29	0.29									
	0.13	0.17	0.21	0.27									
25	0.28	0.32	0.35	0.35	0.36								
	0.13	0.17	0.21	0.27	0.34								
30	0.30	0.34	0.40	0.42	0.44								
	0.13	0.16	0.21	0.27	0.34								
35	0.31	0.36	0.43	0.50	0.52	0.50							
	0.13	0.16	0.21	0.27	0.34	0.43							
40	0.33	0.38	0.45	0.53	0.56	0.58	0.58						
	0.12	0.16	0.21	0.27	0.34	0.43	0.54						
45	0.34	0.40	0.46	0.54	0.64	0.65	0.66	0.67					
	0.13	0.16	0.21	0.27	0.34	0.42	0.54	0.61					
50	0.35	0.41	0.48	0.58	0.66	0.75	0.74	0.71	0.72				
	0.13	0.16	0.21	0.27	0.34	0.42	0.54	0.60	0.69				
55	0.37	0.42	0.49	0.58	0.68	0.80	0.82	0.78	0.80	0.79			
	0.13	0.16	0.20	0.26	0.33	0.42	0.53	0.60	0.68	0.77			
60	0.38	0.43	0.50	0.59	0.69	0.80	0.88	0.85	0.86	0.86			
	0.13	0.16	0.20	0.26	0.33	0.42	0.53	0.60	0.68	0.77			
65	0.38	0.44	0.51	0.61	0.72	0.84	0.95	0.95	0.96	0.95	0.93		
	0.12	0.16	0.19	0.26	0.32	0.41	0.52	0.60	0.68	0.77	0.86		
70	0.39	0.45	0.52	0.64	0.74	0.85	1.01	1.00	1.00	1.03	1.00		
	0.12	0.16	0.20	0.26	0.32	0.41	0.52	0.60	0.68	0.77	0.86		

ASD TR 61-191(II)

II-60

TABLE II B-34
 RUBBER FORMING LIMITS
 SHRINK FLANGES
 MOLYBDENUM ($\frac{5}{8}$ Ti)

Contour Radius R	Material Thickness (t)												
	.016	.020	.025	.032	.040	.050	.063	.071	.080	.090	.100	.125	.187
	Maximum and Minimum Flange Height Limits (h)												
5													
10													
15	0.17												
	0.14												
20	0.23	0.23	0.23										
	0.14	0.17	0.22										
25	0.29	0.28	0.29										
	0.13	0.17	0.22										
30	0.34	0.34	0.34	0.35									
	0.13	0.17	0.22	0.28									
35	0.41	0.41	0.41	0.41	0.40								
	0.13	0.17	0.21	0.28	0.35								
40	0.45	0.46	0.46	0.47	0.46	0.46							
	0.13	0.17	0.21	0.28	0.35	0.44							
45	0.47	0.53	0.53	0.53	0.52	0.58							
	0.13	0.17	0.21	0.27	0.35	0.44							
50	0.49	0.57	0.58	0.59	0.58	0.58	0.58						
	0.13	0.17	0.21	0.27	0.34	0.44	0.55						
55	0.50	0.58	0.63	0.64	0.64	0.63	0.63						
	0.13	0.16	0.21	0.27	0.34	0.43	0.55						
60	0.51	0.60	0.70	0.70	0.69	0.69	0.69	0.68					
	0.13	0.16	0.21	0.27	0.34	0.43	0.55	0.62					
65	0.53	0.62	0.71	0.75	0.75	0.75	0.74	0.73	0.74				
	0.13	0.16	0.21	0.27	0.34	0.43	0.55	0.62	0.71				
70	0.54	0.62	0.73	0.80	0.78	0.79	0.79	0.80	0.79				
	0.13	0.16	0.21	0.27	0.34	0.43	0.55	0.62	0.70				

ASD TR 61-191(TI)

II-61

SECTION III
LINEAR CONTOURING OF SECTIONS
A. LINEAR STRETCH FORMING
B. LINEAR ROLL FORMING

LINEAR STRETCH FORMING

Description of Process

Linear stretch forming is a process whereby a brake formed or extruded part is changed from a linear configuration to a contoured configuration by utilizing a special stretch press machine having a fixed die holder and retractable traveling stretch jaws.

The process of linear stretch forming an acceptable part consists of changing a linear configuration to a contoured configuration without destroying the integrity of the original cross section. Theoretically, this is achieved by employing an optimum initial tension which will place the neutral axis at the inner fiber of the part when forming is completed. See Figure III A-1 for illustration.

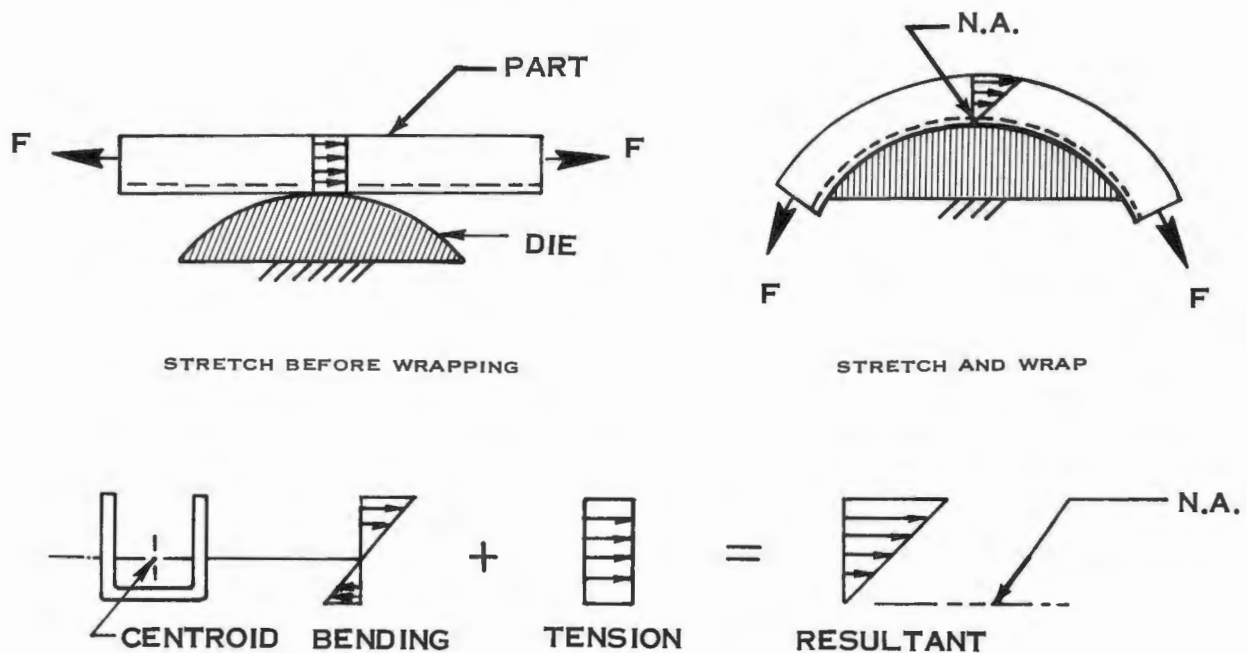

FIGURE III A-1

LINEAR STRETCH FORM PROCESS

Definition of Part Shape
and Geometric Variables

The formability limits presented herein are valid for the sheet metal configuration illustrated in Figures III A-2 through Figure III A-6.

Symbol designations for these configurations are listed below:

- t = material thickness
- D = web or flange width
- h = section height of part
- R = inside part radius
- R_d = outside part radius
- R_c = contour radius (the R or R_d to be fastened to another part)

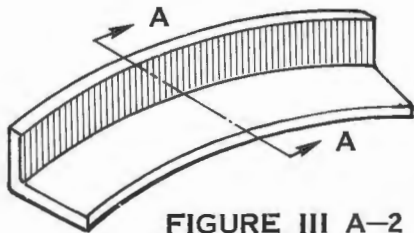

FIGURE III A-2
HEEL-OUT ANGLE

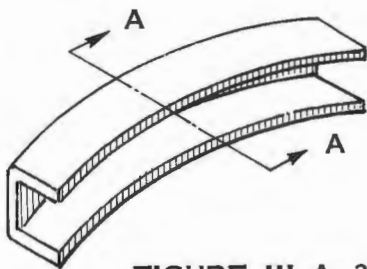
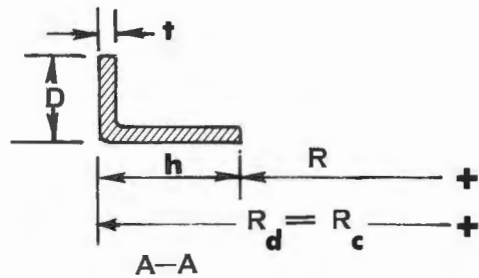
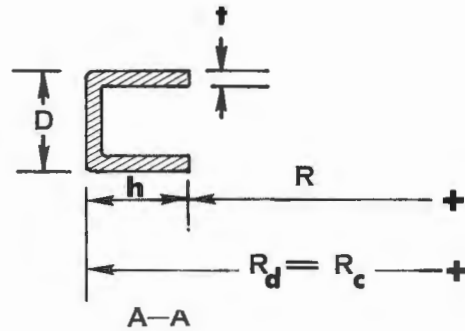

FIGURE III A-3
HEEL-OUT CHANNEL



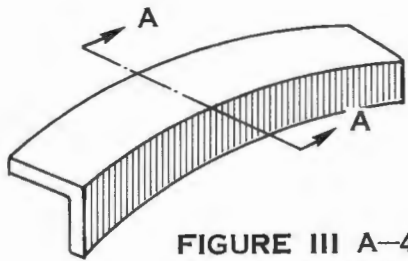

FIGURE III A-4
HEEL-IN ANGLE

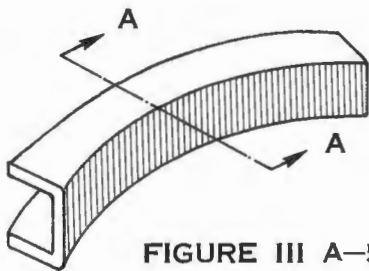
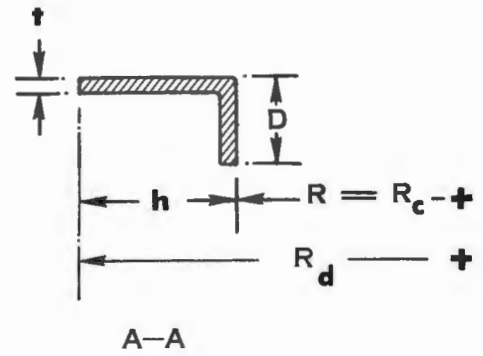

FIGURE III A-5
HEEL-IN CHANNEL

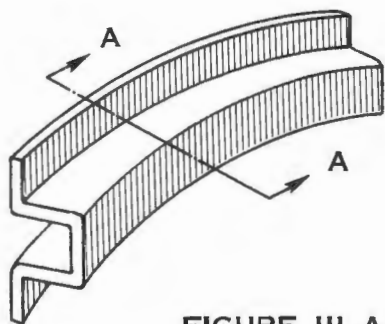
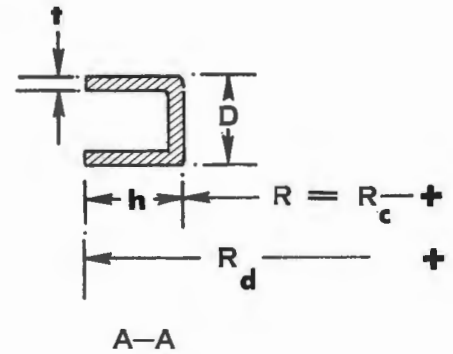
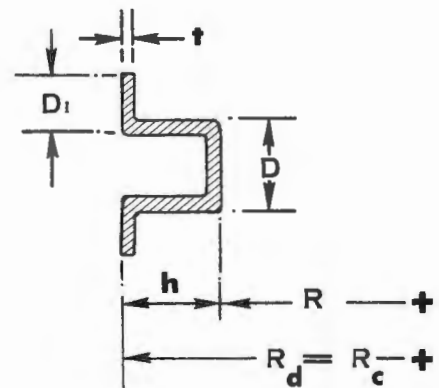

FIGURE III A-6
HEEL-IN HAT SECTION



Three distinct classes of formability limits are generated by the five types of configurations. They are heel-out angles and channels, heel-in angles and channels, and heel-in hat sections.

Predictability Equations

The following predictability equations define the formability limits for the three geometric classes:

Class 1: Heel-out angles and channels

(Elastic buckling equation)

$$\frac{h}{R} = \frac{E}{S_{ty}} \left[\frac{0.4225}{(h/t)^2} \right]$$

Equation I

(Inflection line equation)

$$\frac{h}{R} = 0.01107 \sqrt{\frac{h}{t}}$$

Equation II

(Elasto-plastic buckling equation)

$$\frac{h}{t} = \left[38.2 \frac{E}{S_{ty}} \right]^{\frac{2}{5}}$$

Equation III

(Splitting equation)

$$\frac{h}{R} = -0.836 \left[\epsilon_{2.0} + 0.045 \right] \left[\log \left(0.0025 \frac{h}{t} \right) \right]$$

Equation IV

Class 2: Heel-in angles and channels

(Elastic buckling equation)

$$\boxed{\frac{h}{R} = \frac{E}{S_{ty}} \left[\frac{0.81}{(h/t)^2} \right]}$$

Equation V

(Splitting equation)

$$\boxed{\frac{h}{R} = -1.02 \left[\epsilon_{2.0} + 0.05597 \right] \left[\log \left(0.0033 \frac{h}{t} \right) \right]}$$

Equation VI

Class 3: Heel-in hat sections

(Elastic buckling equation)

$$\boxed{\frac{h}{R} = \frac{E}{S_{ty}} \left[\frac{0.4225}{(h/t)^2} \right]}$$

Equation VII

(Splitting equation)

$$\boxed{\frac{h}{R} = -0.583 \left[\epsilon_{2.0} + 0.0644 \right] \left[\log \left(0.0025 \frac{h}{t} \right) \right]}$$

Equation VIII

The geometric variables h, R and t are defined in the part geometry section and the mechanical property variables are defined in the list of symbols. E and S_{ty} were taken from standard longitudinal tension tests. When solving the various equations for h/R values, substitute arbitrarily chosen h/t values as required.

Formability limits as defined by the predictability equations are for materials having minimum mechanical property values because the curves from which the equations were developed were constructed to a minimum value criterion.

See Figures III A-7 and III A-8 for schematics of equation application.

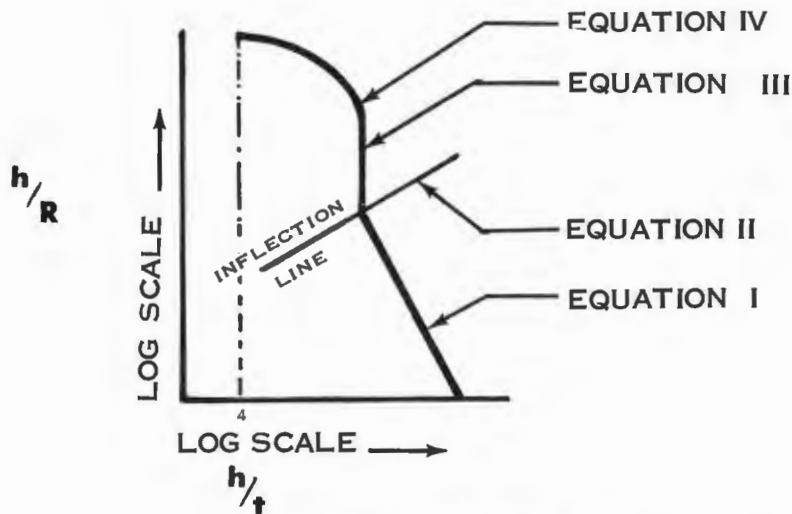

FIGURE III A-7
EQUATION APPLICATION FOR CLASS I
FORMABILITY LIMIT CURVES

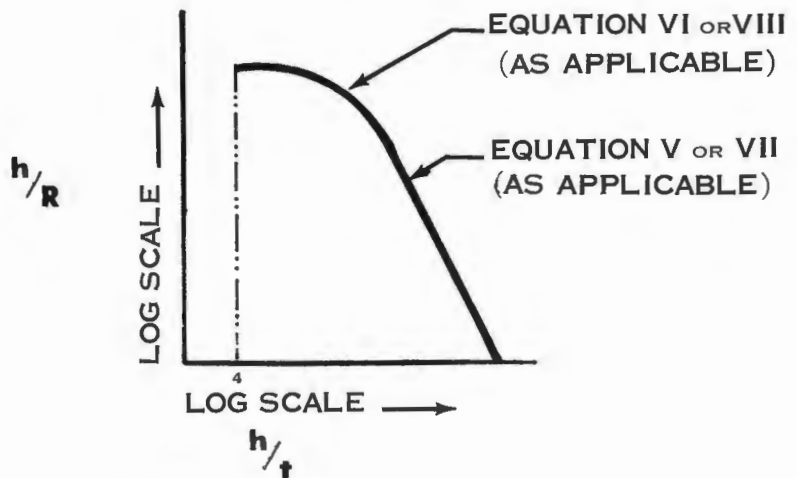

FIGURE III A-8
EQUATION APPLICATION FOR CLASS 2
AND CLASS 3 FORMABILITY LIMIT CURVES

Composite Graphs

The composite graphs for the three formability classes (See Graphs III A-1 through III A-3) were constructed from the appropriate formability equations as illustrated in Figures III A-7 and III A-8.

When using the appropriate equation for Class 1 and Class 3 formability limit curves it is necessary to convert R_c to R .

It may be of interest to note that the geometric variables determine the configuration of the curves and that the mechanical property variables position the curves.

These curves may be used to determine if a specific part will form satisfactorily by plotting an h/R , h/t point on the appropriate formability graph. If the point falls within the formability envelope as illustrated in Figure III A-9, the part can be formed satisfactorily. If the point falls outside the formability envelope as shown in Figure III A-10, the part will be defective.

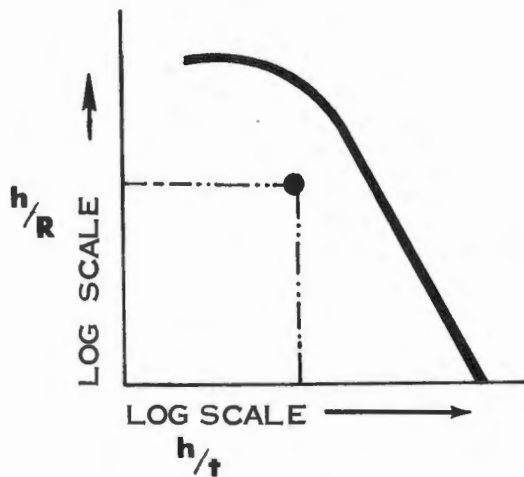

FIGURE III A-9
SATISFACTORY FORMABILITY

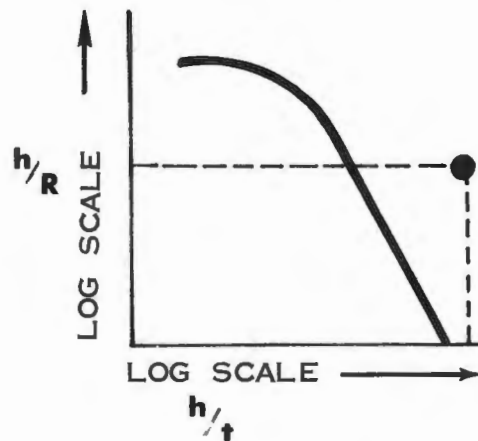

FIGURE III A-10
UNSATISFACTORY FORMABILITY

Formability limit curves may also be constructed on Cartesian graph paper in such a manner that section height (h) and contour radius (R_c) can be read directly from the graph. The procedure is:

Arbitrarily pick a point on the log type formability curve as illustrated in Figure III A-11 and express this point in h/R and h/t values.

Next, use a specific metal thickness (t), solve for (h) and (R_c) and plot the point on the Cartesian type graph as shown in Figure III A-12. (Note that $R_c = R$ for Class 2 configuration and $R_c = R+h$ for Class 1 and Class 3 configurations.)

Repeat the above procedure as required and draw a formability limit curve through the points.

See Graph III A-4 for a Cartesian type composite formability limit curve for heel-in angles and channels made from various thicknesses of 2024-0 aluminum.

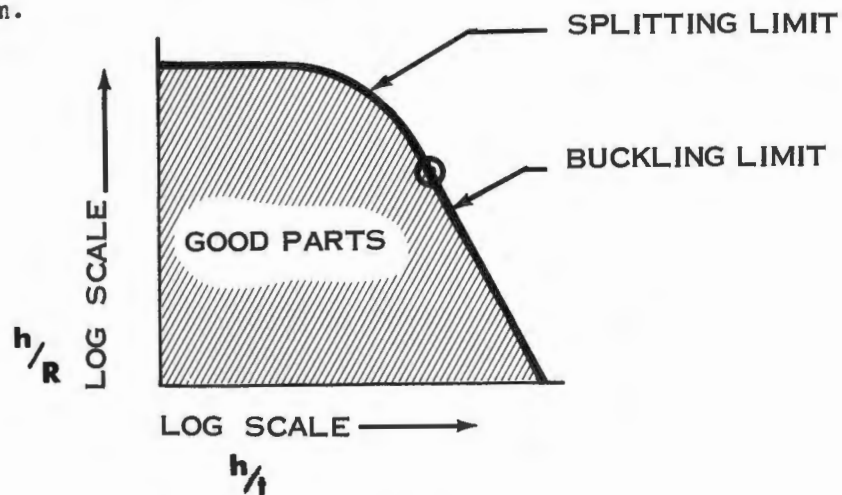

FIGURE III A-11
LOG TYPE FORMABILITY
LIMIT CURVE

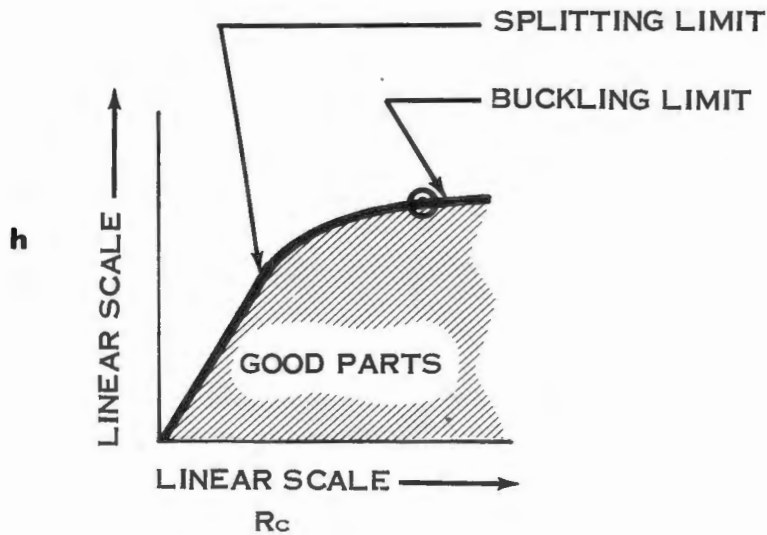

FIGURE III A-12

CARTESIAN TYPE FORMABILITY
LIMIT CURVE

The absolute forming limits as presented in the design tables are practical unless the mechanical properties for a material are abnormally poor because the formability curves, which define the absolute limits, are based on minimum mechanical property values. (See Figure III A-13).

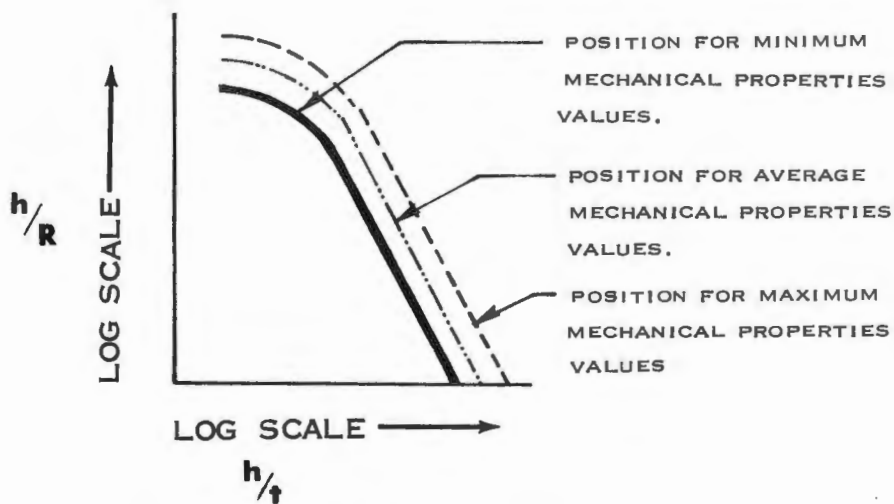

FIGURE III A-13

EFFECT OF MECHANICAL PROPERTY
VARIATION ON FORMABILITY

In order to approach the absolute forming limits indicated by the formability limit curves for Class 2 and Class 3 part geometries, it is mandatory that the bend radii at the inner fiber be kept to a minimum because large bend radii promote "springback" and column collapse as illustrated in Figures III A-14 and III A-15.

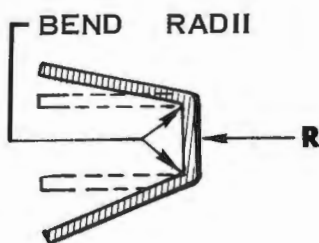

FIGURE III A-14
SPRING BACK DUE TO
LARGE BEND RADII

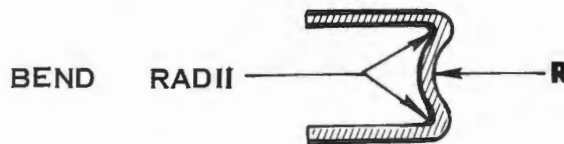

FIGURE III A-15
COLUMN COLLAPSE DUE
TO LARGE BEND RADII

Notch sensitivity will also prevent a part from approaching the absolute forming limit. It is imperative that the edges of parts located at the outer fiber be properly deburred. In some instances deburring will not remove the shear cracks and splitting will result. In cases of this type the part blank should be sawed instead of sheared.

The absolute limits as defined by the design tables may be extended somewhat by using the following procedure:

Lubrication: When a part is being wrapped it has a tendency to stick to the die upon contact. Even though there are untrapped dislocations (potential elongation) left in the part area which is in contact with the die, this potential is not available

because of friction between the die and the part. The use of lubricants will reduce this friction and extend the formability limit somewhat. When the limit curves were being established the use of lubricants were discontinued because parts formed on large radii dies having small segment angles were suggesting formability limits which could not be maintained using the same die radii with large segment angles.

Multiple Process: The absolute limit may be exceeded in the buckling area but the usual result will be a buckled part. It may be possible to remove the buckle by hand working, shrinking, creep forming at elevated temperature, heat treating and aging prior to re-stretch and wrap, etc.

Splitting limits may also be exceeded slightly by wrapping at a reduced stress; however, the part will require some type of rework.

Manipulation of Stress During Wrapping: As a part is being wrapped the physical properties change somewhat due to work hardening. For some materials, particularly those having a face centered lattice structure, a gradual increase in stress as the part is being wrapped will improve formability .

Strain Rate: The rate of wrapping a part has considerable influence on formability limits, particularly for materials having a body centered or hexagonal lattice structure. Ductile to brittle transition ranges for refractory materials can be altered by rate of strain. Formability limit curves will predict formability more accurately when the pertinent physical property values for a material is established at the same strain rate that will be used to form a part.

Redistribution of Stresses: Redistribution of stresses will increase formability limits slightly in the buckling area where relatively large die radii are used. This is accomplished by unwrapping a buckled part under stress with the stretch press, stressing the part still more and rewrapping the part.

Elevated Temperature Forming: Elevated temperature forming may or may not increase formability limits. Pertinent physical property values taken from standard tensile tests made at elevated temperature can be compared with ambient temperature properties to determine if there is a probability of increasing formability.

Even though elevated temperature tensile tests for a specific material indicates the probability of extended formability, an increase in necking at elevated temperature may prevent this extension.

The optimum forming temperature for a given material must be determined before a valid elevated temperature formability limit curve can be constructed.

GRAPH III A-1

LINEAR STRETCH COMPOSITE GRAPH
HEEL-OUT ANGLES AND CHANNELS

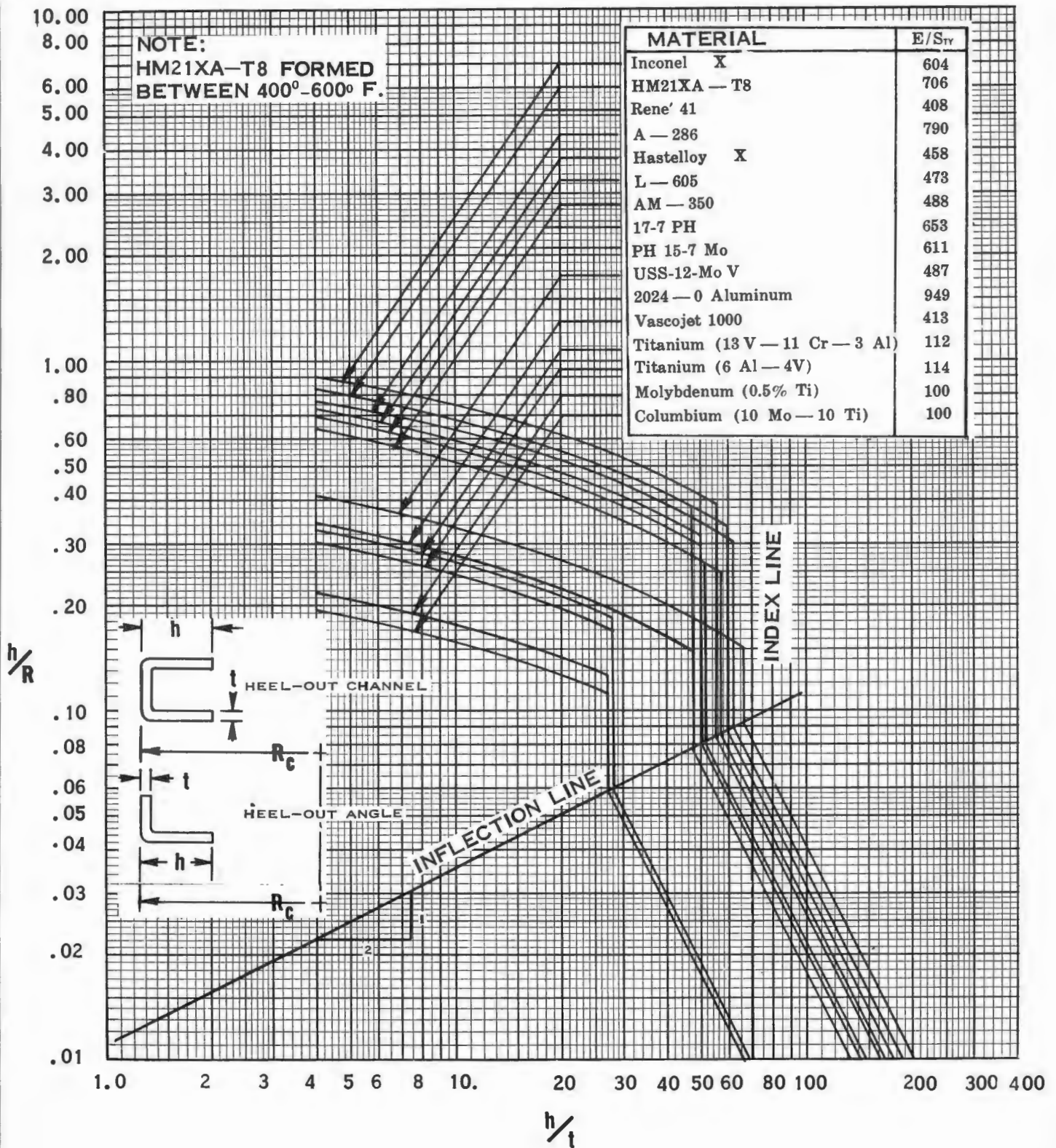

GRAPH III A-2

LINEAR STRETCH COMPOSITE GRAPH
HEEL-IN ANGLES AND CHANNELS

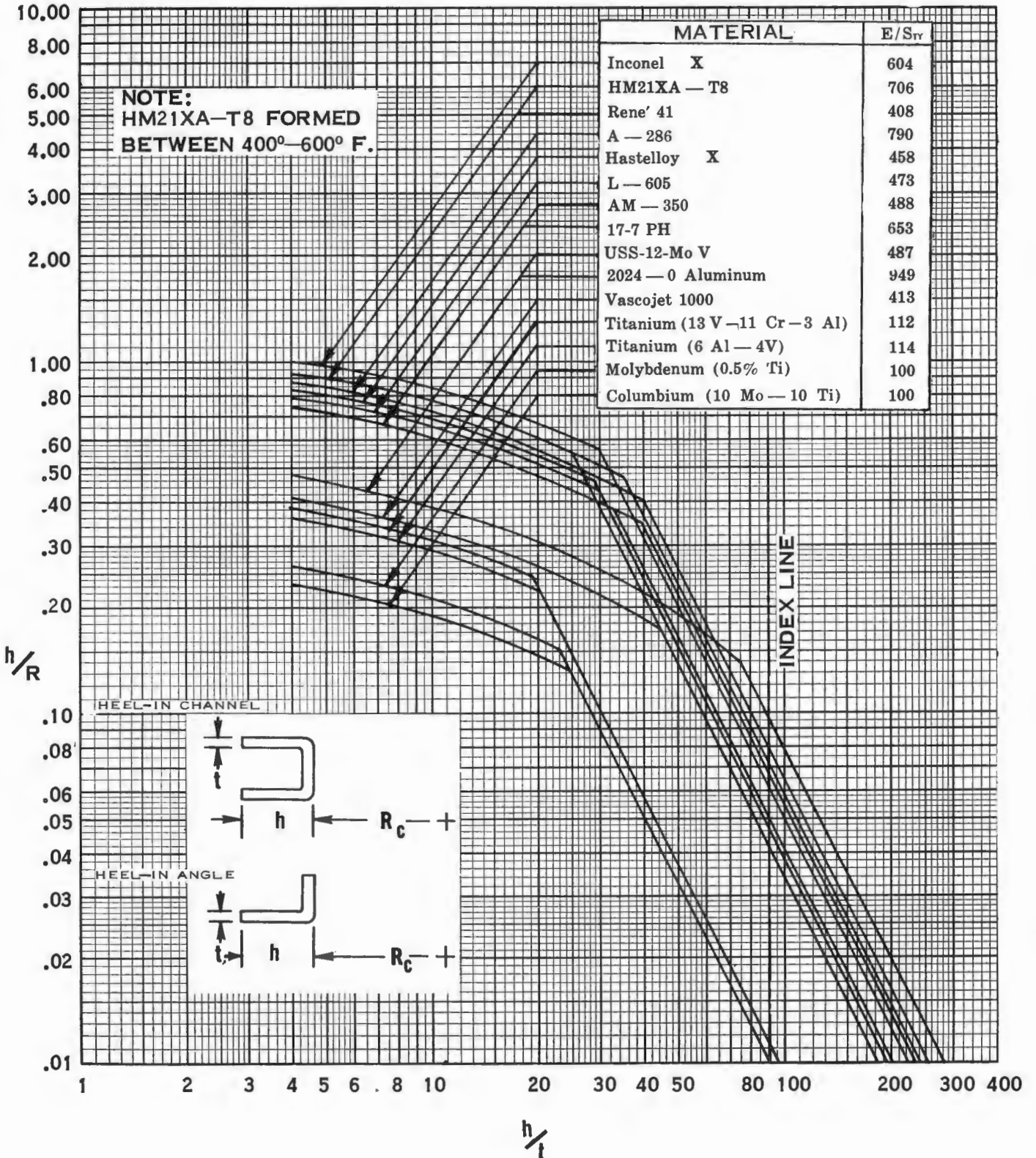

GRAPH III A-3

LINEAR STRETCH COMPOSITE GRAPH
HEEL-IN HAT SECTIONS

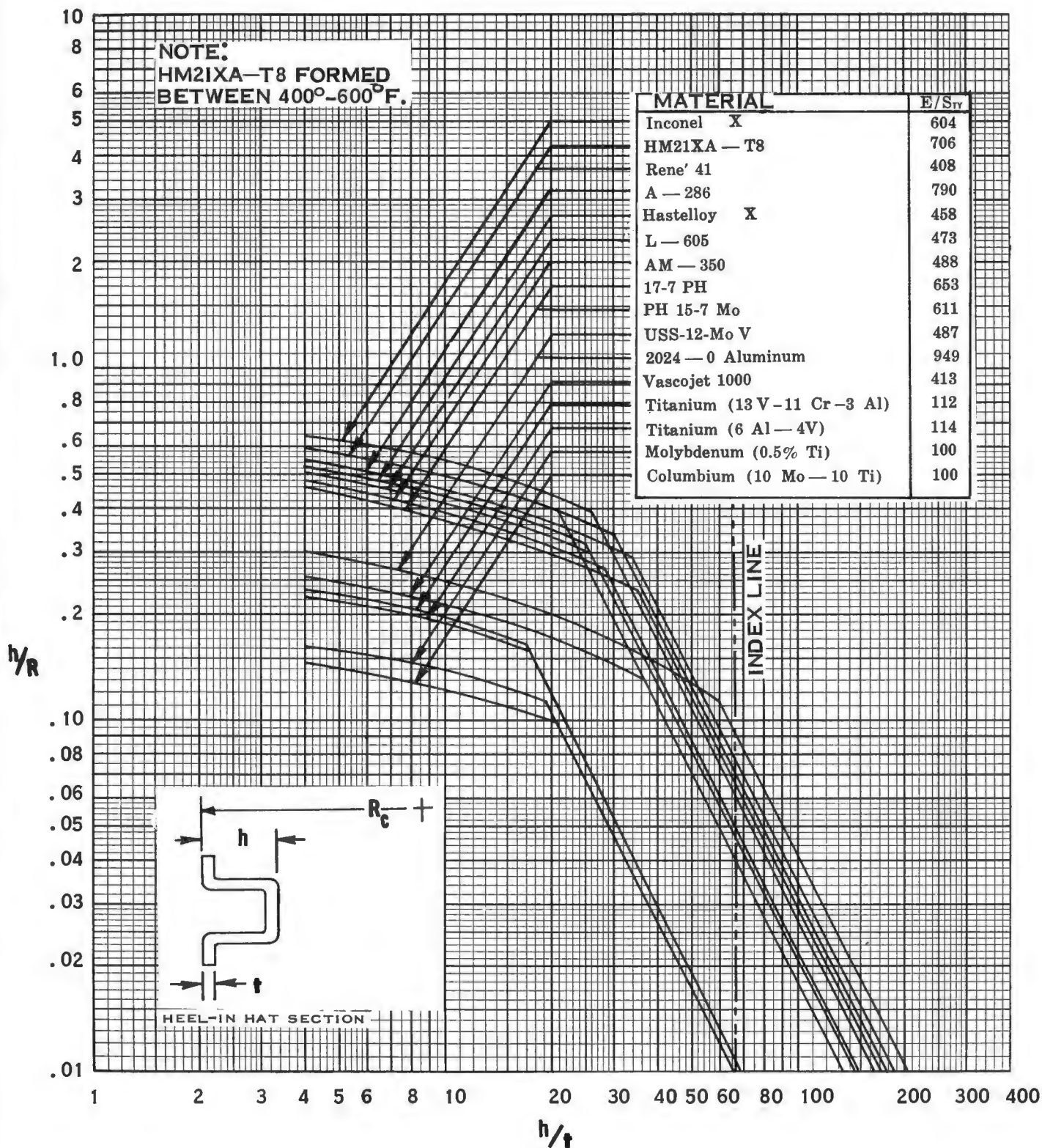

GRAPH III A-4

LINEAR STRETCH FORMABILITY LIMITS
HEEL-IN ANGLES AND CHANNELS

2024-0 Aluminum

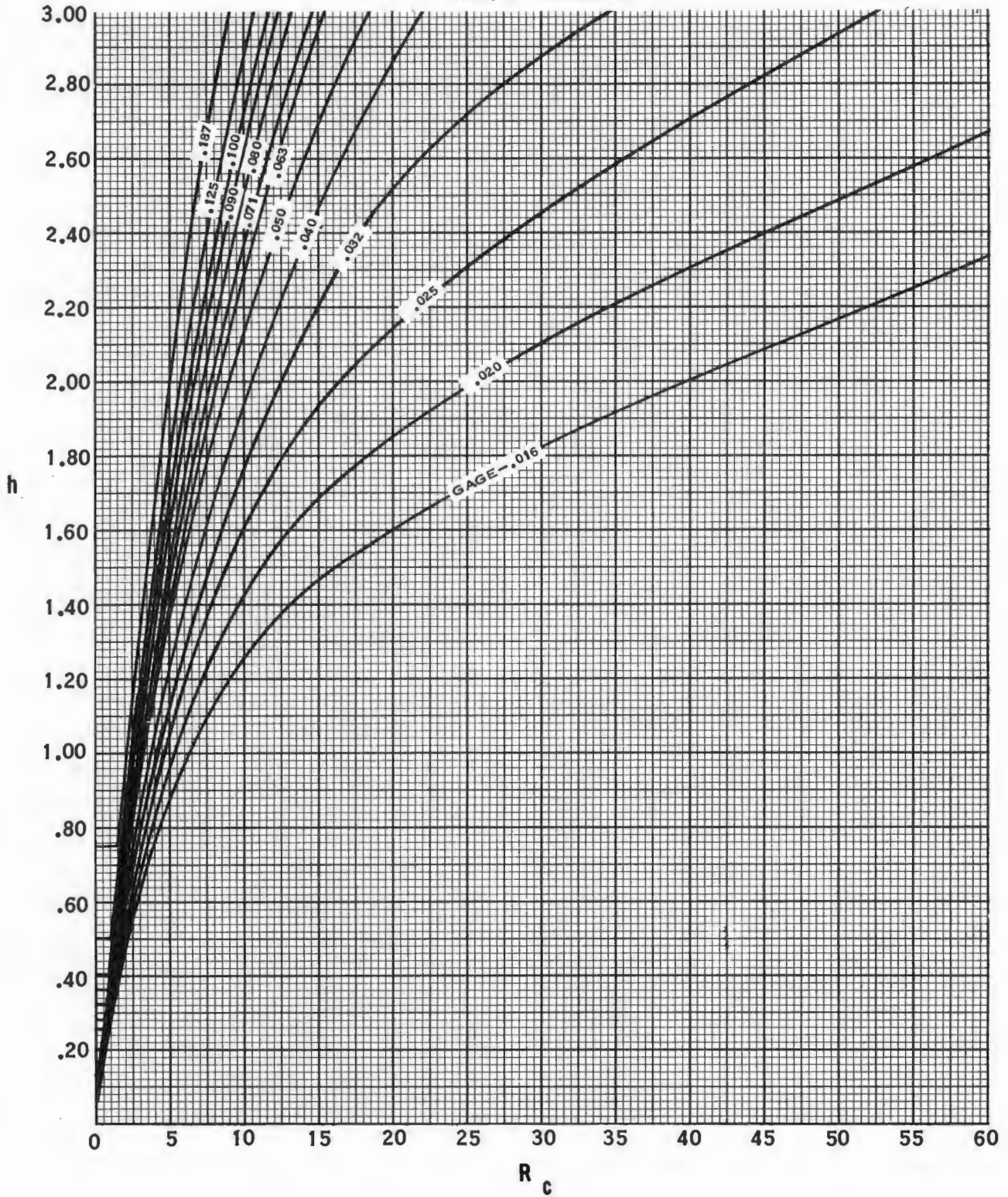

Design Tables

The following design tables are presented as a guide for determining design limits for heel-out angles and channels, heel-in angles and channels, and heel-in hat sections.

These tables are constructed so that various contour radii oppose various material thicknesses. The value at the intersection for a specific contour radius and a specific material thickness denotes the maximum section height that can be formed.

Section height calculations were discontinued after reaching the first three inch value for a given contour radius and a given material thickness in order to establish a functional limit.

The heavy line drawn through the section height limits indicates whether a part having a specific R_c , t and h is approaching a splitting or a buckling limit. Parts having a section height value above or to the right of the heavy line are approaching the splitting limit.

Design tables for HM21XA-T8 at ambient temperature were deleted because brittleness caused excess scrap; however, the design table for this material at elevated temperature is included.

Design values for the other materials which were formed at elevated temperatures were deleted because extension of forming limits in the buckling region were trivial and reduction of limits occurred in the splitting region.

Estimated E/S_{ty} values were used to establish the buckling limits for the molybdenum and columbium alloys because the stretch press used to

form these parts could not be operated to produce the same strain rate at which the tensile specimens were pulled.

Beryllium and tungsten were deleted from the design tables because special clamping methods must be developed to adapt linear stretch forming to these materials.

TABLES III A-1 THROUGH III A-17 LINEAR STRETCH FORMABILITY LIMITS
HEEL-OUT ANGLES AND CHANNELS

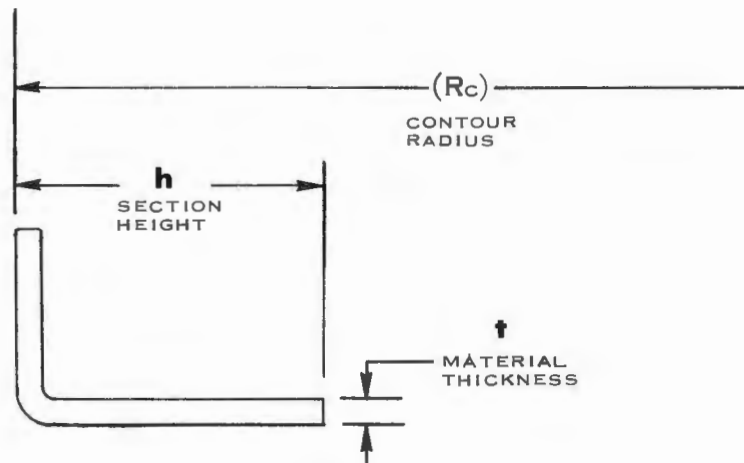

HEEL-OUT ANGLE
FIGURE IIIA-16

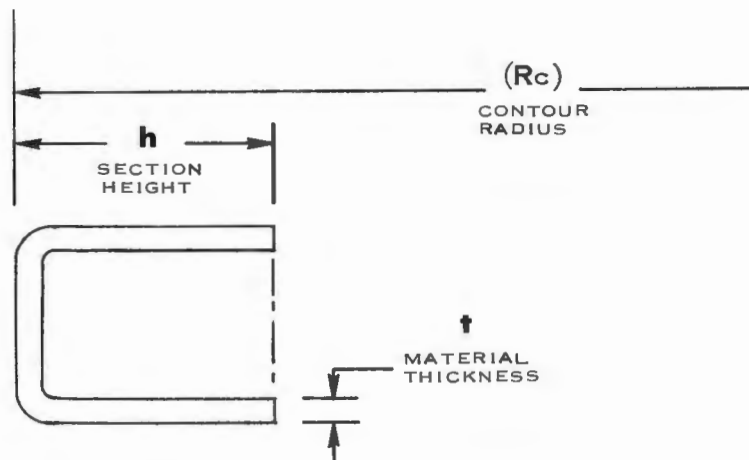

HEEL-OUT CHANNEL
FIGURE IIIA-17

TABLE III A-2
 LINEAR STRETCH FORMING LIMITS
 HEEL-OUT ANGLES & CHANNELS
 2024-O ALUMINUM

Contour Radius R _c	Material Thickness (t)												
	.016	.020	.025	.032	.040	.050	.063	.071	.080	.090	.100	.125	.187
	Section Height Limits (h)												
5	.77	.82	.87	.93	1.00	1.05	1.10	1.12	1.14	1.17	1.19	1.25	1.35
10	1.04	1.30	1.37	1.49	1.60	1.70	1.81	1.88	1.94	2.00	2.05	2.12	2.28
15	1.12	1.30	1.62	1.92	2.12	2.30	2.47	2.53	2.64	2.78	3.02		
20	1.25	1.45	1.65	2.08	2.60	2.80	3.02						
25	1.36	1.55	1.80	2.08	2.60	3.25							
30	1.41	1.64	1.87	2.24	2.60	3.25							
35	1.50	1.74	2.00	2.37	2.68	3.25							
40	1.60	1.85	2.12	2.50	2.90	3.25							
45	1.63	1.90	2.19	2.59	3.01								
50	1.70	1.96	2.31	2.66	3.08								
55	1.78	2.04	2.37	2.75	3.24								
60	1.80	2.10	2.42	2.85	3.30								
65	1.89	2.20	2.52	2.96	3.44								
70	1.92	2.21	2.55	2.99	3.50								

ASD TR 61-191(II)

III-21

TABLE III A-4
 LINEAR STRETCH FORMING LIMITS
 HEEL-OUT ANGLES & CHANNELS
 PH 15-7 Mo
 (CONDITION A)

Contour Radius R_c	Material Thickness (t)												
	.016	.020	.025	.032	.040	.050	.063	.071	.080	.090	.100	.125	.187
	Section Height Limits (h)												
5	.89	1.04	1.12	1.22	1.28	1.35	1.42	1.46	1.48	1.51	1.56	1.62	1.74
10	.89	1.11	1.39	1.78	2.04	2.21	2.39	2.48	2.54	2.61	2.70	2.81	3.07
15	.98	1.12	1.39	1.78	2.22	2.77	3.12						
20	1.09	1.26	1.45	1.78	2.22	2.77	3.49						
25	1.15	1.34	1.56	1.82	2.22	2.77	3.49						
30	1.25	1.44	1.67	1.95	2.26	2.77	3.49						
35	1.30	1.50	1.72	2.05	2.36	2.77	3.49						
40	1.38	1.58	1.85	2.18	2.50	2.89	3.49						
45	1.42	1.64	1.92	2.24	2.60	3.00							
50	1.47	1.72	1.97	2.34	2.68	3.10							
55	1.52	1.76	2.02	2.40	2.80	3.25							
60	1.58	1.82	2.10	2.50	2.88	3.32							
65	1.62	1.88	2.20	2.56	2.98	3.43							
70	1.63	1.90	2.22	2.61	3.04								

ASD TR 61-191(II)

III-23

TABLE III A-5
 LINEAR STRETCH FORMING LIMITS
 HEEL-OUT ANGLES & CHANNELS
 AM-350
 (ANNEALED)

Contour Radius R_c	Material Thickness (t)												
	.016	.020	.025	.032	.040	.050	.063	.071	.080	.090	.100	.125	.187
	Section Height Limits (h)												
5	.81	1.01	1.16	1.28	1.35	1.41	1.47	1.51	1.54	1.57	1.61	1.69	1.80
10	.81	1.01	1.26	1.62	2.02	2.30	2.52	2.57	2.66	2.72	2.81	2.94	3.22
15	.91	1.04	1.26	1.62	2.02	2.52	3.18						
20	1.02	1.16	1.33	1.62	2.02	2.52	3.18						
25	1.08	1.25	1.45	1.69	2.02	2.52	3.18						
30	1.15	1.34	1.55	1.80	2.02	2.52	3.18						
35	1.20	1.40	1.62	1.92	2.20	2.52	3.18						
40	1.28	1.46	1.70	2.00	2.32	2.65	3.18						
45	1.32	1.54	1.79	2.08	2.44	2.79	3.21						
50	1.38	1.60	1.84	2.14	2.50	2.90	3.40						
55	1.41	1.64	1.87	2.24	2.60	3.01							
60	1.47	1.70	1.95	2.30	2.68	3.10							
65	1.52	1.73	2.00	2.37	2.72	3.17							
70	1.54	1.79	2.05	2.40	2.80	3.25							

TABLE III A-6
 LINEAR STRETCH FORMING LIMITS
 HEEL-OUT ANGLES & CHANNELS
 A-286
 (SOLUTION TREATED)

Contour Radius R_c	Material Thickness (t)												
	.016	.020	.025	.032	.040	.050	.063	.071	.080	.090	.100	.125	.187
	Section Height Limits (h)												
5	.98	1.14	1.25	1.34	1.41	1.50	1.57	1.60	1.64	1.66	1.70	1.79	1.91
10	.98	1.22	1.52	1.95	2.25	2.43	2.69	2.71	2.78	2.90	3.00		
15	1.08	1.22	1.52	1.95	2.44	3.05							
20	1.17	1.36	1.55	1.95	2.44	3.05							
25	1.26	1.46	1.70	1.98	2.44	3.05							
30	1.31	1.54	1.80	2.13	2.44	3.05							
35	1.40	1.64	1.87	2.24	2.56	3.05							
40	1.48	1.72	1.98	2.34	2.71	3.09							
45	1.54	1.78	2.06	2.43	2.80	3.25							
50	1.60	1.85	2.12	2.50	2.88	3.35							
55	1.63	1.90	2.20	2.59	3.02								
60	1.70	1.96	2.27	2.66	3.10								
65	1.74	2.02	2.35	2.75	3.20								
70	1.79	2.10	2.40	2.82	3.28								

ASD TR 61-191(II)

III-25

TABLE III A-7
 LINEAR STRETCH FORMING LIMITS
 HEEL-OUT ANGLES & CHANNELS
 USS-12-MoV
 (ANNEALED)

Contour Radius R _c	Material Thickness (t)												
	.016	.020	.025	.032	.040	.050	.063	.071	.080	.090	.100	.125	.187
	Section Height Limits (h)												
5	.77	.81	.87	.94	1.00	1.05	1.10	1.13	1.14	1.17	1.20	1.25	1.31
10	.82	1.02	1.27	1.54	1.62	1.72	1.86	1.95	2.00	2.04	2.10	2.19	2.37
15	.91	1.05	1.27	1.63	2.04	2.30	2.46	2.56	2.68	2.73	2.80	3.00	
20	1.01	1.16	1.35	1.63	2.04	2.55	3.02						
25	1.09	1.25	1.45	1.73	2.04	2.55	3.02						
30	1.15	1.34	1.55	1.82	2.12	2.55	3.02						
35	1.20	1.40	1.62	1.92	2.20	2.55	3.02						
40	1.28	1.46	1.70	2.02	2.32	2.65	3.02						
45	1.31	1.52	1.77	2.08	2.40	2.77	3.28						
50	1.37	1.60	1.85	2.18	2.52	2.90	3.40						
55	1.41	1.64	1.89	2.22	2.60	3.00							
60	1.44	1.68	1.95	2.30	2.68	3.07							
65	1.50	1.74	2.02	2.37	2.76	3.20							
70	1.53	1.76	2.05	2.40	2.80	3.25							

TABLE III A-8
 LINEAR STRETCH FORMING LIMITS
 HEEL-OUT ANGLES & CHANNELS
 TITANIUM (6Al-4V)
 (MILL ANNEALED)

Contour Radius R_c	Material Thickness (t)												
	.016	.020	.025	.032	.040	.050	.063	.071	.080	.090	.100	.125	.187
	Section Height Limits (h)												
5	.43	.54	.67	.77	.87	.88	.91	.94	.95	.97	.99	1.03	1.10
10	.49	.56	.70	.90	1.12	1.40	1.51	1.58	1.62	1.66	1.70	1.77	1.96
15	.56	.64	.75	.90	1.12	1.40	1.76	1.99	2.20	2.27	2.32	2.44	2.71
20	.63	.72	.83	.97	1.12	1.40	1.76	1.99	2.24	2.52	2.80	3.12	
25	.67	.77	.90	1.06	1.21	1.40	1.76	1.99	2.24	2.52	2.80	3.50	
30	.71	.82	.95	1.13	1.29	1.50	1.76	1.99	2.24	2.52	2.80	3.50	
35	.74	.87	1.00	1.18	1.36	1.59	1.84	1.99	2.24	2.52	2.80	3.50	
40	.78	.92	1.05	1.25	1.44	1.67	1.94	2.07	2.24	2.52	2.80	3.50	
45	.80	.94	1.10	1.28	1.49	1.71	2.02	2.14	2.34	2.52	2.80	3.50	
50	.84	.98	1.13	1.34	1.53	1.79	2.07	2.26	2.46	2.63	2.80	3.50	
55	.87	1.00	1.17	1.37	1.60	1.85	2.15	2.34	2.54	2.72	2.92	3.50	
60	.90	1.04	1.21	1.41	1.66	1.91	2.25	2.41	2.62	2.85	3.00		
65	.93	1.06	1.25	1.47	1.68	1.96	2.28	2.47	2.68	2.88	3.05		
70	.96	1.09	1.26	1.50	1.75	2.01	2.36	2.53	2.74	3.00			

TABLE III A-9
 LINEAR STRETCH FORMING LIMITS
 HEEL-OUT ANGLES AND CHANNELS
 TITANIUM (13V-11 Cr-3Al)
 (SOLUTION TREATED)

Contour Radius R_c	Material Thickness (t)												
	.016	.020	.025	.032	.040	.050	.063	.071	.080	.090	.100	.125	.187
	Section Height Limits (h)												
5	.45	.56	.70	.82	.88	.91	.96	.99	1.00	1.01	1.01	1.09	1.16
10	.48	.56	.70	.90	1.12	1.40	1.62	1.69	1.72	1.77	1.80	1.89	2.08
15	.56	.65	.75	.90	1.12	1.40	1.76	1.99	2.24	2.38	2.50	2.62	2.86
20	.62	.72	.79	.96	1.12	1.40	1.76	1.99	2.24	2.38	2.80	3.25	
25	.67	.78	.90	1.06	1.23	1.40	1.76	1.99	2.24	2.38	2.80	3.50	
30	.71	.82	.95	1.13	1.29	1.50	1.76	1.99	2.24	2.38	2.80	3.50	
35	.74	.86	1.00	1.17	1.36	1.58	1.83	1.99	2.24	2.38	2.80	3.50	
40	.78	.90	1.05	1.23	1.44	1.65	1.95	2.06	2.24	2.38	2.80	3.50	
45	.80	.92	1.08	1.28	1.46	1.70	2.02	2.13	2.32	2.38	2.80	3.50	
50	.85	.96	1.14	1.37	1.55	1.80	2.08	2.27	2.41	2.64	2.82	3.50	
55	.86	1.00	1.16	1.38	1.60	1.83	2.14	2.33	2.54	2.70	2.90	3.50	
60	.90	1.04	1.20	1.41	1.64	1.90	2.24	2.41	2.58	2.79	3.00		
65	.91	1.06	1.23	1.45	1.68	1.95	2.27	2.43	2.67	2.88	3.02		
70	.94	1.08	1.25	1.48	1.72	2.00	2.31	2.50	2.72	2.95	3.12		

TABLE III A-10
 LINEAR STRETCH FORMING LIMITS
 HEEL-OUT ANGLES & CHANNELS
 VASCOJET 1000 (H-11)
 (ANNEALED)

Contour Radius R_c	Material Thickness (t)												
	.016	.020	.025	.032	.040	.050	.063	.071	.080	.090	.100	.125	.187
	Section Height Limits (h)												
5	.70	.73	.80	.85	.92	.95	1.00	1.03	1.04	1.05	1.09	1.12	1.21
10	.77	.96	1.20	1.38	1.44	1.55	1.70	1.74	1.80	1.84	1.90	1.94	2.11
15	.86	.98	1.20	1.54	1.92	2.05	2.20	2.24	2.32	2.43	2.50	2.62	2.90
20	.94	1.10	1.25	1.54	1.92	2.40	2.65	2.80	2.88	3.06			
25	1.02	1.18	1.36	1.60	1.92	2.40	3.02						
30	1.09	1.26	1.45	1.73	1.96	2.40	3.02						
35	1.14	1.32	1.52	1.79	2.08	2.40	3.02						
40	1.20	1.38	1.60	1.89	2.16	2.50	3.02						
45	1.25	1.44	1.67	1.95	2.28	2.60	3.02						
50	1.28	1.50	1.74	2.05	2.36	2.75	3.21						
55	1.33	1.54	1.77	2.08	2.44	2.82	3.28						
60	1.36	1.60	1.85	2.18	2.52	2.90	3.40						
65	1.42	1.64	1.92	2.24	2.60	3.00							
70	1.44	1.68	1.95	2.27	2.64	3.10							

ASD TR 61-191(II)

III-29

TABLE III A-11
 LINEAR STRETCH FORMING LIMITS
 HEEL-OUT ANGLES & CHANNELS
 RENE '41
 (SOLUTION TREATED)

Contour Radius R_c	Material Thickness (t)												
	.016	.020	.025	.032	.040	.050	.063	.071	.080	.090	.100	.125	.187
	Section Height Limits (h)												
5	.75	.94	1.17	1.38	1.44	1.51	1.61	1.64	1.68	1.71	1.73	1.85	1.96
10	.75	.94	1.17	1.50	1.88	2.35	2.75	2.84	2.88	3.04			
15	.86	.98	1.17	1.50	1.88	2.35	2.96	3.34					
20	.94	1.10	1.25	1.50	1.88	2.35	2.96	3.34					
25	1.01	1.17	1.36	1.60	1.88	2.35	2.96	3.34					
30	1.07	1.24	1.45	1.70	1.96	2.35	2.96	3.34					
35	1.14	1.32	1.52	1.79	2.08	2.40	2.96	3.34					
40	1.20	1.37	1.60	1.88	2.17	2.53	2.96	3.34					
45	1.23	1.43	1.67	1.98	2.25	2.61	3.04						
50	1.28	1.50	1.72	2.05	2.36	2.70	3.21						
55	1.32	1.54	1.77	2.08	2.44	2.80	3.28						
60	1.36	1.60	1.82	2.16	2.52	2.90	3.40						
65	1.40	1.64	1.90	2.22	2.60	3.00							
70	1.44	1.66	1.92	2.30	2.64	3.10							

ASD TR 61-191(II)

III-30

TABLE III A-13
 LINEAR STRETCH FORMING LIMITS
 HEEL-OUT ANGLES & CHANNELS
 HASTELLOY X
 (SOLUTION TREATED)

Contour Radius R_c	Material Thickness (t)												
	.016	.020	.025	.032	.040	.050	.063	.071	.080	.090	.100	.125	.187
	Section Height Limits (h)												
5	.80	1.00	1.25	1.34	1.37	1.45	1.52	1.57	1.60	1.62	1.65	1.75	1.87
10	.80	1.00	1.25	1.60	2.00	2.38	2.56	2.64	2.70	2.80	2.85	3.00	
15	.90	1.02	1.25	1.60	2.00	2.50	3.15						
20	.99	1.14	1.30	1.60	2.00	2.50	3.15						
25	1.07	1.24	1.42	1.66	2.00	2.50	3.15						
30	1.12	1.30	1.50	1.77	2.04	2.50	3.15						
35	1.19	1.37	1.57	1.87	2.16	2.50	3.15						
40	1.25	1.44	1.67	1.98	2.25	2.60	3.15						
45	1.30	1.50	1.72	2.05	2.35	2.71	3.15						
50	1.35	1.55	1.80	2.13	2.48	2.81	3.15						
55	1.39	1.60	1.86	2.18	2.54	2.96	3.15						
60	1.43	1.66	1.91	2.24	2.60	3.00							
65	1.47	1.70	1.97	2.32	2.70	3.12							
70	1.51	1.74	2.00	2.37	2.72	3.20							

TABLE III A-14
 LINEAR STRETCH FORMING LIMITS
 HEEL-OUT ANGLES & CHANNELS
 L-605
 (SOLUTION TREATED)

Contour Radius R	Material Thickness (t)												
	.016	.020	.025	.032	.040	.050	.063	.071	.080	.090	.100	.125	.187
	Section Height Limits (h)												
5	.80	1.00	1.16	1.26	1.33	1.40	1.47	1.51	1.54	1.57	1.60	1.67	1.79
10	.80	1.00	1.25	1.60	2.00	2.35	2.53	2.63	2.70	2.77	2.82	2.97	3.22
15	.90	1.04	1.25	1.60	2.00	2.50	3.15						
20	1.01	1.16	1.31	1.60	2.00	2.50	3.15						
25	1.06	1.24	1.41	1.66	2.00	2.50	3.15						
30	1.12	1.30	1.50	1.78	2.04	2.50	3.15						
35	1.18	1.36	1.58	1.86	2.16	2.50	3.15						
40	1.25	1.44	1.67	1.98	2.25	2.61	3.15						
45	1.30	1.50	1.70	2.05	2.34	2.71	3.15						
50	1.35	1.56	1.80	2.15	2.48	2.84	3.15						
55	1.39	1.60	1.85	2.18	2.52	2.91	3.15						
60	1.44	1.66	1.92	2.27	2.64	3.05							
65	1.47	1.70	1.97	2.32	2.70	3.12							
70	1.50	1.74	2.02	2.37	2.72	3.20							

TABLE III A-15
 LINEAR STRETCH FORMING LIMITS
 HEEL-OUT ANGLES & CHANNELS
 COLUMBIUM (10Mo-10Ti)

Contour Radius R_c	Material Thickness (t)												
	.016	.020	.025	.032	.040	.050	.063	.071	.080	.090	.100	.125	.187
	Section Height Limits (h)												
5	.43	.51	.55	.58	.62	.64	.67	.67	.70	.72	.73	.77	.80
10	.47	.54	.67	.86	1.01	1.07	1.15	1.19	1.22	1.25	1.27	1.35	1.44
15	.54	.62	.73	.86	1.08	1.35	1.54	1.57	1.62	1.66	1.71	1.82	2.00
20	.60	.70	.80	.94	1.08	1.35	1.70	1.92	2.02	2.14	2.20	2.31	2.49
25	.64	.75	.87	1.02	1.18	1.36	1.70	1.92	2.16	2.43	2.53	2.72	2.95
30	.68	.79	.90	1.08	1.24	1.40	1.70	1.92	2.16	2.43	2.70	3.02	
35	.71	.83	.95	1.14	1.31	1.50	1.76	1.92	2.16	2.43	2.70	3.37	
40	.75	.87	1.00	1.19	1.37	1.59	1.84	1.92	2.16	2.43	2.70	3.37	
45	.78	.91	1.05	1.24	1.44	1.65	1.94	2.09	2.27	2.43	2.70	3.37	
50	.80	.93	1.09	1.28	1.48	1.71	2.00	2.15	2.33	2.52	2.70	3.37	
55	.83	.96	1.11	1.29	1.52	1.78	2.07	2.26	2.41	2.59	2.78	3.37	
60	.86	1.00	1.15	1.37	1.60	1.84	2.14	2.33	2.53	2.70	2.90	3.37	
65	.89	1.04	1.20	1.41	1.63	1.90	2.20	2.39	2.57	2.79	2.97	3.47	
70	.90	1.05	1.21	1.42	1.67	1.92	2.26	2.42	2.62	2.86	3.02		

TABLE III A-16
 LINEAR STRETCH FORMING LIMITS
 HEEL-OUT ANGLES & CHANNELS
 MOLYBDENUM (.5% Ti)
 (HOT ROLLED, STRESS RELIEVED & DE-SCALED)

Contour Radius R_c	Material Thickness (t)												
	.016	.020	.025	.032	.040	.050	.063	.071	.080	.090	.100	.125	.187
	Section Height Limits (h)												
5	.43	.54	.58	.61	.66	.69	.72	.75	.75	.77	.79	.82	.86
10	.47	.54	.58	.61	.66	1.16	1.22	1.29	1.32	1.35	1.38	1.46	1.55
15	.54	.62	.72	.86	1.08	1.35	1.66	1.69	1.75	1.80	1.84	1.95	2.13
20	.60	.69	.80	.94	1.08	1.35	1.70	1.92	2.16	2.29	2.34	2.50	2.67
25	.64	.74	.86	1.02	1.17	1.35	1.70	1.92	2.16	2.43	2.70	2.89	3.14
30	.68	.78	.91	1.08	1.25	1.44	1.70	1.92	2.16	2.43	2.70	3.25	
35	.71	.84	.95	1.13	1.30	1.51	1.76	1.92	2.16	2.43	2.70	3.37	
40	.75	.87	1.00	1.18	1.36	1.59	1.84	1.99	2.16	2.43	2.70	3.37	
45	.78	.92	1.05	1.25	1.44	1.65	1.96	2.09	2.26	2.45	2.70	3.37	
50	.80	.93	1.08	1.28	1.48	1.70	2.00	2.15	2.33	2.52	2.70	3.37	
55	.83	.96	1.11	1.29	1.53	1.76	2.07	2.25	2.41	2.62	2.79	3.37	
60	.87	1.00	1.15	1.32	1.59	1.81	2.14	2.29	2.50	2.70	2.89	3.37	
65	.88	1.02	1.19	1.40	1.60	1.89	2.19	2.34	2.55	2.73	2.92	3.41	
70	.90	1.04	1.20	1.41	1.65	1.91	2.25	2.41	2.61	2.86	3.01		

TABLE III A-17
 LINEAR STRETCH FORMING LIMITS
 HEEL-CUT ANGLES & CHANNELS
 J-1570
 (SOLUTION TREATED)

Contour Radius R_c	Material Thickness (t)												
	.016	.020	.025	.032	.040	.050	.063	.071	.080	.090	.100	.125	.187
	Section Height Limits (h)												
5	.81	1.01	1.25	1.34	1.41	1.50	1.57	1.60	1.64	1.66	1.70	1.79	1.91
10	.81	1.01	1.26	1.62	2.02	2.43	2.69	2.71	2.78	2.90	3.00		
15	.91	1.04	1.25	1.62	2.02	2.52	3.18						
20	1.02	1.16	1.33	1.62	2.02	2.52	3.18						
25	1.08	1.25	1.45	1.69	2.02	2.52	3.18						
30	1.15	1.34	1.55	1.80	2.02	2.52	3.18						
35	1.20	1.40	1.62	1.92	2.20	2.52	3.18						
40	1.28	1.45	1.70	2.00	2.32	2.65	3.18						
45	1.32	1.54	1.79	2.08	2.44	2.79	3.21						
50	1.38	1.60	1.84	2.14	2.50	2.90	3.40						
55	1.41	1.64	1.87	2.24	2.60	3.01							
60	1.47	1.70	1.95	2.30	2.69	3.10							
65	1.52	1.73	2.00	2.37	2.72	3.17							
70	1.54	1.79	2.05	2.40	2.80	3.25							

TABLES III A-18 THROUGH III A-34 LINEAR STRETCH FORMABILITY LIMITS
HEEL-IN ANGLES AND CHANNELS

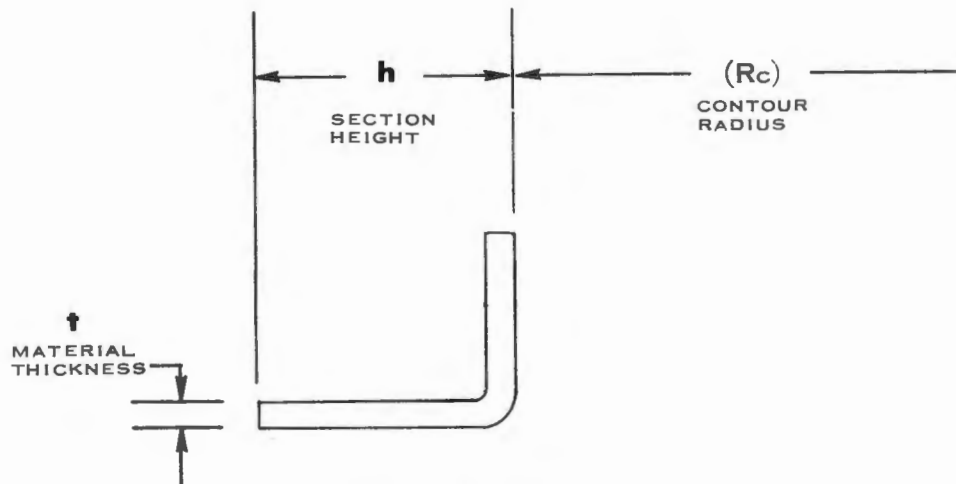

HEEL-IN ANGLE
FIGURE IIIA-18

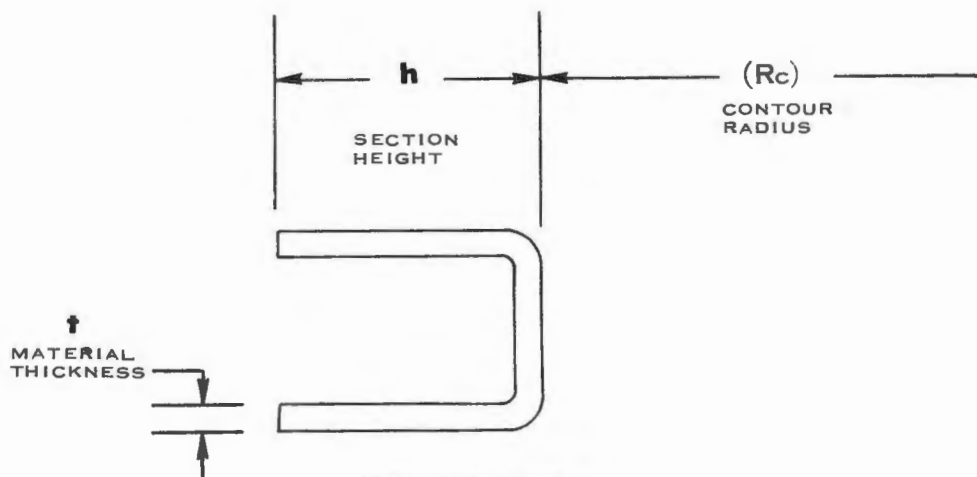

FIGURE IIIA-19
HEEL-IN CHANNEL

TABLE III A-18
 LINEAR STRETCH FORMING LIMITS
 HEEL-IN ANGLES & CHANNELS
 HM21XA-T8 (MAGNESIUM THORIUM)
 (400-600 °F)

Contour Radius R_c	Material Thickness (t)												
	.016	.020	.025	.032	.040	.050	.063	.071	.080	.090	.100	.125	.187
	Section Height Limits (h)												
5	.90	1.05	1.22	1.42	1.68	1.97	2.25	2.43	2.59	2.70	2.80	3.00	
10	1.14	1.33	1.54	1.80	2.10	2.44	2.85	3.07					
15	1.30	1.50	1.75	2.07	2.37	2.77	3.27						
20	1.45	1.65	1.94	2.28	2.64	3.08							
25	1.55	1.80	2.10	2.47	2.85	3.30							
30	1.63	1.89	2.22	2.62	3.00								
35	1.73	2.03	2.34	2.76	3.18								
40	1.80	2.08	2.46	2.92	3.32								
45	1.89	2.18	2.52	2.97	3.46								
50	1.95	2.25	2.60	3.10									
55	2.00	2.31	2.67	3.19									
60	2.08	2.40	2.80	3.30									
65	2.12	2.44	2.83	3.38									
70	2.17	2.49	2.90	3.43									

ASD TR 61-191(II)

III-38

TABLE III A-19
 LINEAR STRETCH FORMING LIMITS
 HEEL-IN ANGLES & CHANNELS
 2024-O ALUMINUM

Contour Radius R_c	Material Thickness (t)												
	.016	.020	.025	.032	.040	.050	.063	.071	.080	.090	.100	.125	.187
	Section Height Limits (h)												
5	.88	.96	1.06	1.15	1.26	1.35	1.44	1.50	1.55	1.60	1.66	1.76	1.94
10	1.28	1.43	1.58	1.77	1.95	2.13	2.32	2.42	2.51	2.63	2.71	2.90	3.27
15	1.45	1.69	1.95	2.20	2.44	2.67	2.95	3.09					
20	1.60	1.86	2.14	2.56	2.86	3.18							
25	1.70	1.97	2.30	2.72	3.15								
30	1.83	2.10	2.46	2.88	3.36								
35	1.92	2.24	2.59	3.04									
40	2.02	2.32	2.70	3.16									
45	2.09	2.43	2.79	3.24									
50	2.17	2.47	2.90	3.37									
55	2.23	2.58	3.02										
60	2.34	2.67	3.09										
65	2.37	2.73	3.15										
70	2.41	2.80	3.29										

ASD TR 61-191(II)

III-39

TABLE III A-20
 LINEAR STRETCH FORMING LIMITS
 HEEL-IN ANGLES & CHANNELS
 17-7 PH
 (CONDITION A, MILL ANNEALED)

Contour Radius R_c	Material Thickness (t)												
	.016	.020	.025	.032	.040	.050	.063	.071	.080	.090	.100	.125	.187
	Section Height Limits (h)												
5	.87	1.02	1.18	1.38	1.60	1.80	1.97	2.05	2.14	2.22	2.30	2.46	2.75
10	1.11	1.28	1.49	1.76	2.05	2.38	2.77	2.99	3.12				
15	1.27	1.47	1.70	2.02	2.31	2.74	3.18						
20	1.38	1.60	1.87	2.20	2.56	2.96	3.50						
25	1.50	1.72	2.00	2.40	2.75	3.17							
30	1.59	1.86	2.16	2.52	2.92	3.36							
35	1.68	1.99	2.24	2.66	3.08								
40	1.75	2.04	2.36	2.72	3.20								
45	1.84	2.11	2.43	2.92	3.37								
50	1.90	2.18	2.55	2.97	3.45								
55	1.98	2.28	2.64	3.08									
60	2.01	2.34	2.70	3.18									
65	2.06	2.40	2.77	3.31									
70	2.10	2.44	2.80	3.36									

ASD TR 61-191(II)

III-40

TABLE III A-21
 LINEAR STRETCH FORMING LIMITS
 HEEL-IN ANGLES & CHANNELS
 PH 15-7 Mo
 (CONDITION A)

Contour Radius R_c	Material Thickness (t)												
	.016	.020	.025	.032	.040	.050	.063	.071	.080	.090	.100	.125	.187
	Section Height Limits (h)												
5	.87	1.02	1.17	1.37	1.62	1.76	1.92	2.00	2.09	2.15	2.22	2.39	2.65
10	1.10	1.28	1.46	1.73	2.02	2.35	2.75	2.95	3.12				
15	1.24	1.45	1.69	1.99	2.31	2.67	3.12						
20	1.38	1.60	1.84	2.18	2.52	2.94	3.44						
25	1.47	1.70	2.00	2.36	2.72	3.15							
30	1.56	1.86	2.10	2.49	2.88	3.36							
35	1.64	1.92	2.22	2.62	3.04								
40	1.72	1.98	2.30	2.72	3.20								
45	1.80	2.07	2.41	2.83	3.28								
50	1.85	2.15	2.47	2.90	3.40								
55	1.92	2.25	2.58	3.02									
60	1.98	2.34	2.64	3.16									
65	2.01	2.37	2.73	3.25									
70	2.06	2.41	2.80	3.29									

ASD TR 61-191(II)

III-41

TABLE III A-22
 LINEAR STRETCH FORMING LIMITS
 HEEL-IN ANGLES & CHANNELS
 AM-350
 (ANNEALED)

Contour Radius R_c	Material Thickness (t)												
	.016	.020	.025	.032	.040	.050	.063	.071	.080	.090	.100	.125	.187
	Section Height Limits (h)												
5	.80	.92	1.08	1.27	1.47	1.70	2.00	2.08	2.18	2.23	2.31	2.49	2.70
10	1.02	1.18	1.37	1.62	1.88	2.18	2.55	2.75	2.95	3.12			
15	1.12	1.33	1.57	1.89	2.14	2.50	2.91	3.12					
20	1.26	1.48	1.70	2.04	2.36	2.74	3.20						
25	1.37	1.57	1.85	2.19	2.50	2.92	3.57						
30	1.44	1.68	1.95	2.31	2.64	3.09							
35	1.54	1.78	2.06	2.43	2.80	3.32							
40	1.60	1.84	2.14	2.54	2.92	3.40							
45	1.69	1.93	2.25	2.65	3.06								
50	1.75	2.02	2.30	2.72	3.20								
55	1.79	2.06	2.36	2.83	3.30								
60	1.83	2.13	2.46	2.94	3.36								
65	1.88	2.18	2.53	3.02									
70	1.92	2.24	2.59	3.04									

TABLE III A-24
 LINEAR STRETCH FORMING LIMITS
 HEEL-IN ANGLES & CHANNELS
 USS-12-MoV
 (ANNEALED)

Contour Radius R_c	Material Thickness (t)												
	.016	.020	.025	.032	.040	.050	.063	.071	.080	.090	.100	.125	.187
	Section Height Limits (h)												
5	.80	.93	1.10	1.19	1.29	1.39	1.50	1.56	1.60	1.67	1.72	1.81	2.00
10	1.10	1.18	1.37	1.60	1.85	2.20	2.37	2.48	2.59	2.70	2.79	3.00	
15	1.17	1.32	1.56	1.84	2.10	2.47	2.89	3.09					
20	1.26	1.46	1.70	2.02	2.36	2.74	3.16						
25	1.37	1.57	1.85	2.19	2.50	2.95	3.55						
30	1.45	1.68	1.95	2.32	2.64	3.09							
35	1.52	1.78	2.05	2.43	2.80	3.32							
40	1.60	1.84	2.16	2.54	2.94	3.40							
45	1.68	1.93	2.20	2.65	3.06								
50	1.75	2.00	2.30	2.70	3.15								
55	1.79	2.06	2.36	2.80	3.30								
60	1.86	2.13	2.46	2.94	3.42								
65	1.88	2.18	2.52	2.99	3.51								
70	1.92	2.22	2.59	3.03									

TABLE III A-25
 LINEAR STRETCH FORMING LIMITS
 HEEL-IN ANGLES & CHANNELS
 TITANIUM (6Al-4V)
 (MILL ANNEALED)

Contour Radius R_c	Material Thickness (t)												
	.016	.020	.025	.032	.040	.050	.063	.071	.080	.090	.100	.125	.187
	Section Height Limits (h)												
5	.49	.58	.67	.79	.92	1.06	1.18	1.22	1.27	1.32	1.36	1.43	1.59
10	.63	.72	.84	.99	1.16	1.35	1.56	1.68	1.82	2.00	2.12	2.45	2.64
15	.72	.82	.96	1.14	1.30	1.54	1.80	1.93	2.08	2.25	2.43	2.80	3.52
20	.78	.91	1.06	1.25	1.44	1.66	1.94	2.12	2.32	2.46	2.66	3.10	
25	.85	.97	1.15	1.35	1.55	1.80	2.17	2.29	2.50	2.70	2.87	3.37	
30	.88	1.03	1.20	1.42	1.65	1.90	2.25	2.40	2.62	2.85	3.09		
35	.94	1.12	1.28	1.50	1.75	2.03	2.34	2.59	2.76	3.01			
40	.98	1.14	1.32	1.56	1.84	2.12	2.42	2.70	2.88	3.08			
45	1.03	1.19	1.39	1.62	1.89	2.20	2.56	2.79	3.01				
50	1.07	1.25	1.44	1.67	1.95	2.30	2.70	2.87	3.10				
55	1.10	1.29	1.48	1.76	2.03	2.34	2.75	2.97	3.24				
60	1.14	1.32	1.54	1.80	2.08	2.43	2.85	3.06					
65	1.16	1.38	1.56	1.85	2.14	2.50	2.92	3.15					
70	1.19	1.40	1.61	1.89	2.20	2.55	2.97	3.20					

TABLE III A-26
 LINEAR STRETCH FORMING LIMITS
 HEEL-IN ANGLES & CHANNELS
 TITANIUM (13V-11Cr-3Al)
 (SOLUTION TREATED)

Contour Radius R _c	Material Thickness (t)												
	.016	.020	.025	.032	.040	.050	.063	.071	.080	.090	.100	.125	.187
	Section Height Limits (h)												
5	.49	.57	.66	.77	.91	1.05	1.22	1.29	1.33	1.37	1.42	1.50	1.64
10	.62	.72	.83	.98	1.14	1.33	1.54	1.67	1.81	1.98	2.10	2.40	2.77
15	.71	.82	.94	1.12	1.29	1.51	1.77	1.90	2.07	2.25	2.40	2.77	3.67
20	.78	.89	1.04	1.24	1.44	1.65	1.96	2.10	2.28	2.44	2.64	3.05	
25	.85	.97	1.13	1.33	1.55	1.80	2.17	2.27	2.47	2.67	2.87	3.30	
30	.88	1.02	1.18	1.41	1.63	1.89	2.22	2.37	2.59	2.80	3.06		
35	.93	1.08	1.24	1.49	1.71	1.99	2.34	2.53	2.73	2.96	3.20		
40	.98	1.14	1.32	1.56	1.80	2.10	2.46	2.66	2.86	3.08			
45	1.02	1.19	1.37	1.60	1.87	2.17	2.56	2.79	3.01				
50	1.06	1.22	1.40	1.65	1.95	2.25	2.65	2.85	3.10				
55	1.10	1.24	1.45	1.70	1.98	2.28	2.69	2.91	3.13				
60	1.11	1.29	1.50	1.77	2.04	2.40	2.76	3.00					
65	1.14	1.33	1.54	1.84	2.11	2.47	2.91	3.12					
70	1.17	1.35	1.57	1.85	2.16	2.49	2.94	3.15					

ASD TR 61-191(II)

III-46

TABLE III A-2.7
 LINEAR STRETCH FORMING LIMITS
 HEEL-IN ANGLES & CHANNELS
 VASCOJET 1000 (H-11)
 (ANNEALED)

Contour Radius R_c	Material Thickness (t)												
	.016	.020	.025	.032	.040	.050	.063	.071	.080	.090	.100	.125	.187
	Section Height Limits (h)												
5	.76	.88	.96	1.04	1.12	1.20	1.30	1.34	1.38	1.43	1.47	1.53	1.70
10	.96	1.12	1.29	1.52	1.75	1.90	2.07	2.15	2.25	2.33	2.41	2.58	2.88
15	1.09	1.26	1.47	1.77	1.86	2.34	2.67	2.79	2.92	3.04			
20	1.20	1.38	1.60	1.90	2.20	2.56	3.00						
25	1.32	1.50	1.75	2.07	2.37	2.80	3.37						
30	1.38	1.59	1.83	2.17	2.52	2.92	3.51						
35	1.44	1.70	1.94	2.31	2.69	3.11							
40	1.52	1.76	2.04	2.40	2.80	3.36							
45	1.58	1.84	2.11	2.47	2.88	3.42							
50	1.64	1.89	2.18	2.55	3.00								
55	1.68	1.95	2.25	2.69	3.13								
60	1.74	2.02	2.34	2.76	3.18								
65	1.79	2.07	2.37	2.86	3.30								
70	1.82	2.12	2.46	2.94	3.36								

ASD TR 61-191(II)

III-47

TABLE III A-29
 LINEAR STRETCH FORMING LIMITS
 HEEL-IN ANGLES & CHANNELS
 INCONEL X
 (C.R. ANNEALED)

Contour Radius R _c	Material Thickness (t)												
	.016	.020	.025	.032	.040	.050	.063	.071	.080	.090	.100	.125	.187
	Section Height Limits (h)												
5	.86	1.01	1.17	1.36	1.59	1.84	2.15	2.30	2.50	2.70	2.95	3.04	
10	1.10	1.26	1.45	1.73	2.00	2.33	2.71	2.92	3.09				
15	1.25	1.44	1.68	1.99	2.25	2.62	3.00						
20	1.36	1.56	1.84	2.16	2.54	2.90	3.40						
25	1.47	1.70	1.95	2.35	2.70	3.15							
30	1.56	1.80	2.07	2.49	2.85	3.30							
35	1.64	1.94	2.20	2.62	3.01								
40	1.71	1.98	2.32	2.72	3.20								
45	1.80	2.07	2.38	2.81	3.26								
50	1.85	2.15	2.45	2.90	3.40								
55	1.92	2.20	2.56	3.02									
60	1.98	2.28	2.64	3.12									
65	2.01	2.34	2.70	3.22									
70	2.03	2.38	2.76	3.25									

ASD TR 61-191(II)

III 49

TABLE III A-30
 LINEAR STRETCH FORMING LIMITS
 HEEL-IN ANGLES & CHANNELS
 HASTELLOY X
 (SOLUTION TREATED)

Contour Radius R_c	Material Thickness (t)												
	.016	.020	.025	.032	.040	.050	.063	.071	.080	.090	.100	.125	.187
	Section Height Limits (h)												
5	.77	.91	1.05	1.23	1.44	1.83	1.97	2.10	2.29	2.40	2.50	2.66	2.97
10	.98	1.16	1.33	1.56	1.82	2.11	2.46	2.65	2.88	3.08			
15	1.14	1.30	1.53	1.81	2.05	2.43	2.67	3.04					
20	1.25	1.44	1.66	1.97	2.30	2.67	3.10						
25	1.35	1.56	1.81	2.15	2.45	2.87	3.45						
30	1.41	1.65	1.89	2.25	2.61	3.00							
35	1.49	1.75	1.99	2.36	2.73	3.22							
40	1.56	1.80	2.10	2.48	2.88	3.30							
45	1.65	1.89	2.18	2.58	3.01								
50	1.70	1.95	2.25	2.65	3.10								
55	1.73	2.01	2.33	2.75	3.19								
60	1.77	2.08	2.40	2.83	3.26								
65	1.85	2.14	2.47	2.92	3.44								
70	1.88	2.17	2.52	2.97	3.50								

ASD TR 61-191(II)

III-50

TABLE III A-31
 LINEAR STRETCH FORMING LIMITS
 HEEL-IN ANGLES & CHANNELS
 L-605
 (SOLUTION TREATED)

Contour Radius R_c	Material Thickness (t)												
	.016	.020	.025	.032	.040	.050	.063	.071	.080	.090	.100	.125	.187
	Section Height Limits (h)												
5	.81	.95	1.09	1.28	1.50	1.75	2.05	2.18	2.27	2.36	2.43	2.55	2.88
10	1.00	1.16	1.33	1.58	1.83	2.15	2.50	2.70	2.90	3.10			
15	1.12	1.30	1.50	1.78	2.05	2.38	2.79	3.00					
20	1.25	1.44	1.66	1.99	2.32	2.65	3.10						
25	1.35	1.52	1.82	2.16	2.47	2.90	3.47						
30	1.41	1.65	1.90	2.28	2.61	3.03							
35	1.50	1.75	2.03	2.38	2.76	3.22							
40	1.56	1.80	2.12	2.48	2.88	3.32							
45	1.64	1.91	2.20	2.56	3.01								
50	1.70	1.95	2.25	2.67	3.10								
55	1.76	2.03	2.36	2.78	3.19								
60	1.80	2.10	2.43	2.91	3.30								
65	1.85	2.14	2.50	2.99	3.41								
70	1.90	2.17	2.57	3.04									

TABLE III A-32
 LINEAR STRETCH FORMING LIMITS
 HEEL-IN ANGLES & CHANNELS
 COLUMBIUM (10Mo-10Ti)

Contour Radius R_c	Material Thickness (t)												
	.016	.020	.025	.032	.040	.050	.063	.071	.080	.090	.100	.125	.187
	Section Height Limits (h)												
5	.47	.55	.64	.69	.74	.79	.84	.89	.90	.92	.95	1.00	1.08
10	.60	.69	.80	.94	1.08	1.28	1.37	1.42	1.48	1.52	1.58	1.67	1.86
15	.67	.79	.91	1.08	1.23	1.45	1.71	1.86	1.95	2.02	2.10	2.25	2.50
20	.75	.86	1.00	1.19	1.36	1.62	1.88	2.02	2.18	2.36	2.56	2.74	3.10
25	.82	.92	1.09	1.29	1.47	1.72	2.10	2.20	2.37	2.55	2.75	3.20	
30	.88	.99	1.15	1.35	1.59	1.83	2.16	2.31	2.53	2.76	2.94	3.42	
35	.91	1.05	1.22	1.43	1.64	1.92	2.24	2.45	2.62	2.83	3.08		
40	.94	1.10	1.28	1.50	1.74	2.00	2.36	2.56	2.76	2.96	3.20		
45	.99	1.15	1.33	1.57	1.82	2.11	2.47	2.70	2.90	3.15			
50	1.02	1.17	1.37	1.60	1.85	2.17	2.55	2.75	3.00				
55	1.04	1.21	1.40	1.65	1.92	2.21	2.61	2.86	3.08				
60	1.08	1.26	1.47	1.71	2.01	2.34	2.70	2.94	3.18				
65	1.10	1.29	1.49	1.79	2.08	2.40	2.79	3.05					
70	1.12	1.31	1.54	1.82	2.12	2.45	2.87	3.11					

ASD TR 61-191(II)

III-52

TABLE III A-33
 LINEAR STRETCH FORMING LIMITS
 HEEL-IN ANGLES & CHANNELS
 MOLYBDENUM (.5% Ti)
 (HOT ROLLED, STRESS RELIEVED & DE-SCALED)

Contour Radius R_c	Material Thickness (t)												
	.016	.020	.025	.032	.040	.050	.063	.071	.080	.090	.100	.125	.187
	Section Height Limits (h)												
5	.47	.55	.64	.74	.82	.87	.92	.95	.99	1.01	1.04	1.09	1.17
10	.60	.69	.80	.94	1.08	1.28	1.48	1.58	1.64	1.70	1.75	1.85	2.04
15	.67	.79	.91	1.08	1.23	1.45	1.71	1.86	1.99	2.14	2.32	2.47	2.77
20	.75	.86	1.00	1.19	1.36	1.62	1.88	2.02	2.18	2.36	2.56	2.94	3.40
25	.82	.92	1.09	1.29	1.47	1.72	2.10	2.20	2.37	2.55	2.75	3.20	
30	.88	.99	1.15	1.35	1.59	1.83	2.16	2.31	2.53	2.76	2.94	3.42	
35	.91	1.05	1.22	1.43	1.64	1.92	2.24	2.45	2.62	2.83	3.08		
40	.94	1.10	1.28	1.50	1.74	2.00	2.36	2.56	2.76	2.96			
45	.99	1.15	1.33	1.57	1.82	2.11	2.47	2.70	2.90	3.15			
50	1.02	1.17	1.37	1.60	1.85	2.17	2.55	2.75	3.00				
55	1.04	1.21	1.40	1.65	1.92	2.21	2.61	2.86	3.08				
60	1.08	1.26	1.47	1.71	2.01	2.34	2.70	2.94	3.18				
65	1.10	1.29	1.49	1.79	2.08	2.40	2.79	3.05					
70	1.12	1.31	1.54	1.82	2.12	2.45	2.87	3.11					

ASD TR 61-191(II)

III-53

TABLES III A-35 THROUGH III A-51 LINEAR STRETCH FORMABILITY LIMITS
HEEL-IN HAT SECTIONS

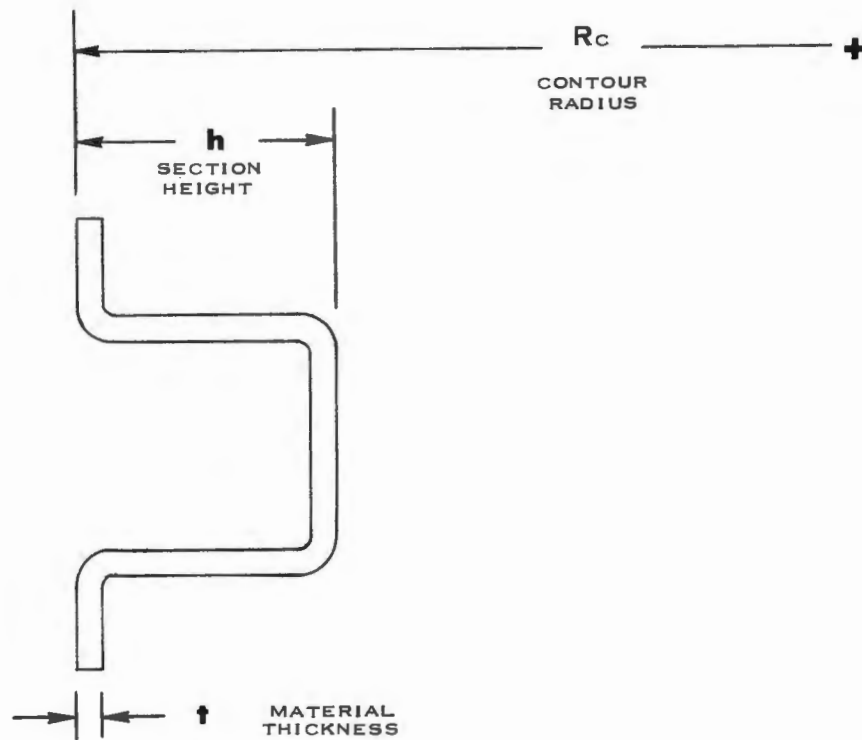

FIGURE IIIA-20
HEEL-IN HAT SECTIONS

TABLE III A-36
 LINEAR STRETCH FORMING LIMITS
 HEEL-IN HAT SECTIONS
 2024-O ALUMINUM

Contour Radius R_c	Material Thickness (t)												
	.016	.020	.025	.032	.040	.050	.063	.071	.080	.090	.100	.125	.187
	Section Height Limits (h)												
5	.66	.69	.75	.80	.85	.90	.94	.97	.98	.99	1.01	1.06	1.07
10	.98	1.10	1.17	1.28	1.38	1.47	1.57	1.63	1.68	1.75	1.80	1.87	2.02
15	1.14	1.30	1.50	1.66	1.80	1.95	2.14	2.17	2.24	2.34	2.38	2.50	2.75
20	1.24	1.44	1.65	1.93	2.24	2.35	2.52	2.66	2.72	2.88	2.95	3.12	
25	1.33	1.54	1.80	2.09	2.40	2.75	2.96	3.12					
30	1.42	1.64	1.90	2.24	2.60	2.95	3.21						
35	1.47	1.72	2.00	2.37	2.72	3.15							
40	1.58	1.82	2.12	2.48	2.84	3.30							
45	1.63	1.90	2.20	2.56	3.00								
50	1.70	1.96	2.27	2.69	3.08								
55	1.76	2.04	2.35	2.75	3.20								
60	1.81	2.10	2.42	2.85	3.28								
65	1.86	2.16	2.50	2.94	3.40								
70	1.92	2.20	2.55	3.01									

ASD TR 61-191(II)

III-57

TABLE III A-37
 LINEAR STRETCH FORMING LIMITS
 HEEL-IN HAT SECTIONS
 17-7 PH
 (CONDITION A, MILL ANNEALED)

Contour Radius R_c	Material Thickness (t)												
	.016	.020	.025	.032	.040	.050	.063	.071	.080	.090	.100	.125	.187
	Section Height Limits (h)												
5	.68	.78	.90	1.02	1.10	1.15	1.22	1.24	1.28	1.29	1.32	1.37	1.46
10	.86	1.00	1.15	1.34	1.52	1.77	2.03	2.13	2.20	2.25	2.30	2.37	2.62
15	.99	1.15	1.34	1.55	1.80	2.07	2.39	2.56	2.80	3.01			
20	1.10	1.27	1.45	1.73	1.96	2.30	2.65	2.87	3.08				
25	1.20	1.36	1.60	1.86	2.16	2.50	2.90	3.12					
30	1.26	1.46	1.69	1.98	2.30	2.65	3.09						
35	1.31	1.54	1.77	2.08	2.40	2.80	3.27						
40	1.41	1.62	1.90	2.24	2.58	2.95	3.46						
45	1.46	1.68	1.95	2.30	2.66	3.05							
50	1.52	1.76	2.02	2.40	2.76	3.20							
55	1.55	1.80	2.05	2.45	2.84	3.30							
60	1.60	1.86	2.15	2.53	2.96	3.40							
65	1.63	1.90	2.20	2.58	3.00								
70	1.69	1.93	2.25	2.63	3.08								

ASD TR 61-191(II)

III-58

TABLE III A-39
 LINEAR STRETCH FORMING LIMITS
 HEEL-IN HAT SECTIONS
 AM-350
 (ANNEALED)

Contour Radius R_c	Material Thickness (t)												
	.016	.020	.025	.032	.040	.050	.063	.071	.080	.090	.100	.125	.187
	Section Height Limits (h)												
5	.62	.70	.82	.94	1.08	1.15	1.20	1.24	1.26	1.28	1.30	1.37	1.48
10	.78	.90	1.05	1.24	1.40	1.62	1.88	2.03	2.16	2.20	2.30	2.41	2.62
15	.90	1.04	1.21	1.34	1.64	1.87	2.17	2.34	2.52	2.72	2.90	3.20	
20	1.00	1.16	1.32	1.57	1.80	2.10	2.41	2.63	2.80	3.06			
25	1.08	1.25	1.45	1.70	1.96	2.25	2.61	2.84	3.08				
30	1.15	1.32	1.55	1.81	2.10	2.42	2.80	3.05					
35	1.19	1.38	1.62	1.90	2.18	2.55	2.96	3.19					
40	1.26	1.46	1.70	2.00	2.32	2.67	3.09						
45	1.31	1.54	1.76	2.08	2.40	2.75	3.21						
50	1.36	1.59	1.82	2.18	2.50	2.85	3.37						
55	1.40	1.64	1.90	2.22	2.60	3.00							
60	1.44	1.70	1.95	2.30	2.68	3.10							
65	1.47	1.72	2.00	2.37	2.72	3.20							
70	1.52	1.76	2.05	2.40	2.76	3.25							

ASD TR 61-191(II)

III-60

TABLE III A-40
 LINEAR STRETCH FORMING LIMITS
 HEEL-IN HAT SECTIONS
 A-286
 (SOLUTION TREATED)

Contour Radius R_c	Material Thickness (t)												
	.016	.020	.025	.032	.040	.050	.063	.071	.080	.090	.100	.125	.187
	Section Height Limits (h)												
5	.72	.82	.95	1.10	1.18	1.26	1.31	1.35	1.38	1.40	1.44	1.50	1.59
10	.91	1.06	1.22	1.44	1.64	1.87	2.19	2.21	2.34	2.43	2.52	2.59	2.86
15	1.06	1.22	1.42	1.65	1.88	2.20	2.52	2.70	2.92	3.15			
20	1.17	1.36	1.55	1.87	2.06	2.47	2.80	3.05					
25	1.26	1.44	1.70	1.98	2.28	2.65	3.09						
30	1.34	1.56	1.80	2.11	2.44	2.85	3.24						
35	1.41	1.64	1.87	2.24	2.56	2.96	3.44						
40	1.48	1.72	1.97	2.30	2.68	3.10							
45	1.54	1.76	2.07	2.42	2.80	3.25							
50	1.60	1.85	2.15	2.56	2.92	3.35							
55	1.63	1.90	2.20	2.60	3.00								
60	1.71	1.98	2.27	2.69	3.12								
65	1.76	2.02	2.37	2.75	3.20								
70	1.79	2.06	2.40	2.85	3.28								

ASD TR 61-191(II)

III-61

TABLE III A-41
 LINEAR STRETCH FORMING LIMITS
 HEEL-IN HAT SECTIONS
 USS-12-MoV
 (ANNEALED)

Contour Radius R_c	Material Thickness (t)												
	.016	.020	.025	.032	.040	.050	.063	.071	.080	.090	.100	.125	.187
	Section Height Limits (h)												
5	.62	.70	.75	.80	.86	.90	.94	.96	.98	.99	1.01	1.06	1.12
10	.78	.90	1.05	1.22	1.36	1.47	1.57	1.63	1.68	1.75	1.79	1.87	2.02
15	.91	1.04	1.20	1.41	1.64	1.90	2.12	2.20	2.24	2.34	2.40	2.55	2.80
20	1.01	1.16	1.34	1.57	1.80	2.10	2.46	2.63	2.72	2.90	3.00		
25	1.09	1.24	1.45	1.70	1.96	2.25	2.65	2.84	3.04				
30	1.14	1.34	1.55	1.82	2.08	2.45	2.80	3.05					
35	1.20	1.40	1.62	1.92	2.20	2.55	2.96	3.19					
40	1.26	1.46	1.70	2.00	2.28	2.65	3.09						
45	1.31	1.52	1.75	2.08	2.40	2.75	3.21						
50	1.36	1.60	1.85	2.18	2.52	2.90	3.35						
55	1.41	1.64	1.87	2.21	2.60	3.00							
60	1.44	1.70	1.95	2.30	2.68	3.10							
65	1.49	1.72	2.00	2.37	2.74	3.20							
70	1.52	1.76	2.05	2.40	2.80	3.25							

TABLE III A-42
 LINEAR STRETCH FORMING LIMITS
 HEEL-IN HAT SECTIONS
 TITANIUM (6Al-4V)
 (MILL ANNEALED)

Contour Radius R_c	Material Thickness (t)												
	.016	.020	.025	.032	.040	.050	.063	.071	.080	.090	.100	.125	.187
	Section Height Limits (h)												
5	.39	.45	.51	.60	.68	.71	.74	.75	.77	.78	.80	.83	.86
10	.49	.56	.66	.77	.89	1.02	1.18	1.29	1.34	1.38	1.42	1.47	1.55
15	.56	.65	.75	.89	1.02	1.18	1.39	1.48	1.60	1.73	1.84	2.01	2.21
20	.62	.72	.83	.98	1.13	1.21	1.46	1.57	1.71	1.84	2.05	2.37	2.71
25	.67	.78	.90	1.06	1.22	1.41	1.66	1.79	1.94	2.10	2.23	2.65	3.29
30	.71	.83	.96	1.14	1.32	1.52	1.75	1.92	2.08	2.21	2.39	2.76	3.55
35	.75	.88	1.01	1.20	1.38	1.60	1.86	2.00	2.17	2.36	2.51	2.91	3.74
40	.78	.91	1.05	1.24	1.44	1.67	1.93	2.08	2.26	2.45	2.63	3.01	
45	.82	.94	1.10	1.30	1.52	1.72	2.02	2.20	2.36	2.56	2.74	3.19	
50	.85	.98	1.12	1.34	1.56	1.80	2.08	2.27	2.46	2.65	2.94	3.25	
55	.88	1.01	1.17	1.38	1.60	1.87	2.17	2.34	2.56	2.74	2.98	3.37	
60	.90	1.06	1.22	1.42	1.68	1.93	2.27	2.45	2.64	2.88	3.08		
65	.93	1.08	1.25	1.47	1.70	2.00	2.31	2.48	2.68	2.92	3.12		
70	.94	1.09	1.27	1.49	1.72	2.02	2.35	2.56	2.72	2.97	3.18		

ASD TR 61-191(II)

III-63

TABLE III A-4 3
 LINEAR STRETCH FORMING LIMITS
 HEEL-IN HAT SECTIONS
 TITANIUM (13V-11Cr-3Al)
 (SOLUTION TREATED)

Contour Radius R_c	Material Thickness (t)												
	.016	.020	.025	.032	.040	.050	.063	.071	.080	.090	.100	.125	.187
	Section Height Limits (h)												
5	.38	.45	.51	.60	.70	.79	.82	.84	.85	.86	.89	.92	.95
10	.50	.57	.66	.77	.89	1.02	1.18	1.28	1.38	1.48	1.55	1.62	1.80
15	.57	.65	.76	.88	1.02	1.17	1.39	1.48	1.59	1.71	1.83	2.12	2.43
20	.62	.72	.82	.98	1.12	1.32	1.51	1.63	1.76	1.92	2.05	2.35	2.99
25	.67	.78	.90	1.05	1.22	1.40	1.64	1.77	1.92	2.07	2.20	2.54	3.25
30	.71	.83	.95	1.12	1.30	1.50	1.74	1.90	2.06	2.20	2.36	2.72	3.55
35	.74	.87	1.00	1.23	1.37	1.58	1.84	1.99	2.14	2.32	2.50	2.87	3.74
40	.78	.91	1.05	1.25	1.44	1.65	1.93	2.06	2.24	2.43	2.63	3.00	
45	.82	.97	1.10	1.28	1.50	1.71	2.02	2.16	2.35	2.54	2.73	3.16	
50	.84	.98	1.14	1.34	1.56	1.80	2.08	2.27	2.44	2.64	2.80	3.30	
55	.87	1.00	1.17	1.38	1.60	1.86	2.15	2.31	2.48	2.70	2.92	3.37	
60	.90	1.05	1.20	1.41	1.66	1.91	2.24	2.42	2.61	2.83	3.00		
65	.93	1.07	1.25	1.46	1.68	1.95	2.28	2.46	2.68	2.89	3.08		
70	.94	1.10	1.27	1.50	1.72	2.01	2.36	2.56	2.72	2.97	3.17		

ASD TR 61-191(II)

III-64

TABLE III A-44
 LINEAR STRETCH FORMING LIMITS
 HEEL-IN HAT SECTIONS
 VASCOJET 1000 (H-11)
 (ANNEALED)

Contour Radius R _c	Material Thickness (t)												
	.016	.020	.025	.032	.040	.050	.063	.071	.080	.090	.100	.125	.187
	Section Height Limits (h)												
5	.59	.62	.67	.72	.76	.80	.84	.87	.88	.90	.91	.94	.99
10	.74	.86	1.00	1.17	1.24	1.32	1.42	1.48	1.52	1.55	1.58	1.65	1.78
15	.86	.98	1.15	1.34	1.54	1.75	1.89	1.95	2.02	2.07	2.13	2.25	2.47
20	.94	1.10	1.26	1.47	1.70	1.97	2.30	2.41	2.44	2.57	2.65	2.81	2.99
25	1.02	1.18	1.37	1.60	1.84	2.15	2.46	2.70	2.88	3.06			
30	1.09	1.26	1.45	1.73	1.96	2.30	2.65	2.88	3.12				
35	1.14	1.32	1.52	1.79	2.08	2.40	2.77	2.95	3.28				
40	1.20	1.38	1.62	1.89	2.20	2.55	2.96	3.16					
45	1.25	1.44	1.67	1.98	2.28	2.65	3.02						
50	1.30	1.50	1.74	2.05	2.36	2.75	3.21						
55	1.33	1.53	1.77	2.10	2.40	2.80	3.28						
60	1.36	1.60	1.85	2.18	2.52	2.90	3.40						
65	1.42	1.62	1.90	2.24	2.60	3.00							
70	1.45	1.67	1.95	2.29	2.64	3.03							

TABLE III A-45
 LINEAR STRETCH FORMING LIMITS
 HEEL-IN HAT SECTIONS
 RENE '41
 (SOLUTION TREATED)

Contour Radius R_c	Material Thickness (t)												
	.016	.020	.025	.032	.040	.050	.063	.071	.080	.090	.100	.125	.187
	Section Height Limits (h)												
5	.59	.67	.77	.91	1.05	1.19	1.36	1.39	1.45	1.47	1.50	1.57	1.68
10	.74	.86	1.00	1.17	1.34	1.52	1.79	1.93	2.08	2.23	2.37	2.69	2.99
15	.86	.98	1.15	1.34	1.56	1.79	1.95	2.23	2.40	2.56	2.76	3.19	
20	.96	1.10	1.27	1.49	1.72	2.00	2.28	2.48	2.66	2.88	3.10		
25	1.02	1.18	1.37	1.60	1.84	2.15	2.46	2.70	2.88	3.15			
30	1.09	1.25	1.47	1.73	1.98	2.30	2.65	2.87	3.12				
35	1.14	1.32	1.52	1.79	2.08	2.40	2.77	3.02					
40	1.20	1.40	1.60	1.89	2.18	2.51	2.93	3.14					
45	1.25	1.44	1.67	1.98	2.28	2.65	3.04						
50	1.28	1.50	1.72	2.08	2.36	2.75	3.21						
55	1.33	1.54	1.77	2.11	2.48	2.85	3.32						
60	1.36	1.59	1.85	2.18	2.52	2.90	3.40						
65	1.41	1.63	1.90	2.24	2.60	3.00							
70	1.44	1.68	1.95	2.30	2.64	3.15							

TABLE III A-46
 LINEAR STRETCH FORMING LIMITS
 HEEL-IN HAT SECTIONS
 INCONEL X
 (C.R. ANNEALED)

Contour Radius R_c	Material Thickness (t)												
	.016	.020	.025	.032	.040	.050	.063	.071	.080	.090	.100	.125	.187
	Section Height Limits (h)												
5	.66	.75	.87	1.02	1.16	1.33	1.45	1.49	1.52	1.56	1.60	1.67	1.78
10	.85	.96	1.12	1.31	1.50	1.75	2.02	2.17	2.32	2.49	2.67	2.87	3.14
15	.98	1.12	1.30	1.50	1.74	2.00	2.34	2.52	2.72	2.92	3.14		
20	1.07	1.25	1.42	1.68	1.92	2.25	2.58	2.80	3.00				
25	1.15	1.34	1.55	1.82	2.12	2.45	2.80	3.05					
30	1.23	1.43	1.65	1.94	2.24	2.60	2.99	3.27					
35	1.28	1.50	1.72	2.03	2.32	2.70	3.15						
40	1.36	1.54	1.80	2.14	2.48	2.85	3.28						
45	1.41	1.64	1.89	2.22	2.58	2.95	3.46						
50	1.46	1.70	1.97	2.30	2.68	3.15							
55	1.50	1.74	2.00	2.37	2.76	3.20							
60	1.55	1.81	2.10	2.46	2.84	3.28							
65	1.60	1.85	2.17	2.53	2.92	3.40							
70	1.63	1.90	2.19	2.56	3.00								

ASD TR 61-191(II)

III-67

TABLE III A-47
 LINEAR STRETCH FORMING LIMITS
 HEEL-IN RAT SECTIONS
 HASTELLOY X
 (SOLUTION TREATED)

Contour Radius R_c	Material Thickness (t)												
	.016	.020	.025	.032	.040	.050	.063	.071	.080	.090	.100	.125	.187
	Section Height Limits (h)												
5	.60	.69	.80	.93	1.07	1.22	1.29	1.33	1.35	1.37	1.41	1.47	1.54
10	.76	.88	1.02	1.20	1.37	1.57	1.81	1.97	2.11	2.29	2.43	2.62	2.75
15	.88	1.02	1.17	1.37	1.59	1.82	2.13	2.27	2.46	2.65	2.83	3.25	
20	.98	1.14	1.30	1.53	1.76	2.05	2.36	2.56	2.74	2.99	3.18		
25	1.06	1.23	1.42	1.66	1.91	2.21	2.56	2.77	2.99	3.24			
30	1.12	1.30	1.50	1.76	2.04	2.35	2.71	2.98	3.20				
35	1.18	1.36	1.57	1.86	2.16	2.50	2.90	3.12					
40	1.24	1.43	1.65	1.95	2.26	2.60	3.00						
45	1.28	1.49	1.72	2.02	2.34	2.70	3.15						
50	1.34	1.54	1.80	2.11	2.47	2.85	3.28						
55	1.38	1.60	1.85	2.18	2.52	2.95	3.40						
60	1.42	1.65	1.90	2.24	2.60	3.00							
65	1.46	1.70	1.97	2.30	2.68	3.10							
70	1.50	1.73	2.00	2.37	2.72	3.20							

TABLE III A-4.8
 LINEAR STRETCH FORMING LIMITS
 HEEL-IN HAT SECTIONS
 L-605
 (SOLUTION TREATED)

Contour Radius R_c	Material Thickness (t)												
	.016	.020	.025	.032	.040	.050	.063	.071	.080	.090	.100	.125	.187
	Section Height Limits (h)												
5	.61	.70	.82	.95	1.09	1.20	1.27	1.31	1.34	1.37	1.40	1.46	1.55
10	.77	.90	1.04	1.21	1.40	1.61	1.86	2.02	2.16	2.32	2.38	2.50	2.71
15	.90	1.04	1.20	1.39	1.62	1.86	2.17	2.31	2.51	2.71	2.87	3.31	
20	.99	1.15	1.32	1.55	1.79	2.08	2.39	2.59	2.78	3.03			
25	1.07	1.23	1.43	1.68	1.93	2.25	2.59	2.80	3.04				
30	1.14	1.32	1.52	1.81	2.08	2.40	2.78	3.02					
35	1.18	1.36	1.59	1.89	2.18	2.51	2.91	3.16					
40	1.25	1.44	1.67	1.97	2.26	2.65	3.06						
45	1.30	1.50	1.75	2.08	2.36	2.75	3.21						
50	1.34	1.57	1.80	2.14	2.48	2.85	3.34						
55	1.39	1.61	1.87	2.20	2.56	3.00							
60	1.44	1.66	1.92	2.27	2.64	3.10							
65	1.47	1.70	2.00	2.34	2.68	3.15							
70	1.50	1.74	2.02	2.40	2.76	3.20							

ASD TR 61-191(II)

III-69

TABLE III A-49
 LINEAR STRETCH FORMING LIMITS
 HEEL-IN HAT SECTIONS
 COLUMBIUM (10Mo-10Ti)

Contour Radius R_c	Material Thickness (t)												
	.016	.020	.025	.032	.040	.050	.063	.071	.080	.090	.100	.125	.187
	Section Height Limits (h)												
5	.37	.43	.46	.50	.53	.54	.56	.57	.58	.59	.60	.62	.62
10	.46	.55	.64	.74	.86	.92	.99	1.02	1.04	1.06	1.08	1.14	1.18
15	.54	.62	.72	.85	.97	1.12	1.31	1.35	1.40	1.42	1.45	1.54	1.64
20	.59	.69	.80	.93	1.08	1.25	1.45	1.58	1.68	1.84	1.88	1.94	2.06
25	.64	.74	.87	1.01	1.17	1.36	1.57	1.70	1.86	2.01	2.16	2.31	2.49
30	.69	.80	.92	1.09	1.26	1.45	1.70	1.85	2.00	2.13	2.30	2.62	2.95
35	.72	.84	.96	1.14	1.32	1.52	1.76	1.92	2.08	2.25	2.40	2.79	3.27
40	.75	.87	1.00	1.18	1.38	1.60	1.82	1.99	2.16	2.34	2.50	2.90	3.55
45	.78	.90	1.05	1.23	1.42	1.65	1.95	2.06	2.26	2.43	2.64	3.00	
50	.82	.94	1.10	1.28	1.49	1.73	2.02	2.20	2.36	2.54	2.75	3.15	
55	.84	.96	1.12	1.34	1.52	1.80	2.08	2.27	2.42	2.61	2.84	3.25	
60	.86	1.00	1.16	1.37	1.60	1.85	2.15	2.34	2.54	2.70	2.90	3.37	
65	.89	1.02	1.20	1.41	1.64	1.87	2.20	2.39	2.56	2.79	3.00		
70	.90	1.05	1.22	1.44	1.68	1.95	2.27	2.43	2.64	2.88	3.08		

ASD TR 61-191(TI)

III-70

TABLE III A-50
 LINEAR STRETCH FORMING LIMITS
 HEEL-IN HAT SECTIONS
 MOLYBDENUM (.5% Ti)
 (HOT ROLLED STRESS RELIEVED AND DE-SCALED)

Contour Radius Rc	Material Thickness (t)												
	.016	.020	.025	.032	.040	.050	.063	.071	.080	.090	.100	.125	.187
	Section Height Limits (h)												
5	.37	.43	.49	.53	.57	.58	.60	.62	.63	.65	.66	.67	.67
10	.46	.55	.64	.74	.86	.97	1.04	1.09	1.11	1.13	1.16	1.22	1.27
15	.54	.62	.72	.85	.97	1.12	1.31	1.42	1.52	1.56	1.59	1.67	1.79
20	.59	.69	.80	.93	1.08	1.25	1.45	1.58	1.68	1.84	1.97	2.12	2.24
25	.64	.74	.87	1.01	1.17	1.36	1.57	1.70	1.86	2.01	2.16	2.46	2.67
30	.69	.80	.92	1.09	1.26	1.45	1.70	1.85	2.00	2.13	2.30	2.62	3.12
35	.72	.84	.96	1.14	1.32	1.52	1.76	1.92	2.08	2.25	2.40	2.79	3.51
40	.75	.87	1.00	1.18	1.38	1.60	1.82	1.99	2.16	2.34	2.50	2.90	3.74
45	.78	.90	1.05	1.23	1.42	1.65	1.95	2.06	2.26	2.43	2.64	3.00	
50	.82	.94	1.10	1.28	1.49	1.73	2.02	2.20	2.36	2.54	2.75	3.15	
55	.84	.96	1.12	1.34	1.52	1.80	2.08	2.27	2.42	2.61	2.84	3.25	
60	.86	1.00	1.16	1.37	1.60	1.85	2.15	2.34	2.54	2.70	2.90	3.37	
65	.89	1.02	1.20	1.41	1.64	1.87	2.20	2.39	2.56	2.79	3.00		
70	.90	1.05	1.22	1.44	1.68	1.95	2.27	2.43	2.64	2.88	3.08		

TABLE III A-51
 LINEAR STRETCH FORMING LIMITS
 HEEL-IN HAT SECTIONS
 J-1570
 (SOLUTION TREATED)

Contour Radius R_c	Material Thickness (t)												
	.016	.020	.025	.032	.040	.050	.063	.071	.080	.090	.100	.125	.187
	Section Height Limits (h)												
5	.60	.70	.82	.94	1.10	1.25	1.31	1.35	1.38	1.40	1.44	1.50	1.59
10	.78	.90	1.05	1.24	1.40	1.62	1.88	2.03	2.16	2.34	2.52	2.59	2.86
15	.90	1.04	1.21	1.34	1.64	1.87	2.17	2.34	2.52	2.72	2.90	3.35	
20	1.00	1.16	1.32	1.57	1.80	2.10	2.41	2.63	2.80	3.06			
25	1.08	1.25	1.45	1.70	1.96	2.25	2.61	2.84	3.08				
30	1.15	1.32	1.55	1.81	2.10	2.42	2.80	3.05					
35	1.19	1.38	1.62	1.90	2.18	2.55	2.96	3.19					
40	1.26	1.45	1.70	2.00	2.32	2.67	3.09						
45	1.31	1.54	1.76	2.08	2.40	2.75	3.21						
50	1.36	1.59	1.82	2.18	2.50	2.85	3.37						
55	1.40	1.64	1.90	2.22	2.60	3.00							
60	1.44	1.70	1.95	2.30	2.68	3.10							
65	1.47	1.72	2.00	2.37	2.72	3.20							
70	1.52	1.76	2.05	2.40	2.76	3.25							

ASD TR 61-191(II)

III-72

LINEAR ROLL FORMING

Description of Process

The linear roll process is used to contour angle and channel parts of both extruded and brake formed sheet metal sections. For the purpose of this evaluation sheet metal channels were formed. When angle sections are desired, a channel can be formed and split down the web thus providing two angle sections.

There are several types of linear roll machines available but the one used in this evaluation was a three roll Kane and Roach rolling machine. This machine was chosen for use because very simple tooling can be utilized to form channel sections. Tooling consists simply of circular rolls machined to the desired dimensions. A schematic of roll tooling is shown in the following sketch:

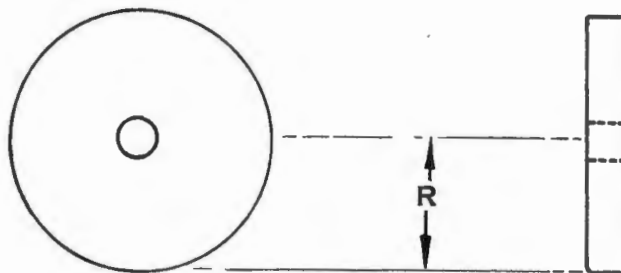

FIGURE III B-1 LINEAR ROLL TOOLING

Due to the nature of the linear roll process, handwork is required on practically all sheet metal parts formed by this process, especially if close dimensional tolerances are required. In cases where close web and flange tolerances are essential it is recommended that the parts be formed by the linear stretch process.

There are many uncontrollable variables associated with the linear roll process. Included in these variables are: Material property variations, lateral flange support, bending pressure to produce contouring, work hardening and operator technique. The successful fabrication of a quality part is dependent to a great extent upon the skill of the operator. Not only does the operator have to have a feel for the particular material he is forming, but he must also determine the amount of lateral flange support to be used, as well as the amount of bending pressure to produce contouring.

As a rule, only the heavier gage materials are formed by the linear roll process; however, the lighter gages, .020 - .040, are often formed but extreme care must be exercised by the operator to produce parts of good quality. Parts formed by this process are formed in increments and it may take several passes to reach the desired part radius. The thinner gage materials have less section rigidity and as a result, have a tendency to collapse when too much lateral flange support or bending pressure is applied.

A typical three roll heel-in machine set-up is shown in Figure III B-2. The rolling tools C_1 and C_2 are machined to the dimensions dictated by the configuration of the channel to be formed. The rolls are to be of sufficient radius to accommodate the channel section height and their width is governed by the width of the web of the channel. The rolling tools are power driven and supply the motion to move the channel. A third roll, A, is used to supply pressure to the web of the channel so that contouring can be accomplished as the channel, D, is passed through the rolls C_1 and C_2 . The lateral support blocks, B_1 and B_2 are fastened to the shaft of the roll machine on each side of the roll tooling. Their purpose is to eliminate flange spreading under the bending pressure exerted by roll A. E_1 and E_2 are shims to provide spacing between the lateral support blocks and the channel being formed. The shims are the same gage as the channel being formed.

The primary failure encountered in the heel-in process is transverse buckling; however, there are other flange and web distortions common to the process. Among these distortions are web crowning, web widening, and flange spreading. These distortions are considered minor except in severe cases where it is obvious that their presence is brought about by stresses that ordinarily cause buckling. The severity of web crowning and flange spreading increases in materials having low values of E/S_{ty} , particularly in Titanium, Columbium, and Vascojet 1000. In these materials having low values of E/S_{ty} transverse buckling becomes less pronounced but flange spreading and plate buckling become more pronounced.

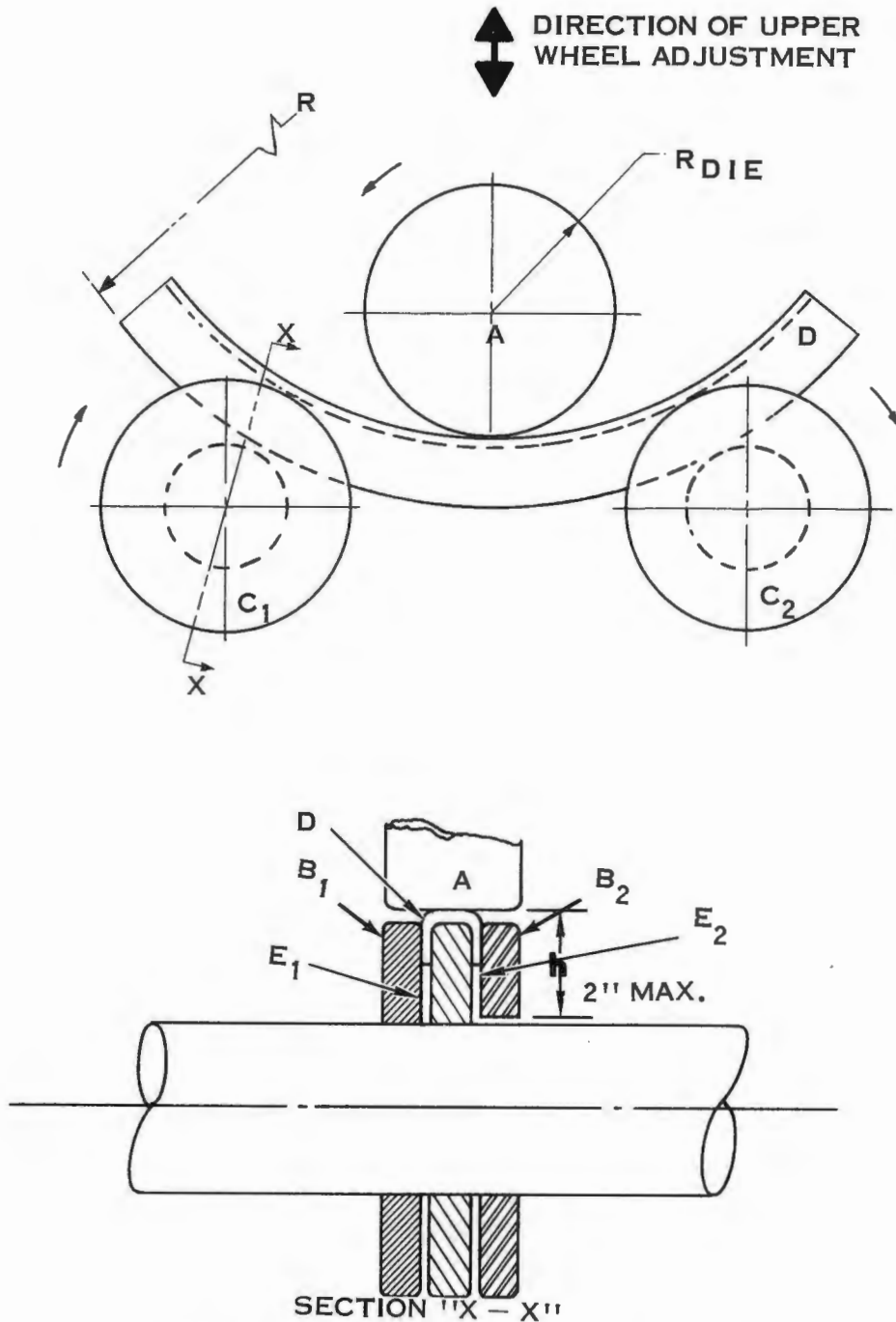

SECTION "X - X"
 LINEAR ROLL HEEL-IN MACHINE SET-UP
 FIGURE III B-2

Another limitation of the linear roll heel-in process is a progressive build-up of material in the bend radius area of the channel. See Figure III B-3. This build-up is characteristic of the more ductile materials such as aluminum. It does not necessarily affect the structural characteristics of the part; however, due to this build-up the web of the channel widens. As the web widens the original bend radius is reduced. This occurrence increases in severity with a reduction in part radius and is more characteristic of the heavier gages and should be considered when selecting a forming process. If the structural application of the part is such that a definite bend radius is required, it is recommended that another flanging process be used. In most cases the alternate process would be the linear stretch process.

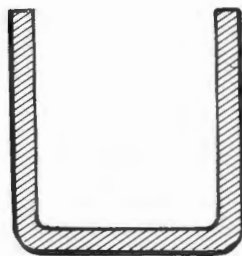

BEFORE FORMING

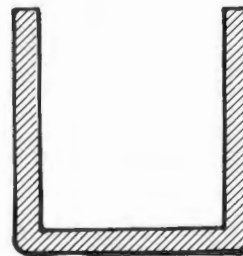

AFTER FORMING

FIGURE III B-3 HEEL-IN CHANNEL DISTORTION

The limitations of the linear roll heel-out process are much the same as previously described for the heel-in process; however, the quality of parts produced by this process is usually superior to the quality of heel-in parts.

The primary failure encountered in forming heel-out channels is compression wrinkling or buckling of the flanges. There are other section distortions such as crowning in the web, flange spreading and web buckling; however, these secondary failures are considered minor.

The linear roll heel-out process is similar to the heel-in process. It employs incremental type forming and the successful operation is highly dependent upon the skill of the operator. As with heel-in forming, there are many uncontrollable variables associated with this process which makes duplication of results very difficult. The most important mechanical variables that must be controlled by the operator are the amount of lateral support for the flanges and the amount of bending pressure supplied to produce contouring. For heel-out channels, insufficient lateral support will cause "grabbing" in the rolls resulting in either a destroyed part or an uneven contour radius. The amount of bending pressure is also important to the forming of heel-out sections. Too much bending pressure will cause either premature flange wrinkling, crowning in the web or a collapse of the section. The amount of lateral flange support and bending pressure required will vary with the particular material being formed. The softer materials require less pressure to produce contouring, therefore it is necessary for the operator to apply less bending pressure to minimize the chances of premature part failure.

Definition of Part Shape and Geometric Variables

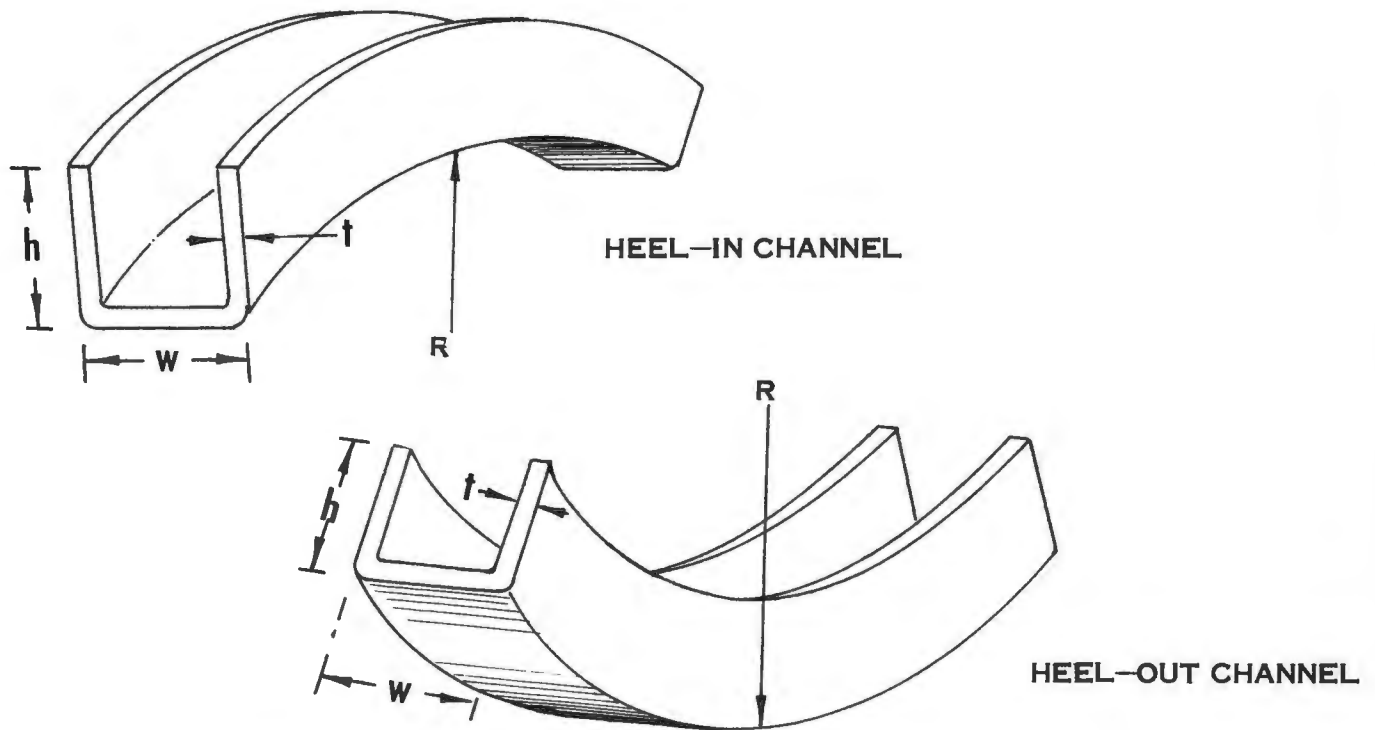

FIGURE III B-4 LINEAR ROLL HEEL-IN AND HEEL-OUT CHANNELS

Linear roll heel-in and heel-out channels are linear sections prepared from sheet metal stock by brake forming the sheet metal to the desired section height and web width, then roll forming to the desired contour radius. Linear roll heel-in channels are used where it is necessary to fasten the section to a convex surface of a structure whereas heel-out sections are fastened to concave surfaces of a structure.

Parts formed by the linear roll process can be formed to a constant radius or in many cases, parts with varying radii can be formed with relative ease. No special tooling is required for parts with varying radii; however, the machine operator must be supplied with a template representing the various radii to be formed.

The geometric variables, as shown in Figure III B-4, are material thickness (t), section height (h), contour radius (R) and web width (w). The material thickness, section height, and contour radius are the only variables considered in this evaluation; however, web width can be a limiting parameter for formability limits of the lighter gage materials. A web width of .75" is satisfactory for the material gages used in this evaluation, but this web width is considered maximum for .020 and lighter gage materials.

Predictability Equations

Heel-in Channel:

The equation for the inflection line:

$$\boxed{\frac{h}{R} = 0.0146 \left(\frac{h}{t} \right)^{\frac{1}{2}}}$$

Equation I

The equation for the elastic buckling line:

$$\boxed{\frac{h}{R} = \frac{E}{S_{ty}} \left[\frac{0.025}{\left(\frac{h}{t} \right)^2} \right]}$$

Equation II

The equation for the buckling line above the inflection line:

$$\frac{h}{t} = \left[1.713 \frac{E}{S_{ty}} \right]^{\frac{2}{5}} \quad \text{Equation III}$$

Heel-Out Channels:

The equation for the inflection line:

$$\frac{h}{R} = 0.0209 \left(\frac{h}{t} \right)^{\frac{1}{2}} \quad \text{Equation IV}$$

The equation for elastic buckling:

$$\frac{h}{R} = \frac{E}{S_{cy}} \left[\frac{0.02116}{\left(\frac{h}{t} \right)^2} \right] \quad \text{Equation V}$$

The equation for buckling above the inflection line:

$$\frac{h}{t} = \left[1.01 \frac{E}{S_{cy}} \right]^{\frac{2}{5}} \quad \text{Equation VI}$$

The formability equations and curve shapes for both heel-in and heel-out channels are basically the same. Due to this similarity only the equations and formability curves for heel-in sections will be discussed.

To construct a formability curve for heel-in channels using the predictability equations, the following procedure is followed.

As an example, the formability curve for 2024-O aluminum will be constructed. To construct the formability curve it is necessary to obtain the E/S_{ty} value for the material in question. This property for 2024-O aluminum is $E/S_{ty} = 900$.

Step I: Using Equation I: $h/R = .0146 (h/t)^{\frac{1}{2}}$, locate the position of the inflection line by positioning the point, $h/R = .0146$, on the $h/t = 1$ line. From this point construct a line with a slope of $\frac{1}{2}$. See Figure III B-5.

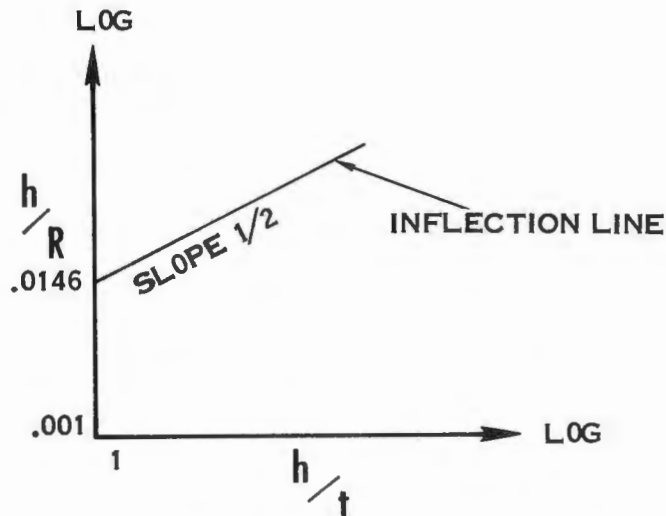

FIGURE III B-5 GRAPH CONSTRUCTION

Step II: Using Equation II: $h/R = E/S_{ty} \left[\frac{.025}{(h/t)^2} \right]$:

Insert the value of E/S_{ty} and arbitrarily select a value for h/t and solve for h/R . Locate the point on log-log graph paper and construct a -2 slope through this point to the h/t axis and to the inflection line. From the inflection line construct a vertical line to the machine limit line. See the following sketch.

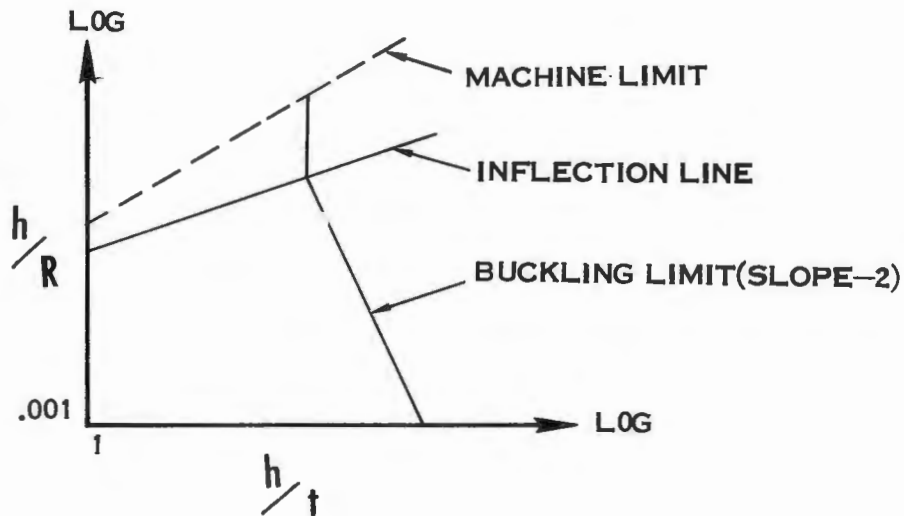

FIGURE III B-6 GRAPH CONSTRUCTION

The machine limit line is a mechanical limit and has nothing to do with material properties; however, it is a limiting parameter. The limit will depend on the material gage, the maximum section height that the tooling will accommodate, and the minimum part radius that the machine and tooling will produce. The machine limit line will have a different position with a change in any of the previously mentioned variables. The machine limit line presented in this report is constructed using the following limiting parameters: 5" minimum obtainable part radius, .063 gage material, and 2" maximum section height. The plot of points on the h/R axis was accomplished by keeping $R = 5$ " constant and varying h to a maximum of 2". Points on the h/t axis were plotted by keeping the material thickness, $t = .063$, constant and varying h to a maximum of 2".

A complete formability curve constructed from the formability equations and the machine limit line is shown in the following sketch.

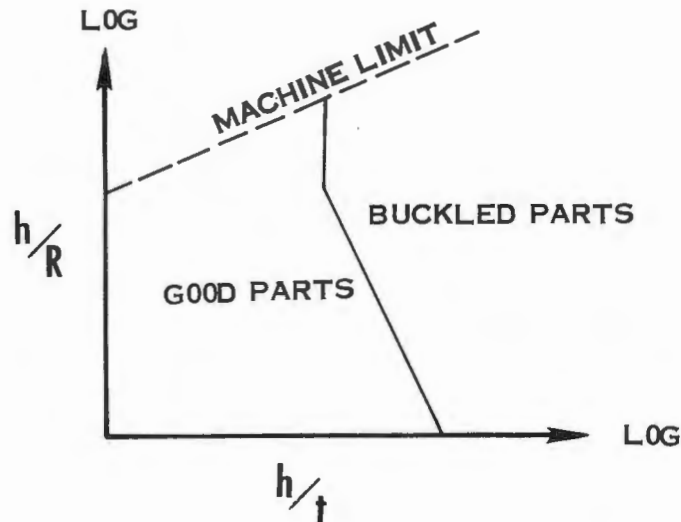

FIGURE III B-7 TYPICAL FORMABILITY CURVE

An alternate method for constructing a formability curve for linear roll section is as follows:

Step I: Construct the inflection line as described in the first method.

Step II: Locate $E/S_{ty} \times 10^{-5}$ on the vertical index line. This index line is $h/t = 50$ for heel-in channels. The value for $E/S_{ty} \times 10^{-5}$ for 2024-0 aluminum is .009. Construct a line with a (-2) slope through this point to the inflection line. From the intersection of this line and the inflection line construct a vertical line to the machine limit line as shown in the following sketch.

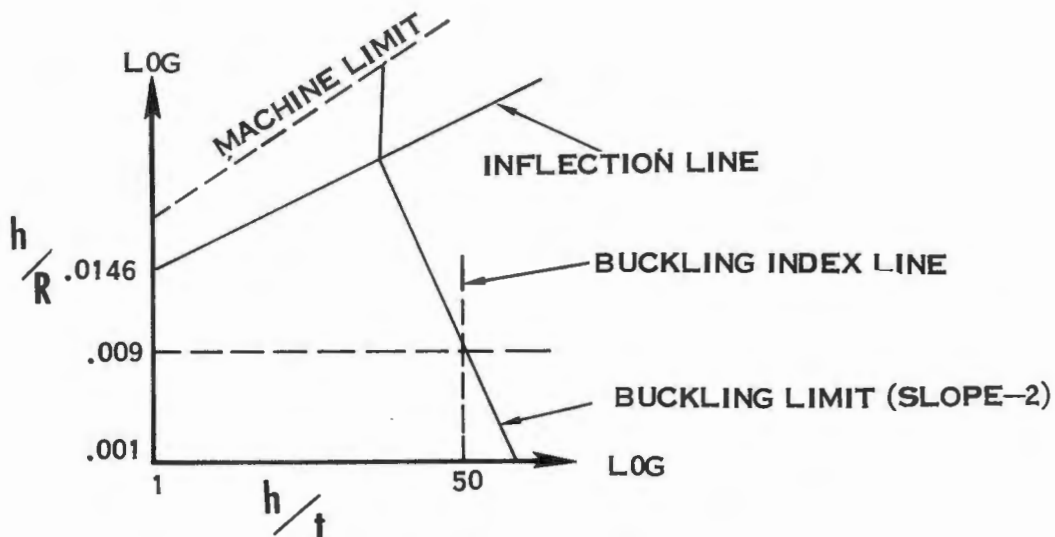

FIGURE III B-8 GRAPH CONSTRUCTION

Composite Graphs

The formability curves representing the forming limits of all materials evaluated under this contract will appear in composite form in Graphs III B-1 and III B-2. Graph III B-1 is the composite for linear roll heel-in channels and Graph III B-2 is the composite for heel-out channels.

All individual graphs and composite graphs have been presented on a logarithmic basis; however, a method of plotting design limits on Cartesian graph paper is possible. To construct this type graph it is necessary to have previously determined the formability limits of the material in question. A plot of maximum section height versus minimum contour radius for any material thickness is made on Cartesian graph paper as illustrated in Graph III B-3. This type graph enables the planner or designer to read design limits directly with no calculations necessary.

**GRAPH III B-1
LINEAR ROLL COMPOSITE GRAPH
HEEL-IN CHANNELS**

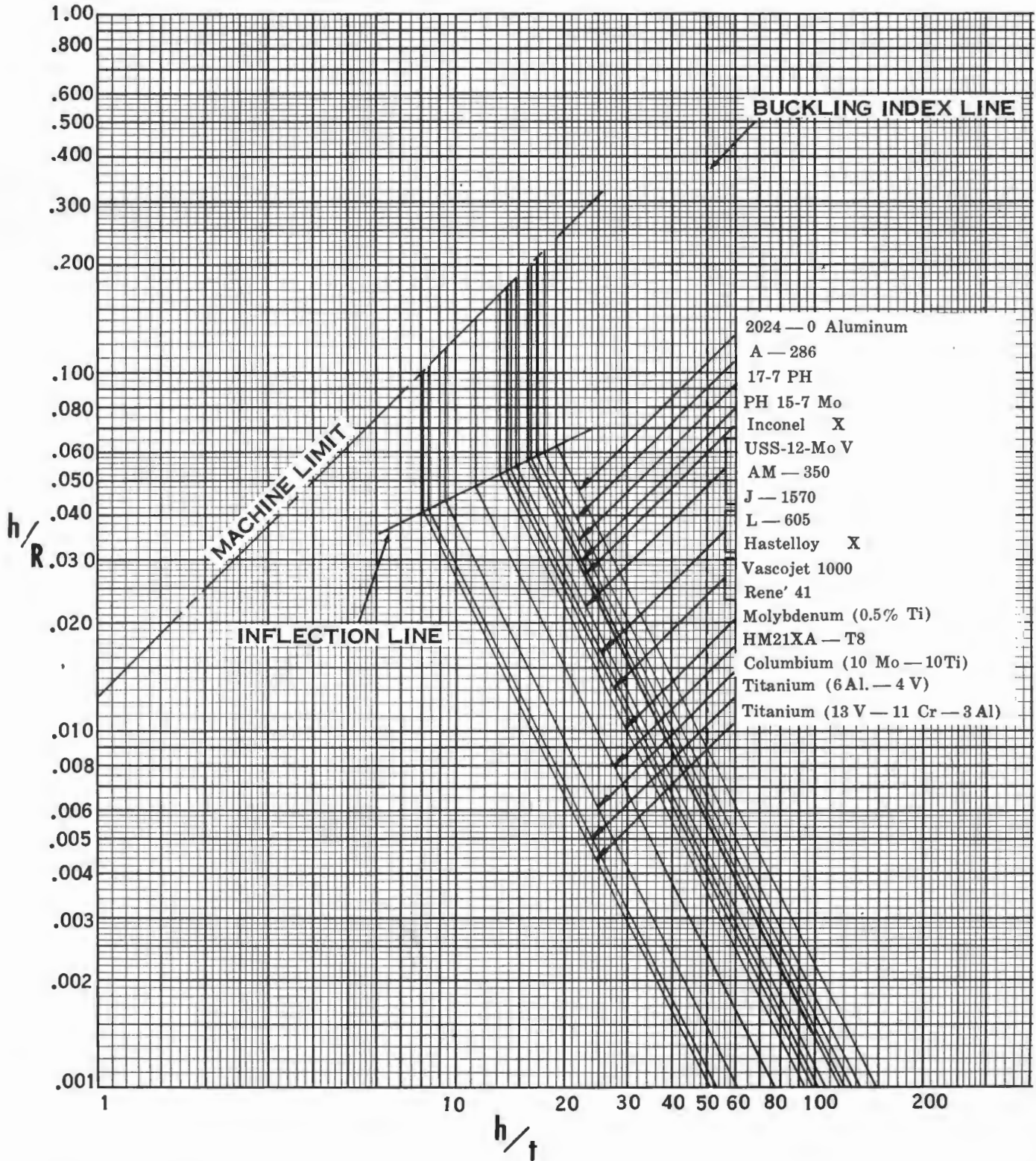

GRAPH III B-2
 LINEAR ROLL COMPOSITE GRAPH
 HEEL-OUT CHANNELS

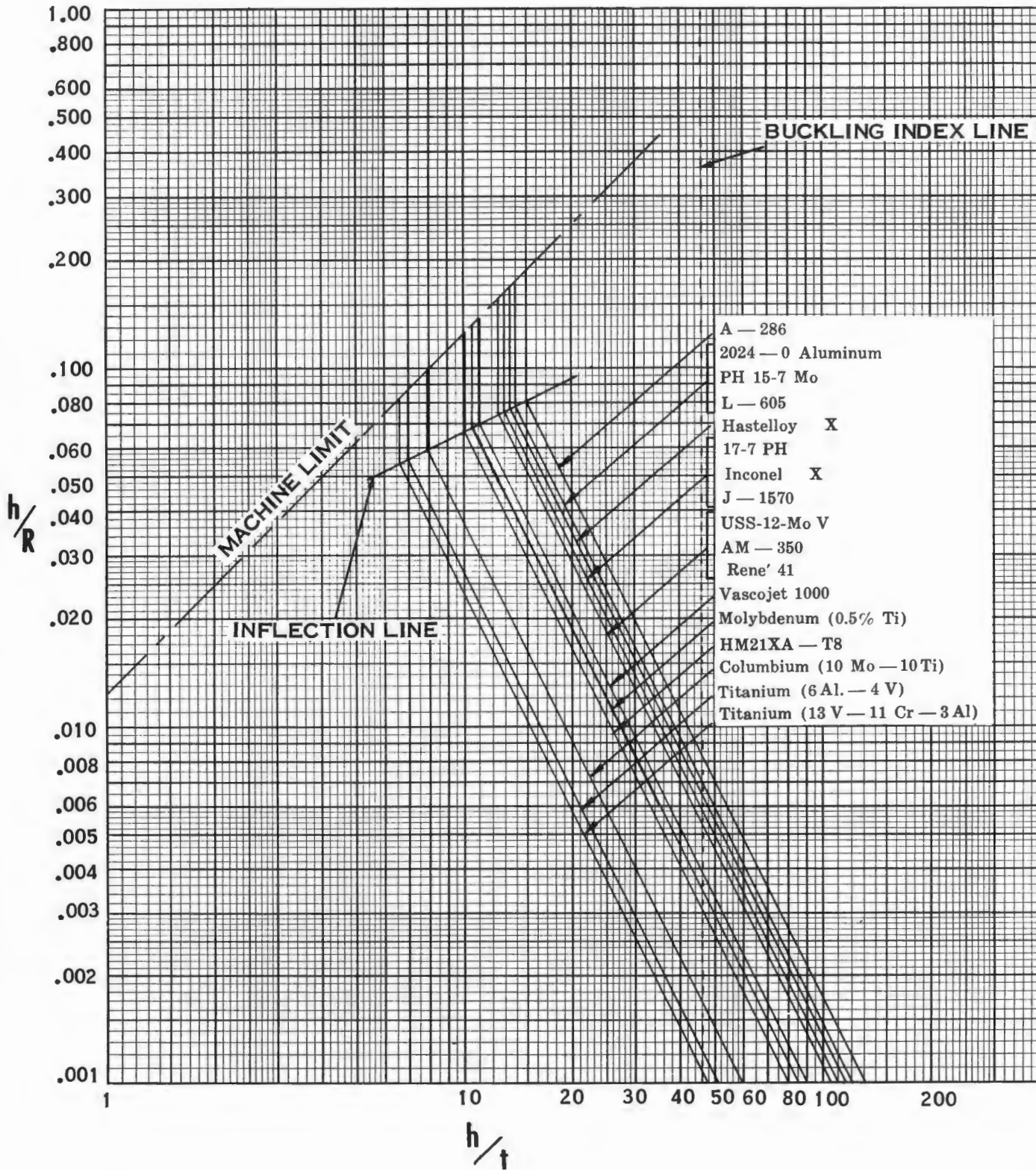

GRAPH III B-3

ALTERNATE METHOD FOR PLOTTING LINEAR ROLL
HEEL-IN - 17-7 PH (CONDITION "A")

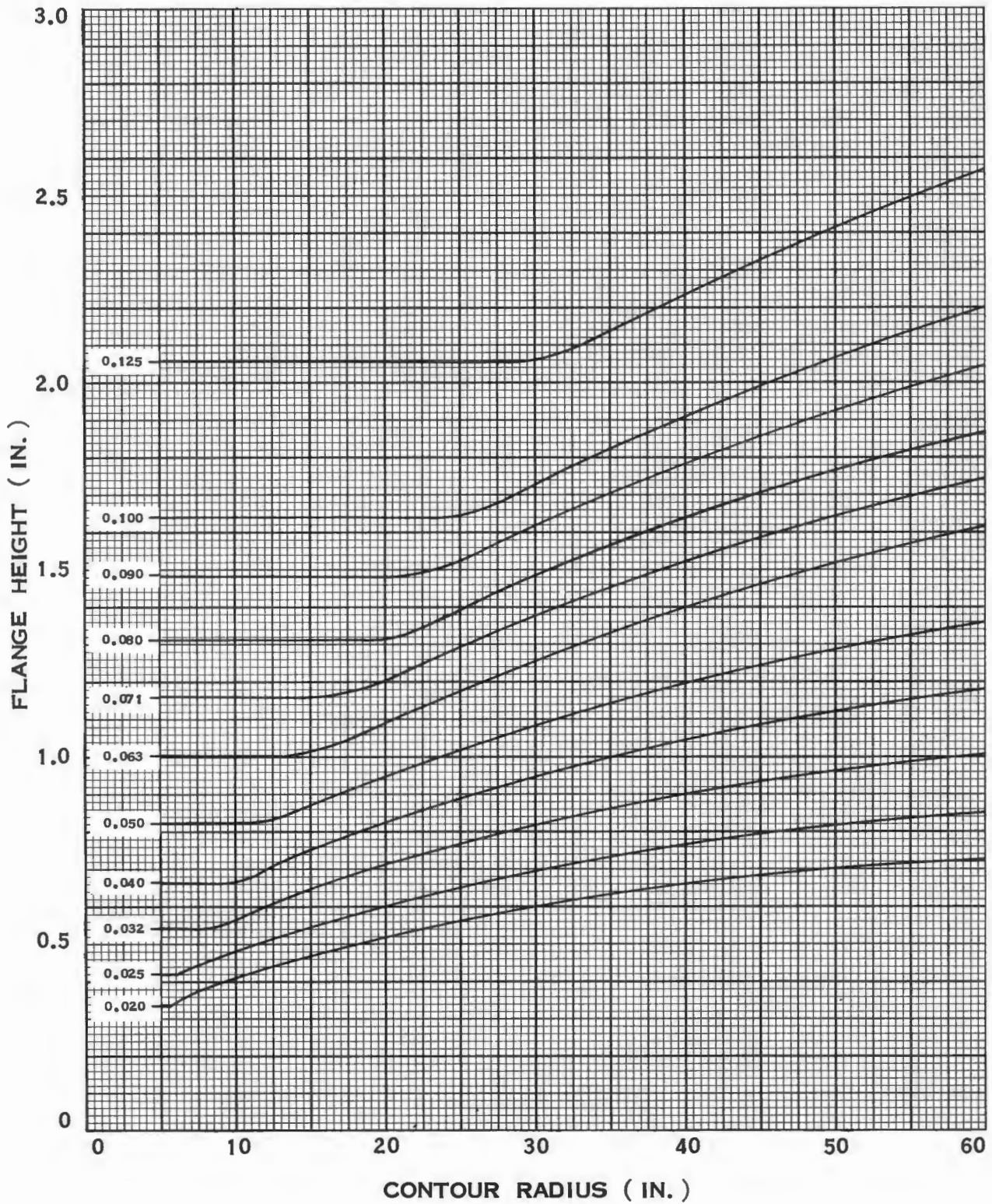

Design Tables

The design tables presented in this report are derived from the composite graphs presented in the previous section. The design limits for linear roll heel-in channels appear in Tables III B-1 through III B-17, and the design limits for heel-out channels appear in Tables III B-18 through III B-34.

Due to the nature of the linear roll heel-in process it is very difficult to form parts with practical section heights that are perfectly free of buckling and require no handwork. Because of this a certain amount of handworkable buckling is tolerated and the design limits presented for heel-in channels may include parts with transverse buckles to approximately .02" in depth as shown in the following sketch.

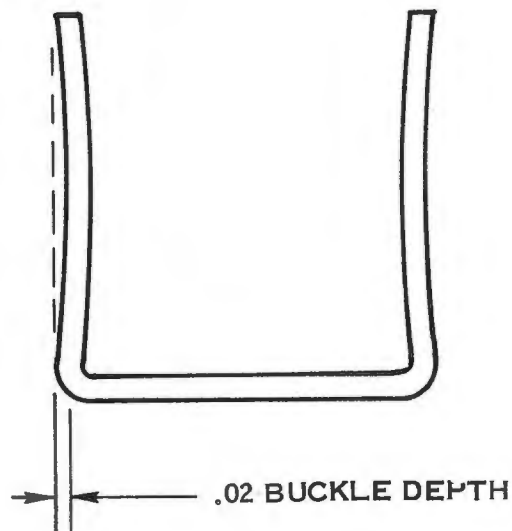

FIGURE III B-9 HEEL-IN CHANNEL DISTORTION

The formability limits for heel-out channels are based on incipient flange buckling. For design purposes these limits can be exceeded where handwork is applicable. The maximum amount of handwork that can be tolerated will depend on the tolerance requirements and structural application of the individual part.

It is possible, especially for heavy gage materials, to extend the formability limits for heel-out channels. This may be accomplished by tightening the gap between the roll tool and the flange support blocks so that there is less clearance in which the flanges may buckle. This procedure is actually a procedure of in-process handwork and is done at the risk of destroying the channel. As the channel is roll formed to a contour radius that exceeds the theoretical buckling limit small buckles will appear in the flanges. In some cases, the contour radius may be decreased considerably after the buckling limit is reached; however, the scrap rate can be expected to be high. The small buckles that appear in the flanges may cause "grabbing" in the roll tooling resulting in either an uneven contour radius or a completely collapsed part.

The following design tables are so constructed that the maximum section height can be determined for any practical combination of material thickness and contour radius. For linear roll sections the practical range of material gage is .020 - .187, and the practical range of part radii is $R = 5'' - R = 70''$.

The composite graphs and design tables for tungsten and beryllium are not shown for the linear roll process. The extreme brittleness of these materials at room temperature makes room temperature forming impossible.

The design limits for .016 material are excluded for all materials because of the high scrap rate that can be expected of the lighter gage materials using the three roll linear roll process. The other vacant areas in the design tables are due to a limitation imposed by the tooling and machine design.

The following design limits are established for channel sections formed on a Kane and Roach three roll linear roll machine.

TABLE III B-1
 LINEAR ROLL FORMING LIMITS
 HEEL-IN CHANNELS
 HM21XA-T8 (MAGNESIUM THORIUM)

Contour Radius R	Material Thickness (t)												
	.016	.020	.025	.032	.040	.050	.063	.071	.080	.090	.100	.125	.187
	Section Height Limits (h)												
5		.24	.28	.37	.44	.55	.70	.79					
10		.30	.34	.42	.48	.55	.70	.79	.89	1.00	1.11	1.39	
15		.34	.39	.48	.54	.63	.74	.79	.89	1.00	1.11	1.39	2.06
20		.37	.43	.53	.60	.69	.81	.87	.95	1.02	1.11	1.39	2.06
25		.40	.46	.56	.64	.74	.87	.93	1.03	1.10	1.19	1.39	2.06
30		.42	.50	.60	.68	.79	.91	.99	1.08	1.16	1.25	1.46	2.06
35		.45	.52	.63	.72	.84	.97	1.06	1.13	1.23	1.32	1.53	2.06
40		.47	.54	.66	.74	.86	1.01	1.08	1.18	1.27	1.38	1.60	2.06
45		.48	.56	.68	.77	.90	1.06	1.13	1.23	1.34	1.42	1.66	2.19
50		.51	.59	.72	.80	.94	1.10	1.19	1.28	1.39	1.50	1.75	2.26
55		.52	.60	.74	.82	.96	1.13	1.22	1.32	1.44	1.53	1.79	2.34
60		.54	.62	.76	.84	.99	1.16	1.25	1.36	1.47	1.58	1.84	2.39
65		.55	.64	.78	.86	1.00	1.19	1.28	1.38	1.52	1.61	1.89	2.45
70		.56	.66	.80	.90	1.04	1.21	1.31	1.43	1.54	1.67	1.90	2.52

ASD TR 61-191(II)

III-93

TABLE III B-2
 LINEAR ROLL FORMING LIMITS
 HEEL-IN CHANNELS
 2024-O ALUMINUM

Contour Radius R	Material Thickness (t)												
	.016	.020	.025	.032	.040	.050	.063	.071	.080	.090	.100	.125	.187
	Section Height Limits (h)												
5		.37	.46	.59	.73	.92	1.15	1.30	1.47				
10		.46	.53	.62	.73	.92	1.15	1.30	1.47	1.65	1.83	2.29	
15		.52	.60	.71	.82	.96	1.15	1.30	1.47	1.65	1.83	2.29	3.42
20		.56	.65	.77	.90	1.05	1.23	1.35	1.47	1.65	1.83	2.29	3.42
25		.60	.73	.83	.96	1.14	1.32	1.43	1.55	1.70	1.83	2.29	3.42
30		.64	.75	.91	1.02	1.20	1.39	1.50	1.63	1.76	1.80	2.29	3.42
35		.68	.77	.93	1.08	1.25	1.46	1.59	1.72	1.87	2.00	2.35	3.42
40		.71	.82	.97	1.12	1.31	1.54	1.66	1.79	1.96	2.10	2.44	3.42
45		.74	.86	1.01	1.18	1.36	1.61	1.74	1.88	2.05	2.20	2.55	3.42
50		.77	.89	1.07	1.24	1.43	1.61	1.80	1.95	2.12	2.29	2.65	3.42
55		.78	.90	1.08	1.26	1.45	1.70	1.85	2.00	2.18	2.32	2.74	3.55
60		.82	.95	1.12	1.31	1.51	1.78	1.92	2.08	2.25	2.41	2.81	3.68
65		.83	.96	1.14	1.32	1.53	1.79	1.95	2.10	2.39	2.45	2.86	3.74
70		.85	.99	1.16	1.35	1.55	1.84	1.98	2.15	2.33	2.50	2.89	3.81

TABLE III B-3
 LINEAR ROLL FORMING LIMITS
 HEEL-IN CHANNELS
 17-7 PH (CONDITION A)

ASD TR 61-191(II)

III-95

Contour Radius R	Material Thickness (t)												
	.016	.020	.025	.032	.040	.050	.063	.071	.080	.090	.100	.125	.187
	Section Height Limits (h)												
5		.33	.41	.52	.66	.82	1.03	1.16					
10		.41	.48	.57	.66	.82	1.03	1.16	1.31	1.48	1.64	2.05	
15		.47	.55	.64	.76	.88	1.03	1.16	1.31	1.48	1.64	2.05	3.07
20		.52	.60	.71	.82	.95	1.13	1.21	1.31	1.48	1.64	2.05	3.07
25		.54	.65	.76	.88	1.02	1.20	1.29	1.42	1.53	1.64	2.05	3.07
30		.58	.68	.80	.93	1.09	1.26	1.37	1.50	1.62	1.74	2.05	3.07
35		.62	.72	.85	.99	1.15	1.33	1.45	1.58	1.71	1.82	2.13	3.07
40		.65	.75	.89	1.04	1.20	1.41	1.51	1.65	1.80	1.91	2.25	3.07
45		.67	.78	.91	1.07	1.25	1.45	1.57	1.70	1.85	2.00	2.32	3.07
50		.70	.81	.96	1.12	1.30	1.51	1.63	1.76	1.92	2.06	2.40	3.18
55		.72	.83	.99	1.14	1.32	1.57	1.70	1.84	1.98	2.11	2.49	3.22
60		.74	.85	1.01	1.18	1.36	1.61	1.73	1.86	2.04	2.20	2.56	3.33
65		.76	.87	1.04	1.20	1.40	1.64	1.77	1.92	2.09	2.25	2.62	3.38
70		.77	.90	1.05	1.23	1.42	1.67	1.81	1.95	2.13	2.30	2.68	3.48

TABLE III B-4
 LINEAR ROLL FORMING LIMITS
 HEEL-IN CHANNELS
 PH 15-7 Mo (CONDITION A)

Contour Radius R	Material Thickness (t)												
	.016	.020	.025	.032	.040	.050	.063	.071	.080	.090	.100	.125	.187
	Section Height Limits (h)												
5		.32	.40	.52	.64	.81	1.01	1.14					
10		.42	.47	.55	.64	.81	1.01	1.14	1.29	1.45	1.61	2.01	
15		.46	.54	.64	.74	.86	1.01	1.14	1.29	1.45	1.61	2.01	3.01
20		.50	.59	.69	.80	.94	1.08	1.19	1.29	1.45	1.61	2.01	3.01
25		.54	.63	.74	.86	1.00	1.18	1.28	1.38	1.49	1.62	2.01	3.01
30		.58	.67	.79	.92	1.06	1.26	1.35	1.46	1.58	1.71	2.01	3.01
35		.60	.70	.83	.96	1.13	1.32	1.43	1.54	1.67	1.80	2.11	3.01
40		.64	.75	.88	1.01	1.18	1.39	1.49	1.61	1.75	1.90	2.19	3.01
45		.66	.76	.90	1.04	1.23	1.43	1.55	1.68	1.81	1.96	2.28	3.01
50		.69	.80	.95	1.11	1.29	1.50	1.62	1.75	1.89	2.02	2.37	3.04
55		.70	.81	.96	1.12	1.30	1.51	1.64	1.79	1.95	2.07	2.44	3.18
60		.72	.85	.99	1.16	1.35	1.57	1.70	1.84	1.99	2.14	2.50	3.25
65		.75	.86	1.02	1.20	1.38	1.61	1.74	1.89	2.05	2.20	2.56	3.37
70		.76	.88	1.04	1.20	1.40	1.64	1.77	1.92	2.08	2.24	2.58	3.44

ASD TR 61-191(II)

III-96

TABLE III B-5
 LINEAR ROLL FORMING LIMITS
 HEEL-IN CHANNELS
 AM-350 (ANNEALED)

Contour Radius R	Material Thickness (t)												
	.016	.020	.025	.032	.040	.050	.063	.071	.080	.090	.100	.125	.187
	Section Height Limits (h)												
5		.30	.37	.48	.60	.75	.94	1.07					
10		.37	.43	.51	.60	.75	.94	1.07	1.20	1.35	1.50	1.83	
15		.42	.50	.58	.68	.79	.94	1.07	1.20	1.35	1.50	1.83	2.81
20		.47	.55	.64	.75	.87	1.02	1.11	1.20	1.35	1.50	1.83	2.81
25		.50	.58	.69	.80	.94	1.08	1.14	1.24	1.35	1.50	1.83	2.81
30		.53	.62	.73	.84	.98	1.14	1.24	1.35	1.45	1.55	1.83	2.81
35		.56	.65	.77	.90	1.05	1.22	1.32	1.43	1.54	1.68	1.94	2.81
40		.59	.68	.81	.93	1.10	1.27	1.38	1.50	1.62	1.75	2.01	2.81
45		.61	.71	.84	.97	1.14	1.32	1.43	1.56	1.69	1.80	2.13	2.81
50		.63	.73	.86	1.00	1.17	1.37	1.46	1.59	1.72	1.85	2.15	2.81
55		.65	.75	.90	1.04	1.20	1.42	1.53	1.66	1.80	1.92	2.25	2.96
60		.67	.77	.93	1.07	1.25	1.46	1.57	1.70	1.82	1.99	2.28	3.10
65		.69	.80	.95	1.10	1.27	1.49	1.62	1.76	1.89	2.03	2.37	3.14
70		.70	.82	.96	1.12	1.30	1.52	1.64	1.78	1.96	2.10	2.42	3.18

TABLE III B-6
 LINEAR ROLL FORMING LIMITS
 HEEL-IN CHANNELS
 A-286 (SOLUTION TREATED)

Contour Radius R	Material Thickness (t)												
	.016	.020	.025	.032	.040	.050	.063	.071	.080	.090	.100	.125	.187
	Section Height Limits (h)												
5		.35	.44	.56	.70	.88	1.10	1.24					
10		.42	.50	.58	.70	.88	1.10	1.24	1.40	1.58	1.75	2.19	
15		.48	.57	.67	.78	.91	1.10	1.24	1.40	1.58	1.75	2.19	3.27
20		.54	.63	.74	.85	1.00	1.17	1.27	1.40	1.58	1.75	2.19	3.27
25		.57	.67	.78	.92	1.06	1.26	1.35	1.38	1.59	1.75	2.19	3.27
30		.60	.70	.83	.96	1.12	1.31	1.42	1.54	1.66	1.80	2.19	3.27
35		.64	.74	.87	1.01	1.19	1.39	1.49	1.62	1.76	1.90	2.22	3.27
40		.67	.78	.91	1.06	1.24	1.45	1.56	1.68	1.84	1.98	2.30	3.27
45		.70	.81	.96	1.11	1.31	1.51	1.64	1.78	1.94	2.08	2.44	3.27
50		.72	.85	1.00	1.16	1.35	1.58	1.70	1.83	1.98	2.13	2.50	3.27
55		.75	.87	1.02	1.20	1.38	1.63	1.77	1.91	2.07	2.21	2.61	3.38
60		.76	.89	1.04	1.21	1.41	1.65	1.78	1.93	2.09	2.26	2.63	3.42
65		.78	.91	1.07	1.24	1.45	1.70	1.84	2.00	2.16	2.31	2.70	3.55
70		.80	.94	1.09	1.28	1.49	1.74	1.87	2.00	2.21	2.36	2.75	3.59

TABLE III B-7
 LINEAR ROLL FORMING LIMITS
 HEEL-IN CHANNELS
 USS-12-Mo V (ANNEALED)

Contour Radius R	Material Thickness (t)												
	.016	.020	.025	.032	.040	.050	.063	.071	.080	.090	.100	.125	.187
	Section Height Limits (h)												
5		.30	.37	.47	.59	.74	.93	1.04					
10		.37	.43	.51	.60	.74	.93	1.04	1.18	1.32	1.47	1.84	
15		.43	.50	.59	.68	.80	.94	1.04	1.18	1.32	1.47	1.84	2.75
20		.46	.54	.64	.74	.86	1.01	1.10	1.20	1.32	1.47	1.84	2.75
25		.50	.58	.68	.80	.94	1.08	1.18	1.28	1.39	1.50	1.84	2.75
30		.53	.62	.73	.85	.99	1.14	1.24	1.37	1.45	1.58	1.85	2.75
35		.56	.65	.77	.90	1.05	1.23	1.32	1.44	1.54	1.67	1.96	2.75
40		.58	.68	.80	.93	1.09	1.27	1.38	1.49	1.62	1.73	2.01	2.75
45		.61	.71	.84	.98	1.15	1.32	1.43	1.58	1.70	1.82	2.12	2.80
50		.64	.74	.88	1.01	1.18	1.38	1.48	1.60	1.75	1.89	2.20	2.86
55		.65	.75	.90	1.05	1.20	1.42	1.53	1.66	1.80	1.92	2.26	2.96
60		.67	.78	.92	1.07	1.24	1.45	1.56	1.69	1.83	1.99	2.28	3.01
65		.68	.80	.94	1.09	1.26	1.47	1.60	1.75	1.87	2.01	2.36	3.06
70		.69	.81	.96	1.15	1.30	1.51	1.63	1.76	1.90	2.06	2.39	3.14

TABLE III B-8
 LINEAR ROLL FORMING LIMITS
 HEEL-IN CHANNELS
 TITANIUM (6Al-4V)
 (MILL ANNEALED)

Contour Radius R	Material Thickness (t)												
	.016	.020	.025	.032	.040	.050	.063	.071	.080	.090	.100	.125	.187
	Section Height Limits (h)												
5		.19	.23	.27	.32	.41	.51						
10		.22	.26	.31	.36	.41	.51	.57	.64	.72	.80	1.02	
15		.26	.30	.36	.42	.48	.57	.61	.67	.74	.82	1.02	1.54
20		.28	.33	.39	.45	.53	.62	.67	.73	.79	.84	1.00	1.50
25		.31	.36	.42	.49	.56	.67	.72	.78	.86	.92	1.07	1.53
30		.32	.38	.45	.52	.61	.70	.77	.82	.90	.96	1.11	1.53
35		.34	.40	.47	.55	.64	.74	.79	.87	.93	1.01	1.19	1.53
40		.36	.41	.48	.56	.65	.76	.83	.89	.97	1.03	1.27	1.59
45		.38	.43	.51	.60	.70	.81	.87	.95	1.03	1.10	1.27	1.68
50		.39	.45	.54	.62	.72	.83	.91	.97	1.06	1.14	1.35	1.74
55		.40	.46	.55	.63	.74	.86	.92	1.01	1.09	1.18	1.36	1.76
60		.41	.48	.57	.65	.76	.89	.96	1.12	1.13	1.21	1.40	1.86
65		.42	.49	.58	.67	.79	.90	.99	1.06	1.16	1.23	1.46	1.88
70		.43	.50	.60	.68	.80	.94	1.01	1.10	1.18	1.28	1.49	1.91

ASD TR 61-191(II)

III-100

TABLE III B-9
 LINEAR ROLL FORMING LIMITS
 HEEL-IN CHANNELS
 TITANIUM (13V-11Cr-3Al) (SOLUTION TREATED)

Contour Radius R	Material Thickness (t)												
	.016	.020	.025	.032	.040	.050	.063	.071	.080	.090	.100	.125	.187
	Section Height Limits (h)												
5		.17	.20	.25	.32	.40	.50						
10		.22	.26	.30	.36	.41	.50	.57	.64	.72	.80	1.00	
15		.25	.30	.35	.40	.47	.55	.60	.65	.72	.80	1.00	1.50
20		.28	.33	.39	.45	.52	.62	.67	.72	.72	.84	1.00	1.50
25		.30	.35	.41	.48	.56	.66	.71	.76	.84	.89	1.04	1.50
30		.32	.28	.44	.52	.60	.70	.76	.82	.88	.95	1.11	1.50
35		.34	.40	.47	.54	.63	.74	.79	.87	.93	1.00	1.17	1.52
40		.36	.41	.49	.56	.65	.77	.84	.90	.97	1.04	1.22	1.59
45		.37	.42	.50	.59	.68	.80	.86	.94	1.00	1.09	1.25	1.65
50		.38	.45	.53	.61	.71	.83	.89	.96	1.05	1.13	1.31	1.72
55		.40	.45	.54	.63	.73	.84	.92	.99	1.07	1.15	1.36	1.76
60		.40	.47	.55	.64	.74	.88	.93	.94	1.10	1.19	1.38	1.80
65		.42	.48	.57	.66	.77	.89	.97	1.05	1.15	1.22	1.43	1.87
70		.42	.49	.58	.67	.77	.91	.99	1.06	1.15	1.24	1.44	1.92

ASD TR 61-191(II)

III-101

TABLE III B-10
 LINEAR ROLL FORMING LIMITS
 HEEL-IN CHANNELS
 VASCOJET 1000 (H-11) (ANNEALED)

Contour Radius R	Material Thickness (t)												
	.016	.020	.025	.032	.040	.050	.063	.071	.080	.090	.100	.125	.187
	Section Height Limits (h)												
5		.28	.34	.44	.55	.69	.87	.98					
10		.35	.40	.48	.56	.69	.87	.98	1.10	1.24	1.30	1.73	
15		.40	.46	.54	.64	.75	.87	.98	1.10	1.24	1.30	1.73	2.58
20		.44	.51	.61	.70	.82	.95	1.04	1.12	1.24	1.30	1.73	2.58
25		.48	.55	.64	.76	.86	1.03	1.13	1.21	1.32	1.41	1.73	2.58
30		.50	.58	.68	.80	.93	1.07	1.17	1.30	1.36	1.48	1.74	2.58
35		.54	.63	.74	.84	.98	1.15	1.26	1.36	1.45	1.58	1.86	2.58
40		.56	.65	.77	.88	1.02	1.20	1.29	1.42	1.53	1.64	1.89	2.58
45		.58	.67	.79	.92	1.08	1.25	1.35	1.46	1.59	1.71	2.00	2.60
50		.60	.69	.83	.96	1.10	1.29	1.38	1.51	1.63	1.77	2.04	2.68
55		.61	.72	.85	.99	1.15	1.33	1.43	1.58	1.71	1.81	2.14	2.79
60		.63	.74	.87	1.02	1.18	1.39	1.48	1.60	1.74	1.89	2.18	2.84
65		.65	.75	.90	1.04	1.21	1.40	1.53	1.66	1.80	1.92	2.26	2.94
70		.66	.77	.91	1.05	1.23	1.44	1.56	1.68	1.83	1.95	2.29	2.98

ASD TR 61-191(II)

III-102

TABLE III B-11
 LINEAR ROLL FORMING LIMITS
 HEEL-IN CHANNELS
 RENE'41 (SOLUTION TREATED)

Contour Radius R	Material Thickness (t)												
	.016	.020	.025	.032	.040	.050	.063	.071	.080	.090	.100	.125	.187
	Section Height Limits (h)												
5		.28	.35	.45	.56	.70	.86	.99					
10		.36	.42	.49	.56	.70	.86	.99	1.12	1.26	1.40	1.75	
15		.40	.47	.55	.64	.75	.86	.99	1.12	1.26	1.40	1.75	2.62
20		.44	.51	.61	.71	.83	.95	1.05	1.13	1.26	1.40	1.75	2.62
25		.48	.55	.65	.76	.89	1.04	1.13	1.21	1.34	1.42	1.75	2.62
30		.50	.59	.69	.80	.94	1.08	1.19	1.28	1.39	1.50	1.75	2.62
35		.54	.62	.74	.85	1.00	1.15	1.26	1.36	1.47	1.58	1.86	2.62
40		.57	.66	.78	.90	1.05	1.23	1.33	1.44	1.55	1.68	1.95	2.62
45		.58	.68	.80	.93	1.09	1.26	1.36	1.50	1.62	1.72	2.02	2.64
50		.60	.70	.83	.96	1.13	1.31	1.41	1.52	1.66	1.79	2.10	2.75
55		.62	.72	.86	1.00	1.15	1.34	1.45	1.57	1.71	1.82	2.15	2.80
60		.64	.74	.87	1.01	1.19	1.39	1.49	1.60	1.76	1.89	2.18	2.84
65		.65	.75	.89	1.04	1.26	1.40	1.52	1.66	1.80	1.93	2.25	2.96
70		.67	.78	.92	1.08	1.25	1.45	1.57	1.69	1.84	1.98	2.28	3.01

ASD TR 61-191(II)

III-103

TABLE III B-12
 LINEAR ROLL FORMING LIMITS
 HEEL-IN CHANNELS
 INCONEL X (C.R. ANNEALED)

Contour Radius R	Material Thickness (t)												
	.016	.020	.025	.032	.040	.050	.063	.071	.080	.090	.100	.125	.187
	Section Height Limits (h)												
5		.32	.40	.50	.63	.79	.99	1.12					
10		.36	.46	.54	.63	.79	.99	1.12	1.26	1.42	1.58	1.98	
15		.42	.52	.62	.72	.84	.99	1.12	1.26	1.42	1.58	1.98	2.96
20		.46	.58	.68	.80	.93	.99	1.16	1.28	1.42	1.58	1.98	2.96
25		.50	.62	.74	.85	1.00	1.15	1.27	1.37	1.48	1.60	1.98	2.96
30		.53	.66	.77	.91	1.05	1.22	1.34	1.44	1.56	1.69	1.98	2.96
35		.60	.70	.83	.96	1.10	1.31	1.42	1.52	1.65	1.79	2.10	2.96
40		.62	.73	.86	1.00	1.15	1.37	1.46	1.59	1.72	1.84	2.14	2.96
45		.64	.76	.89	1.04	1.22	1.43	1.52	1.67	1.80	1.96	2.26	2.96
50		.68	.78	.93	1.07	1.25	1.45	1.56	1.69	1.85	2.00	2.34	3.03
55		.69	.80	.95	1.10	1.28	1.51	1.63	1.76	1.91	2.06	2.40	3.16
60		.70	.82	.98	1.12	1.30	1.54	1.65	1.78	1.96	2.10	2.44	3.18
65		.72	.85	.99	1.16	1.35	1.57	1.70	1.85	2.00	2.18	2.50	3.29
70		.80	.86	1.02	1.18	1.37	1.60	1.74	1.88	2.06	2.20	2.65	3.38

ASD TR 61-191(II)

III-104

TABLE III B-13
 LINEAR ROLL FORMING LIMITS
 HEEL-IN CHANNELS
 HASTELLOY X (SOLUTION TREATED)

Contour Radius R	Material Thickness (t)												
	.016	.020	.025	.032	.040	.050	.063	.071	.080	.090	.100	.125	.187
	Section Height Limits (h)												
5		.29	.36	.46	.58	.72	.91	1.03					
10		.36	.42	.51	.58	.72	.91	1.03	1.16	1.30	1.45	1.81	
15		.42	.48	.57	.67	.74	.91	1.03	1.16	1.30	1.45	1.81	2.71
20		.46	.53	.63	.73	.85	1.00	1.08	1.18	1.30	1.45	1.81	2.71
25		.49	.57	.67	.80	.91	1.07	1.16	1.27	1.36	1.48	1.81	2.71
30		.52	.60	.71	.83	.95	1.13	1.21	1.33	1.44	1.54	1.81	2.71
35		.55	.64	.76	.88	1.02	1.20	1.30	1.41	1.52	1.62	1.90	2.71
40		.58	.67	.80	.92	1.05	1.25	1.35	1.45	1.60	1.72	1.99	2.71
45		.60	.70	.82	.95	1.00	1.29	1.41	1.52	1.64	1.78	2.07	2.71
50		.62	.72	.86	1.00	1.15	1.35	1.46	1.58	1.72	1.86	2.15	2.80
55		.63	.74	.88	1.03	1.19	1.39	1.50	1.62	1.78	1.90	2.23	2.90
60		.66	.75	.90	1.05	1.22	1.44	1.56	1.67	1.80	1.95	2.26	2.98
65		.68	.78	.93	1.08	1.25	1.50	1.58	1.72	1.87	2.00	2.35	3.03
70		.69	.80	.95	1.09	1.29	1.51	1.62	1.76	1.89	2.02	2.36	3.12

ASD TR 61-191(II)

III-105

TABLE III B-14
 LINEAR ROLL FORMING LIMITS
 HEEL-IN CHANNELS
 L-605 (SOLUTION TREATED)

Contour Radius R	Material Thickness (t)												
	.015	.020	.025	.032	.040	.050	.063	.071	.080	.090	.100	.125	.187
	Section Height Limits (h)												
5		.29	.36	.46	.58	.72	.91	1.03					
10		.36	.42	.51	.58	.72	.91	1.03	1.16	1.30	1.45	1.81	
15		.42	.48	.57	.67	.74	.91	1.03	1.16	1.30	1.45	1.81	2.71
20		.46	.53	.63	.73	.85	1.00	1.08	1.18	1.30	1.45	1.81	2.71
25		.49	.57	.67	.80	.91	1.07	1.16	1.27	1.36	1.48	1.81	2.71
30		.52	.60	.71	.83	.95	1.13	1.21	1.33	1.44	1.54	1.81	2.71
35		.55	.64	.76	.88	1.02	1.20	1.30	1.41	1.52	1.62	1.90	2.71
40		.58	.67	.80	.92	1.05	1.25	1.35	1.45	1.60	1.72	1.99	2.71
45		.60	.70	.82	.95	1.10	1.29	1.41	1.52	1.64	1.78	2.07	2.71
50		.62	.72	.86	1.00	1.15	1.35	1.46	1.58	1.72	1.86	2.15	2.80
55		.63	.74	.88	1.03	1.19	1.39	1.50	1.62	1.78	1.90	2.23	2.90
60		.66	.75	.90	1.05	1.22	1.44	1.56	1.67	1.80	1.95	2.26	2.98
65		.68	.78	.93	1.08	1.25	1.50	1.58	1.72	1.87	2.00	2.35	3.03
70		.69	.80	.95	1.09	1.29	1.51	1.62	1.76	1.89	2.02	2.36	3.12

ASD TR 61-191(II)

III-106

TABLE III B-15
 LINEAR ROLL FORMING LIMITS
 HEEL-IN CHANNELS
 J-1570 (SOLUTION TREATED)

Contour Radius R	Material Thickness (t)												
	.016	.020	.025	.032	.040	.050	.063	.071	.080	.090	.100	.125	.187
	Section Height Limits (h)												
5		.30	.37	.48	.60	.75	.95	1.07					
10		.38	.44	.52	.60	.75	.95	1.07	1.20	1.35	1.50	1.87	
15		.43	.50	.59	.68	.80	.95	1.07	1.20	1.35	1.50	1.87	2.80
20		.48	.55	.66	.76	.89	1.03	1.13	1.20	1.35	1.50	1.87	2.80
25		.50	.59	.70	.81	.94	1.10	1.20	1.29	1.40	1.50	1.87	2.80
30		.54	.62	.74	.86	1.00	1.17	1.28	1.37	1.49	1.60	1.87	2.80
35		.56	.65	.78	.90	1.05	1.23	1.34	1.45	1.55	1.69	1.96	2.80
40		.60	.69	.81	.94	1.10	1.28	1.38	1.50	1.63	1.75	2.04	2.80
45		.62	.71	.83	.98	1.15	1.32	1.43	1.57	1.70	1.81	2.12	2.80
50		.64	.75	.88	1.03	1.19	1.39	1.49	1.61	1.78	1.90	2.22	2.88
55		.66	.76	.90	1.04	1.21	1.44	1.56	1.68	1.82	1.95	2.28	2.99
60		.67	.78	.93	1.08	1.25	1.46	1.59	1.72	1.85	2.00	2.34	3.04
65		.70	.80	.96	1.11	1.29	1.51	1.63	1.76	1.91	2.03	2.39	3.16
70		.72	.82	.99	1.14	1.32	1.54	1.66	1.80	1.96	2.10	2.44	3.20

TABLE III B-16
 LINEAR ROLL FORMING LIMITS
 HEEL-IN CHANNELS
 COLUMBIUM (10Mo-10Ti)

Contour Radius R	Material Thickness (t)												
	.016	.020	.025	.032	.040	.050	.063	.071	.080	.090	.100	.125	.187
	Section Height Limits (h)												
5		.20	.24	.30	.38	.47	.60						
10		.25	.29	.33	.40	.47	.60	.67	.76	.85	.95	1.18	
15		.28	.33	.39	.45	.53	.62	.67	.76	.85	.95	1.18	1.78
20		.31	.36	.43	.45	.59	.68	.72	.80	.86	.95	1.18	1.78
25		.34	.39	.47	.54	.63	.74	.79	.86	.93	1.00	1.18	1.78
30		.36	.41	.48	.56	.66	.76	.84	.90	.97	1.03	1.22	1.78
35		.38	.44	.52	.60	.70	.81	.90	.96	1.04	1.11	1.29	1.78
40		.40	.45	.54	.63	.74	.86	.92	.98	1.08	1.17	1.35	1.78
45		.41	.47	.56	.65	.76	.88	.96	1.04	1.12	1.21	1.40	1.83
50		.42	.50	.58	.68	.79	.95	.99	1.06	1.17	1.26	1.46	1.91
55		.44	.50	.60	.70	.81	.95	1.03	1.12	1.21	1.29	1.51	1.96
60		.45	.52	.61	.72	.84	.96	1.05	1.13	1.27	1.33	1.53	2.02
65		.46	.53	.64	.74	.85	.99	1.06	1.18	1.27	1.36	1.60	2.08
70		.47	.55	.64	.75	.86	1.01	1.08	1.19	1.29	1.39	1.61	2.09

ASD TR 61-191(II)

III-108

TABLE III B-17
 LINEAR ROLL FORMING LIMITS
 HEEL-IN CHANNELS
 MOLYBDENUM (5% TI)

Contour Radius R	Material Thickness (t)												
	.015	.020	.025	.032	.040	.050	.063	.071	.080	.090	.100	.125	.187
	Section Height Limits (h)												
5		.28	.33	.43	.53	.66	.84	.94					
10		.34	.40	.47	.55	.66	.84	.94	1.06	1.20	1.33	1.66	
15		.39	.45	.54	.62	.72	.86	.94	1.06	1.20	1.33	1.66	2.49
20		.43	.50	.63	.69	.80	.94	1.02	1.10	1.20	1.33	1.66	2.49
25		.47	.54	.64	.74	.86	1.01	1.09	1.19	1.29	1.40	1.66	2.49
30		.49	.57	.67	.78	.90	1.07	1.15	1.25	1.35	1.45	1.69	2.49
35		.52	.60	.71	.83	.96	1.13	1.22	1.33	1.42	1.53	1.80	2.49
40		.54	.63	.74	.87	1.00	1.18	1.28	1.37	1.49	1.60	1.87	2.49
45		.57	.66	.77	.90	1.05	1.22	1.33	1.44	1.56	1.68	1.92	2.54
50		.58	.68	.81	.94	1.09	1.26	1.36	1.48	1.60	1.72	2.00	2.62
55		.60	.70	.83	.96	1.11	1.31	1.42	1.53	1.68	1.78	2.09	2.73
60		.62	.72	.85	.99	1.15	1.35	1.45	1.58	1.71	1.83	2.12	2.80
65		.64	.74	.87	1.02	1.18	1.37	1.49	1.62	1.76	1.88	2.18	2.88
70		.65	.75	.90	1.04	1.20	1.41	1.52	1.65	1.80	1.92	2.23	2.96

ASD TR 61-191(II)

III-109

TABLE III B-18
 LINEAR ROLL FORMING LIMITS
 HEEL-OUT CHANNELS
 HM21XA-T8 (MAGNESIUM THORIUM)

Contour Radius R	Material Thickness (t)												
	.016	.020	.025	.032	.040	.050	.063	.071	.080	.090	.100	.125	.187
	Section Height Limits (h)												
5		.24	.27	.32	.40	.50							
10		.30	.35	.41	.48	.54	.64	.72	.81	.91	1.01		
15		.34	.40	.47	.55	.63	.74	.79	.86	.92	1.01	1.26	
20		.38	.44	.52	.60	.70	.81	.88	.94	1.03	1.10	1.26	1.89
25		.40	.47	.56	.64	.74	.88	.94	1.01	1.11	1.18	1.37	1.89
30		.44	.50	.59	.68	.79	.94	.99	1.09	1.17	1.27	1.44	1.89
35		.46	.53	.62	.72	.84	.97	1.06	1.14	1.24	1.32	1.53	1.98
40		.48	.55	.65	.76	.88	1.02	1.11	1.20	1.31	1.39	1.62	2.07
45		.50	.57	.67	.78	.90	1.06	1.13	1.24	1.35	1.44	1.66	2.17
50		.52	.60	.70	.81	.94	1.09	1.18	1.28	1.39	1.50	1.72	2.24
55		.54	.62	.72	.84	.97	1.13	1.23	1.33	1.44	1.54	1.79	2.31
60		.55	.64	.74	.87	1.00	1.18	1.28	1.36	1.48	1.60	1.85	2.43
65		.56	.66	.77	.89	1.04	1.20	1.30	1.41	1.53	1.64	1.90	2.50
70		.58	.68	.80	.91	1.05	1.27	1.33	1.45	1.57	1.68	1.95	2.56

ASD TR 61-191(II)

III-110

TABLE III B-19
 LINEAR ROLL FORMING LIMITS
 HEEL-OUT CHANNELS
 2024-0 ALUMINUM

ASD TR 61-191(II)

III-111

Contour Radius R	Material Thickness (t)												
	.016	.020	.025	.032	.040	.050	.063	.071	.080	.090	.100	.125	.187
	Section Height Limits (h)												
5		.31	.36	.45	.56	.70							
10		.40	.45	.54	.62	.71	.88	.99	1.12	1.26	1.40		
15		.46	.52	.61	.72	.82	.96	1.05	1.12	1.26	1.40	1.75	
20		.50	.58	.68	.76	.92	1.07	1.16	1.24	1.30	1.44	1.75	2.62
25		.54	.62	.74	.84	.98	1.13	1.24	1.35	1.35	1.53	1.75	2.62
30		.57	.66	.77	.90	1.04	1.20	1.31	1.43	1.40	1.67	1.89	2.62
35		.60	.70	.82	.95	1.10	1.27	1.38	1.51	1.54	1.73	2.00	2.62
40		.64	.73	.86	1.00	1.15	1.34	1.44	1.58	1.62	1.81	2.11	2.62
45		.65	.75	.89	1.03	1.20	1.39	1.49	1.61	1.71	1.90	2.20	2.77
50		.68	.78	.92	1.07	1.25	1.45	1.56	1.68	1.79	1.97	2.26	2.84
55		.70	.80	.94	1.11	1.29	1.51	1.63	1.76	1.85	2.01	2.35	3.01
60		.72	.83	.96	1.14	1.32	1.55	1.67	1.80	1.89	2.06	2.44	3.18
65		.74	.85	1.00	1.16	1.35	1.57	1.71	1.84	1.99	2.12	2.47	3.28
70		.76	.88	1.05	1.20	1.39	1.63	1.77	1.91	2.07	2.20	2.56	3.35

TABLE III B-20
 LINEAR ROLL FORMING LIMITS
 HEEL-OUT CHANNELS
 17-7 PH (Condition A)

Contour Radius R	Material Thickness (t)												
	.016	.020	.025	.032	.040	.050	.063	.071	.080	.090	.100	.125	.187
	Section Height Limits (h)												
5		.29	.34	.42	.52	.65							
10		.37	.43	.50	.58	.67	.82	.91	1.04	1.17	1.30		
15		.42	.50	.58	.67	.77	.91	.98	1.05	1.17	1.30	1.62	
20		.47	.55	.64	.75	.87	1.00	1.09	1.18	1.26	1.36	1.62	2.43
25		.51	.59	.69	.80	.93	1.03	1.17	1.26	1.37	1.48	1.69	2.43
30		.54	.62	.74	.84	.98	1.14	1.23	1.34	1.45	1.56	1.77	2.43
35		.56	.65	.77	.89	1.04	1.20	1.31	1.41	1.53	1.65	1.89	2.43
40		.60	.71	.81	.94	1.10	1.27	1.36	1.47	1.60	1.71	1.99	2.58
45		.61	.71	.83	.96	1.13	1.32	1.42	1.54	1.67	1.79	2.06	2.71
50		.64	.74	.86	1.00	1.16	1.35	1.47	1.59	1.71	1.85	2.14	2.78
55		.66	.76	.90	1.05	1.20	1.39	1.50	1.64	1.79	1.90	2.20	2.84
60		.68	.79	.93	1.08	1.25	1.46	1.57	1.69	1.83	1.98	2.27	2.98
65		.70	.80	.95	1.10	1.33	1.49	1.61	1.75	1.88	2.01	2.35	3.05
70		.71	.82	.97	1.12	1.31	1.52	1.64	1.78	1.92	2.05	2.41	3.14

ASD TR 61-191(II)

III-112

TABLE III B-21
 LINEAR ROLL FORMING LIMITS
 HEEL-OUT CHANNELS
 PH 15-7 Mo (Condition A)

Contour Radius R	Material Thickness (t)												
	.015	.020	.025	.032	.040	.050	.063	.071	.080	.090	.100	.125	.187
	Section Height Limits (h)												
5		.31	.36	.45	.56	.71							
10		.39	.45	.54	.62	.71	.88	.99	1.12	1.26	1.40		
15		.45	.52	.61	.71	.82	.96	1.05	1.12	1.26	1.40	1.75	
20		.50	.58	.68	.80	.91	1.06	1.15	1.24	1.35	1.44	1.75	2.62
25		.54	.62	.74	.84	.99	1.14	1.24	1.35	1.45	1.55	1.79	2.62
30		.57	.66	.77	.90	1.04	1.20	1.31	1.44	1.55	1.67	1.89	2.62
35		.60	.70	.82	.94	1.10	1.27	1.38	1.50	1.62	1.74	2.01	2.62
40		.62	.72	.86	1.00	1.15	1.34	1.44	1.58	1.70	1.81	2.11	2.77
45		.64	.75	.88	1.03	1.19	1.39	1.49	1.63	1.79	1.89	2.19	2.82
50		.68	.77	.92	1.06	1.24	1.44	1.56	1.68	1.84	1.96	2.26	2.95
55		.70	.81	.94	1.11	1.28	1.49	1.63	1.75	1.89	2.01	2.35	3.01
60		.72	.83	.96	1.14	1.32	1.54	1.67	1.80	1.96	2.10	2.44	3.18
65		.74	.85	1.00	1.17	1.35	1.57	1.70	1.84	2.00	2.14	2.49	3.27
70		.76	.87	1.04	1.20	1.40	1.63	1.77	1.91	2.07	2.20	2.57	3.36

ASD TR 61-191(II)

III-113

TABLE III B-22
 LINEAR ROLL FORMING LIMITS
 HEEL-OUT CHANNELS
 AM-350 (Annealed)

Contour Radius R	Material Thickness (t)												
	.016	.020	.025	.032	.040	.050	.063	.071	.080	.090	.100	.125	.187
	Section Height Limits (h)												
5		.28	.32	.40	.50	.62							
10		.36	.41	.48	.56	.64	.79	.89	1.00	1.12	1.25		
15		.41	.47	.56	.64	.74	.87	.94	1.02	1.12	1.25	1.56	
20		.45	.52	.61	.72	.83	.96	1.05	1.13	1.22	1.30	1.56	2.33
25		.48	.56	.66	.76	.89	1.03	1.13	1.20	1.32	1.40	1.62	2.33
30		.52	.60	.70	.81	.94	1.10	1.19	1.79	1.40	1.50	1.72	2.33
35		.54	.63	.74	.85	.99	1.15	1.26	1.35	1.46	1.58	1.82	2.37
40		.56	.66	.77	.90	1.04	1.21	1.31	1.42	1.53	1.64	1.90	2.48
45		.58	.68	.80	.92	1.07	1.26	1.36	1.47	1.60	1.71	2.00	2.58
50		.60	.70	.83	.96	1.11	1.29	1.41	1.52	1.64	1.78	2.05	2.67
55		.63	.73	.86	1.00	1.15	1.34	1.46	1.58	1.71	1.82	2.12	2.75
60		.64	.75	.88	1.03	1.19	1.39	1.50	1.61	1.78	1.90	2.20	2.86
65		.66	.76	.90	1.05	1.21	1.42	1.53	1.67	1.80	1.92	2.24	2.97
70		.68	.77	.93	1.08	1.25	1.46	1.57	1.71	1.85	1.98	2.31	3.03

ASD TR 61-191(II)

III-114

TABLE III B-23
 LINERAR ROLL FORMING LIMITS
 HEEL-OUT CHANNELS
 A-286 (Solution treated)

Contour Radius R	Material Thickness (t)												
	.016	.020	.025	.032	.040	.050	.063	.071	.080	.090	.100	.125	.187
	Section Height Limits (h)												
5		.32	.38	.48	.60	.75							
10		.42	.48	.57	.65	.75	.94	1.07	1.20	1.35	1.50		
15		.48	.55	.65	.76	.86	1.01	1.12	1.20	1.35	1.50	1.87	
20		.53	.61	.72	.84	.97	1.13	1.21	1.32	1.44	1.52	1.87	2.80
25		.56	.65	.77	.89	1.04	1.20	1.31	1.43	1.53	1.64	1.89	2.80
30		.60	.70	.82	.95	1.10	1.27	1.41	1.51	1.63	1.75	2.00	2.80
35		.62	.73	.86	1.00	1.15	1.34	1.46	1.59	1.71	1.83	2.12	2.80
40		.66	.76	.90	1.04	1.30	1.44	1.55	1.67	1.80	1.91	2.24	2.93
45		.70	.79	.93	1.08	1.35	1.49	1.59	1.75	1.89	2.00	2.33	3.03
50		.72	.82	.96	1.12	1.40	1.52	1.64	1.80	1.96	2.09	2.40	3.15
55		.74	.85	1.00	1.16	1.45	1.57	1.70	1.84	2.00	2.13	2.50	3.27
60		.76	.87	1.02	1.20	1.50	1.64	1.77	1.91	2.07	2.21	2.56	3.36
65		.78	.90	1.07	1.24	1.55	1.69	1.82	1.97	2.12	2.29	2.62	3.48
70		.80	.92	1.09	1.26	1.57	1.71	1.85	2.00	2.16	2.31	2.74	3.55

ASD TR 61-191(II)

III-115

TABLE III B-24
 LINEAR ROLL FORMING LIMITS
 HEEL-OUT CHANNELS
 USS-12-MoV (Annealed)

Contour Radius R	Material Thickness (t)												
	.016	.020	.025	.032	.040	.050	.063	.071	.080	.090	.100	.125	.187
	Section Height Limits (h)												
5		.28	.32	.39	.49	.62							
10		.36	.42	.48	.56	.65	.76	.87	.98	1.11	1.23		
15		.41	.47	.56	.64	.75	.88	.95	1.01	1.11	1.23	1.54	
20		.45	.52	.61	.72	.83	.95	1.05	1.12	1.21	1.30	1.54	2.30
25		.48	.56	.66	.76	.89	1.03	1.12	1.20	1.31	1.40	1.63	2.30
30		.52	.60	.70	.81	.94	1.10	1.19	1.28	1.40	1.50	1.73	2.30
35		.54	.63	.74	.85	.99	1.15	1.26	1.35	1.46	1.58	1.83	2.34
40		.57	.66	.77	.90	1.05	1.22	1.32	1.42	1.56	1.65	1.90	2.47
45		.59	.68	.80	.93	1.08	1.27	1.35	1.48	1.61	1.71	1.99	2.60
50		.61	.70	.83	.94	1.11	1.29	1.41	1.52	1.64	1.78	2.05	2.68
55		.64	.73	.86	.96	1.16	1.34	1.45	1.58	1.71	1.82	2.13	2.75
60		.65	.75	.89	1.00	1.20	1.39	1.50	1.61	1.79	1.90	2.16	2.84
65		.67	.77	.91	1.06	1.24	1.44	1.56	1.68	1.80	1.94	2.25	2.96
70		.69	.80	.94	1.08	1.26	1.46	1.58	1.70	1.86	2.00	2.31	3.03

ASD TR 61-191(II)

III-116

TABLE III B-25
 LINEAR ROLL FORMING LIMITS
 HEEL-OUT CHANNELS
 Titanium (6Al-4V)(Mill Annealed)

Contour Radius R	Material Thickness (t)												
	.016	.020	.025	.032	.040	.050	.063	.071	.080	.090	.100	.125	.187
	Section Height Limits (h)												
5		.17	.18	.22	.28								
10		.22	.25	.30	.35	.40	.47	.51	.58	.63	.70		
15		.25	.29	.35	.40	.46	.54	.59	.67	.68	.74	.87	
20		.28	.32	.38	.44	.51	.60	.65	.73	.76	.81	.94	1.31
25		.30	.35	.42	.48	.55	.63	.70	.78	.82	.87	1.01	1.31
30		.32	.37	.44	.50	.58	.68	.74	.83	.86	.93	1.06	1.40
35		.34	.39	.46	.53	.61	.71	.78	.86	.91	.98	1.13	1.43
40		.35	.40	.48	.56	.65	.76	.82	.88	.97	1.02	1.19	1.55
45		.36	.42	.50	.58	.67	.79	.85	.92	.99	1.07	1.24	1.63
50		.38	.44	.51	.60	.70	.81	.87	.95	1.03	1.10	1.27	1.68
55		.39	.45	.53	.62	.72	.83	.91	.98	1.06	1.13	1.31	1.72
60		.40	.46	.54	.64	.75	.86	.93	1.02	1.09	1.18	1.37	1.78
65		.41	.48	.57	.66	.76	.88	.96	1.04	1.13	1.20	1.40	1.83
70		.42	.49	.58	.68	.77	.91	.99	1.06	1.16	1.23	1.44	1.87

ASD TR 61-191(II)

III-117

TABLE III B-26
 LINEAR ROLL FORMING LIMITS
 HEEL-OUT CHANNELS
 Titanium (13V-11 Cr-3 Al)(Solution treated)

Contour Radius R	Material Thickness (t)												
	.016	.020	.025	.032	.040	.050	.063	.071	.080	.090	.100	.125	.187
	Section Height Limits (h)												
5		.17	.19	.24	.27	.32							
10		.21	.25	.29	.34	.39	.45	.50	.54	.60	.67		
15		.24	.28	.33	.38	.44	.52	.57	.61	.66	.71	.84	
20		.27	.31	.37	.43	.49	.57	.62	.67	.73	.78	.90	1.25
25		.29	.33	.39	.45	.53	.62	.67	.72	.79	.85	.97	1.27
30		.30	.35	.42	.48	.55	.66	.71	.77	.84	.89	1.02	1.34
35		.32	.37	.44	.51	.59	.69	.74	.81	.87	.94	1.09	1.40
40		.34	.39	.46	.53	.61	.72	.78	.85	.92	.99	1.14	1.49
45		.35	.40	.48	.55	.64	.75	.81	.88	.95	1.03	1.19	1.59
50		.36	.42	.49	.56	.66	.77	.84	.90	.98	1.06	1.22	1.63
55		.37	.43	.51	.59	.69	.80	.87	.94	1.01	1.09	1.26	1.66
60		.38	.44	.52	.61	.70	.82	.89	.96	1.05	1.13	1.31	1.72
65		.39	.45	.54	.62	.72	.84	.92	.99	1.08	1.16	1.34	1.77
70		.40	.47	.55	.64	.75	.88	.94	1.02	1.10	1.18	1.37	1.81

ASD TR 61-191 (II)

III-118

TABLE III B-27
 LINEAR ROLL FORMING LIMITS
 HEEL-CUT CHANNELS
 Vascojet 1000 (H-11)(Annealed)

Contour Radius R	Material Thickness (t)												
	.016	.020	.025	.032	.040	.050	.063	.071	.080	.090	.100	.125	.187
	Section Height Limits (h)												
5		.26	.30	.35	.44	.50							
10		.32	.37	.44	.51	.59	.70	.79	.89	1.00	1.11		
15		.38	.43	.51	.59	.69	.80	.86	.94	1.00	1.11	1.39	
20		.41	.48	.57	.66	.75	.88	.96	1.04	1.16	1.24	1.44	2.08
25		.44	.51	.60	.70	.80	.94	1.05	1.11	1.21	1.29	1.50	2.08
30		.47	.55	.64	.74	.85	1.01	1.07	1.19	1.27	1.38	1.56	2.08
35		.50	.58	.67	.78	.90	1.06	1.14	1.23	1.34	1.44	1.65	2.15
40		.52	.60	.70	.82	.95	1.11	1.20	1.29	1.39	1.50	1.75	2.26
45		.54	.62	.74	.85	.99	1.15	1.24	1.36	1.48	1.58	1.82	2.39
50		.56	.65	.75	.88	1.02	1.19	1.28	1.39	1.52	1.61	1.87	2.46
55		.58	.67	.78	.92	1.05	1.23	1.34	1.44	1.56	1.68	1.94	2.52
60		.60	.69	.80	.94	1.09	1.27	1.36	1.50	1.62	1.72	2.00	2.62
65		.61	.71	.83	.96	1.12	1.31	1.41	1.53	1.66	1.78	2.04	2.69
70		.63	.73	.86	1.00	1.15	1.33	1.43	1.58	1.70	1.81	2.12	2.76

ASD TR 61-191(II)

III-119

TABLE III B-28
 LINEAR ROLL FORMING LIMITS
 HEEL-OUT CHANNELS
 René 41 (Solution Treated)

Contour Radius R	Material Thickness (t)												
	.016	.020	.025	.032	.040	.050	.063	.071	.080	.090	.100	.125	.187
	Section Height Limits (h)												
5		.28	.33	.41	.52	.64							
10		.36	.42	.49	.56	.65	.81	.92	1.03	1.16	1.29		
15		.41	.48	.57	.65	.75	.88	.96	1.04	1.16	1.29	1.61	
20		.46	.52	.62	.72	.84	.96	1.07	1.13	1.24	1.32	1.61	2.41
25		.49	.57	.67	.77	.90	1.06	1.14	1.21	1.34	1.42	1.64	2.41
30		.52	.60	.71	.82	.95	1.12	1.21	1.31	1.41	1.52	1.74	2.41
35		.54	.63	.74	.87	1.00	1.16	1.27	1.36	1.48	1.60	1.85	2.41
40		.57	.66	.78	.91	1.05	1.23	1.34	1.44	1.54	1.67	1.94	2.52
45		.60	.69	.80	.94	1.09	1.26	1.36	1.50	1.62	1.72	2.00	2.62
50		.62	.72	.83	.97	1.14	1.32	1.42	1.54	1.69	1.80	2.11	2.71
55		.64	.74	.87	1.00	1.16	1.36	1.48	1.60	1.72	1.86	2.17	2.80
60		.66	.75	.89	1.04	1.20	1.40	1.51	1.64	1.79	1.91	2.24	2.88
65		.67	.77	.92	1.07	1.24	1.45	1.56	1.68	1.81	1.95	2.30	3.00
70		.68	.80	.94	1.09	1.27	1.48	1.60	1.73	1.87	2.00	2.36	3.03

ASD TR 61-191(II)

III-120

TABLE III B-29
 LINEAR ROLL FORMING LIMITS
 HEEL-OUT CHANNELS
 INCONEL X (C.R. ANNEALED)

Contour Radius R	Material Thickness (t)												
	.015	.020	.025	.032	.040	.050	.063	.071	.080	.090	.100	.125	.187
	Section Height Limits (h)												
5		.29	.34	.42	.52	.65	---	---	---	---	---	---	---
10		.37	.43	.50	.58	.67	.82	.91	1.04	1.17	1.30	---	---
15		.42	.50	.58	.67	.77	.91	.98	1.05	1.17	1.30	1.62	---
20		.47	.55	.64	.75	.87	1.00	1.09	1.18	1.26	1.36	1.62	2.43
25		.51	.59	.69	.80	.93	1.08	1.17	1.26	1.37	1.48	1.69	2.43
30		.54	.62	.74	.84	.98	1.14	1.23	1.34	1.45	1.56	1.77	2.43
35		.56	.65	.77	.89	1.04	1.20	1.31	1.41	1.53	1.65	1.89	2.43
40		.60	.71	.81	.94	1.10	1.27	1.36	1.47	1.60	1.71	1.99	2.58
45		.61	.71	.83	.96	1.13	1.32	1.42	1.54	1.67	1.79	2.06	2.71
50		.64	.74	.86	1.00	1.16	1.35	1.47	1.59	1.71	1.85	2.14	2.78
55		.66	.76	.90	1.05	1.20	1.39	1.50	1.64	1.79	1.90	2.20	2.84
60		.68	.79	.93	1.08	1.25	1.46	1.57	1.69	1.83	1.98	2.27	2.98
65		.70	.80	.95	1.10	1.33	1.49	1.61	1.75	1.88	2.01	2.35	3.05
70		.71	.82	.97	1.12	1.31	1.52	1.64	1.78	1.92	2.05	2.41	3.14

TABLE III B-30
 LINEAR ROLL FORMING LIMITS
 HEEL-OUT CHANNELS
 HASTELLOY X (SOLUTION TREATED)

Contour Radius R	Material Thickness (t)												
	.015	.020	.025	.032	.040	.050	.063	.071	.080	.090	.100	.125	.187
	Section Height Limits (h)												
5		.30	.35	.43	.54	.68	---	---	---	---	---	---	---
10		.38	.44	.51	.60	.69	.86	.96	1.09	1.22	1.36	---	---
15		.44	.50	.60	.69	.80	.94	1.01	1.10	1.22	1.36	1.70	---
20		.48	.55	.65	.76	.89	1.02	1.12	1.20	1.31	1.40	1.70	2.55
25		.54	.60	.71	.81	.95	1.11	1.21	1.29	1.41	1.50	1.75	2.55
30		.56	.63	.75	.87	1.00	1.17	1.28	1.37	1.50	1.60	1.96	2.55
35		.58	.67	.79	.92	1.05	1.24	1.34	1.44	1.57	1.69	2.00	2.56
40		.60	.70	.83	.96	1.10	1.29	1.40	1.52	1.63	1.75	2.04	2.63
45		.62	.73	.86	1.00	1.15	1.34	1.44	1.58	1.72	1.83	2.12	2.78
50		.64	.75	.88	1.02	1.19	1.39	.49	1.61	1.77	1.90	2.20	2.86
55		.67	.77	.91	1.06	1.23	1.44	1.56	1.68	1.82	1.95	2.26	2.93
60		.69	.80	.94	1.10	1.27	1.49	1.62	1.75	1.89	2.01	2.36	3.06
65		.71	.82	.96	1.12	1.30	1.51	1.64	1.77	1.91	2.06	2.42	3.16
70		.72	.84	.99	1.16	1.34	1.57	1.70	1.84	1.98	2.10	2.49	3.20

ASD TR 61-191(II)

III-122

TABLE III B-31
 LINEAR ROLL FORMING LIMITS
 HEEL-OUT CHANNELS
 L-605 (SOLUTION TREATED)

Contour Radius R	Material Thickness (t)												
	.016	.020	.025	.032	.040	.050	.063	.071	.080	.090	.100	.125	.187
	Section Height Limits (h)												
5		.31	.36	.45	.56	.71	---	---	---	---	---	---	---
10		.39	.45	.54	.62	.71	.88	.99	1.12	1.26	1.40	---	---
15		.45	.52	.61	.71	.82	.96	1.05	1.12	1.26	1.40	1.75	---
20		.50	.58	.68	.80	.91	1.06	1.15	1.24	1.35	1.44	1.75	2.62
25		.54	.62	.74	.84	.99	1.14	1.24	1.35	1.45	1.55	1.79	2.62
30		.57	.66	.77	.90	1.04	1.20	1.31	1.44	1.55	1.67	1.89	2.62
35		.60	.70	.82	.94	1.10	1.27	1.38	1.50	1.62	1.74	2.01	2.62
40		.62	.72	.86	1.00	1.15	1.34	1.44	1.58	1.70	1.81	2.11	2.77
45		.64	.75	.88	1.03	1.19	1.39	1.49	1.63	1.79	1.89	2.19	2.82
50		.68	.77	.92	1.06	1.24	1.44	1.56	1.68	1.84	1.96	2.26	2.95
55		.70	.81	.94	1.11	1.28	1.49	1.63	1.75	1.89	2.01	2.35	3.01
60		.72	.83	.96	1.14	1.32	1.54	1.67	1.80	1.96	2.10	2.44	3.18
65		.74	.85	1.00	1.17	1.35	1.57	1.70	1.84	2.00	2.14	2.49	3.27
70		.76	.87	1.04	1.20	1.40	1.63	1.77	1.91	2.07	2.20	2.57	3.36

TABLE III B-32
 LINEAR ROLL FORMING LIMITS
 HEEL-OUT CHANNELS
 J-1570 (SOLUTION TREATED)

Contour Radius R	Material Thickness (t)												
	.015	.020	.025	.032	.040	.050	.063	.071	.080	.090	.100	.125	.187
	Section Height Limits (h)												
5		.30	.34	.42	.53	.66	---	---	---	---	---	---	---
10		.34	.40	.47	.54	.66	.83	.94	1.05	1.19	1.32	---	---
15		.43	.50	.58	.68	.78	.92	.99	1.07	1.19	1.32	1.65	---
20		.47	.55	.64	.75	.87	1.01	1.10	1.18	1.27	1.37	1.65	2.47
25		.50	.59	.70	.80	.93	1.08	1.18	1.27	1.38	1.48	1.71	2.47
30		.54	.62	.74	.84	.99	1.14	1.24	1.36	1.46	1.58	1.80	2.47
35		.56	.65	.77	.90	1.04	1.20	1.31	1.43	1.53	1.65	1.92	2.47
40		.60	.69	.81	.94	1.10	1.27	1.38	1.49	1.62	1.72	2.00	2.62
45		.62	.71	.83	.96	1.13	1.32	1.42	1.54	1.68	1.80	2.08	2.72
50		.65	.73	.86	1.00	1.15	1.35	1.47	1.59	1.72	1.85	2.14	2.80
55		.66	.75	.89	1.04	1.20	1.39	1.52	1.64	1.78	1.90	2.23	2.88
60		.68	.77	.92	1.08	1.25	1.45	1.57	1.69	1.83	1.95	2.29	3.00
65		.69	.80	.94	1.10	1.27	1.49	1.61	1.74	1.88	2.01	2.36	3.08
70		.71	.82	.97	1.12	1.30	1.52	1.65	1.79	1.95	2.08	2.42	3.18

TABLE III B-33
 LINEAR ROLL FORMING LIMITS
 HEEL-OUT CHANNELS
 COLUMBIUM (10 Mo - 10 Ti)

Contour Radius R	Material Thickness (t)												
	.016	.020	.025	.032	.040	.050	.063	.071	.080	.090	.100	.125	.187
	Section Height Limits (h)												
5		.18	.22	.26	.32	.39	---	---	---	---	---	---	---
10		.24	.28	.32	.38	.44	.51	.55	.62	.70	.78	---	---
15		.27	.32	.38	.44	.50	.59	.64	.69	.75	.80	.97	---
20		.30	.35	.42	.48	.56	.64	.71	.76	.82	.88	1.03	1.46
25		.32	.37	.44	.52	.60	.69	.75	.81	.89	.95	1.10	1.46
30		.34	.40	.47	.55	.64	.74	.79	.87	.93	1.00	1.16	1.51
35		.36	.42	.49	.57	.66	.78	.85	.90	.99	1.06	1.20	1.59
40		.38	.44	.51	.60	.70	.82	.89	.96	1.04	1.11	1.27	1.68
45		.40	.45	.54	.62	.72	.84	.92	.99	1.08	1.15	1.35	1.76
50		.41	.47	.56	.64	.75	.87	.94	1.03	1.11	1.20	1.38	1.79
55		.42	.49	.58	.66	.77	.89	.99	1.05	1.16	1.21	1.40	1.85
60		.43	.50	.59	.68	.80	.94	1.00	1.10	1.18	1.28	1.46	1.91
65		.44	.52	.61	.71	.82	.95	1.04	1.13	1.22	1.30	1.50	.98
70		.46	.53	.62	.72	.84	.98	1.07	1.15	1.25	1.33	1.56	2.04

TABLE III B-34
 LINEAR ROLL FORMING LIMITS
 HEEL-OUT CHANNELS
 MOLYBDENUM (5% TI)

Contour Radius R	Material Thickness (t)												
	.015	.020	.025	.032	.040	.050	.063	.071	.080	.090	.100	.125	.187
	Section Height Limits (h)												
5		.25	.29	.35	.43	.54							
10		.32	.37	.43	.50	.58	.68	.77	.86	.97	1.08		
15		.36	.42	.50	.58	.66	.78	.85	.91	.97	1.08	1.35	
20		.40	.47	.55	.64	.75	.86	.94	1.01	1.10	1.18	1.35	2.02
25		.43	.50	.59	.68	.80	.93	1.00	1.08	1.18	1.26	1.45	2.02
30		.46	.53	.63	.72	.84	.99	1.06	1.15	1.25	1.34	1.54	2.02
35		.48	.56	.66	.76	.89	1.03	1.12	1.21	1.31	1.40	1.62	2.11
40		.51	.59	.69	.80	.94	1.08	1.18	1.27	1.37	1.47	1.71	2.22
45		.53	.61	.72	.84	.97	1.13	1.21	1.32	1.44	1.53	1.77	2.34
50		.55	.63	.74	.86	1.00	1.17	1.26	1.36	1.49	1.59	1.85	2.40
55		.55	.65	.77	.89	1.03	1.20	1.30	1.42	1.53	1.63	1.89	2.47
60		.58	.67	.79	.92	1.07	1.25	1.35	1.46	1.57	1.70	1.97	2.58
65		.60	.69	.82	.94	1.10	1.28	1.38	1.50	1.62	1.73	2.00	2.66
70		.61	.71	.84	.97	1.13	1.31	1.42	1.54	1.66	1.78	2.07	2.71

ASD TR 61-191(II)

III-126

SECTION IV
PLANE CONTOURING OF SHEET
A. SHEET STRETCH FORMING
B. ANDROFORMING

SHEET STRETCH

Description of Process

The sheet stretch process is the contouring of a sheet of metal by stretching over a die in such a manner that permanent set takes place, thus holding springback to a minimum. The forming of difficult shapes in one operation makes this a valuable process. Although a Sheridan 300 ton Stretch Press and workpiece specimens measuring 24 x 40 inches were used in this program the resultant data is applicable to any standard stretch press and any size material.

By referring to Figure IV A-1 the set-up for a sheet stretch operation is apparent.

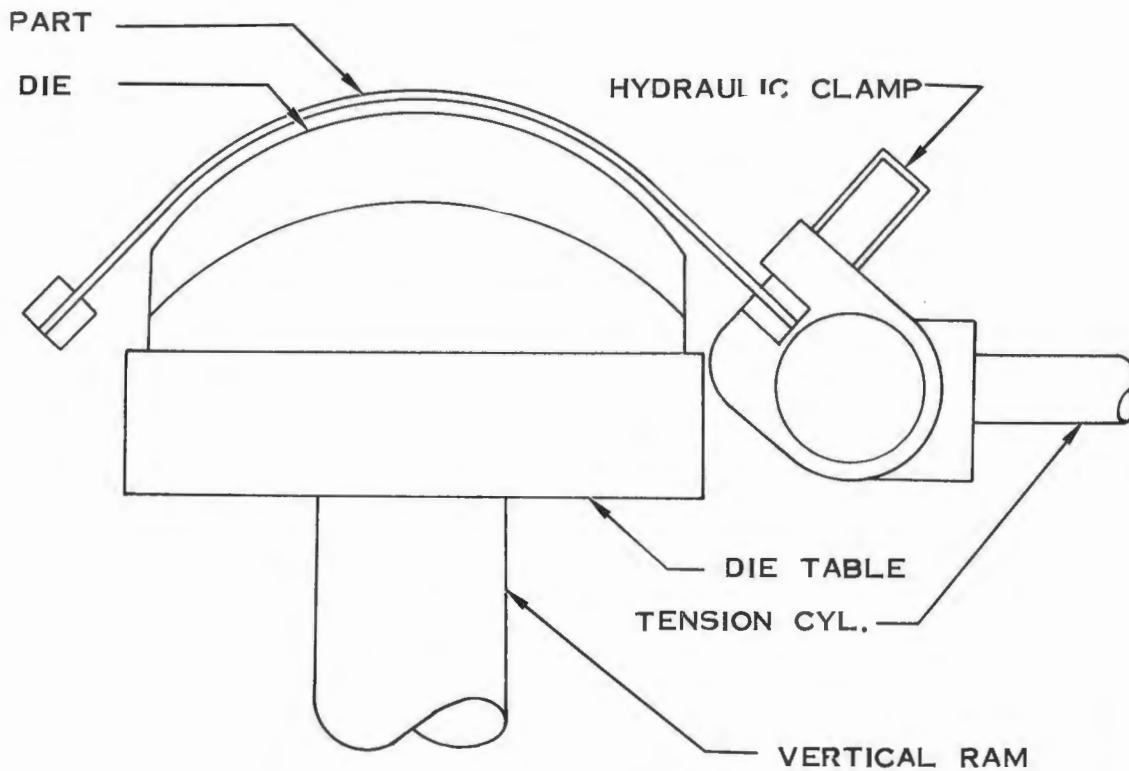

TYPICAL SHEET STRETCH SET-UP
FIGURE IVA-1

The ram raises the die into the workpiece while the jaws of the stretch press hold the workpiece securely. The force exerted by the ram forces the sheet metal to contour to the shape of the die.

To achieve the best results a proper set-up is a necessity. The die table should be perfectly level and the jaws of the machine should be as tangential as possible to the curvature of the die. The stretch press must be of sufficient tonnage as any increase in either material thickness or tensile strength will require an increase in pressure to stretch the material. The dies must be able to withstand the great pressures exerted on them or failure of the die will occur. Therefore, all hollow dies must have internal strengthening members.

There is an excess of material in any sheet stretch operation. This excess is the material that lies outside the formed area. This excess must be trimmed off and the workpiece cut to size for a finished part.

Definition of Part Shape and Geometric Variables

The geometric variables concerned with sheet stretch operations are the radii of the two curvatures and their respective chord lengths. The radius over which the sheet is pulled is designated as (R_T) with its respective chord length being designated (T). The other radius is designated as (R_L) with its chord length being (L). (See Figure IV A-2)

GEOMETRIC VARIABLES OF SHEET STRETCH
 FIGURE IV A-2

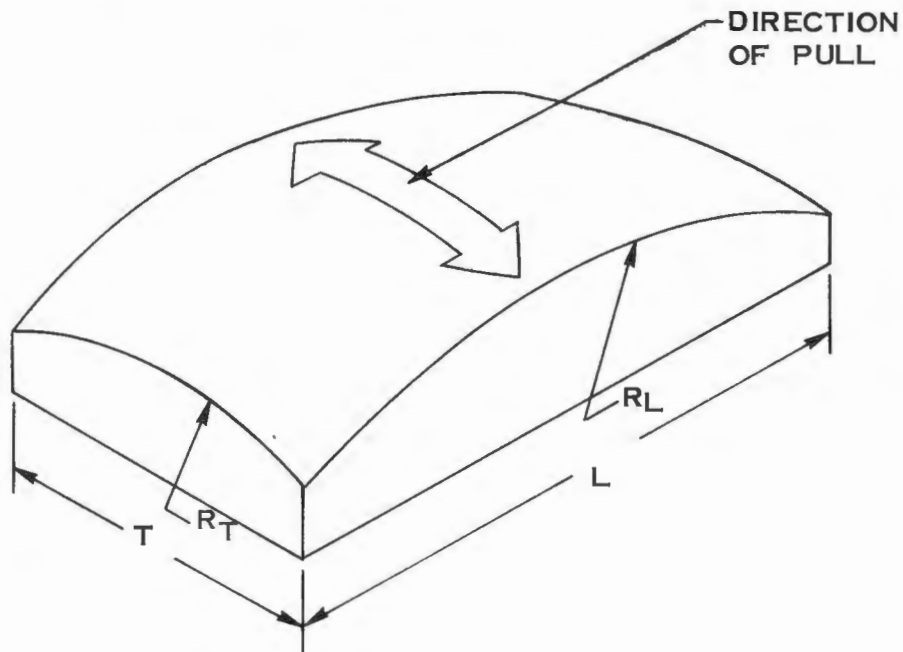

The direction of pull in a sheet stretch operation is determined by the smaller radii on the die. The work sheet is always stretched over the smallest radius. The work sheet should also be pulled parallel to the direction of rolling. In this way the "grain" of the metal will be parallel to the severest radius rather than perpendicular to it. The direction of rolling has an appreciable effect on the forming limits and should always be considered in a stretching operation. (See Figure IV A-3).

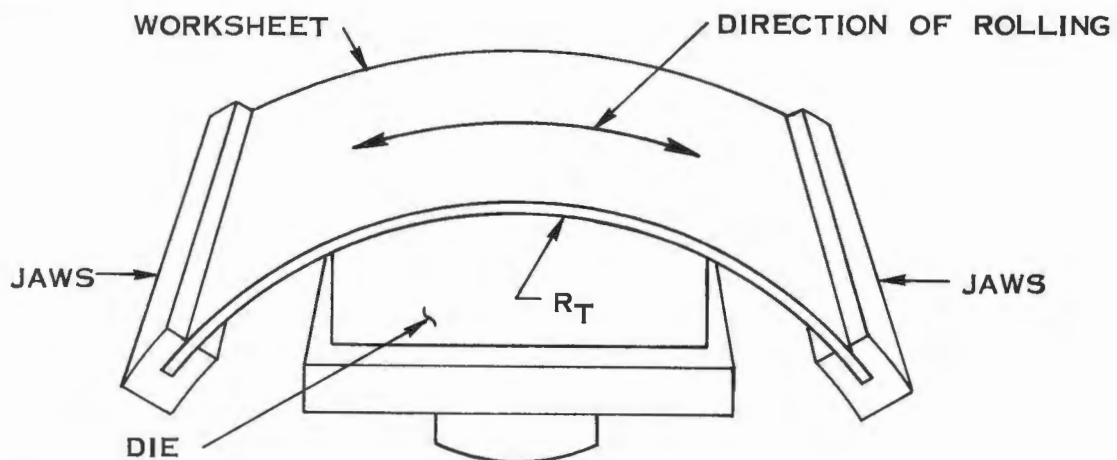

SET-UP CONSIDERING THE DIRECTION OF ROLL OF THE MATERIAL
 FIGURE IVA-3

In most cases even though the work sheet does not stretch completely over the die, splitting does not occur in the formed area, but rather in that region between the edge of the die and the jaws of the stretch press. This means that even if a part has split, it is still useful. The few exceptions to this are those materials which are very brittle. These brittle materials on occasions split at the crown of the die rendering the piece useless. Of the materials stretched in this program only HM21XA-T8 split at the crown of the most severe dies.

The sheet stretch process is not concerned with the gage of a material, but rather with the elongation. If all other properties are equal the thickness will have no effect on the formability. This means that work sheets of the same material and of varying gages when stretched over the same die will be approximately equal in size.

Predictability Equations

The basic equation to correlate conventional strain to sheet stretch parameters:

$$\epsilon = \left[2 \left(\frac{R}{L} \right) \text{CSC}^{-1} 2 \left(\frac{R}{L} \right) - 1 \right] \quad \text{Equation I}$$

The formability indice used for this program:

$$\epsilon = f(\epsilon_{2.0}) = \frac{\epsilon_{2.0}}{4}$$

The specific equation for finding (R/L) value when $\epsilon_{2.0}$ is known:

$$\epsilon_{2.0} = 4 \left[2 \left(\frac{R}{L} \right) \text{CSC}^{-1} 2 \left(\frac{R}{L} \right) - 1 \right] \quad \text{Equation II}$$

The equation showing relationship of sheet stretch parameters:

$$\frac{R_T}{T} \times \frac{R_L}{L} = C$$

Equation III

Where:

C = constant

R_L = radius perpendicular to direction of pull

R_T = radius parallel to direction of pull.

L = chord length of R_L and/or of R

T = chord length of R_T

R = radius when $R/L = R_T/T = R_L/L$

In order to find the value for $\epsilon_{2.0}$ a tension test specimen is gridded with 2 inch squares. The specimen is pulled and a grid at the point of failure is measured to find the change in length (ΔL) caused by the strain. (See Figure IV A-4).

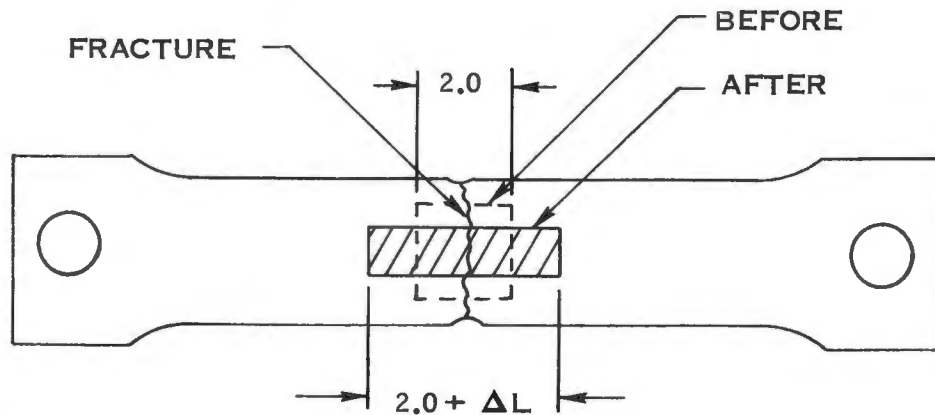

TYPICAL GRIDDED TENSION SPECIMEN
FIG. IV A-4

After measuring ΔL use this equation to find $\epsilon_{2.0}$:

$$\epsilon_{2.0} = \frac{\Delta L}{2.0}$$

Equation IV

It is now possible to use equation II and plot a curve for all R/L values and all values of $\epsilon_{2.0}$. Then by pulling a tension specimen of a given material it is possible to use this curve to find the particular R/L value for that material. With this R/L value it would then become possible to construct a graph showing all R_T/T and R_L/L values for that material.

PROBLEM: Construct a graph showing all R_T/T and R_L/L values.

GIVEN: $\epsilon_{2.0} = 0.3$ (from tension specimen)

Step I. Construct a graph with R/L as the ordinate and $\epsilon_{2.0}$ as the abscissa.

Step II. Plot Equation II $\epsilon_{2.0} = 4 [2(R/L) \text{CSC}^{-1} 2(R/L) - 1]$ on the graph. (See Figure IV A-5).

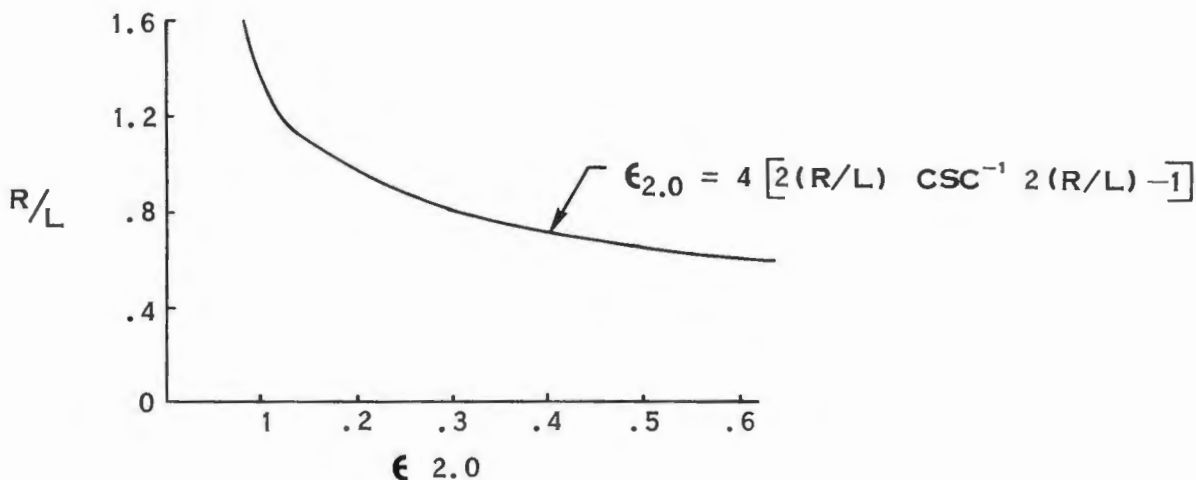

PLOTTING EQUATION II
FIG. IV A-5

Step III. Locate the given value of $\epsilon_{2.0}$ ($\epsilon_{2.0} = 0.3$ from tension specimen) on the abscissa.

Step IV. Construct a vertical line from this point until intersecting the curve.

Step V. At the point of intersection construct a horizontal line back to the ordinate.

Step VI. Read the R/L value at the ordinate. (See Figure IV A-6).
(R/L = .82)

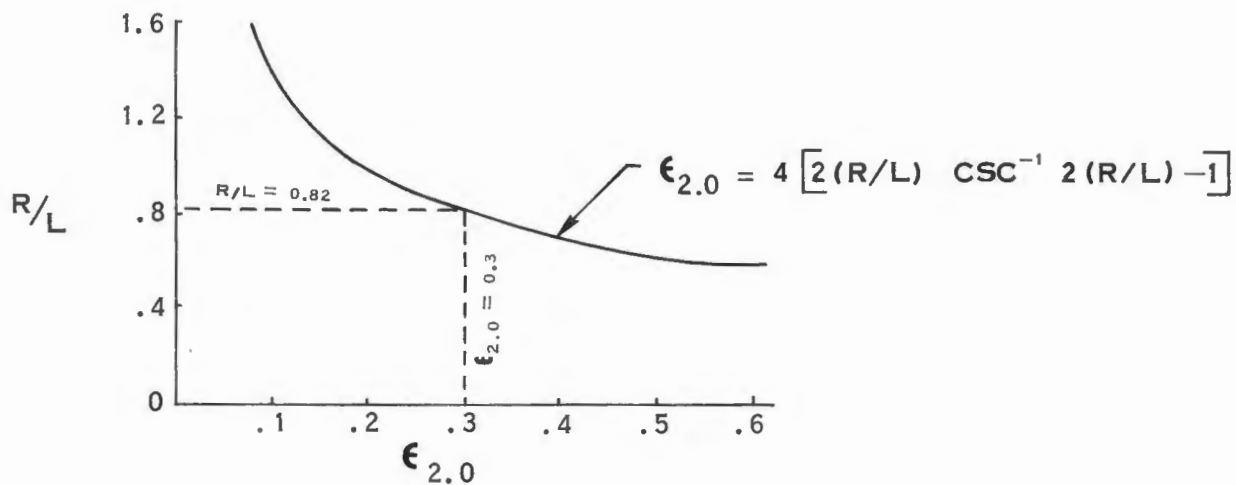

FINDING THE R/L VALUE
FIG. IV A-6

Step VII. Construct a graph on log-log paper with R_T/T as the ordinate and R_L/L as the abscissa.

Step VIII. Next construct a 45° index line passing through $R_T/T = R_L/L = .1$ and R_T/T and $R_L/L = .5$.
($R_T/T = R_L/L = .5$ is the theoretical limit for sheet stretch.) (See Figure IV A-7).

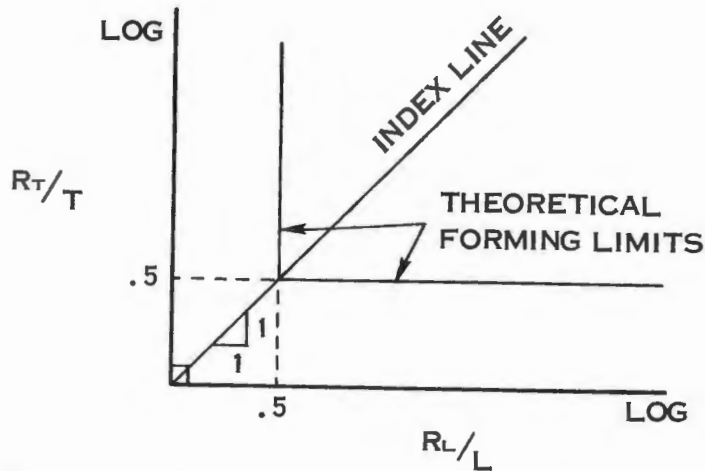

PLOTTING INDEX AND THEORETICAL LIMITS
FIG. IV A-7

Step IX. On the index line plot the value of R/L taken from the first graph. ($R/L = .82$ so $R/L = R_T/T = R_L/L = 0.82$). Through this point construct a line perpendicular to the index line.

Step X. This line is the forming limit for the particular material. The constant (C) for this material is $(0.82)^2$ so from Equation III $R_T/T \times R_L/L = (0.82)^2$. (See Figure IV A-8).

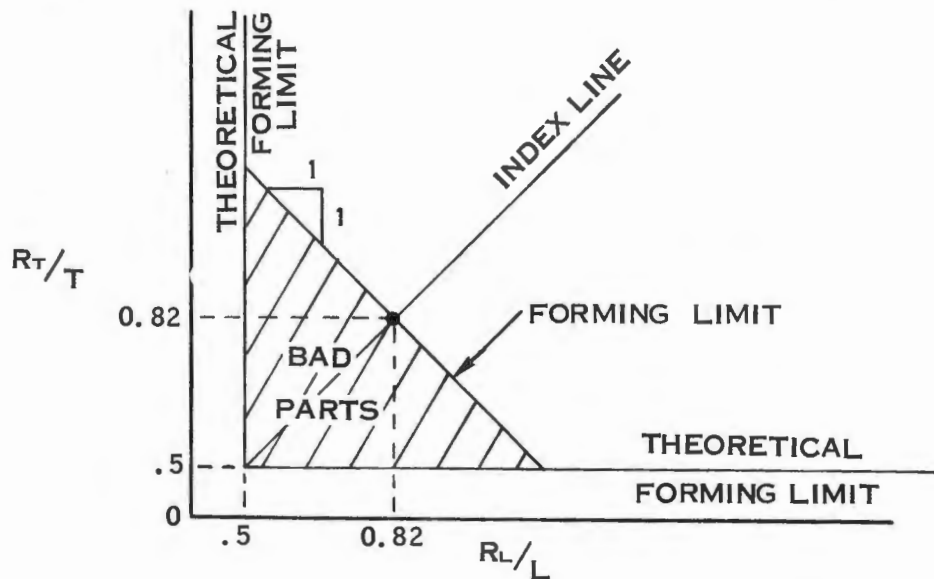

PLOTTING THE FORMING LIMITS
FIG. IV A-8

Composite Graphs

For a composite graph showing the correlation of the R/L values for the materials in this program to $\epsilon_{2.0}$ see Graph IV A-1. For a composite graph of the forming limits see Graph IV A-2.

It might prove possible in some instances to extend the forming limits for a specific material by reducing the strain rate effect (slower forming), reducing surface roughness of both material and die, or by the application of heat. The forming limits of HM21XA-T8 were extended by the application of heat and appear in Graph IV A-2.

Tungsten and Beryllium were omitted from the Sheet Stretch phase of the program because these materials fracture when clamped in the jaws of the stretch press. If double contouring of these materials is necessary it is suggested that matched, heated dies be used.

GRAPH IV A-1

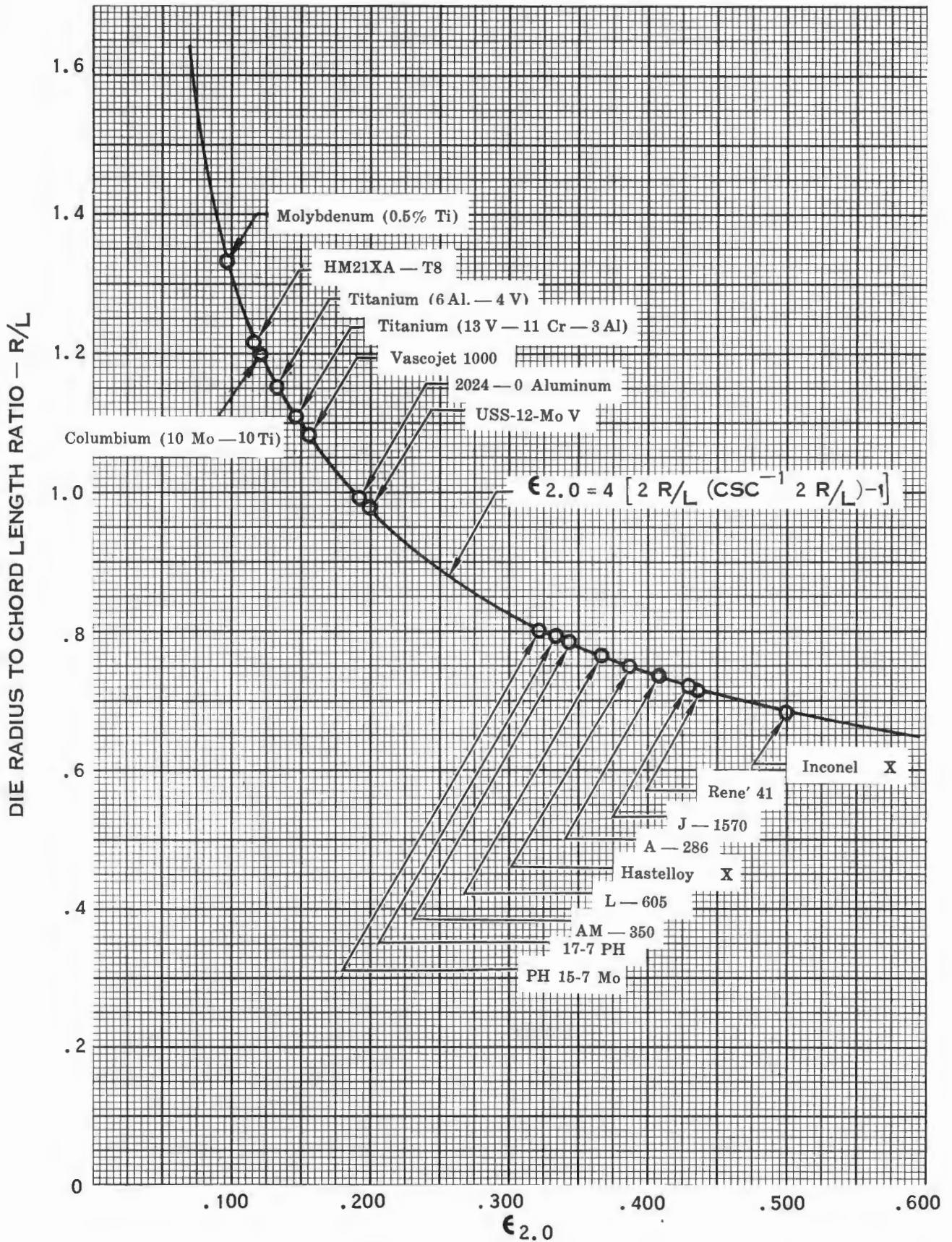

SHEET STRETCH CORRELATION GRAPH

GRAPH IV A-2

SHEET STRETCH
COMPOSITE GRAPH FOR FORMING LIMITS

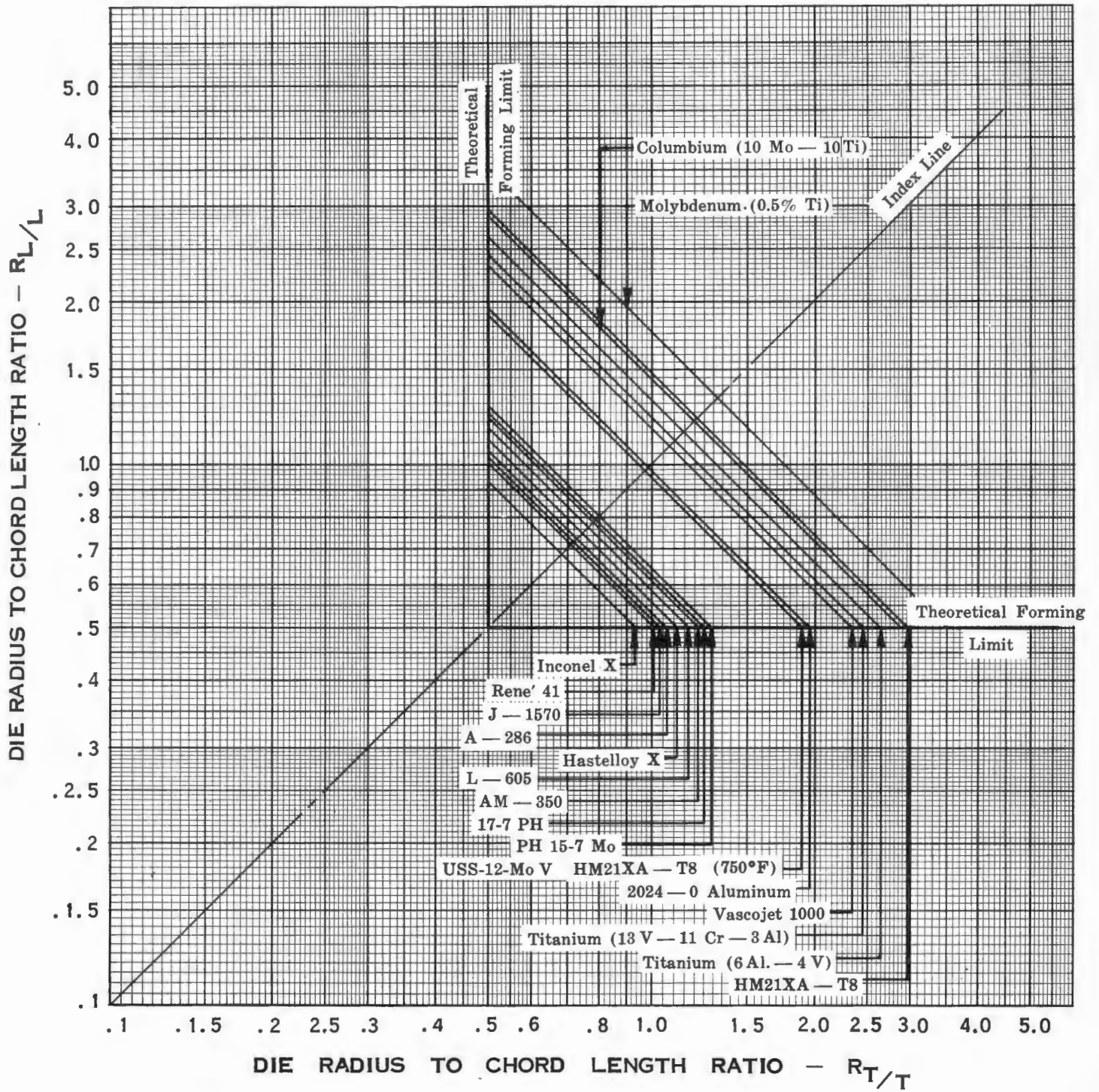

Design Tables

The sheet stretch design tables present a chord length for a given radius. It should be noted that these values are given for the maximum forming limits of the various materials.

To use the design tables note that the vertical columns represent both R_L and R_T values. Each horizontal column is divided with the chord length (L) being in the top half of the divided rectangle and the chord length (T) being in the bottom half.

- (1) Select the correct table for the material.
- (2) Select the radius desired for (R_T).
- (3) Read down the vertical column until crossing the (T) value desired on a horizontal column.
- (4) Staying on the same horizontal column move to the right underneath the desired radius (R_L), then read the value for (L) in the top half of the rectangle.

TABLE IV A-1
SHEET STRETCH
FORMING LIMITS FOR HM21XA-T8
(MAGNESIUM THORIUM)

		Die Radii - R_T Or R_L									
		10	20	30	40	50	60	70	80	90	100
C H O R D L E N G T H	L	8.03	16.1	24.1	32.1	40.2	48.2	56.2	64.2	72.3	80.3
	T	8.03	16.1	24.11	32.1	40.2	48.2	56.2	64.2	72.3	80.3
	L	7.1	14.3	21.4	28.6	35.7	42.8	50.0	57.1	64.3	71.4
	T	9.05	18.1	27.2	36.2	45.2	54.3	63.4	72.4	81.4	90.5
	L	6.4	12.7	19.1	25.5	31.8	38.2	44.6	51.0	57.3	63.7
	T	10.1	20.2	30.3	40.4	50.5	60.6	70.7	80.8	90.9	101
	L	5.6	11.2	16.8	22.5	28.1	33.7	39.3	44.9	50.6	56.2
	T	11.5	23.0	34.5	46.0	57.5	69.0	80.4	92.0	103	115
	L	5.1	10.1	15.2	20.2	25.3	30.4	35.4	40.5	45.6	50.6
	T	12.8	25.6	38.5	51.3	64.1	76.9	89.7	102	115	128
	L	4.6	9.2	13.8	18.4	23.0	27.6	32.2	36.9	41.5	46.1
	T	14.1	28.2	42.2	56.3	70.4	84.5	98.6	113	127	141
	L	4.2	8.3	12.5	16.6	20.8	24.9	29.1	33.3	37.4	41.6
	T	15.5	31.0	46.5	62.0	77.5	93.0	108	124	140	155
	L	3.8	7.7	11.5	15.3	19.2	23.0	26.8	30.6	34.5	38.3
	T	16.9	33.9	50.8	67.8	84.7	102	119	136	152	169
	L	3.5	7.0	10.5	14.0	17.5	21.0	24.5	28.0	31.5	35.0
	T	18.5	37.0	55.6	74.1	92.6	111	130	148	167	185
	L	3.3	6.6	9.8	13.1	16.4	19.7	23.0	26.2	29.5	32.8
	T	20.0	40.0	60.0	80.0	100	120	140	160	180	200

TABLE IV A-2
SHEET STRETCH
FORMING LIMITS FOR HM21XA-T8
(MAGNESIUM THORIUM)
(750°F)

		Die Radii - R_T Or R_L									
		10	20	30	40	50	60	70	80	90	100
C H O R D L E N G T H	L	10.4	20.8	31.2	41.7	52.1	62.5	72.9	83.3	93.7	104
	T	10.4	20.8	31.2	41.7	52.1	62.5	72.9	83.3	93.7	104
	L	9.6	19.1	28.7	38.3	47.8	57.4	67.0	76.6	86.1	95.7
	T	11.3	22.6	33.9	45.2	56.5	67.8	79.1	90.4	102	113
	L	8.8	17.5	26.3	35.1	43.8	52.6	61.4	70.2	78.9	87.7
	T	12.3	24.7	37.0	49.4	61.7	74.1	86.4	98.8	111	123
	L	8.0	16.1	24.1	32.1	40.2	48.2	56.2	64.2	72.3	80.3
	T	13.5	27.0	40.5	54.0	67.6	81.1	94.6	108	122	135
	L	7.5	15.0	22.5	30.0	37.4	44.9	52.5	59.9	67.4	74.9
	T	14.5	29.0	43.5	58.0	72.5	87.0	101	116	130	145
	L	7.0	14.0	21.0	28.0	35.0	42.0	49.0	55.9	62.9	69.9
	T	15.5	31.0	46.5	62.0	77.5	93.0	108	124	140	155
L	6.5	13.1	19.6	26.1	32.7	39.2	45.8	52.3	58.8	65.4	
T	16.7	33.4	50.1	66.8	83.5	100	117	134	150	167	
L	6.1	12.2	18.3	24.4	30.5	36.6	42.7	48.8	54.9	61.0	
T	17.8	35.6	53.9	71.2	89.0	107	124	142	160	178	
L	5.7	11.5	17.2	23.0	28.7	34.5	40.2	46.0	51.7	57.5	
T	18.9	37.9	56.8	75.8	94.7	114	132	152	170	189	
L	5.4	10.9	16.3	21.7	27.2	32.6	38.0	43.5	48.9	54.3	
T	20	40	60	80	100	120	140	160	180	200	

TABLE IV A-3
SHEET STRETCH
FORMING LIMITS FOR 2024-O ALUMINUM

		Die Radii - R_T Or R_L									
		10	20	30	40	50	60	70	80	90	100
C H O R D L E N G T H	L	10.3	20.6	30.9	41.2	51.5	61.2	72.2	82.5	92.8	103
	T	10.3	20.6	30.9	41.2	51.5	61.8	72.2	82.5	92.8	103
	L	9.5	19.0	28.4	37.9	47.4	56.9	66.4	75.8	85.3	94.8
	T	11.2	22.3	33.5	44.7	55.9	67.0	78.2	89.4	100	112
	L	8.7	17.4	26.1	34.8	43.5	52.2	60.9	69.6	78.3	87.0
	T	12.2	24.4	36.6	48.8	61.0	73.2	85.4	97.6	110	122
	L	8.0	16.0	24.0	32.0	40.0	48.0	56.0	64.0	72.0	80.0
	T	13.3	26.7	40.0	53.3	66.7	80.0	93.3	107	120	133
	L	7.4	14.7	22.0	29.4	36.8	44.1	51.5	58.8	66.2	73.5
	T	14.4	28.8	43.2	57.6	71.9	86.3	101	115	129	144
	L	6.8	13.7	20.5	27.4	34.2	41.1	47.9	54.8	61.6	68.5
	T	15.4	30.8	46.2	61.5	76.9	92.3	108	123	138	154
	L	6.4	12.7	19.1	25.5	31.8	38.2	44.6	51.0	57.3	63.7
	T	16.6	33.3	49.9	66.6	83.2	99.8	116	133	150	166
	L	6.0	12.0	18.0	24.0	29.9	35.9	41.9	47.9	53.9	59.9
	T	17.7	35.5	53.2	70.9	88.6	106	124	142	160	177
	L	5.6	11.2	16.8	22.5	28.1	33.7	39.3	44.9	50.6	56.2
	T	18.9	37.8	56.7	75.6	94.5	113	132	151	170	189
	L	5.3	10.6	16.0	21.3	26.6	31.9	37.2	42.6	47.9	53.2
	T	20	40	60	80	100	120	140	160	180	200

TABLE IV A-4
 SHEET STRETCH
 FORMING LIMITS FOR 17-7 Ph
 (CONDITION "A" MILL ANNEALED)

ASD TR 61-191(II)

IV-16

		Die Radii - R_T Or R_L									
		10	20	30	40	50	60	70	80	90	100
CHORD LENGTH	L	12.8	25.6	38.4	51.3	64.1	76.9	89.8	102	115	128
	T	12.8	25.6	38.4	51.3	64.1	76.9	89.8	102	115	128
	L	12.2	24.4	36.6	48.8	61.0	73.2	85.4	97.6	110	122
	T	13.5	27.0	40.5	54.0	67.5	81.0	94.5	108	122	135
	L	11.6	23.2	34.9	46.5	58.1	69.8	81.4	93.0	105	116
	T	14.2	28.4	42.7	57.0	71.2	85.5	99.7	114	128	142
	L	11.0	22.1	33.2	44.2	55.2	66.3	77.4	88.4	99.5	110
	T	14.9	29.8	44.7	59.7	74.6	89.5	104	119	134	149
	L	10.5	20.9	31.4	41.8	52.3	62.8	73.3	83.8	94.2	105
	T	15.6	31.2	46.8	62.5	78.1	93.8	109	125	141	156
	L	10.0	20.1	30.1	40.2	50.2	60.3	70.4	80.4	90.5	100
	T	16.5	33.1	49.6	66.2	82.7	99.3	116	132	149	165
	L	9.5	19.1	28.6	38.1	47.6	57.1	66.6	76.2	85.7	95.2
	T	17.2	34.4	51.7	68.9	86.2	103	121	138	155	172
	L	9.1	18.2	27.3	36.4	45.5	54.6	63.7	72.8	81.9	91.0
	T	18.2	36.4	54.6	72.8	91.0	109	127	145	163	182
	L	8.7	17.4	26.1	34.8	43.5	52.2	60.9	69.6	78.3	87.0
	T	19.0	37.9	56.8	75.8	94.8	114	133	152	171	190
	L	8.3	16.5	24.8	33.1	41.4	49.7	57.9	66.2	74.5	82.8
	T	20	40	60	80	100	120	140	160	180	200

TABLE IV A-5
 SHEET STRETCH
 FORMING LIMITS FOR Ph 15-7 Mo
 (CONDITION "A" MILL ANNEALED)

		Die Radii - R_T Or R_L									
		10	20	30	40	50	60	70	80	90	100
CHORD LENGTH	L	12.7	25.3	38.0	50.6	63.3	76.0	88.6	101	114	127
	T	12.7	25.3	38.0	50.6	63.3	76.0	88.6	101	114	127
	L	11.9	23.8	35.7	47.6	59.5	71.4	83.3	95.2	107	119
	T	13.3	26.7	40.0	53.3	66.7	80.0	93.3	107	120	133
	L	11.4	22.7	34.1	45.5	56.8	68.2	79.5	90.9	102	114
	T	14.0	28.0	42.0	56.0	70.0	84.0	98.0	112	126	140
	L	10.8	21.6	32.4	43.2	54.0	64.8	75.6	86.4	97.2	108
	T	14.8	29.6	44.5	59.3	74.1	88.9	104	119	133	148
	L	10.3	20.6	30.9	41.2	51.5	61.9	72.2	82.6	92.9	103
	T	15.5	31.0	46.5	62.0	77.5	93.0	108	124	140	155
	L	9.8	19.6	29.4	39.2	49.0	58.8	68.6	78.4	88.2	98.0
	T	16.2	31.5	48.8	65.0	81.2	97.5	114	130	146	162
	L	9.4	18.7	28.0	37.4	46.7	56.0	65.4	74.7	84.0	93.5
	T	17.2	34.5	51.7	69.0	86.2	103	120	138	155	172
	L	8.8	17.7	26.6	35.4	44.3	53.1	62.0	70.8	79.6	88.5
	T	18.0	36.0	54.0	72.0	90.0	108	126	144	162	180
	L	8.5	17.0	25.4	33.9	42.4	50.9	59.4	67.8	76.3	84.8
	T	18.9	27.8	56.6	75.5	94.4	113	132	151	170	189
	L	8.0	16.0	24.0	32.0	40.0	48.0	56.0	64.0	72.0	80.0
	T	20	40	60	80	100	120	140	160	180	200

TABLE IV A-6
SHEET STRETCH
FORMING LIMITS FOR AM-350
(ANNEALED)

		Die Radii - R _T Or R _L									
		10	20	30	40	50	60	70	80	90	100
C H O R D L E N G T H	L	12.9	25.8	38.7	51.6	64.5	77.4	90.3	103	116	129
	T	12.9	25.8	38.7	51.6	64.5	77.4	90.3	103	116	129
	L	12.3	24.6	36.8	49.1	61.4	73.6	85.9	98.1	110	123
	T	13.6	27.2	40.8	54.4	68.0	81.6	95.2	109	122	136
	L	11.7	23.4	35.1	46.8	58.5	70.2	81.9	93.6	105	117
	T	14.3	28.6	42.8	57.1	71.4	85.7	100	114	129	143
	L	11.1	22.2	33.3	44.4	55.6	66.7	77.8	88.9	100	111
	T	15.0	30.1	45.1	60.1	75.1	90.2	105	120	135	150
	L	10.6	21.3	31.9	42.6	53.2	63.8	74.5	85.1	95.8	106
	T	15.6	31.2	46.8	62.5	78.1	93.7	109	125	141	156
	L	10.2	20.4	30.6	40.8	51.0	61.2	71.4	81.6	91.8	102
	T	16.5	33.1	49.6	66.2	82.8	99.3	116	132	149	165
	L	9.7	19.4	29.1	38.8	48.5	58.2	68.0	77.7	87.4	97.1
	T	17.2	34.5	51.7	69.0	86.2	103	121	138	155	172
	L	9.2	18.5	27.7	37.0	46.3	55.6	64.8	74.1	83.3	92.5
	T	18.2	36.4	54.5	72.7	90.9	109	127	145	164	182
L	8.8	17.7	26.6	35.4	44.2	53.1	61.9	70.8	79.7	88.5	
T	19.0	37.9	56.8	75.8	94.8	114	133	152	170	190	
L	8.5	17.0	25.4	33.9	42.4	50.8	59.3	67.8	76.3	84.8	
T	20	40	60	80	100	120	140	160	180	200	

TABLE IV A-7
 SHEET STRETCH
 FORMING LIMITS FOR A-286
 (SOLUTION TREATED CONDITION)

		Die Radii - R_T Or R_L									
		10	20	30	40	50	60	70	80	90	100
C H O R D L E N G T H	L	13.7	27.4	41.1	54.8	68.5	82.2	95.9	110	123	137
	T	13.7	27.4	41.1	54.8	68.5	82.2	95.9	110	123	137
	L	13.2	26.3	39.5	52.6	65.8	79.0	92.1	105	118	132
	T	14.3	28.6	42.9	57.2	71.5	85.8	100	114	129	143
	L	12.7	25.3	38.0	50.6	63.3	76.0	88.6	101	114	127
	T	14.9	29.9	44.8	59.8	74.7	89.7	105	120	134	149
	L	12.0	24.1	36.1	48.2	60.2	72.2	84.3	96.3	108	120
	T	15.6	31.2	46.9	62.5	78.1	93.8	109	125	141	156
	L	11.6	23.1	34.7	45.2	57.8	69.4	81.0	92.5	104	116
	T	16.2	32.5	48.8	65.0	81.2	97.5	114	130	146	162
	L	11.1	22.2	33.3	44.4	55.6	66.7	77.8	88.9	100	111
	T	16.8	33.6	50.4	67.2	84.0	101	118	134	151	168
	L	10.6	21.3	31.9	42.5	53.2	63.8	74.5	85.1	95.7	106
	T	17.6	35.2	52.8	70.5	88.1	106	123	141	158	176
	L	10.2	20.5	30.8	41.0	51.3	61.5	71.8	82.1	92.3	102
	T	18.4	36.7	55.0	73.4	91.8	110	128	147	165	184
	L	9.9	19.8	29.7	39.6	49.5	59.5	69.4	79.3	89.2	99.1
	T	19.0	38.1	57.1	76.2	95.3	114	133	152	171	190
	L	9.4	18.9	28.3	37.8	47.2	56.6	66.1	75.5	85.0	94.5
	T	20	40	60	80	100	120	140	160	180	200

TABLE IV A-8
SHEET STRETCH
FORMING LIMITS FOR USS-12-MoV
(ANNEALED)

		Die Radii - R_T Or R_L									
		10	20	30	40	50	60	70	80	90	100
C H O R D L E N G T H	L	10.4	20.8	31.2	41.7	52.1	62.5	72.9	83.3	93.7	104
	T	10.4	20.5	31.2	41.7	52.1	62.5	72.9	83.3	93.7	104
	L	9.6	19.1	28.7	38.3	47.8	57.4	67.0	76.6	86.1	95.7
	T	11.3	22.6	33.9	45.2	56.5	67.8	79.1	90.4	102	113
	L	8.8	17.5	26.3	35.1	43.8	52.6	61.4	70.2	78.9	87.7
	T	12.3	24.7	37.0	49.4	61.7	74.1	86.4	98.8	111	123
	L	8.0	16.1	24.1	32.1	40.2	48.2	56.2	64.2	72.3	80.3
	T	13.5	27.0	40.5	54.0	67.6	81.1	94.6	108	122	135
	L	7.5	15.0	22.5	30.0	37.4	44.9	52.4	59.9	67.4	74.9
	T	14.5	29.0	43.5	58.0	72.5	87.0	101	116	130	145
	L	7.0	14.0	21.0	28.0	35.0	42.0	49.0	55.9	62.9	69.9
	T	15.5	31.0	46.5	62.0	77.5	93.0	108	124	140	155
	L	6.5	13.1	19.6	26.1	32.7	39.2	45.8	52.3	58.8	65.4
	T	16.7	33.4	50.1	66.8	83.5	100	117	134	150	167
	L	6.1	12.2	18.3	24.4	30.5	36.6	42.7	48.8	54.9	61.0
	T	17.8	35.6	53.4	71.2	89.0	107	124	142	160	178
	L	5.7	11.5	17.2	23.0	28.7	34.5	40.2	46.0	51.7	57.5
	T	18.9	37.9	56.8	75.8	94.7	114	132	152	170	189
L	5.4	10.9	16.3	21.7	27.2	32.6	38.0	43.5	48.9	54.3	
T	20	40	60	80	100	120	140	160	180	200	

ASD TR 61-191(II)

IV-20

TABLE IV A-9
SHEET STRETCH
FORMING LIMITS FOR TITANIUM (6Al-4V)
(MILL ANNEALED)

		Die Radii - R_T Or R_L									
		10	20	30	40	50	60	70	80	90	100
C H O R D L E N G T H	L	9.1	18.2	27.3	36.4	45.4	54.5	63.6	72.7	81.8	90.9
	T	9.1	18.2	27.3	36.4	45.4	54.5	63.6	72.7	81.8	90.9
	L	8.3	16.7	25.0	33.3	41.7	50.0	58.3	66.7	75.0	83.3
	T	10.0	20.0	30.0	40.0	50.0	60.0	70.0	80.0	90.0	100.0
	L	7.6	15.2	22.7	30.3	37.9	45.4	53.0	60.6	68.2	75.8
	T	10.9	21.7	32.6	43.5	54.3	65.2	76.1	87.0	97.8	109
	L	7.0	14.0	21.0	28.0	35.0	42.0	49.0	55.9	62.9	69.9
	T	11.8	23.5	35.3	47.1	58.8	70.6	82.4	94.1	106	118
	L	6.4	12.8	19.2	25.6	32.0	38.5	44.9	51.3	57.7	64.1
	T	13.0	26.0	39.0	51.9	64.9	77.9	90.9	104	117	130
	L	5.9	11.8	17.6	23.5	29.4	35.3	41.2	47.0	52.9	58.8
	T	14.1	28.2	42.2	56.3	70.4	84.5	98.6	113	127	141
	L	5.4	10.8	16.1	21.5	26.9	32.2	37.6	43.0	48.4	53.8
	T	15.3	30.5	45.8	61.1	76.3	91.6	107	122	137	153
	L	4.9	9.8	14.8	19.7	24.6	29.6	34.5	39.4	44.3	49.3
	T	16.8	33.6	50.4	67.2	84.0	101	118	134	151	168
	L	4.5	9.0	13.4	17.9	22.4	26.9	31.4	35.9	40.4	44.8
	T	18.3	36.7	55.0	73.4	91.7	110	128	147	165	183
	L	4.1	8.3	12.4	16.6	20.7	24.9	29.0	33.2	37.3	41.5
	T	20	40	60	80	100	120	140	160	180	200

TABLE IV A-10
 SHEET STRETCH
 FORMING LIMITS FOR TITANIUM (13V-11Cr-3Al)
 (SOLUTION TREATED)

		Die Radii - R_T Or R_L									
		10	20	30	40	50	60	70	80	90	100
C H O R D L E N G T H	L	9.5	19	28.4	37.9	47.4	56.9	66.4	75.8	85.3	94.8
	T	9.5	19.0	28.4	37.9	47.4	56.9	66.4	75.8	85.3	94.8
	L	8.7	17.4	26.1	34.8	43.5	52.2	60.9	69.6	78.3	87.0
	T	10.4	20.7	31.1	41.4	51.8	62.2	72.5	82.9	93.3	104
	L	8.9	17.8	26.7	35.6	44.4	53.3	62.2	71.1	80.0	88.9
	T	11.2	22.3	33.5	44.7	55.9	67.0	78.2	89.4	100	112
	L	7.4	14.7	22.0	29.4	36.8	44.1	51.5	58.8	66.2	73.5
	T	12.2	24.4	36.6	48.8	61.0	73.2	85.4	97.6	110	122
	L	6.8	13.5	20.3	27.0	33.8	40.5	47.3	54.0	60.8	67.6
	T	13.3	26.7	40.0	53.3	66.7	80.0	93.3	107	120	133
	L	6.2	12.5	18.8	25.0	31.2	37.5	43.8	50.0	56.2	62.5
	T	14.4	28.8	43.2	57.6	71.9	86.3	101	115	129	144
L	5.8	11.5	17.3	23.0	28.8	34.6	40.3	46.1	51.9	57.6	
T	15.5	31.0	46.5	62.0	77.5	93.0	108	124	140	155	
L	5.3	10.6	16.0	21.3	26.6	31.9	37.2	42.6	47.9	53.2	
T	16.9	33.8	50.7	67.6	84.5	101	118	135	152	169	
L	4.8	9.7	14.6	19.4	24.3	29.1	34.0	38.8	43.7	48.5	
T	18.4	36.8	55.1	73.5	91.9	110	129	147	165	184	
L	4.5	9.0	13.5	18.0	22.5	27.0	31.5	36.0	40.5	45.0	
T	20	40	60	80	100	120	140	160	180	200	

TABLE IV A-11
SHEET STRETCH
FORMING LIMITS FOR VASCOJET 1000 (H-11)
(ANNEALED)

		Die Radii - R_T Or R_L									
		10	20	30	40	50	60	70	80	90	100
C H O R D L E N G T H	L	9.8	19.7	29.6	39.4	49.3	59.1	69.0	78.8	88.7	98.5
	T	9.8	19.7	29.6	39.4	49.3	59.1	69.0	78.8	88.7	98.5
	L	9.0	17.9	26.9	35.9	44.8	53.8	62.8	71.7	80.7	89.7
	T	10.8	21.5	32.2	43.0	53.8	64.5	75.3	86.0	96.8	108
	L	8.1	16.3	24.4	32.5	40.6	48.8	56.9	65.0	73.2	81.3
	T	11.8	23.5	35.3	47.1	58.8	70.6	82.4	94.1	106	118
	L	7.4	14.9	22.3	29.7	37.2	44.6	52.0	59.5	66.9	74.3
	T	13.0	26.0	39.0	51.9	64.9	77.9	90.9	104	117	130
	L	6.8	13.7	20.5	27.4	34.2	41.1	47.9	54.8	61.6	68.5
	T	14.1	28.2	42.2	56.3	70.4	84.5	98.6	113	127	141
	L	6.3	12.6	19.0	25.3	31.6	38.0	44.3	50.6	57.0	63.3
	T	15.2	30.4	45.6	60.8	76.0	91.2	106	122	137	152
	L	5.9	11.8	17.6	23.5	29.4	35.3	41.2	47.0	52.9	58.8
	T	16.5	33.0	49.6	66.1	82.6	99.2	116	132	149	165
	L	5.5	11.0	16.5	22.0	27.5	33.0	38.5	44.0	49.4	54.9
	T	17.6	35.2	52.7	70.3	87.9	105	123	141	158	176
L	5.1	10.2	15.4	20.5	25.6	30.8	35.9	41.0	46.2	51.3	
T	18.9	37.7	56.6	75.5	94.3	113	132	151	170	189	
L	4.8	9.7	14.5	19.3	24.2	29.0	33.8	38.6	43.5	48.3	
T	20	40	60	80	100	120	140	160	180	200	

TABLE IV A-12
 SHEET STRETCH
 FORMING LIMITS FOR RENE '41
 (SOLUTION TREATED)

ASD TR 61-191(II)

IV-24

		Die Radii - R_T Or R_L									
		10	20	30	40	50	60	70	80	90	100
C H O R D L E N G T H	L	14.0	28.0	42.0	56.0	70.0	84.0	98.0	112	126	140
	T	14.0	28.0	42.0	56.0	70.0	84.0	98.0	112	126	140
	L	13.5	27.0	40.5	54.0	67.5	81.1	94.6	108	122	135
	T	14.7	29.4	44.1	58.8	73.5	88.3	103	118	132	147
	L	13.0	26.0	39.0	52.0	65.0	78.0	91.0	104	117	130
	T	15.2	30.3	45.4	60.6	75.8	90.9	106	121	136	152
	L	12.5	25.0	37.5	50.0	62.5	75.0	87.5	100	112	125
	T	15.9	31.8	47.6	63.5	79.4	95.2	111	127	143	159
	L	12.2	24.4	36.6	48.8	61.0	73.2	85.4	97.6	110	122
	T	16.4	32.9	49.4	65.6	82.2	98.7	115	131	147	164
L	11.6	23.1	34.7	46.3	57.8	69.4	81.0	92.5	104	116	
T	17.1	34.2	51.3	60.4	85.5	102	120	137	154	171	
L	11.1	22.2	33.3	44.4	55.6	66.7	77.8	88.9	100	111	
T	17.8	35.7	53.5	71.4	89.2	107	125	143	161	178	
L	10.6	21.2	31.9	42.5	53.2	63.8	74.5	85.1	95.8	106	
T	18.4	36.8	55.3	73.7	92.1	111	129	147	166	184	
L	10.3	20.6	30.9	41.2	51.5	61.8	72.2	82.5	92.8	103	
T	19.2	38.4	57.5	76.8	96.0	115	134	153	173	192	
L	10	20	30	40	50	60	70	80	90	100	
T	20	40	60	80	100	120	140	160	180	200	

TABLE IV A-13
SHEET STRETCH
FORMING LIMITS FOR INCONEL X
(C. R. ANNEALED)

		Die Radii - R_T Or R_L									
		10	20	30	40	50	60	70	80	90	100
C H O R D L E N G T H	L	14.6	29.2	43.8	58.4	73.0	87.6	102	117	131	146
	T	14.6	29.2	43.8	58.4	73.0	87.6	102	117	131	146
	L	14.2	28.4	42.5	56.7	70.8	85.0	99.2	113	128	142
	T	15.1	30.3	45.4	60.6	75.7	90.8	106	121	136	151
	L	13.6	27.2	40.8	54.6	68.0	81.6	95.2	109	123	136
	T	15.6	31.2	46.8	62.4	78.0	93.6	109	125	140	156
	L	13.2	26.3	39.5	52.6	65.8	78.9	92.1	105	118	132
	T	16.3	32.5	48.8	65.0	81.3	97.5	114	130	146	163
	L	12.6	25.3	38.0	50.6	63.2	75.9	88.5	101	114	126
	T	16.8	33.6	50.4	67.2	84.0	101	118	135	151	168
	L	12.3	24.7	37.0	49.4	61.7	74.1	86.5	98.8	111	123
	T	17.4	34.8	52.2	69.6	87.0	104	122	139	156	174
L	11.8	22.6	35.5	47.4	55.2	71.0	82.8	91.6	106	118	
T	18.1	36.2	54.3	72.4	90.5	109	127	145	163	181	
L	11.5	23.0	34.5	46.0	57.5	69.0	80.5	92.0	104	115	
T	18.6	37.2	55.7	74.4	92.9	111	130	149	167	186	
L	11.1	22.2	33.4	44.5	55.6	66.7	77.8	89.0	100	111	
T	19.2	38.4	57.7	77.0	96.2	115	135	154	173	192	
L	10.7	21.4	32.1	42.8	53.5	64.2	74.9	85.6	96.3	107	
T	20	40	60	80	100	120	140	160	180	200	

TABLE IV A-14
SHEET STRETCH
FORMING LIMITS FOR HASTELLOY X
(SOLUTION TREATED)

		Die Radii - R_T Or R_L									
		10	20	30	40	50	60	70	80	90	100
C H O R D L E N G T H	L	13.5	27.0	40.5	54.0	67.5	81.0	94.5	108	122	135
	T	13.5	27.0	40.5	54.0	67.5	81.0	94.5	108	122	135
	L	12.8	25.6	38.5	51.3	64.1	77.0	89.8	103	115	128
	T	14.2	28.3	42.5	56.7	70.9	85.0	99.2	113	128	142
	L	12.4	24.8	37.2	49.7	62.1	74.5	87.0	99.4	112	124
	T	14.7	29.4	44.1	58.8	73.5	88.2	103	118	132	147
	L	11.8	23.5	35.3	47.0	58.8	70.6	82.4	94.1	106	118
	T	15.4	30.8	46.2	61.5	76.9	92.3	108	123	138	154
	L	11.2	22.4	33.7	45.0	56.2	67.4	78.6	89.8	101	112
	T	16.0	32.0	48.0	64.0	80.0	96.0	112	128	144	160
	L	10.8	21.5	32.2	43.0	53.8	64.5	75.3	86.0	96.8	108
	T	16.7	33.3	50.0	66.7	83.3	100	117	133	150	167
	L	10.3	20.6	30.9	41.2	51.5	61.8	72.2	82.5	92.8	103
	T	17.5	35.1	52.6	70.2	87.8	105	123	140	158	175
	L	9.9	19.8	29.7	39.6	49.5	59.5	69.4	79.3	89.2	99.1
	T	18.2	36.4	54.6	72.8	91.0	109	127	146	164	182
	L	9.5	19.0	28.6	38.1	47.6	57.1	66.6	76.2	85.8	95.3
	T	19.0	38.1	57.1	76.2	95.2	114	133	152	171	190
	L	9.1	18.2	27.3	36.4	45.5	54.6	63.6	72.7	81.8	90.9
	T	20	40	60	80	100	120	140	160	180	200

TABLE IV A-15
 SHEET STRETCH FORMING LIMITS
 L-605
 (SOLUTION TREATED)

		Die Radii - R_T Or R_L									
		10	20	30	40	50	60	70	80	90	100
C H O R D L E N G T H	L	13.2	26.3	39.5	52.6	65.8	78.9	92.1	105	118	132
	T	13.2	26.3	39.5	52.6	65.8	78.9	92.1	105	118	132
	L	12.5	25.0	37.5	50.0	62.5	75.0	87.5	100	112	125
	T	13.9	27.8	41.6	55.5	69.4	83.3	97.2	111	125	139
	L	12.0	24.1	36.1	48.2	60.2	77.2	84.3	96.3	108	120
	T	14.5	29.0	43.5	58.0	72.5	87.0	101	116	130	145
	L	11.4	22.7	34.1	45.5	56.8	68.2	79.5	90.9	102	114
	T	15.1	30.3	45.4	60.6	75.7	90.9	106	121	136	151
	L	11.0	22.0	33.0	44.0	54.9	65.9	76.9	87.9	98.9	110
	T	15.9	31.8	47.6	63.5	79.4	95.3	111	127	143	159
	L	10.5	20.9	31.4	41.9	52.4	62.8	73.3	83.8	94.2	105
	T	16.7	33.3	50.0	66.7	83.3	100	117	133	150	167
	L	10	20	30	40	50	60	70	80	90	100
	T	17.4	34.8	52.2	69.6	87.0	104	122	139	156	174
	L	9.6	19.2	28.8	38.4	48.1	57.7	67.3	77.0	86.5	96.2
	T	18.2	36.4	54.5	72.7	90.9	109	127	145	164	182
	L	9.2	18.4	27.5	36.7	45.9	55.1	64.2	73.5	82.7	91.8
	T	19.0	38.1	57.1	76.2	95.3	114	133	152	171	190
	L	8.7	17.4	26.1	34.8	43.5	52.2	60.9	69.6	78.3	87.0
	T	20	40	60	80	100	120	140	160	180	200

TABLE IV A-16
 SHEET STRETCH FORMING LIMITS
 J-1570
 (SOLUTION TREATED)

ASD TR 61-191(II)

IV-28

		Die Radii - R_T Or R_L									
		10	20	30	40	50	60	70	80	90	100
C H O R D L E N G T H	L	13.9	27.8	41.7	55.6	69.5	83.4	97.3	111	125	139
	T	13.9	27.8	41.7	55.6	69.5	83.4	97.3	111	125	139
	L	13.3	26.7	40.0	53.3	66.7	80.0	93.3	107	120	133
	T	14.5	29.0	43.5	58.0	72.5	87.0	101	116	130	145
	L	12.8	25.6	38.4	51.3	64.1	76.9	89.8	103	115	128
	T	15.0	30.1	45.1	60.2	75.2	90.3	105	120	135	150
	L	12.3	24.5	36.8	49.0	61.3	73.6	85.9	98.1	110	123
	T	15.8	31.5	47.2	63.0	78.8	94.5	110	126	142	158
	L	12.0	24.1	36.1	48.2	60.2	72.3	84.3	96.4	108	120
	T	16.4	32.8	49.2	65.6	82.0	98.4	115	131	147	164
	L	11.4	22.8	34.3	45.7	57.2	68.6	80.0	91.5	103	114
	T	17.0	33.9	50.9	67.8	84.8	102	119	136	152	169
L	10.9	21.8	32.8	43.7	54.6	65.5	76.5	87.5	98.4	109	
T	17.7	35.4	53.1	70.8	88.5	106	124	142	159	177	
L	10.5	21.0	31.4	41.9	52.4	62.8	73.3	83.8	93.2	105	
T	18.4	36.8	55.2	73.6	92.0	110	129	147	166	184	
L	10.3	20.2	30.3	40.4	50.5	60.6	70.7	80.8	90.9	101	
T	19.2	38.3	57.5	76.7	95.9	115	134	153	172	192	
L	9.8	19.6	29.4	39.2	49.0	58.8	67.6	78.5	87.3	98.1	
T	20	40	60	80	100	120	140	160	180	200	

TABLE IV A-17
SHEET STRETCH
FORMING LIMITS FOR MOLYBDENUM (.5% Ti)
(HOT ROLLED, STRESS RELIEVED, DE-SCALED SHEET)

		Die Radii - R_T Or R_L									
		10	20	30	40	50	60	70	80	90	100
C H O R D L E N G T H	L	8.3	16.7	25.0	33.3	41.7	50.0	58.3	66.7	75.0	83.3
	T	8.3	16.7	25.0	33.3	41.7	50.0	58.3	66.7	75.0	83.3
	L	7.5	15.0	22.6	30.1	37.6	45.1	52.7	60.2	67.7	75.2
	T	9.3	18.5	27.8	37.0	46.3	55.6	64.9	74.1	83.4	92.7
	L	6.9	13.8	20.7	27.6	34.5	41.4	48.3	55.2	62.1	69.0
	T	10.4	20.8	31.3	41.7	52.1	62.5	73.0	83.4	93.8	104
	L	6.2	12.5	18.8	25.0	31.2	37.5	43.8	50.0	56.2	62.5
	T	11.2	22.4	33.5	44.7	55.9	67.0	78.2	89.4	101	112
	L	5.7	11.4	17.1	22.8	28.4	34.1	39.8	45.5	51.2	56.9
	T	12.3	24.7	37.1	49.5	61.8	74.2	86.5	98.9	111	123
	L	5.2	10.4	15.5	20.6	25.8	31.0	36.2	41.3	46.5	51.6
	T	13.5	27.1	40.7	54.2	67.8	81.5	95.0	108	122	135
	L	4.7	9.4	14.1	18.8	23.5	28.2	32.9	37.6	42.3	47.0
	T	14.9	29.9	44.8	59.7	74.7	89.6	105	120	134	149
	L	4.3	8.6	12.8	17.1	21.4	25.7	30.0	34.2	38.5	42.8
	T	16.4	32.8	49.3	65.7	82.0	98.5	115	131	148	164
	L	3.9	7.8	11.6	15.5	19.4	23.3	27.2	31.0	34.9	38.8
	T	18.1	36.3	54.5	72.6	90.7	109	127	145	163	181
L	3.5	7.0	10.5	14.0	17.6	21.1	24.6	28.1	31.6	35.1	
T	20.0	40.0	60.0	80.0	100	120	140	160	180	200	

TABLE IV A-18
SHEET STRETCH
FORMING LIMITS FOR COLUMBIUM (10 Mo-10 Ti)

		Die Radii - R _T Or R _L									
		10	20	30	40	50	60	70	80	90	100
C H O R D L E N G T H	L	7.5	15.1	22.6	30.1	38.6	45.2	52.7	60.2	67.8	75.3
	T	7.5	15.1	22.6	30.1	38.6	45.2	52.7	60.2	67.8	75.3
	L	6.8	13.5	20.3	27.0	33.8	40.6	47.4	54.1	60.8	67.7
	T	8.5	17.0	25.5	34.0	42.5	51.0	59.5	68.0	77.5	85.0
	L	6.1	12.1	18.2	24.2	30.3	36.4	42.5	48.5	54.6	60.7
	T	9.4	18.9	28.3	37.8	47.2	56.6	66.1	75.5	85.0	94.5
	L	5.5	10.9	16.4	21.8	27.3	32.8	38.2	43.7	49.2	50.6
	T	10.5	21.0	31.4	41.9	52.4	62.9	73.4	83.9	94.3	105
	L	4.9	9.8	14.7	19.6	24.6	29.5	34.4	39.3	44.2	49.1
	T	11.6	23.3	34.9	46.5	58.2	69.9	81.5	93.2	105	116
	L	4.4	8.8	13.2	17.6	22.0	26.4	30.8	35.1	39.5	43.9
	T	13.0	26.0	39.0	52.0	65.0	78.0	91.0	104	117	130
L	4.0	7.9	11.9	15.7	19.7	23.7	27.6	31.6	35.6	39.6	
T	14.4	28.9	43.4	57.9	72.3	86.8	101	116	130	144	
L	3.6	7.1	10.6	14.2	17.8	21.3	24.8	27.4	32.0	35.5	
T	16.0	32.1	48.1	64.2	80.2	96.3	112	128	144	160	
L	3.2	6.4	9.6	12.8	16.0	19.2	22.4	25.6	28.8	32.0	
T	17.9	35.8	53.7	71.8	89.5	107	125	143	161	179	
L	2.9	5.7	8.6	11.4	14.3	17.2	20.0	22.9	25.7	28.6	
T	20	40	60	80	100	120	140	160	180	200	

ASD TR 61-191(II)

IV-30

ANDROFORMING

Description of Process

Androforming is a double contour skin forming process. The machine used was the Model J Androform machine located at Convair, Fort Worth, Texas. The results obtained are good for any Androform machine that consists of the following three components: (a) the hold-back system, (b) the shaping system, and (c) the gripper jaws. (See Figure IV B-1).

The leading edge of the sheet is fed between the elements in "a" and "b" and clamped in "c". The elements at "a" and "b" are then closed to predetermined gaps and the sheet pulled between them as "c" moves as shown. The elements at "a" are straight; i.e., they have no transverse curvature, while the elements at "b" and "c" are set to a given curvature (the element radius) before forming begins. The edges, represented by the distance "x - x", change little during forming but the center longitudinal element stretches to the length "y - y". It is this difference between the stretch at the center and the edge of the sheet that causes the contour in the transverse as well as the longitudinal direction. There is another factor which contributes to contour. The center longitudinal element, having stretched more than the edges, has a greater amount of springback, thus adding to the double contour.

The machine adjustments are represented by the dimensions in Figure IV B-2. Changing the "A" dimension has by far the greatest effect on the severity of double contouring of any of the machine adjustments. Other adjustments should be set at optimum conditions for each gage and the "A" dimension varied for different contours desired.

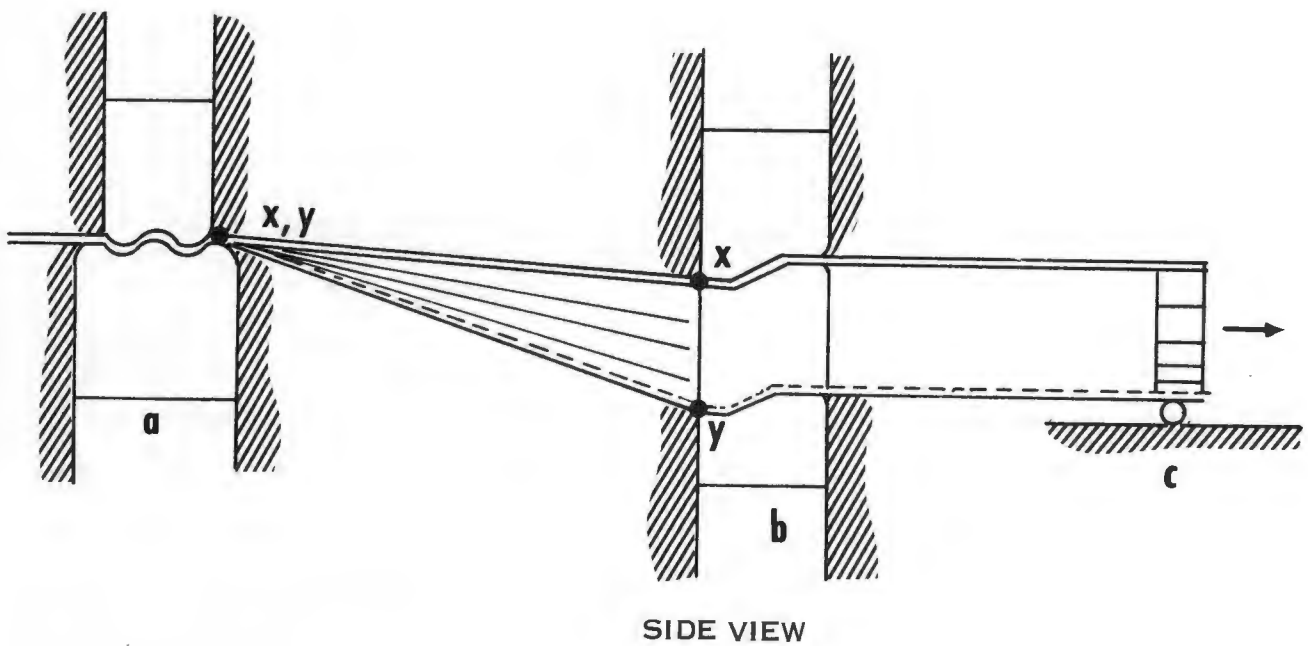
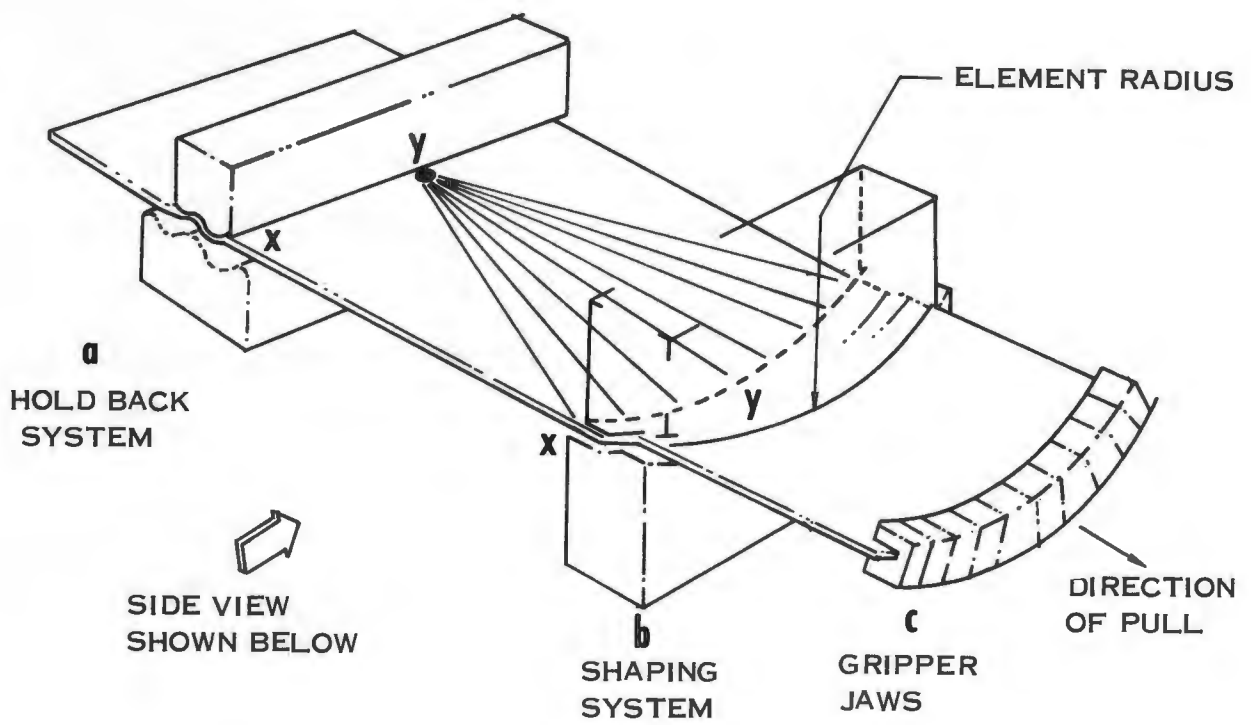

FIGURE IV B-1 ANDROFORM COMPONENTS

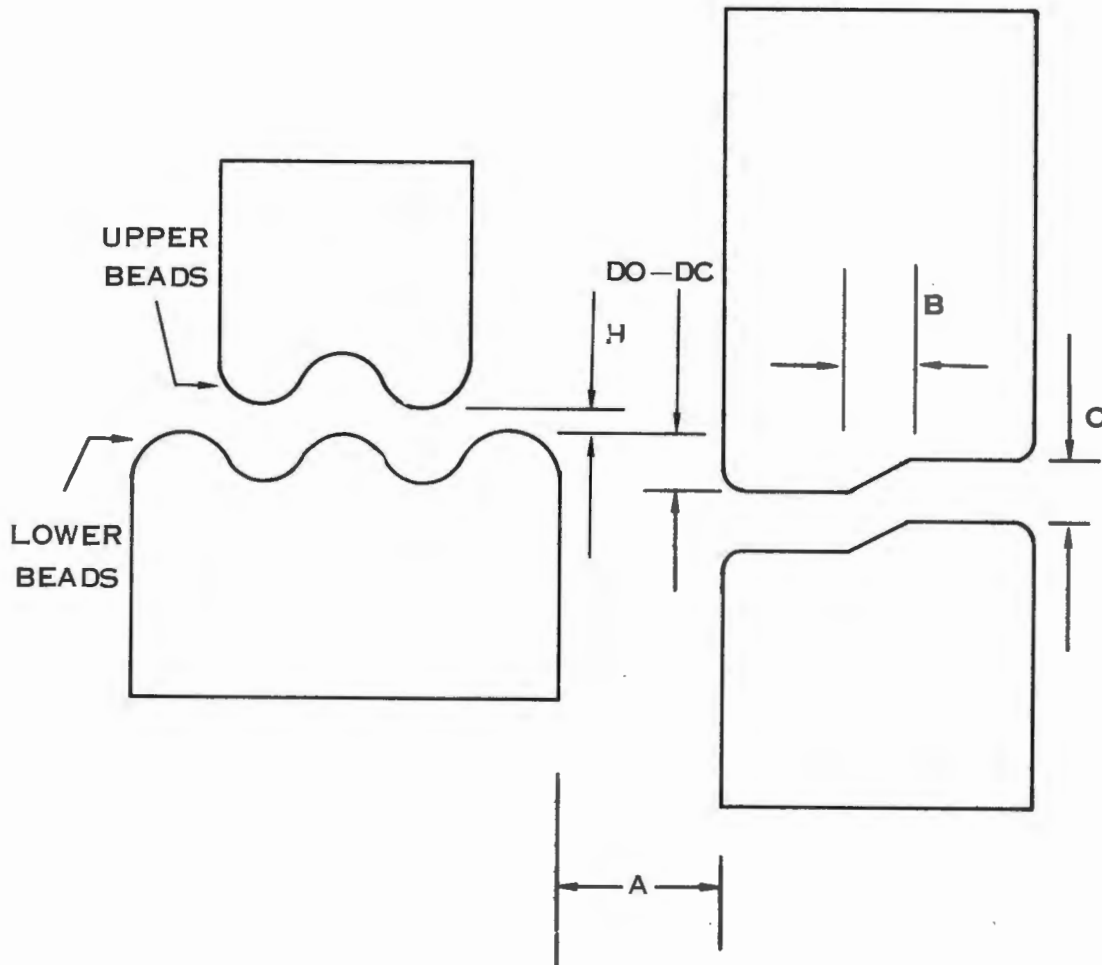

FIGURE IV B-2 MACHINE ADJUSTMENTS FOR ANDROFORMING

By using the large shaping element radius (100" and above) no limit could be reached; however, the resulting compound radius was very high. Smaller contour radii were obtained by using 50" and 20" forming elements and the splitting and buckling limits were obtained.

Definition of Part Shape
and Geometric Variables

The geometric variables of double contoured androformed parts are illustrated in Figure IV B-3.

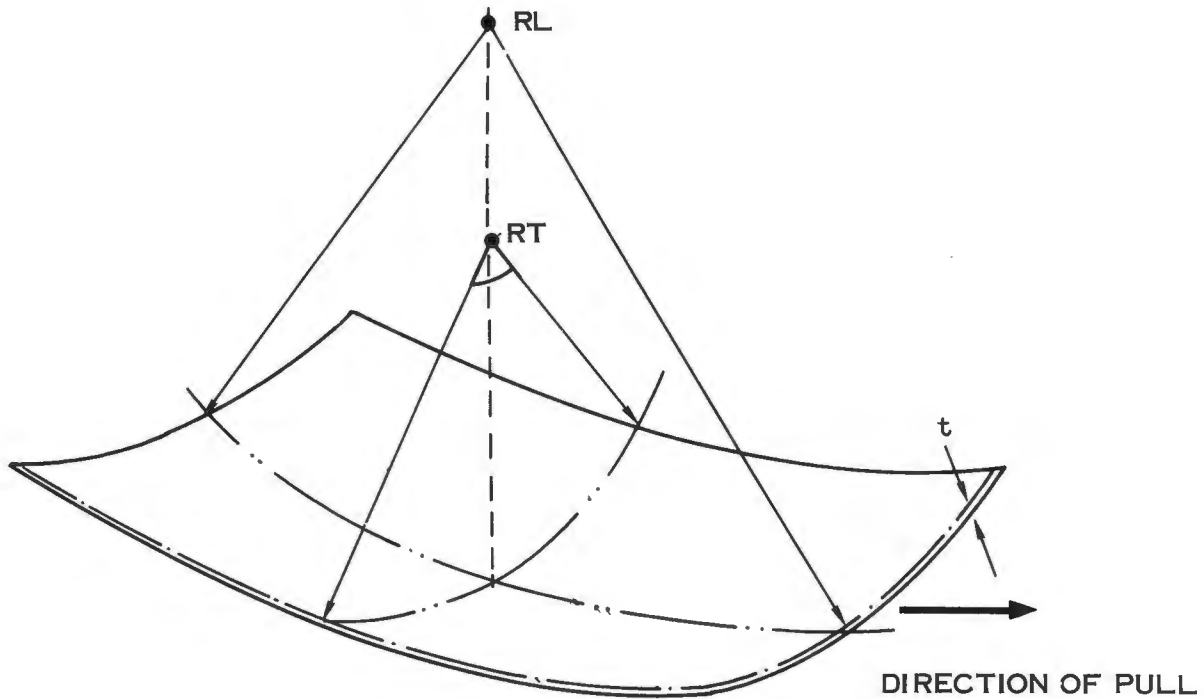

FIGURE IV B-3 GEOMETRIC VARIABLES FOR ANDROFORMING

R_L and R_T are the longitudinal and transverse radii, respectively. By adjusting the machine settings these radii can be reduced down to the limit. For a particular formed part if R_L is forced to a large radius, R_T will be reduced to a smaller radius proportionately, i.e., R_T/R_L is equal to a constant.

Splitting or buckling will occur if the radii are made too small. By increasing the thickness, buckling is reduced; however, the possibility of splitting increases.

Predictability Equations

The following predictability equations were developed for the 20 inch and 50 inch forming element radius.

The equations for the splitting limits of any material based upon its mechanical properties are:

For 50 inch forming die:

$$\frac{R_T}{\sqrt{t}} = 41 \left[\frac{E}{\epsilon_{2.0} S_{TY}} \right] \left[\frac{R_L}{\sqrt{t}} \right]^{-1}$$

Equation I

For 20 inch forming die:

$$\frac{R_T}{\sqrt{t}} = 5.0 \left[\frac{E}{\epsilon_{2.0} S_{TY}} \right] \left[\frac{R_L}{\sqrt{t}} \right]^{-1}$$

Equation II

The equations for the buckling limits of any material based upon its mechanical properties are:

For 50 inch forming die:

$$R_T t = \left[2.51 \times 10^{-6} \right] \left[\frac{S_{TY}}{E} \right]^{-2.7} \left[R_L t \right]^{-1}$$

Equation III

For 20 inch forming die:

$$R_T t = 1.471 \times 10^{-6} \left[\frac{S_{TY}}{E} \right]^{-2.7} \left[R_L t \right]^{-1}$$

Equation IV

To use Equations I through IV the mechanical properties of the material must be known along with two of the three geometric variables. The problem is to find the smallest R_L that can be formed without splitting or buckling for a particular R_T and t .

As an example utilizing the 50 inch die limits; solve Equation I and III for R_L .

$$R_L = 41\sqrt{t} \left[\frac{E}{\epsilon_{2.0} S_{TY}} \right] \left[\frac{R_T}{\sqrt{t}} \right]^{-1}$$

Equation I-a

$$R_L = \left[\frac{2.51 \times 10^{-6}}{t} \right] \left[\frac{S_{TY}}{E} \right]^{-2.7} \left[R_T t \right]^{-1}$$

Equation III-a

The actual forming limit for R_L is the largest value obtained from either Equation (I-a) or (III-a). Values of R_L smaller than that found by Equation (I-a) will split while values of R_L smaller than that found by Equation (III-a) will buckle.

An alternate, and somewhat simpler, method of finding the formability limits is to construct the curves as defined by Equations I and III. Typical theoretical formability limit curves for splitting and buckling are shown in Figures IV B-4 and IV B-5.

Knowing the mechanical properties that are included in Equations I and III the formability limit graphs can be constructed as follows:

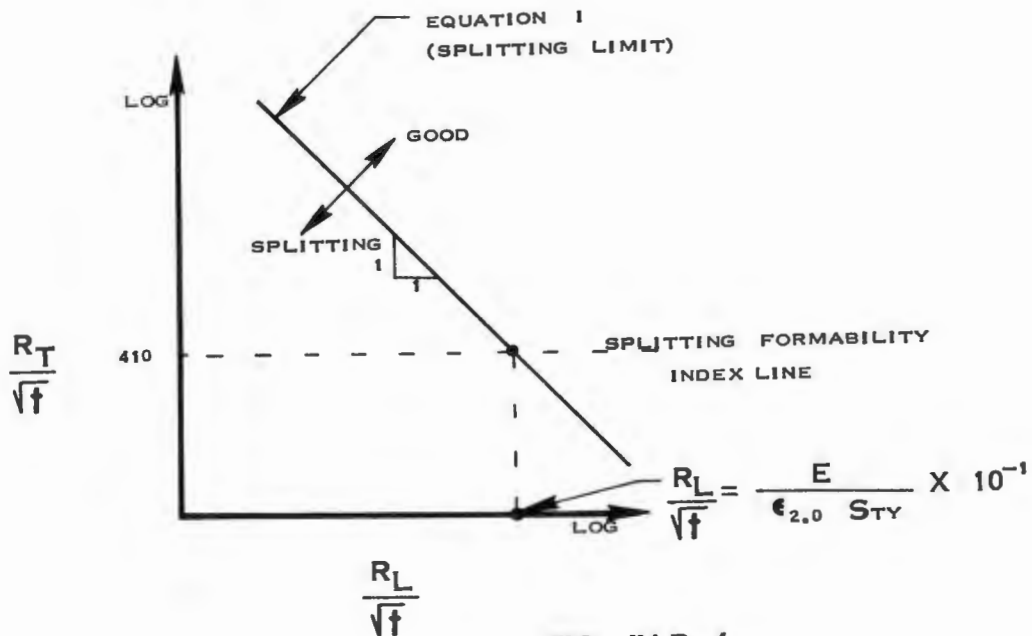

FIG. IV B-4
SPLITTING LIMIT CURVE

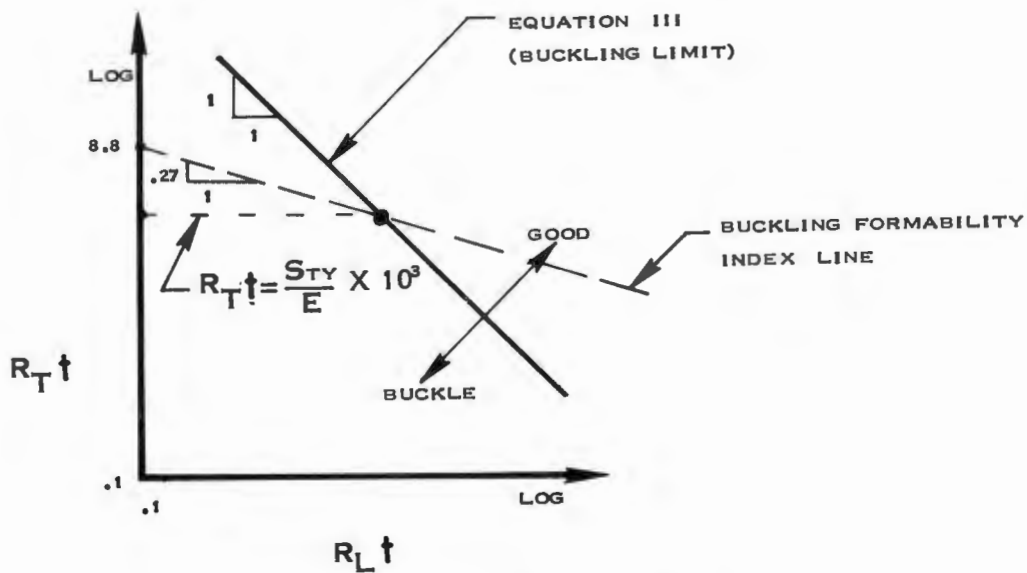

FIG. IV B-5
BUCKLING LIMIT CURVE

Splitting

Step I: Using log-log graph paper and plotting $\frac{R_T}{\sqrt{t}}$ on the ordinate and $\frac{R_L}{\sqrt{t}}$ on the abscissa, construct the formability index line at a constant $\frac{R_T}{\sqrt{t}}$ of 410. See Figure IV B-4.

Step II: From the mechanical properties of the material as defined by the standard tensile specimen, calculate the splitting index.

$\text{SPLITTING INDEX} = \frac{E}{\epsilon_{2.0} S_{TY}}$	Equation V
--	------------

Step III: At the intersection of $\frac{R_L}{\sqrt{t}} = \frac{E}{\epsilon_{2.0} S_{TY}} \times 10^{-1}$ and $\frac{R_T}{\sqrt{t}} = 410$ plot the limiting curve with a slope of minus one (-1). See Figure IV B-4.

Step IV: Knowing a particular R_T and t (R_T' , t'), the splitting limit R_L' can be determined as follows:

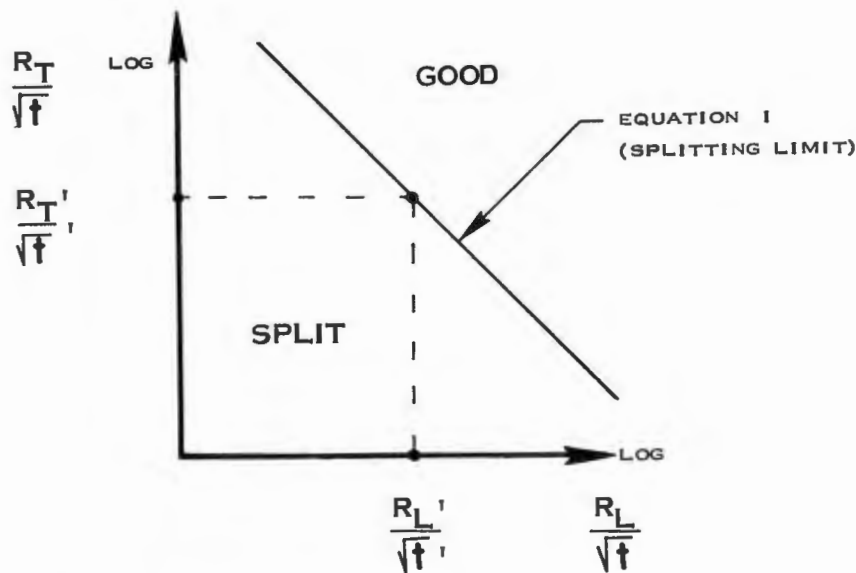

FIGURE IV B-6 PROCEDURE FOR FINDING THE SPLITTING LIMIT

The value of $\frac{R_T}{\sqrt{t}}$ is plotted horizontally until it intersects the splitting limit curve. From this intersection a line is drawn vertically to the $\frac{R_L}{\sqrt{t}}$ axis. The value of $\frac{R_L}{\sqrt{t}}$ is read directly.

SPLITTING LIMIT $R_L' = \left[\frac{R_L'}{\sqrt{t'}} \right] \times \sqrt{t'}$	Equation IV
--	-------------

Buckling

Step I: Using log-log graph paper and plotting $R_T t$ on the ordinate and $R_L t$ on the abscissa, construct the buckling formability index line with a slope of - 0.27 intersecting the $R_T t$ axis at 8.8 at an $R_L t$ of 0.1. See Figure IV B-5.

Step II: From the mechanical properties of the material as defined by the standard tensile specimen, calculate the buckling index.

BUCKLING INDEX = $\frac{S_{TY}}{E}$	Equation V
--	------------

Step III: At the intersection of $R_T t = \frac{S_{TY}}{E} \times 10^3$ and the buckling index line plot the limiting curve with a slope of minus one (- 1). See Figure IV B-5.

Step IV: Knowing the particular R_T and t (R_T' , t'), the buckling limit R_L'' can be determined as follows:

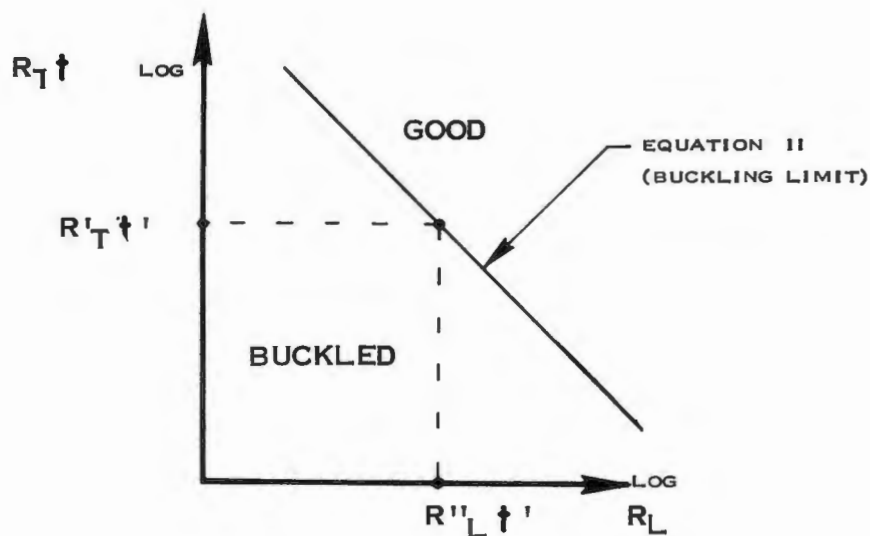

FIGURE IV B-7 PROCEDURE FOR FINDING THE BUCKLING LIMIT

The value of $R_T t'$ is plotted horizontally until it intersects the buckling limit curve. From this intersection a line is drawn vertically to the $R_L t'$ axis. The limiting value of $R_L'' t'$ is read directly.

Buckling Limit $R_L'' = \left[R_L'' t' \right] \frac{1}{t'}$	Equation VI
---	-------------

If R_L'' is greater than R_L' , the actual limit is defined by R_L , i.e. any value of R_L less than R_L'' will cause buckling. If R_L' is greater than R_L'' , the actual limit is defined by R_L' , i.e. any value of R_L less than R_L' will cause splitting.

Composite Graphs

Composite graphs were constructed for the 20 inch and 50 inch radius forming elements. The splitting and buckling limit composites for the 50 inch and 20 inch dies are in Graphs V B-1 through V B-4 respectively.

An alternate method of plotting the limits for each material is illustrated in Graph IV B-5. The R_L limit can be read directly from the curve by selecting R_T and t . Buckling limits are shown in solid lines and splitting limits in dashed lines.

By using a larger forming element radius the resulting double contour would have larger radii. Preliminary investigations revealed that actual limits could not be reached by using the large radius form dies.

GRAPH IV B-1
COMPOSITE GRAPH FOR ANDROFORM SPLITTING LIMITS FOR
(50" FORMING ELEMENT)

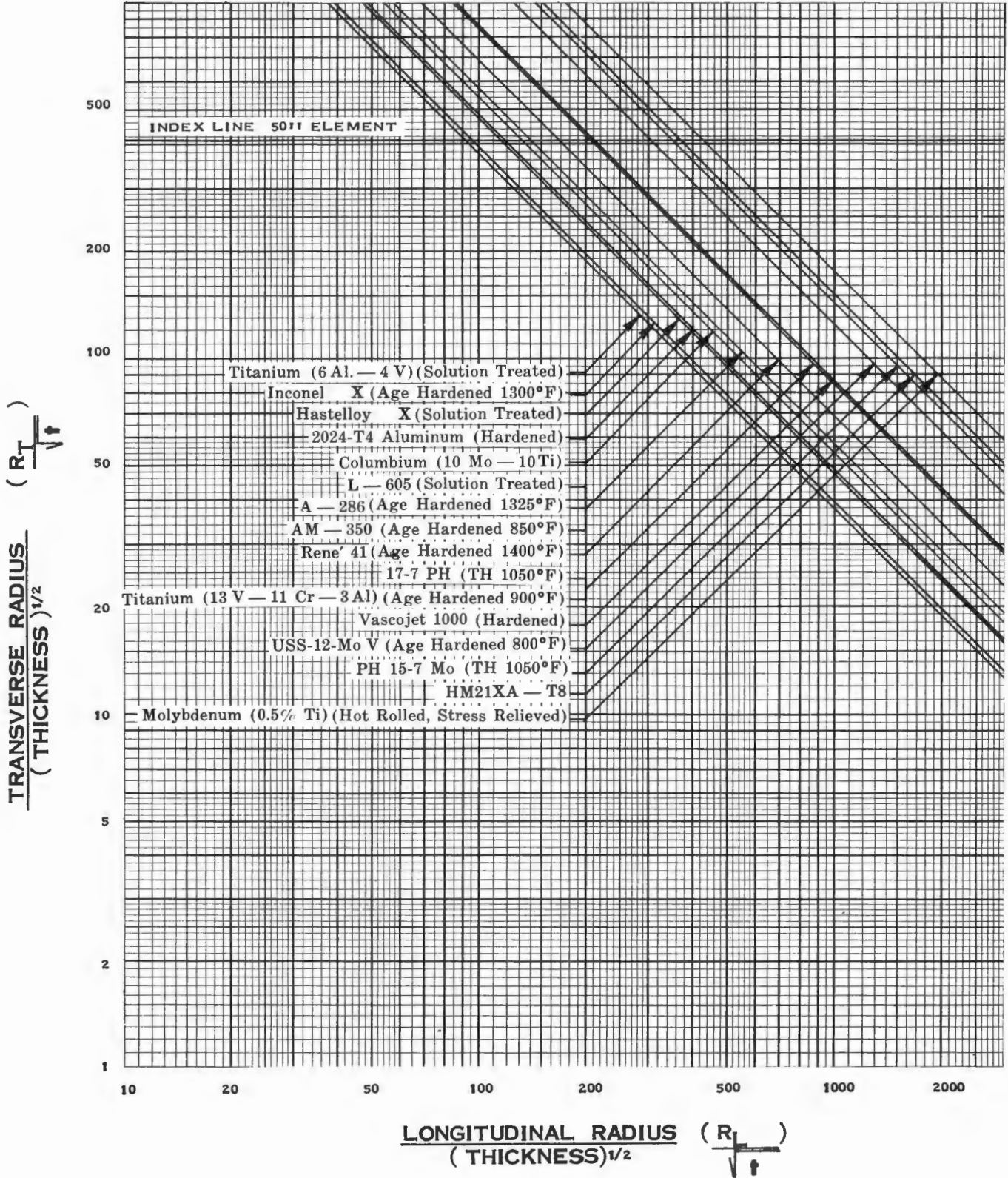

GRAPH IV B-2
COMPOSITE GRAPH FOR ANDROFORM BUCKLING LIMITS FOR
(50" FORMING ELEMENT)

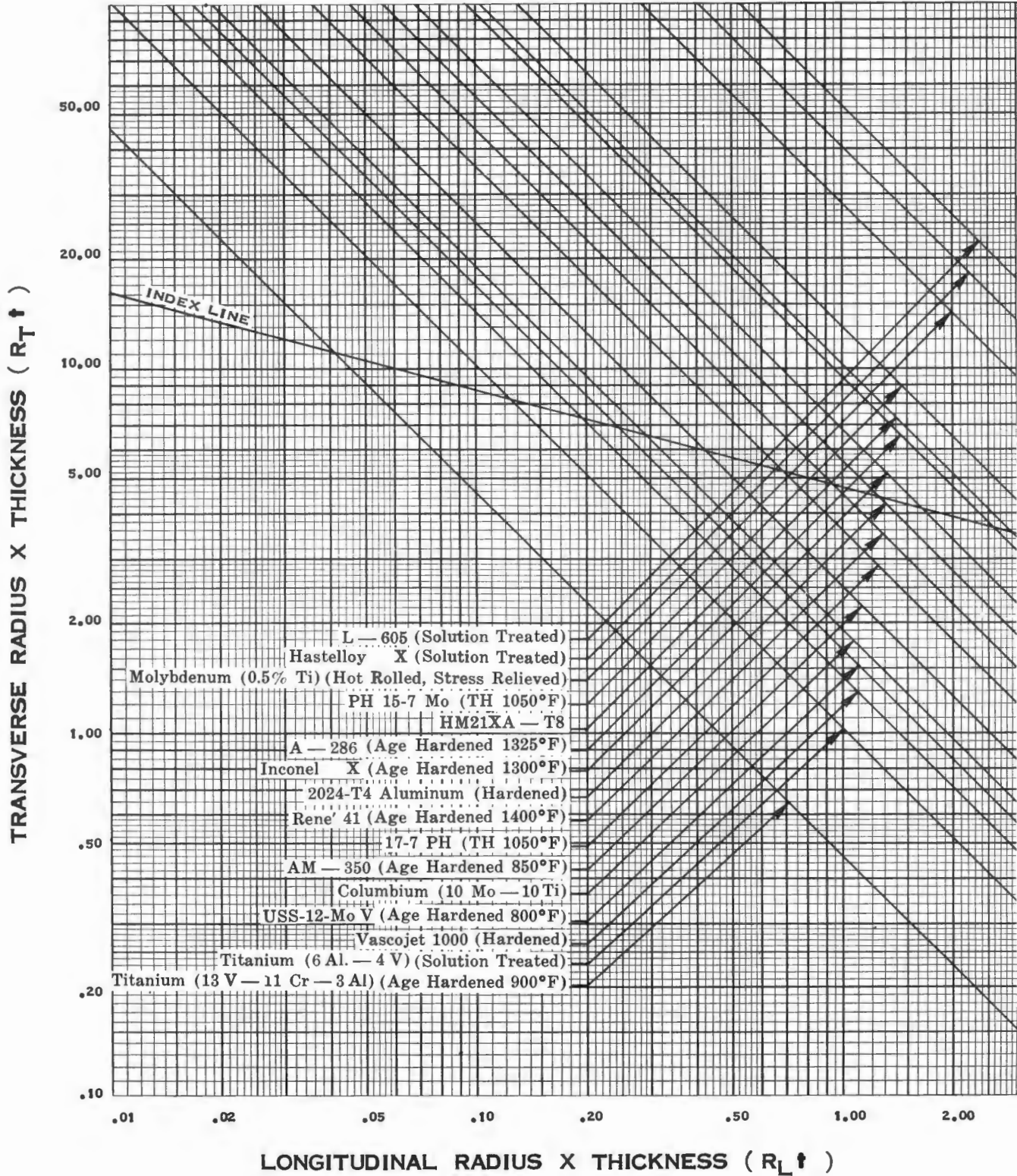

GRAPH IV B-3
COMPOSITE GRAPH FOR ANDROFORM SPLITTING LIMITS FOR
(20" FORMING ELEMENT)

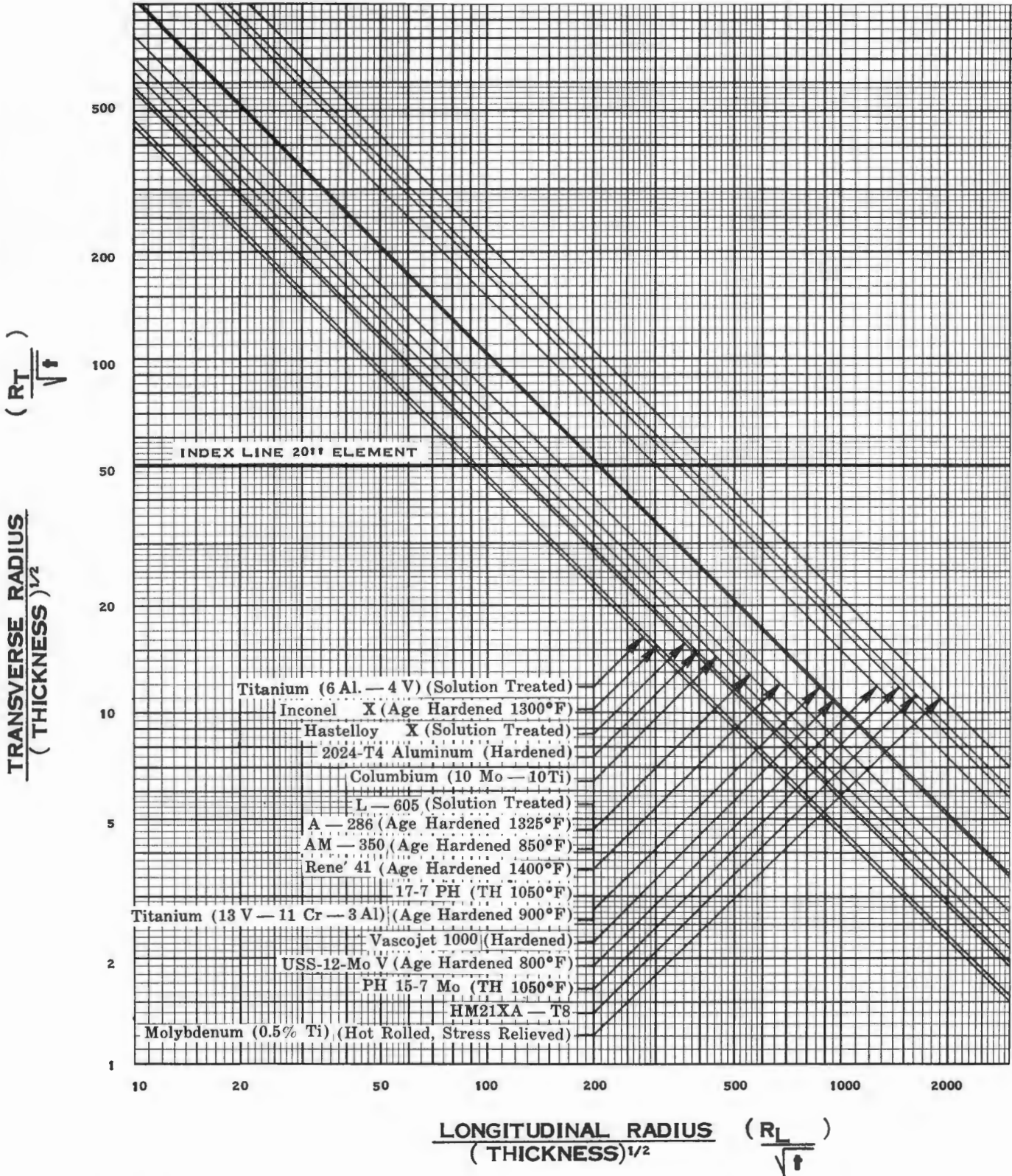

GRAPH IV B-4
COMPOSITE GRAPH FOR ANDROFORM BUCKLING LIMITS FOR
(20" FORMING ELEMENT)

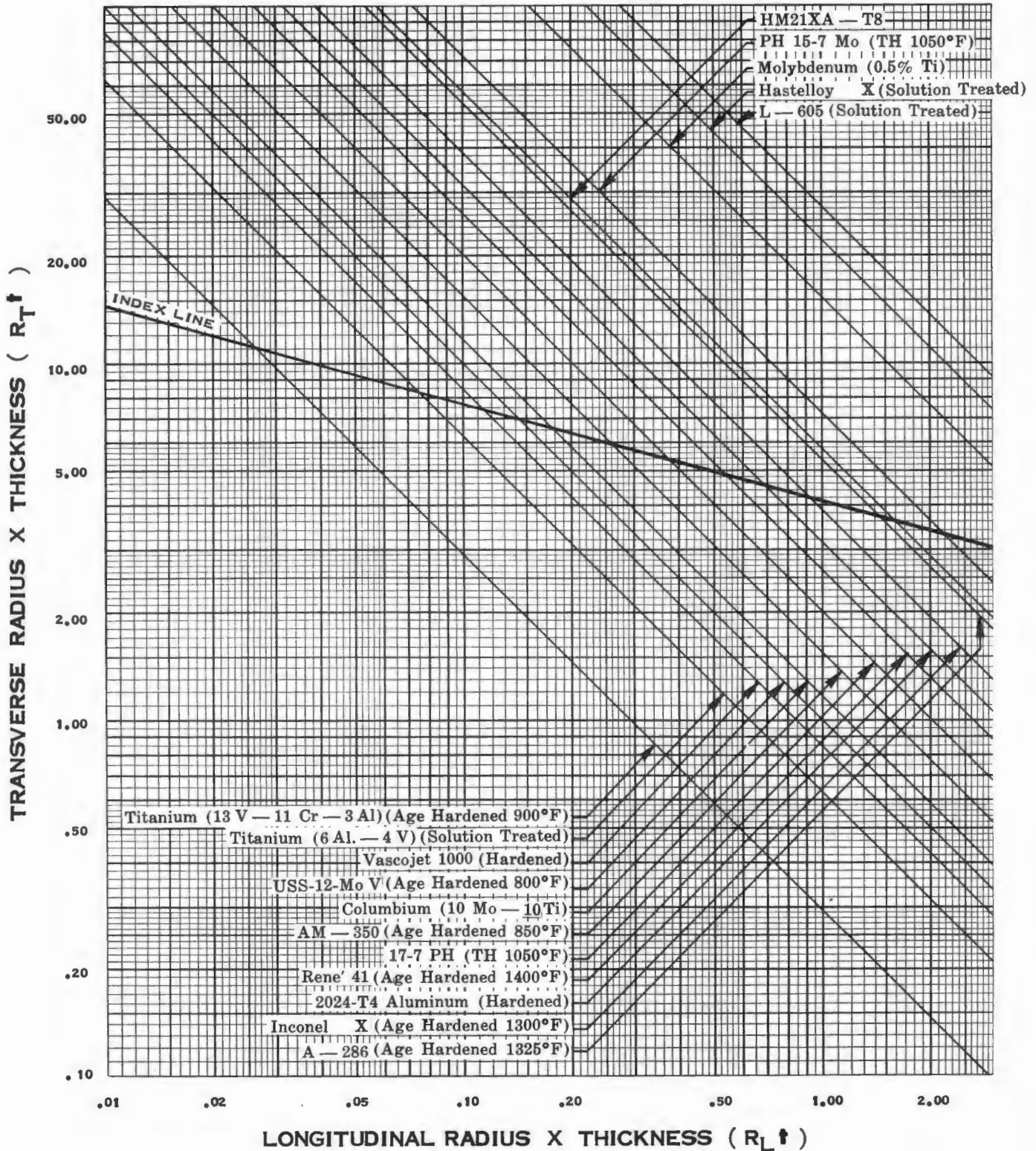

GRAPH IV B-5
ALTERNATE METHOD OF PLOTTING ANDROFORM
LIMITS (2024-T4 ALUMINUM)

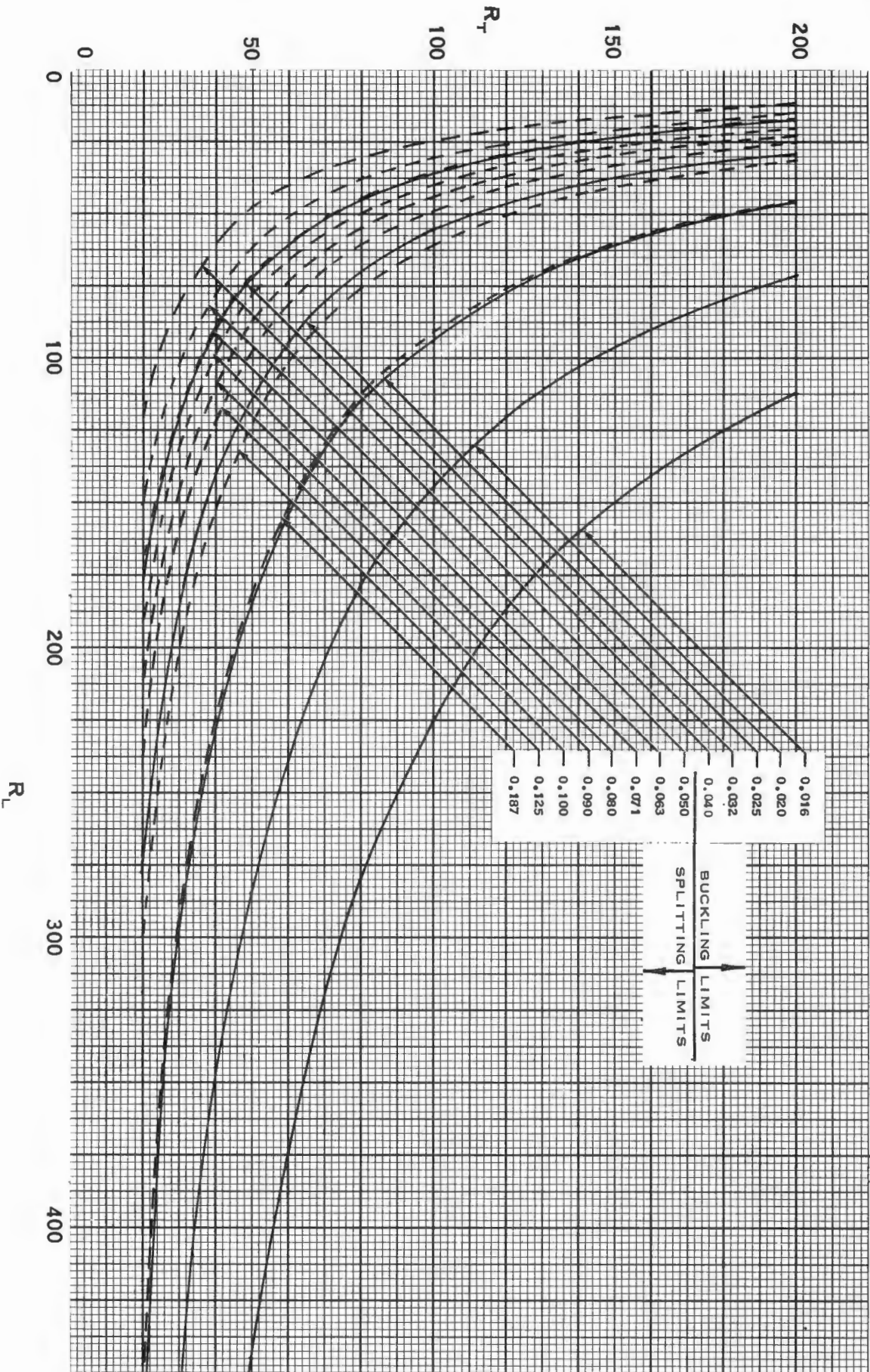

Design Tables

Design tables for all materials for the 50 inch forming die have been established with the exception of tungsten, beryllium and J-1570. Tungsten and beryllium have to be formed at elevated temperatures. Mechanical property values for J-1570 in the heat treated condition were not obtained. Design tables are in Tables IV B-1 through IV B-16.

Knowing R_T and t , the minimum R_L can be read directly from the table. Splitting and buckling failure is designated on the table.

TABLE IV B-1
 ANDROFORM LIMITS
 HM21XA-T8 (MAGNESIUM-THORIUM)

Trans. Radius (R_T)	Material Thickness (t)												
	.016	.020	.025	.032	.040	.050	.063	.071	.080	.090	.100	.125	.187
	Longitudinal Radius (R_L)												
	BUCKLING						SPLITTING						
20	2060	1310	848	518	330	380	479	538	608	645	727	954	1427
30	1380	885	568	344	216	250	316	357	399	423	474	636	952
40	1040	662	420	253	162	189	237	265	300	318	354	474	714
50	825	525	326	203	135	158	188	213	242	256	283	375	562
60	688	430	276	170	108	126	157	178	201	213	237	316	458
80	506	325	208	127	82	94	119	133	150	159	178	237	350
100	406	260	166	101	65	75	95	107	120	127	142	187	281
120	341	217	139	85	54	62	79	89	100	106	118	156	234
140	291	107	118	75	47	53	68	76	85	91	100	134	201
160	253	163	104	64	41	47	60	67	75	80	88	118	177
180	220	145	92	57	36	42	53	59	68	72	79	104	158
200	206	130	83	51	33	38	47	53	60	64	71	94	140

ASD TR 61-191(II)

IV-48

Table - IV B-2
 ANDROFORM LIMITS
 2024-T4 ALUMINUM

ASD TR 61-191(II)

IV-49

Trans. Radius (R _T)	Material Thickness (t)												
	.016	.020	.025	.032	.040	.050	.063	.071	.080	.090	.100	.125	.187
	Longitudinal Radius (R _L)												
	Buckling					Splitting							
20	1110	700	460	278	177	120	151	169	191	212	237	297	445
30	745	475	302	188	120	81	102	115	129	146	158	198	298
40	555	350	230	141	90	60	77	86	97	110	122	152	220
50	445	285	184	113	72	48	61	68	77	87	98	121	182
60	375	240	153	94	60	40	51	57	65	73	81	101	151
80	281	178	115	70	45	30	38	43	49	54	60	76	112
100	225	144	92	56	36	24	31	35	39	44	49	60	90
120	187	120	76	47	30	20	26	29	32	37	40	51	75
140	160	103	66	40	26	17	22	25	28	31	35	43	65
160	141	90	58	35	22	15	19	22	24	27	30	38	57
180	125	80	51	31	20	14	17	19	22	24	27	34	51
200	112	72	46	28	18	12	15	17	20	22	24	30	46

TABLE IV B-3
ANDROFORM LIMITS
17-7 PH (STAINLESS STEEL)
(CONDITION TH 1050)

Trans. Radius (R_T)	Material Thickness (t)													
	.016	.020	.025	.032	.040	.050	.063	.071	.080	.090	.100	.125	.187	
	Longitudinal Radius (R_L)													
	BUCKLING				SPLITTING									
20	695	445	284	181	173	219	276	314	348	393	471	559	822	
30	469	300	190	117	116	140	184	208	232	260	291	364	541	
40	350	222	142	88	87	110	138	154	174	198	220	276	406	
50	278	178	114	70	70	92	110	125	140	156	174	217	326	
60	232	149	95	58	58	73	92	104	117	131	146	184	266	
80	172	111	72	44	44	55	69	78	88	98	109	138	204	
100	139	90	57	35	35	44	55	62	70	79	88	110	164	
120	116	75	48	29	29	37	46	52	58	65	74	91	136	
140	95	64	41	25	25	31	40	44	50	56	63	78	117	
160	87	56	36	22	22	28	35	39	44	49	55	68	102	
180	78	50	32	20	20	24	31	35	39	44	49	61	92	
200	70	45	29	18	18	21	28	31	35	39	44	55	82	

TABLE IVB-4
 ANDROFORM LIMITS
 PH 15-7 Mo (STAINLESS STEEL)
 (CONDITION TH 1050)

Trans. Radius (R _T)	Material Thickness (t)												
	.016	.020	.025	.032	.040	.050	.063	.071	.080	.090	.100	.125	.187
	Longitudinal Radius (R _L)												
	BUCKLING						SPLITTING						
20							674	521	571	642	720	890	
30						700	448	350	384	432	480	600	920
40				829	530	330	263	285	324	363	451	656	
50				662	422	268	210	232	261	288	357	540	
60				862	550	356	224	176	192	216	240	302	450
80				650	418	264	165	132	144	162	180	226	336
100			848	522	333	214	134	106	116	130	145	180	268
120			711	432	275	177	112	88	92	108	121	151	228
140		950	607	369	238	152	95	77	83	93	99	129	191
160		835	527	325	208	133	83	66	73	82	90	113	169
180		740	471	290	185	118	75	59	65	73	81	100	151
200		660	424	260	165	106	67	53	57	64	72	89	133

ASD TR 61-191(II)

IV-51

TABLE IVB-5
 ANDROFORM LIMITS
 AM-350 (STAINLESS STEEL)
 (AGE HARDENED AT 850°F)

Material Thickness (t)														
Trans. Radius (RT)	.016	.020	.025	.032	.040	.050	.063	.071	.080	.090	.100	.125	.187	
	Longitudinal Radius (RL)													
	BUCKLING				SPLITTING									
20	494	320	204	125	114	143	181	200	226	252	288	353	522	
30	331	211	135	82	78	94	120	133	148	171	191	238	354	
40	250	159	101	62	57	72	90	101	113	127	144	176	264	
50	199	126	81	49	46	58	73	81	92	104	115	141	214	
60	162	110	68	41	38	48	60	67	77	86	96	120	179	
80	125	79	51	31	29	36	45	51	57	64	72	89	134	
100	99	63	41	25	23	29	36	41	46	52	58	71	108	
120	82	52	34	21	19	24	31	34	38	43	48	60	90	
140	71	45	29	18	16	21	26	29	33	37	41	52	77	
160	62	40	26	16	14	18	23	25	29	32	36	45	67	
180	55	35	23	14	13	16	20	23	26	29	32	40	60	
200	49	31	20	12	11	14	18	20	23	25	29	35	52	

ASD TR 61-191(II)

IV-52

TABLE IVB-6
 ANDROFORM LIMITS
 A-286 (STAINLESS STEEL)
 (AGE HARDENED AT 1325°F)

Trans. Radius (R _T)	Material Thickness (t)												
	.016	.020	.025	.032	.040	.050	.063	.071	.080	.090	.100	.125	.187
	Longitudinal Radius (R _L)												
	BUCKLING						SPLITTING						
20			760	469	300	190	181	200	226	252	288	353	522
30		800	511	313	198	126	120	133	148	171	191	238	354
40	938	600	380	203	149	95	90	101	113	127	144	176	264
50	750	475	302	186	119	76	73	81	92	104	115	141	214
60	625	395	252	153	99	64	60	67	77	86	96	120	179
80	469	298	180	116	80	48	45	51	57	64	72	89	134
100	372	236	152	87	60	38	36	41	46	52	58	71	108
120	309	199	128	77	50	32	31	34	38	43	48	60	90
140	265	170	109	67	42	28	26	29	33	37	41	52	77
160	232	150	96	59	37	24	23	25	29	32	36	45	67
180	208	132	85	52	33	22	20	23	26	29	32	40	60
200	188	119	76	47	30	19	18	20	23	25	29	35	52

ASD TR 61-191(II)

IV-53

TABLE IV B-7
 ANDROFORM LIMITS
 USS-12-MoV (STAINLESS STEEL)
 (AGE HARDENED AT 800°F)

Trans. Radius (R _T)	Material Thickness (t)												
	.016	.020	.025	.032	.040	.050	.063	.071	.080	.090	.100	.125	.187
	Longitudinal Radius (R _L)												
	BUCKLING			SPLITTING									
20	333	215	155	200	246	313	392	440	495	564	626	778	1168
30	220	139	104	132	165	208	264	298	328	369	411	516	778
40	166	106	77	104	124	155	196	220	247	279	310	396	584
50	133	84	62	80	99	130	156	176	195	222	248	309	467
60	111	71	52	66	82	104	129	146	165	186	207	262	278
80	83	53	38	50	62	77	98	110	124	139	154	233	290
100	66	43	31	40	50	62	78	88	99	112	124	155	246
120	56	36	26	33	41	51	65	73	82	93	104	129	190
140	48	30	22	28	35	44	56	63	71	79	88	110	165
160	42	27	19	25	31	37	49	55	62	69	77	96	144
180	37	24	17	21	28	34	41	49	55	62	69	86	130
200	33	21	16	20	25	31	39	44	49	55	62	77	115

ASD TR 61-191(II)

IV-54

TABLE IV B-8
 ANDROFORM LIMITS
 TITANIUM (6Al-4V)
 (SOLUTION TREATED)

Trans. Radius (R_T)	Material Thickness (t)												
	.016	.020	.025	.032	.040	.050	.063	.071	.080	.090	.100	.125	.187
	Longitudinal Radius (R_L)												
	BUCKLING			SPLITTING									
20	200	130	82	60	74	92	118	133	148	165	187	231	298
30	132	85	55	40	50	62	80	90	100	112	125	156	233
40	102	65	41	30	37	47	60	67	75	84	97	118	174
50	81	51	33	24	30	38	47	53	60	68	76	93	140
60	67	42	28	20	25	31	40	45	50	56	63	78	118
80	51	32	20	13	19	23	30	33	37	42	47	59	87
100	40	26	17	12	15	19	24	27	30	34	38	47	70
120	33	22	14	10	13	16	20	22	25	28	31	40	58
140	30	18	12	8.6	11	13	17	19	21	24	27	34	50
160	25	16	10	7.4	9.4	12	15	17	19	21	23	29	44
180	22	14	9.2	6.4	8.4	10	13	15	17	19	21	26	39
200	20	13	8.2	6.0	7.5	9.5	12	13	15	17	19	23	35

ASD TR 61-191(II)

IV-55

TABLE IV B-9
 ANDROFORM LIMITS
 TITANIUM (13V-11Cr-3Al)
 (AGE HARDENED 900°F)

Trans. Radius (R _T)	Material Thickness (t)												
	.016	.020	.025	.032	.040	.050	.063	.071	.080	.090	.100	.125	.187
	Longitudinal Radius (R _L)												
	BUCKLING						SPLITTING						
20	88	83	106	132	164	208	261	296	334	370	418	523	769
30	59	55	70	90	112	139	175	194	223	249	275	346	518
40	45	42	50	66	83	104	131	147	167	187	209	258	389
50	36	33	42	53	67	83	105	118	134	150	165	206	309
60	30	28	37	45	56	69	88	99	110	125	138	173	259
80	22	21	27	34	44	53	66	74	83	93	104	129	194
100	18	17	21	27	34	42	53	59	67	75	84	104	155
120	15	14	18	23	28	35	44	49	55	63	70	88	130
140	13	12	15	19	24	30	38	43	48	54	60	76	110
160	11	10	13	17	21	26	33	37	42	44	52	64	97
180	9.9	9.5	12	15	19	23	30	33	37	42	47	58	87
200	8.9	9.0	11	14	17	21	26	30	34	38	42	52	78

TABLE IV B-10
 ANDROFORM LIMITS
 VASCOJET 1000 (H-11)
 (HARDENED)

Trans. Radius (R _T)	Material Thickness (t)												
	.016	.020	.025	.032	.040	.050	.063	.071	.080	.090	.100	.125	.187
	Longitudinal Radius (R _L)												
	BUCKLING		SPLITTING										
20	277	178	113	145	180	224	286	322	365	414	481	573	865
30	185	123	75	96	120	143	191	216	242	270	304	375	562
40	139	89	56	76	90	114	144	160	181	204	226	286	426
50	110	71	45	58	72	95	114	128	144	161	180	226	340
60	93	59	38	49	60	76	95	107	121	135	150	190	277
80	70	45	28	36	45	57	71	80	91	102	112	141	212
100	56	36	23	29	36	46	58	64	72	82	90	114	170
120	47	30	19	24	30	38	48	53	60	68	76	94	140
140	40	26	17	21	26	33	41	46	52	58	64	81	121
160	35	23	14	18	23	29	36	40	46	51	56	71	106
180	32	20	13	15	20	25	32	36	41	45	51	63	95
200	28	18	11	15	18	23	29	32	36	41	46	57	85

ASD TR 61-191(II)

IV-57

TABLE IV B-11
ANDROFORM LIMITS
RENE '41
(AGE HARDENED AT 1400 °F)

Trans. Radius (R_T)	Material Thickness (t)												
	.016	.020	.025	.032	.040	.050	.063	.071	.080	.090	.100	.125	.187
	Longitudinal Radius (R_L)												
	BUCKLING						SPLITTING						
20	881	570	364	224	141	168	216	240	272	303	342	424	632
30	594	375	240	147	94	113	148	161	181	204	228	284	433
40	443	281	180	111	71	86	108	120	136	151	171	208	320
50	350	225	144	88	57	68	87	97	110	123	136	170	255
60	294	187	120	74	47	58	73	80	88	102	114	143	218
80	220	142	90	56	35	43	55	61	68	78	86	107	160
100	176	113	73	44	28	34	44	48	55	61	69	85	127
120	147	94	60	37	24	29	37	41	45	51	57	71	108
140	126	81	52	32	20	25	32	35	40	43	49	62	91
160	111	71	45	28	18	21	27	31	35	39	43	54	80
180	99	64	40	25	16	19	25	28	31	34	38	48	72
200	88	57	36	22	14	17	22	24	27	30	34	42	63

TABLE IV B-12
 ANDROFORM LIMITS
 INCONEL X
 (AGE HARDENED AT 1300 °F)

Material Thickness (t)													
Trans. Radius (R _T)	.016	.020	.025	.032	.040	.050	.063	.071	.080	.090	.100	.125	.187
	Longitudinal Radius (R _L)												
	BUCKLING						SPLITTING						
20	1330	850	543	331	212	136	124	138	157	177	196	248	365
30	880	565	360	222	142	91	82	92	103	117	130	163	246
40	650	425	272	166	107	68	61	69	77	88	97	121	184
50	528	340	218	133	85	54	49	55	62	70	78	96	145
60	444	285	180	111	72	46	41	46	52	58	65	82	121
80	331	212	136	84	54	34	31	35	39	44	49	61	92
100	266	170	109	67	43	28	25	28	31	35	39	48	73
120	222	142	91	56	35	22	21	23	26	29	32	41	61
140	190	122	78	47	30	19	18	19	22	25	28	34	52
160	167	107	68	42	27	17	16	17	20	22	25	31	46
180	149	95	61	37	24	15	14	16	18	20	22	28	41
200	134	85	55	33	21	14	12	14	16	18	20	24	37

ASD TR 61-191(II)

IV-59

TABLE IVB-13
 ANDROFORM LIMITS
 HASTELLOY X
 (SOLUTION TREATED)

Trans. Radius (R _T)	Material Thickness (t)												
	.016	.020	.025	.032	.040	.050	.063	.071	.080	.090	.100	.125	.187
	Longitudinal Radius (R _L)												
	BUCKLING							SPLITTING					
20					895	572	357	286	225	200	237	294	441
30				932	600	384	231	190	150	140	158	194	292
40				704	450	288	178	142	111	104	118	147	217
50			912	562	350	230	144	114	89	85	95	117	174
60			760	465	300	190	120	94	75	70	79	99	149
80		900	568	350	222	142	89	71	56	56	59	73	110
100		720	456	280	178	114	72	57	45	43	47	59	87
120	935	600	380	232	149	95	60	47	37	35	39	49	73
140	800	510	324	204	129	81	52	41	32	30	33	42	63
160	700	445	284	176	111	71	45	35	28	27	29	36	55
180	625	395	256	155	99	63	41	31	25	24	26	32	50
200	563	355	228	141	90	57	36	29	22	20	24	29	44

ASD TR 61-191(II)

IV-60

TABLE IVB-14
 ANDROFORM LIMITS
 L-605
 (SOLUTION TREATED)

Trans. Radius (R _T)	Material Thickness (t)												
	.016	.020	.025	.032	.040	.050	.063	.071	.080	.090	.100	.125	.187
	Longitudinal Radius (R _L)												
	BUCKLING						SPLITTING						
20				641	413	264	181	200	226	252	288	353	522
30			700	426	275	174	120	133	148	171	191	238	354
40		825	528	325	205	130	90	101	113	127	144	176	264
50		660	420	254	163	104	73	81	92	104	115	141	214
60	856	550	346	211	135	88	60	67	77	86	96	120	179
80	638	410	260	159	102	66	45	51	57	64	72	89	134
100	510	325	210	128	82	52	36	41	46	52	58	71	108
120	422	271	175	105	68	44	31	34	38	43	48	60	90
140	364	232	150	92	59	38	26	29	33	37	41	52	77
160	319	220	130	80	51	33	23	25	29	32	36	45	67
180	283	181	120	72	46	29	20	23	26	29	32	40	60
200	254	163	105	64	41	26	18	20	23	25	29	35	52

ASD TR 61-191(II)

IV-61

TABLE IVB-15
 ANDROFORM LIMITS
 COLUMBIUM (10 Mo-10Ti)

Trans. Radius (R _T)	Material Thickness (t)												
	.016	.020	.025	.032	.040	.050	.063	.071	.080	.090	.100	.125	.187
	Longitudinal Radius (R _L)												
	BUCKLING				SPLITTING								
20	378	242	155	95	108	135	174	193	215	240	269	336	497
30	253	165	100	63	72	90	113	126	143	162	177	224	333
40	191	122	77	48	54	67	85	95	108	120	135	167	250
50	151	96	62	38	43	54	68	77	87	97	108	134	200
60	127	81	52	31	36	45	57	63	71	81	90	113	170
80	96	60	38	24	27	34	43	48	54	61	67	85	126
100	76	48	31	19	22	27	34	38	44	49	55	67	100
120	63	41	26	16	18	23	29	32	36	41	45	54	85
140	54	35	22	14	16	19	25	28	31	36	39	49	72
160	47	31	19	12	14	17	21	24	27	31	34	42	63
180	42	27	17	11	12	15	19	21	24	27	30	38	57
200	38	24	16	10	11	14	17	19	21	24	27	34	50

ASD TR 61-191(II)

IV-62

TABLE IVB-16
 ANDROFORM LIMITS
 MOLYBDENUM (0.5% Ti)
 (HOT ROLLED, STRESS RELIEVED, DE-SCALED SHEET)

Trans. Radius (R _T)	Material Thickness (t)												
	.016	.020	.025	.032	.040	.050	.063	.071	.080	.090	.100	.125	.187
	Longitudinal Radius (R _L)												
	BUCKLING						SPLITTING						
20						820	557	619	701	780	872		
30					850	544	374	413	475	525	594	735	
40					638	410	279	314	350	393	445	548	813
50				800	513	328	223	250	283	318	351	438	657
60				653	425	274	187	205	232	264	297	367	554
80			816	500	320	204	139	157	175	198	221	276	410
100			656	400	255	164	112	126	141	160	175	219	326
120		935	544	335	213	136	94	105	117	132	148	185	276
140		735	472	284	183	117	79	89	102	114	126	159	233
160	1000	640	408	250	161	101	70	78	88	100	110	138	212
180	180	570	364	224	143	92	62	70	79	88	98	124	186
200	800	510	328	200	128	82	56	62	70	78	87	110	162

ASD TR 61-191(II)

IV-63

SECTION V
DEEP RECESSING
A. DEEP DRAWING WITH MECHANICAL DIES
B. MANUAL SPINNING

DEEP DRAWING WITH MECHANICAL DIES

Description of the Forming Process

The deep drawing tests in this program were performed using double action dies as shown in the sketch below.

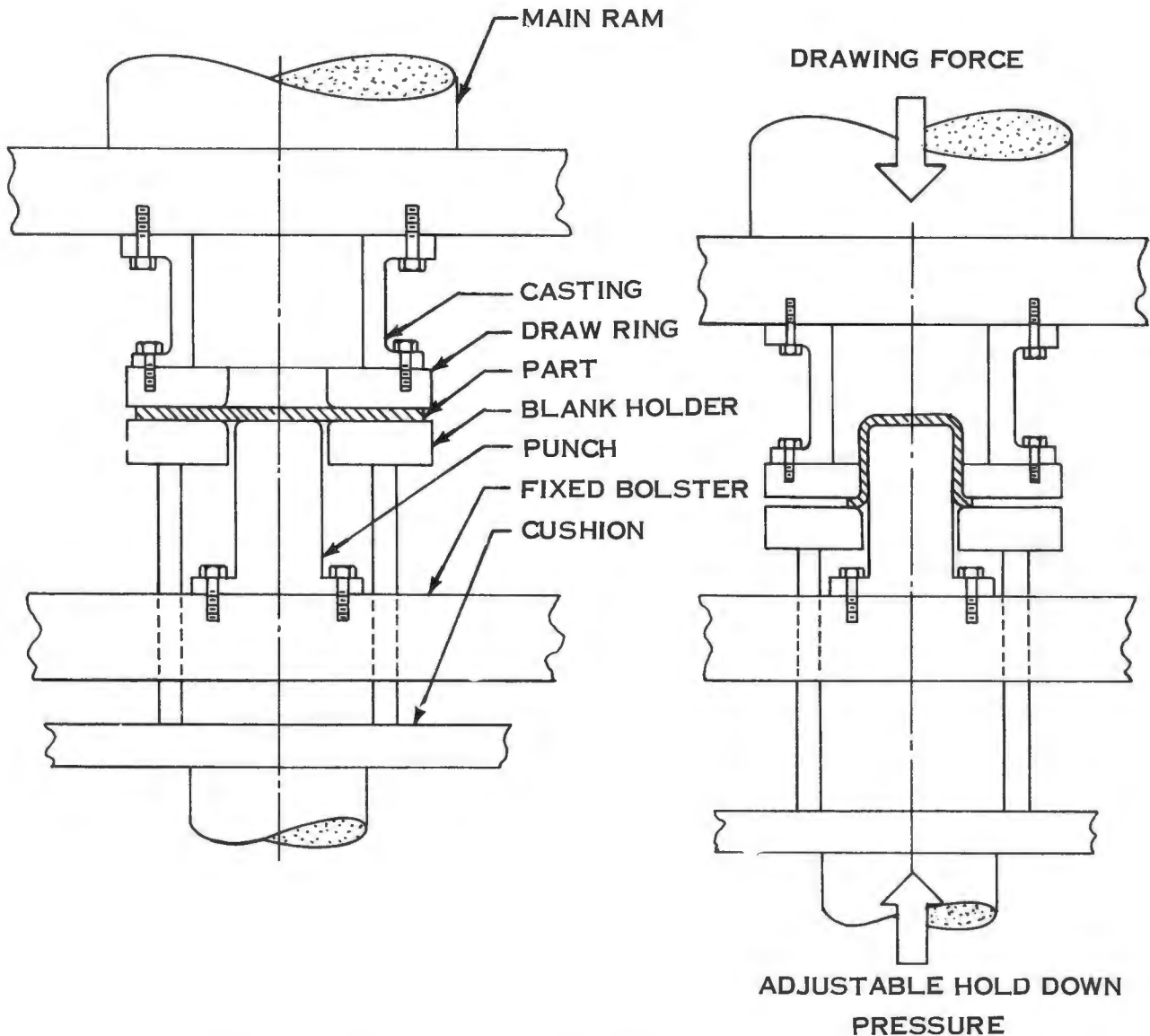

FIGURE V A-1 DOUBLE ACTION DRAW DIE

Equivalent results can be obtained in any press provided with an adjustable blank holder pressure and sufficient power to provide the necessary drawing force.

For the experimental cup forming in this program, dies of the type shown in the above sketch were used in two different presses. The presses used were: (1) the 1000 ton and (2) the 600 ton Lake Erie Hydraulic presses. In both presses the blank holder pressure is obtained from the lower cushion which is air operated on the 600 ton press, and hydraulic on the 1000 ton press with a maximum of 150 tons in both cases.

The forming tool consists of (1) a cylindrical meehanite steel casting used to secure the draw die to the main ram, (2) a draw die, (3) blank holder, and (4) punch. The draw dies and blank holders are hardened steel with hard chrome plating on the surfaces in contact with the part. The cup wall clearance is 20% of the metal thickness. The punches are also hardened steel. The draw die and blank holder are provided with holes to accommodate four 500 watt heaters each for the elevated temperature tests.

The friction between the surfaces of the part and the tool must be held to a minimum for good drawability. Two factors that can influence the frictional force are: (1) the surface condition of the material and (2) the drawing lubricant. The tooling surfaces must be polished and considerably harder than the material being formed.

Although the surface finish does not appear to influence drawability to any significant extent from friction effects, materials such as the H-11 tool steels may be supplied with a heavy oxide surface coating that scales off during the draw operation. A good general purpose lubricant such as "International Drawing Compound #155DS" is essential in cupping all materials at room temperature. A colloidal graphite preparation such as "Electrofilm T-22" is recommended for elevated temperature cupping.

The applicability of this data to cupping with single action presses using rigid blank holders involves certain qualifications. Drawability is reduced considerably in the rigid type blank holders unless a critical amount of clearance is provided for the thickening of the material.

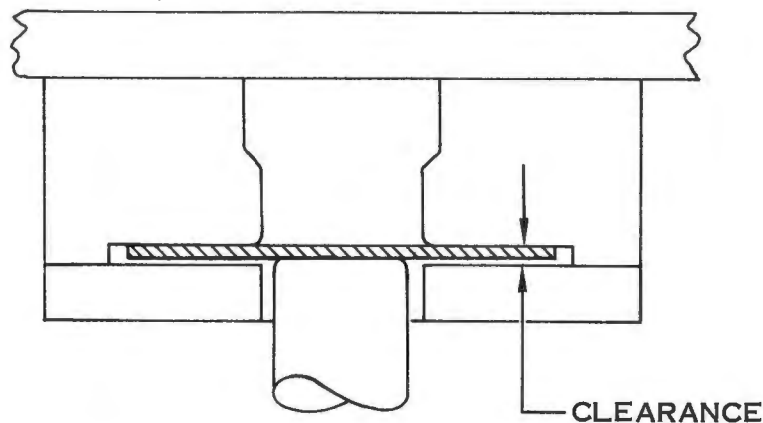

FIGURE V A-2 SINGLE ACTION DRAW DIE

Too great a clearance may result in an excessive draw force because of buckling while insufficient clearance will create a condition similar to that of excessive blank holder pressure in double

action tools. Applicability would also depend to a large extent on the type of material being considered.

In general, particular attention must be paid to the pressure distribution on the blank holder, the surface condition of the draw die, and the blank holder. Any scratches or marks on these surfaces perpendicular to the direction of movement of the material can seriously reduce the drawability.

Definition of Part Shape and Geometrical Variables

The part shape for this investigation is limited to thin walled cylindrical cups. The geometrical variables involved are shown below.

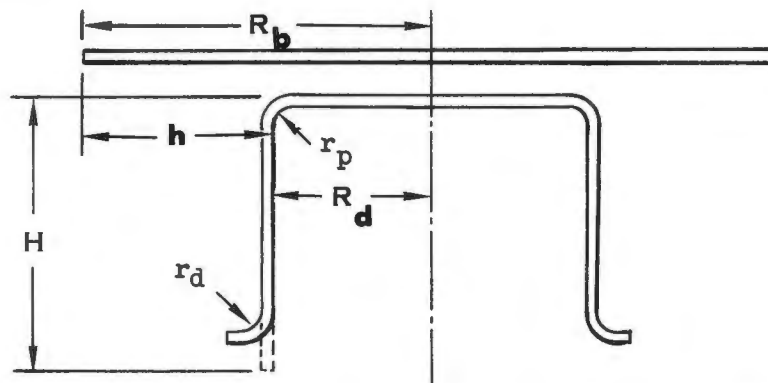

FIGURE V A-3 GEOMETRICAL VARIABLES FOR CUPPING

R_b = Radius of the blank

R_d = Radius of the die

$h = R_b - R_d$ = overhang flange width

H = finished height of cup with no flange

r_p = radius of the punch

r_d = draw radius

t = material thickness

The radius of the blank (R_b) and the radius of the die (R_d) are used to define drawability. The end radius of the punch r_p was held constant at 5/8 inches. The draw die corner radius r_d was made equal to ten times the material thickness. These values of r_p and r_d were selected to obtain maximum drawability for a wide variety of materials. For values of r_d greater than $10t$ excessive blank holder pressure would be required to prevent buckling in unsupported material around the die radius. This condition is often termed "puckering." Smaller values of r_p and r_d cannot be used for materials with limited bend ductility. Although materials with good bendability could be formed at lower values of r_d , the tension in the cup wall raises with smaller values of r_d ; hence, the drawing limit is reduced.

The drawability is defined as the maximum value of the ratio h/R_b that results in a cup free of defects. Plotting h/R_b vs. h/t on log-log paper yields a curve with the following shape:

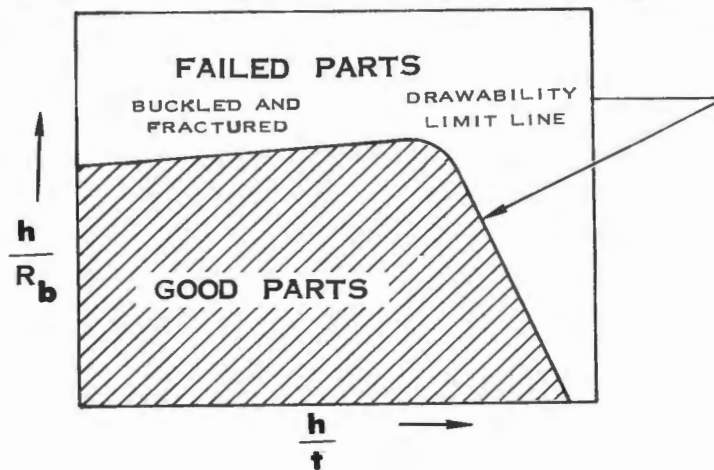

FIGURE V A-4 TYPICAL THEORETICAL FORMABILITY CURVE FOR THIN WALLED CYLINDRICAL CUPS

Since $h = R_b - R_d$, only the values of three variables (R_b , R_d , and t) are required to determine if the blank can be successfully cupped. Similarly, if the material thickness and the cup or die diameter is given, then the largest blank can be determined graphically by assigning values to R_b as shown below:

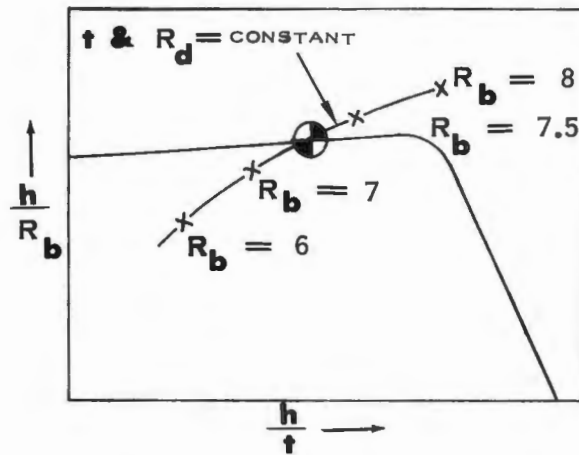

FIGURE V A-5 TYPICAL FORMABILITY CURVE SHOWING A CONSTANT R_d/t LINE

A series of constant t and R_d lines can be superimposed over the drawability curve and values of R_b obtained graphically.

The drawability limit lines for various materials fall in different locations on the graph:

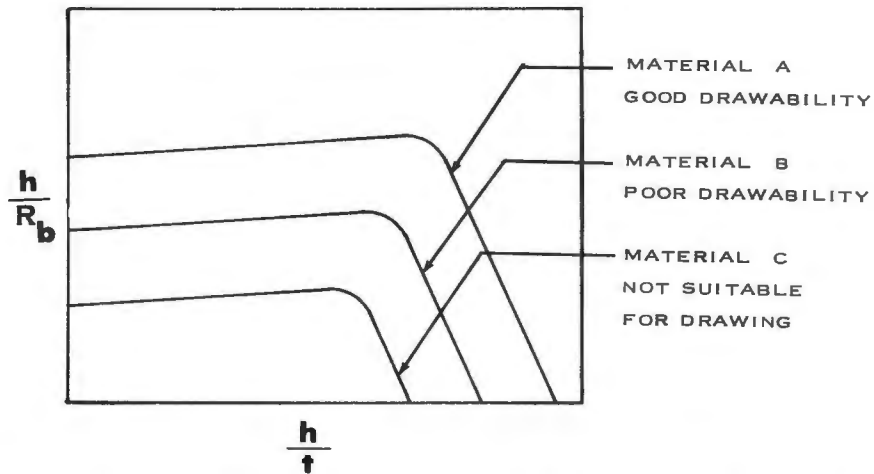

FIGURE V A-6 TYPICAL FORMABILITY CURVES ILLUSTRATING THE POSITION OF VARIOUS MATERIALS

There is a correlation between certain mechanical properties of a material and the drawability of the material; hence, the drawability of any material may be predicted on the basis of its mechanical properties.

Predictability Equations

The index I for cupping is:

$$I = \frac{E}{S_{CY}} \times \frac{S_{TY}}{S_{CY}}$$

where:

E = Elastic Modulus

S_{CY} = Compressive Yield Strength

S_{TY} = Tensile Yield Strength

The value of the index I increases with increasing drawability and may, therefore, be used to position the forming limit lines on the graph. The shape of the curve, on a log-log plot, is defined by the following equations:

Plastic Buckling Limit Line

$$\frac{h}{R_b} = 0.258 \left[I \times 10^{-1} \right]^{.139} \left[\frac{h}{t} \right]^{.0506} \quad \text{EQUATION I}$$

Elastic Buckling Limit Line

$$\frac{h}{R_b} = 27.0 \left[I \right]^{.618} \left[\frac{h}{t} \right]^{-2} \quad \text{EQUATION II}$$

In order to simplify the development of the limit lines on a composite graph, the following index lines and points (where the limit lines and index lines intersect) are given.

Index Lines

$$\frac{h}{R_b} = 0.258 \left[\frac{h}{t} \right]^{0.19} \quad \text{EQUATION III}$$

$$\frac{h}{R_b} = 3.96 \times 10^8 \left[\frac{h}{t} \right]^{-5.24} \quad \text{EQUATION IV}$$

Intersection Points

$$\frac{h}{R_b} = I \times 10^{-3} \quad \text{EQUATION V}$$

$$\frac{h}{t} = I \times 10^{-1} \quad \text{EQUATION VI}$$

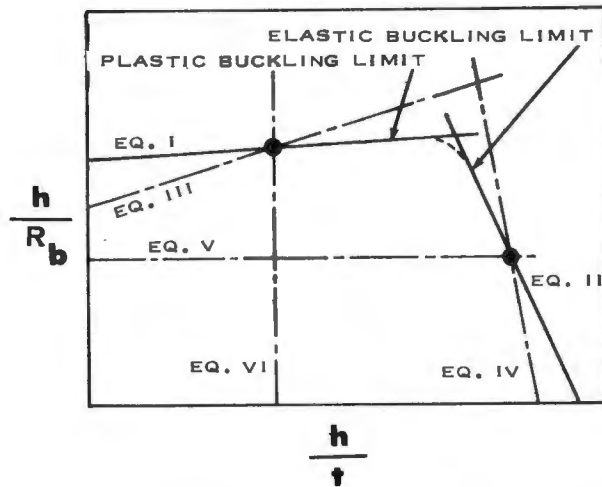

FIGURE V A-7 TYPICAL FORMABILITY CURVE AND INDEX LINES

Use of the predictability equations to determine the formability limit line for a particular material can best be illustrated by the following example:

Step 1: Calculate the value of I:

For Tungsten at 1000 °F:

$$E = 50.5 \times 10^6$$

$$S_{CY} = 101.5 \times 10^3 \quad \therefore I = \frac{E}{S_{CY}} \times \frac{S_{TY}}{S_{CY}} = 542$$

$$S_{TY} = 110.4 \times 10^3$$

Step 2: Locate the index lines from Equations (III) and (IV).

The index lines for cupping are plotted as follows:

1. For Equation (III) the slope of the line is .19 and its intercept on the h/R_B axis is .40.
2. For Equation (IV) the slope is -5.42 and the h/t intercept is 68.

From this, the index lines are constructed as shown below:

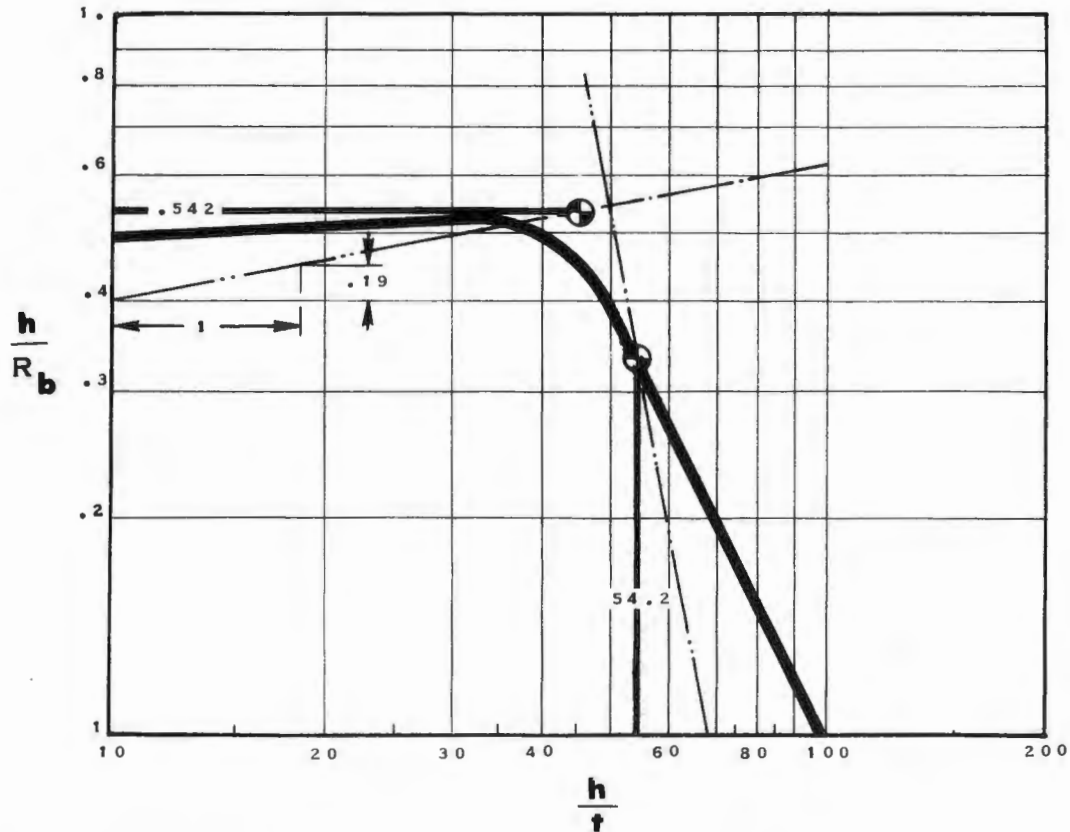

FIGURE V A-8 SAMPLE CONSTRUCTION OF THE THEORETICAL FORMABILITY LIMIT CURVE FOR TUNGSTEN AT 1000° F

From Equation (V) the elastic buckling limit line for tungsten intersects the index line at $\frac{h}{t} = I \times 10^{-1} = 54.2$ and has a slope of -2. From Equation (VI) the plastic buckling limit line for tungsten intersects its index line at $\frac{h}{R_b} = I \times 10^{-3} = .542$ and has a slope of .051. The two segments of the formability limit line are joined with a smooth curve.

Composite Graphs

The composite graphs are based on average values of the mechanical properties reported in Progress Report #4. The predicted cupping limits for a majority of the program materials were verified experimentally.

Five materials presented special problems with regards to experimental verification as outlined in the following chart:

Material	$\frac{E}{Scy}$	$\frac{Sty}{Scy}$	Temperature (°F)	Experimental Verification
HM21XA-T8	495		R.T.	Note (1)
Beryllium	3970		1200	Note (2)
Molybdenum .5 Ti	432		900	Note (3)
Columbium 10 Mo-10 Ti	177		R.T.	Note (1)
Tungsten	542		1000	Note (3)

FIGURE V A-9 MATERIALS REQUIRING SPECIAL MENTION

Note (1): HM21XA-T8 and columbium (10 Mo-10 Ti) at room temperature do not exhibit a typical drawing failure. In both these materials failure originated in the bend radius of the punch and proceeded across the blank on a line 45° to the grain direction. Since the drawing index is based on failure in the cup wall, experimental verification cannot be expected.

Note (2): Beryllium at 1200°F failed in a brittle manner in bend radii. By the same reasoning applied to HM21XA-T8 and columbium (10 Mo-10 Ti) in Note (1), beryllium at 1200°F cannot be evaluated.

Note (3): The experimental cup tests for molybdenum and tungsten were performed at 600°F . At this temperature, which is above the brittle to ductile transition temperatures of the metals, reasonably good agreement was obtained between the test data and the predicted formability at the

higher temperatures. This indicates that the forming temperature is not critical once the material is in its ductile range.

Graph VA-2 shows an alternate method of plotting the critical variables, n , R_0 , and t , for a given material; in this case 2024-0 aluminum. This type of graph has the advantage that values of the parameters may be read off directly thus eliminating the calculations required when using Graph VA-1.

GRAPH V A-I

COMPOSITE GRAPH OF DEEP DRAW
LIMITS FOR CYLINDRICAL CUPS

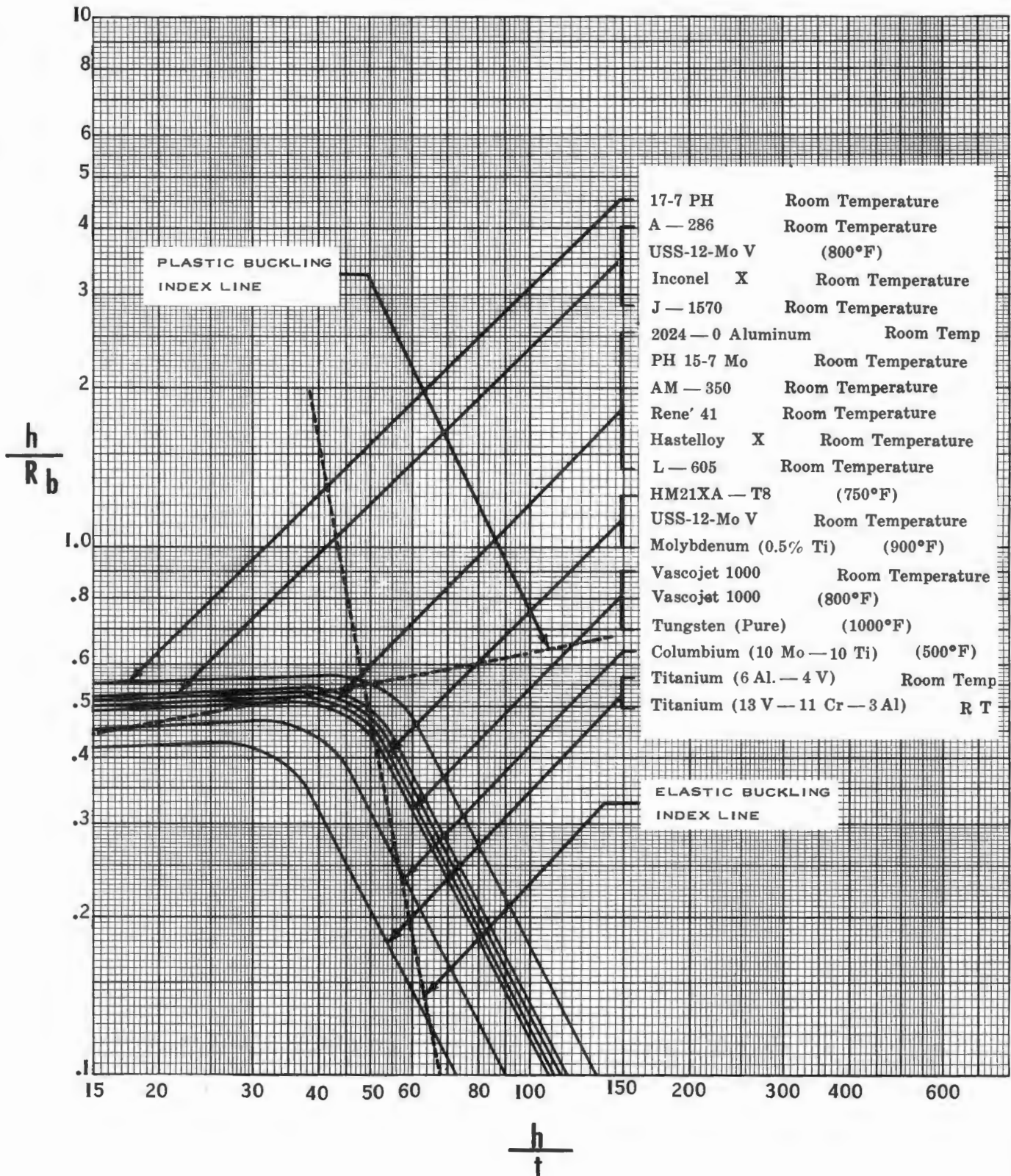

GRAPH V A-2
 ALTERNATE METHOD OF PLOTTING
 DEEP DRAW FORMABILITY LIMITS
 2024-0 ALUMINUM

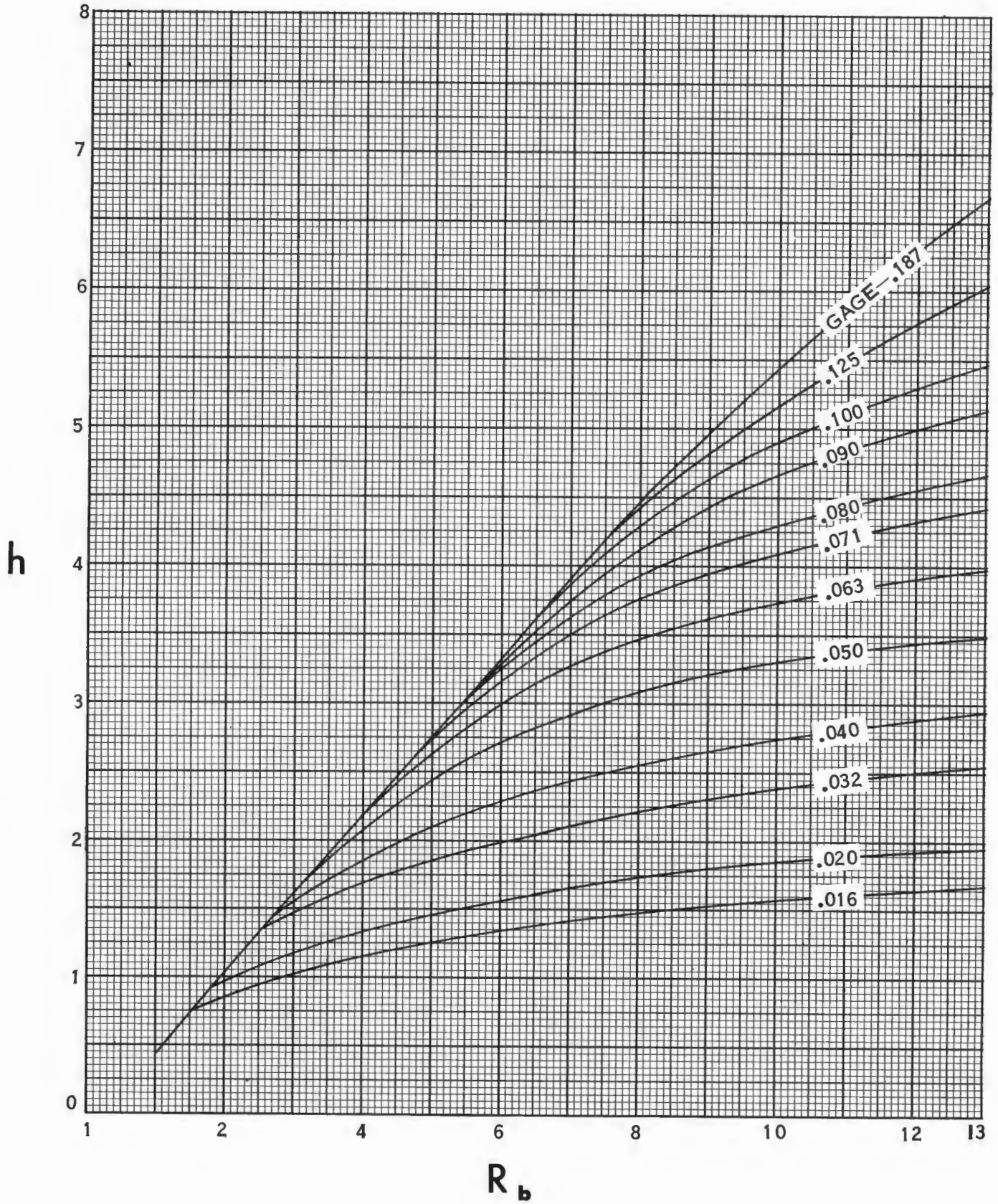

Design Tables

The design tables were obtained from the composite graphs. The values of R_d , R_b , h , and t were obtained by overlay plots as described in the previous section. The value of H , the height of an unflanged cup, was calculated using the following equation:

For convenience, the variables may be plotted as follows:

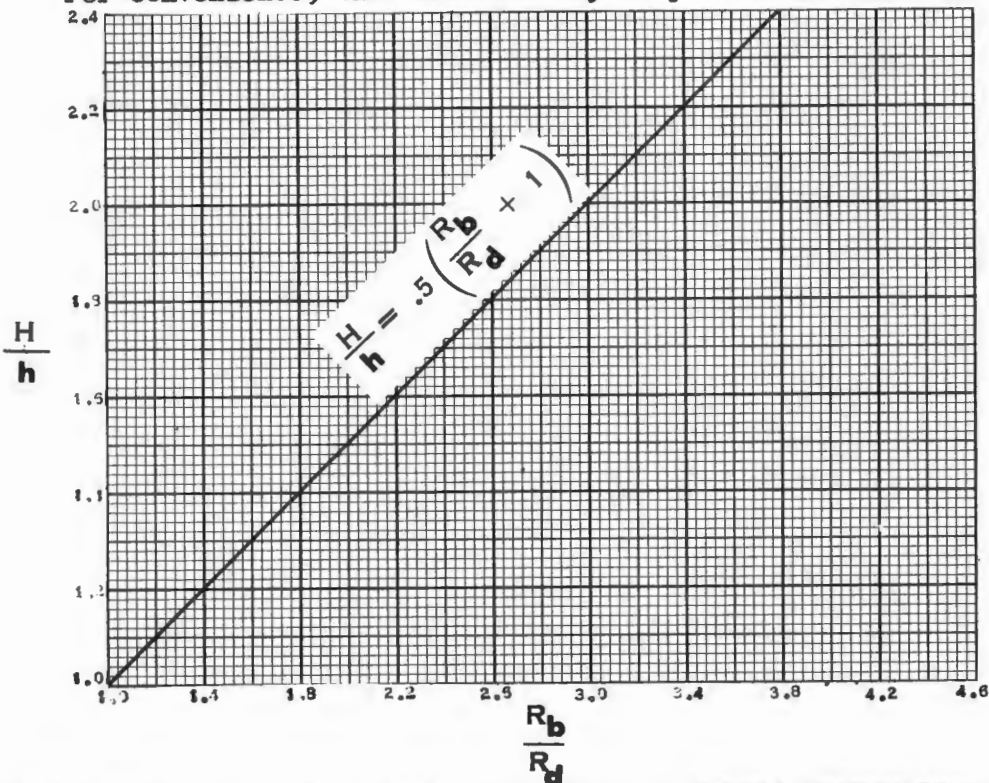

FIGURE V A-10 CURVE FOR CONVERTING FROM OVERHANG (h) TO FINAL CUP HEIGHT (H)

The value of H for cupping is based on a constant volume and a net material thickness change of zero. Production conditions that favor thinning of the cup wall (such as ironing) because of minimum metal clearance between the punch and die or oversize material gage, will result in a larger value of H than is predicted, provided the material does not fracture as a result of the increased cup wall tension that results from these conditions.

It should also be pointed out that under conditions where a certain amount of buckling and ironing can be tolerated, the stated formability limits are conservative. This is particularly true in the cupping of soft materials such as aluminum and magnesium (at elevated temperature) where die wear is not a problem. The following sketches illustrate this point.

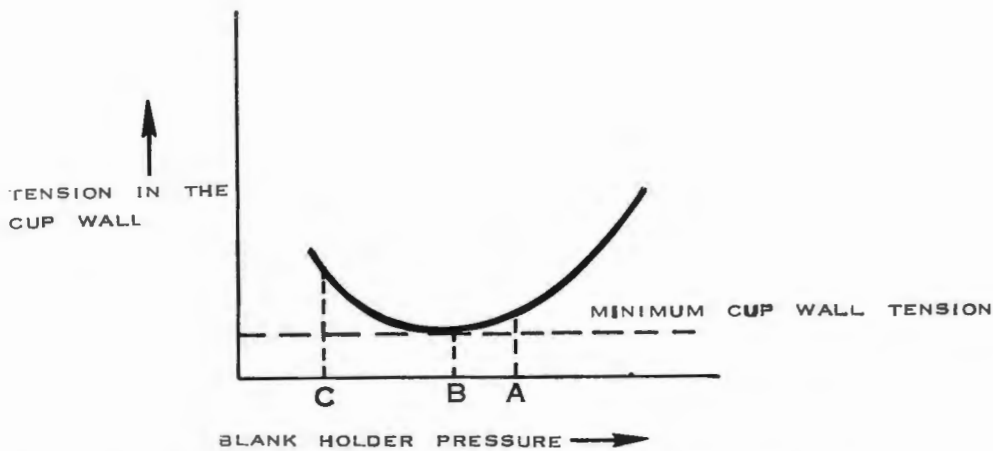

FIGURE VA-II CUP WALL TENSION VS. BLANK HOLDER PRESSURE

- A = The minimum pressure required to prevent flange buckling.
- B = The ideal pressure required to produce maximum formability where flange buckling and ironing is permitted.
- C = A low pressure such that the ironing action raises the cup wall tension excessively.

The design tables are based on blank holding pressure in the range from B to A which represents a comparatively small range of pressures. On the splitting limit curves, the increase in drawability obtained is shown as follows:

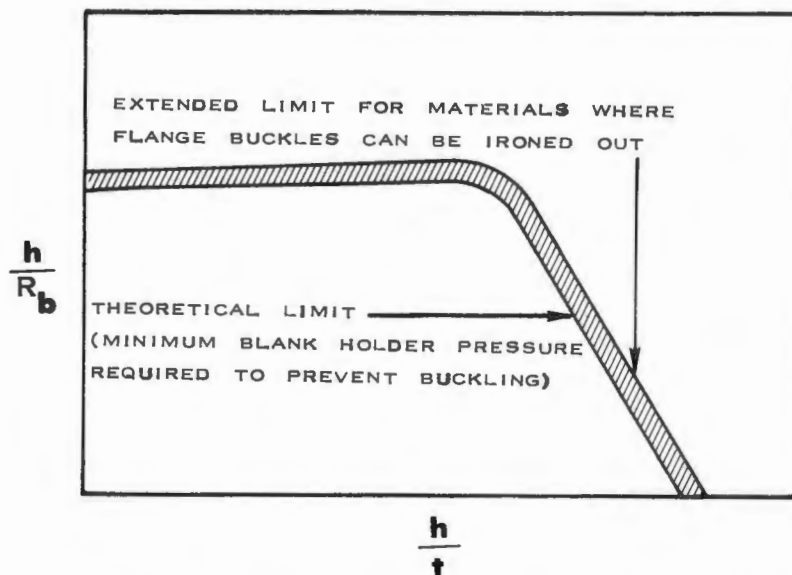

FIGURE V A-12 FORMABILITY LIMIT INCREASE FROM REDUCED BLANK HOLDER PRESSURE

TABLE VA-1
DEEP DRAWING LIMITS FOR CYLINDRICAL CUPS
17-7 PH
(ANNEALED CONDITION "A")

Gage (t)		.016	.020	.025	.032	.040	.050	.063	.071	.080	.090	.100	.125	.187
Die Diameter (D _d)		Flange Height (H): Blank Diameter (D _b)												
1	D _b	2.4	2.3	2.3	2.3									
	H	1.2	1.1	1.1	1.1									
2	D _b	3.9	4.2	4.5	4.8	4.6	4.5	4.5						
	H	1.4	1.7	2.1	2.3	2.1	2.0	2.0						
3	D _b	5.1	5.5	6.0	6.5	6.9	7.1	7.0	7.0	6.8	6.7			
	H	1.4	1.7	2.2	2.7	3.2	3.4	3.3	3.2	3.1	3.0			
4	D _b	6.2	6.4	7.1	7.8	8.4	9.1	9.5	9.5	9.3	6.2	6.1	5.9	
	H	1.4	1.7	2.2	2.8	3.5	4.1	4.6	4.6	4.4	4.3	3.2	3.0	
5	D _b	7.4	7.8	8.7	9.0	9.7	10.5	11.3	11.7	11.8	11.7	11.6	11.4	
	H	1.5	1.8	2.2	2.8	3.5	4.3	5.1	5.6	5.8	5.6	5.5	5.3	
6	D _b	8.5	8.9	9.4	10.1	10.9	11.9	12.8	13.4	13.9	14.1	14.2	13.4	13.4
	H	1.5	1.8	2.2	2.8	3.5	4.3	5.3	5.9	6.5	6.8	6.8	6.6	5.9
7	D _b	9.6	10.0	10.6	11.3	12.1	13.1	14.2	14.8	15.4	15.9	16.3	16.4	15.8
	H	1.5	1.8	2.2	2.8	3.5	4.4	5.4	6.1	6.7	7.3	7.8	7.8	7.2
8	D _b	10.7	11.1	11.7	12.4	13.3	14.3	15.5	16.2	16.9	17.5	18.1	18.7	18.3
	H	1.6	1.9	2.3	2.8	3.5	4.4	5.5	6.2	6.9	7.6	8.2	8.9	8.4
9	D _b	11.7	12.2	12.8	13.6	14.4	15.4	16.7	17.5	18.2	19.0	19.7	20.1	20.8
	H	1.6	1.9	2.3	2.9	3.5	4.4	5.5	6.2	6.9	7.7	8.5	9.8	9.8
10	D _b	12.8	13.3	13.9	14.7	15.6	16.6	17.8	18.7	19.4	20.3	21.1	22.4	23.3
	H	1.6	1.9	2.3	2.9	3.5	4.4	5.5	6.2	6.9	7.8	8.6	10.0	11.1

ASD TR 61-191(II)

V-18

TABLE VA-2
DEEP DRAWING LIMITS FOR CYLINDRICAL CUPS

A-286
(SOLUTION TREATED)

USS-12-MoV
(ANNEALED) AT 800 °F

INCONEL X
(C.R. ANNEALED)

J-1570
(SOLUTION TREATED)

Gage (t)		.016	.020	.025	.032	.040	.050	.063	.071	.080	.090	.100	.125	.187
Die Diameter (D _d)		Flange Height (H): Blank Diameter (D _b)												
1	D _b	2.2	2.2	2.1										
	H	1.0	0.9	0.9										
2	D _b	3.7	4.0	4.3	4.5	4.3	4.3							
	H	1.2	1.5	1.8	2.0	1.8	1.8							
3	D _b	4.9	5.2	5.7	6.1	6.5	6.6	6.7	6.4	6.4				
	H	1.2	1.5	1.9	2.4	2.8	2.9	2.9	2.7	2.6				
4	D _b	6.0	6.4	6.8	7.4	8.0	8.5	8.9	8.8	8.6	8.6	8.5		
	H	1.3	1.6	1.9	2.4	3.0	3.6	3.9	3.8	3.7	3.6	3.6		
5	D _b	7.1	7.5	7.8	8.6	9.3	10.0	10.7	11.0	11.0	10.9	10.8	10.6	
	H	1.3	1.6	2.0	2.5	3.1	3.7	4.4	4.7	4.7	4.6	4.6	4.4	
6	D _b	8.2	8.7	9.1	9.8	10.5	11.3	12.2	12.7	13.0	13.2	13.2	12.9	
	H	1.3	1.6	2.0	2.5	3.1	3.9	4.7	5.2	5.5	5.7	5.7	5.5	
7	D _b	9.3	9.8	10.3	10.9	11.6	12.5	13.5	14.1	14.6	15.0	15.4	15.2	14.7
	H	1.4	1.6	2.0	2.5	3.1	3.9	4.8	5.3	5.9	6.3	6.7	6.5	6.0
8	D _b	10.4	10.9	11.4	12.1	12.8	13.7	14.8	15.4	16.0	16.6	17.1	17.6	17.1
	H	1.4	1.7	2.1	2.6	3.1	3.9	4.8	5.4	6.0	6.6	7.1	7.7	7.2
9	D _b	11.5	12.0	12.5	13.2	14.0	14.9	16.0	16.7	17.4	18.0	18.7	19.7	19.3
	H	1.4	1.7	2.1	2.6	3.2	3.9	4.8	5.5	6.1	6.7	7.4	8.5	8.1
10	D _b	12.6	13.0	13.6	14.3	15.1	16.0	17.2	17.9	18.6	19.4	20.0	21.3	21.6
	H	1.5	1.7	2.1	2.6	3.4	3.9	4.9	5.5	6.1	6.9	7.5	8.7	9.1

TABLE VA-3
DEEP DRAWING LIMITS FOR CYLINDRICAL CUPS

2024-0 ALUMINUM

PH 15-7 Mo
(ANNEALED CONDITION "A")

AM-350
(ANNEALED)

RENE '41
(SOLUTION TREATED)

HASTELLOY X
(SOLUTION TREATED)

L-605
(SOLUTION TREATED)

Gage (t)		.016	.020	.025	.032	.040	.050	.063	.071	.080	.090	.100	.125	.187
Die Diameter (D _d)	Flange Height (H): Blank Diameter (D _b)													
1	D _b	2.2	2.1	2.1										
	H	0.9	0.8	0.8										
2	D _b	3.7	4.0	4.2	4.4	4.2	4.2							
	H	1.2	1.5	1.7	1.9	1.7	1.7							
3	D _b	4.8	5.2	5.6	6.0	6.4	6.4	6.4	6.3	6.2				
	H	1.2	1.5	1.8	2.3	2.6	2.7	2.7	2.5	2.4				
4	D _b	6.0	6.3	6.8	7.3	7.9	8.4	8.7	8.5	8.4	8.4	8.4		
	H	1.2	1.5	1.9	2.4	2.9	3.4	3.7	3.6	3.5	3.4	3.4		
5	D _b	7.1	7.5	7.9	8.5	9.2	9.8	10.5	10.7	10.8	10.6	10.6	10.5	
	H	1.3	1.5	1.9	2.4	3.0	3.6	4.1	4.5	4.5	4.4	4.4	4.3	
6	D _b	8.3	8.6	9.0	9.8	10.3	11.2	12.0	12.4	12.7	12.9	12.9	12.7	12.3
	H	1.3	1.6	1.9	2.4	3.0	3.7	4.5	5.0	5.2	5.4	5.4	5.2	4.8
7	D _b	9.4	9.7	10.2	10.8	11.5	12.4	13.3	13.9	14.3	14.7	15.0	14.9	14.5
	H	1.4	1.6	1.9	2.4	3.0	3.7	4.5	5.1	5.6	6.0	6.3	6.2	5.8
8	D _b	10.2	10.8	11.3	11.9	12.7	13.6	14.6	15.2	15.7	16.3	16.8	17.2	16.8
	H	1.4	1.6	2.0	2.4	3.0	3.7	4.5	5.2	5.7	6.2	6.8	7.3	6.8
9	D _b	11.5	11.9	12.4	13.1	13.8	14.7	15.8	16.5	17.1	17.8	18.3	19.2	19.0
	H	1.4	1.7	2.0	2.4	3.0	3.7	4.7	5.2	5.8	6.5	7.1	8.0	7.8
10	D _b	12.6	13.0	13.5	14.2	14.9	15.8	16.9	17.8	18.3	19.1	19.7	20.1	21.2
	H	1.5	1.7	2.1	2.4	3.1	3.7	4.7	5.4	5.9	6.7	7.7	8.4	8.7

ASD TR 61-191(II)

V-20

TABLE VA-4
 DEEP DRAWING LIMITS FOR CYLINDRICAL CUPS
 HM21XA-T8 (MAGNESIUM THORIUM) MOLYBDENUM USS-12-MoV
 750 °F (.5%Ti.) (H.R.-STRESS RELIEVED) (ANNEALED)
 900 °F

Gage (t)		.016	.020	.025	.032	.040	.050	.063	.071	.080	.090	.100	.125	.187
Die Diameter (D _d)		Flange Height (H): Blank Diameter (D _b)												
1	D _b	2.2	2.1	2.1										
	H	0.9	0.8	0.8										
2	D _b	3.6	3.9	4.1	4.3	4.2	4.1							
	H	1.1	1.4	1.6	1.8	1.7	1.6							
3	D _b	4.8	5.1	5.5	6.0	6.3	6.4	6.3	6.2	6.2				
	H	1.2	1.4	1.8	2.2	2.5	2.7	2.5	2.5	2.4				
4	D _b	5.9	6.3	6.7	7.4	7.8	8.3	8.5	8.5	8.4	8.4	8.3		
	H	1.2	1.4	1.8	2.3	2.8	3.5	3.6	3.5	3.5	3.3	3.3		
5	D _b	7.0	7.4	7.9	8.4	9.1	9.7	10.4	10.6	10.6	10.5	10.4	10.3	
	H	1.2	1.5	1.8	2.3	2.9	3.5	4.1	4.4	4.4	4.3	4.2	4.0	
6	D _b	8.1	8.5	9.0	9.6	10.3	11.1	11.8	12.2	12.6	12.7	12.8	12.5	
	H	1.2	1.5	1.9	2.3	2.9	3.6	4.3	4.7	5.1	5.2	5.3	5.0	
7	D _b	9.2	9.6	10.1	10.7	11.4	12.2	13.2	13.7	14.1	14.6	14.8	14.7	
	H	1.3	1.6	1.9	2.4	2.9	3.6	4.4	5.0	5.4	5.8	6.1	5.8	
8	D _b	10.3	10.7	11.2	11.9	12.6	13.4	14.5	15.0	15.6	16.2	16.6	17.0	16.6
	H	1.3	1.6	1.9	2.4	2.9	3.6	4.5	5.1	5.6	6.2	6.6	7.0	6.6
9	D _b	11.3	11.8	12.3	13.0	13.7	14.6	15.6	16.3	16.9	17.6	18.1	19.0	18.7
	H	1.3	1.6	2.0	2.4	3.0	3.6	4.5	5.1	5.7	6.3	6.9	7.8	7.5
10	D _b	12.4	12.9	13.4	14.1	14.8	15.7	16.8	17.5	18.2	18.9	19.5	20.6	20.8
	H	1.4	1.7	2.0	2.4	3.0	3.8	4.5	5.2	5.7	6.4	7.0	8.1	8.3

TABLE VA-5
DEEP DRAWING LIMITS FOR CYLINDRICAL CUPS

VASCOJET 1000
(H-11) (ANNEALED)

VASCOJET 1000
(H-11) (ANNEALED) 800°F

TUNGSTEN
(PURE) 1000°F

Gage (t)		.016	.020	.025	.032	.040	.050	.063	.071	.080	.090	.100	.125	.187
Die Diameter (D _d)		Flange Height (H): Blank Diameter (D _b)												
1	D _b	2.1	2.0	2.0										
	H	0.9	0.8	0.7										
2	D _b	3.6	3.8	4.1	4.2	4.1								
	H	1.1	1.3	1.6	1.7	1.6								
3	D _b	4.7	5.1	5.5	5.9	6.2	6.2	6.1	6.0	6.0				
	H	1.1	1.4	1.7	2.1	2.4	2.4	2.4	2.3	2.2				
4	D _b	5.9	6.2	6.6	7.2	7.7	8.1	8.4	8.2	8.1	8.0	8.0		
	H	1.2	1.4	1.7	2.2	2.7	3.1	3.4	3.2	3.1	3.0	3.0		
5	D _b	7.0	7.3	7.8	8.4	9.0	9.6	10.1	10.3	10.3	10.2	10.2	10.0	
	H	1.2	1.4	1.8	2.2	2.8	3.3	3.9	4.1	4.0	4.0	3.9	3.8	
6	D _b	8.1	8.4	8.9	9.5	10.1	10.9	11.6	12.0	12.3	12.4	12.4	12.2	
	H	1.3	1.5	1.8	2.3	2.8	3.5	4.1	4.5	4.8	4.9	4.9	4.7	
7	D _b	9.2	9.6	10.0	10.6	11.3	12.1	13.0	13.5	13.9	14.2	14.5	14.4	
	H	1.3	1.5	1.8	2.3	2.8	3.5	4.3	4.7	5.2	5.5	5.7	5.6	
8	D _b	10.3	10.7	11.1	11.8	12.4	13.3	14.2	14.8	15.3	15.9	16.3	16.5	16.1
	H	1.3	1.5	1.9	2.3	2.8	3.5	4.3	4.9	5.3	5.8	6.3	6.5	6.1
9	D _b	11.3	11.7	12.2	12.9	13.6	14.4	15.4	16.1	16.6	17.3	17.8	18.6	18.2
	H	1.3	1.6	1.9	2.4	2.9	3.5	4.4	4.9	5.4	6.0	6.6	7.3	7.0
10	D _b	12.4	12.8	13.3	14.0	14.7	15.5	16.6	17.3	17.9	18.6	19.2	20.2	20.3
	H	1.4	1.6	1.9	2.4	2.9	3.5	4.4	4.9	5.5	6.2	6.7	7.7	7.8

TABLE VA-6
DEEP DRAWING LIMITS FOR CYLINDRICAL CUPS
COLUMBIUM
(10M0-10T1) AT 500°F

Gage (t)		.016	.020	.025	.032	.040	.050	.063	.071	.080	.090	.100	.125	.187
Die Diameter (D _d)		Flange Height (H): Blank Diameter (D _b)												
1	D _b	1.9	1.8											
	H	0.7	0.6											
2	D _b	3.4	3.6	3.8	3.8	3.7								
	H	0.9	1.1	1.3	1.3	1.2								
3	D _b	4.5	4.8	5.1	5.5	5.6	5.6	5.6						
	H	0.9	1.2	1.4	1.7	1.9	1.9	1.8						
4	D _b	5.6	5.8	6.2	6.8	7.1	7.5	7.6	7.5	7.4	7.4			
	H	1.0	1.2	1.4	1.9	2.2	2.5	2.6	2.4	2.4	2.4			
5	D _b	6.6	7.0	7.4	7.9	8.4	8.9	9.4	9.5	9.4	9.4	9.2		
	H	1.0	1.2	1.5	1.9	2.3	2.7	3.2	3.3	3.1	3.1	3.0		
6	D _b	7.8	8.2	8.5	9.0	9.8	10.2	10.8	11.1	11.3	11.3	11.2	11.1	
	H	1.1	1.3	1.5	1.9	2.4	2.8	3.4	3.6	3.8	3.8	3.7	3.7	
7	D _b	8.9	9.2	9.7	10.2	10.7	11.4	12.2	12.3	12.8	13.1	13.2	13.1	
	H	1.1	1.3	1.6	2.0	2.4	2.9	3.5	3.9	4.1	4.4	4.5	4.4	
8	D _b	10.0	10.4	10.7	10.3	11.9	12.6	13.4	13.9	14.3	14.7	15.0	15.2	15.4
	H	1.1	1.4	1.6	2.0	2.4	2.9	3.6	4.0	4.4	4.7	5.0	5.2	4.4
9	D _b	11.1	11.4	11.8	12.4	13.0	13.7	14.6	15.1	15.6	16.1	16.5	17.0	15.6
	H	1.1	1.4	1.6	2.0	2.4	3.0	3.7	4.1	4.5	5.0	5.3	5.6	5.4
10	D _b	12.1	12.5	13.0	13.6	14.1	14.8	15.7	16.3	16.8	17.4	17.8	18.7	18.7
	H	1.2	1.4	1.7	2.1	2.5	3.0	3.7	4.1	4.6	5.1	5.4	6.2	6.2

TABLE VA-7
DEEP DRAWING LIMITS FOR CYLINDRICAL CUPS

TITANIUM
(6Al-4V) (ANNEALED)

TITANIUM
(13V-11Cr-3Al) (SOLUTION TREATED)

Gage (t)		.016	.020	.025	.032	.040	.050	.063	.071	.080	.090	.100	.125	.187
Die Diameter (D _d)		Flange Height (H): Blank Diameter (D _b)												
1	D _b	1.7												
	H	0.5												
2	D _b	3.2	3.3	3.5	3.5									
	H	0.8	0.9	1.0	1.1									
3	D _b	4.3	4.5	4.8	5.0	4.2	4.2							
	H	0.8	1.0	1.2	1.4	1.3	1.5							
4	D _b	5.4	5.7	6.6	6.4	6.7	7.0	7.0	7.0					
	H	0.8	1.0	1.2	1.5	1.8	2.1	2.1	2.1					
5	D _b	6.5	6.8	7.1	7.5	7.9	8.4	8.7	8.8	8.7	8.7			
	H	0.9	1.0	1.2	1.6	1.9	2.2	2.6	2.6	2.6	2.6			
6	D _b	7.6	7.8	8.2	8.6	9.1	9.6	10.2	10.4	10.5	10.5	10.5		
	H	0.9	1.0	1.3	1.6	1.9	2.3	2.8	3.0	3.1	3.1	3.1		
7	D _b	8.6	8.9	9.3	9.7	10.2	10.8	11.5	11.8	12.1	12.2	12.3	12.2	
	H	0.9	1.1	1.3	1.6	2.0	2.4	2.9	3.2	3.4	3.5	3.7	3.6	
8	D _b	9.9	10.0	10.4	10.8	11.3	11.9	12.7	13.1	13.4	13.7	14.0	14.0	
	H	1.0	1.1	1.4	1.7	2.0	2.4	3.0	3.3	3.6	3.9	4.1	4.1	
9	D _b	10.8	10.1	11.4	11.9	12.4	13.0	13.8	14.3	14.7	15.1	15.5	15.8	
	H	1.0	1.2	1.4	1.7	2.0	2.4	3.1	3.4	3.7	4.1	4.4	4.6	
10	D _b	11.9	12.1	12.5	13.0	13.5	14.2	14.9	15.4	14.9	16.4	16.7	17.4	
	H	1.0	1.3	1.4	1.7	2.1	2.5	3.1	3.4	3.8	4.2	4.5	5.1	

ASD TR 61-191(II)

V-24

MANUAL SPINNING

Description of Forming Process

Although manual spinning is used for the production of a wide variety of part shapes, in this program the scope was necessarily limited to a "single stage" operation, that is, the cups were spun directly from a circular blank to the cylindrical mandrel in one spinning operation with out preforming or annealing stages. The mechanical set up used is shown in Figure VB-1:

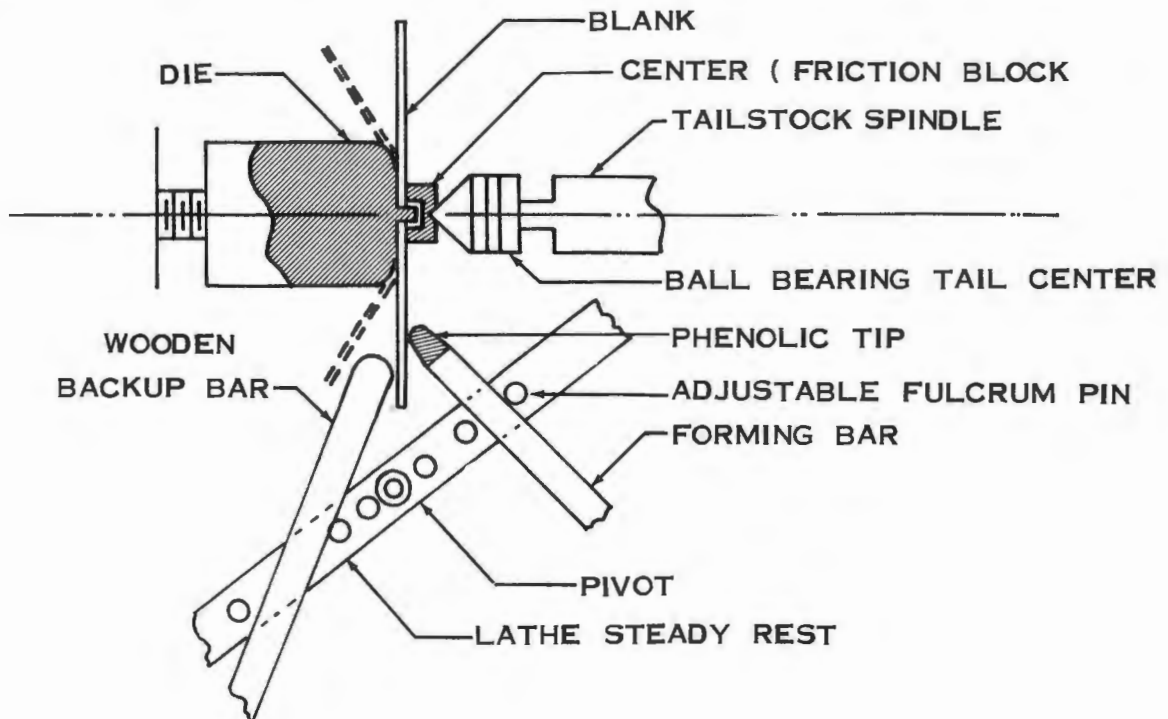

FIGURE VB-1 A SINGLE STAGE SETUP FOR MANUAL SPINNING

The equipment requirements for manual spinning are not severe. A rigidly built lathe of sufficient power is, however, a necessity.

The tooling requirements, particularly the mandrel material, depends on the type of material to be formed, and the required number of parts as well as the part tolerance required. Hardened steel, rather than wood or aluminum, was used in view of the high strength materials to be tested, and the elevated temperature test requirements.

In this type of forming, operator skill is unquestionably a vital factor. The correct procedures with regard to spinning speed, and application of the forming forces must be varied for different material gages of a particular material. Similarly, the procedures for obtaining maximum formability differs from material to material. Lubrication of the part is necessary to prevent galling of the part by the forming bar. The best lubricant for spinning aluminum, stainless steel, tool steels and super alloys, at room temperature is a mixture of petroleum grease and graphite. Vaseline with graphite may also be used. "Moly cote" is the recommended lubricant for elevated temperature spinning of all alloys and for the spinning of Titanium and magnesium at room temperature.

Definition of Part Shape and Geometric Variables

The part shape for this investigation is limited to thin walled cylindrical cups. The geometrical variables involved are shown in Figure VB-2:

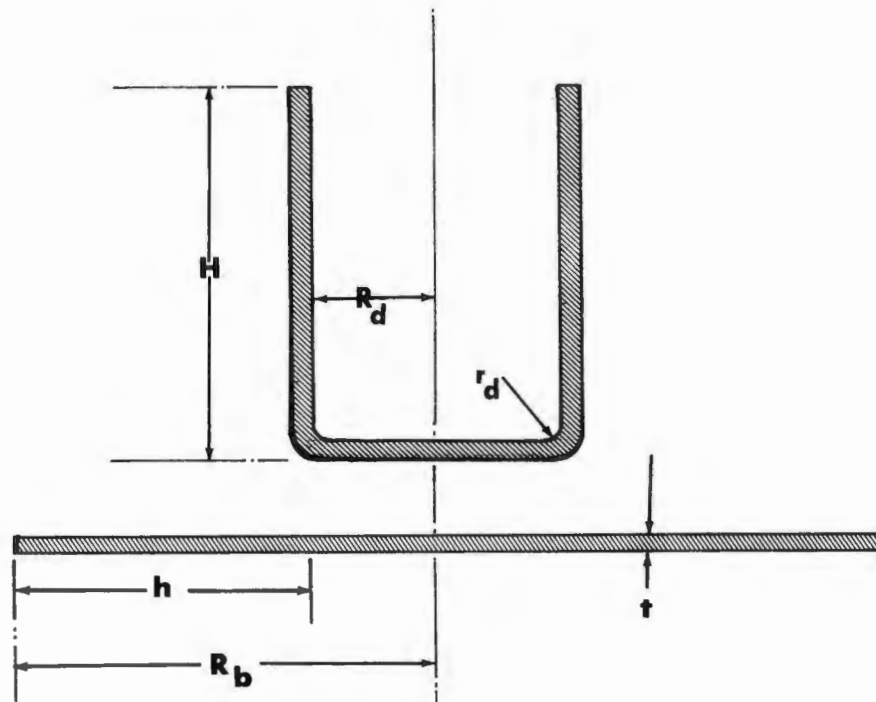

FIGURE VB-2 GEOMETRIC VARIABLES FOR SPINNING

The radius of the blank (R_b) and the radius of the die (R_d) are used to define the forming limits.

The end radius of the die (r_d) should be made sufficiently large to avoid excess thinning. For the dies used in this program, the end radius was held constant at three-eighths inches, which is sufficiently large for materials with low bend ductility and is well over the standard minimum corner radius of $5T$, normally specified in spinning dies.

The formability limit in spinning is defined by the value of (h/R_b) . Plotting h/R_b vs h/t on log-log graph paper yields a curve with the characteristic shape shown in Figure VB-3:

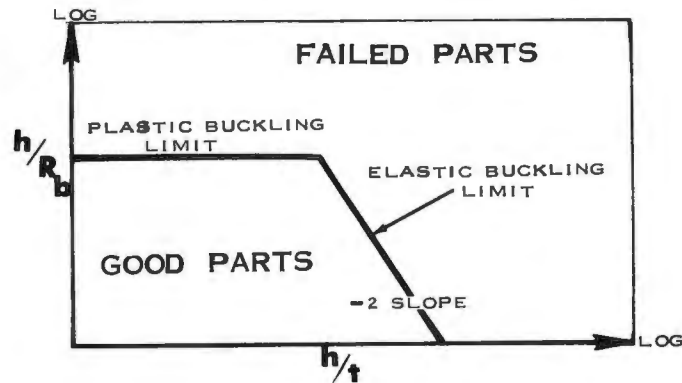

FIGURE VB-3 THEORETICAL FORMABILITY CURVE FOR SPINNING

The elastic buckling limit line appears on the graph as a straight line that has a slope of -2. The plastic buckling limit is associated with heavy gages and appears on the graph as a straight horizontal line.

Since the over hang flange height (h) is the difference between R_b and R_d , only three parameters R_b , R_d and t , are required to define the formability limit line. In addition to the plastic and elastic buckling limits imposed by the material properties there is a machine limit that further restricts the spinning process. The machine limits are dependent on the strength or toughness of the material and its gage. Figure VB-4 illustrates the machine limits:

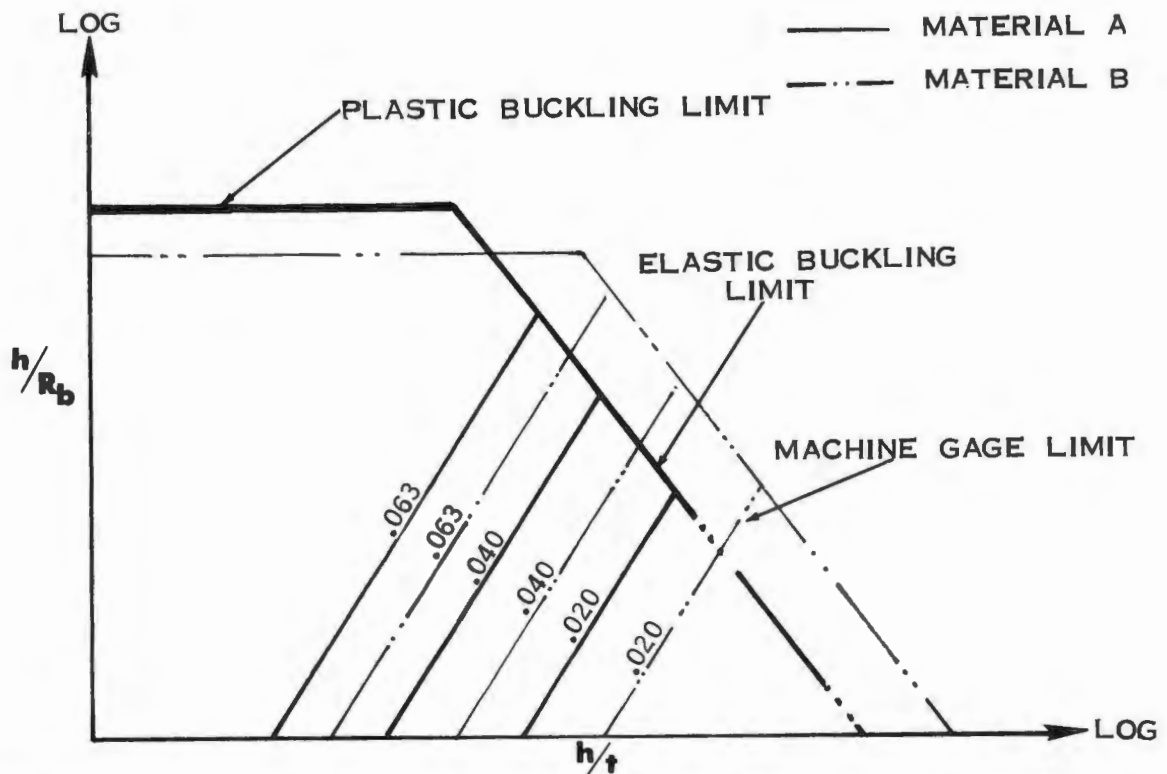

FIGURE VB-4 FORMING LIMIT CURVES FOR SPINNING SHOWING MACHINE LIMITS

In both the elastic and plastic ranges there is a correlation between the spinning formability and certain mechanical properties of the materials; hence, the formability can be predicted theoretically for any material. The machine limits have been established empirically and correlated to the strength of the materials; therefore, the machine limits can be predicted for any material.

Predictability Equations

The following predictability equations are used to determine the spinning formability for any material.

Plastic Buckling Forming Limit Line:

$$\frac{h}{R_b} = 0.162 \left[\frac{E}{S_u} \times 10^{-2} \right]^{0.91}$$

EQUATION I

The index line for this limit is:

$$\frac{h}{R_b} = 0.162 \left[\frac{h}{t} \right]^{0.91}$$

EQUATION II

Elastic Buckling Forming Limit Line:

$$\frac{h}{R_b} = \left[\frac{E}{S_{CY}} \right]^{1.769} \left[\frac{.00485}{(h/t)^2} \right]$$

EQUATION III

The index line for this limit is:

$$\frac{h}{R_b} = 0.0001279 (h/t)^{2.6}$$

EQUATION IV

The intersection points of the index lines and the forming limit lines are as follows:

Elastic limit intersection point:

$$\frac{h}{R_b} = \frac{E}{S_{CY}} \times 10^{-3}$$

EQUATION V

Plastic limit intersection point:

$$\frac{h}{R_b} = \frac{E}{S_u} \times 10^{-2}$$

EQUATION VI

Figure V B-5 illustrates these lines plotted on log-log coordinates

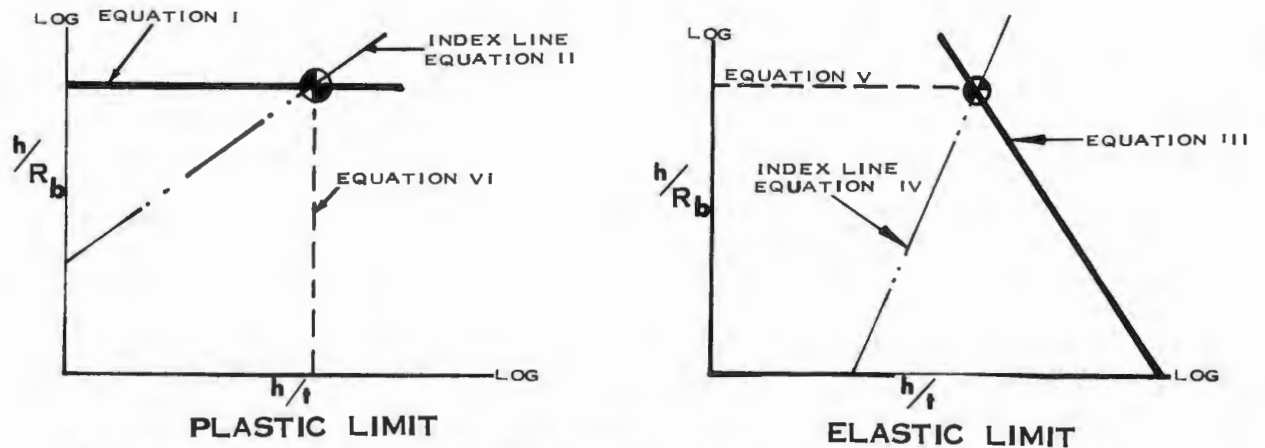

FIGURE VB-5 PLASTIC AND ELASTIC LIMITS

The machine limits are a function of the material properties and the gage. For this reason, two index lines have been established. One index line (I) position the curve based upon the mechanical properties. The other index line (II) position the curve based upon the gage. The following equations were developed:

The equation for index line I:

$$\frac{h}{R_b} = .072 (h/t)^{0.40} \quad \text{EQUATION VII}$$

The equation for index line II:

$$\frac{h}{R_b} = \left[8.13 \times 10^{-4} \right] \left[\frac{E}{S_u} \times 10^{-3} \right]^{-1.7} \left[\frac{h}{t} \right]^{1.08} \quad \text{EQUATION VIII}$$

The equation for the machine limit for each gage and material is:

$$\frac{h}{R_b} = \frac{\left[4.787 \times 10^{-7} \right] \left[t \right]^{2.96} \left[\frac{h}{t} \right]^{4.27}}{\left[E/S_u \times 10^{-3} \right]^{6.74}} \quad \text{EQUATION IX}$$

The intersection point between index line I and index line II is:

$$\frac{h}{R_b} = \frac{E}{S_u} \times 10^{-3} \quad \text{EQUATION X}$$

The intersection point between index line II and the machine limit curve is:

$$\frac{h}{R_b} = \frac{1}{t} \times 10^{-2} \quad \text{EQUATION XI}$$

Figure VB-6 illustrates these lines plotted on log-log coordinates.

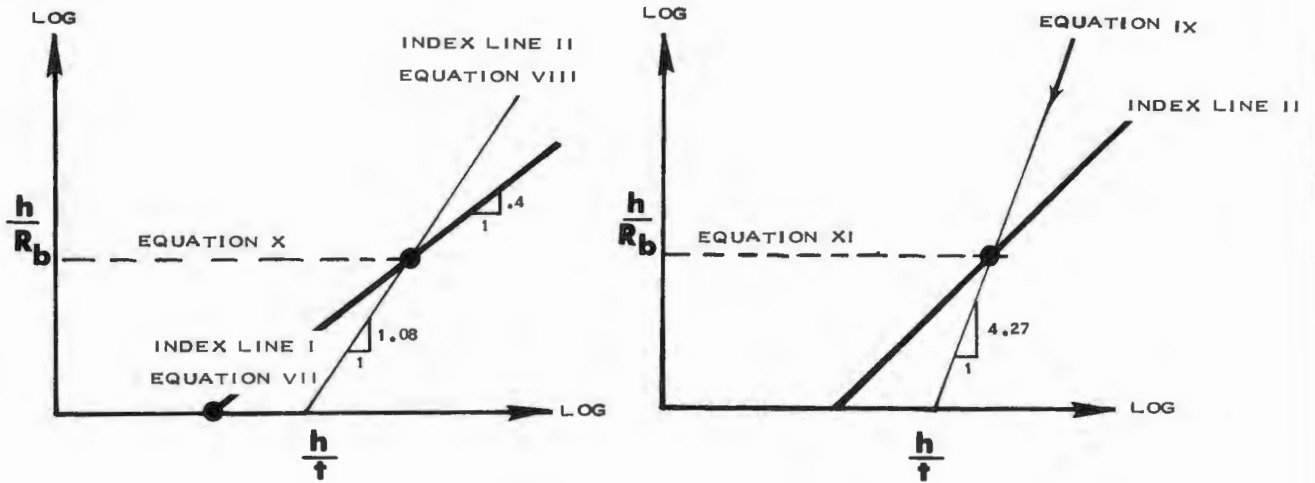

FIGURE VB-6 MACHINE LIMIT CURVES FOR SPINNING

Forming limit curves can be constructed from the preceding equation: by knowing the mechanical properties and following the procedure in Figures VB-5 and VB-6. The equations are summarized in figure V B-7:

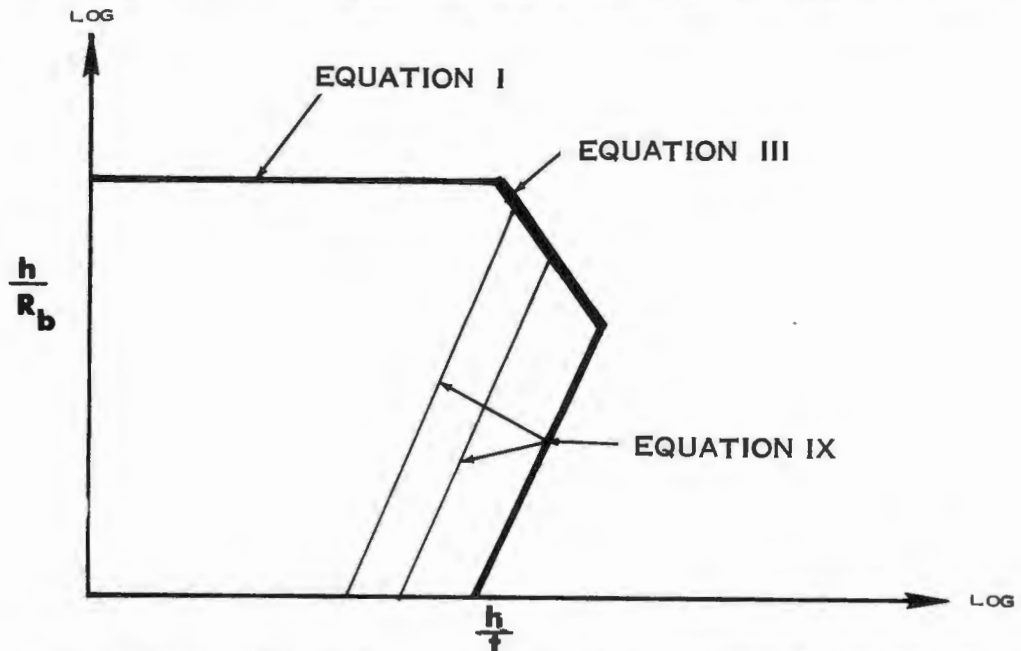
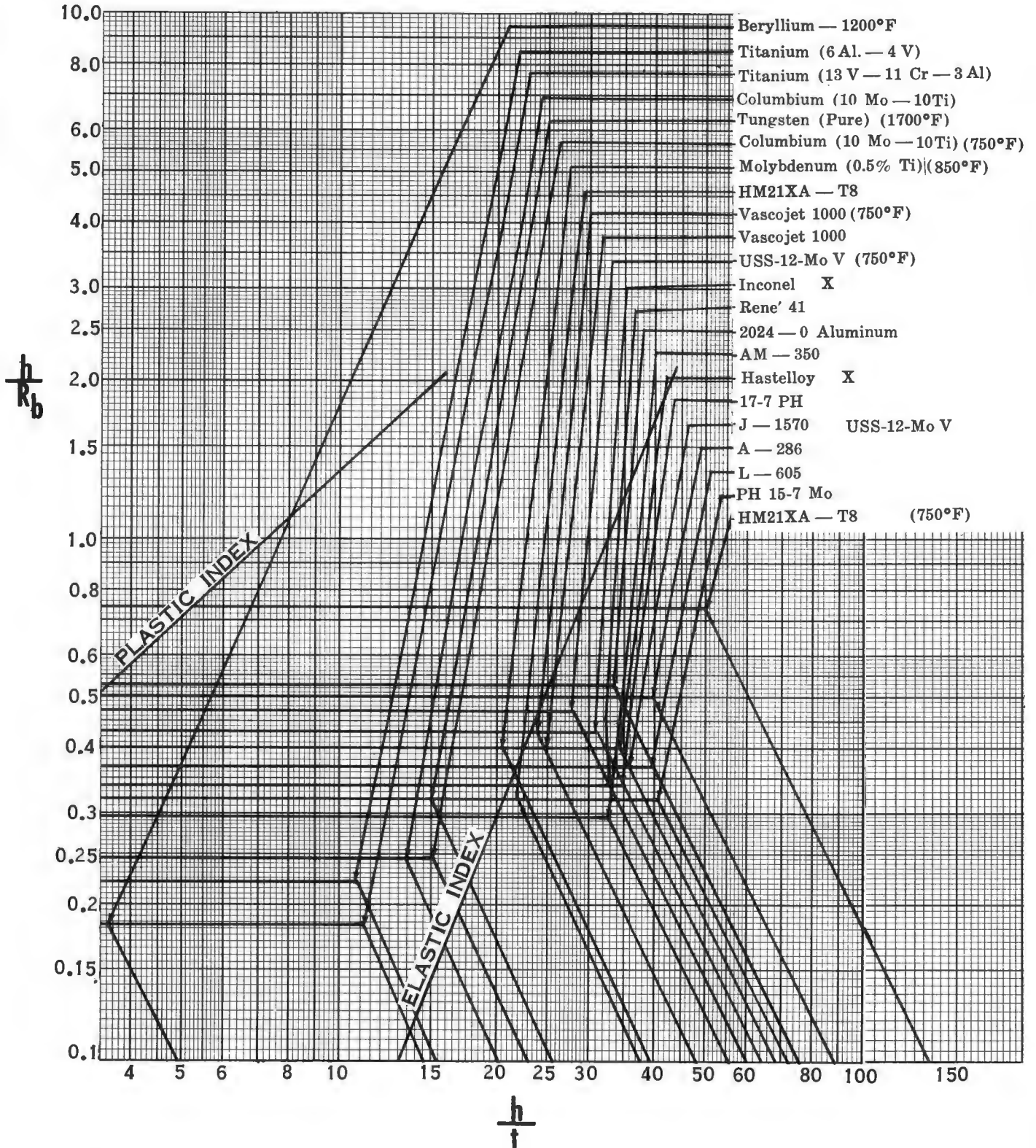

FIGURE VB-7 PREDICTABILITY EQUATION FOR SPINNING IN GRAPH FORM

Composite Graphs

Graph VB-1 is the composite graph for plastic and elastic buckling limits for all of the program materials. Graph VB-2 is the composite graph of the machine limit index lines (index line II) for all materials. Graph VB-3 is a complete composite graph for the elastic and plastic buckling limits along the machine limits for each gage of 2024-0 aluminum. Graph VB-4 illustrates an alternate method of plotting the formability limits. The limiting value of (h) can be read directly from the graph for 2024-0 aluminum.

GRAPH V B-I
SPINNING COMPOSITE FOR ELASTIC
AND PLASTIC BUCKLING LIMITS



GRAPH V B-2
MANUAL SPINNING
COMPOSITE GRAPH OF
MACHINE LIMIT INDEX LINES II

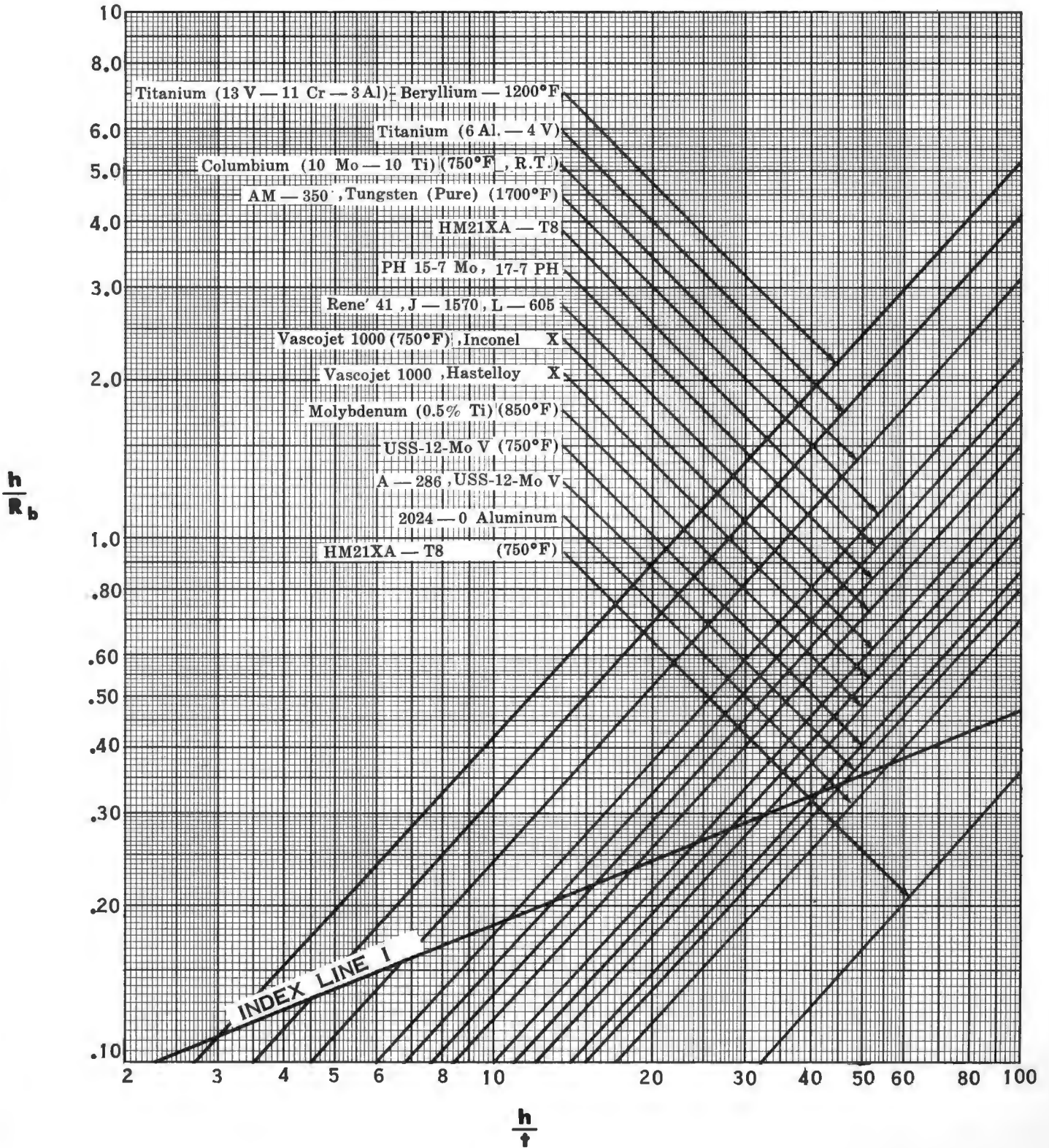

GRAPH V B-3
 MANUAL SPINNING MACHINE GAGE LIMITS
 2024-0 ALUMINUM

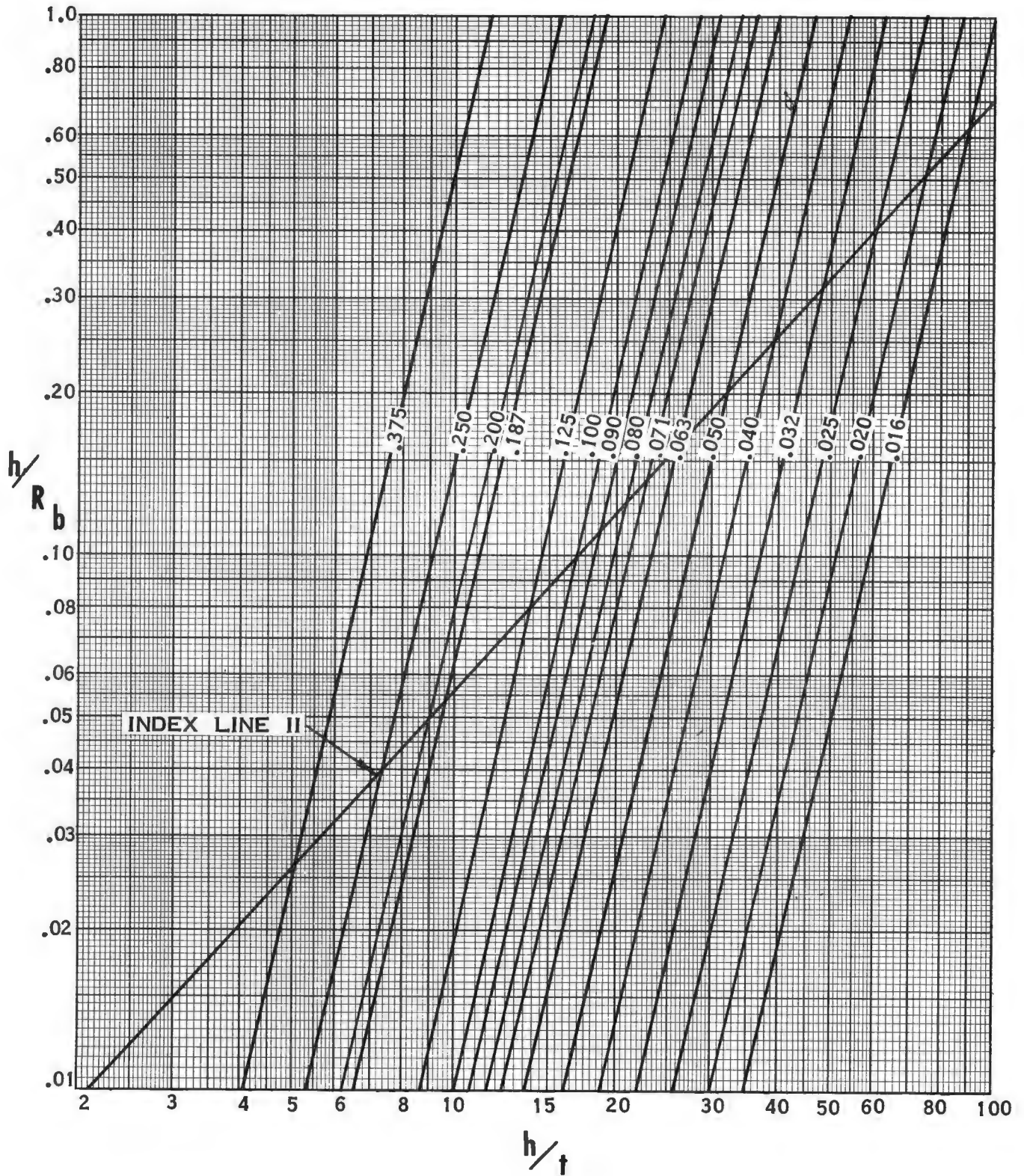

GRAPH V B - 4
 ALTERNATE METHODS OF PLOTTING
 SPINNING FORMABILITY LIMITS

2024-0 ALUMINUM

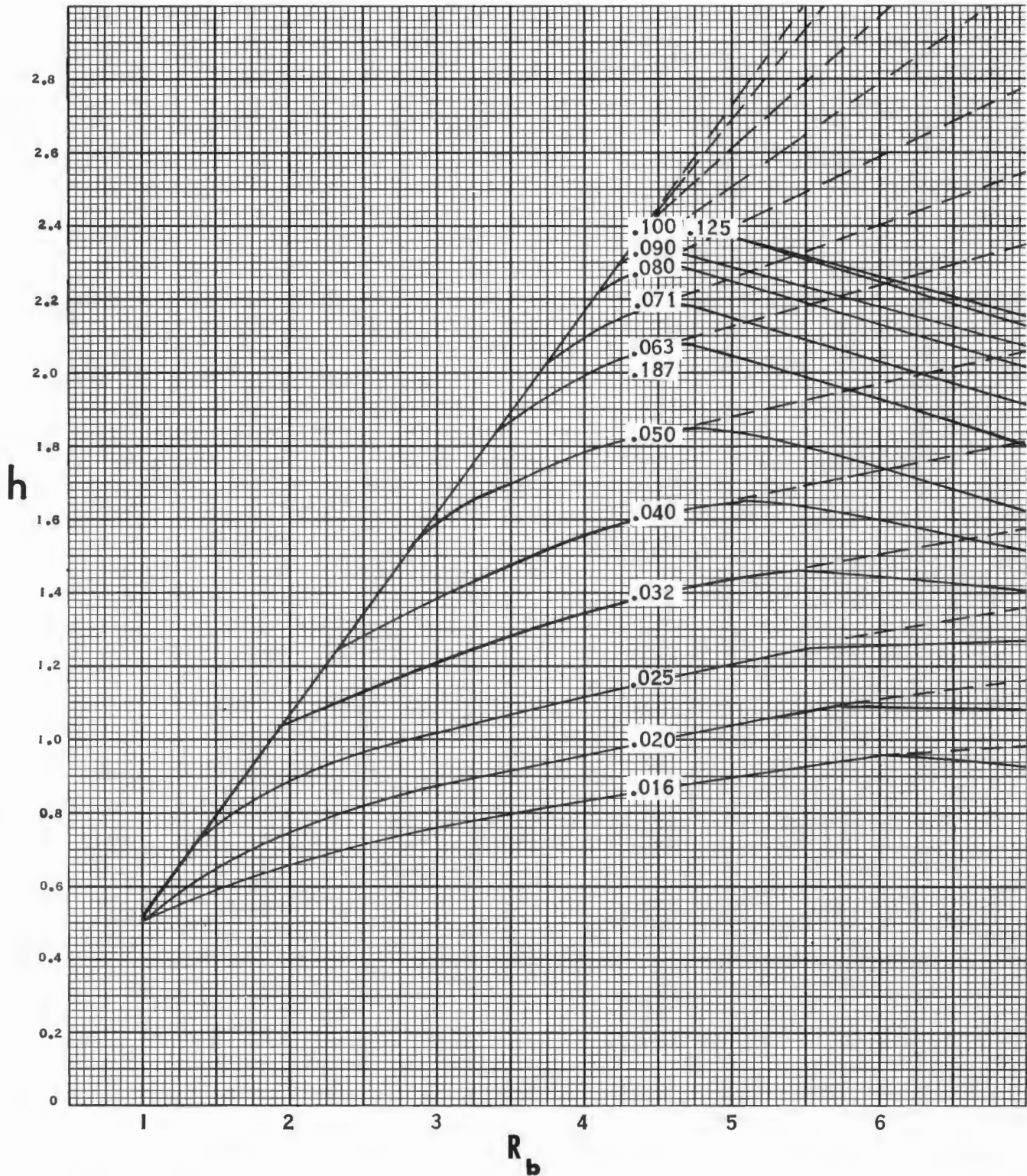

DESIGN TABLES

Design tables have been established for the materials on this program and are given in Tables VB-1 through VB-23. The values of D_b , D_d , h and t shown in the design tables were taken directly from the composite graphs. The value of H , the final cup height, is determined from equation XII.

$$\frac{H}{h} = .641 (D_b/D_d + 1) \qquad \text{EQUATION XII}$$

Equation XII in graphical form is shown in Figure VB-8:

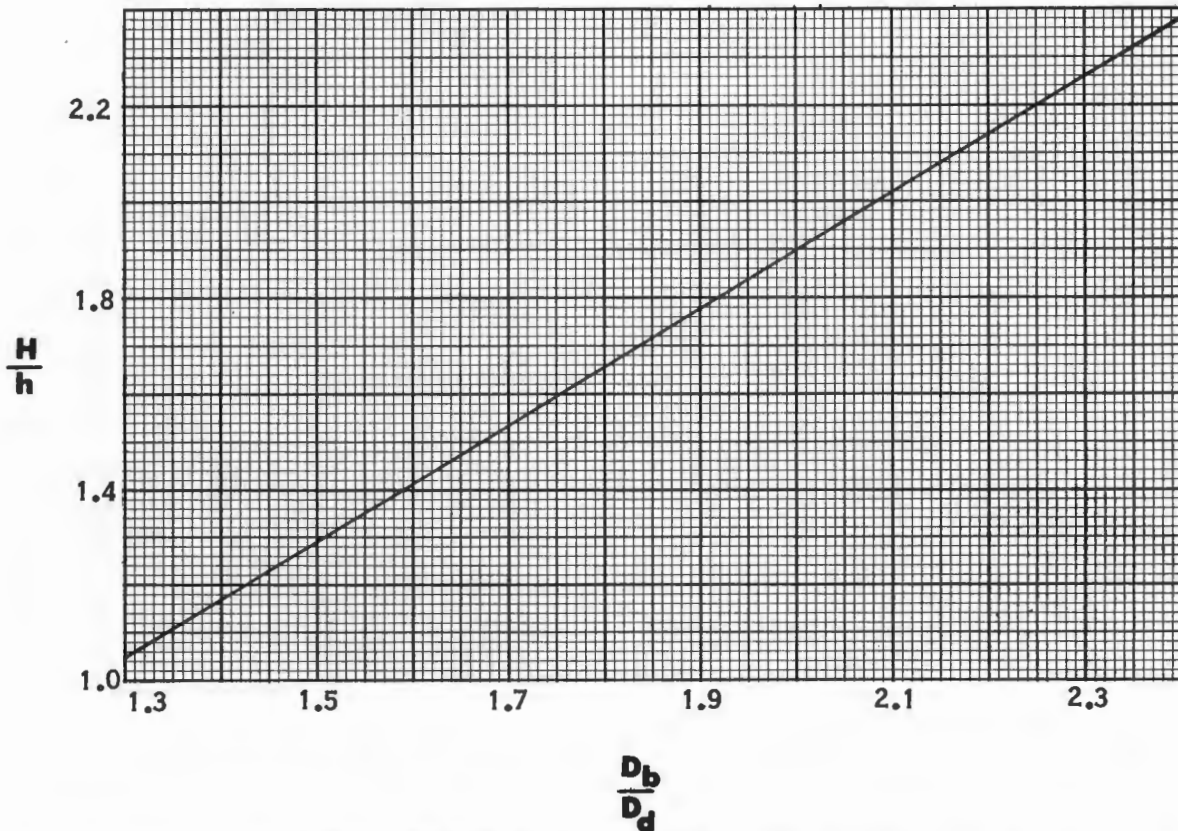

FIGURE VB-8 CURVE FOR CONVERTING FROM OVERHANG (h) TO FINAL CUP HEIGHT (H)

As can be seen by this graph the finished cup height is larger than the original over hang flange width (h). Although much of this difference is a result of "free" elongation, the average cup wall thickness is considerably less than the original metal thickness. The equation for determining H has been verified with test data from a representative variety of different materials and gages.

TABLE VB-1
 MANUAL SPINNING LIMITS
 HM21XA-T8 (MAGNESIUM THORIUM)

Gage (t)		.016	.020	.025	.032	.040	.050	.063	.071	.080	.090	.100	.125	.187
Die Diameter (D _d)	Flange Height (H): Blank Diameter (D _b)													
1	D _b	1.37	1.38	1.38										
	H	.28	.28	.28										
2	D _b	2.71	2.78	2.78										
	H	.54	.60	.60										
3	D _b	3.79	3.93	4.04	4.10	4.15	4.16							
	H	.58	.69	.79	.84	.89	.90							
4	D _b	4.86	4.96	5.02	5.08	5.13	5.18	5.24	5.27	5.31	5.35	5.37	5.45	5.54
	H	.62	.69	.74	.80	.83	.87	.92	.95	.98	1.02	1.04	1.11	1.18
5	D _b	5.90	5.95	6.00	6.05	6.10	6.16	6.20	6.25	6.29	6.32	6.35	6.42	6.60
	H	.63	.67	.71	.75	.79	.83	.86	.91	.94	.96	.99	1.05	1.20
6	D _b	6.89	6.94	6.98	7.03	7.09	7.14	7.18	7.22	7.27	7.30	7.32	7.40	7.57
	H	.62	.65	.68	.72	.76	.80	.83	.87	.90	.93	.94	1.01	1.15
7	D _b	7.87	7.92	7.96	8.01	8.07	8.12	8.16	8.20	8.25	8.28	8.30	8.37	8.55
	H	.60	.63	.66	.69	.74	.78	.81	.84	.88	.90	.91	.97	1.11
8	D _b	8.86	8.91	8.95	8.99	9.05	9.10	9.14	9.19	9.23	9.26	9.28	9.35	9.53
	H	.58	.62	.65	.68	.72	.76	.79	.82	.85	.87	.89	.95	1.07
9	D _b	9.84	9.89	9.93	9.97	10.04	10.08	10.12	10.17	10.21	10.24	10.26	10.33	10.51
	H	.56	.60	.64	.65	.71	.74	.77	.80	.83	.85	.87	.92	1.06
10	D _b	10.83	10.88	10.92	10.96	11.03	11.07	11.11	11.16	11.20	11.23	11.25	11.32	11.50
	H	.55	.59	.62	.65	.70	.73	.76	.78	.81	.84	.86	.90	1.04

TABLE V B-2
MANUAL SPINNING LIMITS
2024-0 ALUMINUM

Gage (t)		.016	.020	.025	.032	.040	.050	.063	.071	.080	.090	.100	.125	.187
Die Diameter (D _d)	Flange Height (H): Blank Diameter (D _b)													
1	D _b	2.07	2.24	2.24	2.24	2.24	2.24							
	H	1.06	1.30	1.30	1.30	1.30	1.30							
2	D _b	3.24	3.46	3.74	4.13	4.43	4.43	4.43	4.43	4.43	4.43	4.43	4.43	4.43
	H	1.05	1.29	1.62	2.11	2.53	2.53	2.53	2.53	2.53	2.53	2.53	2.53	2.53
3	D _b	4.36	4.60	4.90	5.31	5.73	6.28	6.67	6.67	6.67	6.67	6.67	6.75	6.67
	H	1.07	1.31	1.62	2.07	2.56	3.28	3.82	3.82	3.82	3.82	3.82	3.93	3.82
4	D _b	5.47	5.72	6.04	6.48	6.94	7.49	8.19	8.50	8.69	8.69	8.86	8.88	8.23
	H	1.12	1.35	1.65	2.10	2.59	3.24	4.13	4.55	4.80	4.80	5.03	5.04	4.19
5	D _b	6.56	6.83	7.16	7.61	8.06	8.63	9.22	9.38	9.58	9.61	9.78	9.75	9.11
	H	1.16	1.40	1.70	2.13	2.59	3.19	3.89	4.08	4.30	4.35	4.56	4.54	3.74
6	D _b	7.64	7.92	8.26	8.73	9.20	9.70	10.08	10.26	10.46	10.50	10.64	10.64	10.00
	H	1.20	1.44	1.74	2.16	2.62	3.13	3.53	3.73	3.95	4.00	4.17	4.17	3.46
7	D _b	8.71	9.00	9.36	9.83	10.30	10.60	10.97	11.15	11.33	11.37	11.56	11.50	10.89
	H	1.24	1.48	1.79	2.20	2.64	2.93	3.29	3.48	3.68	3.72	3.90	3.87	3.21
8	D _b	9.78	10.08	10.45	10.94	11.22	11.51	11.88	12.03	12.22	12.30	12.44	12.43	11.82
	H	1.27	1.52	1.82	2.25	2.50	2.76	3.12	3.26	3.46	3.52	3.66	3.65	3.06
9	D _b	10.85	11.15	11.54	11.90	12.17	12.42	12.76	12.96	13.15	13.20	13.38	13.33	12.74
	H	1.31	1.55	1.86	2.18	2.41	2.63	2.93	3.12	3.30	3.36	3.53	3.48	2.92
10	D _b	11.89	12.23	12.58	12.87	13.10	13.36	13.68	13.86	14.13	14.14	14.34	14.25	13.67
	H	1.33	1.59	1.87	2.12	2.31	2.54	2.82	2.97	3.22	3.22	3.42	3.34	2.81

TABLE V B-3
 MANUAL SPINNING LIMITS
 17-7 PH
 (MILL-ANNEALED, CONDITION "A")

Gage (t)		.016	.020	.025	.032	.040	.050	.063	.071	.080	.090	.100	.125	.187
Die Diameter (D _d)	Flange Height (H): Blank Diameter (D _b)													
1	D _b	1.52	1.50	1.53										
	H	.42	.42	.43										
2	D _b	2.90	3.04	3.03	3.04	3.04	3.07							
	H	.71	.85	.85	.85	.85	.86							
3	D _b	4.05	4.13	4.21	4.34	4.44	4.52							
	H	.80	.87	.94	1.06	1.15	1.23							
4	D _b	4.99	5.07	5.15	5.27	5.37	5.47	5.57	5.66	5.73	5.80	5.85	5.96	6.18
	H	.72	.79	.85	.95	1.04	1.13	1.23	1.30	1.36	1.42	1.47	1.58	1.79
5	D _b	5.94	6.03	6.10	6.21	6.31	6.41	6.52	6.61	6.65	6.74	6.80	6.90	7.12
	H	.67	.73	.79	.87	.95	1.04	1.13	1.21	1.24	1.32	1.37	1.46	1.65
6	D _b	6.93	7.00	7.08	7.18	7.27	7.35	7.47	7.55	7.61	7.68	7.74	7.84	8.07
	H	.64	.70	.75	.83	.90	.97	1.07	1.13	1.18	1.24	1.28	1.37	1.57
7	D _b	7.90	7.97	8.04	8.12	8.23	8.31	8.44	8.51	8.57	8.64	8.69	8.79	9.01
	H	.61	.67	.72	.78	.86	.92	1.02	1.08	1.12	1.18	1.22	1.30	1.49
8	D _b	8.86	8.95	9.00	9.10	9.20	9.27	9.40	9.46	9.54	9.59	9.66	9.75	9.97
	H	.58	.65	.69	.76	.83	.88	.98	1.03	1.08	1.13	1.19	1.25	1.43
9	D _b	9.84	9.92	9.98	10.08	10.17	10.25	10.36	10.42	10.50	10.56	10.62	10.70	10.93
	H	.56	.63	.66	.74	.80	.86	.94	.99	1.05	1.09	1.13	1.20	1.37
10	D _b	10.83	10.91	10.95	11.04	11.13	11.23	11.32	11.40	11.46	11.51	11.58	11.69	11.89
	H	.55	.61	.64	.71	.77	.84	.90	.96	1.01	1.05	1.09	1.18	1.33

TABLE V B-4
 MANUAL SPINNING LIMITS
 PH 15-7 Mo
 (MILL ANNEALED, CONDITION "A")

Gage (t)	.016	.020	.025	.032	.040	.050	.063	.071	.080	.090	.100	.125	.187	
Die Diameter (D _d)	Flange Height (H): Blank Diameter (D _b)													
1	D _b	1.47	1.47											
	H	.38	.38											
2	D _b	2.97	2.97	2.97	2.97	2.97	2.97							
	H	.78	.78	.78	.78	.78	.78							
3	D _b	4.09	4.12	4.16	4.19	4.22	4.27	4.30	4.33	4.35	4.35	4.35	4.35	4.35
	H	.83	.86	.90	.92	.95	.99	1.02	1.05	1.06	1.06	1.06	1.06	1.06
4	D _b	5.07	5.10	5.14	5.17	5.21	5.25	5.28	5.31	5.33	5.36	5.38	5.41	5.51
	H	.79	.81	.84	.86	.90	.93	.96	.98	1.00	1.03	1.05	1.08	1.17
5	D _b	6.06	6.08	6.12	6.16	6.19	6.23	6.26	6.29	6.31	6.34	6.35	6.40	6.87
	H	.76	.78	.80	.83	.85	.89	.92	.94	.95	.98	.99	1.03	1.43
6	D _b	7.05	7.07	7.11	7.15	7.18	7.22	7.25	7.27	7.30	7.32	7.34	7.38	7.85
	H	.73	.74	.77	.80	.83	.87	.89	.90	.93	.94	.96	.99	1.38
7	D _b	8.04	8.06	8.10	8.13	8.16	8.21	8.24	8.26	8.29	8.31	8.33	8.37	8.84
	H	.72	.74	.76	.79	.81	.84	.87	.89	.91	.92	.94	.97	1.34
8	D _b	9.03	9.05	9.09	9.12	9.15	9.20	9.23	9.25	9.27	9.30	9.32	9.36	9.83
	H	.70	.72	.75	.77	.80	.83	.85	.86	.88	.91	.93	.96	1.31
9	D _b	10.02	10.04	10.08	10.11	10.14	10.19	10.22	10.24	10.26	10.29	10.31	10.35	10.81
	H	.69	.71	.74	.76	.79	.82	.84	.85	.87	.89	.91	.93	1.28
10	D _b	11.01	11.03	11.07	11.10	11.13	11.18	11.21	11.23	11.25	11.28	11.30	11.34	11.80
	H	.68	.70	.73	.75	.77	.80	.82	.84	.86	.87	.88	.92	1.27

ASD TR 61-191(II)

V-43

TABLE V B-6
 MANUAL SPINNING LIMITS
 A-286 STAINLESS STEEL
 (SOLUTION TREATED CONDITION)

Gage (t)		.016	.020	.025	.032	.040	.050	.063	.071	.080	.090	.100	.125	.187
Die Diameter (D _d)		Flange Height (H): Blank Diameter (D _b)												
1	D _b	2.00	2.00	2.00	2.00	2.00	2.00							
	H	.97	.97	.97	.97	.97	.97							
2	D _b	3.34	3.57	3.88	4.00	4.00	4.00							
	H	1.16	1.41	1.78	1.94	1.94	1.94							
3	D _b	4.47	4.73	5.06	5.50	5.87	6.00	6.00	6.00					
	H	1.18	1.44	1.79	2.30	2.74	2.92	2.92	2.92					
4	D _b	5.59	5.87	6.21	6.65	6.80	6.94	7.11	7.20	7.26	7.36	7.43	7.65	7.92
	H	1.25	1.49	1.82	2.27	2.44	2.60	2.80	2.89	2.97	3.09	3.17	3.43	3.78
5	D _b	6.69	6.99	7.34	7.61	7.74	7.89	8.05	8.14	8.22	8.31	8.40	8.58	8.92
	H	1.28	1.54	1.87	2.13	2.25	2.40	2.58	2.66	2.74	2.84	2.95	3.04	3.52
6	D _b	7.78	8.08	8.39	8.55	8.69	8.83	8.99	9.08	9.15	9.26	9.34	9.50	9.85
	H	1.32	1.57	1.85	2.00	2.13	2.26	2.41	2.51	2.57	2.67	2.75	2.92	3.29
7	D _b	8.86	9.17	9.34	9.51	9.64	9.79	9.94	10.02	10.10	10.21	10.28	10.45	10.81
	H	1.36	1.61	1.78	1.92	2.02	2.09	2.30	2.38	2.44	2.55	2.62	2.79	3.12
8	D _b	9.93	10.19	10.31	10.47	10.59	10.75	10.90	10.98	11.05	11.15	11.24	11.40	11.78
	H	1.39	1.60	1.71	1.83	1.94	2.08	2.21	2.28	2.33	2.44	2.52	2.65	3.02
9	D _b	11.01	11.15	11.28	11.43	11.56	11.71	11.86	11.94	12.02	12.12	12.20	12.35	12.73
	H	1.44	1.55	1.66	1.78	1.89	2.01	2.14	2.20	2.27	2.37	2.43	2.57	2.91
10	D _b	12.03	12.12	12.24	12.41	12.53	12.68	12.81	12.88	12.99	13.08	13.18	13.32	13.67
	H	1.42	1.51	1.60	1.75	1.84	1.95	2.07	2.13	2.21	2.30	2.37	2.48	2.82

ASD TR 61-191(II)

V-45

TABLE V B-7
 MANUAL SPINNING LIMITS
 USS-12-MoV STAINLESS STEEL
 (ANNEALED)

Gage (t)		.016	.020	.025	.032	.040	.050	.063	.071	.080	.090	.100	.125	.187
Die Diameter (D _d)	Flange Height (H): Blank Diameter (D _b)													
1	D _b	1.59	1.59	1.59										
	H	.50	.50	.50										
2	D _b	3.15	3.18	3.18	3.18	3.18	3.18							
	H	.95	.99	.99	.99	.99	.99							
3	D _b	4.26	4.48	4.76	4.76	4.76	4.76	4.76	4.76	4.76				
	H	.98	1.19	1.47	1.47	1.47	1.47	1.47	1.47	1.47				
4	D _b	5.37	5.60	5.89	6.29	6.37	6.37	6.37	6.37	6.37	6.37	6.37	6.37	6.37
	H	1.04	1.24	1.51	1.90	1.98	1.98	1.98	1.98	1.98	1.98	1.98	1.98	1.98
5	D _b	6.45	6.67	6.94	7.42	7.62	7.75	7.90	7.94	7.94	7.94	7.94	7.94	7.94
	H	1.07	1.26	1.50	1.93	2.13	2.27	2.42	2.46	2.46	2.46	2.46	2.46	2.95
6	D _b	7.53	7.79	8.11	8.49	8.58	8.70	8.85	8.94	9.02	9.10	9.20	9.35	9.51
	H	1.12	1.33	1.61	1.92	2.03	2.13	2.28	2.37	2.44	2.53	2.62	2.76	2.93
7	D _b	8.60	8.91	9.21	9.44	9.54	9.66	9.80	9.88	9.97	10.06	10.14	10.30	10.66
	H	1.15	1.39	1.65	1.85	1.94	2.05	2.10	2.25	2.33	2.42	2.48	2.64	2.98
8	D _b	9.67	9.95	10.21	10.41	10.50	10.62	10.76	10.84	10.93	11.01	11.10	11.25	11.61
	H	1.20	1.41	1.61	1.78	1.87	1.96	2.09	2.16	2.24	2.31	2.39	2.53	2.87
9	D _b	10.72	11.02	11.19	11.38	11.48	11.58	11.72	11.81	11.88	11.97	12.06	12.20	12.57
	H	1.22	1.45	1.57	1.74	1.82	1.91	2.02	2.10	2.16	2.23	2.31	2.43	2.76
10	D _b	11.78	12.03	12.15	12.35	12.43	12.55	12.68	12.77	12.85	12.94	13.02	13.17	13.53
	H	1.25	1.42	1.52	1.68	1.76	1.85	1.95	2.04	2.10	2.18	2.24	2.36	2.68

ASD TR 61-191(II)

V-46

TABLE V B-8
 MANUAL SPINNING LIMITS
 TITANIUM (6 Al-4V)
 (MILL ANNEALED)

Gage (t)		.016	.020	.025	.032	.040	.050	.063	.071	.080	.090	.100	.125	.187
Die Diameter (D _d)		Flange Height (H): Blank Diameter (D _b)												
1	D _b	1.28	1.28	1.28										
	H	.21	.21	.21										
2	D _b	2.36	2.44	2.54	2.64	2.64	2.64	2.64						
	H	.25	.31	.40	.47	.47	.47	.47						
3	D _b	3.44	3.51	3.54	3.57	3.60	3.63	3.66	3.68	3.70	3.72	3.74	3.77	3.84
	H	.30	.36	.37	.41	.43	.45	.47	.49	.51	.52	.54	.56	.61
4	D _b	4.46	4.50	4.53	4.55	4.58	4.61	4.64	4.66	4.68	4.69	4.71	4.75	4.82
	H	.32	.34	.36	.38	.40	.42	.44	.46	.48	.49	.50	.53	.58
5	D _b	5.46	5.49	5.52	5.54	5.57	5.59	5.63	5.64	5.66	5.67	5.70	5.73	5.80
	H	.31	.33	.35	.37	.39	.41	.43	.44	.45	.46	.48	.50	.56
6	D _b		6.48	6.51	6.53	6.55	6.58	6.61	6.63	6.65	6.66	6.68	6.72	6.79
	H		.32	.34	.35	.37	.39	.41	.43	.44	.45	.46	.49	.54
7	D _b							7.60	7.61	7.63	7.65	7.67	7.71	7.78
	H							.40	.41	.42	.44	.45	.48	.53
8	D _b													
	H													
9	D _b													
	H													
10	D _b													
	H													

TABLE V B-9
 MANUAL SPINNING LIMITS
 TITANIUM (13V-11Cr-3Al)
 (SOLUTION TREATED CONDITION)

Die Diameter		Flange Height (H) : Blank Diameter (D _b)											
Gage (t)													
1	H	1.19	1.20										
	D _b												
2	H	2.37	2.43	2.43									
	D _b												
3	H	3.38	3.41	3.43	3.45	3.47	3.49						
	D _b												
4	H	4.37	4.39	4.41	4.43	4.45	4.47	4.49	4.51	4.52	4.53	4.54	
	D _b												
5	H	5.36	5.38	5.40	5.42	5.44	5.46	5.48	5.50	5.51	5.52	5.53	5.57
	D _b												
6	H	6.35	6.37	6.39	6.41	6.43	6.45	6.47	6.50	6.51	6.52	6.56	6.62
	D _b												
7	H	7.34	7.36	7.38	7.40	7.42	7.44	7.46	7.48	7.50	7.51	7.52	7.55
	D _b												
8	H	8.34	8.36	8.38	8.40	8.42	8.44	8.46	8.48	8.49	8.50	8.51	8.54
	D _b												
9	H	9.34	9.36	9.38	9.40	9.42	9.44	9.46	9.47	9.49	9.50	9.51	9.53
	D _b												
10	H	10.33	10.35	10.37	10.39	10.41	10.43	10.45	10.47	10.48	10.49	10.50	10.52
	D _b												

TABLE V B-10
 MANUAL SPINNING LIMITS
 VASCOJET 1000 (H-11)
 (ANNEALED)

Gage (t)		.016	.020	.025	.032	.040	.050	.063	.071	.080	.090	.100	.125	.187
Die Diameter (D _d)	Flange Height (H): Blank Diameter (D _b)													
1	D _b	1.675	1.675	1.675										
	H	.58	.58	.58										
2	D _b	2.884	3.04	3.235	3.35	3.35	3.35							
	H	.69	.85	1.05	1.17	1.17	1.17							
3	D _b	3.98	4.15	4.36	4.64	4.94	5.00	5.00	5.00	5.00	5.00	5.00	5.00	
	H	.74	.89	1.07	1.35	1.66	1.72	1.72	1.72	1.72	1.72	1.72	1.72	
4	D _b	5.065	5.24	5.465	5.70	6.08	6.47	6.58	6.67	6.70	6.70	6.70	6.70	6.70
	H	.79	.92	1.12	1.33	1.69	2.10	2.20	2.30	2.33	2.33	2.33	2.33	2.33
5	D _b	6.13	6.32	6.56	6.87	7.19	7.43	7.55	7.63	7.69	7.76	7.82	7.95	8.24
	H	.81	.96	1.16	1.43	1.72	1.94	2.08	2.14	2.21	2.28	2.33	2.46	2.76
6	D _b	7.185	7.375	7.63	7.96	8.28	8.40	8.51	8.58	8.66	8.72	8.78	8.90	9.20
	H	.83	.99	1.20	1.46	1.75	1.86	1.96	2.03	2.10	2.15	2.21	2.33	2.62
7	D _b	8.24	8.44	8.71	9.05	9.26	9.37	9.48	9.55	9.62	9.70	9.74	9.87	10.15
	H	.87	1.02	1.24	1.51	1.69	1.80	1.89	1.94	2.00	2.05	2.07	2.23	2.49
8	D _b	9.29	9.50	9.775	10.12	10.22	10.33	10.45	10.53	10.59	10.66	10.72	10.85	11.12
	H	.90	1.06	1.27	1.54	1.62	1.72	1.82	1.89	1.94	2.00	2.05	2.17	2.41
9	D _b	10.345	10.56	10.84	11.09	11.20	11.30	11.42	11.50	11.56	11.63	11.68	11.82	12.09
	H	.93	1.09	1.31	1.50	1.59	1.68	1.77	1.84	1.89	1.95	1.98	2.11	2.34
10	D _b	11.385	11.61	11.86	12.07	12.18	12.28	12.39	12.46	12.53	12.60	12.66	12.78	13.06
	H	.95	1.11	1.31	1.45	1.54	1.64	1.73	1.78	1.84	1.89	1.94	2.05	2.27

ASD TR 61-191(II)

V-49

TABLE V B-11
 MANUAL SPINNING LIMITS
 BERYLLIUM (PURE)
 CONDITION "C", TEMP. 1200°F

Gage (t)		.016	.020	.025	.032	.040	.050	.063	.071	.080	.090	.100	.125	.187
Die Diameter (D _d)	Flange Height (H): Blank Diameter (D _b)													
1	D _b	1.13	1.17	1.19	1.20	1.20	1.20							
	H	.09	.12	.13	.14	.14	.14							
2	D _b	2.18	2.21	2.24	2.29	2.33	2.39	2.41	2.41	2.41	2.41	2.41	2.41	2.41
	H	.12	.14	.16	.19	.23	.27	.29	.29	.29	.29	.29	.29	.29
3	D _b			3.27	3.32	3.38	3.43	3.51	3.54	3.55	3.57	3.58	3.61	
	H			.18	.22	.26	.30	.36	.37	.38	.41	.42	.44	
4	D _b				4.35	4.41	4.48	4.51	4.53	4.54	4.55	4.56	4.59	
	H				.23	.28	.33	.35	.36	.37	.38	.39	.41	
5	D _b						5.48	5.49	5.51	5.53	5.54	5.55	5.58	
	H						.33	.34	.35	.36	.37	.38	.39	
6	D _b						6.48	6.49	6.50	6.52	6.53	6.55	6.58	
	H						.32	.33	.34	.35	.36	.37	.38	
7	D _b										7.53	7.55	7.58	
	H										.35	.37	.38	
8	D _b											8.54	8.58	
	H											.37	.38	
9	D _b													
	H													
10	D _b													
	H													

TABLE V B-12
 MANUAL SPINNING LIMITS
 RENE '41
 (SOLUTION TREATED)

Gage (t)		.016	.020	.025	.032	.040	.050	.063	.071	.080	.090	.100	.125	.187
Die Diameter (D _d)		Flange Height (H): Blank Diameter (D _b)												
1	D _b	1.52	1.52	1.52										
	H	.42	.42	.42										
2	D _b	3.03	3.04	3.04	3.04	3.04	3.04							
	H	.85	.85	.85	.85	.85	.85							
3	D _b	4.15	4.25	4.31	4.39	4.46	4.54	4.54	4.54	4.54	4.54	4.54	4.54	
	H	.89	.98	1.03	1.10	1.17	1.25	1.25	1.25	1.25	1.25	1.25	1.25	
4	D _b	5.18	5.22	5.29	.536	.542	5.50	5.59	5.63	5.66	5.71	5.74	5.84	6.01
	H	.87	.91	.99	1.03	1.09	1.16	1.25	1.28	1.30	1.34	1.37	1.46	1.63
5	D _b	6.15	6.20	6.26	6.33	6.40	6.46	6.55	6.60	6.63	6.68	6.71	6.80	6.97
	H	.83	.86	.91	.97	1.03	1.08	1.16	1.20	1.23	1.27	1.31	1.37	1.52
6	D _b	7.13	7.18	7.23	7.31	7.38	7.44	7.53	7.57	7.60	7.65	7.68	7.77	7.94
	H	.79	.83	.87	.93	.99	1.05	1.11	1.15	1.17	1.21	1.24	1.31	1.45
7	D _b	8.11	8.16	8.21	8.29	8.36	8.42	8.50	8.55	8.58	8.62	8.66	8.74	8.91
	H	.77	.81	.84	.90	.96	1.00	1.07	1.10	1.13	1.16	1.20	1.26	1.40
8	D _b	9.09	9.14	9.20	9.27	9.34	9.40	9.48	9.52	9.56	9.60	9.64	9.72	9.89
	H	.75	.79	.83	.88	.93	.98	1.04	1.06	1.10	1.14	1.17	1.23	1.36
9	D _b	10.08	10.13	10.18	10.25	10.32	10.38	10.46	10.50	10.54	10.58	10.62	10.70	10.86
	H	.74	.78	.81	.86	.91	.96	1.02	1.05	1.08	1.11	1.13	1.20	1.33
10	D _b	11.07	11.11	11.16	11.24	11.30	11.37	11.45	11.49	11.52	11.56	11.60	11.68	11.84
	H	.73	.76	.79	.85	.88	.94	1.00	1.04	1.06	1.07	1.12	1.18	1.31

TABLE V B-13
 MANUAL SPINNING LIMITS
 INCONEL X
 (C.R. ANNEALED)

Gage (t)		.016	.020	.025	.032	.040	.050	.063	.071	.080	.090	.100	.125	.187
Die Diameter (D _d)	Flange Height (H): Blank Diameter (D _b)													
1	D _b	1.76	1.76	1.76										
	H	.68	.68	.68										
2	D _b	3.10	3.30	3.52	3.52	3.52	3.52							
	H	.91	1.11	1.35	1.35	1.35	1.35							
3	D _b	4.21	4.44	4.70	5.06	5.24	5.26	5.26	5.26	5.26	.526	.526	5.26	5.26
	H	.94	1.15	1.41	1.79	1.99	2.01	2.01	2.01	2.01	2.01	2.01	2.01	2.01
4	D _b	5.31	5.55	5.82	6.10	6.22	6.35	6.47	6.54	6.62	6.70	6.78	6.95	6.99
	H	.98	1.21	1.43	1.71	1.83	1.96	2.09	2.16	2.24	2.33	2.42	2.61	2.66
5	D _b	6.40	6.65	6.94	7.05	7.17	7.30	7.42	7.50	7.56	7.65	7.72	7.90	8.19
	H	1.03	1.24	1.49	1.60	1.71	1.83	1.94	2.01	2.09	2.17	2.23	2.41	2.71
6	D _b	7.47	7.73	7.90	8.01	8.14	8.26	8.37	8.46	8.51	8.61	8.68	8.85	9.14
	H	1.06	1.28	1.43	1.52	1.63	1.73	1.83	1.91	1.96	2.05	2.12	2.28	2.56
7	D _b	8.54	8.76	8.86	8.98	9.10	9.22	9.33	9.42	9.48	9.56	9.64	9.80	10.10
	H	1.10	1.27	1.36	1.46	1.55	1.65	1.75	1.84	1.89	1.95	2.02	2.10	2.44
8	D _b	9.61	9.73	9.83	9.95	10.06	10.19	10.30	10.38	10.45	10.54	10.62	10.75	11.06
	H	1.14	1.24	1.31	1.41	1.50	1.60	1.70	1.76	1.84	1.90	1.96	2.08	2.34
9	D _b	10.61	10.71	10.80	10.92	11.03	11.16	11.27	11.34	11.42	11.51	11.58	11.70	12.01
	H	1.13	1.21	1.28	1.37	1.46	1.56	1.65	1.71	1.77	1.85	1.91	2.00	2.26
10	D _b	11.59	11.68	11.78	11.90	12.0	12.12	12.25	12.32	12.39	12.47	12.54	12.67	12.98
	H	1.11	1.18	1.25	1.34	1.42	1.51	1.61	1.67	1.73	1.79	1.85	1.95	2.20

TABLE V B-14
 MANUAL SPINNING LIMITS
 HASTELLOY X
 (SOLUTION TREATED)

Gage (t)		.016	.020	.025	.032	.040	.050	.063	.071	.080	.090	.100	.125	.187
Die Diameter (D _d)		Flange Height (H): Blank Diameter (D _b)												
1	D _b	1.68	1.68	1.68										
	H	.58	.58	.58										
2	D _b	3.15	3.36	3.36	3.36	3.36	3.36							
	H	.95	1.18	1.18	1.18	1.18	1.18							
3	D _b	4.28	4.49	4.75	4.87	5.00	5.00	5.00	5.00	5.00	5.00	5.00		
	H	1.00	1.20	1.46	1.58	1.72	1.72	1.72	1.72	1.72	1.72	1.72		
4	D _b	5.38	5.65	5.71	5.83	5.94	6.06	6.17	6.26	6.30	6.40	6.46	6.60	6.65
	H	1.05	1.29	1.34	1.45	1.56	1.66	1.78	1.87	1.91	2.01	2.08	2.22	2.28
5	D _b	6.47	6.59	6.68	6.80	6.90	7.02	7.13	7.22	7.26	7.36	7.42	7.55	7.80
	H	1.09	1.18	1.28	1.37	1.46	1.58	1.66	1.75	1.79	1.89	1.93	2.08	2.31
6	D _b	7.50	7.56	7.65	7.77	7.87	7.98	8.09	8.17	8.22	8.32	8.38	8.50	8.77
	H	1.09	1.14	1.21	1.31	1.40	1.49	1.59	1.65	1.70	1.79	1.84	1.95	2.20
7	D _b	8.46	8.54	8.62	8.74	8.84	8.95	9.07	9.14	9.19	9.29	9.34	9.47	9.73
	H	1.04	1.10	1.17	1.25	1.34	1.43	1.53	1.58	1.62	1.71	1.76	1.84	2.06
8	D _b	9.44	9.52	9.60	9.71	9.81	9.93	10.04	10.12	10.16	10.25	10.32	10.43	10.69
	H	1.01	1.06	1.14	1.22	1.30	1.40	1.49	1.54	1.58	1.65	1.72	1.82	2.03
9	D _b	10.42	10.50	10.58	10.69	10.79	10.91	11.00	11.09	11.13	11.22	11.28	11.40	11.66
	H	.99	1.05	1.11	1.19	1.27	1.35	1.43	1.51	1.54	1.59	1.66	1.75	1.96
10	D _b	11.40	11.48	11.56	11.67	11.77	11.89	11.99	12.07	12.11	12.20	12.26	12.38	12.63
	H	.96	1.03	1.07	1.16	1.24	1.33	1.41	1.45	1.50	1.56	1.62	1.72	1.92

TABLE V B-15
 MANUAL SPINNING LIMITS
 L-605
 (SOLUTION TREATED)

Gage (t)		.016	.020	.025	.032	.040	.050	.063	.071	.080	.090	.100	.125	.187
Die Diameter (D _d)	Flange Height (H): Blank Diameter (D _b)													
1	D _b	1.60	1.60	1.60										
	H	.51	.51	.51										
2	D _b	3.20	3.20	3.20	3.20	3.20	3.20							
	H	1.00	1.00	1.00	1.00	1.00	1.00							
3	D _b	4.31	4.38	4.46	4.54	4.62	4.70	4.76	4.76	4.76				
	H	1.03	1.09	1.17	1.25	1.33	1.41	1.47	1.47	1.47				
4	D _b	5.28	5.34	5.42	5.49	5.58	5.66	5.74	5.80	5.84	5.89	5.94	6.05	6.24
	H	.96	1.01	1.09	1.14	1.24	1.30	1.37	1.41	1.45	1.51	1.56	1.66	1.85
5	D _b	6.25	6.31	6.39	6.47	6.55	6.62	6.70	6.76	6.81	6.85	6.91	7.01	7.20
	H	.91	.95	1.02	1.09	1.15	1.22	1.29	1.34	1.38	1.42	1.47	1.56	1.74
6	D _b	7.23	7.29	7.36	7.44	7.53	7.59	7.68	7.73	7.78	7.82	7.88	7.97	8.17
	H	.87	.92	.98	1.05	1.12	1.16	1.24	1.28	1.32	1.35	1.41	1.47	1.65
7	D _b	8.21	8.27	8.34	8.42	8.50	8.57	8.65	8.70	8.75	8.80	8.85	8.94	9.14
	H	.85	.89	.94	1.00	1.07	1.12	1.19	1.23	1.26	1.31	1.35	1.43	1.59
8	D _b	9.19	9.25	9.32	9.40	9.48	9.55	9.63	9.68	9.72	9.77	9.82	9.91	10.11
	H	.82	.86	.92	.98	1.04	1.09	1.15	1.21	1.24	1.26	1.30	1.37	1.53
9	D _b	10.17	10.23	10.30	10.38	10.46	10.53	10.61	10.66	10.69	10.75	10.80	10.89	11.09
	H	.80	.84	.90	.96	1.02	1.08	1.13	1.16	1.19	1.24	1.28	1.36	1.50
10	D _b	11.16	11.22	11.29	11.36	11.44	11.51	11.60	11.64	11.68	11.73	11.78	11.87	12.06
	H	.78	.83	.89	.93	.99	1.05	1.12	1.15	1.18	1.21	1.25	1.31	1.44

TABLE V B-16
 MANUAL SPINNING LIMITS
 J-1570
 (SOLUTION TREATED)

Gage (t)	.016	.020	.025	.032	.040	.050	.063	.071	.080	.090	.100	.125	.187	
Die Diameter (D_d)	Flange Height (H): Blank Diameter (D_b)													
1	D_b	1.55	1.55	1.55										
	H	.45	.45	.45										
2	D_b	3.08	3.08	3.08	3.08	3.08								
	H	.87	.87	.87	.87	.87								
3	D_b	4.21	4.32	4.38	4.45	4.53	4.60							
	H	.94	1.04	1.10	1.16	1.24	1.31							
4	D_b	5.22	5.29	5.34	5.42	5.50	5.56	5.64	5.69	5.75	5.78	5.81	5.93	6.13
	H	.91	.97	1.00	1.08	1.15	1.22	1.28	1.32	1.38	1.40	1.43	1.55	1.74
5	D_b	6.20	6.27	6.32	6.39	6.47	6.53	6.62	6.66	6.71	6.74	6.78	6.90	7.10
	H	.88	.92	.96	1.02	1.09	1.14	1.22	1.25	1.29	1.32	1.35	1.46	1.63
6	D_b	7.18	7.25	7.30	7.37	7.45	7.51	7.59	7.63	7.68	7.71	7.75	7.86	8.06
	H	.83	.88	.93	.99	1.05	1.10	1.17	1.20	1.24	1.26	1.29	1.39	1.56
7	D_b	8.16	8.23	8.28	8.35	8.42	8.49	8.56	8.60	8.65	8.69	8.72	8.83	9.03
	H	.81	.86	.90	.95	1.00	1.07	1.11	1.15	1.19	1.22	1.25	1.33	1.51
8	D_b	9.14	9.20	9.26	9.33	9.40	9.47	9.52	9.59	9.63	9.67	9.70	9.81	10.01
	H	.79	.83	.87	.93	.98	1.04	1.06	1.13	1.16	1.20	1.22	1.29	1.46
9	D_b	10.13	10.19	10.24	10.31	10.38	10.45	10.51	10.57	10.61	10.65	10.68	10.79	10.99
	H	.77	.81	.85	.91	.96	1.01	1.06	1.10	1.13	1.15	1.18	1.27	1.43
10	D_b	11.12	11.18	11.23	11.29	11.37	11.43	11.50	11.55	11.60	11.64	11.67	11.77	11.97
	H	.76	.80	.84	.89	.94	.98	1.04	1.07	1.11	1.15	1.16	1.24	1.40

TABLE V B-17
 MANUAL SPINNING LIMITS
 COLUMBIUM (10 Mo-10 Ti)

Gage (t)		.016	.020	.025	.032	.040	.050	.063	.071	.080	.090	.100	.125	.187
Die Diameter (D_d)	Flange Height (H): Blank Diameter (D_b)													
1	D_b	1.33	1.33											
	H	.26	.26											
2	D_b	2.47	2.55	2.65	2.65	2.65	2.65	2.65	2.65	2.65	2.65	2.65		
	H	.34	.40	.48	.48	.48	.48	.48	.48	.48	.48	.48		
3	D_b	3.53	3.62	3.69	3.72	3.77	3.81	3.84	3.88	3.90	3.92	3.95	3.97	3.97
	H	.36	.44	.50	.52	.56	.60	.61	.65	.66	.68	.71	.74	.74
4	D_b	4.57	4.64	4.67	4.70	4.75	4.79	4.82	4.86	4.88	4.90	4.93	4.97	5.06
	H	.39	.44	.47	.49	.53	.56	.58	.62	.64	.65	.66	.70	.79
5	D_b	5.59	5.62	5.66	5.69	5.73	5.77	5.81	5.84	5.86	5.88	5.90	5.95	6.03
	H	.41	.42	.45	.47	.50	.55	.57	.59	.60	.62	.63	.68	.73
6	D_b	6.58	6.61	6.65	6.68	6.72	6.75	6.79	6.82	6.84	6.86	6.88	6.93	7.02
	H	.40	.41	.44	.46	.49	.51	.54	.57	.58	.59	.61	.64	.72
7	D_b				7.67	7.71	7.74	7.78	7.81	7.82	7.84	7.87	7.91	8.00
	H				.45	.48	.50	.53	.55	.56	.57	.60	.62	.70
8	D_b				8.65	8.70	8.73	8.77	8.80	8.81	8.83	8.86	8.90	8.99
	H				.44	.47	.49	.52	.54	.55	.57	.58	.61	.68
9	D_b							9.76	9.78	9.80	9.82	9.85	9.89	9.98
	H							.51	.52	.53	.54	.57	.61	.66
10	D_b							10.75	10.77	10.79	10.81	10.83	10.88	10.97
	H							.50	.52	.53	.54	.55	.59	.66

TABLE V B-18
 MANUAL SPINNING LIMITS
 MOLYBDENUM (.5% Ti)
 (HOT ROLLED, STRESS RELIEVED, DE-SCALED SHEET)
 TEMPERATURE 850°F

Gage (t)	.016	.020	.025	.032	.040	.050	.063	.071	.080	.090	.100	.125	.187
Die Diameter (D _d)	Flange Height (H): Blank Diameter (D _b)												
1	D _b	1.66	1.68	1.68									
	H	.57	.58	.58									
2	D _b	2.78	2.92	3.09	3.32	3.35	3.35						
	H	.60	.73	.90	1.13	1.17	1.17						
3	D _b	3.87	4.03	4.20	4.45	4.60	5.01	5.01	5.01				
	H	.64	.78	.93	1.16	1.31	1.73	1.73	1.73				
4	D _b	4.94	5.11	5.30	5.57	5.74	6.18	6.56	6.63	6.70	6.70	6.70	6.70
	H	.67	.82	.97	1.23	1.37	1.79	2.17	2.25	2.33	2.33	2.33	2.33
5	D _b	6.00	6.17	6.38	6.66	6.84	7.30	7.52	7.59	7.66	7.72	7.80	7.83
	H	.71	.84	1.02	1.25	1.41	1.83	2.03	2.11	2.18	2.23	2.31	2.45
6	D _b	7.03	7.21	7.44	7.73	7.94	8.36	8.48	8.55	8.61	8.68	8.76	8.88
	H	.72	.85	1.05	1.28	1.44	1.82	1.92	2.00	2.05	2.12	1.19	2.31
7	D _b	8.08	8.27	8.51	8.82	9.03	9.33	9.45	9.52	9.58	9.65	9.72	9.83
	H	.75	.89	1.08	1.33	1.51	1.75	1.86	1.92	1.97	2.04	2.07	2.20
8	D _b	9.13	9.33	9.57	9.88	10.13	10.30	10.42	10.49	10.54	10.61	10.68	10.80
	H	.78	.93	1.11	1.35	1.55	1.70	1.79	1.86	1.90	1.95	2.02	2.12
9	D _b	10.18	10.38	10.62	10.95	11.16	11.27	11.38	11.46	11.51	11.57	11.64	11.78
	H	.81	.96	1.14	1.40	1.56	1.65	1.74	1.80	1.85	1.90	1.96	2.07
10	D _b	11.22	11.43	11.66	12.00	12.14	12.24	12.36	12.43	12.49	12.54	12.62	12.75
	H	.83	.99	1.16	1.42	1.51	1.60	1.69	1.76	1.81	1.84	1.91	2.02

ASD TR 61-191(II)

V-57

TABLE V B-19
 MANUAL SPINNING LIMITS
 TUNGSTEN (PURE)
 TEMPERATURE 1700°F

Gage (t)	.016	.020	.025	.032	.040	.050	.063	.071	.080	.090	.100	.125	.187	
Die Diameter (D _d)	Flange Height (H): Blank Diameter (D _b)													
1	D _b	1.42	1.47	1.47	1.47									
	H	.33	.38	.38	.38									
2	D _b	2.35	2.47	2.63	2.84	2.94	2.94	2.94	2.94	2.94				
	H	.25	.34	.46	.66	.74	.74	.74	.74	.74				
3	D _b	3.31	3.41	3.56	3.76	4.02	4.06	4.12	4.15	4.18	4.22	4.25	4.32	4.40
	H	.21	.28	.40	.55	.77	.81	.86	.89	.91	.93	.95	1.04	1.11
4	D _b	4.28	4.38	4.53	4.69	4.94	5.03	5.10	5.12	5.15	5.19	5.22	5.28	5.42
	H	.18	.25	.36	.48	.67	.75	.81	.83	.85	.88	.93	.96	1.09
5	D _b		5.35	5.47	5.65	5.87	6.01	6.07	6.09	6.13	6.16	6.19	6.25	6.39
	H		.23	.32	.45	.61	.71	.76	.78	.81	.83	.85	.90	1.02
6	D _b				6.62	6.83	6.99	7.05	7.07	7.11	7.14	7.17	7.23	7.37
	H				.42	.58	.69	.72	.74	.77	.80	.82	.88	.99
7	D _b				7.59	7.79	7.98	8.04	8.06	8.09	8.12	8.15	8.21	8.35
	H				.39	.54	.68	.72	.74	.76	.78	.80	.84	.95
8	D _b				8.57	8.75	8.97	9.02	9.05	9.07	9.10	9.13	9.19	9.33
	H				.38	.51	.67	.71	.73	.74	.76	.78	.82	.93
9	D _b					9.73	9.96	10.01	10.04	10.06	10.09	10.12	10.18	10.31
	H					.49	.64	.68	.70	.71	.73	.77	.81	.90
10	D _b					10.72	10.94	11.00	11.03	11.05	11.08	11.11	11.17	11.30
	H					.49	.63	.68	.70	.72	.73	.75	.80	.88

TABLE V B-20
 MANUAL SPINNING LIMITS
 HM21XA-T8 (MAGNESIUM THORIUM)
 TEMPERATURE 750°F

Gage (t)		.016	.020	.025	.032	.040	.050	.063	.071	.080	.090	.100	.125	.187
Die Diameter (D _d)	Flange Height (H): Blank Diameter (D _b)													
1	D _b	2.71	3.07	3.50	3.58	3.58	3.58							
	H	2.05	2.72	3.62	3.82	3.82	3.82							
2	D _b	3.93	4.32	4.79	5.41	6.14	7.00	7.16	7.16					
	H	1.83	2.37	3.06	4.05	5.41	7.25	7.66	7.66					
3	D _b	5.10	5.51	6.00	6.65	7.40	8.30	9.45	10.19	10.80	10.80	10.80	10.80	10.80
	H	1.82	2.31	2.92	3.80	4.90	6.45	8.65	10.2	11.6	11.6	11.6	11.6	11.6
4	D _b	6.25	6.68	7.20	7.86	8.63	9.58	10.71	11.48	11.64	11.85	12.00	12.30	12.56
	H	1.85	2.31	2.89	3.74	4.76	6.11	7.99	9.35	9.60	10.1	10.3	10.9	11.4
5	D _b	7.38	7.82	8.35	9.05	9.82	10.80	11.96	12.46	12.55	12.76	12.90	13.22	13.48
	H	1.91	2.33	2.87	3.66	4.62	5.89	7.62	8.40	8.53	8.89	9.13	9.66	10.1
6	D _b	8.50	8.96	9.50	10.21	11.02	12.00	13.16	13.40	13.48	13.68	13.81	14.15	14.41
	H	1.95	2.39	2.92	3.69	4.60	5.80	7.35	7.73	7.85	8.10	8.31	8.80	9.22
7	D _b	9.60	10.08	10.64	11.37	12.27	13.20	14.09	14.34	14.42	14.62	14.73	15.08	15.34
	H	1.99	2.42	2.97	3.72	4.77	5.77	6.87	7.22	7.32	7.58	7.73	8.20	8.58
8	D _b	10.70	11.19	11.76	12.50	13.36	14.40	15.03	15.26	15.36	15.54	15.66	16.00	16.26
	H	2.03	2.47	3.01	3.71	4.61	5.75	6.47	6.65	6.85	7.13	7.31	7.73	8.07
9	D _b	11.79	12.29	12.86	13.64	14.51	15.54	15.96	16.19	16.31	16.49	16.62	16.95	17.19
	H	2.08	11.94	3.01	3.78	4.63	5.75	6.20	6.46	6.62	6.86	6.97	7.36	7.65
10	D _b	12.87	13.38	13.96	14.76	15.65	16.63	16.92	17.13	17.26	17.44	17.58	17.90	18.15
	H	2.12	2.56	3.06	3.78	4.66	5.67	5.99	6.24	6.35	6.55	6.75	7.10	7.38

TABLE V B-21
 MANUAL SPINNING LIMITS
 USS-12-MoV
 (ANNEALED)
 TEMPERATURE 750°F

Gage (t)		.016	.020	.025	.032	.040	.050	.063	.071	.080	.090	.100	.125	.187
Die Diameter (D _d)	Flange Height (H): Blank Diameter (D _b)													
1	D _b	1.90	1.92	1.92										
	H	.85	.87	.87										
2	D _b	3.05	3.24	3.46	3.79	3.92								
	H	.85	1.05	1.29	1.68	1.82								
3	D _b	4.16	4.36	4.61	4.95	5.30	5.74	5.78	5.78	5.78	5.78	5.78		
	H	.89	1.07	1.32	1.67	2.06	2.57	2.63	2.63	2.63	2.63	2.63		
4	D _b	5.25	5.47	5.72	6.11	6.47	6.93	7.16	7.30	7.40	7.50	7.60	7.68	7.68
	H	.93	1.12	1.35	1.72	2.09	2.58	2.84	3.02	3.13	3.25	3.38	3.46	3.46
5	D _b	6.33	6.56	6.84	7.22	7.59	7.92	8.10	8.21	8.33	8.42	8.52	8.75	9.19
	H	.96	1.16	1.40	1.75	2.12	2.43	2.62	2.73	2.86	2.97	3.08	3.33	3.85
6	D _b	7.40	7.64	7.93	8.32	8.67	8.86	9.04	9.14	9.26	9.35	9.44	9.68	10.11
	H	1.01	1.20	1.45	1.79	2.11	2.29	2.46	2.56	2.67	2.76	2.86	3.11	3.56
7	D _b	8.46	8.71	9.01	9.41	9.62	9.80	9.99	10.08	10.20	10.28	10.38	10.60	11.04
	H	1.04	1.24	1.49	1.83	2.00	2.10	2.35	2.42	2.54	2.62	2.71	2.93	3.43
8	D _b	9.49	9.77	10.09	10.42	10.57	10.76	10.93	11.02	11.14	11.22	11.32	11.55	11.97
	H	1.06	1.27	1.53	1.79	1.92	2.08	2.24	2.32	2.43	2.50	2.59	2.81	3.21
9	D _b	10.58	10.84	11.16	11.38	11.53	11.71	11.88	11.98	12.09	12.17	12.26	12.50	12.93
	H	1.10	1.30	1.56	1.74	1.85	2.01	2.16	2.24	2.33	2.41	2.48	2.70	3.00
10	D _b	11.62	11.91	12.19	12.35	12.49	12.67	12.83	12.94	13.04	13.13	13.22	13.45	13.89
	H	1.13	1.34	1.55	1.68	1.80	1.95	2.08	2.18	2.26	2.35	2.42	2.61	3.00

TABLE V B-22
 MANUAL SPINNING LIMITS
 VASCOJET 1000 (H-11)
 (ANNEALED)
 TEMPERATURE 750°F

Gage (t)		.016	.020	.025	.032	.040	.050	.063	.071	.080	.090	.100	.125	.187
Die Diameter (D _d)		Flange Height (H): Blank Diameter (D _b)												
1	D _b	1.68	1.73	1.73										
	H	.58	.64	.64										
2	D _b	2.81	2.96	3.13	3.37	3.47	3.47							
	H	.63	.77	.93	1.18	1.28	1.28							
3	D _b	3.90	4.05	4.25	4.57	4.77	5.10	5.16	5.16	5.16	5.16	5.16	5.16	
	H	.66	.80	.97	1.28	1.46	1.84	1.90	1.90	1.90	1.90	1.90	1.90	
4	D _b	4.97	5.12	5.34	5.62	5.91	6.05	6.16	6.23	6.29	6.38	6.42	6.57	6.84
	H	.70	.83	1.01	1.26	1.53	1.66	1.77	1.84	1.90	1.99	2.03	2.19	2.48
5	D _b	6.03	6.21	6.43	6.71	6.91	7.02	7.13	7.19	7.26	7.34	7.40	7.52	7.80
	H	.72	.87	1.06	1.29	1.47	1.58	1.66	1.72	1.79	1.87	1.92	2.03	2.31
6	D _b	7.07	7.26	7.50	7.77	7.88	7.99	8.09	8.16	8.23	8.30	8.36	8.48	8.76
	H	.74	.89	1.09	1.31	1.41	1.50	1.59	1.65	1.71	1.77	1.82	1.93	2.19
7	D _b	8.12	8.32	8.56	8.75	8.85	8.96	9.07	9.13	9.20	9.27	9.32	9.45	9.72
	H	.78	.93	1.11	1.28	1.35	1.44	1.53	1.59	1.63	1.69	1.74	1.87	2.07
8	D _b	9.18	9.37	9.62	9.72	9.83	9.93	10.04	10.10	10.16	10.23	10.28	10.42	10.69
	H	.81	.96	1.15	1.23	1.31	1.39	1.43	1.53	1.58	1.63	1.68	1.81	2.03
9	D _b	10.22	10.42	10.61	10.70	10.80	10.91	11.02	11.08	11.13	11.20	11.26	11.40	11.65
	H	.84	.99	1.12	1.20	1.28	1.35	1.45	1.49	1.54	1.58	1.64	1.75	1.97
10	D _b	11.25	11.47	11.60	11.68	11.78	11.89	11.99	12.05	12.11	12.18	12.24	12.38	12.62
	H	.86	1.02	1.11	1.17	1.25	1.33	1.41	1.44	1.50	1.54	1.60	1.72	1.91

TABLE V-B-23
SPINNING RESULTS
COLUMBIUM (10 Mo-10 Ti)
TEMPERATURE 750°F

Gage (t)		.016	.020	.025	.032	.040	.050	.063	.071	.080	.090	.100	.125	.187
Die Diameter (D _d)		Flange Height (H): Blank Diameter (D _b)												
1	D _b	1.33	1.33											
	H	.26	.26											
2	D _b	2.51	2.60	2.65	2.65	2.65	2.65	2.65	2.65	2.65	2.65	2.65		
	H	.37	.44	.48	.48	.48	.48	.48	.48	.48	.48	.48		
3	D _b	3.57	3.66	3.69	3.72	3.77	3.81	3.84	3.88	3.90	3.92	3.95	3.97	3.97
	H	.41	.47	.50	.52	.56	.59	.61	.65	.66	.68	.70	.72	.72
4	D _b	4.61	4.64	4.68	4.70	4.75	4.79	4.82	4.85	4.88	4.90	4.93	4.97	5.06
	H	.42	.44	.48	.49	.53	.56	.58	.61	.64	.65	.66	.70	.78
5	D _b	5.59	5.62	5.66	5.69	5.73	5.77	5.81	5.84	5.86	5.88	5.90	5.95	6.03
	H	.41	.43	.45	.47	.50	.54	.57	.59	.60	.62	.63	.68	.73
6	D _b	6.58	6.61	6.65	6.68	6.72	6.75	6.79	6.82	6.84	6.86	6.88	6.93	7.02
	H	.40	.42	.44	.46	.49	.52	.54	.57	.58	.59	.62	.64	.71
7	D _b				7.67	7.71	7.74	7.78	7.81	7.82	7.84	7.87	7.91	8.00
	H				.45	.48	.50	.53	.55	.56	.57	.60	.62	.69
8	D _b				8.65	8.70	8.73	8.77	8.80	8.81	8.83	8.86	8.90	8.99
	H				.44	.47	.49	.52	.54	.55	.57	.58	.62	.68
9	D _b							9.76	9.78	9.80	9.82	9.85	9.89	9.98
	H							.51	.52	.53	.54	.55	.60	.66
10	D _b							10.75	10.77	10.79	10.81	10.83	10.88	10.97
	H							.50	.52	.53	.54	.55	.60	.65

SECTION VI
SHALLOW RECESSING
A. BEADING ON THE RUBBER PRESS
B. BEADING ON THE DROP HAMMER

BEADING ON THE RUBBER PRESS

Description of Process

The rubber bead process is used to form beads in sheet metal structures for stiffening purposes. This process is usually restricted to the forming of low strength materials such as aluminum and magnesium in their soft condition. This restriction is imposed on the process because of the requirement of high rubber pressure to produce parts of good bead definition.

An HPM Diaform Press with an operating pressure of 3000 psi was used in this evaluation. This pressure will produce good part definition (free form radius) for the practical gages of 2024-0 aluminum and for the lighter gages of the higher strength materials.

The process of forming beaded panels on a rubber press is relatively simple. Tooling consists of a form block containing male beads positioned at the desired location on the form block. The sheet metal blank to be beaded is prepared by profile trimming, blanking dies, or by sawing. The prepared sheet metal blank is positioned on the form block then formed by rubber pressure acting on the blank.

The criteria for failure in rubber bead forming are splitting and insufficient pressure. Splitting is due to the physical properties of the material, the applied rubber pressure, and the geometric variables. Insufficient pressure is due mainly to inadequate rubber pressure but is dependent on the geometric variables and the material properties. For the purpose of this evaluation parts are considered

unacceptable due to insufficient pressure if there is less than 1/2" flat area between beads.

Other factors that may be considered limiting factors in rubber bead forming are longitudinal buckling and free form radius. Longitudinal buckling generally occurs in the heavy gage materials where the bead is of insufficient length. The free form radius may be considered a limiting factor due to the fact that a large free form radius reduces the stiffening characteristics of a bead.

Definition of Part Shape and Geometric Variables

The geometric variables considered in the rubber bead formability limits are material thickness (t), bead radius (R), and distance between bead centers (L). Other variables include free form radius (R_f), and bead length (L_2). The free form radius and bead length were not considered in the construction of the formability curves; however, they may impose restrictions on design limits as previously described.

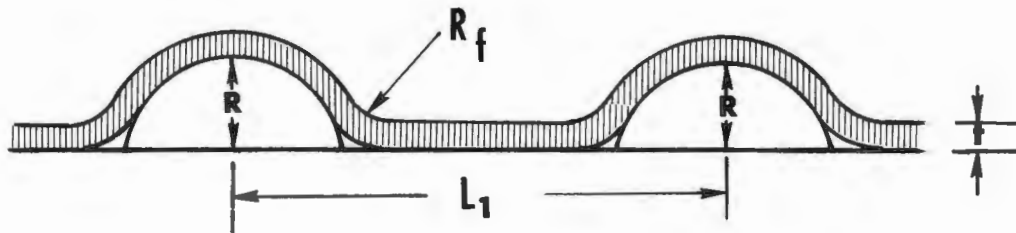

FIGURE VI A-1 CROSS-SECTION AND SIDE VIEW OF BEAD

Predictability Equations

The predictability equations for rubber bead forming are as follows:

The equation for the pressure index line:

$$\frac{R}{L} = 0.065 \left[\frac{R}{t} \right]^{0.37} \quad \text{Equation I}$$

The equation for the pressure line:

$$\frac{R}{L} = 0.065 \left[\frac{\frac{1}{S_{IV}} \times 10^4}{0.065} \right]^{0.216} \left[\frac{R}{t} \right]^{0.29} \quad \text{Equation II}$$

The equation for the splitting index line:

$$\frac{R}{L} = 6.84 \times 10^{-4} \left(\frac{R}{t} \right)^{1.5} \quad \text{Equation III}$$

The equation for the lower portion of the splitting line:

$$\frac{R}{L} = 6.0 \times 10^{-21} \left[\epsilon_{2.0} S_u \right]^{9.3} \left[\frac{R}{t} \right]^{-12.4}$$

Equation IV

To construct a formability curve using the predictability equations the following procedure is followed:

Step 1: Using Equation II, construct the pressure limit line. Arbitrarily select practical values for R/t and solve for R/L. The pressure limit line is a straight line; therefore, only two points, P₁ and P₂, are necessary. Connect these points as shown in the following sketch:

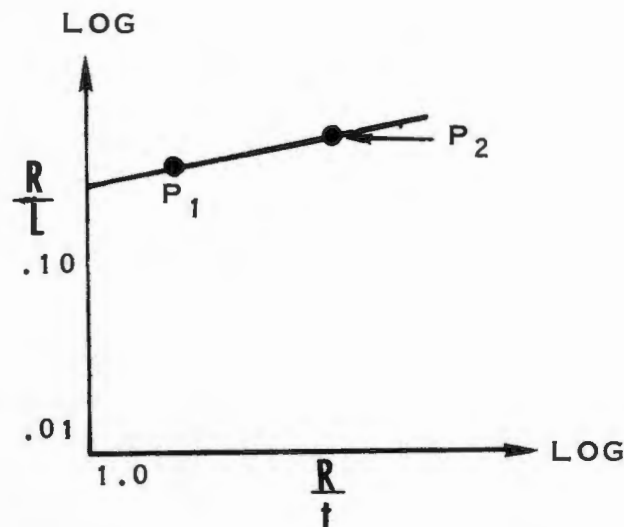

FIGURE VI A-2 GRAPH CONSTRUCTION

Step 2: Using Equation IV construct the lower portion of the splitting line. Solve for R/L by inserting the numerical values for $\epsilon_{2.0}$ and S_u and select practical values for R/t . Solve two points for R/L and draw a line through these points, P_1 and P_2 , extending it from the R/t axis to the $R/L = .10$ line as shown in the following sketch:

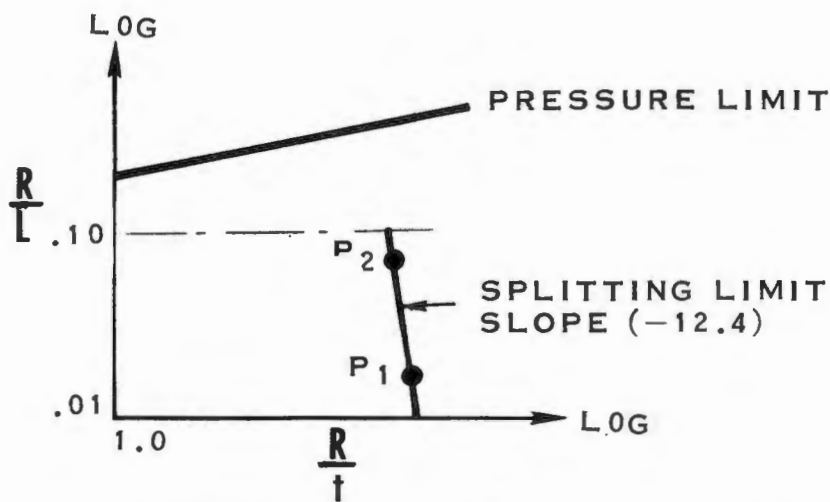

FIGURE VI A-3 GRAPH CONSTRUCTION

The remaining or upper portion of the splitting limit line has no developed predictability equation. The line is a continuous curve extending from the $h/R = 1.0$ line to the pressure limit line. This line may be fayed in by referring to the composite graph for rubber bead forming that is presented in this report. For demonstration purposes the following sketch is drawn with known curve locations for material A and C. After finding the pressure limit line and lower

splitting line for material B, lay in the upper splitting line symmetrically as shown in the following sketch:

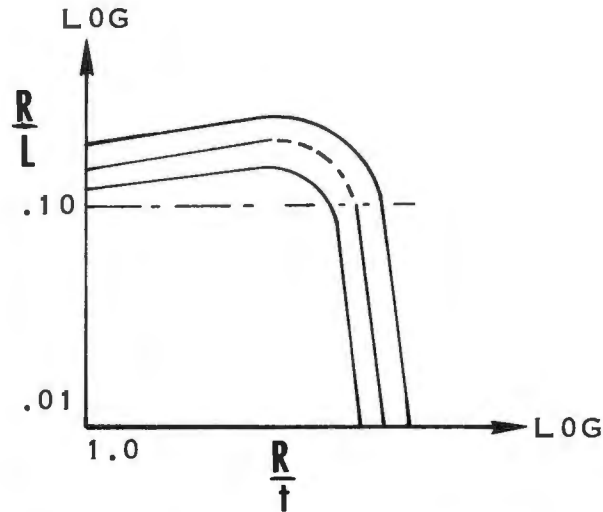

FIGURE VI A-4 GRAPH CONSTRUCTION

The completion of the foregoing step will give a complete formability curve for rubber bead forming. A curve showing good and split parts is shown in the following sketch;

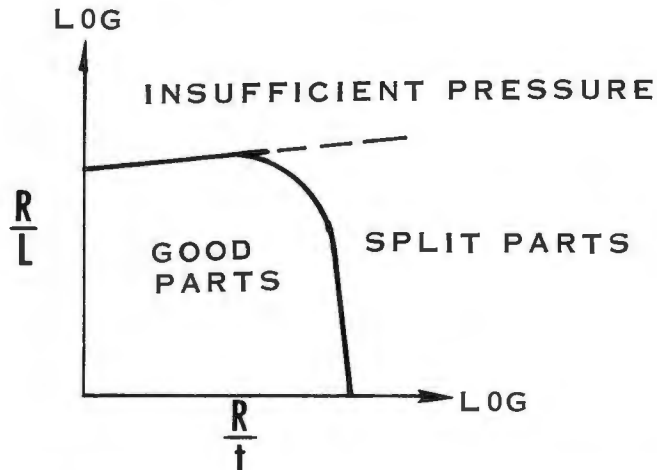

FIGURE VI A-5 TYPICAL FORMABILITY CURVE

Composite Graphs

The formability curves representing the forming limits of all applicable materials evaluated under this contract will appear in Graph VI A-1.

The individual graphs and design data in tabular form are based on the minimum material properties. Due to the fact that there is a considerable range in physical properties of any material, the formability limits will vary with this range. An example of the possible forming range is shown in the following sketch:

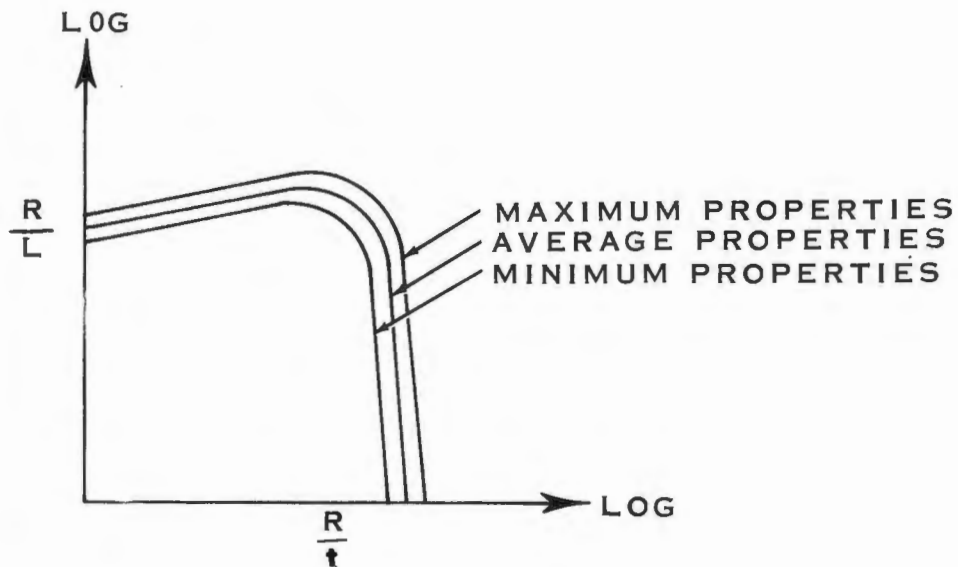
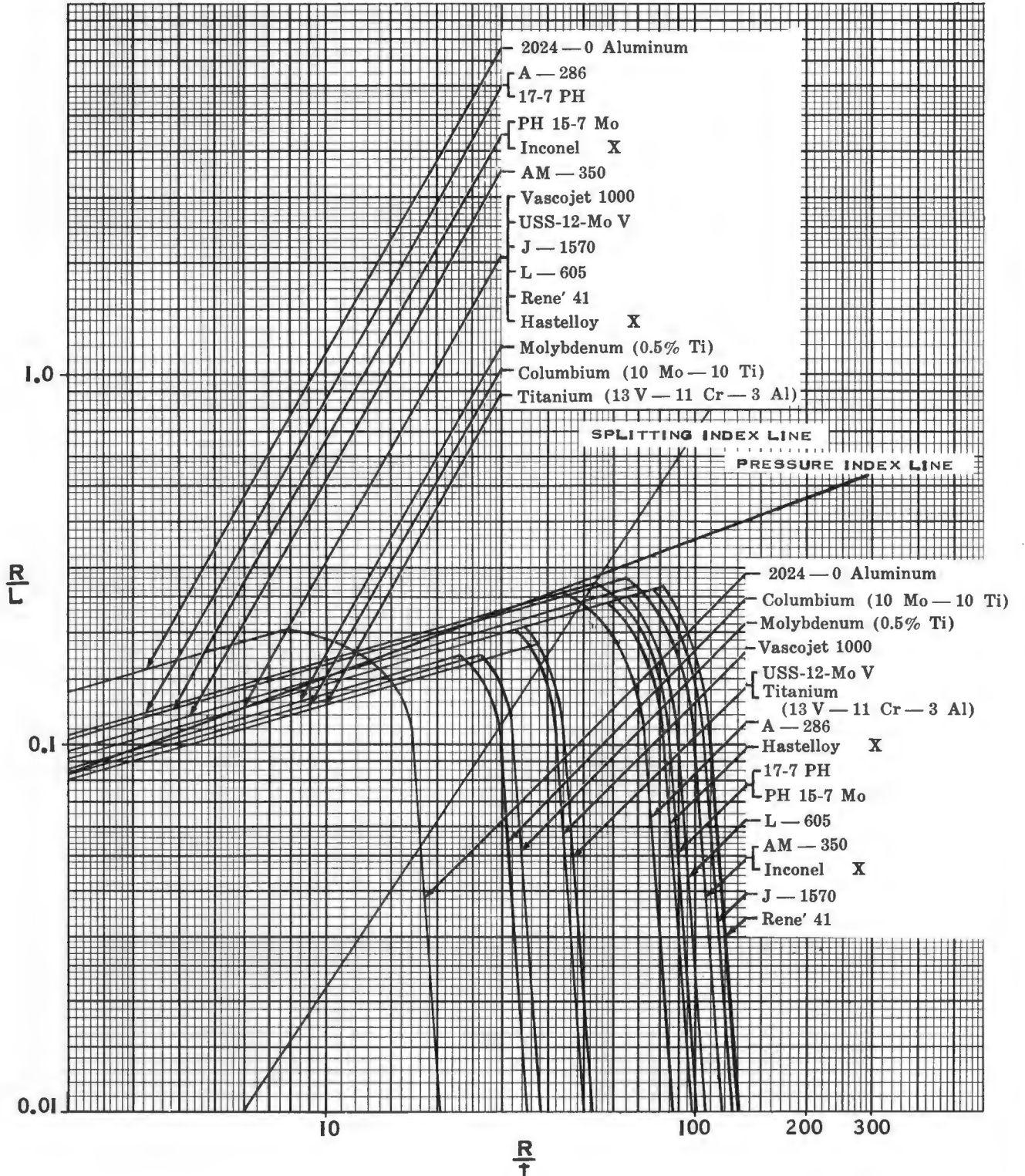

FIGURE VI A-6 RANGE IN FORMABILITY LIMITS

GRAPH VI A-I

COMPOSITE GRAPH FOR RUBBER BEAD PANELS



GRAPH VI A-2

ALTERNATE METHOD OF PLOTTING
RUBBER BEAD FORMING LIMITS

2024-0 ALUMINUM

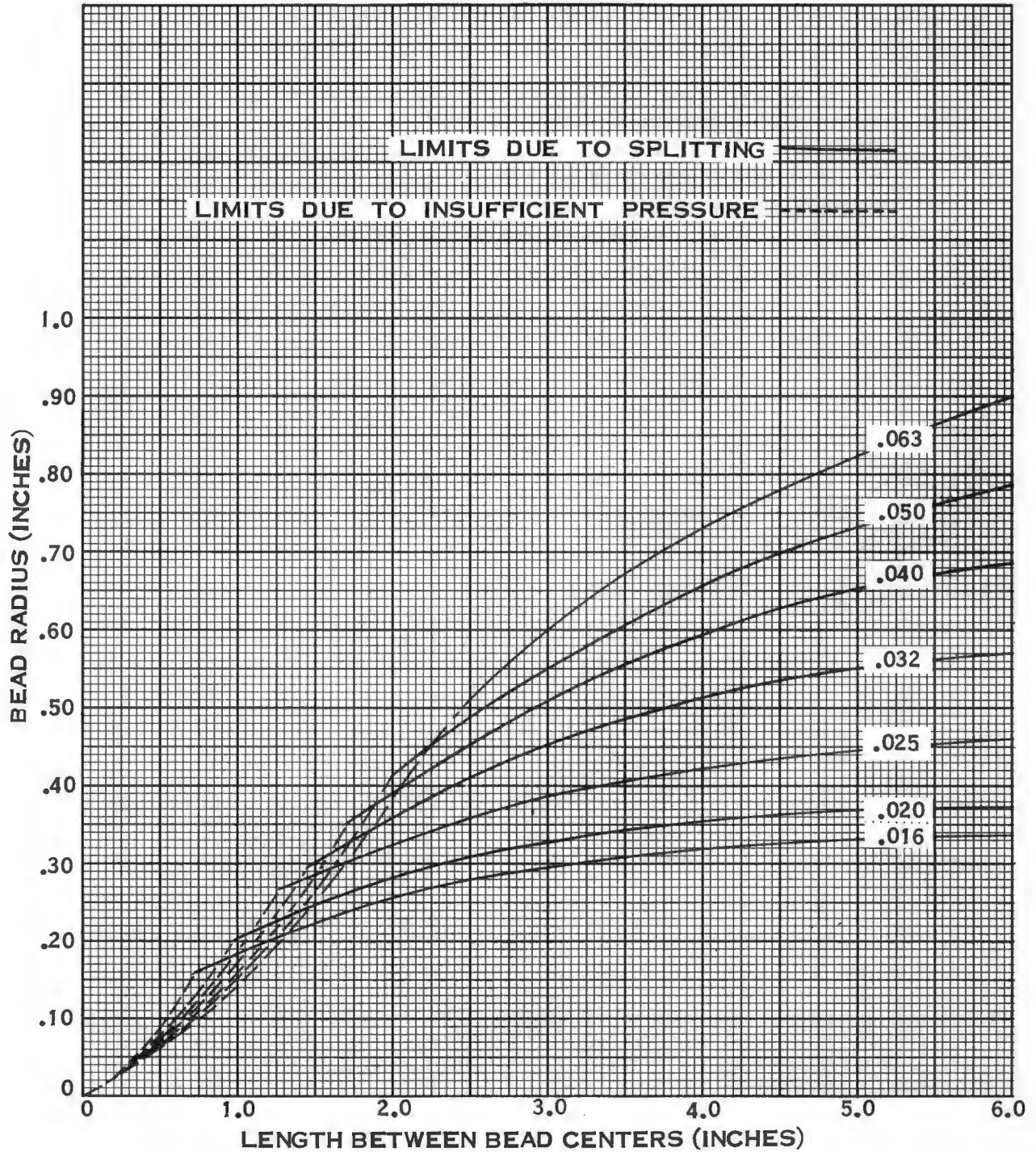

Design Tables

Design tables for all materials evaluated except HM21XA-T8 Titanium (6Al - 4V), Tungsten, and Beryllium are shown in Tables VI A-1 through VI A-15. HM21XA-T8 and Titanium (6Al-4V) are excluded due to the fact that their minimum bend properties coupled with tensile stresses are such that splitting occurs across the top of the bead on all practical panels. Tungsten and Beryllium are excluded due to their very brittle nature and low formability limits at the maximum operating temperature of rubber forming.

The design limits for .125 and .187 gage materials are excluded due to the large free form radius that can be expected of these gages.

The vacant spaces in the lower left hand corner of the design tables are vacant because of the impracticality of forming in this range.

The free form radius (R_f) for each gage of each material is included in the design tables. This variable is not considered in the formability limits; however, it should be considered when selecting a forming process. In many cases the following design tables will include formable parts where (R_f) is much larger than the actual bead radius.

Design limits listed in the design tables that appear above and to the right of the heavy line are limits due to insufficient pressure, whereas those that appear below and to the left of the line are limits due to splitting.

The design limits for rubber bead forming are constructed such that the minimum possible distance between bead centers can be determined for any practical bead radius and material thickness.

The design limits listed in the following tables are based on an operating rubber pressure of 3000 psi. Due to the nature of the process an increase in pressure will result in lower splitting limits but a better bead definition can be expected.

TABLE VI A-1
 RUBBER HEAD FORMING LIMITS
 2024-O ALUMINUM

Gage (t)	.016	.020	.025	.032	.040	.050	.063	.071	.080	.090	.100	.125	.187
Radius (R_f)	.149	.187	.233	.299	.373	.470	.587	.663	.747	.830	.930		
Radius (R)	L (Distance Between Centers)												
0.25	1.9	1.4	1.3	1.2	1.3	1.4	1.4	1.5	1.5	1.6	1.7		
0.30	4.6	2.1	1.7	1.5	1.5	1.6	1.7	1.7	1.8	1.8	1.9		
0.35		4.4	2.3	1.9	1.7	1.7	1.9	2.0	2.0	2.1	2.1		
0.40			3.2	2.3	2.1	2.0	2.0	2.1	2.2	2.3	2.3		
0.45				2.9	2.4	2.2	2.2	2.3	2.4	2.5	2.6		
0.50				3.8	2.9	2.6	2.5	2.5	2.6	2.7	2.8		
0.60					4.0	3.4	3.0	3.0	3.0	3.0	3.1		
0.70						4.5	3.7	3.6	3.5	3.4	3.5		
0.80						6.4	4.7	4.3	4.1	4.0	3.9		
0.90							6.0	5.3	4.9	4.6	4.5		
1.00							7.7	6.5	5.7	5.4	5.2		

TABLE VI A-2
 RUBBER BEAD FORMING LIMITS
 17-7 PH (CONDITION A)

Gage (t)	.016	.020	.025	.032	.040	.050	.063	.071	.080	.090	.100	.125	.187
Radius (R _F)	.720	.900	1.12	1.44	1.80	2.25	2.83	3.19	3.6	4.05	4.5		
Radius (R)	L (Distance Between Centers)												
0.25	1.3	1.4	1.5	1.6	1.7	1.9	2.0	2.1	2.2	2.2	2.3		
0.30	1.5	1.6	1.7	1.8	2.0	2.1	2.3	2.4	2.5	2.5	2.6		
0.35	1.7	1.8	1.9	2.1	2.2	2.3	2.5	2.6	2.7	2.8	2.9		
0.40	1.8	2.0	2.1	2.3	2.4	2.6	2.8	2.9	3.0	3.1	3.2		
0.45	2.0	2.1	2.2	2.4	2.6	2.8	3.0	3.1	3.2	3.4	3.5		
0.50	2.1	2.3	2.4	2.6	2.8	3.0	3.3	3.4	3.5	3.6	3.7		
0.60	2.4	2.6	2.8	3.0	3.2	3.4	3.7	3.8	4.0	4.1	4.2		
0.70	2.7	2.9	3.1	3.3	3.5	3.7	4.0	4.2	4.4	4.6	4.7		
0.80	3.0	3.2	3.4	3.6	3.9	4.2	4.5	4.7	4.9	5.0	5.2		
0.90	3.4	3.4	3.7	3.9	4.2	4.5	4.8	5.0	5.2	5.3	5.6		
1.00	4.1	3.7	4.0	4.3	4.6	4.9	5.2	5.4	5.6	5.8	5.9		

TABLE VI A-3
 RUBBER BEAD FORMING LIMITS
 PH 15-7 Mo (CONDITION A)

Gage (t)	.016	.020	.025	.032	.040	.050	.063	.071	.080	.090	.100	.125	.187
Radius (R_F)	.71	.89	1.11	1.42	1.77	2.22	2.80	3.15	3.55	4.00	4.44		
Radius (R)	L (Distance Between Centers)												
0.25	1.3	1.4	1.5	1.6	1.7	1.9	2.0	2.1	2.2	2.2	2.3		
0.30	1.5	1.6	1.7	1.8	2.0	2.1	2.3	2.4	2.5	2.5	2.6		
0.35	1.7	1.8	1.9	2.1	2.2	2.3	2.5	2.6	2.7	2.8	2.9		
0.40	1.9	2.0	2.1	2.3	2.4	2.6	2.8	2.9	3.0	3.1	3.2		
0.45	2.0	2.2	2.3	2.5	2.6	2.8	3.0	3.1	3.2	3.4	3.5		
0.50	2.2	2.4	2.5	2.6	2.9	3.1	3.3	3.4	3.5	3.6	3.7		
0.60	2.5	2.7	2.9	3.1	3.3	3.5	3.7	3.8	4.0	4.1	4.2		
0.70	2.8	3.0	3.2	3.4	3.6	3.8	4.0	4.2	4.4	4.6	4.7		
0.80	3.1	3.3	3.5	3.8	4.0	4.2	4.5	4.7	4.9	5.0	5.2		
0.90	3.4	3.6	3.8	4.0	4.3	4.6	4.9	5.1	5.3	5.5	5.6		
1.00	4.1	3.9	4.1	4.4	4.7	5.0	5.3	5.6	5.8	5.9	6.1		

TABLE VI A-4
 RUBBER BEAD FORMING LIMITS
 AM-350 (ANNEALED)

Gage (t)	.016	.020	.025	.032	.040	.050	.063	.071	.080	.090	.100	.125	.187
Radius (R_f)	8.53	1.07	1.34	1.71	2.13	2.66	3.36	3.78	4.26	4.80	5.33		
Radius (R)	L (Distance Between Centers)												
0.25	1.5	1.6	1.7	1.8	1.9	2.1	2.2	2.3	2.4	2.5	2.5		
0.30	1.7	1.8	1.9	2.0	2.2	2.3	2.5	2.6	2.7	2.8	2.9		
0.35	1.9	2.0	2.1	2.3	2.4	2.6	2.7	2.9	3.0	3.1	3.2		
0.40	2.0	2.2	2.3	2.5	2.7	2.9	3.0	3.1	3.3	3.4	3.5		
0.45	2.2	2.4	2.5	2.7	2.9	3.1	3.3	3.4	3.5	3.7	3.8		
0.50	2.4	2.5	2.7	2.9	3.1	3.3	3.5	3.7	3.8	3.9	4.1		
0.60	2.6	2.9	3.1	3.3	3.5	3.8	4.0	4.2	4.3	4.5	4.7		
0.70	2.9	3.1	3.5	3.7	3.9	4.2	4.5	4.7	4.9	5.1	5.2		
0.80	3.2	3.5	3.8	4.1	4.4	4.7	5.0	5.2	5.3	5.5	5.7		
0.90	3.5	3.7	4.0	4.5	4.7	5.0	5.3	5.6	5.8	6.0	6.2		
1.00	3.7	4.0	4.4	4.8	5.1	5.5	5.8	6.1	6.3	6.5	6.7		

TABLE VI A-5
 RUBBER BEAD FORMING LIMITS
 A-286 (SOLUTION TREATED)

Gage (t)	.016	.020	.025	.032	.040	.050	.063	.071	.080	.090	.100	.125	.187
Radius (R_f)	.480	.600	.750	.990	1.20	1.50	1.89	2.13	2.4	2.7	3.0		
Radius (R)	L (Distance Between Centers)												
0.25	1.3	1.4	1.5	1.6	1.7	1.9	2.0	2.1	2.2	2.2	2.3		
0.30	1.5	1.6	1.7	1.8	2.0	2.1	2.3	2.4	2.5	2.5	2.6		
0.35	1.7	1.8	1.9	2.1	2.2	2.3	2.5	2.6	2.7	2.8	2.9		
0.40	1.9	2.0	2.1	2.3	2.4	2.6	2.8	2.9	3.0	3.1	3.2		
0.45	2.0	2.2	2.3	2.5	2.6	2.8	3.0	3.1	3.2	3.4	3.5		
0.50	2.2	2.4	2.5	2.6	2.9	3.1	3.3	3.4	3.5	3.6	3.7		
0.60	2.5	2.7	2.9	3.1	3.3	3.5	3.7	3.8	4.0	4.1	4.2		
0.70	2.8	3.0	3.2	3.4	3.6	3.8	4.0	4.2	4.4	4.6	4.7		
0.80	3.4	3.3	3.5	3.8	4.0	4.2	4.5	4.7	4.9	5.0	5.2		
0.90	4.3	3.6	3.8	4.0	4.3	4.6	4.9	5.1	5.3	5.5	5.6		
1.00	5.4	4.3	4.1	4.4	4.7	5.0	5.3	5.6	5.8	5.9	6.1		

TABLE VI A-6
RUBBER BEAD FORMING LIMITS
USS-12-MoV (ANNEALED)

Gage (t)	.016	.020	.025	.032	.040	.050	.063	.071	.080	.090	.100	.125	.187
Radius (R _f)	.532	.660	.832	1.06	1.33	1.66	2.10	2.36	2.66	2.99	3.33		
Radius (R)	L (Distance Between Centers)												
0.25	1.5	1.6	1.7	1.8	1.9	2.1	2.2	2.3	2.4	2.5	2.5		
0.30	1.7	1.8	1.9	2.0	2.2	2.3	2.5	2.6	2.7	2.8	2.9		
0.35	1.9	2.0	2.1	2.3	2.4	2.6	2.7	2.9	3.0	3.1	3.2		
0.40	2.0	2.2	2.3	2.5	2.7	2.9	3.0	3.1	3.3	3.4	3.5		
0.45	2.2	2.4	2.5	2.7	2.9	3.1	3.3	3.4	3.5	3.7	3.8		
0.50	2.4	2.5	2.7	2.9	3.1	3.3	3.5	3.7	3.8	3.9	4.1		
0.60	3.2	2.9	3.1	3.3	3.5	3.8	4.0	4.2	4.3	4.5	4.7		
0.70	5.6	3.5	3.5	3.7	3.9	4.2	4.5	4.7	4.9	5.1	5.2		
0.80		4.5	3.8	4.1	4.4	4.7	5.0	5.2	5.3	5.5	5.7		
0.90		9.8	4.5	4.5	4.7	5.0	5.3	5.6	5.8	6.0	6.2		
1.00			5.6	4.8	5.1	5.5	5.8	6.1	6.3	6.5	6.7		

TABLE VI A-7
 RUBBER BEAD FORMING LIMITS
 TITANIUM (13V-11Cr-3Al) (SOLUTION TREATED)

Gage (t)	.016	.020	.025	.032	.040	.050	.063	.071	.080	.090	.100	.125	.187
Radius (R _f)	.710	.890	1.11	1.42	1.77	2.22	2.80	3.15	3.55	4.00	4.44		
Radius (R)	L (Distance Between Centers)												
0.25	1.7	1.8	1.9	2.0	2.2	2.4	2.5	2.6	2.7	2.8	2.9		
0.30	1.9	2.0	2.2	2.3	2.5	2.7	2.9	3.0	3.1	3.2	3.3		
0.35	2.1	2.3	2.4	2.6	2.8	3.0	3.2	3.3	3.4	3.5	3.6		
0.40	2.3	2.5	2.7	2.9	3.1	3.3	3.5	3.6	3.8	3.9	4.0		
0.45	2.5	2.7	2.9	3.1	3.3	3.5	3.7	3.9	4.1	4.3	4.4		
0.50	2.7	2.9	3.1	3.3	3.5	3.8	4.0	4.2	4.4	4.5	4.7		
0.60	3.2	3.4	3.5	3.8	4.0	4.3	4.6	4.8	5.0	5.2	5.4		
0.70	5.8	3.7	4.0	4.3	4.6	4.9	5.2	5.4	5.6	5.7	5.9		
0.80		4.7	4.4	4.7	5.0	5.3	5.7	5.9	6.1	6.3	6.5		
0.90			4.7	5.0	5.4	5.8	6.1	6.4	6.7	6.9	7.1		
1.00			5.9	5.5	5.9	6.3	6.7	6.9	7.1	7.4	7.7		

TABLE VI A-8
 RUBBER BEAD FORMING LIMITS
 VASCOJET 1000 (H-11)(ANNEALED)

Gage (t)	.016	.020	.025	.032	.040	.050	.063	.071	.080	.090	.100	.125	.187
Radius (R _F)	.532	.660	.832	1.06	1.33	1.66	2.10	2.36	2.66	2.99	3.33		
Radius (R)	L (Distance Between Centers)												
0.25	1.5	1.6	1.7	1.8	1.9	2.0	2.2	2.3	2.4	2.5	2.5		
0.30	1.7	1.8	1.9	2.1	2.2	2.3	2.5	2.6	2.7	2.8	2.9		
0.35	1.9	2.0	2.1	2.3	2.4	2.6	2.8	2.9	3.0	3.1	3.2		
0.40	2.0	2.2	2.3	2.5	2.7	2.9	3.1	3.2	3.3	3.4	3.5		
0.45	2.2	2.4	2.5	2.7	2.9	3.1	3.3	3.4	3.5	3.7	3.8		
0.50	2.4	2.6	2.7	2.9	3.1	3.3	3.6	3.8	3.9	4.0	4.1		
0.60	3.5	2.9	3.1	3.3	3.6	3.8	4.1	4.3	4.4	4.5	4.6		
0.70		3.7	3.5	3.7	4.0	4.3	4.5	4.7	4.9	5.1	5.2		
0.80		5.3	3.9	4.1	4.4	4.7	5.0	5.2	5.3	5.5	5.7		
0.90			5.0	4.4	4.7	5.1	5.4	5.6	5.8	6.0	6.2		
1.00			6.7	4.8	5.1	5.5	5.9	6.1	6.3	6.5	6.7		

TABLE VI A-9
 RUBBER BEAD FORMING LIMITS
 RENE⁴¹ (SOLUTION TREATED)

Gage (t)	.016	.020	.025	.032	.040	.050	.063	.071	.080	.090	.100	.125	.187
Radius (R_f)	.673	.966	1.21	1.55	1.93	2.41	3.04	3.43	3.88	4.35	4.83		
Radius (R)	L (Distance Between Centers)												
0.25	1.5	1.6	1.7	1.8	1.9	2.1	2.2	2.3	2.4	2.5	2.5		
0.30	1.7	1.8	1.9	2.0	2.2	2.3	2.5	2.6	2.7	2.8	2.9		
0.35	1.9	2.0	2.1	2.3	2.4	2.6	2.7	2.9	3.0	3.1	3.2		
0.40	2.0	2.2	2.3	2.5	2.7	2.9	3.0	3.1	3.3	3.4	3.5		
0.45	2.2	2.4	2.5	2.7	2.9	3.1	3.3	3.4	3.5	3.7	3.8		
0.50	2.4	2.5	2.7	2.9	3.1	3.3	3.5	3.7	3.8	3.9	4.1		
0.60	2.7	2.9	3.1	3.3	3.5	3.8	4.0	4.2	4.3	4.5	4.7		
0.70	3.1	3.3	3.5	3.7	3.9	4.2	4.5	4.7	4.9	5.1	5.2		
0.80	3.4	3.6	3.8	4.1	4.4	4.7	5.0	5.2	5.3	5.5	5.7		
0.90	3.6	3.9	4.3	4.5	4.7	5.0	5.3	5.6	5.8	6.0	6.2		
1.00	4.0	4.2	4.5	4.8	5.1	5.5	5.8	6.1	6.3	6.5	6.7		

TABLE VI A-10
 RUBBER BEAD FORMING LIMITS
 INCONEL X (C.R. ANNEALED)

Gage (t)	.016	.020	.025	.032	.040	.050	.063	.071	.080	.090	.100	.125	.187
Radius (R_f)	.603	.754	.942	1.21	1.51	1.88	2.51	2.67	3.01	3.39	3.77		
Radius (R)	L (Distance Between Centers)												
0.25	1.3	1.4	1.5	1.6	1.7	1.9	2.0	2.1	2.2	2.2	2.3		
0.30	1.5	1.6	1.7	1.8	2.0	2.1	2.3	2.4	2.5	2.5	2.6		
0.35	1.7	1.8	1.9	2.1	2.2	2.3	2.5	2.6	2.7	2.8	2.9		
0.40	1.9	2.0	2.1	2.3	2.4	2.6	2.8	2.9	3.0	3.1	3.2		
0.45	2.0	2.2	2.3	2.5	2.6	2.8	3.0	3.1	3.2	3.4	3.5		
0.50	2.2	2.4	2.5	2.6	2.9	3.1	3.3	3.4	3.5	3.6	3.7		
0.60	2.5	2.7	2.9	3.1	3.3	3.5	3.7	3.8	4.0	4.1	4.2		
0.70	2.8	3.0	3.2	3.4	3.6	3.8	4.0	4.2	4.4	4.6	4.7		
0.80	3.1	3.3	3.5	3.8	4.0	4.2	4.5	4.7	4.9	5.0	5.2		
0.90	3.4	3.6	3.8	4.0	4.3	4.6	4.9	5.1	5.3	5.5	5.6		
1.00	3.7	3.9	4.1	4.4	4.7	5.0	5.3	5.6	5.8	5.9	6.1		

TABLE VI A-11
 RUBBER BEAD FORMING LIMITS
 HASTELLOY X (SOLUTION TREATED)

Gage (t)	.016	.020	.025	.032	.040	.050	.063	.071	.080	.090	.100	.125	.187
Radius (R _F)	.596	.746	.922	1.20	1.50	1.86	2.35	2.64	2.98	3.36	3.73		
Radius (R)	L (Distance Between Centers)												
0.25	1.4	1.5	1.6	1.7	1.8	1.9	2.1	2.2	2.2	2.3	2.4		
0.30	1.6	1.7	1.8	2.0	2.1	2.2	2.4	2.5	2.5	2.6	2.7		
0.35	1.8	1.9	2.0	2.2	2.3	2.5	2.6	2.7	2.8	2.9	3.0		
0.40	2.0	2.1	2.2	2.4	2.6	2.7	2.9	3.0	3.1	3.2	3.3		
0.45	2.1	2.3	2.5	2.7	2.8	3.0	3.2	3.3	3.4	3.5	3.6		
0.50	2.3	2.5	2.6	2.8	3.0	3.2	3.4	3.5	3.7	3.8	3.9		
0.60	2.6	2.8	3.0	3.2	3.4	3.7	3.9	4.0	4.2	4.3	4.4		
0.70	2.9	3.1	3.3	3.6	3.8	4.1	4.3	4.5	4.7	4.8	5.0		
0.80	3.2	3.5	3.7	4.0	4.2	4.4	4.7	4.9	5.1	5.3	5.4		
0.90	3.6	3.7	4.0	4.3	4.6	4.9	5.2	5.3	5.5	5.8	5.9		
1.00	4.5	4.0	4.3	4.6	4.9	5.3	5.6	5.8	6.0	6.2	6.4		

TABLE VI A-12
 RUBBER BEAD FORMING LIMITS
 L-605 (SOLUTION TREATED)

Gage (t)	.016	.020	.025	.032	.040	.050	.063	.071	.080	.090	.100	.125	.187
Radius (R_f)	.69	.87	1.08	1.38	1.73	2.16	2.72	3.07	3.46	3.90	4.33		
Radius (R)	L (Distance Between Centers)												
0.25	1.5	1.6	1.7	1.8	1.9	2.0	2.2	2.3	2.4	2.5	2.5		
0.30	1.7	1.8	1.9	2.1	2.2	2.3	2.5	2.6	2.7	2.8	2.9		
0.35	1.9	2.0	2.1	2.3	2.4	2.6	2.8	2.9	3.0	3.1	3.2		
0.40	2.0	2.2	2.3	2.5	2.7	2.9	3.1	3.2	3.3	3.4	3.5		
0.45	2.2	2.4	2.5	2.7	2.9	3.1	3.3	3.4	3.5	3.7	3.8		
0.50	2.4	2.6	2.7	2.9	3.1	3.3	3.6	3.8	3.9	4.0	4.1		
0.60	2.7	2.9	3.1	3.3	3.6	3.8	4.1	4.3	4.4	4.5	4.6		
0.70	3.0	3.2	3.5	3.7	4.0	4.3	4.5	4.7	4.9	5.1	5.2		
0.80	3.2	3.5	3.7	4.1	4.4	4.7	5.0	5.2	5.3	5.5	5.7		
0.90	3.5	3.8	4.1	4.4	4.7	5.1	5.4	5.6	5.8	6.0	6.2		
1.00	3.9	4.0	4.4	4.8	5.1	5.5	5.9	6.1	6.3	6.5	6.7		

TABLE VI A-13
 RUBBER BEAD FORMING LIMITS
 J-1570 (SOLUTION TREATED)

Gage (t)	.016	.020	.025	.032	.040	.050	.063	.071	.080	.090	.100	.125	.187
Radius (R _f)	.74	.92	1.15	1.48	1.84	2.30	2.90	3.27	3.68	4.14	4.16		
Radius (R)	L (Distance Between Centers)												
0.25	1.7	1.8	1.9	2.0	2.1	2.2	2.3	2.4	2.5	2.6	2.6		
0.30	1.9	2.0	2.1	2.2	2.4	2.5	2.7	2.8	2.9	3.0	3.1		
0.35	2.2	2.3	2.4	2.6	2.7	2.9	3.0	3.1	3.2	3.3	3.4		
0.40	2.4	2.5	2.6	2.8	3.0	3.2	3.4	3.5	3.6	3.7	3.8		
0.45	2.6	2.8	2.9	3.1	3.2	3.4	3.6	3.7	3.9	4.0	4.1		
0.50	2.8	3.0	3.1	3.3	3.5	3.7	3.9	4.1	4.2	4.3	4.5		
0.60	3.2	3.4	3.6	3.8	4.0	4.3	4.5	4.7	4.8	5.0	5.1		
0.70	3.6	3.8	4.1	4.3	4.6	4.8	5.1	5.2	5.4	5.6	5.7		
0.80	4.0	4.2	4.4	4.8	5.0	5.3	5.7	5.8	5.9	6.1	6.3		
0.90	4.3	4.6	4.9	5.2	5.5	5.8	6.1	6.3	6.5	6.7	6.8		
1.00	4.7	5.0	5.3	5.6	5.9	6.3	6.6	6.8	7.1	7.3	7.4		

TABLE VI A-14
 RUBBER BEAD FORMING LIMITS
 COLUMBIUM (10 Mo-10 Ti)

Gage (t)	.016	.020	.025	.032	.040	.050	.063	.071	.080	.090	.100	.125	.187
Radius (R_f)	.59	.73	.92	1.17	1.47	1.84	2.31	2.60	2.94	3.30	3.67		
Radius (R)	L (Distance Between Centers)												
0.25	1.6	1.7	1.8	2.0	2.1	2.3	2.4	2.5	2.6	2.7	2.8		
0.30	1.8	2.0	2.1	2.2	2.4	2.5	2.7	2.8	2.9	3.0	3.1		
0.35	2.0	2.2	2.3	2.5	2.7	2.8	3.0	3.2	3.3	3.4	3.5		
0.40	2.5	2.4	2.5	2.7	2.9	3.1	3.3	3.5	3.6	3.7	3.8		
0.45	3.6	2.6	2.8	3.0	3.2	3.4	3.6	3.7	3.9	4.1	4.2		
0.50		3.1	3.0	3.2	3.4	3.6	3.9	4.1	4.2	4.3	4.5		
0.60		6.7	3.5	3.7	3.9	4.2	4.4	4.6	4.8	5.0	5.1		
0.70			5.3	4.1	4.4	4.7	5.0	5.2	5.4	5.5	5.7		
0.80				4.9	4.8	5.1	5.4	5.6	5.9	6.1	6.3		
0.90				7.2	5.2	5.6	6.0	6.1	6.3	6.6	6.8		
1.00					6.2	6.0	6.4	6.7	6.9	7.1	7.3		

TABLE VI A-15
 RUBBER BEAD FORMING LIMITS
 MOLYBDENUM (5% Ti)
 (HOT ROLLED, STRESS RELIEVED, DE-SCALED SHEET)

Gage (t)	.016	.020	.025	.032	.040	.050	.063	.071	.080	.090	.100	.125	.187
Radius (R_f)	.70	.87	1.09	1.40	1.75	2.18	2.75	3.10	3.50	3.93	4.37		
Radius (R)	L (Distance Between Centers)												
0.25	1.7	1.8	1.9	2.0	2.2	2.3	2.5	2.5	2.6	2.7	2.8		
0.30	1.9	2.0	2.1	2.3	2.5	2.6	2.8	2.9	3.0	3.1	3.2		
0.35	2.1	2.2	2.4	2.6	2.7	2.9	3.1	3.2	3.4	3.5	3.6		
0.40	2.3	2.5	2.6	2.8	3.0	3.2	3.4	3.6	3.7	3.8	4.0		
0.45	2.8	2.7	2.8	3.0	3.2	3.5	3.7	3.9	4.0	4.2	4.3		
0.50	3.7	2.9	3.1	3.3	3.5	3.8	4.0	4.2	4.3	4.5	4.6		
0.60		4.3	3.5	3.7	4.0	4.3	4.5	4.7	4.9	5.1	5.3		
0.70			4.3	4.2	4.4	4.7	5.1	5.3	5.5	5.7	5.8		
0.80			8.0	4.6	4.9	5.2	5.6	5.8	6.0	6.2	6.4		
0.90				5.7	5.3	5.7	6.0	6.3	6.5	6.8	6.9		
1.00				7.4	5.7	6.2	6.6	6.7	7.0	7.3	7.5		

BEADING ON THE DROP HAMMER

Description of the Process

Drop hammer forming is the process or operation of forming metal into a desired shape by repeated blows of a drop hammer ram.

All drop hammer forming in this program was of the typical nature and was conducted on a piston driven Cecostamp drop hammer. This particular drop hammer has a die bed area of 46" x 36" and operates at 120 lbs./in.² of air pressure. An illustration of this hammer is shown below.

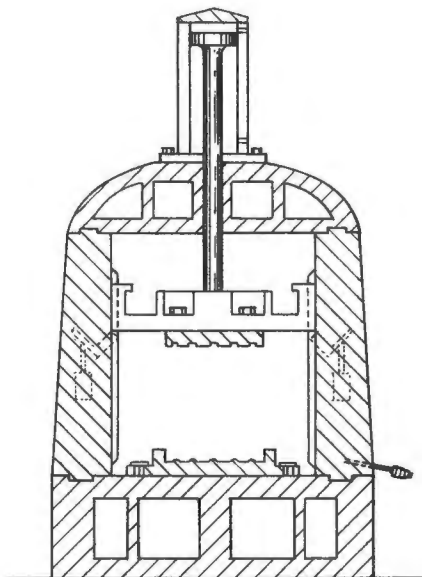

FIGURE VI B-1 DROP HAMMER SET-UP.

All testing and evaluation of the drop hammer process was performed on metal beaded panels. Special Kirksite beaded panel dies were fabricated into various bead configurations for this investigation. An illustration of a typical set of Kirksite beaded panel dies is shown in Figure VI B-2.

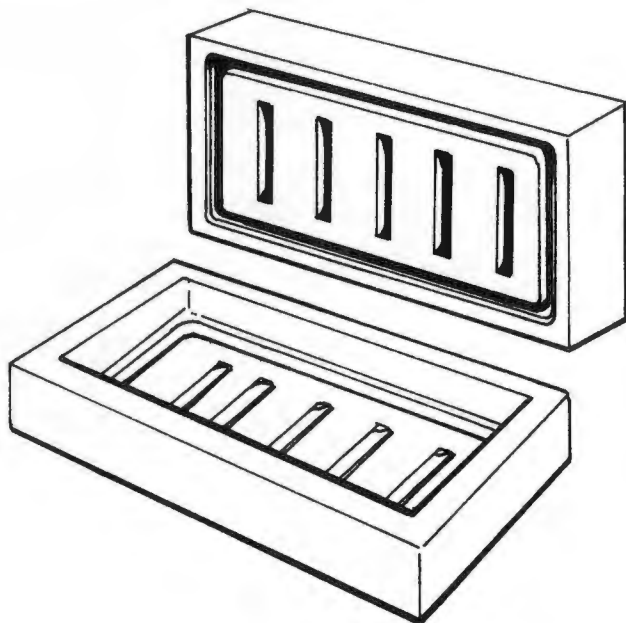

FIGURE VI B-2 TYPICAL KIRKSITE BEADED PANEL DIES.

To insure testing continuity of all forming operations, all operations were performed as close as possible to a standard operating procedure. This procedure is described as follows.

The forming process was accomplished in several stages. First, starting the process with thick heavy rubber mats laid over the metal part to be formed. (See Figure VI B-3). Then, reducing the thickness of the rubber mats at each stage until the final stage, which is accomplished with metal to metal contact of the die and part.

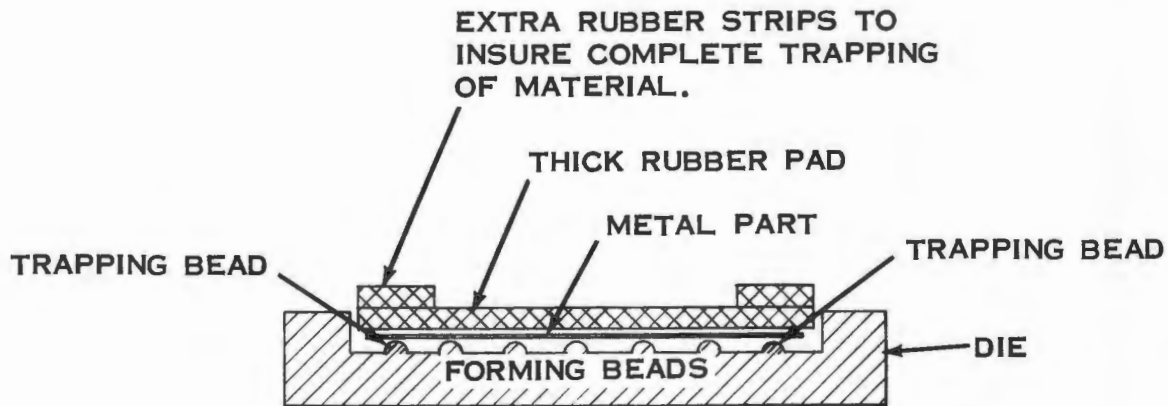

FIGURE VI B-3 CROSS SECTION OF A DROP HAMMER DIE.

All beaded panels were formed with complete "trapping". It can be seen from the illustration in Figure VIB-2, that the drop hammer die has a continuous bead which completely surrounds the bead forming area. This continuous bead is known as a "trapping" bead. That is, the bead completely traps the metal part around the outside perimeter of the forming area. This is done so that only the metal inside the trapped perimeter is allowed to draw or stretch over the beads inside. This type of trapping is selected for evaluation in this process because of the maximum strain the metal part must undergo to be formed into shape.

This full or complete trapping procedure is accomplished by placing extra strips of hard rubber over the top of the trapped bead. (See Figure VI B-3) Thus on the first blow from the hammer ram, complete trapping occurs. These extra strips of rubber are used continuously to insure proper trapping during the entire forming process.

Drop hammer forming is very much an "operator technique" forming operation. That is, the operator usually has his own method of technique to use in forming a part. That is why, in this investigation, the forming procedures were held as constant as possible so as to minimize the operator technique factor.

Results obtained in this program establish that formability of the drop hammer bead forming process can definitely be predicted from the geometrical parameters of the dies and the material properties of a selected material.

Definition of Part Shape
and Geometrical Variables

Formability of drop hammer beaded panels is governed by the following geometrical parameters: Bead radius of the die (R), the length of space between the center line of the beads (L), the gage of the material (t), R/L and R/t . (r) is a selected radius of the female punch. This (r) radius was selected at $1/2''$ in order to allow protection from failure due to the minimum bend radius of a selected material. These parameters are shown in the following sketch:

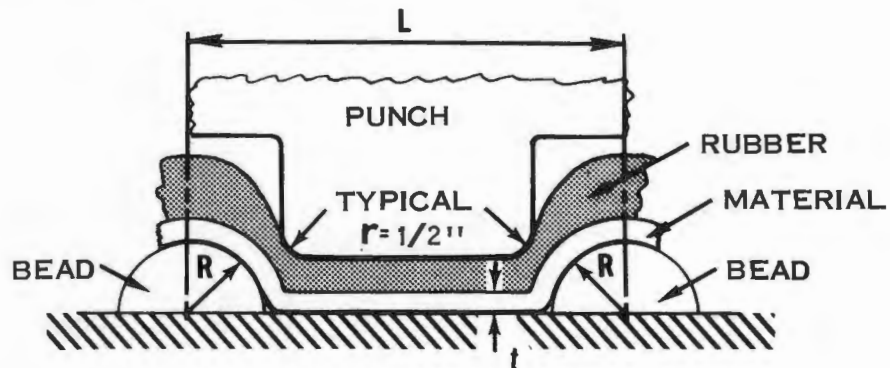

FIGURE VI B-4 GEOMETRICAL PARAMETERS.

Two standard bead radii were selected for evaluation purposes. These radii were $1/2''$ and $1''$ respectfully.

The die radius was held constant while varying only the (L) length between the centerline of the beads. This yielded various combinations of R/L and R/t for evaluation purposes.

There is an upper forming limit for R/L governed by the physical spacing of the beads. That is, the beads are so close together that it is physically impossible to form a part as the bead spacing approaches $R/L = .35$. This is readily seen from the following sketch:

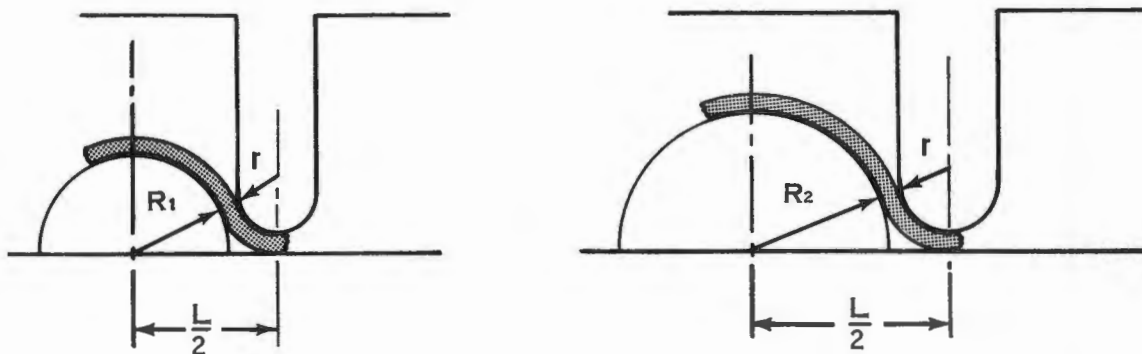

FIGURE VI B-5 RELATIONSHIP OF BEAD SPACING.

As (R) increases (L) has to increase also. Since (r) is a standard $1/2''$, the female punch has to be a minimum of $1''$. Thus, as R/L approaches .35 the bead spacing (L) will close and not allow proper clearance for the female punch and the material thickness.

There is also a lower limit based upon the minimum radius and maximum (L) which is effective as far as the stiffness of the beaded panel is concerned. In other words at an (R) of 0.5 and an (L) of approximately 8 inches, the structural efficiency of the panel is lowered considerably. Therefore, in general, beaded panels below $R/L = .060$ would result in lowering of the structural efficiency of the panel.

Minimum bend failures occurred in the drop hammer process for HM21XA-T8 Magnesium Thorium, (6Al-4V) Titanium, and (13V-11Cr-3Al) Titanium.

Minimum bend radii of these materials are 5t, 6t, and 3t respectively. It can be seen from the following sketch of a bead, there is a very sharp radius that will not allow these three problem materials to form properly.

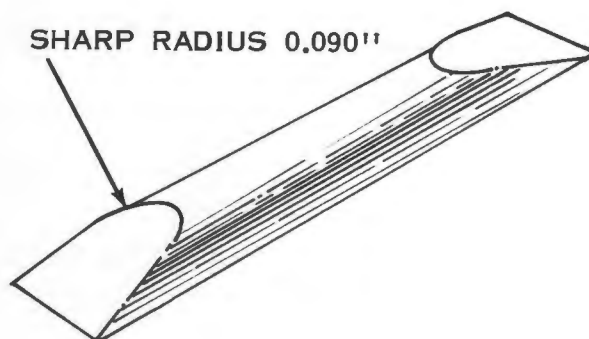

FIGURE VI B-6 BEAD.

On the initial blow from the drop hammer ram, the material is forced down around this sharp radius and exceeds the minimum bend radius of the material. Thus, splitting occurs at the radius and propagates across the bead. Due to this standard bead radius of .090" it is impossible to form these materials at room temperature.

Predictability Equations

The equation for the splitting limit of any material based on its mechanical properties is:

$$\frac{R}{L} = 60.6(\epsilon_{.50}(\text{CORR.}))^2 \left(\frac{R}{t}\right)^{-1} \quad \text{Equation I}$$

The equation for the index line is:

$$\frac{R}{L} = .0165 \left(\frac{R}{t}\right) \text{ or, } \frac{R}{t} = 60.6 \left(\frac{R}{L}\right) \quad \text{Equation II}$$

The index line has a slope of + 1 and intersects at a point $R/t = 2$, $R/L = .033$.

For the convenience of reference to the above mentioned equations, a typical theoretical formability curve for drop hammer is shown in Figure VI B-7.

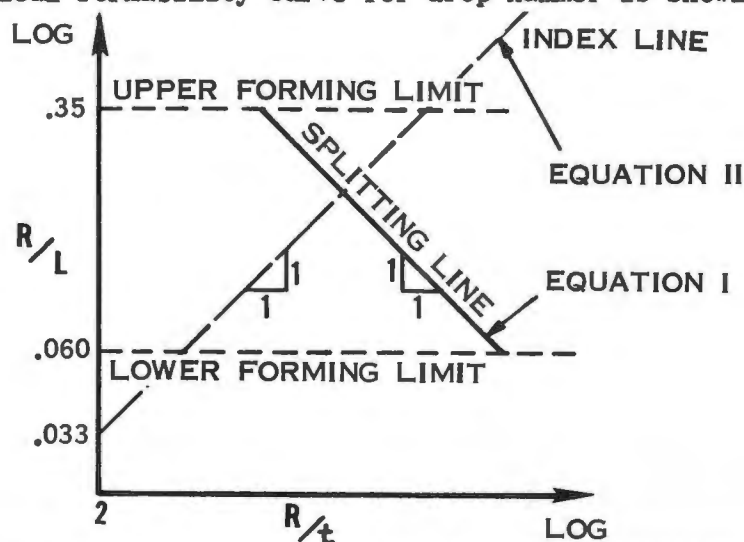

FIGURE VI B-7 TYPICAL DROP HAMMER FORMABILITY CURVE.

The key to using the various equations is to know the following material property.

$\epsilon_{.50}(\text{CORR.}) =$ Where,

$$\epsilon_{.50}(\text{CORR.}) = \ln^{-1} \left[[\bar{\epsilon}_L]_{.50} - \frac{[\bar{\epsilon}_W]_{.50}^2}{[\bar{\epsilon}_L]_{.50}} \right] - 1$$

$\epsilon_{.50}(\text{CORR.})$ is found from a standard 1/2" wide tensile specimen.

With the aid of the sketch in Figure VI B-8, it can be seen where the various measurements were taken by a Cathetometer.

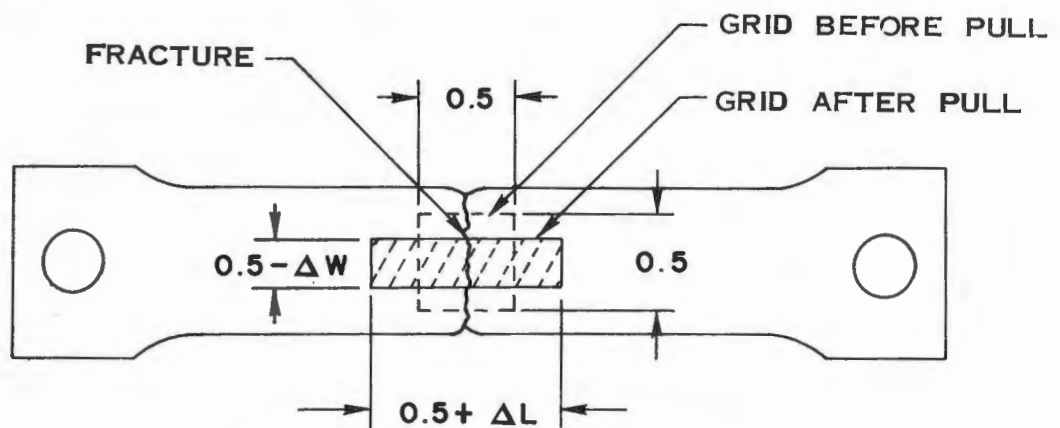

FIGURE VI B-8 1/2" WIDE TENSILE SPECIMEN.

$$[\epsilon_L]_{.5} = \frac{\Delta L}{0.5}$$

$$[\bar{\epsilon}_L]_{.5} = \ln [1 + (\epsilon_L)_{.5}]$$

$$\epsilon_W .5 = \frac{\Delta W}{0.5}$$

$$[\bar{\epsilon}_W]_{.5} = \ln [1 + (\epsilon_W)_{.5}]$$

Thus, the value of the various measurements can be substituted into the original equation to solve for the $\epsilon_{.50}(\text{CORR.})$ corrected value.

Thus if $\epsilon_{.50}(\text{CORR.})$ is known, the drop hammer formability of any material can be determined.

To demonstrate how to use the drop hammer predictability equations, the following example problem is given:

PROBLEM: Find the splitting limits for drop hammer forming 2024-O aluminum.

GIVEN: $\epsilon_{.50}(\text{CORR.}) = \underline{.200}$
 R (radius of bead on die) = $1/2''$
 t (gage of material) = 0.020 $R/t = 25$

SOLUTION: Step I. Select the R/t value from the die bead radius (R) and the gage of material (t). Substitute in the $R/t = 25$ value into Equation II and solve for R/L intercept.

$$R/L = 60.6 (\epsilon_{.50}(\text{CORR.}))^2 (R/t)^{-1} = \underline{.097}$$

Now, locate $R/L = .097$ value on R/L scale and go over to the intersection of the $R/t = 25$ line. This gives a point at $R/L = .097$ and $R/t = 25$. Through this point draw a -1 slope. See Figure VI B-9.

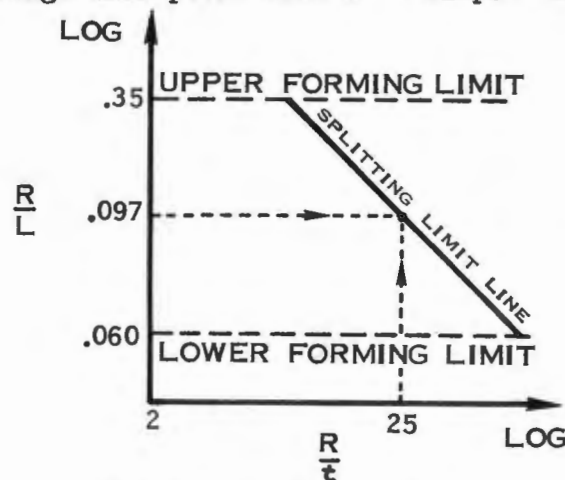

FIGURE VI B-9 GRAPH CONSTRUCTION.

Thus, the splitting limit line is established for 2024-O aluminum.

An alternate method that can be used is as follows:

Step I. Use the relationship $\epsilon_{.50}(\text{CORR.}) = R/L$

Thus, $\epsilon_{.50}(\text{CORR.})$ and $R/L = \underline{.200}$.

Step II. The index line is a + 1 slope and intersects at a point $R/t = 2$, $R/L = .033$. Simply locate $R/L = .200$ on the R/L axis, then go over to the intersection of this R/L value on the index line. (See Figure VIB-10). Now draw a -1 slope through this intersection point and the splitting limit is established.

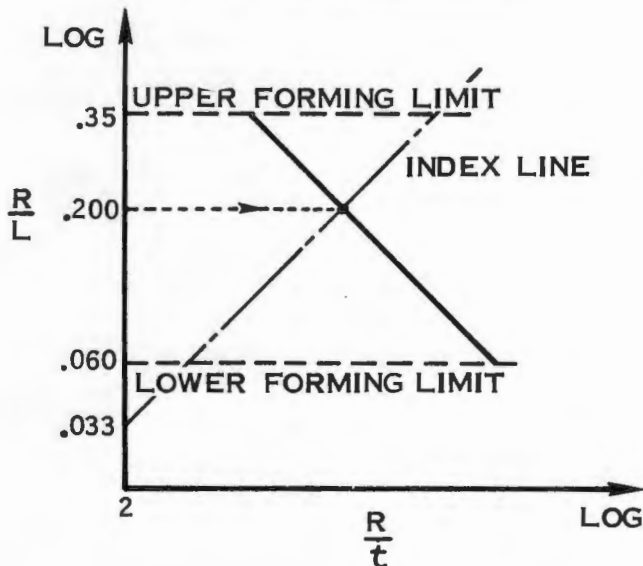

FIGURE VI B-10 GRAPH CONSTRUCTION.

These two methods yield the splitting limit line for 2024-O aluminum. Any part formed to the right of the splitting limit line will fail due to splitting and any part formed to the left of the splitting limit line will yield a good part.

The following typical formability curve for drop hammer forming of beaded panels is shown in Figure VI B-11.

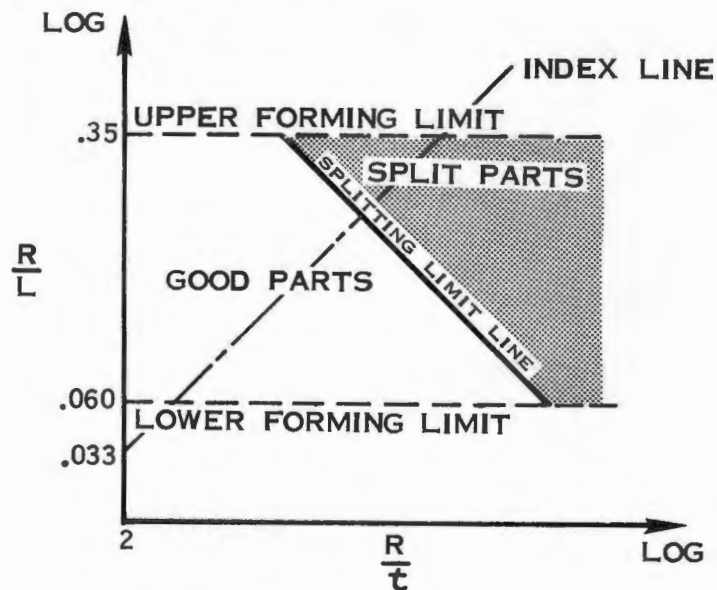

FIGURE VI B-11 TYPICAL FORMABILITY ENVELOPE.

Composite Graphs

A composite graph showing the drop hammer formability of 12 different materials used in this program is shown in Graph VI B-1. All materials are shown at room temperature.

Formability evaluations for HM21XA-T8, (6Al-4V) Titanium and (13V-11Cr-3Al) Titanium were also evaluated in the drop hammer process. However, due to the minimum bend radius failure for these materials, results are not recorded in the composite graphs.

It should be understood that the material property $\epsilon_{.50}(\text{CORR.})$ used in predicting drop hammer formability curves, will have a maximum, average and minimum value depending upon the material properties of the material in which the tensile specimens were taken. This variation in $\epsilon_{.50}(\text{CORR.})$ will affect the splitting limit of a selected material. This is illustrated in the following sketch.

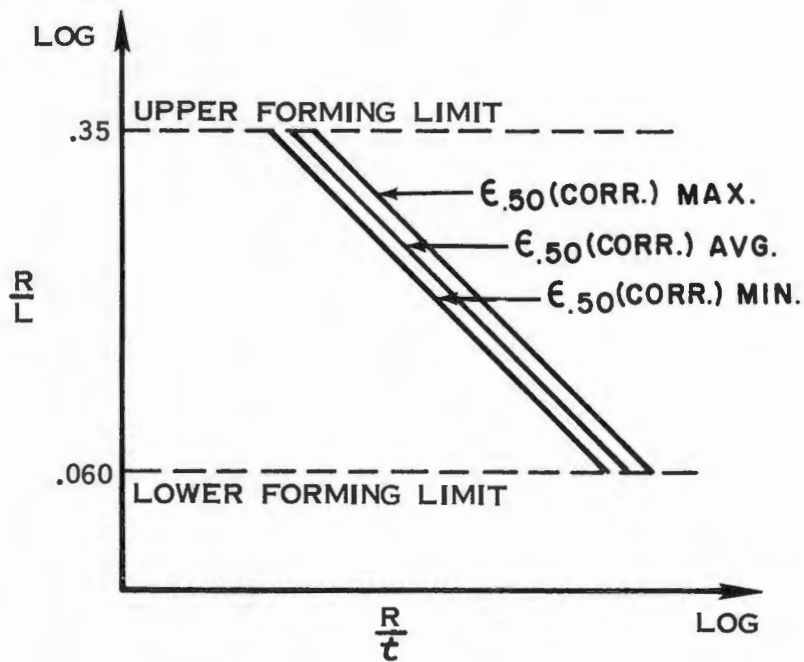

FIGURE VI B-12 VARIATION OF MATERIAL PROPERTIES.

It can be seen that the composite Graph VIB-1 was constructed on a logarithmic basis. However, for the convenience of finding the radius of the bead (R) and the distance between the beads (L) for a certain material thickness (t), an alternate method is advised.

This is done by taking a certain material (2024-0 aluminum) from the logarithmic composite graph (Graph VIB-1) and re-plotting the information on a Cartesian coordinate graph. (See Graph VI B-2). Thus, the values of R, L and t can be read directly from this type of graph (Graph VI B-2).

Formability evaluations for Molybdenum (.5% Ti), Tungsten (pure), Columbium (10 Mo - 10 Ti), and Beryllium (pure) were also performed in this program. However, these materials are not recorded in the composite graph and design tables due to the bending failure of these materials on the sharp end radius of the standard bead. (See discussion under geometrical variables).

Elevated temperature results are also not recorded, due to being unable to read the grids on the elevated temperature tensile specimens.

GRAPH VI B-1
 COMPOSITE GRAPH FOR
 DROP HAMMER BEADED PANELS

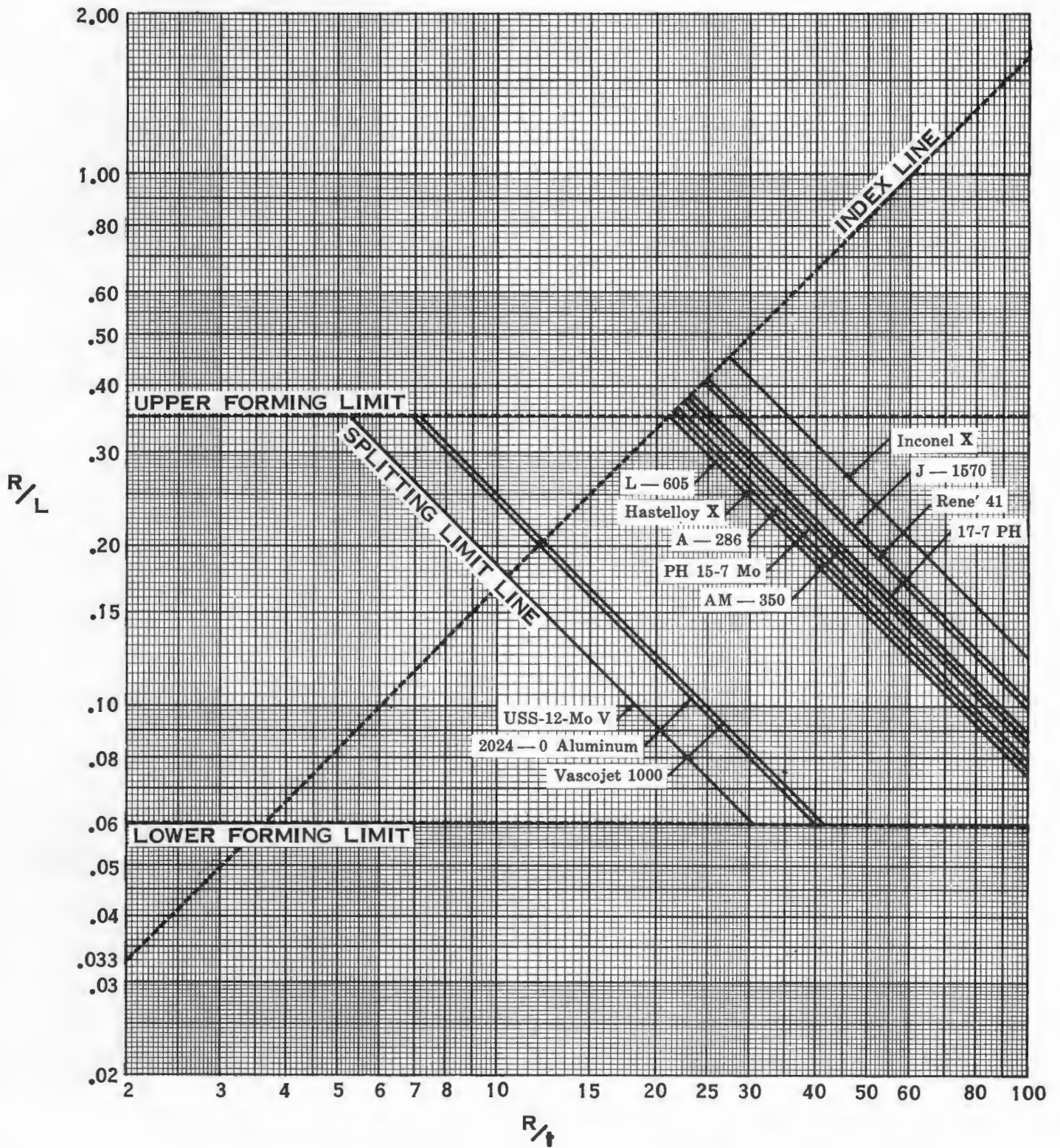

GRAPH VI B-2
DROP HAMMER BEAD LIMITS
2024-O ALUMINUM

ASD TR 61-191 (II)

VI-1A

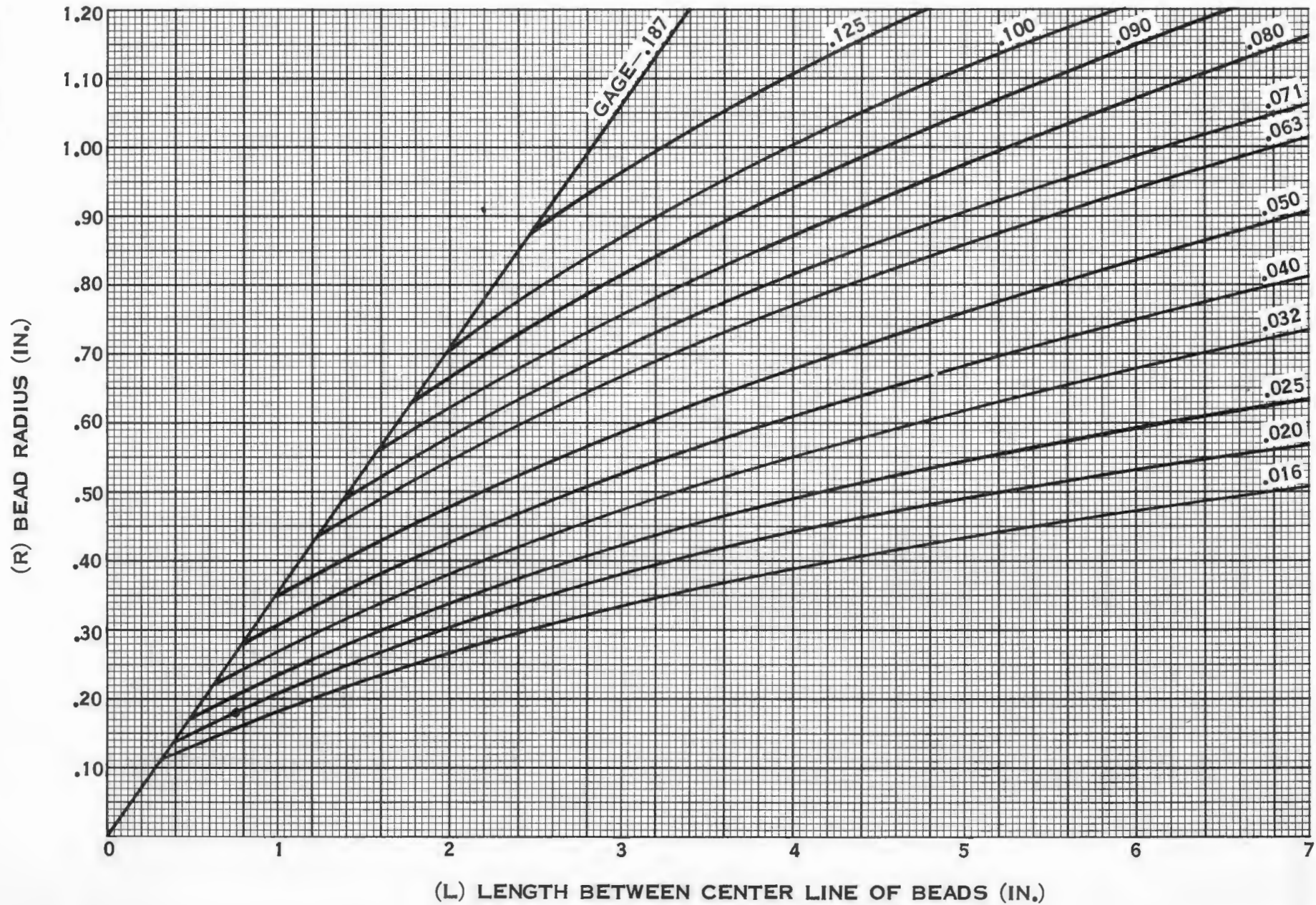

Design Tables

The design tables are established to provide recommended geometrical parameters for forming beaded panels by the drop hammer process. These tables are arranged to provide recommended values of (L) the distance between the center line of the beads for a certain (R) bead radius and (t) gage of material. (See Figure VI B-4).

The design tables are based on using a minimum female punch of 1". Since 0.020", 0.040" and 0.063" gage material was used for evaluation purposes on all dies, a 1/2" standard punch radius was necessary to insure protection against minimum bend failure. It can be readily seen from the following illustration that when using the 1/2" punch radius, the web or width of the punch must be a 1" minimum.

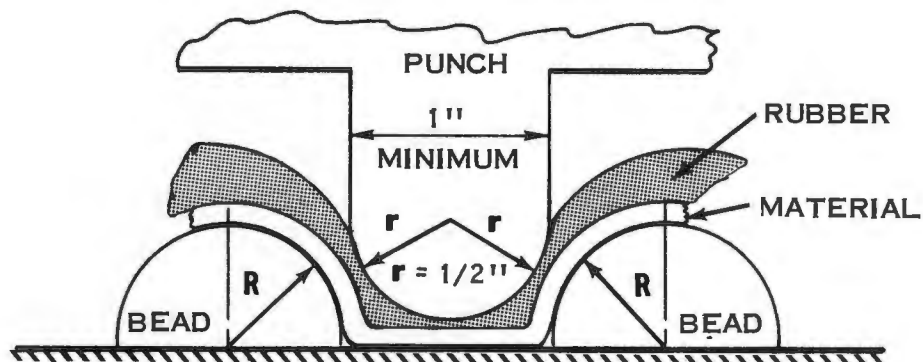

FIGURE VI B-13 SCHEMATIC OF A PUNCH AND BEAD.

The design tables will have vacant sections due to the bead spacing (L) being too close to allow this 1" punch radius to properly clear the material and the beads.

The design tables are used in the following manner: For a given (t) gage of material and a given (R) radius of bead, there is a corresponding selected (L) length between the center line of the beads. Thus, by having a given (t) and a given (R) the recommended (L) can be read from the tables. Or, by having a given (L) and a given (t) the recommended (R) can be read from the tables. These tables are recorded in the following section.

TABLE VI B-1
 DROP HAMMER BEAD LIMITS
 2024-O ALUMINUM

GAGE (t)	.016	.020	.025	.032	.040	.050	.063	.071	.080	.090	.100	.125	.187
RADIUS (R)	(L) Distance Between Center Line of Beads												
0.30	2.5	1.9	1.65	1.66	1.68	1.70	1.73	1.74	1.76	1.78	1.80	1.85	1.97
0.35	3.4	2.7	2.1	1.76	1.78	1.80	1.83	1.84	1.86	1.88	1.90	1.95	2.07
0.40	4.3	3.5	2.8	2.2	1.88	1.90	1.93	1.94	1.96	1.98	2.00	2.05	2.17
0.45	5.5	4.4	3.6	2.7	2.2	2.00	2.03	2.04	2.06	2.08	2.10	2.15	2.27
0.50	6.8	5.4	4.3	3.3	2.7	2.20	2.13	2.14	2.16	2.18	2.20	2.25	2.37
0.60	9.8	7.9	6.2	5.0	3.9	3.1	2.5	2.34	2.36	2.38	2.40	2.45	2.57
0.70		10.6	8.5	6.8	5.4	4.2	3.3	3.0	2.6	2.58	2.60	2.65	2.77
0.80			11.1	8.7	7.1	5.5	4.4	3.9	3.5	3.1	2.80	2.85	2.97
0.90			14.3	11.0	9.0	7.2	5.5	5.0	4.4	3.9	3.5	3.05	3.17
1.00				13.5	10.9	8.8	6.7	6.1	5.4	4.8	4.4	3.4	3.37

TABLE VI B-2
 DROP HAMMER BEAD LIMITS
 17-7 PH STAINLESS STEEL
 (CONDITION "A")

GAGE (t)	.016	.020	.025	.032	.040	.050	.063	.071	.080	.090	.100	.125	.187
RADIUS (R)	(L) Distance Between Center Line of Beads												
0.30	1.63	1.64	1.65	1.66	1.68	1.70	1.73	1.74	1.76	1.78	1.80	1.85	1.97
0.35	1.73	1.74	1.75	1.76	1.78	1.80	1.83	1.84	1.86	1.88	1.90	1.95	2.07
0.40	1.83	1.84	1.85	1.86	1.88	1.90	1.93	1.94	1.96	1.98	2.00	2.05	2.17
0.45	1.93	1.94	1.95	1.96	1.98	2.00	2.03	2.04	2.06	2.08	2.10	2.15	2.22
0.50	2.03	2.04	2.05	2.06	2.08	2.10	2.13	2.13	2.16	2.18	2.20	2.25	2.37
0.60	2.8	2.2	2.15	2.26	2.28	2.30	2.33	2.33	2.36	2.38	2.40	2.45	2.57
0.70	3.8	3.0	2.4	2.46	2.48	2.50	2.53	2.54	2.56	2.58	2.60	2.65	2.77
0.80	5.0	4.0	3.2	2.66	2.68	2.70	2.73	2.74	2.76	2.78	2.80	2.85	2.97
0.90	6.2	5.0	4.0	3.1	2.88	2.90	2.93	2.94	2.96	2.98	3.00	3.05	3.17
1.00	8.0	6.2	5.0	3.8	3.1	3.10	3.13	3.14	3.16	3.18	3.20	3.25	3.37

TABLE VI B-3
 DROP HAMMER BEAD LIMITS
 PH 15-7 Mo STAINLESS STEEL
 (MILL ANNEALED, CONDITION "A")

GAGE (t)	.016	.020	.025	.032	.040	.050	.063	.071	.080	.090	.100	.125	.187
RADIUS (R)	(L) Distance Between Center Line of Beads												
0.30	1.63	1.64	1.65	1.66	1.68	1.70	1.73	1.74	1.76	1.78	1.80	1.85	1.97
0.35	1.73	1.74	1.75	1.76	1.78	1.80	1.83	1.84	1.86	1.88	1.90	1.95	2.07
0.40	1.83	1.84	1.85	1.86	1.88	1.90	1.93	1.94	1.96	1.98	2.00	2.05	2.17
0.45	1.93	1.94	1.95	1.96	1.98	2.00	2.03	2.04	2.06	2.08	2.10	2.15	2.22
0.50	2.03	2.04	2.05	2.06	2.08	2.10	2.13	2.13	2.16	2.18	2.20	2.25	2.37
0.60	2.8	2.2	2.15	2.26	2.28	2.30	2.33	2.33	2.36	2.38	2.40	2.45	2.57
0.70	3.8	3.0	2.4	2.46	2.48	2.50	2.53	2.54	2.56	2.58	2.60	2.65	2.77
0.80	5.0	4.0	3.2	2.66	2.68	2.70	2.73	2.74	2.76	2.78	2.80	2.85	2.97
0.90	6.2	5.0	4.0	3.1	2.88	2.90	2.93	2.94	2.96	2.98	3.00	3.05	2.17
1.00	8.0	6.2	5.0	3.8	3.1	3.10	3.13	3.14	3.16	3.18	3.20	3.25	3.37

TABLE VI B-4
 DROP HAMMER BEAD LIMITS
 AM-350 STAINLESS STEEL
 (ANNEALED)

GAGE (t)	.016	.020	.025	.032	.040	.050	.063	.071	.080	.090	.100	.125	.187
RADIUS (R)	(L) Distance Between Center Line of Beads												
0.30	1.63	1.64	1.65	1.66	1.68	1.70	1.73	1.74	1.76	1.78	1.80	1.85	1.97
0.35	1.73	1.74	1.75	1.76	1.78	1.80	1.83	1.84	1.86	1.88	1.90	1.95	2.07
0.40	1.83	1.84	1.85	1.86	1.88	1.90	1.93	1.94	1.96	1.98	2.00	2.05	2.17
0.45	1.93	1.94	1.95	1.96	1.98	2.00	2.03	2.04	2.06	2.08	2.10	2.15	2.22
0.50	2.03	2.04	2.05	2.06	2.08	2.10	2.13	2.13	2.16	2.18	2.20	2.25	2.37
0.60	2.8	2.2	2.15	2.26	2.28	2.30	2.33	2.33	2.36	2.38	2.40	2.45	2.57
0.70	3.8	3.0	2.4	2.46	2.48	2.50	2.53	2.54	2.56	2.58	2.60	2.65	2.77
0.80	5.0	4.0	3.2	2.66	2.68	2.70	2.73	2.74	2.76	2.78	2.80	2.85	2.97
0.90	6.2	5.0	4.0	3.1	2.88	2.90	2.93	2.94	2.96	2.98	3.00	3.05	3.17
1.00	8.0	6.2	5.0	3.8	3.1	3.10	3.13	3.14	3.16	3.18	3.20	3.25	3.37

TABLE VI B-5
 DROP HAMMER BEAD LIMITS
 A-286 STAINLESS STEEL
 (SOLUTION TREATED CONDITION)

GAGE (t)	.016	.020	.025	.032	.040	.050	.063	.071	.080	.090	.100	.125	.187
RADIUS (R)	(L) Distance Between Center Line of Beads												
0.30	1.63	1.64	1.65	1.66	1.68	1.70	1.73	1.74	1.76	1.78	1.80	1.85	1.97
0.35	1.73	1.74	1.75	1.76	1.78	1.80	1.83	1.84	1.86	1.88	1.90	1.95	2.07
0.40	1.83	1.84	1.85	1.86	1.88	1.90	1.93	1.94	1.96	1.98	2.00	2.05	2.17
0.45	1.93	1.94	1.95	1.96	1.98	2.00	2.03	2.04	2.06	2.08	2.10	2.15	2.27
0.50	2.03	2.04	2.05	2.06	2.08	2.10	2.13	2.14	2.16	2.18	2.20	2.25	2.37
0.60	2.9	2.3	2.25	2.26	2.28	2.30	2.33	2.34	2.36	2.38	2.40	2.45	2.57
0.70	4.0	3.2	2.5	2.46	2.48	2.50	2.53	2.54	2.56	2.58	2.60	2.65	2.77
0.80	5.2	4.2	3.3	2.6	2.68	2.70	2.73	2.74	2.76	2.78	2.80	2.85	2.97
0.90	6.4	5.3	4.2	3.3	2.88	2.90	2.93	2.94	2.96	2.98	3.00	3.05	3.17
1.00	7.7	6.4	5.3	4.1	3.2	3.10	3.13	3.14	3.16	3.98	3.20	3.15	3.37

TABLE VI B-6
 DROP HAMMER BEAD LIMITS
 USS-12-MoV STAINLESS STEEL
 (ANNEALED)

GAGE (t)	.016	.020	.025	.032	.040	.050	.063	.071	.080	.090	.100	.125	.187
RADIUS (R)	(L) Distance Between Center Line of Beads												
0.30	3.0	2.4	1.9	1.66	1.68	1.70	1.73	1.74	1.75	1.78	1.80	1.85	1.97
0.35	4.0	3.2	2.6	2.0	1.78	1.80	1.83	1.84	1.86	1.88	1.90	1.95	2.07
0.40	5.3	4.2	3.4	2.6	2.1	1.90	1.93	1.94	1.96	1.98	2.00	2.05	2.17
0.45	6.7	5.3	4.3	3.3	2.6	2.1	2.03	2.04	2.06	2.08	2.10	2.15	2.27
0.50	8.3	6.6	5.2	4.2	3.3	2.6	2.1	2.14	2.16	2.18	2.20	2.25	2.37
0.60		9.7	7.6	6.0	4.8	3.8	3.0	2.7	2.3	2.38	2.40	2.45	2.57
0.70			10.4	8.8	6.7	5.3	4.1	3.7	3.2	2.9	2.60	2.65	2.97
0.80			13.4	10.5	8.5	6.8	5.4	4.7	4.2	3.7	3.4	2.85	2.97
0.90				13.6	10.7	8.8	6.9	6.1	5.4	4.7	4.3	3.4	3.17
1.00				16.7	13.2	10.4	8.3	7.7	6.7	6.0	5.2	4.3	3.37

TABLE VI B-7
 DROP HAMMER BEAD LIMITS
 VASCOJET 1000 (H-11)
 (ANNEALED.)

GAGE (t)	.016	.020	.025	.032	.040	.050	.063	.071	.080	.090	.100	.125	.187
RADIUS (R)	(L) Distance Between Center Line of Beads												
0.30	2.5	1.9	1.65	1.66	1.68	1.70	1.73	1.74	1.76	1.78	1.80	1.85	1.97
0.35	3.4	2.7	2.1	1.76	1.78	1.80	1.83	1.84	1.86	1.88	1.90	1.95	2.07
0.40	4.3	3.5	2.8	2.2	1.88	1.90	1.93	1.94	1.96	1.98	2.00	2.05	2.17
0.45	5.5	4.4	3.6	2.7	2.2	2.00	2.03	2.04	2.06	2.08	2.10	2.15	2.27
0.50	6.8	5.4	4.3	3.3	2.7	2.20	2.13	2.14	2.16	2.18	2.20	2.25	2.37
0.60	9.8	7.9	6.2	5.0	3.9	3.1	2.5	2.34	2.36	2.38	2.40	2.45	2.57
0.70		10.6	8.5	6.8	5.4	4.2	3.3	3.0	2.6	2.58	2.60	2.65	2.77
0.80			11.1	8.7	7.1	5.5	4.4	3.9	3.5	3.1	2.80	2.85	2.97
0.90			14.3	11.0	9.0	7.2	5.5	5.0	4.4	3.9	3.5	3.05	3.17
1.00				13.5	10.9	8.8	6.7	6.1	5.4	4.8	4.4	3.4	3.37

TABLE VI B-8
 DROP HAMMER BEAD LIMITS
 RENE '41
 (SOLUTION TREATED)

GAGE (t)	.016	.020	.025	.032	.040	.050	.063	.071	.080	.090	.100	.125	.187
RADIUS (R)	(L) Distance Between Center Line of Beads												
0.30	1.63	1.64	1.65	1.66	1.68	1.70	1.73	1.74	1.76	1.78	1.80	1.85	1.97
0.35	1.73	1.74	1.75	1.76	1.78	1.80	1.83	1.84	1.86	1.88	1.90	1.95	2.07
0.40	1.83	1.84	1.85	1.86	1.88	1.90	1.93	1.94	1.96	1.98	2.00	2.05	2.17
0.45	1.93	1.94	1.95	1.96	1.98	2.00	2.03	2.04	2.06	2.08	2.10	2.15	2.27
0.50	2.03	2.04	2.05	2.06	2.08	2.10	2.13	2.14	2.16	2.18	2.20	2.25	2.37
0.60	2.3	2.24	2.25	2.26	2.28	2.30	2.33	2.34	2.36	2.38	2.40	2.45	2.57
0.70	3.2	2.5	2.45	2.46	2.48	2.50	2.53	2.54	2.56	2.58	2.60	2.65	2.77
0.80	4.2	3.3	2.7	2.66	2.68	2.70	2.73	2.74	2.76	2.78	2.80	2.85	2.97
0.90	5.3	4.2	3.4	2.86	2.88	2.90	2.93	2.94	2.96	2.98	3.00	3.05	3.17
1.00	6.9	5.3	4.2	3.1	3.08	3.10	3.13	3.14	3.16	3.08	3.20	3.25	3.37

TABLE VI B-9
 DROP HAMMER BEAD LIMITS
 INCONEL X
 (C. R. ANNEALED)

GAGE (t)	.016	.020	.025	.032	.040	.050	.063	.071	.080	.090	.100	.125	.187
RADIUS (R)	(L) Distance Between Center Line of Beads												
0.30	1.63	1.64	1.65	1.66	1.68	1.70	1.73	1.74	1.76	1.78	1.80	1.85	1.97
0.35	1.73	1.74	1.75	1.76	1.78	1.80	1.83	1.84	1.86	1.88	1.90	1.95	2.07
0.40	1.83	1.84	1.85	1.86	1.88	1.90	1.93	1.94	1.96	1.98	2.00	2.05	2.17
0.45	1.93	1.94	1.95	1.96	1.98	2.00	2.03	2.04	2.06	2.08	2.10	2.15	2.27
0.50	2.03	2.04	2.05	2.05	2.08	2.10	2.13	2.14	2.16	2.18	2.20	2.25	2.37
0.60	2.23	2.24	2.25	2.26	2.28	2.30	2.33	2.34	2.36	2.38	2.40	2.45	2.57
0.70	2.5	2.44	2.45	2.46	2.48	2.50	2.53	2.54	2.56	2.58	2.60	2.65	2.77
0.80	3.3	3.0	2.65	2.66	2.68	2.70	2.73	2.74	2.76	2.78	2.80	2.85	2.97
0.90	4.3	3.4	2.85	2.86	2.88	2.90	2.93	2.94	2.96	2.98	3.00	3.05	3.17
1.00	5.3	4.2	3.8	3.06	3.08	3.10	3.13	3.14	3.16	3.18	3.20	3.25	3.37

TABLE VI B-10
 DROP HAMMER BEAD LIMITS
 HASTELLOY X
 (SOLUTION TREATED)

GAGE (t)	.016	.020	.025	.032	.040	.050	.063	.071	.080	.090	.100	.125	.187
RADIUS (R)	(L) Distance Between Center Line of Beads												
0.30	1.63	1.64	1.65	1.66	1.68	1.70	1.73	1.74	1.76	1.78	1.80	1.85	1.97
0.35	1.73	1.74	1.75	1.76	1.78	1.80	1.83	1.84	1.86	1.88	1.90	1.95	2.07
0.40	1.83	1.84	1.85	1.86	1.88	1.90	1.93	1.94	1.96	1.98	2.00	2.05	2.17
0.45	1.93	1.94	1.95	1.96	1.98	2.00	2.03	2.04	2.06	2.08	2.10	2.15	2.27
0.50	2.2	2.04	2.05	2.06	2.08	2.10	2.13	2.14	2.16	2.18	2.20	2.25	2.37
0.60	3.1	2.5	2.25	2.26	2.28	2.30	2.33	2.34	2.36	2.38	2.40	2.45	2.57
0.70	4.2	3.4	2.7	2.46	2.48	2.56	2.53	2.54	2.56	2.58	2.60	2.65	2.77
0.80	5.7	4.4	3.6	2.8	2.68	2.70	2.73	2.74	2.76	2.78	2.80	2.85	2.97
0.90	7.2	5.6	4.5	3.5	2.88	2.90	2.93	2.94	2.96	2.98	3.00	3.05	3.17
1.00	8.8	7.1	5.6	4.4	3.4	3.10	3.13	3.14	3.16	3.18	3.20	3.25	3.37

TABLE VI B-11
 DROP HAMMER BEAD LIMITS
 L-605
 (SOLUTION TREATED)

GAGE (t)	.016	.020	.025	.032	.040	.050	.063	.071	.080	.090	.100	.125	.187
RADIUS (R)	(L) Distance Between Center Line of Beads												
0.30	1.63	1.64	1.65	1.66	1.68	1.70	1.73	1.74	1.76	1.78	1.80	1.85	1.97
0.35	1.73	1.74	1.75	1.76	1.78	1.80	1.83	1.84	1.86	1.88	1.90	1.95	2.07
0.40	1.83	1.84	1.85	1.86	1.88	1.90	1.93	1.94	1.96	1.98	2.00	2.05	2.17
0.45	1.93	1.94	1.95	1.96	1.98	2.00	2.03	2.04	2.06	2.08	2.10	2.15	2.27
0.50	2.2	2.04	2.05	2.06	2.08	2.10	2.13	2.14	2.16	2.18	2.20	2.25	2.37
0.60	3.1	2.5	2.25	2.26	2.28	2.30	2.33	2.34	2.36	2.38	2.40	2.45	2.57
0.70	4.2	3.4	2.7	2.46	2.48	2.56	2.53	2.54	2.56	2.58	2.60	2.65	2.77
0.80	5.7	4.4	3.5	2.8	2.68	2.70	2.73	2.74	2.76	2.78	2.80	2.85	2.97
0.90	7.2	5.6	4.5	3.5	2.88	2.90	2.93	2.94	2.96	2.98	3.00	3.05	3.17
1.00	8.8	7.1	5.6	4.4	3.4	3.10	3.13	3.14	3.16	3.18	3.20	3.25	3.37

TABLE VI B-12
 DROP HAMMER BEAD LIMITS
 J-1570
 (SOLUTION TREATED)

GAGE (t)	.016	.020	.025	.032	.040	.050	.063	.071	.080	.090	.100	.125	.187
RADIUS (R)	(L) Distance Between Center Line of Beads												
0.30	1.63	1.64	1.65	1.66	1.68	1.70	1.73	1.74	1.76	1.78	1.80	1.85	1.97
0.35	1.73	1.74	1.75	1.76	1.78	1.80	1.83	1.84	1.86	1.88	1.90	1.95	2.07
0.40	1.83	1.84	1.85	1.86	1.88	1.90	1.93	1.94	1.96	1.98	2.00	2.05	2.17
0.45	1.93	1.94	1.95	1.96	1.98	2.00	2.03	2.04	2.05	2.08	2.10	2.15	2.27
0.50	2.03	2.04	2.05	2.06	2.08	2.10	2.13	2.14	2.16	2.18	2.20	2.25	2.37
0.60	2.3	2.24	2.25	2.26	2.28	2.30	2.33	2.34	2.36	2.38	2.40	2.45	2.57
0.70	3.2	2.5	2.45	2.46	2.48	2.50	2.53	2.54	2.56	2.58	2.60	2.65	2.77
0.80	4.2	3.3	2.7	2.66	2.68	2.70	2.73	2.74	2.76	2.78	2.80	2.85	2.97
0.90	5.3	4.2	3.4	2.86	2.88	2.90	2.93	2.94	2.96	2.98	3.00	3.05	3.17
1.00	6.9	5.3	4.2	3.1	3.08	3.10	3.13	3.14	3.16	3.08	3.20	3.25	3.37