

WADC TECHNICAL REPORT 53-19

**DEVELOPMENT OF A PRACTICAL LABORATORY PROCEDURE TO  
BE USED IN EVALUATING THE FORMING QUALITIES  
OF PLASTIC SHEET MATERIALS**

*Paul H. Kaar*

*Armour Research Foundation*

*September 1953*

*Materials Laboratory*

*Contract No. AF33(038)-27648*

*RDO No. 616-12*

Wright Air Development Center  
Air Research and Development Command  
United States Air Force  
Wright-Patterson Air Force Base, Ohio

# Contrails

## FOREWORD

This is the final report prepared by Armour Research Foundation under USAF Contract AF 33(038)-27648. The contract was initiated under Research and Development Order No. 616-12, "Transparent Materials," and was administered by the Materials Laboratory, Directorate of Research, Wright Air Development Center with Lt R. C. Smith acting as project engineer. The work outlined herein was done during the period extending from January 1952 to January 1953.

Foundation personnel who have contributed to this report include:

E. L. Chez, E. G. Filetti, C. A. Fischl, E. Frank, S. J. Fraenkel, P. H. Kaar, and W. T. Savage.

This report includes data and comments taken from a summary report written by Dr. S. J. Fraenkel, dated September 30, 1952.

# Contrails

## ABSTRACT

Under the terms of the contract with Wright Air Development Center, the purpose of this research project was (1) to study the various factors which are of importance in the fabrication of flat plastic sheet material into useful shapes for a transparent aircraft enclosure, and (2) to develop a practical laboratory procedure for evaluating the forming qualities of these plastic materials. In order to achieve this objective, it was necessary to review the industrial processes and applications of the material and to determine what measurable characteristics are important in forming operations.

Generally, the investigation of a formability criterion proceeded along two separate lines. One approach was an attempt to use various standardized engineering test procedures to indicate formability. The other approach was to duplicate various manufacturers' forming operations and use data derived from these tests to evaluate forming characteristics. Apparatus development was a significant part of each approach.

This final report includes discussions and data pertinent to the selection of the formability criterion recommended and a discussion of the important factors in formability evaluation.

The formability rating system recommended consists of forming, by positive air pressure, an unconfined bubble of the plastic heated to optimum forming temperature. The rating assigned is based on the pressure required to form the bubble and the extent to which it can be formed before fracture. Plastics incapable of being stretched are rated by a bend test. Conclusions reached are as follows:

# Contrails

1. A suitable formability criterion for transparent plastic sheet must embody evaluation of (1) ease of forming and (2) maximum extent of forming possible.

2. Standardized engineering tests performed at optimum forming temperature and providing such data as maximum elongation, creep, and ball penetration values fail to evaluate formability satisfactorily for the following reasons:

a. Data from such tests do not correlate satisfactorily with ad hoc tests duplicating manufacturing operations.

b. Engineering tests do not provide sufficient spread in results to distinguish between plastics of similar forming properties.

3. These tests have shown that several systems can be used to evaluate the two primary formability characteristics of plastic sheet. Any of the ad hoc tests, particularly the hemispherical draw and unconfined bubble tests, can be used to evaluate the modulus of workability. The deformative maximum is more difficult to gage; only the unconfined bubble test using a lubricated specimen was judged to measure impartially this property of the plastic.

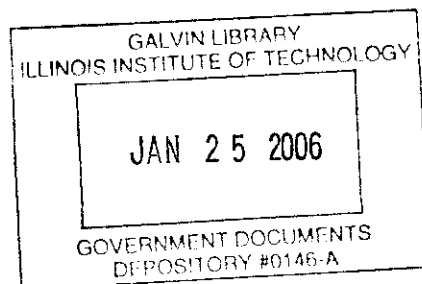

## PUBLICATION REVIEW

This report has been reviewed and is approved.

FOR THE COMMANDER

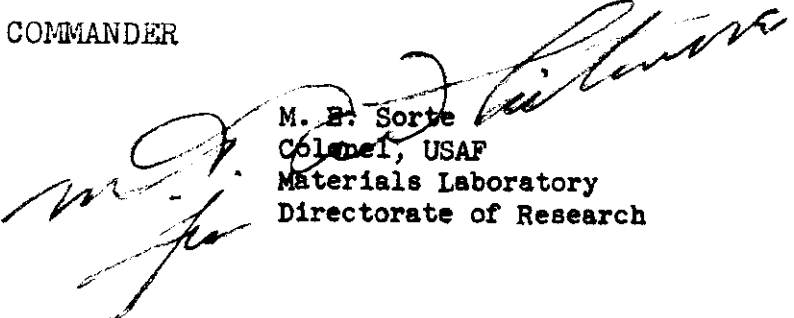
  
M. E. Sorte  
Colonel, USAF  
Materials Laboratory  
Directorate of Research

# Contrails

## TABLE OF CONTENTS

	<u>Page</u>
I. INTRODUCTION.....	1
II. OBJECTIVES OF THE CONTRACT.....	1
III. BASIC CONSIDERATIONS.....	2
IV. COMPILATION OF EXPERIMENTAL WORK ACCOMPLISHED.....	4
A. Conventional Engineering Tests.....	5
1. Tensile Stress-Strain Tests.....	5
2. Multiaxial Tension Tests.....	6
3. Creep Tests.....	6
4. Ball Penetration Tests.....	7
5. Poisson's Ratio Tests.....	7
B. <u>Ad Hoc</u> Tests.....	8
1. Hemispherical Forming.....	8
2. Positive Pressure Confined Bubble Test.....	9
3. Unconfined Blowing Test.....	10
4. Unconfined Blowing Test with Both Specimen and Orifice Lubricated.....	11
5. Draping Tests.....	11
6. Bending Test for Thermosetting Materials.....	12
V. DISCUSSION OF TEST RESULTS.....	12
A. Conventional Engineering Tests.....	12
1. Tensile Stress-Strain Tests.....	13
2. Biaxial Tension Tests.....	16

# Contrails

## TABLE OF CONTENTS (Cont.)

	<u>Page</u>
3. Creep Tests.....	17
4. Ball Penetration Tests.....	18
5. Poisson's Ratio Tests.....	19
B. <u>Ad Hoc</u> Tests.....	21
1. Hemispherical Vacuum Forming Test.....	22
2. Positive Pressure Confined Bubble Test.....	23
3. Unconfined Positive Pressure Bubble Test.....	24
4. Unconfined Positive Pressure Bubble Test with Lubricated Specimen and Orifice Plate.....	26
5. Draping Tests.....	27
6. Bending Test for Thermosetting Materials.....	27
VI. STATEMENT OF RECOMMENDED FORMABILITY RATING SYSTEM FOR TRANSPARENT PLASTICS.....	29
VII. CONCLUSIONS.....	30

# Contrails

## LIST OF ILLUSTRATIONS

<u>Fig.</u>		<u>Page</u>
1	MODULUS OF ELASTICITY VERSUS TEMPERATURE.....	48
2	CREEP TESTS CELLULOSE ACETATE AND ACRYLIC SHEET.....	49
3	VACUUM VERSUS FORMING OF BUBBLE DRAWN INTO 6-INCH HEMISPHERE.	50
4	PRESSURE-DEFORMATION CURVES FROM UNCONFINED BUBBLE TEST, 4-INCH DIAMETER BASE.....	51
5	PRESSURE-DEFORMATION CURVES FROM CONFINED BUBBLE TEST, 4-INCH DIAMETER BUBBLE IN 4-INCH TUBE.....	52
6	PRESSURE-DEFORMATION CURVES FROM UNCONFINED BUBBLE TEST, LUBRICATED SPECIMEN, 4-INCH DIAMETER AT BASE.....	53
7	GENERAL VIEW OF HEMISPHERE DRAWING APPARATUS.....	54
8	CONFINED BUBBLE TESTING APPARATUS.....	55
9	UNCONFINED BUBBLE TESTING APPARATUS.....	56
10	BEND TESTING APPARATUS FOR THERMOSETTING PLASTICS.....	57
11	TEMPERATURE-DEFORMATION CURVE FOR 1/16-INCH ACRYLIC SHEET AND 1/16-INCH CELLULOSE ACETATE.....	58
12	POISSON'S RATIO VERSUS DEFORMATION.....	59
13	EXAMPLE OF PHOTOGRAPHIC ENLARGEMENT USED IN DETERMINATION OF POISSON'S RATIO AT VARIOUS STRAINS.....	60
B-1	FORMING TEST APPARATUS FOR THERMOSETTING PLASTIC.....	B-2
B-2	FORMABILITY EVALUATION UNIT FOR THERMOPLASTIC MATERIAL.....	B-3

# Contrails

## LIST OF TABLES

<u>Table</u>		<u>Page</u>
I	VALUES OF MODULUS OF ELASTICITY AT VARIOUS TEMPERATURES .	32
II	CREEP TESTS . . . . .	33
III	BALL PENETRATION TESTS . . . . .	33
IV	VACUUM REQUIRED FOR 1- AND 2-INCH DEFORMATIONS IN HEMI- SPHERICAL VACUUM FORMING TEST . . . . .	34
V	SLOPE OF LOAD-DEFORMATION CURVES FROM HEMISPHERICAL VACUUM FORMING TEST . . . . .	35
VI	PRESSURE REQUIRED FOR 1- AND 2-INCH DEFORMATIONS IN CONFINED BUBBLE TEST . . . . .	36
VII	MAXIMUM DEFORMATIONS IN CONFINED BUBBLE TEST . . . . .	37
VIII	COMPARISON OF MAXIMUM PRESSURES IN CONFINED BUBBLE TEST .	38
IX	PRESSURE REQUIRED FOR 1- AND 2-INCH DEFORMATIONS IN UN- CONFINED BUBBLE TEST . . . . .	39
X	MAXIMUM DEFORMATIONS IN UNCONFINED BUBBLE TEST . . . . .	40
XI	COMPARISON OF DEFORMATIONS AT MAXIMUM PRESSURE IN UNCONFINED BUBBLE TEST . . . . .	41
XII	SLOPE OF LOAD-DEFORMATION CURVES IN UNCONFINED BUBBLE TEST	42
XIII	PRESSURE REQUIRED FOR 1- AND 2-INCH DEFORMATIONS IN UN- CONFINED BUBBLE TEST WITH LUBRICATED PLASTIC . . . . .	43
XIV	MAXIMUM DEFORMATIONS IN UNCONFINED BUBBLE TEST WITH LUBRICATED PLASTIC . . . . .	44
XV	SLOPE OF LOAD-DEFORMATION CURVES IN UNCONFINED BUBBLE TEST WITH LUBRICATED PLASTIC . . . . .	45
XVI	BEND TEST OF GLYCOL CARBONATE RESIN ALLYL BASE THERMOSETTING PLASTIC (221° F) . . . . .	46
XVII	VALUES OF POISSON'S RATIO FOR CELLULOSE ACETATE AND ACRYLIC SHEET AT VARIOUS DEFORMATIONS . . . . .	47



## DEVELOPMENT OF A PRACTICAL LABORATORY PROCEDURE TO BE USED IN EVALUATING THE FORMING QUALITIES OF PLASTIC SHEET MATERIALS

### I. INTRODUCTION

On 21 September 1951 the Wright Air Development Center and the Armour Research Foundation (ARF) entered into a contract (No. AF33(038)-27648), which provides for the research and development of forming tests for certain plastics. In accordance with the terms of this contract, the working period extends from the date of acceptance of the contract by the Foundation and by the Government until one year after this date. Since the final acceptance of the contract occurred on 16 January 1952 the work was performed between that date and 16 January 1953. This report is a summary of the work performed during that period.

The contract provides for the issuance of six bimonthly progress reports and for the delivery of a final report at the end of the contract period.

### II. OBJECTIVES OF THE CONTRACT

According to Part 1, Item 1, of the Statement of Work, on page 1a of the Contract, the objectives of the research and development work to be carried out by ARF may be stated as follows:

1. A study of the factors which are of importance in the formability of plastic materials.

2. Development of a laboratory test which will provide a ready means for rating the formability of certain specified plastics.

Two of these types were specified by the Sponsor (specifications: MIL-P-5425 Plastic, Sheet, Acrylic, Heat Resistant, Plexiglas II and specifications: A.F.-12040 Plastic Sheet, Transparent Allyl Base) and the third (specification: MIL-P-6887, Plastic Sheet, Cellulose-Acetate Base) was chosen by the

# Contracts

Foundation from two alternate materials. It is the understanding of the Foundation that the work contemplated under this contract extends only to the investigation of these three materials.

### III. BASIC CONSIDERATIONS

The first problem which arises in the consideration of the formability of plastics is agreement on a definition of formability acceptable to all parties. Formability, in common with characteristics affecting many processing operations, is a vague and indefinite term which lends itself to neither analytical interpretation nor to a well-defined experimental approach. Item 1e in the Contract (Statement of Work) mentions various properties of plastic materials which are considered indicative of formability, such as drape-forming, free-blowing, and drawing. Unfortunately, none of these properties is susceptible to attack by conventional engineering methodology, using, for example, the concept of a mechanical equation of state. If this were possible, one might assume that plastics, like all other materials, are subject to generalized isothermal stress-strain relations which may be expressed schematically in the following form:

$$\sigma_{x,y,z} = f \left[ \epsilon_{x,y,z}, \dot{\epsilon}_{x,y,z}, \frac{\partial \epsilon}{\partial s_{x,y,z}}, \nu, E, \phi, \int_0^t \epsilon(t) dt \right]$$

This equation relates the stress,  $\sigma_{x,y,z}$ , successively, to the strain, the strain rate, the geometrical strain gradient, the elastic constants  $\nu$  and  $E$ , the plastic modulus  $\phi$ , and the strain history. However, there appears to be no prospect of establishing such a mechanical equation of state for these plastics within the framework of the present contract. The difficulty of such a task may be illustrated by the fact that research extending over many

# Contrails

decades has, as yet, failed to produce a generally applicable equation of state for metals which have been under much more intensive investigation. For this reason a correlation of formability with quantities customarily obtained by engineering methods will have to proceed on a much more restricted basis. Therefore, ARF personnel believe that evaluating the formability characteristics of plastic sheet is a two-part process consisting of gaging, at optimum forming temperatures, (1) the extent to which the plastic can be deformed biaxially, and (2) the force required to deform the plastic. Of the two factors, the extent to which it can be stretched biaxially is judged the more important. It was the opinion of ARF, therefore, that the research carried out under this contract should proceed along the following lines of investigation:

1. Indication of formability by standardized engineering evaluation tests such as the tensile, creep, and ball penetration types.

2. Indication of formability by correlation of formability evidenced in performed ad hoc tests with engineering tests. In these ad hoc tests, industrial forming operations were duplicated in the laboratory as closely as time and expense permitted.

The latter type of testing served a dual function in this program. First, inasmuch as behavior of a plastic under these test conditions may, in itself, be considered a criterion of formability, such test can constitute, in effect, an acceptance test. Secondly, the latter type of test may be used as a yardstick to establish the adequacy of conventional engineering tests for measuring formability. If data which is ordinarily obtained on the mechanical properties of materials can be related to the formability of material as

# Contrails

measured by the ad hoc tests, it may be preferable to base a rating of materials on the conventionally obtained characteristics.

Prior to performance of experiments, it was not possible to predict whether correlation of conventional engineering and ad hoc tests would be possible. Therefore, ARF decided to proceed along both paths simultaneously to insure maximum likelihood of success in establishing a formability criterion.

Generally, these two types of tests were conducted by making simultaneous load-deformation measurements. Since only the cellulose acetate and acrylic sheet materials could be stretched, tests of this type were confined to these two materials. The third plastic, a thermosetting plastic which could not be stretched, was evaluated by a separate test described later in this report. In each test, several thicknesses of material were tested and the ratios of the test results of acrylic sheet and cellulose acetate were computed. The merit of the test was judged by (1) the relative rating of the plastics by the data, (2) the consistency of these ratios throughout the thickness range tested, and (3) the agreement of these ratios with test data ratios of the ad hoc group duplicating manufacturing forming operations.

It is believed that a statement of the pertinent work accomplished will aid in understanding the later discussions of test results and in the selection of formability criteria.

#### IV. COMPILATION OF EXPERIMENTAL WORK ACCOMPLISHED

Past experience in materials research has shown that the scatter present in experimental investigations of this kind makes it desirable to conduct multiple tests. In general, duplicate tests are adequate for exploratory purposes, although it may be advantageous or even necessary, under certain

# Contrails

conditions, to increase still further the number of tests performed under identical conditions. The various conditions under which tests have been conducted are given below.

## A. Conventional Engineering Tests

### 1. Tensile Stress-Strain Tests

Because ordinary tensile tests are so commonly performed, it appeared most desirable to base an interpretation of formability upon the results obtained from such tests. In this manner, information can be provided about (1) the properties of the material, (2) the variations of the properties to be expected within a given batch of the material, and (3) the importance of any anisotropy which may exist in the plastic. The following materials have been tested in various thicknesses and at various temperatures:

#### a. Cellulose Acetate

Thickness and Temperature: 1/16, 1/8, 1/4, 3/8, 1/2 inch at 70° F  
1/8 inch at 225° F  
1/16 inch at 150°, 200° F

Direction of Stressing: Lengthwise and crosswise to forming direction

#### b. Glycol Carbonate Resin Allyl Base

Thickness and Temperature: 1/16, 1/8 inch at 70° F  
1/8 inch at 150° and 200° F

Direction of Stressing: Lengthwise and crosswise to forming direction

#### c. Acrylic Sheet

Thickness and Temperature: 1/16, 1/8, 1/4, 3/8, 1/2 inch at 70° F  
1/16 inch at 150°, 200°, and 375° F  
1/8 inch at 300° F

Direction of Stressing: Lengthwise and crosswise to forming direction

## 2. Multiaxial Tension Tests

It is desirable to investigate the effect of multiaxial stress states upon the properties of the material. In any stretch-forming operation, the plastics will be exposed to at least biaxial stress conditions, with the third component of stress being very small. In a more intensive investigation than appeared possible under the present contract, one may, therefore, wish to explore more fully the behavior of the plastic materials under biaxial stress. A limited exploration of behavior under biaxial stress was accomplished as a by-product of the hemispheric forming test, which is one of the ad hoc tests discussed below. Inked grid lines on the sheet have shown that the strain distribution along a great circle in the drawn hemisphere is not uniform in the plane of the sheet, with very large strains occurring near the center of the dome (of the order of 100 per cent) as compared with its edge. Since the hemisphere, having a height-to-diameter ratio of 1:2, approaches the most severe stressing conditions which will be imposed in practice, one may surmise that a satisfactory evaluation test for formability should develop strains at least of the order of 100 per cent.

## 3. Creep Tests

This test involves measurements of deformation with respect to time at optimum forming temperatures of plastic materials at the constant tensile stress of 100 psi. The results indicate relative ease of uniaxial forming at constant stress.

### a. Cellulose Acetate

Thickness and Temperature: 1/16 inch at 275° F

# Contrails

b. Glycol Carbonate Resin Allyl Base

Thickness and Temperature: 1/16 inch at 320° F

c. Acrylic Sheet

Thickness and Temperature: 1/16 inch at 320° and 375° F

4. Ball Penetration Tests

This test consists of applying a 1/2-inch diameter ball, weighted with a load of 1-3/4 pounds to the surface of the heated plastic. Specimens in all cases were 2 inches square. Results are indicative of relative ease of forming. The following specific experiments have been conducted:

a. Cellulose Acetate

Thickness and Temperature: 1/2 inch at 275° F

b. Glycol Carbonate Resin Allyl Base

Thickness and Temperature: 1/2 inch at 320° F

c. Acrylic Sheet

Thickness and Temperature: 1/2 inch at 340° and 375° F

5. Poisson's Ratio Tests

Determinations of Poisson's ratio of cellulose acetate and acrylic sheet have been made at several degrees of strain, as it was thought there might be some relation between this ratio and formability performance. While this relationship might be impossible to determine in its final form by using only the materials specified in the contract, it was believed that the tests were necessary nevertheless. The need for additional research on this subject also might be indicated.

A 1/8-inch square grid was inked on reduced section tensile specimens prior to testing. These specimens were heated to optimum forming

temperature and loaded. Photographs were taken of the specimens at various degrees of deformation ranging from 0 to 105 per cent elongation; an enlargement of one of these photographs is shown in Fig. 13. Poisson's ratio was determined by comparative horizontal and vertical measurements of the grid on enlargements of the photographs. The following specific experiments have been conducted:

a. Cellulose Acetate

Thickness and temperature: 1/16 inch at 275° F

b. Glycol Carbonate Resin Allyl Base

Thickness and temperature: 1/16 inch at 375° F

B. Ad Hoc Tests

The ad hoc tests explored under this program were designed to resemble manufacturing operations as closely as possible and yet remain simple enough to permit their performance at low cost and in little time. These tests were wholly empirical in the sense that it was not attempted to make engineering measurements of stress and strain on the specimens. Five types of ad hoc tests have been carried out and descriptions follow:

1. Hemispherical Forming

This test involves the drawing of plastic sheet materials into a hemispherical mold 6 inches in diameter (see Fig. 7). Force is applied by evacuating the hemispherical cavity below the sheet, which is deformed at its optimum forming temperature. During the forming process the center deformation of the dome is measured as a function of the increasing vacuum.

It should be noted that it may not be necessary to take continuous measurements of this kind for the test to be acceptable as a classification



procedure. Classification could proceed either on the basis of attained deformation for a given vacuum or on the basis of applied vacuum at a given time for a given displacement. Since it is important that the time parameter for all tests be comparable, the time rate of stressing for all ad hoc tests was approximately the same. The following specific experiments have been performed:

a. Cellulose Acetate

Thickness: 1/16, 1/8, 1/4, 3/8, and 1/2 inch

Temperature: Forming (275° F)

b. Glycol Carbonate Resin Allyl Base

Thickness: 1/16 and 1/8 inch

Temperature: Approximately 300° F. No definite forming temperature has been established for this material.

c. Acrylic Sheet

Thickness and Temperature: 1/16 inch at 380° and 375° F

1/8, 1/4, and 3/8 inch at 375° F

1/2 inch at 340° and 375° F

2. Positive Pressure Confined Bubble Test

In this test, a 6-inch square specimen was heated within a tubular forming device, shown in Fig. 8, to the optimum forming temperature. The plastic specimen was formed inside the 4-inch diameter tube by positive air pressure. The height of the bubble was measured as a function of air pressure, the pressure application rate in each test being about the same. The confined blowing test could be adopted eventually as a means of maximum deformation classification without the necessity of taking continuous measurements during the forming process by measuring only the bubble height. The following specific experiments have been conducted:

# Contrails

## a. Cellulose Acetate

Thickness: 1/16, 1/8, 1/4, 3/8, and 1/2 inch

Temperature: Forming (275° F)

## b. Glycol Carbonate Resin Allyl Base

Thickness: 1/16, 1/8, and 1/4 inch

Temperature: Approximately 300° F

## c. Acrylic Sheet

Thickness and Temperature: 1/16 inch at 310° and 375° F

1/8 inch at 300° and 375° F

1/4 inch at 293° and 375° F

3/8 inch at 375° F

1/2 inch at 293° and 375° F

## 3. Unconfined Blowing Test

In this test a 6-inch square specimen was heated to optimum forming temperature while in contact with a 4-inch diameter orifice plate in the unit shown in Figs. 9 and B-2. This apparatus has been delivered as a part of the contract. The plastic specimen was formed by positive air pressure through the orifice in the shape of an unconfined sphere. The height of the bubble was measured as a function of air pressure, the pressure application rate in each test being the same. Here again, this test could be adopted as a means of maximum deformation classification, without the necessity of taking continuous measurements, by measuring only the bubble height. The following specific experiments have been conducted.

# Contrails

## a. Cellulose Acetate

Thickness: 1/16, 1/8, 1/4, 3/8, 1/2 inch

Temperature: Forming (275° F)

## b. Acrylic Sheet

Thickness: 1/16, 1/8, 1/4, 3/8, 1/2 inch

Temperature: 375° F

## 4. Unconfined Blowing Test with Both Specimen and Orifice Lubricated

This test was identical to that described above except that the specimen and orifice plate were lubricated with petroleum jelly. The procedure was identical to that described previously.

## 5. Draping Tests

This simple test involves the placing of a clamped strip of plastic heated to its optimum forming temperature over an opening in a metal plate. The total sag occurring under the weight of this plastic was then measured. It is assumed that formability may be expressed by the ratio of the sag to the length of the opening for any given material thickness.

The following specific experiments have been conducted on drape forming, all of them for a 6-inch opening:

### a. Cellulose Acetate

Thickness: 1/16, 1/8, 1/2 inch

Temperature: Forming (275° F)

### b. Glycol Carbonate Resin Allyl Base

Thickness: 1/16, 1/8 inch

Temperature: 320° F

## c. Acrylic Sheet

Thickness: 1/16, 1/8, 1/2 inch

Temperature: 320° F

## 6. Bending Test for Thermosetting Materials

Bending tests of a thermosetting or other plastic showing very poor forming qualities in the tests previously described will serve to differentiate further between materials incapable of being stretched biaxially. By bending strips of plastic around a male form the shape of a logarithmic spiral the radius of curvature at failure may be determined. This radius of curvature of the particular spiral chosen (see Appendix A) varies linearly along the curve, the variation being from a maximum radius of 12 inches to a minimum radius of 0.35 inch. The edge of the male form can be graduated, indicating radius of curvature at any point on the curve. The apparatus is shown in Figs. 10 and B-1. The following material has been tested in the indicated thicknesses and the apparatus has been delivered as part of the contract:

### Glycol Carbonate Resin Allyl Base

Thickness and Temperature: 1/8, 1/4, 3/8, 1/2 inch at 221° F

## V. DISCUSSION OF TEST RESULTS

### A. Conventional Engineering Tests

While a complete set of data has been obtained from tensile, creep, and ball penetration tests, these tests are not recommended for formability evaluation for the following reasons:

To be valid as a formability indicator, the engineering test data must correlate uniformly with those of the ad hoc group which duplicate manufacturing practice. This correlation, even though the plastics were rated in consistent

order by both test groups, is not strong enough to warrant adoption of the engineering test. Finally, the engineering tests did not provide sufficient spread in results to distinguish between plastics of similar forming properties. The lack of strong correlation emphasizes the importance of having the formability test duplicate manufacturing conditions.

## 1. Tensile Stress-Strain Tests

a. The elastic stiffness of the material, which is related to its initial modulus of elasticity,  $E_1$ , was considered at the inception of the project as a possible index of formability. If suitable, it would be an advantageous choice indeed since the value of  $E_1$  is readily obtainable from conventional tests, especially if they are conducted at room temperature. It is of interest, therefore, to review Table I and Fig. 1, which show the relation of  $E_1$  for the three materials at various temperatures. In perusing the data in this table, let it be noted that the determination of E at higher temperatures becomes increasingly difficult, so that the values given for 225° and 300° F must be considered with some caution.

Turning to the relative ratings of the materials, as expressed in the second and third portions of the table, the usefulness of  $E_1$  as a formability criterion appears rather dubious. According to the middle portion of the table, the rate of decrease of  $E_1$  of the allyl base material with increasing temperature approximates that of acrylic sheet. Since it is obvious that allyl base material, which is thermosetting, is far more brittle than acrylic sheet, the decrease of  $E_1$  with increasing temperature does not seem to provide a good means of classification. In this instance, this criterion did not differentiate properly between a brittle material, such as allyl base resin, and a relatively ductile material, such as acrylic sheet.

# Conclusions

One may wish to examine the data from a slightly different point of view, according to which the ratio of the values of  $E_1$  of different materials at temperatures which are identical and meaningful for all the materials involved, would be the criterion. The third part of Table I illustrates this aspect. If the value of  $E_1$  for cellulose acetate is taken as unity, then allyl base resin has values of  $E_1$  either very close to that of cellulose acetate or intermediate between it and that of acrylic sheet. In either case, the criterion is not acceptable since it does not distinguish a brittle material from a ductile one, and does not have the ability to grade thermoplastic and thermosetting materials properly. The conclusion, therefore, may be drawn that neither the value of  $E_1$  nor its dependence on temperature will serve as an acceptable criterion of formability.

b. A sufficient number of stress-strain tests has been performed on samples of different thicknesses of the same material to enable the statement to be made, with reasonable assurance, that the tensile properties of none of the three materials depend on the thickness of the sheet (which ranged from 1/16 to 1/2 inch). The available evidence does not encourage a belief that a systematic variation of strength properties with thickness exists. This is fortunate since it means that an engineering test, which can be correlated with formability, will not require specimens of a certain thickness, but rather that it will apply to all thicknesses, at least within the range investigated.

c. Despite the relative paucity of specimens for statistical purposes, sufficient evidence appears to have accumulated, as reported previously, to dismiss anisotropy as a factor in this investigation. This also is a

# Contrails

favorable finding since it eliminates concern about orientation effects and makes the use of unidirectional and nonsymmetrical tests possible.

d. The numerous stress-strain curves obtained with different thicknesses and at temperatures ranging from ambient to forming temperature can be utilized in other ways, of course, besides for obtaining values of the initial moduli of elasticity. One may desire, for example, to consider as a formability criterion some function of total extension of a standardized test specimen at fracture at any given temperature, such as, the modulus of resilience, or modulus of toughness. It is now apparent that the tension test must be conducted at optimum forming temperatures if forming properties at these same optimum forming temperatures are to be evaluated.

Tension tests have been conducted on both acrylic sheet and on cellulose acetate by keeping the tensile load constant and raising the temperature gradually to the forming range. The rate of temperature rise was the same in each test. Measurements of extension were taken at intervals of temperature rise throughout the test.

An examination of these temperature-deformation curves (Fig. 11) shows, by the change of slope, that extension rates for the two materials are very different from each other near the optimum forming temperature. Thus, it can be concluded that tests conducted at an arbitrarily selected number of degrees below optimum forming temperature would give an erroneous indication of formability. On the other hand, if the tensile test is conducted at optimum forming temperature, the modulus of elasticity is low enough to be considered insignificant. The load required to cause rupture cannot be measured with an

# Contrails

ordinary testing machine. Modulus of elasticity, resilience, and toughness are zero under these conditions.

Total extension at rupture might be used as a formability criterion. However, this evaluates maximum possible deformation and has the same deficiencies as mentioned at the beginning of Part V-A (discussion of engineering test results).

## 2. Biaxial Tension Tests

Attempts have been made to study the permanent deformations over the face of a hemispherically drawn plastic configuration. A 1/2-by-1/2-inch grid, as well as concentric circles located 1/4 inch apart, were ruled on plastic sheet. After drawing, the distortion was measured and plotted, as reported previously. It can be seen that maximum distortion is of the order of 100 per cent. Also, it can be noted that residual stress can be computed in such a specimen by sawing out an area at which stress is desired and noting the change of curvature.

If it had been considered advisable to take the fullest possible advantage of the hemispherical forming tests, complete strain measurements on the dome could have been taken to show the influence of multiaxiality on the deformations as an indication of the properties of the material. Such measurements, aside from going beyond the engineering scope of this work, would have required far more elaborate instrumentation at greater expense of time and money. For these reasons, the forming tests have been looked upon as wholly empirical experimentation.

It is worth noting that, if the proper measurements had been taken, octahedral shear stress-strain curves could have been plotted to



illustrate the effect of complex stress states. In this manner some information on the plastic behavior of plastics analogous to that recently developed on the plastic behavior of metals could have been obtained. It may ultimately become very desirable to carry out such work, especially if plastics should be used under increasingly complex loading conditions, rather than in sheet form or as membranes, as appears to be the current practice.

### 3. Creep Tests

Test results are shown in Table II and Fig. 2. Since the tension tests pointed out that a systematic variation of strength properties with thickness does not exist, only the 1/16-inch material was included in the creep tests.

The ratio of unit deformation for various time intervals of the two materials is almost constant. It is seen that the cellulose acetate at 275° F elongated 3 to 3-1/2 times as much as the acrylic sheet at 375° F under the same stress for the same time duration. Only the extension ratio at the 20-minute time duration lies outside the 3.0 to 3.5 ratio values. Previously reported creep tests carried out at 275° F for the cellulose acetate and 340° F for the acrylic sheet showed this ratio to be 8 to 1. However, it has been concluded in the tension test discussion that all test temperatures for each plastic evaluated should be the same. Some manufacturers' literature recommends optimum forming temperatures dependent upon the sheet thickness. This is to compensate for the higher heat loss in the thinner sizes. This loss, however, did not occur in the heated testing jigs used by the Foundation.

The diallyl glycol carbonate resin allyl base elongated only 0.06 inch the first 15 seconds of the test and then showed no more extension.

# Contrails

This test would constitute a fair index if ease of uniaxial deformation alone were taken as the definition of formability, since the test essentially measures how much forming can be accomplished by equal loads on two specimens.

Since ease of uniaxial forming only is indicated, and the test, as an engineering test, has the same disadvantage as that discussed in the beginning of this section, this procedure has not been recommended as part of a formability criterion.

#### 4. Ball Penetration Tests

Test results are shown in Table III. Tests were run and reported previously on cellulose acetate at 275° F and on acrylic sheet at 340° F. The acrylic sheet tests were re-run at 375° F for the reasons given in the discussion of the creep test. Ratios of results for cellulose acetate and acrylic sheet for the various time intervals reported in the table average 4.1:1. Tests of the allyl base material were made but ball penetration amounted to only a few thousandths of an inch during 30 seconds. No further penetration occurred.

While both creep and ball penetration tests can be considered to be examples of plastic flow, the tensile creep test represents one-dimensional stressing, while that of the ball penetration test represents three-dimensional stressing.

Again, this test might evaluate formability ease alone for three-dimensional flow. However, the results obtained would be only generally indicative of the plastic material tested. To be specifically indicative of ease of forming of each individual thickness of plastic sheet, the ball penetration test would have to be first correlated with the actual force required

to biaxially stretch plastic of each thickness tested. Because this procedure would be too time-consuming, the test is not recommended for formability evaluation.

It is noted that the average ratio of test results of the two materials (4.1:1) agrees closely with the average ratio (4.4:1) of the load deformation curve slopes of the unconfined bubble test with lubricated specimen. (See Table XV.)

## 5. Poisson's Ratio Tests

This separate observation, in connection with the tensile studies of plastic sheet, was made to better understand the stretching performance of the materials. In developing a formability criterion, it is desirable to investigate all possible phases of behavior under stress. Differences in Poisson's ratio might indicate a possible formability criterion, although such a criterion probably could not be established on the basis of test data from only two plastic materials.

The test results are shown in Table XVII and in Fig. 12. As would be expected from rubber-like materials, Poisson's ratio decreases, in both cases, as the longitudinal deformation increases. Also, Poisson's ratio for cellulose acetate is about one-tenth higher than for acrylic sheet at the deformation occurring at the apex of a hemisphere.<sup>1</sup> These values are confirmed by considering the expression for strain,

$$\epsilon_x = \frac{1}{E} \left[ \sigma_x - \nu(\sigma_y + \sigma_z) \right],$$

---

<sup>1</sup>See Fig. 7, Report No. 5, for strain values occurring in a drawn hemisphere.

# Contrails

where  $\epsilon_x$  is the strain along the x axis, E is the modulus of elasticity,  $\nu$  is Poisson's ratio, and  $\sigma_x$ ,  $\sigma_y$ , and  $\sigma_z$  are stresses parallel to the x, y, and z axes, respectively.

Considering hemispheres drawn from 1/4-inch sheets of the two materials, direct measurements show the strain at the apex of the cellulose acetate hemisphere to be 1.2 times that of the strain of the acrylic sheet hemisphere. The vacuum required in the case of acrylic sheet is 2.1 times that required in the case of cellulose acetate. The apex thickness was 0.085 inch in the case of cellulose acetate and 0.075 inch in the case of acrylic sheet.

The ratio of the modulus of elasticity, E, of acrylic sheet to that of cellulose acetate is 2.5 as determined by tangents drawn to the slope of creep curves shown in Fig. 2. These tangents were drawn to the curves at an ordinate of 0.5 minute, which was the time required to form the subject hemisphere.

Examining the expression

$$\frac{\epsilon_{x_c}}{\epsilon_{x_a}} = \frac{E_a}{E_c} \frac{\sigma_{x_c}(1-\nu_c)}{\sigma_{x_a}(1-\nu_a)}$$

where c denotes cellulose acetate and a denotes acrylic sheet, we find that  $\sigma_x$  equals  $\sigma_y$  at the apex of a hemisphere and that  $\sigma_z$  is negligible.

Substituting actual measured values in the above equation,

$$\begin{aligned} \frac{\epsilon_{x_c}}{\epsilon_{x_a}} &= 2.5 \frac{1}{2.1 \times \frac{0.085}{0.075}} \left( \frac{1-\nu_c}{1-\nu_a} \right) \\ &= 1.05 \left( \frac{1-0.16}{1-0.28} \right) \\ &= 1.2 . \end{aligned}$$

# Contrails

This confirms our experimentally derived values of Poisson's ratio.

There seems to be no unusual behavior or indicated need for further investigation in this line. We have concluded that other, more direct, formability tests are easier to conduct and interpret.

## B. Ad Hoc Tests

It will be noted from earlier statements that an essentially complete set of experimental data from the ad hoc tests, in the form of force-deformation curves, has been obtained for all three materials and for most thicknesses of interest. Before commenting on specific results, it is appropriate to devote a few remarks to general requirements of ad hoc tests. A test of this kind should (1) embody straining at least of the order to be expected in manufacturing operations, (2) create stress states of magnitude and direction similar to those encountered in practice, (3) be conducted at recommended optimum forming temperatures, and (4) maintain the physical state of the material comparable with that extant in manufacturing practice. In addition, of course, the usual desiderata of reproducibility of results at low expense of time and money apply here. It is believed that the types of ad hoc tests carried out on this program comply with these requirements reasonably well.

All five ad hoc tests clearly differentiate the allyl base resin from the thermoplastic materials. In fact, the deformations attainable in either drawing or blowing tests of the thermosetting material do not exceed 1/8 inch for any thickness at which deflection a brittle failure occurs. For this reason, the results of the tests of allyl base resin are not even reported in the tables. Any of the ad hoc tests are preferable to any of the

engineering tests including E values from tensile tests, therefore, in their ability to separate thermoplastic and thermosetting compounds.

## 1. Hemispherical Vacuum Forming Test

This test, using a forming temperature of 275° F for the cellulose acetate and various temperatures, recommended by the manufacturer, for the acrylic sheet, was made and reported previously. Additional tests discussed herein were conducted, forming the acrylic sheet at the constant temperature of 375° F for the reasons discussed previously.

In the case of both cellulose acetate and acrylic sheet, the vacuum required to form the material (see Table IV) is nearly constant, regardless of the thickness of the specimen. This is not the behavior to be expected from materials in general, as ordinarily increasing thickness requires increasing vacuum to attain a given deformation.

The slope of the load-deformation curves recorded in Table V and shown in Fig. 3 is an indication of ease of forming, and the ratios of test results of the two materials are quite consistent. This test does have the following advantages over other ad hoc tests: The specimen can be frozen or allowed to cool so the deformed specimen can be examined later for cracking, crazing, etc., which may develop during or subsequent to forming. Flow of material throughout the sheet is more uniform since less frictional resistance is developed on the material near the clamped edge, and control of a fixed end point is more precise (especially important if "springback" or subsequent creep is to be studied).

Disadvantages of the test are that it cannot be carried to rupture of the specimen and, therefore, cannot evaluate maximum deformation. While

the test evaluates ease of forming well, it is not recommended because a test evaluating this quality can be applied more efficiently at the same time that one is evaluating the maximum biaxial deformation. This will avoid using another piece of apparatus in the determination of the formability rating.

## 2. Positive Pressure Confined Bubble Test

Both acrylic sheet and cellulose acetate generally require increasing pressure with increasing thickness in this particular test for maximum deformation. This appears to be a normal behavior to be expected from materials in general. The rate of increase, as shown in Fig. 5, is higher for the acrylic sheet than for the cellulose acetate. However, it is interesting to note that this difference in required pressure does not occur, in the case of acrylic sheet, at the lower deformation values. For deformations up to 1-1/4 inch the load-deformation curves are almost identical. Thus, a regular band of load-deformation curves is obtained for three of four thicknesses of acrylic sheet tested. Cellulose acetate shows the same property but to a lesser extent.

Table VI shows the ratio of the pressures required to obtain both 1- and 2-inch deformations for equal thicknesses of the two materials. These ratios are not consistent and are, therefore, not recommended as formability criteria.

Data ratios on the maximum deformations at rupture shown in Table VII, which form a criterion of maximum possible biaxial deformation, are fairly consistent. Studies of maximum pressure were made and are shown in Table VIII, but the consistency of data ratios is not good. This test has the advantage of showing both ease of forming and maximum possible biaxial deformation in one test.

# Contrails

It is believed, however, that the disadvantages of the test outweigh the advantages. The results are influenced by the friction of the heated plastic along the tube as the bubble is formed, and is, therefore, dependent upon the inside finish of the apparatus and the "stickiness" of the plastic in the heated state. In fact, this friction was of such magnitude as to cause tears in the cellulose acetate as evidenced by examination of formed specimens. The height of the bubble obtainable at rupture is also affected by this friction, particularly if the bubble walls along the cylindrical portions of the apparatus are thick. The thicker plastic, requiring higher deforming pressures, is restrained more firmly against motion along the wall by friction than thinner material; therefore, a proportionately smaller amount of material is available at the hemispherical end.

This test is not recommended for formability studies because of the disadvantages mentioned above.

### 3. Unconfined Positive Pressure Bubble Test

This test was designed to correct the disadvantages of the confined bubble test discussed above. It was observed (see Fig. 4) in the case of the acrylic sheet, that deformation increased with increasing pressure until a maximum pressure was reached. At that time, the bubble expanded without further increases in pressure. In fact, the pressure fell off with no apparent decrease in bubble expansion rate. The process could have been stopped, however, at any point by releasing air.

Generally, the same observations regarding the load-deformation curves can be made as for the confined bubble test. Test results are shown in



# Contrails

Tables IX to XII. The comparison giving the greatest consistency in ratios of test data, acrylic sheet to cellulose acetate, is the bubble height at maximum pressure. An explanation of why the data taken at maximum pressure rather than at maximum bubble height gives more consistent ratios might be found in an examination of the load-deformation curve. The acrylic sheet seems to have a second "yield point" (even though the material is plastic) with great extension at reduced load beyond this point. The cellulose acetate does not show this characteristic; the load-deformation curve rises to rupture without any "flattening out" of the curve. Since the stretch or deformations of cellulose acetate is less than for acrylic sheet, the thickness of acrylic sheet is less at rupture. Thus, small surface irregularities would affect the acrylic sheet results more than the cellulose acetate results. By computing ratios of data taken before rupture the effect of surface irregularities is partially avoided.

Differences in ease of formability within the same class of material are shown by comparing the load-deformation curves of cellulose acetate (Fig. 4). The curves for 1/8- and 1/4-inch thicknesses group themselves separately from the curves for 1/16-, 3/8-, and 1/2-inch thicknesses which were received in a different shipment.

Advantages of this test are that the specimen material is completely unrestrained and that there is no external friction on the bubble proper to cause premature fracture. Both ease of forming and maximum possible stretching are measurable in the same test at the same time.

# Contrails

Disadvantages are that friction of the orifice ring on the plastic still causes some premature failures. For this reason the test is not recommended for formability evaluation.

#### 4. Unconfined Positive Pressure Bubble Test with Lubricated Specimen and Orifice Plate

This test was designed to correct the disadvantage of the similar test described above. Since the added lubrication changed the test conditions, a complete new set of tests was conducted. This test is the one finally recommended for formability evaluation. While the consistency of data ratios, acrylic sheet to cellulose acetate, is not as uniform as in some of the other tests, the staff members engaged in this work believe that it evaluates the plastic material in the best possible way. Evaluation is made by a process almost identical to manufacturing operation.

In choosing the slope of the load-deformation curve as indicative of ease of forming, the Foundation realizes the slope may, in some cases, be difficult to determine. However, the load-deformation curves of all tests fell, generally, into two groups of different slope, one group for acrylic sheet and one group for cellulose acetate. These slopes were fairly well pronounced.

There is no question of interpretation in regard to the maximum height of bubble obtainable. The value is read directly on a scale.

Test results are recorded in Tables XIII, XIV, and XV and are plotted in Fig. 6. In examining the slope of the load-deformation curves, it is apparent that thickness of specimen affects the slope more in the case of cellulose acetate than in the case of acrylic sheet. For this reason, ratios

# Contrails

of test results, acrylic sheet to cellulose acetate, vary widely from a constant value. The 1/16-inch acrylic sheet load-deformation curve, as in the hemispheric vacuum, confined bubble, and unlubricated unconfined bubble tests, fell outside the group of curves for other thicknesses of the same material. This appears to be a characteristic of the thinner sheets of this material possibly from a slightly different composition of the acrylic sheet.

Forming qualities of individual sheets vary to such an extent that reporting of test results closer than the nearest 1/2-inch deformation is probably not warranted. Probable error computation based on the mean deviation and the number of tests run confirm this belief.

In examining height of bubble data, it can be said that in this test acrylic sheet will form a spherical bubble 5-1/2 inches high, while cellulose acetate will produce a bubble 3 inches high.

## 5. Draping Tests

This test was recognized as a variation of the creep test, the constant stress of the creep test being replaced by the dead-weight stress. Since the comments applied to the creep test apply here, no further comments are necessary.

## 6. Bending Test for Thermosetting Materials

The test results, showing the minimum radius to which this material can be formed about the particular logarithmic spiral chosen, are given in Table XVI.

An examination of this table shows that the scatter of results in tests of 1/8- and 1/4-inch thick specimens is very large compared to the scatter of 3/8- and 1/2-inch specimens. The 1/8- and 1/4-inch material was cut from 20-inch-by-40-inch sheets which had been on hand for several months,

# Contrails

The 3/8- and 1/2-inch material was ordered from the manufacturer in the form of 3-inch-by-12-inch bars, the edges of which were found to be very smooth, completely free from nicks and notches. While great care was used by ARF personnel in cutting the 1/8- and 1/4-inch material from the large sheets, we feel that handling the material during the cutting process may have introduced small scratches and stress raisers. The scatter could have resulted from either edge irregularities or from a change in properties caused by aging.

The test specimens were heated to forming temperature in a furnace and the test jig was heated by electric coils located on the underside of the forming jig surface. However, the top surface of the plastic was exposed to the atmosphere, and while heat losses were held to a minimum, the thinner materials would be expected to sustain the greater heat losses. This fact may also explain the scatter of test results in cases of thinner materials.

The averages of test results show remarkable consistency when compared on the basis of thickness. The minimum radius at fracture, assuming that the material was uniform throughout, should be directly proportional to the thickness. Bend test ratios of 1/8-, 1/4-, 3/8, and 1/2-inch thick specimens should be theoretically in the ratio of 1:2:3:4. Table XVI shows how closely this ratio approximates the expected behavior for 1/8-, 1/4-, and 3/8-inch sizes. The 1/2-inch thick specimen test ratio, however, deviates from the theoretical by 22 per cent. Before bending, a 1/8-inch grid was ruled on both surfaces of the specimens. Distortion measurements after forming showed shortening on the compression side of the sheet, but no elongation on the tension side. This confirms the results of other tests showing that the material cannot be stretched appreciably.

## VI. STATEMENT OF RECOMMENDED FORMABILITY RATING SYSTEM FOR TRANSPARENT PLASTICS

It is believed that evaluating the formability characteristics of plastic sheet is a two-part process consisting of gaging (1) the extent to which the plastic can be deformed biaxially at optimum forming temperatures, and (2) the force required to deform the plastic. The extent to which it can be stretched biaxially is judged to be the more important of the two factors.

The formability system recommended consists of plotting, as an abscissa on cross-section paper, the maximum height at rupture of a free-blown plastic bubble blown through a 4-inch orifice, the plastic being lubricated with petroleum jelly and at optimum forming temperature. The modulus of workability, defined as the cotangent of the load-deflection curve from this free-blow test, is plotted as an ordinate. The formability index, then, is the numerical value of the two coordinates, the ordinate value being prefixed by a "W" and the abscissa value by "H".

A high abscissa value would indicate ability of the plastic to be biaxially stretched large amounts. A high ordinate value would indicate that the slope of the load-deflection curve was low, thus, the plastic would require a small amount of force for biaxial forming.

Two different plastics could not receive similar formability ratings unless their forming characteristics were almost identical. As an example, 1/16-inch cellulose acetate sheet is rated H 2.75, W 0.50, while 1/16-inch acrylic sheet is rated H 6.30, W 0.20.

Thermosetting plastics and other materials showing exceptionally poor biaxial forming characteristics shall be tested further by bending alone. In

these cases, the minimum radius of curvature causing fracture, prefixed by "R", of a 1-inch wide strip of the material shall be added to the index found, as described above.

## VII. CONCLUSIONS

1. A suitable formability criterion for transparent plastic sheet must embody evaluation of (a) ease of forming, and (b) maximum extent of forming possible.

2. Standardized engineering tests performed at optimum forming temperature and providing such data as maximum elongation, creep, and ball penetration values fail to evaluate satisfactorily formability for the following reasons:

a. Data from such tests do not correlate satisfactorily with ad hoc tests which duplicate manufacturing operations.

b. Engineering tests do not provide sufficient spread in results to distinguish between plastics of similar forming properties.

3. This program has shown that several systems can be used to evaluate the two primary formability characteristics of plastic sheet. Any of the ad hoc tests, particularly the hemispherical draw and unconfined bubble tests can be used to evaluate the modulus of workability. The deformative maximum is more difficult to gage. The unconfined bubble test, using a lubricated specimen, was judged to provide the best measure of this plastic property, and it is the test recommended for rating purposes. The results obtained from this test are expressed in a dual number representing both ease of forming and absolute deformability.

4. It will be noted that the foregoing conclusions do not relate to time-dependent properties of plastic but only to those which appear significant

# *Contrails*

during the initial forming period of fresh material. Possible time-dependent behavior of plastics evidenced by phenomena such as crazing, distortion, cracking, and opaqueness is not evaluated by the tests described herein.

# *Contrails*

Table I VALUES OF MODULUS OF ELASTICITY AT VARIOUS TEMPERATURES

Temperature, °F	Modulus of Elasticity, psi		
	Cellulose Acetate	Allyl Base	Acrylic Sheet
70*	229,850	222,525	401,125
150	50,200	76,470	205,770
200	17,350	48,360	76,470
225	465		
300			335
<u>Ratios (Assuming that at 70° F, E = 1.00)</u>			
70	1.00	1.00	1.00
150	0.22	0.343	0.512
200	0.075	0.217	0.191
300			0
<u>Ratios (Assuming Cellulose Acetate = 1.00)</u>			
70	1.00	0.97	1.75
150	1.00	1.52	4.10
200	1.00	2.87	4.40

\*Based on average values for 1/16-inch material.



# Contrails

Table II CREEP TESTS

(3-lb Weight on 1/16 by 1/2 in. Tensile Specimens)

Time, min.	Total Unit Creep, in/in.			
	1	5	10	20
Cellulose Acetate (275° F)	0.94	1.14	1.23	1.28
Acrylic Sheet (375° F)	0.26	0.34	0.41	0.53
Ratio $\frac{\text{Cellulose Acetate}}{\text{Acrylic Sheet}}$	3.6	3.4	3.0	2.4

Table III BALL PENETRATION TESTS

(1/2-in. Diameter Ball Weighted  
with 1-3/4 lb Penetrating 1/2-in. Thick Material)

Time, min.	Total Ball Penetration, in.			
	1	5	10	20
Cellulose Acetate (275° F)	0.154	0.198	0.217	0.248
Acrylic Sheet (375° F)	0.042	0.046	0.050	0.061
Ratio $\frac{\text{Cellulose Acetate}}{\text{Acrylic Sheet}}$	3.7	4.3	4.3	4.1

# Contrails

Table IV VACUUM REQUIRED FOR 1- AND 2-INCH DEFORMATIONS IN  
HEMISPHERICAL VACUUM FORMING TEST

Material	Thickness, .in.	Vacuum Required, in. Hg,	
		for 1-in. Deformation	for 2-in. Deformation
Acrylic Sheet (375° F)	1/16	2.8	6.4
	1/4	4.6	8.9
	3/8	4.0	9.7
	1/2	4.2	9.2
Cellulose Acetate (275° F)	1/16	1.5	3.7
	1/4	1.5	3.4
	3/8	1.7	4.4
	1/2	1.7	4.4
Ratio $\frac{\text{Acrylic Sheet}}{\text{Cellulose Acetate}}$	1/16	1.9	1.7
	1/4	3.1	2.6
	3/8	2.3	2.2
	1/2	2.5	2.1

# Contrails

**Table V SLOPE OF LOAD-DEFORMATION CURVES FROM  
HEMISPHERICAL VACUUM FORMING TEST**

Material	Thickness, in.	Slope, in. Hg/in. defl.
Acrylic Sheet (375° F)	1/16	4.2
	1/4	5.1
	3/8	5.3
	1/2	5.6
Cellulose Acetate (275° F)	1/16	1.7
	1/4	1.7
	3/8	2.4
	1/2	2.4
Ratio $\frac{\text{Acrylic Sheet}}{\text{Cellulose Acetate}}$	1/16	2.5
	1/4	3.0
	3/8	2.2
	1/2	2.3

# *Contrails*

Table VI PRESSURE REQUIRED FOR 1- AND 2-INCH DEFORMATIONS IN  
 CONFINED BUBBLE TEST

Material	Thickness, in.	Pressure Required, in. Hg,	
		for 1-in. Deformation	for 2-in. Deformation
Acrylic Sheet (375° F)	1/16	6.3	9.3
	1/8	12.8	18.6
	1/4	14.6	26.1
	3/8	12.3	32.4
	1/2	17.6	43.3
Cellulose Acetate (275° F)	1/16	3.2	8.6
	1/8	3.0	7.6
	1/4	3.2	4.9
	3/8	6.0	11.3
	1/2	7.2	13.5
Ratio $\frac{\text{Acrylic Sheet}}{\text{Cellulose Acetate}}$	1/16	2.0	1.1
	1/8	4.3	2.4
	1/4	4.6	5.3
	3/8	2.0	2.9
	1/2	2.4	3.2

Table VII MAXIMUM DEFORMATIONS IN  
CONFINED BUBBLE TEST

Material	Thickness, in.	Maximum Deformation (Avg. of Tests), in.
Acrylic Sheet (375° F)	1/16	5.05
	1/8	5.23
	1/4	4.48
	3/8	4.51
	1/2	5.57
Cellulose Acetate (275° F)	1/16	2.29
	1/8	3.10
	1/4	3.35
	3/8	3.37
	1/2	3.17
Ratio $\frac{\text{Acrylic Sheet}}{\text{Cellulose Acetate}}$	1/16	2.2
	1/8	1.7
	1/4	1.3
	3/8	1.3
	1/2	1.8

Table VIII COMPARISON OF MAXIMUM PRESSURES IN  
CONFINED BUBBLE TEST

Material	Thickness, in.	Maximum Pressure, in. Hg
Acrylic Sheet (375° F)	1/16	9.5
	1/8	18.8
	1/4	27.6
	3/8	37.7
	1/2	49.4
Cellulose Acetate (275° F)	1/16	10.0
	1/8	17.5
	1/4	9.6
	3/8	22.4
	1/2	24.2
Ratio $\frac{\text{Acrylic Sheet}}{\text{Cellulose Acetate}}$	1/16	0.9
	1/8	1.1
	1/4	2.9
	3/8	1.7
	1/2	2.0

# Contrails

**Table IX PRESSURE REQUIRED FOR 1- AND 2-INCH DEFORMATIONS IN  
UNCONFINED BUBBLE TEST**

Material	Thickness, in.	Pressure Required, in. Hg,		Maximum Pressure, in. Hg
		for 1-in. Deformation	for 2-in. Deformation	
Acrylic Sheet (375° F)	1/16	5.3	7.6	7.6
	1/8	12.4	18.5	18.5
	1/4	12.7	24.4	24.7
	3/8	11.3	27.3	29.5
Cellulose Acetate (275° F)	1/16	3.5	12.1	13.1
	1/8	2.8	6.0	10.2
	1/4	3.5	5.5	8.2
	3/8	5.0	9.8	15.4
Ratio $\frac{\text{Acrylic Sheet}}{\text{Cellulose Acetate}}$	1/16	1.5	0.6	0.6
	1/8	4.4	3.1	1.8
	1/4	3.6	4.4	3.0
	3/8	2.3	2.8	1.9

Table X MAXIMUM DEFORMATIONS IN  
UNCONFINED BUBBLE TEST

Material	Thickness, in.	Maximum Deformation, in.
Acrylic Sheet (375° F)	1/16	6.85
	1/8	5.85
	1/4	3.97
	3/8	5.37
Cellulose Acetate (275° F)	1/16	2.15
	1/8	2.76
	1/4	3.17
	3/8	3.05
Ratio $\frac{\text{Acrylic Sheet}}{\text{Cellulose Acetate}}$	1/16	3.2
	1/8	2.1
	1/4	1.3
	3/8	1.8



# Contrails

Table XI COMPARISON OF DEFORMATIONS AT MAXIMUM PRESSURE IN  
UNCONFINED BUBBLE TEST

Material	Thickness, in.	Deformation at Maximum Pressure, in.
Acrylic Sheet (375° F)	1/16	1.65
	1/8	1.85
	1/4	1.95
	3/8	2.45
Cellulose Acetate (275° F)	1/16	2.15
	1/8	2.76
	1/4	3.17
	3/8	3.05
Ratio $\frac{\text{Acrylic Sheet}}{\text{Cellulose Acetate}}$	1/16	0.8
	1/8	0.7
	1/4	0.6
	3/8	0.8

# Contrails

**Table XII SLOPE OF LOAD-DEFORMATION CURVES IN  
UNCONFINED BUBBLE TEST**

Material	Thickness, in.	Slope, in. Hg/in. defl.
Acrylic Sheet (375° F)	1/16	7.5
	1/8	16.2
	1/4	15.0
	3/8	17.7
Cellulose Acetate (275° F)	1/16	8.4
	1/8	3.3
	1/4	3.5
	3/8	4.9
Ratio $\frac{\text{Acrylic Sheet}}{\text{Cellulose Acetate}}$	1/16	0.9
	1/8	4.9
	1/4	4.3
	3/8	3.6

**Table XIII PRESSURE REQUIRED FOR 1- AND 2-INCH DEFORMATIONS IN  
UNCONFINED BUBBLE TEST WITH LUBRICATED PLASTIC**

Material	Thickness, in.	Pressure Required, in. Hg,	
		for 1-in. Deformation,	for 2-in. Deformation
Acrylic Sheet (375° F)	1/16	4.2	5.9
	1/8	10.4	17.0
	1/4	13.3	25.0
	3/8	13.3	30.0
	1/2	18.0	33.4
Cellulose Acetate (275° F)	1/16	1.9	4.0
	1/8	2.6	5.2
	1/4	3.6	5.9
	3/8	6.3	11.3
	1/2	7.3	15.6
Ratio $\frac{\text{Acrylic Sheet}}{\text{Cellulose Acetate}}$	1/16	2.2	1.4
	1/8	4.0	3.3
	1/4	3.7	4.2
	3/8	2.1	2.7
	1/2	2.5	2.1

# Contrails

Table XIV MAXIMUM DEFORMATIONS IN  
UNCONFINED BUBBLE TEST WITH LUBRICATED PLASTIC

Material	Thickness, in.	Maximum Deformation, in.
Acrylic Sheet (375° F)	1/16	6.30 ± 0.5*
	1/8	6.56 ± 0.1
	1/4	5.18 ± 0.1
	3/8	4.68 ± 0.2
	1/2	5.28 ± 0.5
Cellulose Acetate (275° F)	1/16	2.75 ± 0.2
	1/8	2.80 ± 0.0
	1/4	2.80 ± 0.2
	3/8	2.97 ± 0.1
	1/2	2.60 (Shear Failure)
Ratio $\frac{\text{Acrylic Sheet}}{\text{Cellulose Acetate}}$	1/16	2.3
	1/8	2.3
	1/4	1.9
	3/8	1.6
	1/2	---

\* Probable error shown.

# Contrails

**Table XV SLOPE OF LOAD-DEFORMATION CURVES IN  
UNCONFINED BUBBLE TEST WITH LUBRICATED PLASTIC**

Material	Thickness, in.	Slope, in. Hg/in. defl.
Acrylic Sheet (375° F)	1/16	5.1
	1/8	15.0
	1/4	18.9
	3/8	16.0
	1/2	17.9
Cellulose Acetate (275° F)	1/16	2.0
	1/8	2.6
	1/4	3.0
	3/8	5.9
	1/2	6.7
Ratio $\frac{\text{Acrylic Sheet}}{\text{Cellulose Acetate}}$	1/16	2.5
	1/8	5.8
	1/4	6.3
	3/8	2.7
	1/2	2.7

Table XVI BEND TEST OF GLYCOL CARBONATE RESIN

ALLYL BASE THERMOSETTING PLASTIC (221° F)

Thickness of* Material in.	Radius of Curvature of Fracture, in.						Ratio of Average of Test Results (1/8" Avg. = 1.0)	
	<u>Test No.</u>						<u>Average</u>	
	<u>1</u>	<u>2</u>	<u>3</u>	<u>4</u>	<u>5</u>	<u>6</u>		
1/8	1.9	2.9	5.0	2.4	2.2	1.4	2.6	1.0
1/4	2.0	6.0	4.3	7.0	7.5	4.6	5.2	2.0
3/8	7.6	7.5	7.8	8.1			7.7	3.0
1/2	8.2	8.1	8.4				8.2	3.1

\* All material 3 inches in width.

Table XVII VALUES OF POISSON'S RATIO FOR  
CELLULOSE ACETATE AND ACRYLIC SHEET AT VARIOUS DEFORMATIONS

Mat.	Test No.	Longitudinal Deformation, Percentage of Original Length	Poisson's Ratio	
Cellulose Acetate (275° F)	1	32	0.40	
		35	0.38	
		43	0.36	
	2	33	0.43	
		40	0.42	
		59	0.32	
		84	0.27	
		100	0.25	
	3	33	0.44	
		47	0.35	
		70	0.26	
		85	0.26	
		105	0.22	
	Acrylic Sheet (375° F)	1	13	0.21
			40	0.37
64			0.31	
2		11	0.31	
		31	0.43	
		53	0.38	
		70	0.35	
		77	0.33	
3		135	0.25	
		56	0.36	
		81	0.32	
		127	0.28	
		168	0.18	
155		0.24		

# Contrails

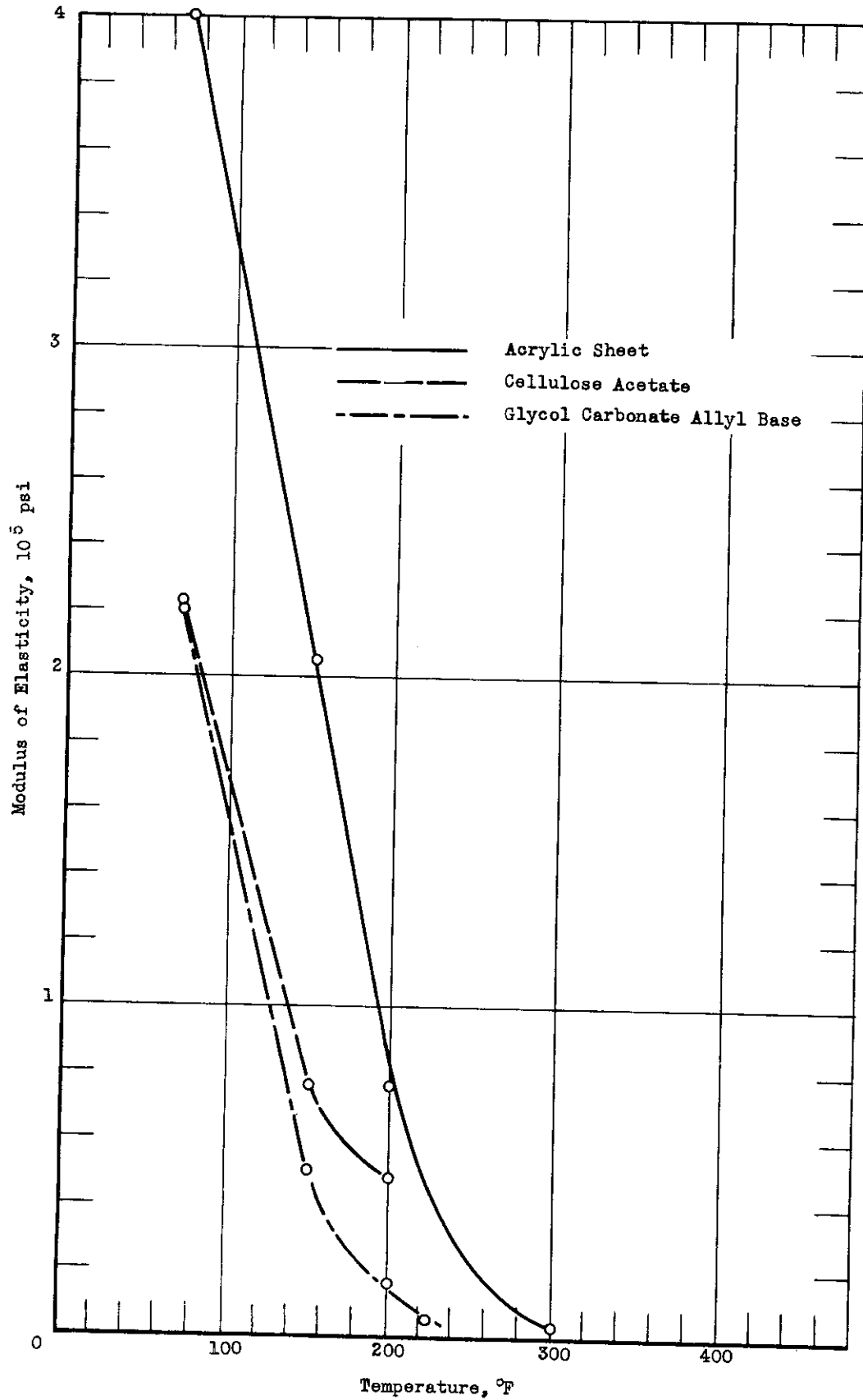
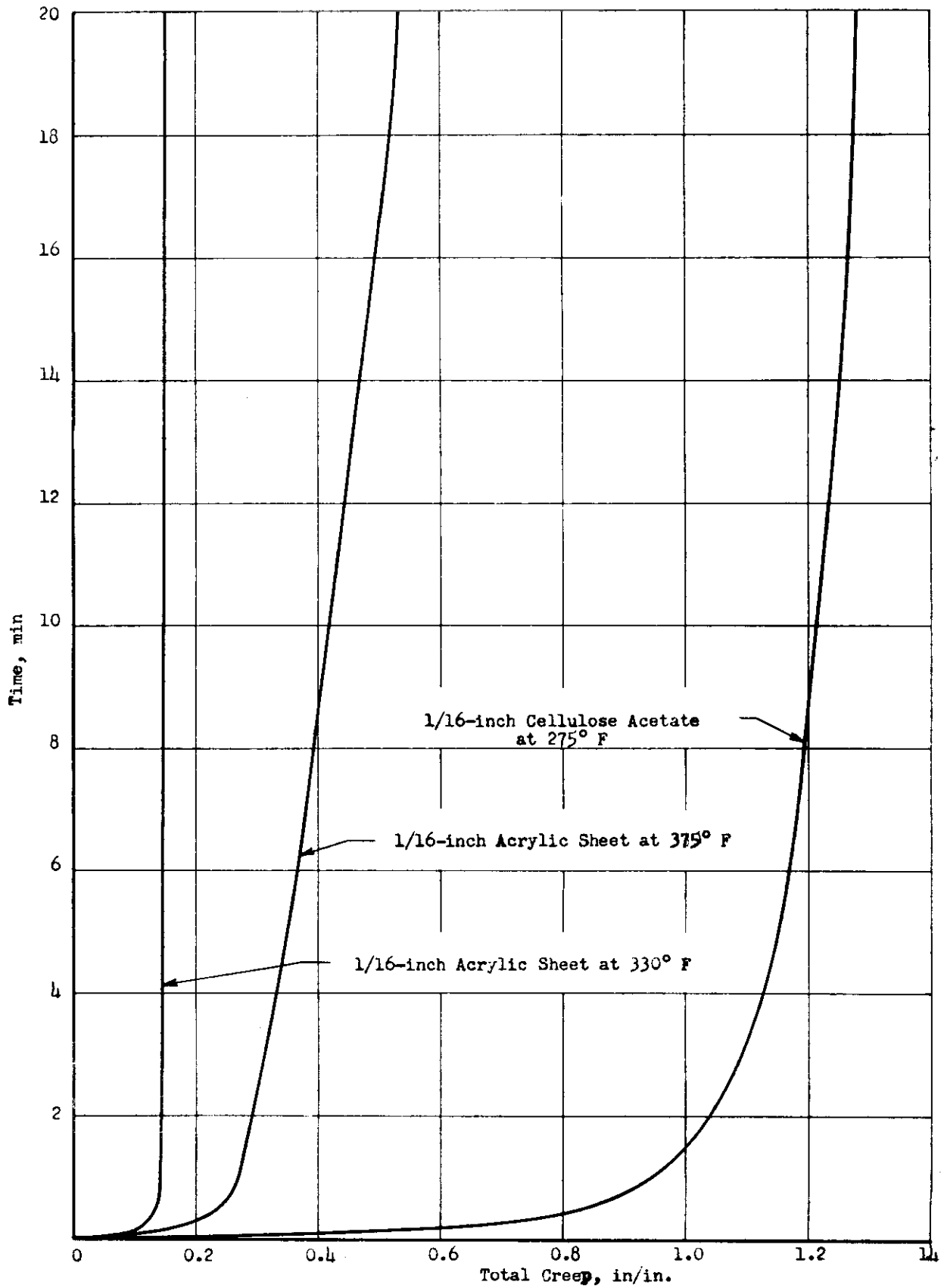

Fig. 1. MODULUS OF ELASTICITY VERSUS TEMPERATURE





**Fig. 2 CREEP TESTS, CELLULOSE ACETATE AND ACRYLIC SHEET**

(Stress = 100 psi)

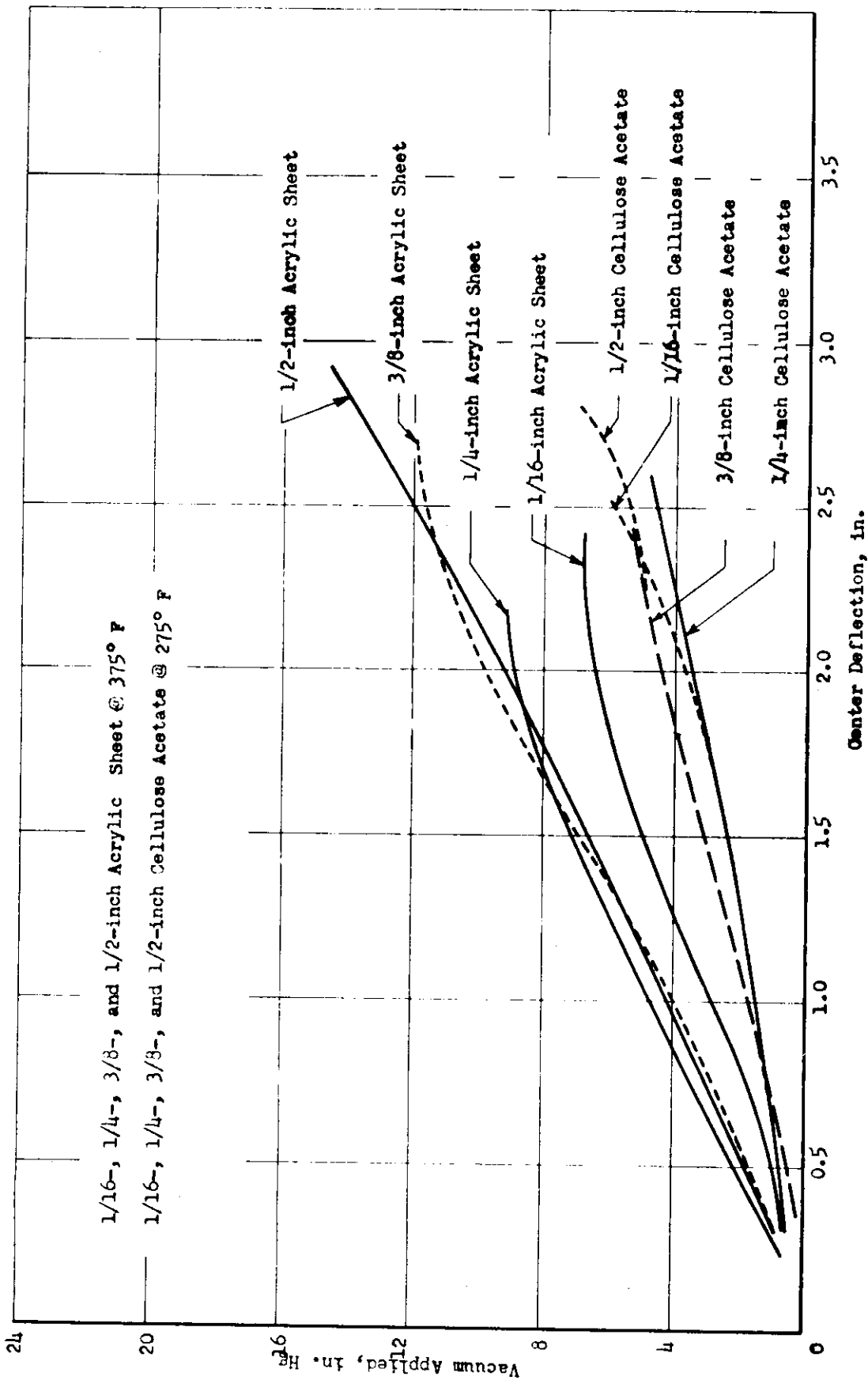
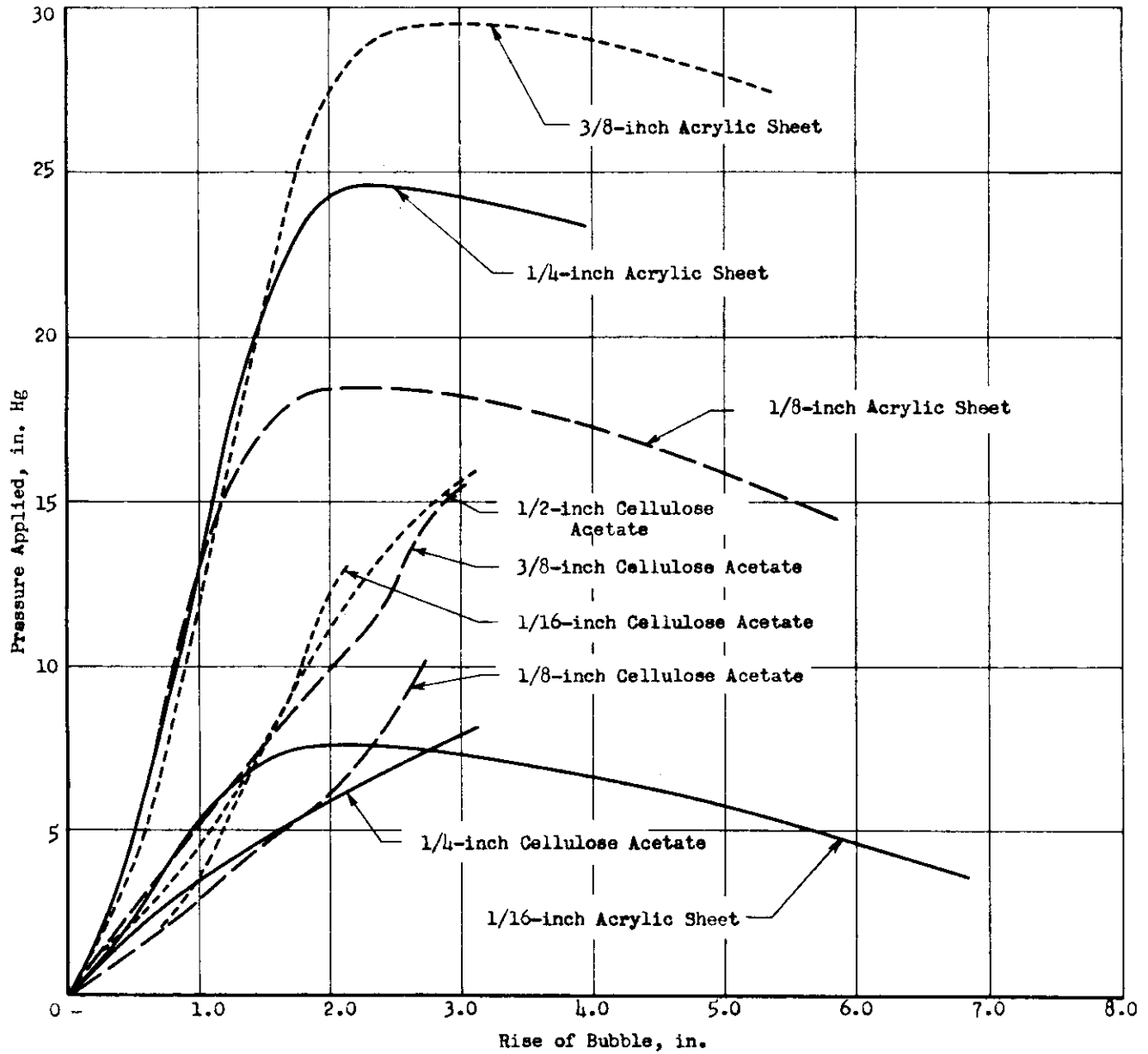

FIG. 3 VACUUM VERSUS FORMING OF BUBBLE DRAWN INTO 6-INCH HEMISPHERE

# Contrails



**Fig. 4 PRESSURE-DEFORMATION CURVES FROM UNCONFINED BUBBLE TEST, 4-INCH DIAMETER BASE**

# Contrails

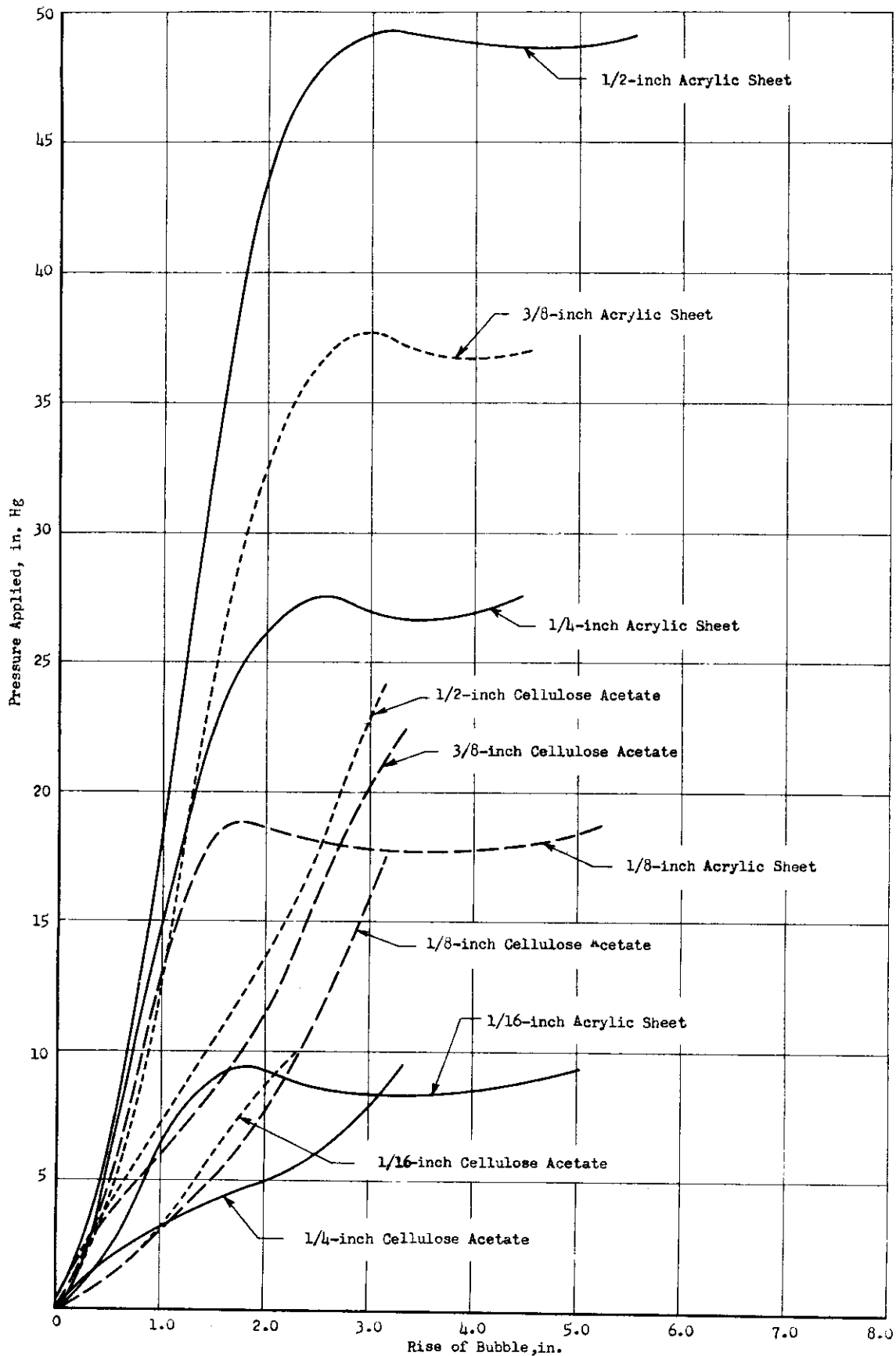
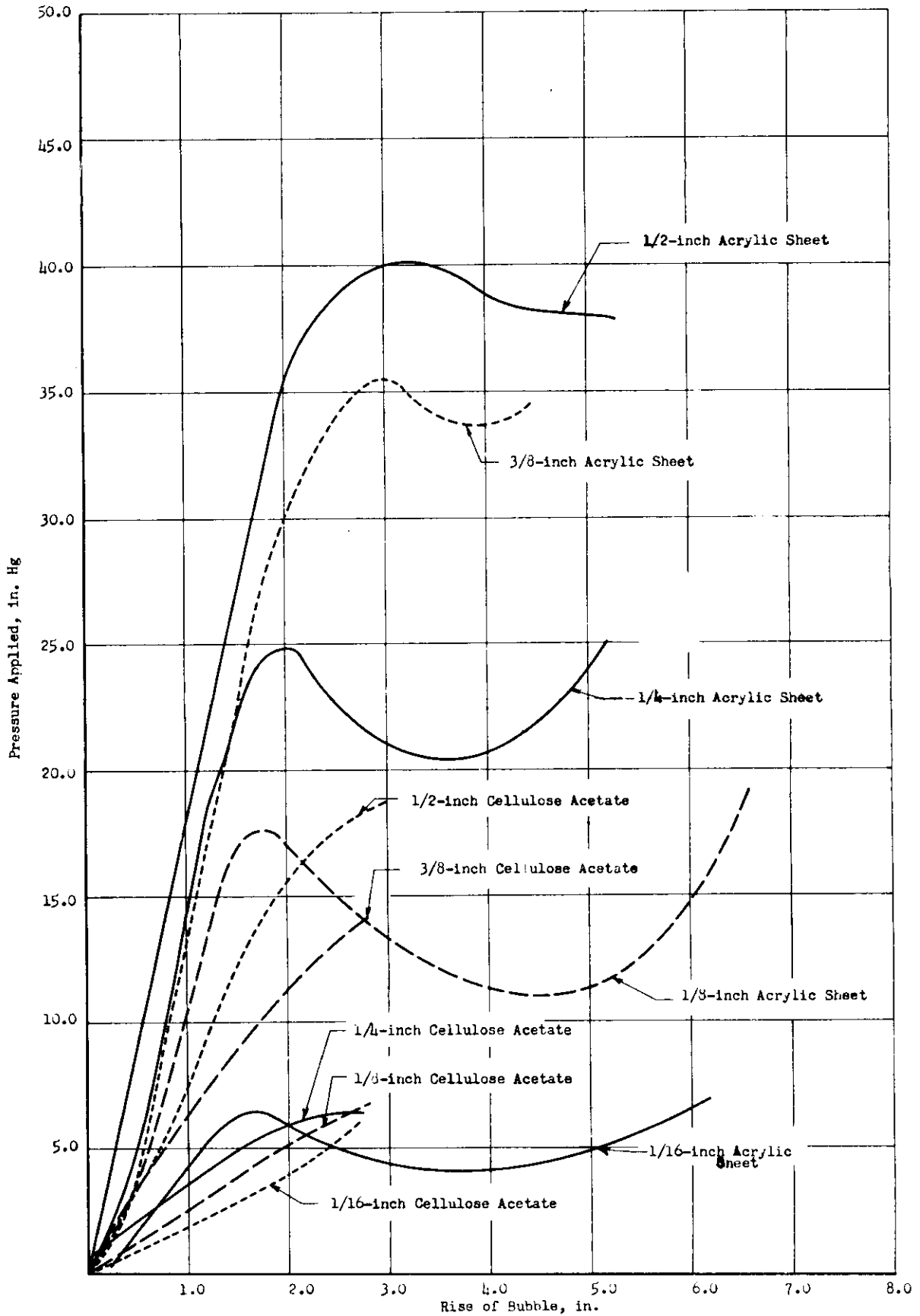

Fig. 5 PRESSURE-DEFORMATION CURVES FROM CONFINED BUBBLE TEST, 4-INCH DIAMETER BUBBLE IN 4-INCH TUBE

# Contrails



**Fig. 6** PRESSURE-DEFORMATION CURVES FROM UNCONFINED BUBBLE TEST, LUBRICATED SPECIMEN, 4-INCH DIAMETER AT BASE

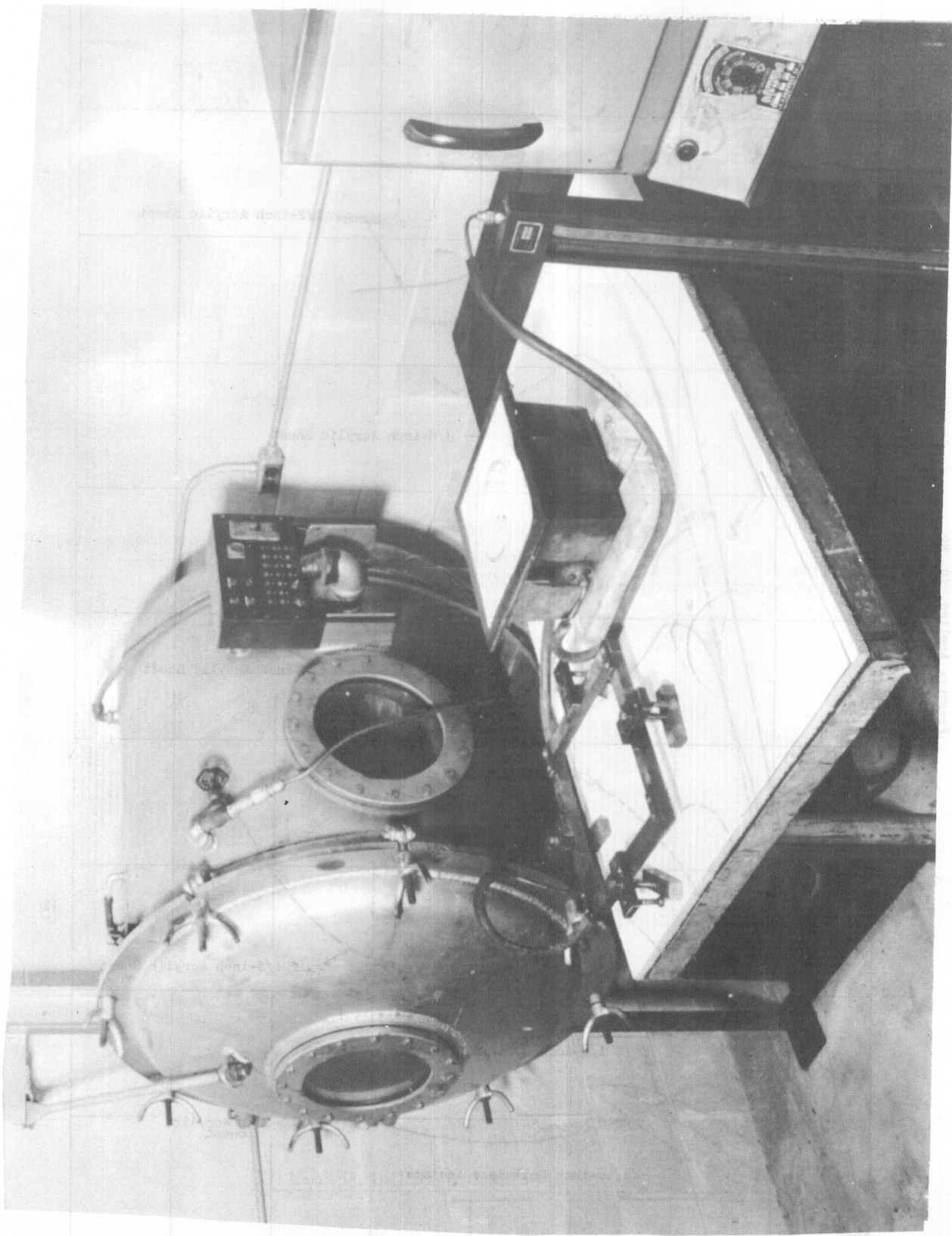

Fig. 7 GENERAL VIEW OF HEMISPHERE DRAWING APPARATUS

WADC TR 53-19

54

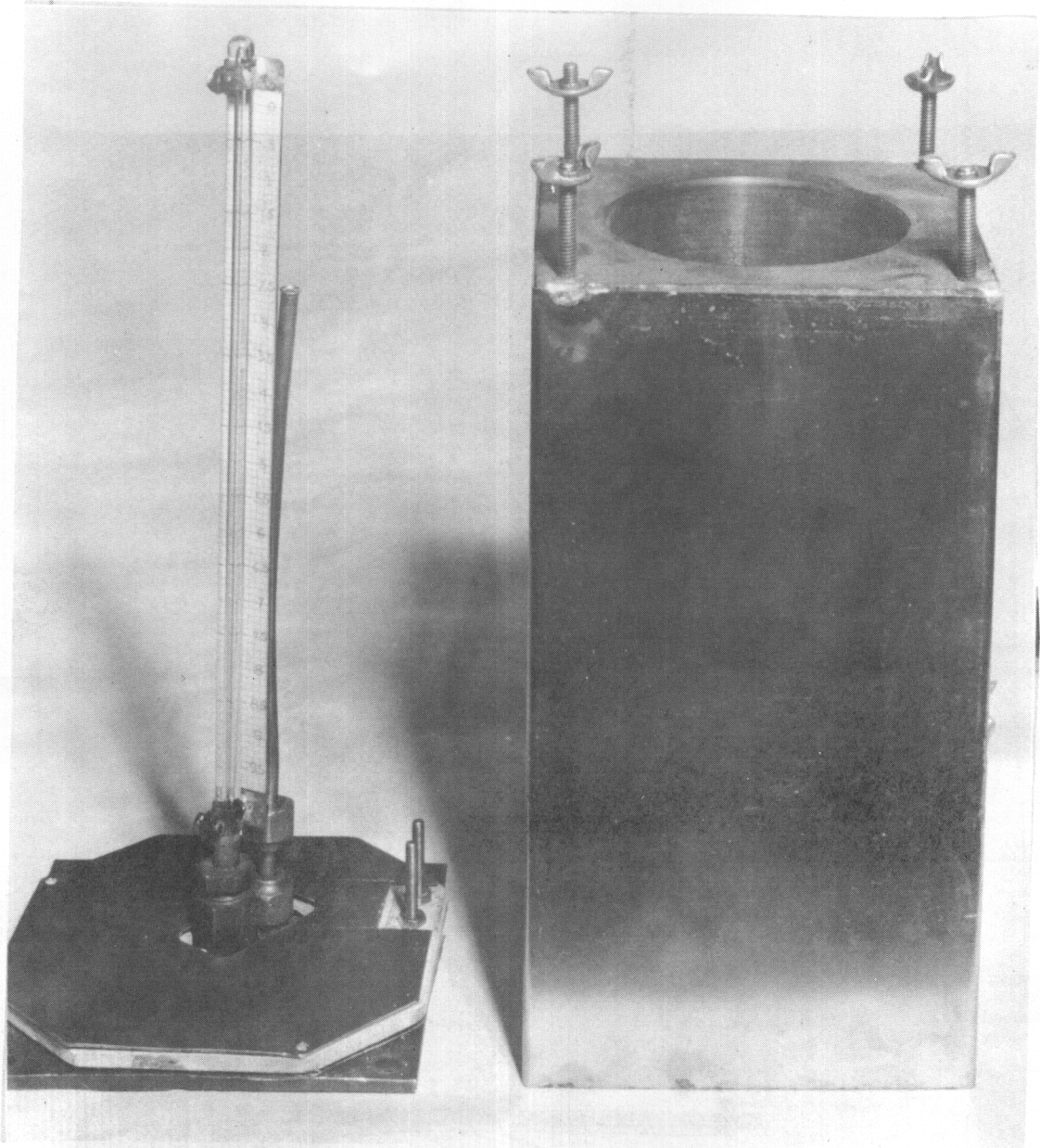

Fig. 8 CONFINED BUBBLE TESTING APPARATUS

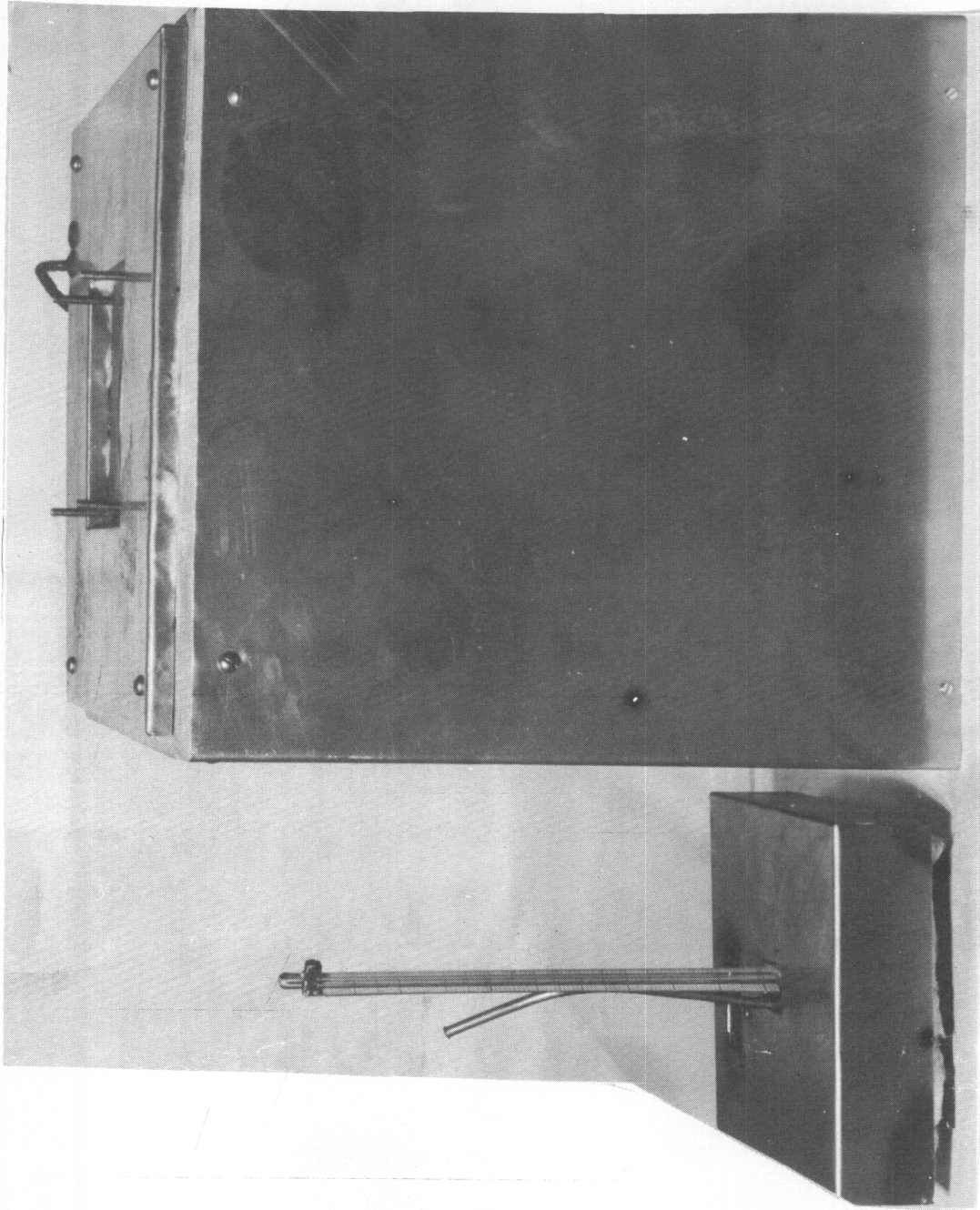

Fig. 9 UNCONFINED BUBBLE TESTING APPARATUS



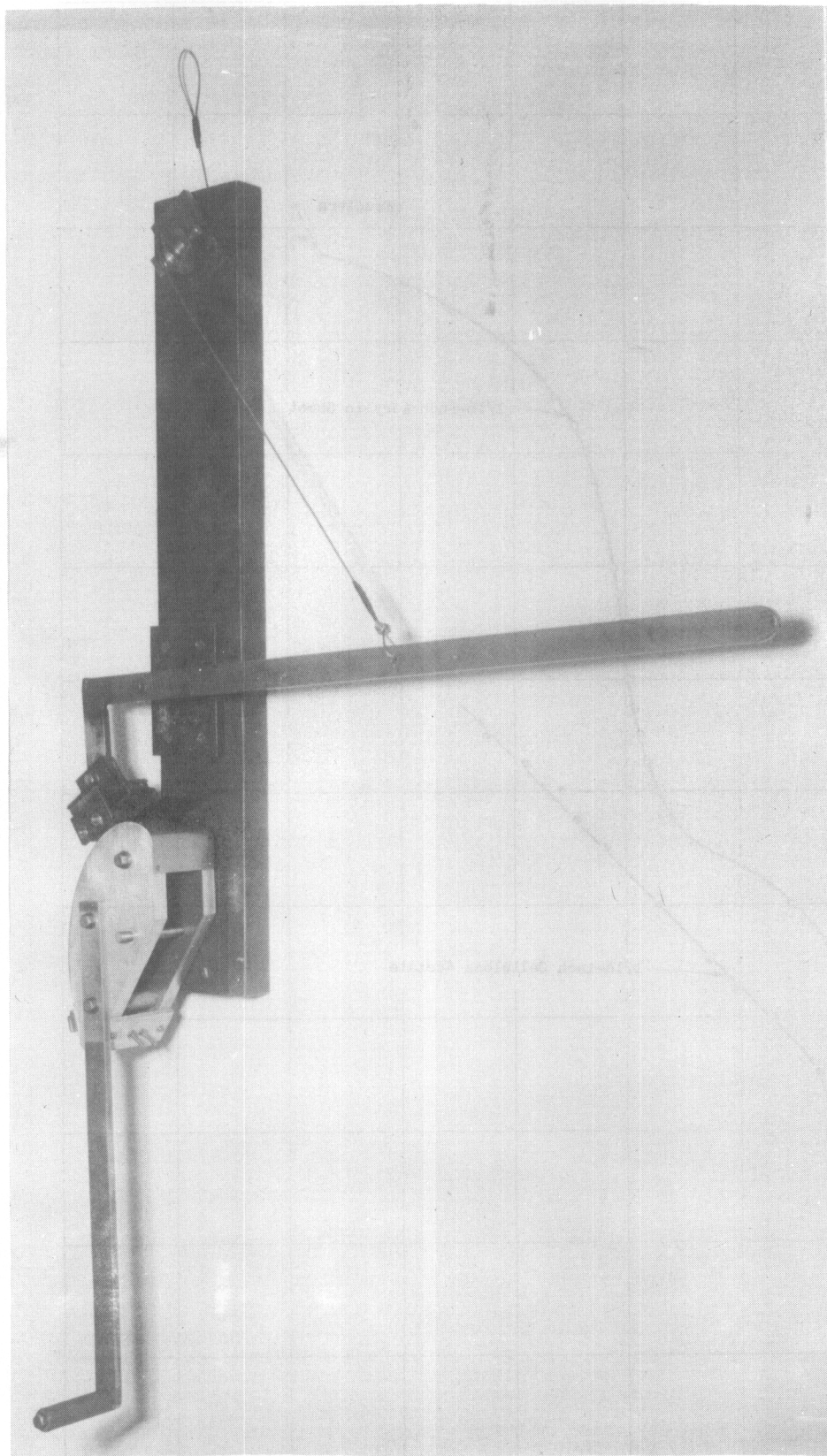

FIG. 10 BEND TESTING APPARATUS FOR THERMOSETTING PLASTICS

# Contrails

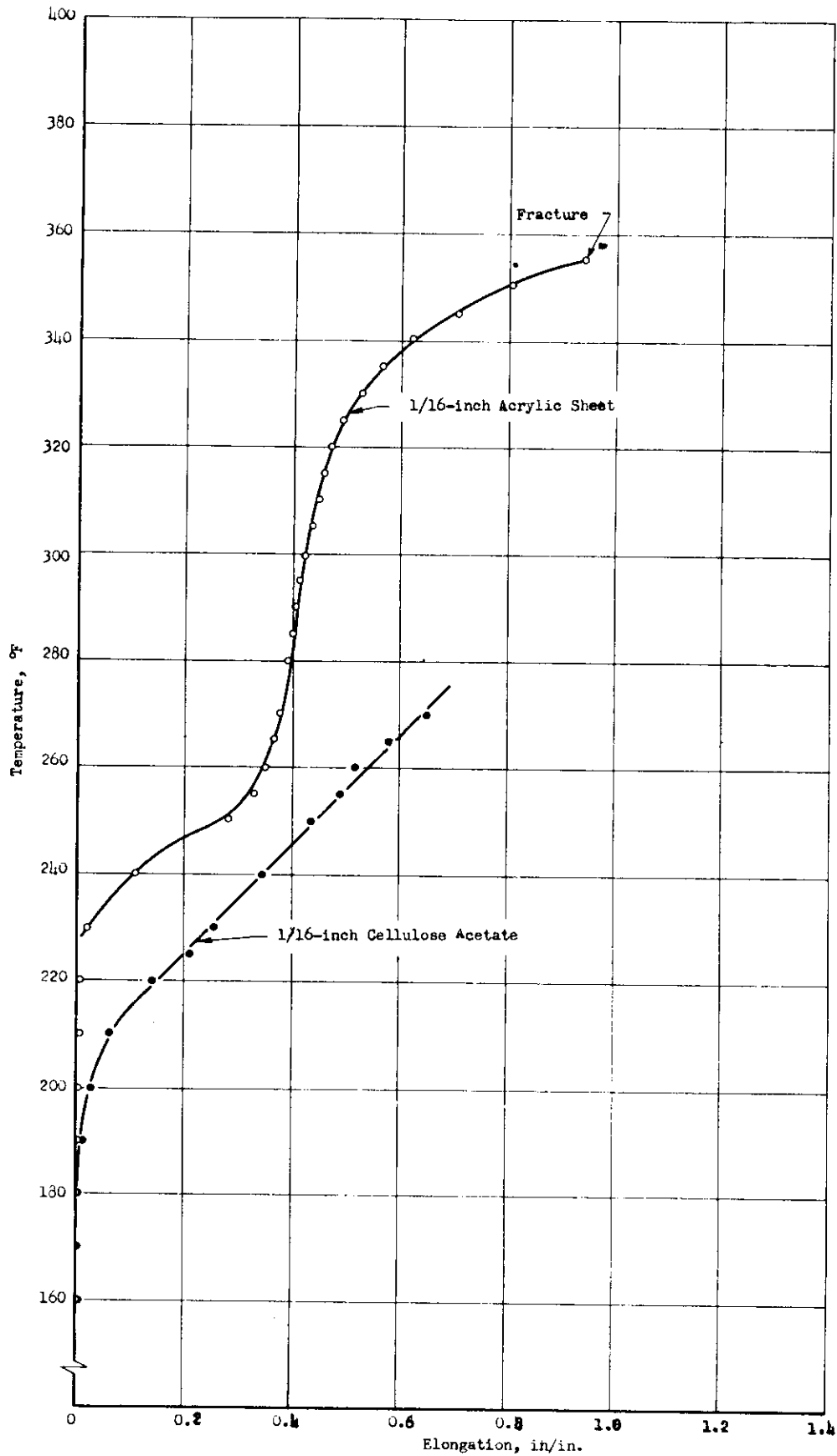

Fig. 11 TEMPERATURE-DEFORMATION CURVE FOR 1/16-INCH ACRYLIC SHEET AND 1/16-INCH CELLULOSE ACETATE

(Constant Stress = 100 psi)

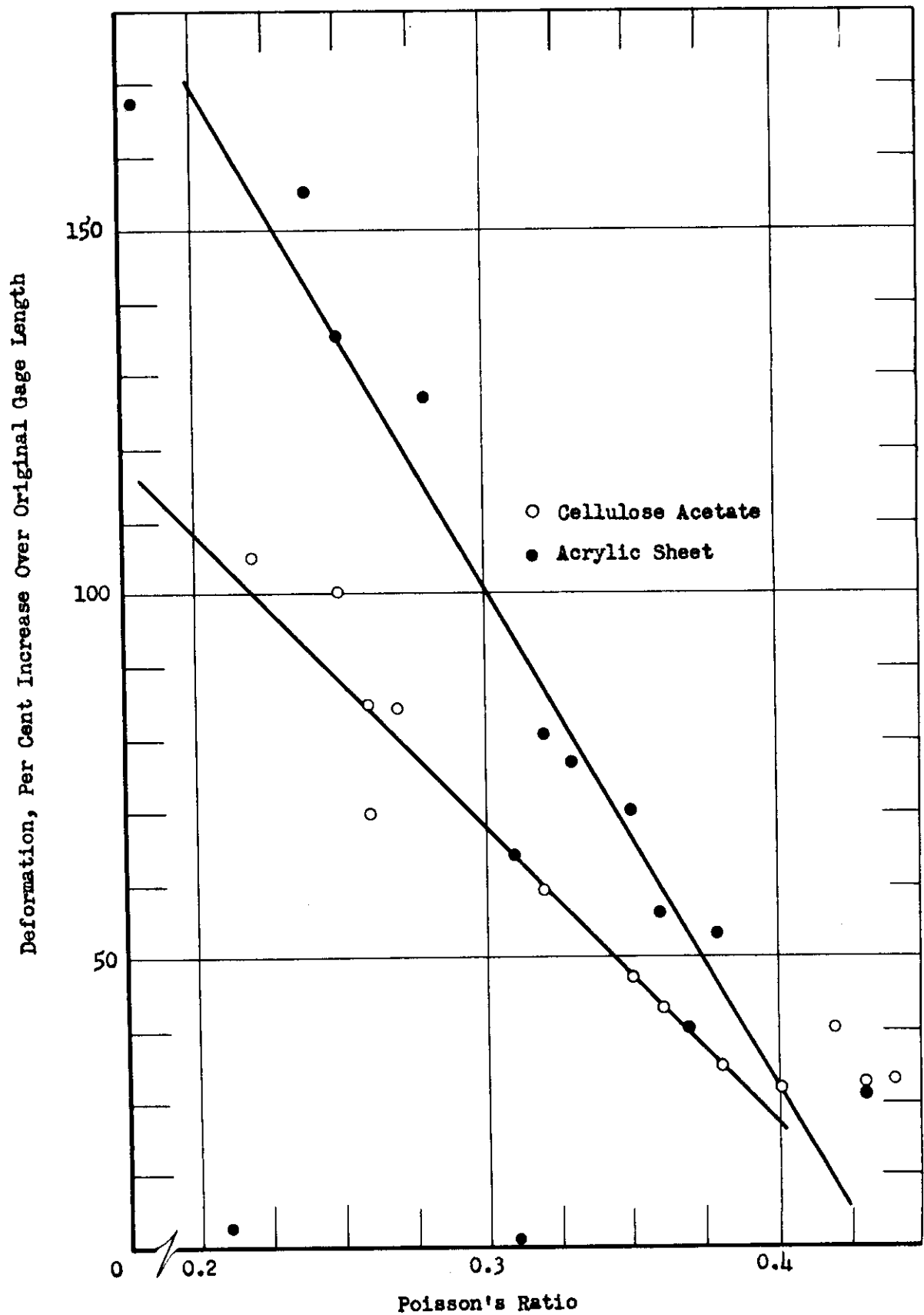

Fig. 12 POISSON'S RATIO VERSUS DEFORMATION

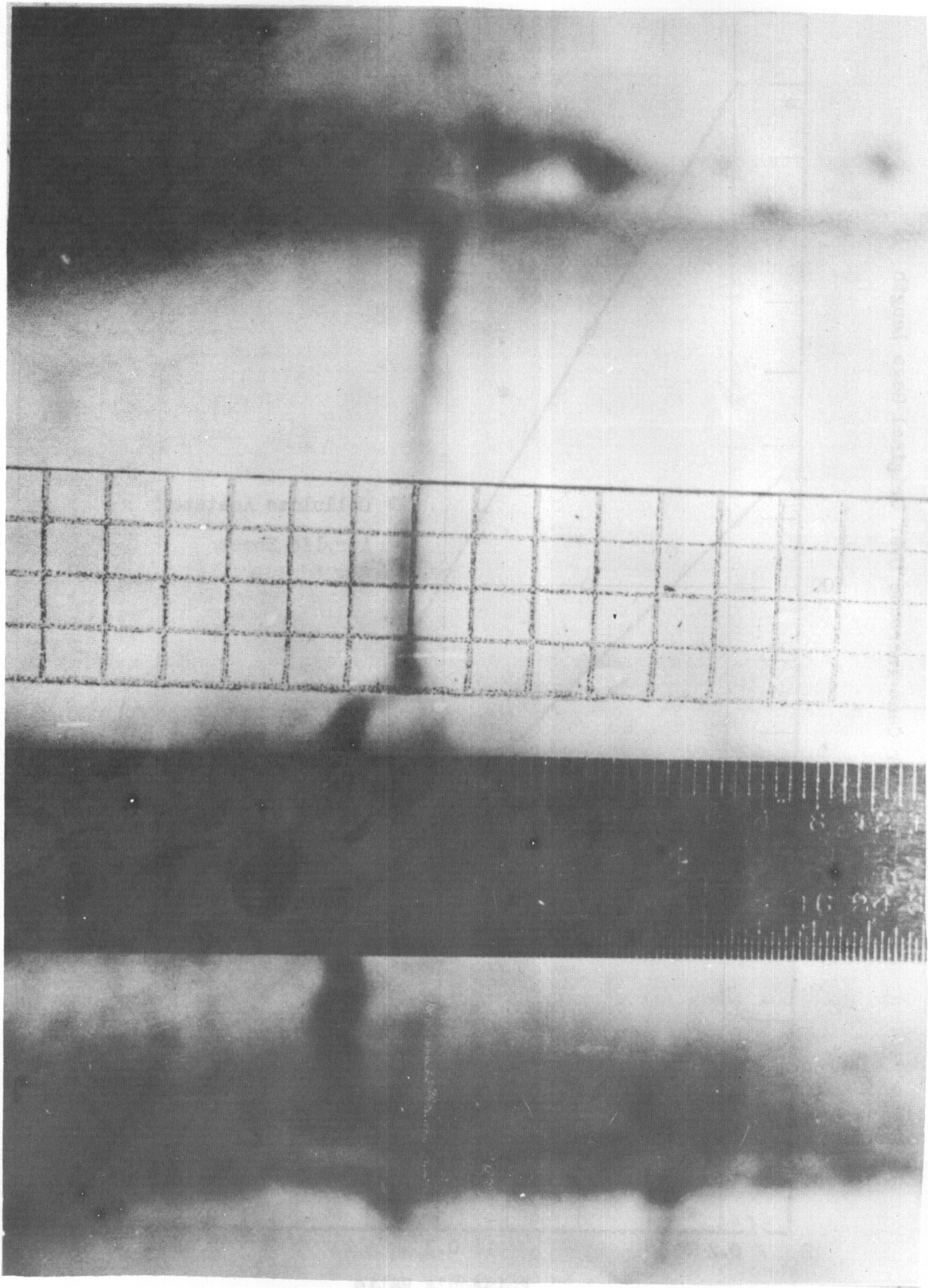

Fig. 13 EXAMPLE OF PHOTOGRAPHIC ENLARGEMENT  
USED IN DETERMINATION OF POISSON'S RATIO AT VARIOUS STRAINS

## APPENDIX A

### CURVE FOR BEND FORMING TESTS

Eugene L. Chez

A curve is desired such that

$$\frac{dR}{ds} = 1,$$

in which

R = radius of curvature and

s = distance along curve.

In polar coordinates,

$$R = \frac{\left[ \rho^2 + \left( \frac{d\rho}{d\theta} \right)^2 \right]^{3/2}}{\rho^2 + 2 \left( \frac{d\rho}{d\theta} \right)^2 - \rho \frac{d^2\rho}{d\theta^2}},$$

and

$$ds = \left[ d\rho^2 + \rho^2 d\theta^2 \right]^{1/2}.$$

Let us try a solution of logarithmic or equiangular spiral, the equation for which is

$$\rho = ke^{a\theta}.$$

Differentiating twice with respect to  $\theta$ ,

$$\frac{d\rho}{d\theta} = a ke^{a\theta} = \rho a$$

$$d\rho = \rho a d\theta.$$

$$\frac{d^2\rho}{d\theta^2} = a^2 ke^{a\theta} = \rho a^2.$$

$$\rho \frac{d^2\rho}{d\theta^2} = \rho^2 a^2$$

# Contraails

Substituting the preceding values into their respective equations,

$$R = \frac{(k^2 e^{2a\theta} + a^2 k^2 e^{2a\theta})^{3/2}}{k^2 e^{2a\theta} + 2(a^2 k^2 e^{2a\theta}) - a^2 k^2 e^{2a\theta}} = \frac{(\rho^2 + a^2 \rho^2)^{3/2}}{\rho^2 + 2a^2 \rho^2 - a^2 \rho^2} = \frac{[\rho^2(1 + a^2)]^{3/2}}{\rho^2(1 + a^2)}$$

Therefore,

$$R = \rho (1 + a^2)^{1/2}.$$

Hence

$$dR = (1 + a^2)^{1/2} d\rho$$

and

$$\frac{dR}{d\theta} = (1 + a^2)^{1/2} \frac{d\rho}{d\theta}.$$

Also,

$$\begin{aligned} ds &= (a^2 k^2 e^{2a\theta} d\theta^2 + k^2 e^{2a\theta} d\theta^2)^{1/2} = (a^2 \rho^2 d\theta^2 + \rho^2 d\theta^2)^{1/2} \\ &= (1 + a^2)^{1/2} \rho d\theta. \end{aligned}$$

Proceeding now to the solution of the original equation,

$$\frac{dR}{ds} = \frac{\frac{dR}{d\theta}}{\frac{ds}{d\theta}} = \frac{dR}{d\theta} \cdot \frac{d\theta}{ds} = \left[ (1 + a^2)^{1/2} \rho a \right] \left[ \frac{1}{\rho(1 + a^2)^{1/2}} \right] = a.$$

It follows that for

$$\frac{dR}{ds} = 1,$$

$$a = 1.$$

The final equations which meet the required conditions are

$$\rho = k e^{\theta}.$$

If  $k = 1/4,$

$$\rho = \frac{e^{\theta}}{4}; \quad R = \frac{\sqrt{2} e^{\theta}}{4}; \quad \text{and} \quad s = \frac{\sqrt{2} e^{\theta}}{4}.$$

APPENDIX B

DRAWINGS OF TEST APPARATUS FOR THERMOSETTING AND THERMOPLASTIC MATERIALS

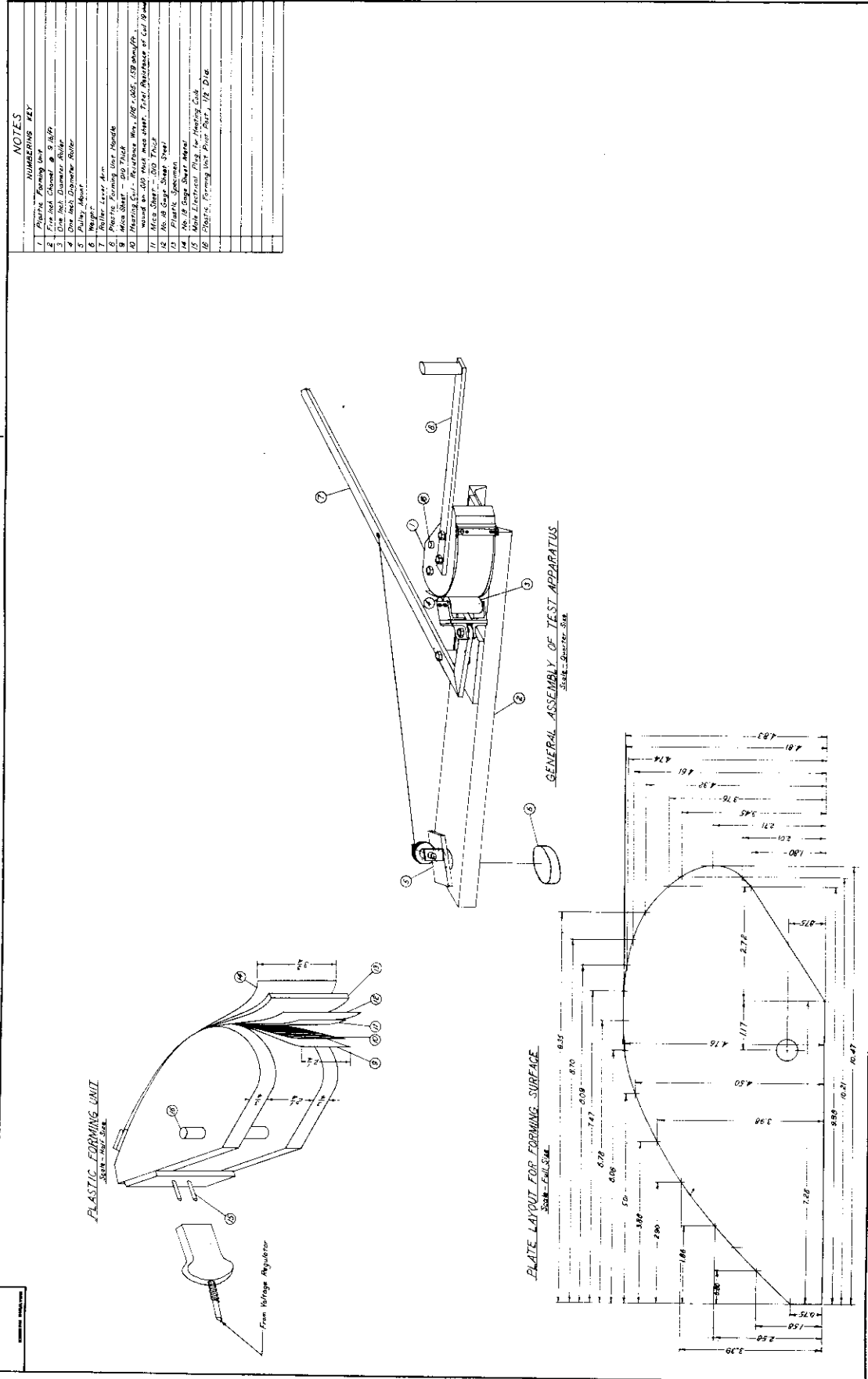
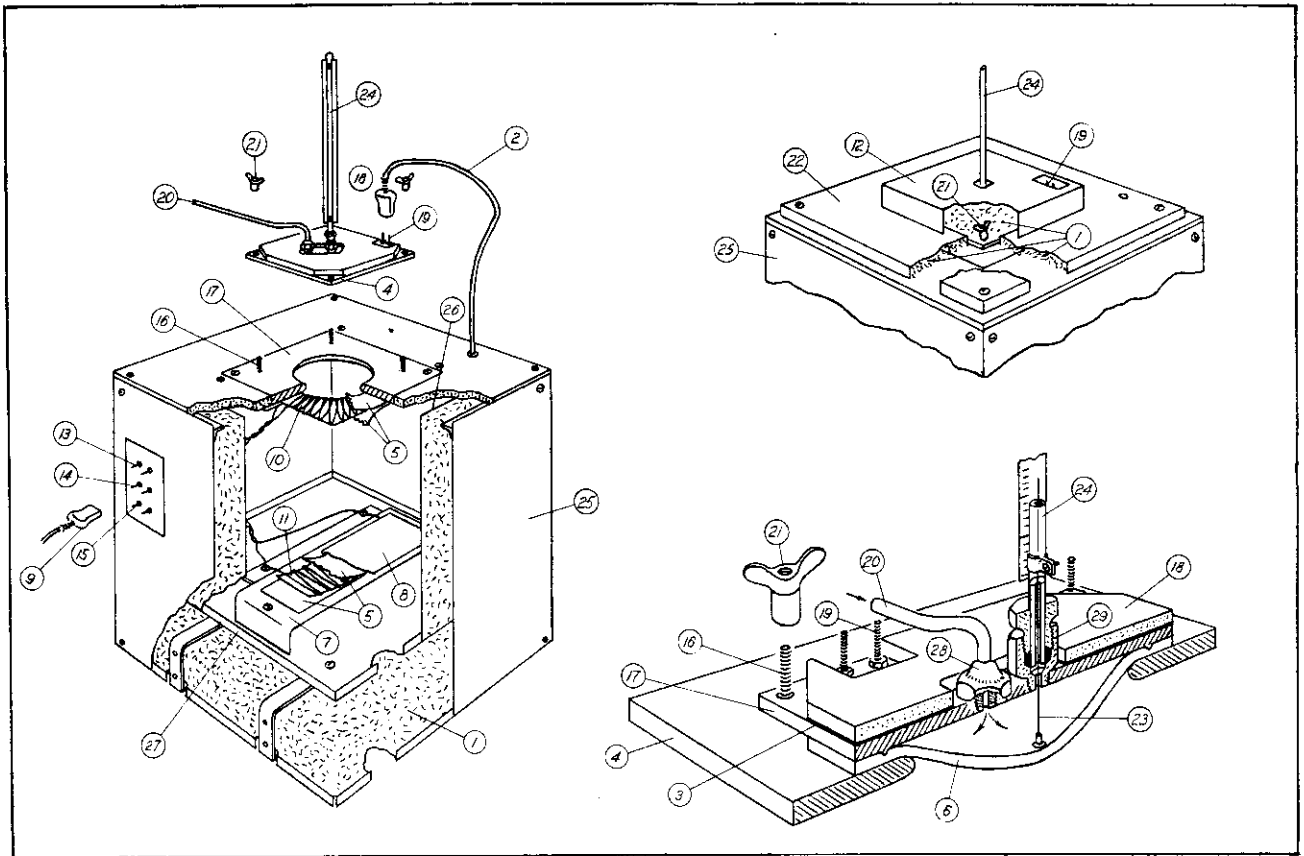

Fig. B-1 FORMING TEST APPARATUS FOR THERMOSETTING PLASTIC





NOTES	
NUMBERING KEY	
1	Glass Wool Insulation
2	Card to Clamping Cover Heating Unit
3	Clamping Cover Heating Coil - Resistance Wire, $1/16 \times .005$ , 1.59 ohms/ft, wound on .010 mica sheet, Total Resistance of Coil 17.5 ohms
4	Orifice Plate - 4 inch diameter hole in $1/8$ inch plate
5	Mica Sheet - .010 thick
6	Plastic Test Specimen
7	No. 18 Gage Steel Bottom Heating Coil Support
8	No. 18 Gage Steel Heating Coil Cover Plate
9	Electrical Connection From Voltage Regulator
10	Forming Plate Heating Coil - Resistance Wire, $1/16 \times .005$ , 1.59 ohms/ft, wound on .010 mica sheet, Total Resistance of Coil 29 ohms
11	Chamber Heating Coil - Resistance Wire, $1/16 \times .005$ , 1.59 ohms/ft, wound on .010 mica sheet, Total Resistance of Coil 28.5 ohms
12	No. 18 Gage Steel Cover - 8 in. $\times$ 6 in. $\times$ 2 in.
13	Terminal for Clamping Cover Heating Coil
14	Terminal for Forming Plate Heating Coil
15	Terminal for Chamber Heating Coil
16	$1/4$ Inch Clamp Down Bolt
17	$3/16$ Inch Specimen Seal Plate
18	$1/4$ Inch Transite Heat Insulator Plate
19	Electrical Terminal for Clamping Cover Heating Unit
20	$1/4$ Inch Diameter Air Inlet Tube
21	$1/4$ Inch Clamp Down Wing Nut
22	No. 18 Gage Steel Cover - 15 in. $\times$ 15 in. $\times$ $1/2$ in.
23	Plastic Bubble Depth Probe
24	Plastic Bubble Depth Indicator - $1/8$ Inch Outside Diameter Glass Tube
25	No. 18 Gage Steel Outside Shell - 16 in. $\times$ 16 in. $\times$ 16 in. - of main container
26	No. 18 Gage Steel Inside Shell - 12 in. $\times$ 12 in. $\times$ 13 in. - of main container
27	No. 18 Gage Steel Inner Bottom
28	$1/4$ Inch Standard Copper Tubing Fitting
29	Packing Gland

**Fig. B-2 FORMABILITY EVALUATION UNIT FOR THERMOPLASTIC MATERIAL**