

# *Contrails*

## SECTION III

SESSION 1: A REVIEW OF THE CURRENT  
SPECIFICATION, ITS USES, AND PROBLEMS

# *Contrails*

# Contrails

## EVALUATION OF SELECTED CLASS III REQUIREMENTS OF MIL-F-8785B (ASG), "FLYING QUALITIES OF PILOTED AIRPLANES"

C. C. Withers\*  
Lockheed-Georgia Company  
Marietta, Georgia

### ABSTRACT

In 1969, the Air Force Flight Dynamics Laboratory issued a complete revision to the Military Specification, "Flying Qualities of Piloted Airplanes." This specification, MIL-F-8785B(ASG) has not yet been applied to the design or test of an operational, heavy-weight, cargo aircraft. In 1975, the Lockheed-Georgia Company completed a study program for the Flight Dynamics Laboratory in which C-5A flight test results were used to validate the requirements of MIL-F-8785B(ASG). The results of this study show that there are seven areas where the requirements of MIL-F-8785B(ASG) appear to be too stringent. Since completion of the C-5A program, the Lockheed-Georgia Company Flight Test Division instigated a study effort to compare selected sections of MIL-F-8785B(ASG) with flight test results from the C-5A, L-1011, C-141A, and YC-141B (Stretch C-141A).

### INTRODUCTION

Results of the C-5A study effort presented, in Reference 1, indicate that the requirements of MIL-F-8785B(ASG) are too stringent for Class III airplanes in the following seven sections:

- 3.2.1.2 Phugoid Stability
- 3.2.2.1 Short Period Response
- 3.2.2.2 Control Forces in Maneuvering Flight
- 3.3.1.1 Lateral Directional Oscillations
- 3.3.1.2 Roll Mode ( $T_R$ )
- 3.3.2.4 Sideslip Excursions
- 3.3.4 Roll Control Effectiveness

This paper presents a comparison of the requirements for the above sections of MIL-F-8785B(ASG) with flight test results from the C-5A, L-1011, C-141A, and YC-141B.

---

\*Clifton C. Withers is an Aircraft Development Specialist in Engineering Flight Test at the Lockheed-Georgia Company. The author thanks C. A. Whitmore and A. L. Byrnes of the Lockheed-California Company for their efforts in supplying L-1011 data.

## AIRPLANE DESCRIPTION

### C-5A

The C-5A is a long-range, all weather, high-altitude, high-subsonic, swept-wing, T-tailed airplane designed for use as a heavy logistic transport with relatively short-field takeoff and landing capability. The airplane is designed to airlift a wide variety of combat support equipment and personnel at payloads of up to 265,000 pounds. Aircraft gross weight ranges from 319,809 pounds empty to 769,000 pounds maximum design weight. Initial cruise altitude is 30,000 feet with cruise speeds of up to 470 knots true airspeed. It is powered by four General Electric TF-39 turbofan engines equipped with thrust reversers. Inflight reverse thrust is applied to the inboard engines for rapid or emergency descent. A retractable, high-flotation landing gear consisting of four six-wheel, bogie-type, main landing gears and a four-wheel, steerable nose gear enables the airplane to operate from paved or unpaved runways. The landing gear can be set at "crabbed" positions for takeoffs and landings in crosswinds. Some of the other unique design features of the airplane are a forward and aft cargo door system which enables straight-through loading and unloading, and a landing gear kneeling system. The kneeling system permits the cargo deck to be tilted nose-down or tail-down, or to be lowered in the level position. Aerial delivery of payloads through the aft cargo door is possible. Up to 200,000 pounds of payload may be dropped in multiple packages, and a single package of 86,000 pounds has been dropped in demonstration tests. Two auxiliary power units, one located in each main landing gear pod, are provided to supply electrical, pneumatic, and hydraulic power (through use of air turbine motors) for engine starting and for ground operation and maintenance requirements. Figure 1 presents a three-view drawing of the basic airplane.

Primary flight controls include ailerons, spoilers, rudders, and elevators. All surface hinge moments are provided by hydraulically powered actuators, and pilot "feel" is artificial. Control wheels, columns, and rudder pedals provide pilot or copilot inputs to the control valves through the mechanical linkage and cable systems. Hydraulic power is provided by four independent systems. Secondary flight controls include ground spoilers, leading-edge slats, pitch trim, and trailing-edge flaps.

Pitch and yaw/lateral SAS (Stability Augmentation Subsystem) are provided. Pitch SAS provides short-period pitch damping, Yaw/lateral SAS provides yaw damping, turn coordination, and spiral divergency control. The C-5 SAS is triple redundant, fail safe/fail operational. The actuator inputs are added in series with pilot inputs to control the surface actuators. The aircraft can be flown safely without SAS.

### C-141A/YC-141B

The C-141A Starlifter is a long-range, high-subsonic, high-altitude, swept-wing, T-tailed airplane designed for use as a heavy logistic transport. The airplane is designed to airlift cargo or military personnel at payloads up to 70,000 pounds. Operating gross weight ranges from 130,000 pounds to 318,000 pounds maximum ramp weight. Design landing gross weight is 257,500 pounds with a maximum load factor of 2.5 g's.

# Contrails

The aircraft is powered by four Pratt & Whitney JT3D-5A (TF33-P-7 Military) turbofan engines which have twin-spool, axial-flow compressors. The engines, which are flat-rated at 21,000 pounds of thrust, are mounted individually in nacelles suspended below the wings. Each engine is equipped with target-type thrust reverser doors which are used only for a ground deceleration.

The aircraft is equipped with a fully retractable tricycle landing gear. The landing gear consists of two "four-wheel" bogie-type main gears which mount dual wheels forward and aft of the shock strut (in pods on each side of the aircraft) and a steerable, dual nose wheel. Anti-skid braking protection is installed on all main landing gear wheels.

Primary flight controls include ailerons, rudder, and elevator. All surface hinge moments are provided by hydraulically powered actuators, and pilot "feel" is artificial. Hydraulic power is provided by four independent systems. Secondary flight controls include flight/ground spoilers, pitch trim, and trailing-edge flaps. Stability augmentation consists of a yaw damper, but the airplane can be flown without the yaw damper operating. A "Q" feel system is incorporated in the longitudinal control system to provide positive speed stability.

Figure 2 presents a three-view drawing of the C-141A.

The YC-141B is similar to the C-141A with the following major modifications:

- o The fuselage length is increased 280 inches by adding a 160-inch plug forward of the wing and a 120-inch plug aft of the wing.
- o An aerial refueling receiver system using the Universal Aerial Refueling Receptacle Slipway Installation (UARRSI) is installed atop the fuselage in an aerodynamic fairing.

## L-1011-100

The L-1011-100 is designed for transcontinental as well as short- and medium-range operation to handle high-density traffic markets. Primary features are the large spacious fuselage and application of the advanced technology high-bypass-ratio engines with low fuel consumption and low community noise. The general arrangement of the L-1011-100 with three Rolls-Royce RB-211-22-B engines is shown in Figure 3. The L-1011-100 is capable of operations at ranges up to 3735 nautical miles with a payload of 57,700 pounds at a normal cruise speed of Mach 0.85. Maximum takeoff gross weight is 466,000 pounds with an operational empty weight of 246,200 pounds. Maximum load factor in the cruise configuration is 2.5g's. Primary flight controls consist of an all movable stabilizer and geared elevator, a rudder, inboard and outboard ailerons, and spoilers for deceleration and roll control. The spoilers are also used for direct lift control for flaps-down operation. The pilot's control forces in pitch, yaw, and roll are artificially supplied by feel springs. Secondary flight controls include ground spoilers, leading-edge slats, pitch trim, trailing-edge flaps, directional trim and lateral trim. The

# Contrails

stability augmentation consist of a yaw damper and a Mach trim compensator.

## DISCUSSION OF TEST RESULTS

The C-5A and C-141A stability and control data used in this paper were obtained during combined Lockheed and Air Force Category I/II test programs. The C-5A test results are presented in Reference 2, and the C-141A data are presented in Reference 3. The YC-141B data discussed herein were obtained during the recently completed Lockheed/Air Force YC-141B Development Flight Test Program, and these data are presented in Reference 4. The L-1011 results were computed from basic aerodynamic data as updated from the Flight Test Certification Program.

The scope of this paper does not permit the inclusion of all applicable airplane configurations and failure states relative to the seven sections listed in the Introduction. In most instances only cruise configuration (Category B) data are discussed. However, where convenient, landing and approach configuration (Category C) data are also included. Additionally, all data are applicable to Level 1 conditions except the data for the lateral-directional damping section. These data were obtained with the yaw damper inoperative, and it is assumed that the results correspond to Level 2 requirements.

### Phugoid Stability

Results from C-5A, C-141A, YC-141B, and L-1011 phugoid stability tests are presented in Figure 4 in terms of damping ratio versus undamped natural frequency of the phugoid oscillation. The MIL-F-8785B(ASG) Level 1 requirement, which states that  $\zeta_p$  shall be at least 0.04, is also presented for comparison. The C-5A, C-141A, and L-1011 data are applicable for both forward and aft center of gravity positions; the YC-141B data are for aft c.g. only. The data presented in Figure 4 show that the C-5A and L-1011 do not comply with the minimum damping ratio requirement of 0.04. Pilot comments for the C-5A corresponding to these results average about 3.5 which are for Level 1 conditions. General pilot comments for the L-1011 indicate values similar to the C-5A.

For the Level 2 test conditions, the damping ratio is permitted to drop to zero with a corresponding degradation in pilot rating. Here the inconsistency appears to exist in the specification requirements for a Class III airplane. Test results correspond to Level 2 requirements, but the pilot ratings correspond to Level 1 requirements. This inconsistency is considered to exist because of the period  $\omega_{np}$  has not been taken into consideration. The C-5A results which fell below the 0.04 damping requirement had a period of at least one minute, which probably affected pilot ratings considerably. Therefore, it is concluded that the 0.04 damping requirement for Level 1 should be relaxed provided that the frequency of the oscillation is low enough not to affect trimmability or longitudinal control. It is also evident from these data that the application of MIL-F-8785B(ASG) longitudinal phugoid requirements to the C-5A initial design, in lieu of MIL-F-8785(ASG) requirements, would have had an insignificant effect on overall pilot ratings but would have had a significant effect on the initial design and resulting cost.

# Contrails

## Short-Period Response

Short-period response characteristics for the four airplanes are shown in Figure 5 in terms of the undamped natural frequency of the short-period oscillation versus the normal acceleration change per unit change in angle of attack, along with the specification requirements for the Category B flight phase. These data show that the C-141A and YC-141B comply with the Level 1 requirements but that the C-5A and L-1011 do not.

Based on the C5-A and L-1011 short-period data presented herein, the Level 1 and Level 2 frequency requirement envelopes appear to be too high for all Flight Phase categories for a Class III airplane. Pilot comments indicate that the short-period response for the C-5A and L-1011 correspond to Level 1 conditions. However, test results do not completely agree with specification requirements. Although the terrain-following flight phase is not yet used on C-5A fleet aircraft, the in-flight refueling phase has been used with very satisfactory results. Therefore, it appears that, for Flight Phase B, the lower frequency limit should be reduced for altitudes above approximately 20,000 feet.

## Elevator Control Force Gradient

Figure 6 summarizes elevator control force gradient characteristics for the C-5A, C-141A, YC-141B, and the L-1011 for category B at forward and aft center of gravity conditions. This summary shows that the L-1011 complies with the maximum and minimum control force gradient requirements but that the C-5A and C-141A/YC-141B do not. The C-5A at forward c.g. compares favorably with the Level 1 maximum values; however, the gradients at aft c.g. fall below the Level 1 and Level 2 boundaries. The C-141A/YC-141B data slightly exceed the level maximum limit at forward c.g. Pilot comments for the C-141A/YC-141B support the maximum boundary. However, C-5A comments do not support the aft c.g. minimum boundary. The minimum boundary for Level 1 requirements appears to be too high.

## Lateral Directional Damping

Lateral directional damping characteristics for the C-5A, C-141A, YC-141B, and L-1011 are summarized in Figure 7 for the Category B Flight Phase with the yaw damper inoperative. Each of these airplanes comply with the minimum damping (0.08) and frequency (0.40) requirements for Level 1, but as Figure 7 shows, the Level 2 requirement in terms of the minimum product ( $\omega_{nd} \zeta_d$ ) values of 0.05 is not met by the C-5A or the C-141A and YC-141B. Relative to the minimum damping and frequency requirements of 0.02 and 0.40, respectively, the C-5A results show satisfactory compliance. The C-141A and C-141B data comply with the minimum frequency requirements, but the minimum damping requirement is not met.

An evaluation of the C-141A dutch-roll recovery techniques with the yaw damper inoperative was conducted by the Air Force Flight Test Center in February 1977. Results of the tests, presented in Reference 5, show Harper-Cooper rating values ranging from 2.0 to 5.0, using aileron only for recovery, which is the recommended Flight Handbook procedure. Over 100 dutch-roll maneuvers were accomplished during the evaluation, which

# Contrails

consisted of regaining control of the aircraft and returning to a wings-level attitude from bank angles as high as +45 degrees. It should also be noted that evaluating pilots do not rate operation of the C-5A with the stability augmentation system off below the suggested Level 2 guidelines (6.5 Harper-Cooper rating scale). These data strongly indicate that the Level 2 minimum  $\zeta_d \omega_{nd}$  requirement of 0.05 rad/sec is too stringent.

## Roll Mode Time Constant

Figure 8 summarizes roll mode time constant values for the C-5A, C-141A, YC-141B, and L-1011 for Level 1 and Category B Flight Phase. The C-141A and YC-141B data comply with the Level 1 roll-mode time constant requirement of 1.4. However, the C-5A and the L-1011 data show values consistently in excess of the 1.4 requirement.

One of the significant characteristics following the input of rapid full lateral control on the C-5A is that the initial rolling acceleration produces a very noticeable "side kick" or lateral acceleration component in the cockpit and in the troop compartment, since the cockpit and troop compartment are located considerably above the principal roll axis of the airplane. For normal operation, this characteristic can be avoided by initially using slow lateral control input and then increasing the rate of input until the desired airplane response is obtained. In situations which require abrupt full control input, this characteristic will be noticed; however, it will not unduly restrict the use of full control when required.

The purpose of the roll-mode requirement is to describe the shape of the roll rate trace which is essentially defining the average rolling acceleration. The C-5A does not meet the Level 1 requirements. To achieve the Level 1 roll-mode time constant on the C-5A would produce an even more objectionable condition. This problem should be recognized in the roll-mode time constant requirement.

## Sideslip Excursions

Sideslip excursion data for the C-5A, C-141A, YC-141B, and L-1011 are presented in Figure 9 in the form of the ratio of sideslip increment, to the parameter  $K$  versus calibrated airspeed. One-half of the dutch roll period has been used to obtain the  $\Delta\beta$  parameter, since the dutch roll period for each airplane varies from approximately 6 seconds to 11 seconds. This criterion is specified in MIL-F-8785B(ASG). As the data show, neither airplane completely complies with the requirements. The sideslip excursions for the C-5A, C-141A/YC-141B and the L-1011 are not considered excessive. Additionally, the high sideslip excursion angles shown in Figure 9 for the C-5A, the C-141A/YC-141B, and the L-1011 are not considered to be consistent with normal operation due to requirement to hold the aileron command fixed until the bank angle has changed at least 90 degrees. Pilot rating data obtained during the YC-141B flight test program show a value of 2 (Harper-Cooper Rating Scale) with augmentation operative and 4 with the augmentation inoperative. These data indicate that the handling characteristics correspond to Level 1 conditions even though the data fall outside Level 1 requirements at the lower airspeeds.



# Contrails

It should be noted that the L-1011 nearly complies with roll performance requirements, but the sideslip excursions created as a result, as shown herein, exceed allowable limits. The L-1011 sideslip excursions have not prompted any objectionable comments from flight test or airline pilots.

## Roll Performance

C-5A, C-141A, YC-141B and L-1011 Category B test results are presented in Figure 10, along with applicable MIL-F-8785B(ASG) requirements. These data show that only the L-1011 rolling performance compare favorably with the Level 1 requirements.

Although neither the C-5A nor the C-141A/YC-141B comply with the rolling performance requirements, qualitative pilot comments indicate that both airplanes have acceptable rolling performance in the cruise configuration. Results obtained during the YC-141B flight test program show a Harper-Cooper rating of 2.0 with augmentation on and 4.0 with the augmentation off for the cruise configuration. L-1011 rolling performance very nearly meets the requirements; however, abnormal sideslip angles are generated due to spoiler drag when full lateral control is used for an extended period of time.

For the C-5A to meet the Level 1 requirements, the lateral control system would have to be improved to attain a higher bank-angle change in the first second of roll. On an aircraft with a very large rolling moment of inertia, this would be difficult to accomplish. Increasing the initial roll response of the C-5A would further aggravate the very noticeable side kick, or lateral acceleration component, in the cockpit and troop compartment that is experienced during full abrupt control input. The side kick occurs since the cockpit and troop compartment are located considerably above the principal roll axis of the airplane.

## SUMMARY AND CONCLUSION

In spite of the brevity of this paper, it is felt that sufficient data have been assembled from four Class III airplanes to show that significant differences exist between certain sections of MIL-F-8785B(ASG) and presently acceptable handling characteristics criteria. The most significant differences between the specification and the data are those sections dealing with lateral control: roll mode ( $\tau_r$ ), sideslip excursions, and roll control effectiveness. These sections are considered too stringent for Level 1 conditions. The data also indicate that some degree of adjustment in Level 1 requirement boundaries is warranted for the following sections of the specification:

- Phugoid Stability
- Short Period Response
- Control Forces in Maneuvering Flight

The data strongly indicate that the section on lateral directional damping is too restrictive for Level 2 conditions. Specific recommendations for revising the aforementioned sections of MIL-F-8785B(ASG) are not made due to the lack of test results for the various failure states.

# *Contrails*

## REFERENCES

1. Silvers, C.L. and Withers, C. C., "Evaluation of the Flying Qualities Requirements of MIL-F-8785B(ASG) Using the C-5A Airplane," AFFDL-TR-75-3, March 20, 1975.
2. "C-5A Category I/II Engineering Flight Test Flying Qualities Test Results," LGIT19-1-10, 19 June 1970.
3. McCabe, J. H. and Benefield, T. D., "C-141A Category II Stability and Control Test," FTC-TR-66-5, June 1966.
4. "Preliminary Flight Test Report YC-141B Program," AFFTC-TR-77-3, September 1977.
5. Picha, D. G. and Klein, H., "C-141A Dutch Roll Recovery," AFFTC Technical Letter Report, February 1977.

# Contrails

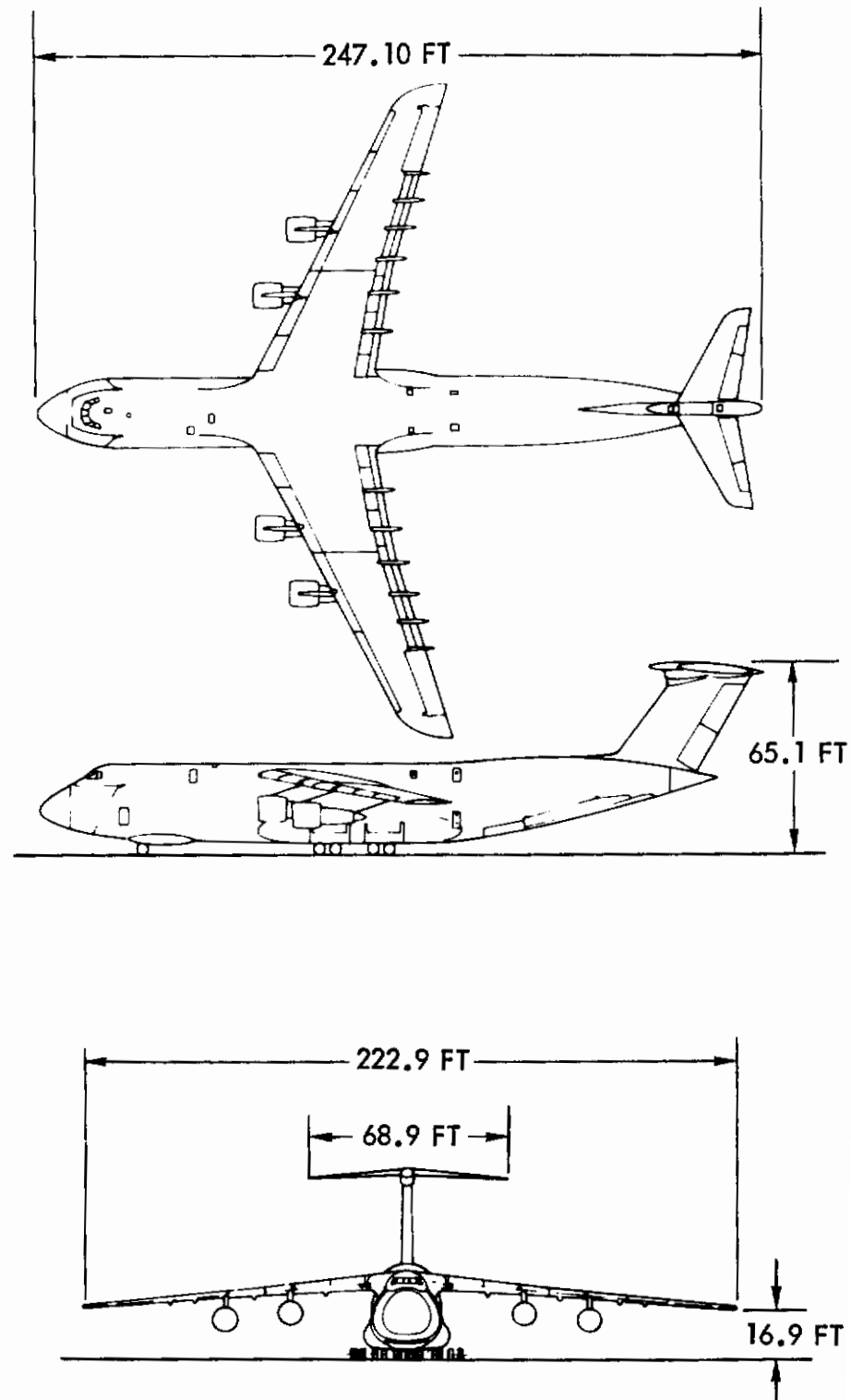

Figure 1. C-5A General Arrangement

# Contrails

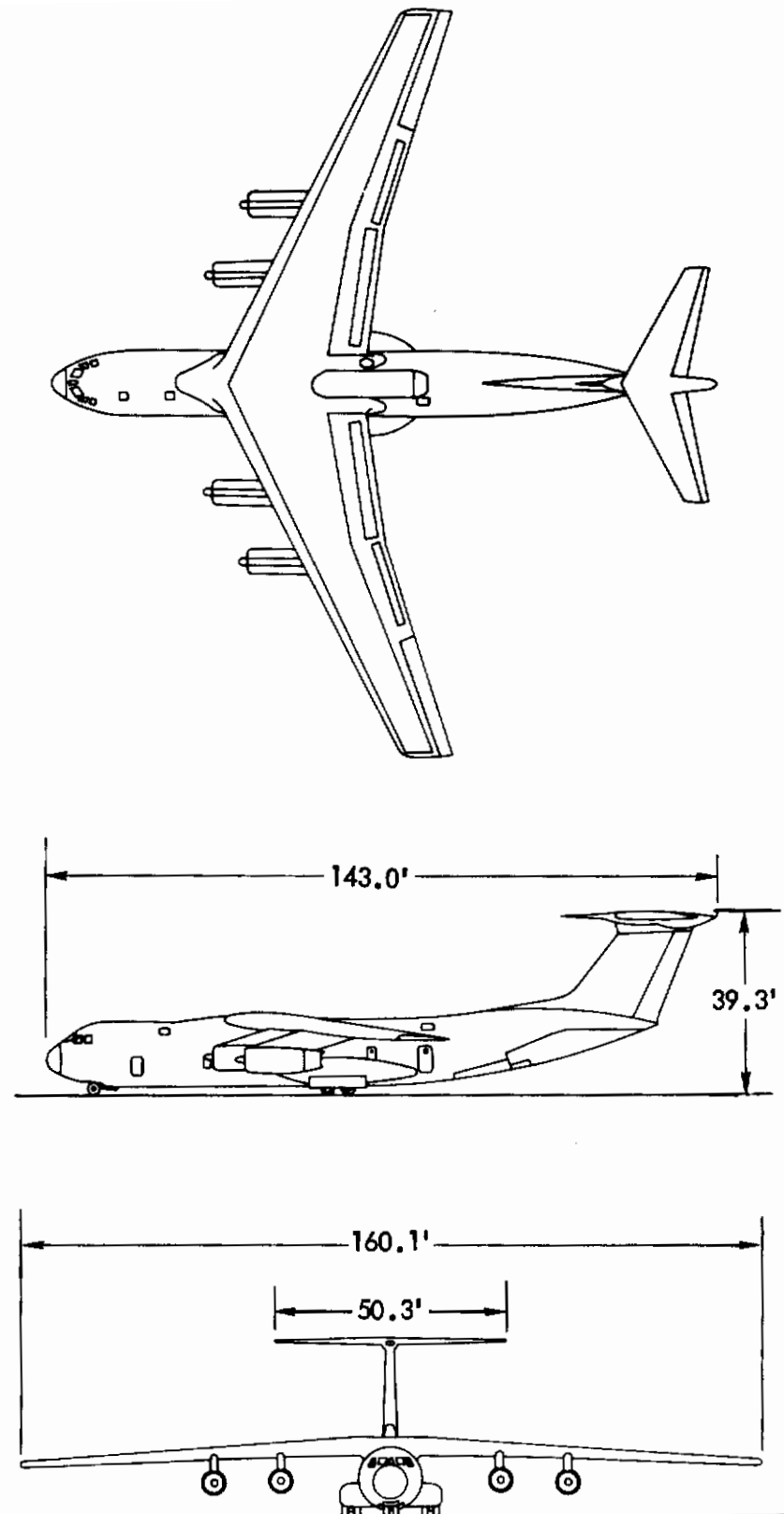

Figure 2. C-141A General Arrangement

# Contrails

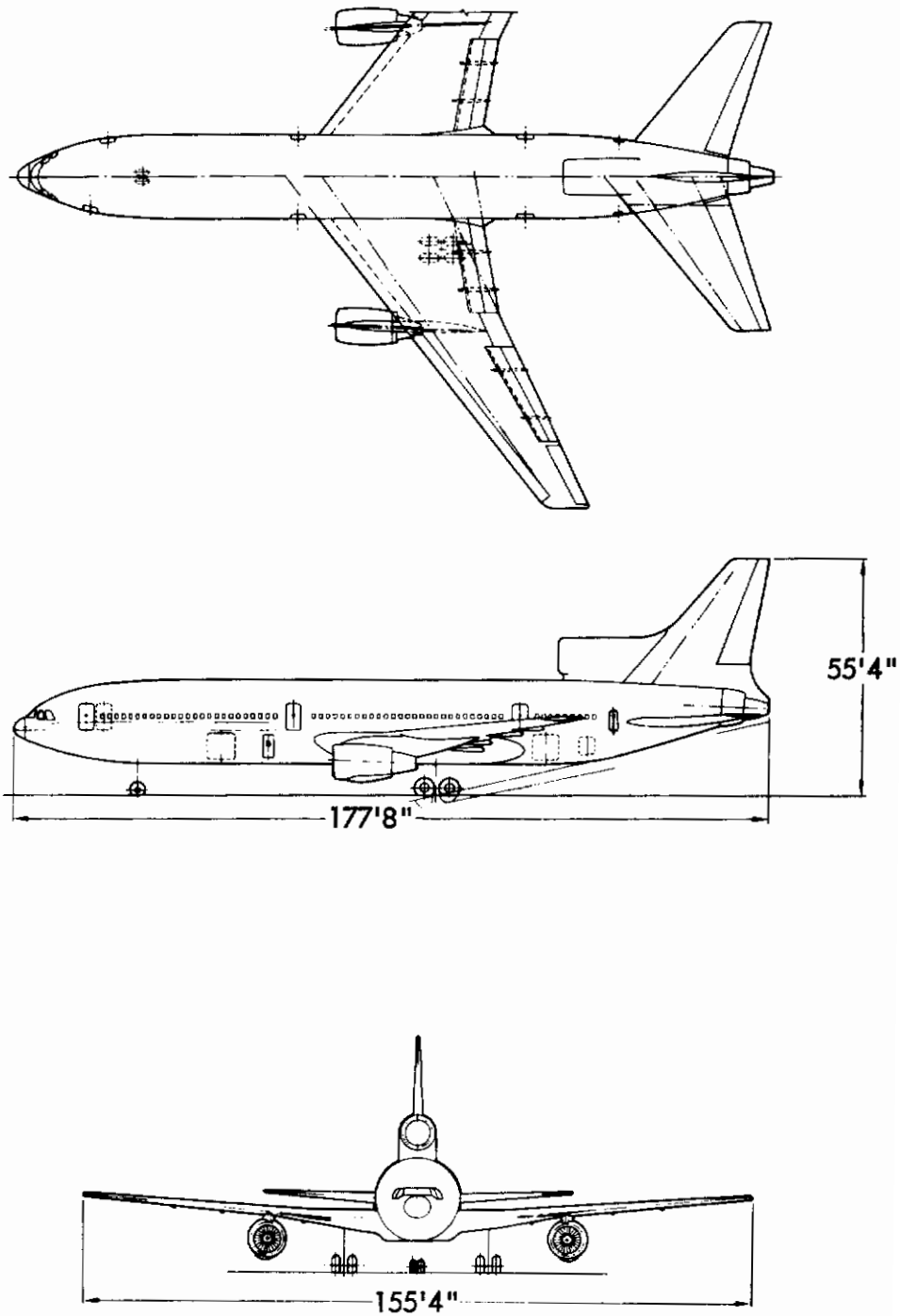
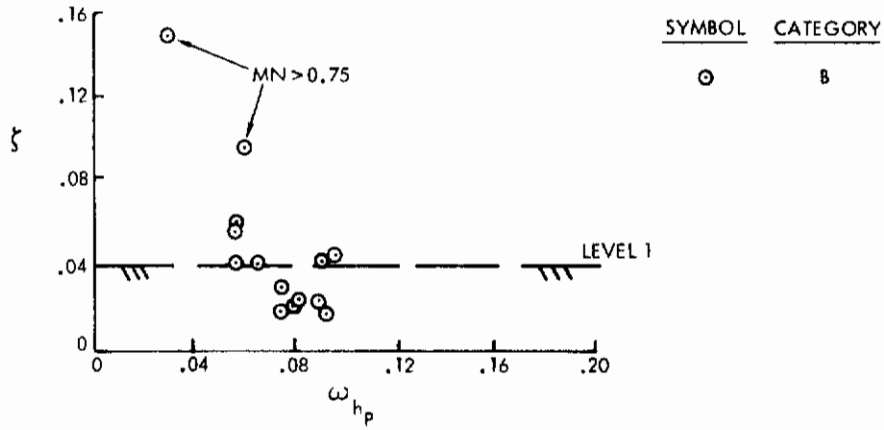

Figure 3. L-1011 General Arrangement

# Contrails

C-5A



C-141A & YC-141B

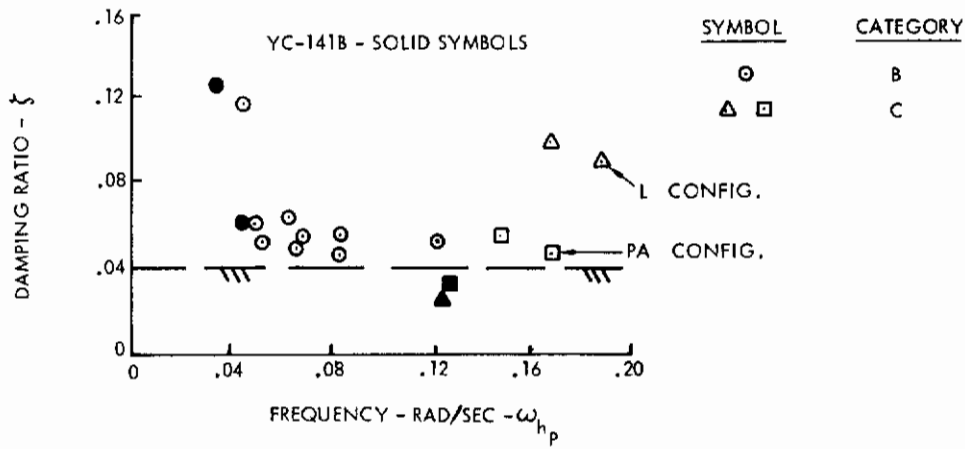

L-1011

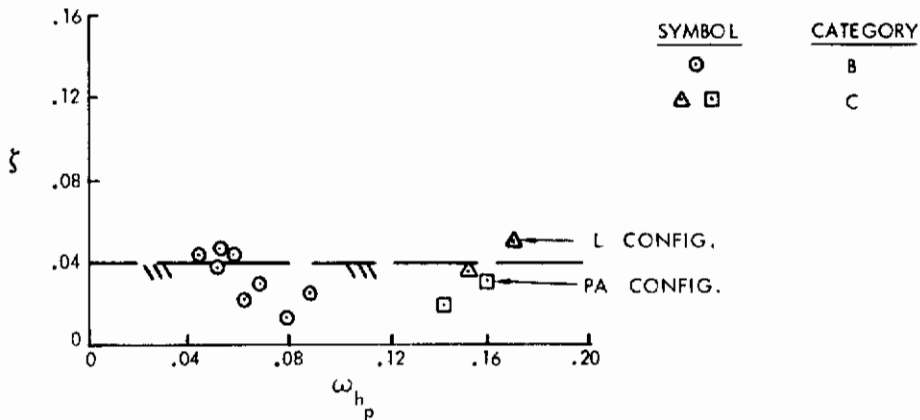
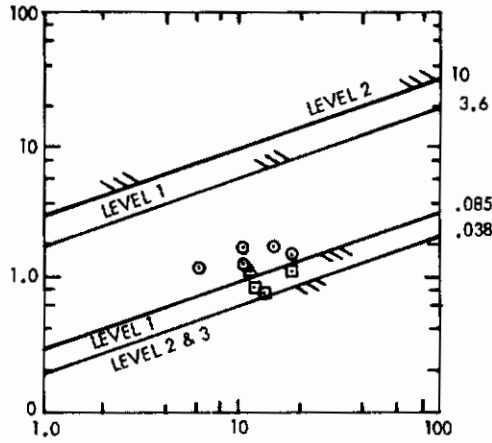

Figure 4. Phugoid Stability

# Contrails

C-5A

CATEGORY B



SYMBOL	ALTITUDE
○	10,000 FT
△	25,000 FT
□	35,000 FT

C-141A & YC-141B

CATEGORY B

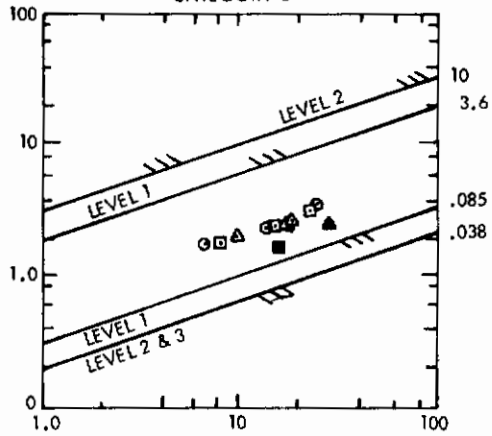

SYMBOL	ALTITUDE
○	5,000 FT
△	25,000 FT
□	40,000 FT

SOLID SYMBOLS ARE  
YC-141B DATA

L-1011

CATEGORY B

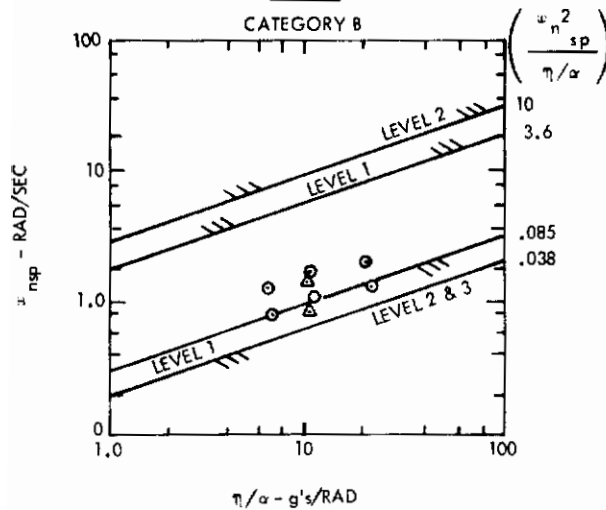

SYMBOL	ALTITUDE
○	20,000 FT
△	35,000 FT

Figure 5. Short Period Response

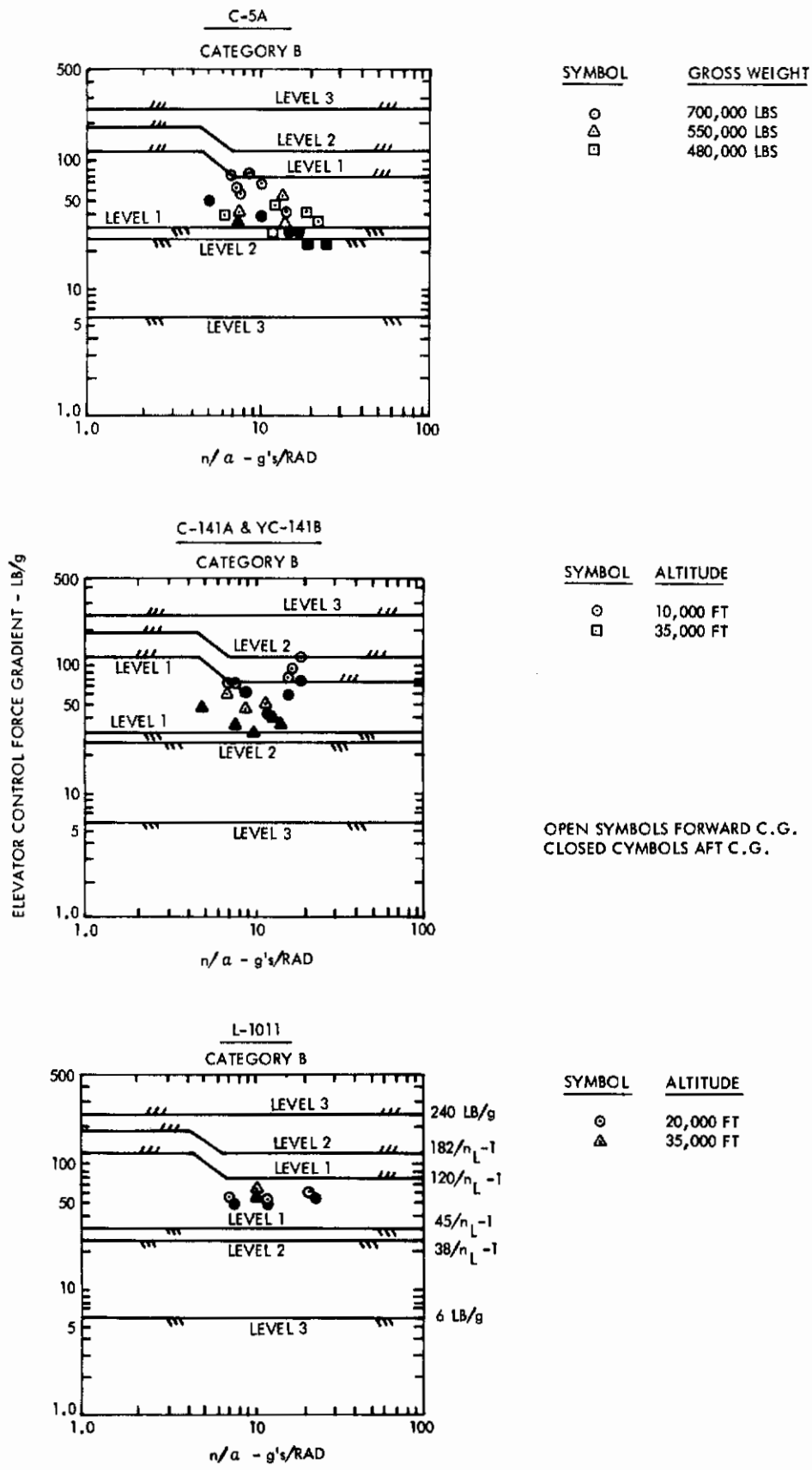
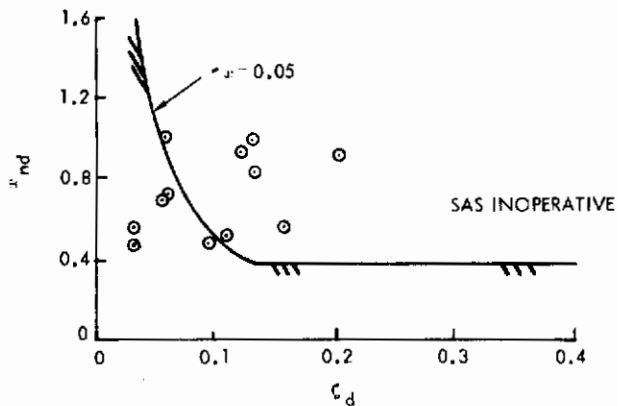

Figure 6. Elevator Control Force Gradient



# Contrails

C-5A  
CATEGORY B  
LEVEL 2



C-141A & YC-141B  
CATEGORY B  
LEVEL 2

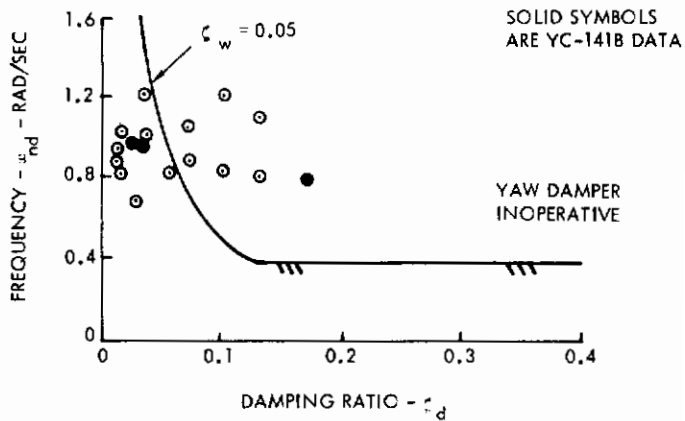

L-1011  
CATEGORY B  
LEVEL 2

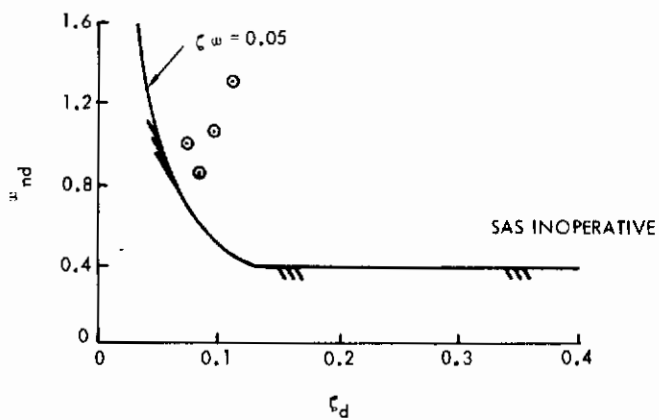
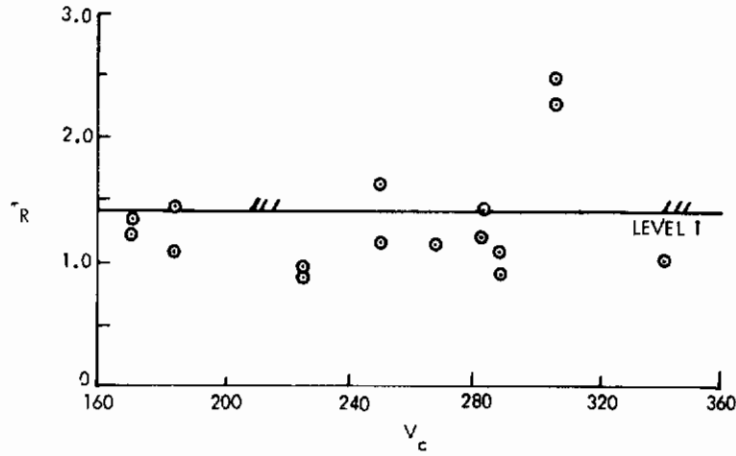

Figure 7. Lateral Directional Damping

# Contrails

C-5A  
CATEGORY B



C-141A & C-141B  
CATEGORY B

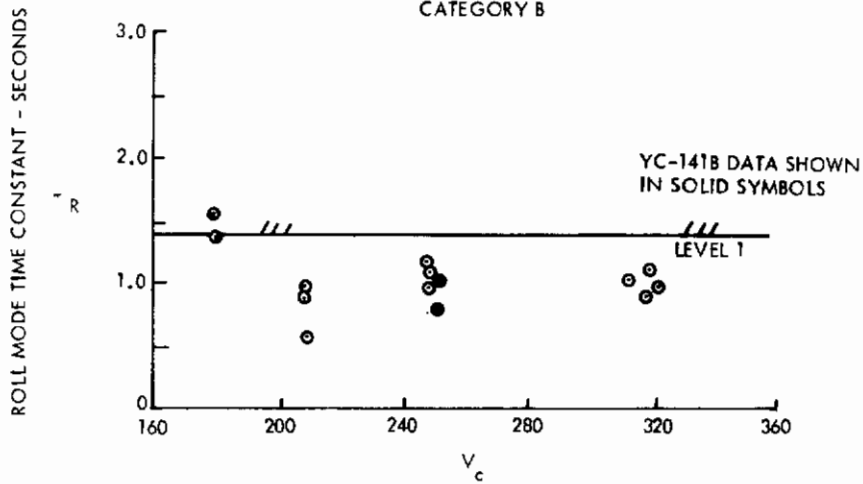

L-1011  
CATEGORY B

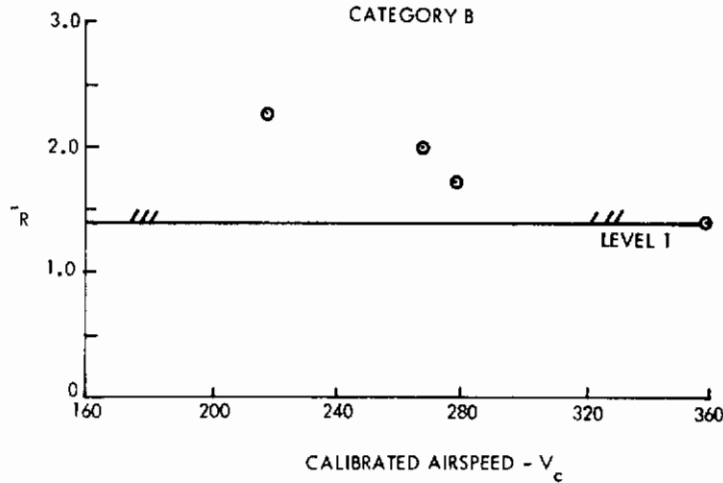

Figure 8. Roll Mode Time Constant

# Contrails

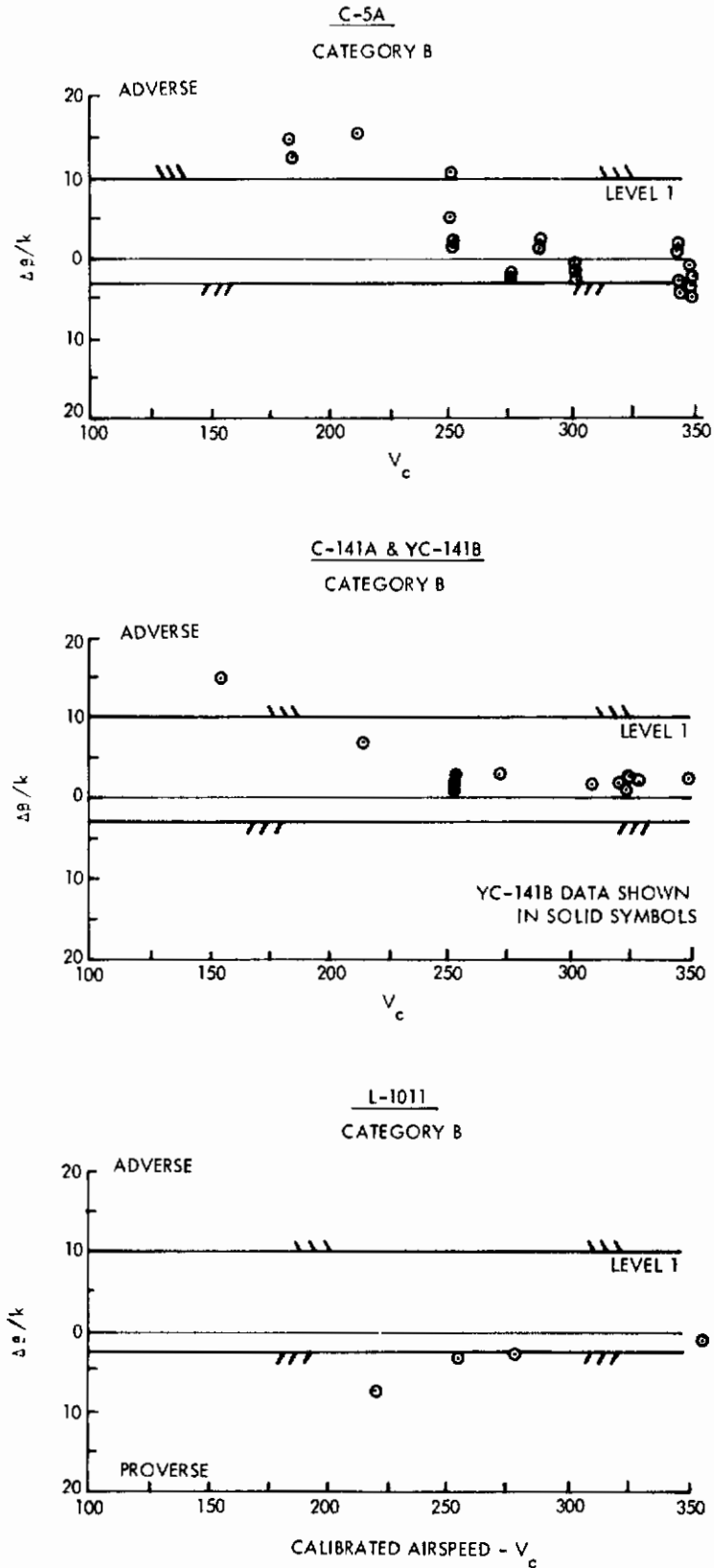

Figure 9. Sideslip Excursions

# Contrails

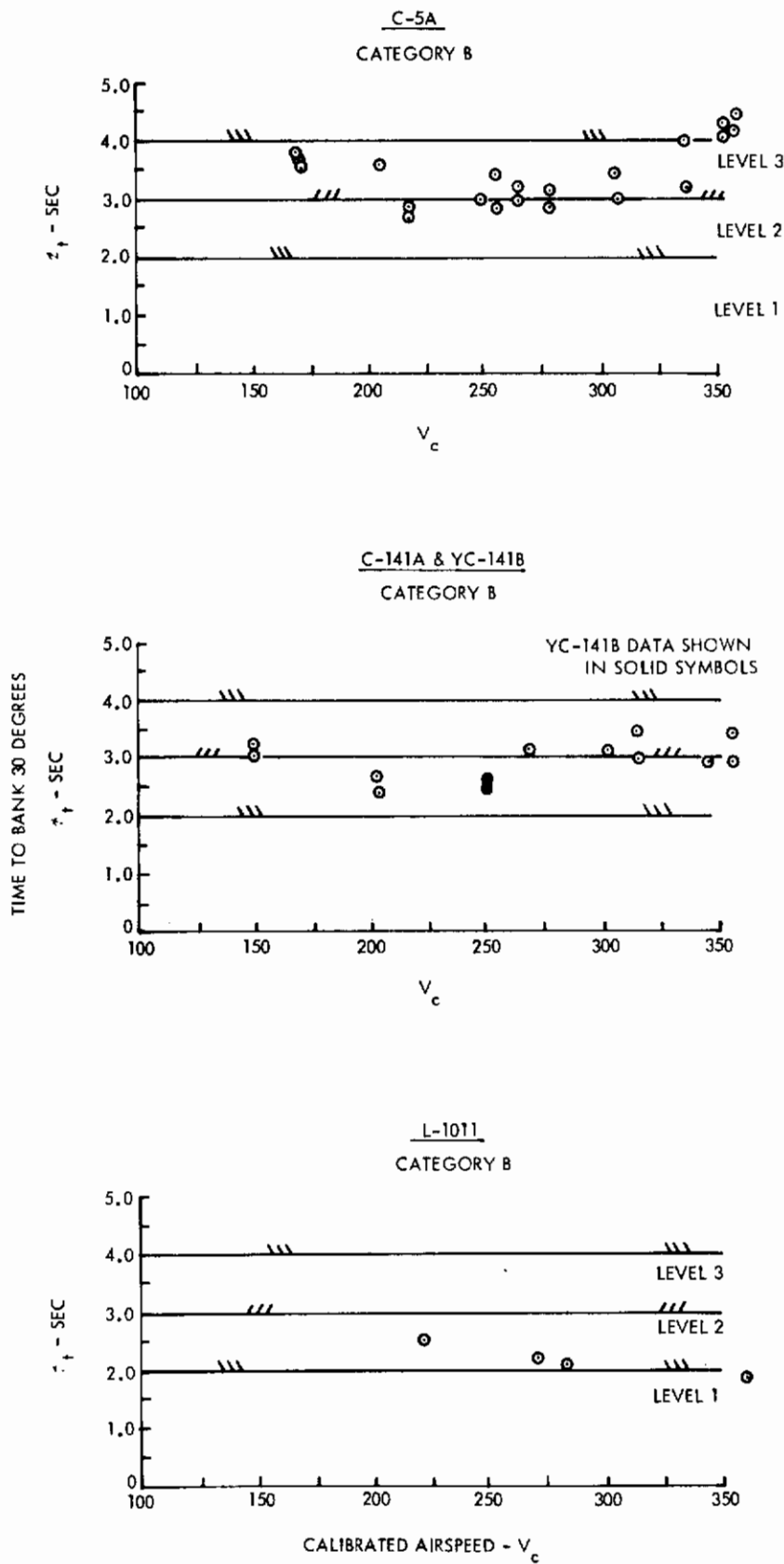

Figure 10. Roll Performance

# Contrails

Bill Rickard, Douglas Aircraft: Douglas feels the  $\pm 60^\circ$  wheel throw is too small. What is Lockheed's position?

Answer: Lockheed has a proposal in to Warner-Robins to reduce the C-141B wheel throw to  $\pm 70^\circ$ . We feel that  $110^\circ$  wheel throw is too large for Class III aircraft.

Comment by Frank Wilson, Lockheed-Georgia on Cliff Wither's paper: None of the four aircraft discussed (C-5A, C-141A, C-141B, or L-1011) were designed to meet requirements of MIL-F-8785B(ASG). The C-5A and C-141A,B were designed to meet MIL-F-8785(ASG).

Bill Rickard, Douglas Aircraft: What is the wheel throw for the L-1011?

Carl Anderson, Lockheed-California: It is  $\pm 85^\circ$ .

# *Contrails*