

WADC TECHNICAL REPORT 54-13

**INVESTIGATION OF THE EFFECT OF RAW MATERIAL PRODUCTION
VARIABLES ON THE PHYSICAL AND CHEMICAL PROPERTIES OF
CARBIDES, NITRIDES, AND BORIDES**

Herman Blumenthal

American Electro Metal Corporation

February 1954

Materials Laboratory

Contract No. AF 33(616)-89

RDO No. 615-17 (A-F)

Wright Air Development Center
Air Research and Development Command
United States Air Force
Wright-Patterson Air Force Base, Ohio

Contrails

FOREWORD

This report was prepared by the American Electro Metal Corporation, under USAF Contract No. AF 33(616)-89. The contract was initiated under Research and Development Order No. 615-17(A-F), "Ceramic Materials", and was administered under the direction of the Materials Laboratory, Directorate of Research, Wright Air Development Center, with Lt W. E. Winter and Lt Norman Hyman acting as project engineers.

WADC TR 54-13

ABSTRACT

The purpose of this project is to investigate the effect of raw material production variables on the physical and chemical properties of carbides, nitrides, and borides. In the investigations carried out so far, this aim has been narrowed down to the study of titanium carbide.

Various titanium carbides, produced commercially by as many different procedures as possible, have been purchased and are being used for this investigation. The various materials have been analyzed spectrographically, chemically and by x-ray diffraction to determine the amounts and kinds of impurities peculiar to the production technique employed. Changes of chemical composition during ball milling, hot pressing and other processing steps leading to the production of solid pieces have been followed by the same analytical techniques as well as metallographic studies.

The question of the effect of the presence of impurities has been approached from two sides, namely (1) by removing and (2) by adding impurities. Some impurities, such as iron, graphite and oxide films, have been partly removed by purification treatments like leaching with acids and flotation. Other impurities, such as TiO , TiN and graphite, have been added to pure TiC .

The effect of various ball milling media on the chemical composition of the milled product has been studied.

In the production of unbonded TiC bars, hot pressing has been used exclusively, while Ni -bonded bars have been produced (1) by hot

pressing and (2) by cold pressing followed by sintering either under a protective atmosphere or in vacuum.

Infiltration experiments have been conducted as an attempt to develop a test procedure for the evaluation of quality of titanium carbide powders.

Hot pressed unbonded bars have been tested for the following properties: maximum density obtainable, ability to infiltrate, and electrical resistivity.

It has been found that the chemical composition of TiC produced by different procedures varies as to combined and free carbon, oxygen and nitrogen content as well as metallic impurities.

The amount and kind of impurities present influence maximum density obtainable by hot pressing unbonded bars, and their ability to infiltrate.

The amount of iron and oxygen picked up during ball milling in a steel mill varies greatly with the ball milling medium.

Ni-bonded bars of high density could be produced so far only by hot pressing. Cold pressing followed by sintering in hydrogen or in vacuum resulted in bars of low density.

The ability of a porous bar to infiltrate depends on its density, impurity content, and particle size of the original powder.

PUBLICATION REVIEW

This report has been reviewed and is approved.

FOR THE COMMANDER:

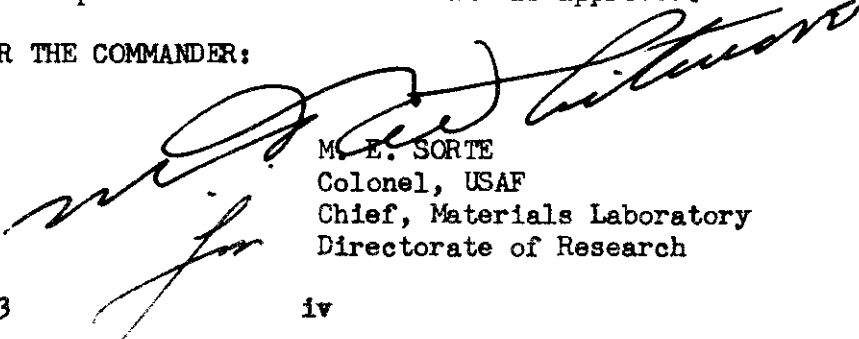
M. E. SORTE
Colonel, USAF
Chief, Materials Laboratory
Directorate of Research

WADC TR 54-13

iv

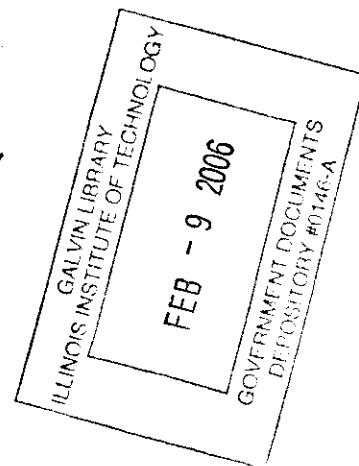

TABLE OF CONTENTS

Section		Page
I	INTRODUCTION.	1
II	MATERIALS	4
III	PRODUCTION OF TITANIUM MONOXIDE	8
IV	FLOTATION	9
V	EFFECT OF BALL MILLING MEDIUM	12
VI	HOT PRESSING.	26
VII	ELECTRICAL RESISTIVITY MEASUREMENTS	34
VIII	INFILTRATION EXPERIMENTS.	36
IX	BINDER STUDY.	51
X	FUTURE WORK	57

Contrails

LIST OF TABLES

Table		Page
1	CHEMICAL COMPOSITION OF COMMERCIAL TITANIUM CARBIDES.	6
2	IRON PICK-UP AND PARTICLE SIZE IN INTERRUPTED AND CONTINUOUS BALL MILLING.	12
3	% IRON PICKED UP DURING BALL MILLING IN AIR AND ARGON	14
4	REDUCTION OF PARTICLE SIZE DURING BALL MILLING IN AIR AND ARGON.	14
5	% IRON PICKED UP DURING BALL MILLING IN LIQUID MEDIA.	18
6	REDUCTION OF PARTICLE SIZE DURING BALL MILLING IN LIQUID MEDIA.	18
7	TOTAL ANALYSES AFTER 64 HOURS BALL MILLING IN DIFFERENT MEDIA	20
8	TOTAL ANALYSES AFTER 64 HOURS BALL MILLING IN DIFFERENT MEDIA AND LEACHING WITH HYDROCHLORIC ACID.	20
9	ANALYSES OF TIC POWDERS PURCHASED FROM KENNAMETAL	21
10	% OXYGEN PICKED UP DURING BALL MILLING IN DIFFERENT MEDIA	22
11	% WC PICKED UP DURING BALL MILLING IN TUNGSTEN CARBIDE MILL	24
12	POWDER PREPARATION, PARTICLE SIZE OF POWDERS AND MAXIMUM DENSITY OF HOT PRESSED BARS.	28
13	ANALYSES OF TIC POWDERS PURCHASED FROM METALLWERK PLANSEE	31
14	INFILTRATION STUDY (KENNAMETAL POWDER).	41
15	INFILTRATION STUDY (NORTON POWDER, TECHNICAL GRADE)	48

Contrails

LIST OF ILLUSTRATIONS

Figure		Page
1	FLOTATION OF A HIGH GRAPHITE CONTAINING MATERIAL.	10
2	PARTICLE SIZE REDUCTION AND IRON PICK-UP DURING BALL MILLING IN AIR AND ARGON.	15
3	PARTICLE SIZE REDUCTION AND IRON PICK-UP DURING BALL MILLING IN OXYGEN CONTAINING LIQUIDS.	16
4	PARTICLE SIZE REDUCTION AND IRON PICK-UP DURING BALL MILLING IN OXYGEN FREE LIQUIDS.	17
5	OXYGEN PICK-UP DURING BALL MILLING IN DIFFERENT MEDIA.. . . .	23
6	SPECIMEN HOLDER FOR ELECTRICAL RESISTIVITY MEASUREMENTS	35
7	INFILTRATED BARS ACCORDING TO MEERSON	37
8	REPORTING OF INFILTRATION RESULTS	39
9	INFILTRATED BARS.	40
10	MICROSTRUCTURE OF INFILTRATED BAR	45
11	MICROSTRUCTURE OF TiC BALL MILLED WITH 10% Ni	52
12	MICROSTRUCTURE OF TiC LEACHED AND TUMBLED WITH 10% Ni	52
13	T. R. STRENGTH VS DENSITY OF "K" POWDERS WITH 10% NICKEL BINDER.	54
14	MICROSTRUCTURE OF TiC (10% TiN) + 20% Ni HOT PRESSED 1700°C	55
15	MICROSTRUCTURE OF TiC (10% TiN) + 20% Ni HOT PRESSED 2000°C	55
16	VACUUM FUSION APPARATUS	58
17	CORROSION TEST IN AIR	59

Contrails

Contrails

I. INTRODUCTION

The aim of this project is to investigate the effect of raw material production variables on the physical and chemical properties of carbides, nitrides, and borides. As the number of variables to be checked is very large, it is necessary to restrict this study to one material only. The material selected is titanium carbide.

Titanium carbide is the base material for a number of cermets which have aroused considerable interest for high temperature applications, such as parts in jet engines. The properties of titanium carbide with and without binders have been measured frequently in the laboratory, and values have been obtained which should make materials based on TiC very useful for such applications. However, it was found that considerable fluctuations occurred between the properties of pieces produced in identical ways from the same raw material batch, as well as from raw materials from different producers. Ordinary chemical analyses for purity and carbon content of the carbide have not revealed significant differences. The reasons for lack of reproducibility must, therefore, lie in small amounts of impurities, or in production differences which result in powders of different shapes and surface conditions. It is well known that even in the production of steel cutting grades of carbide tools, the titanium carbide raw materials supplied by different producers do not behave in exactly the same manner. The production procedure of one manufacturer seems to be best for one particular raw material, which, on the other hand, is not usable in the process of another manufacturer.

Contrails

The purpose of this project is to determine the important impurities and to find out in which manufacturing process they can be tolerated, or whether it is possible to eliminate them or compensate for their harmful influence by the addition of another ingredient. It would be very desirable to develop a testing method for titanium carbide powder which would make it possible — beyond the result of chemical analysis — to choose a raw material for suitability in a certain production procedure and for certain applications.

A large number of titanium carbide grades produced by different processes are commercially available from various manufacturers. They have been procured for this investigation and are being tested by detailed chemical analyses, x-ray investigation methods, and for their behavior during the manufacturing process into a finished part. So far the manufacture of titanium carbide has not been considered. Parts, both with and without binder, are to be produced from commercially available materials.

It is possible that an impurity which is harmful for pure titanium carbide becomes tolerable if a binder, such as nickel, is added. It is necessary to determine not only the amounts of the various impurities, especially oxygen and nitrogen, but also the form in which they appear. They might be either in solid solution throughout the bulk of the titanium carbide particles or as surface films around the individual grains. The degree to which these various impurities influence the physical properties is being investigated.

The impurities of the raw material are, however, not necessarily also the impurities of the finished product. During the various processing steps, forms and amounts of impurities, especially oxygen and

Contrails

nitrogen, might change considerably, and chemical analyses and tests have to be made to follow these changes. It is not predictable to what extent the addition of a binder will influence chemical composition. All this means that a large number of chemical analyses are necessary.

Other factors which might be influenced by the production procedures are changes in grain size, and diffusion processes which occur during sintering. The amounts of free and combined carbon may change, and it is possible that a binder will react with titanium carbide to change the phase relationship equilibrium.

Ball milling, which is necessary to reduce titanium carbide to the desired particle size, and which is standard procedure to incorporate binder materials, has an oxidizing effect on the carbide raw material. It is necessary to investigate the correlation between the reduction in particle size and the amount of impurities gained during various ball milling procedures, changing times and ball milling media. The picked-up oxygen might again be either in the form of an oxide film or in solution with carbide.

Experiments with pure titanium carbide without the addition of a binder should serve to establish differences between the raw materials secured from various suppliers. The ability to infiltrate porous bars, pressed from these powders, with liquid cobalt or nickel is considered a means to predict the behavior of various powders during production of finished parts.

Contrails

II. MATERIALS

Titanium carbide is produced commercially from titanium dioxide (TiO_2) and carbon. The raw materials are well mixed and then either melted or heated to a temperature at which reaction takes place in the solid state. A protective atmosphere is essential in either case. The reaction proceeds according to the equation $TiO_2 + 3 C \longrightarrow TiC + 2 CO$.

For experimental purposes TiC has also been produced by reacting titanium metal or titanium hydride with carbon, by fused salt electrolysis, by thermal decomposition of titanium tetrachloride on a hot carbon filament, and by precipitation from a gaseous mixture of hydrogen, titanium tetrachloride, and toluene. According to its formula, TiC, titanium carbide has the stoichiometric composition of 79.97% Ti and 20.03% C. The actual amount of carbon combined with titanium in the commercial products, however, is between 17% and 19.5%, and there is always a certain amount of free carbon present ranging from 0.5% to 3.0%, which, even with repeated heating at high temperature, does not combine with titanium. It is considered to be one of the aims of this project to investigate, if there are really voids in the lattice structure of a low combined carbon containing TiC, or if some places which should be occupied by carbon atoms are actually occupied by nitrogen or oxygen, making the product a solid solution of TiC, TiN and TiO. It is known that production variables, such as starting materials, heating time and cycle, temperature, production procedures, etc. vary the amount of combined carbon in titanium carbide.

Commercially produced titanium carbide was purchased from five different sources and analyzed chemically, spectrographically and by x-ray diffraction. Chemical analyses were done in our own laboratory, spectrographic analyses by Lucius Pitkin in New York, and x-ray diffraction

Contrails

studies were carried out by Dr. B. Post, Polytechnic Institute of Brooklyn. Oxygen determinations were made by National Research Corporation, Cambridge, Massachusetts, and, as a courtesy, by the Naval Research Laboratory, Washington, D. C.

Table 1 shows the results of chemical and spectrographic analyses of the various materials.

Following are the production procedures, as far as they are known to us, used by the different manufacturers:

1. The Titanium Alloy Manufacturing Division of National Lead Company melts the raw materials in an electric arc furnace, very probably under a protective atmosphere. The product is sold in the form of lumps. Crushing or milling of these lumps to the desired size causes a considerable iron pick-up. Other impurities are introduced with the raw materials.

The x-ray pattern shows a broadening of the TiC lines indicating inhomogeneity. The lattice parameter is higher than usual, $a_0 = 4.339 \text{ \AA}$, probably due to the presence of Zr, W, and V in the TiC lattice. Chemical analysis shows the presence of these metals (Table 1).

2. Metallwerk Plansee, Reutte-Tirol, reacts the raw materials together in the solid state using a vertical carbon tube furnace and no other protective atmosphere than the carbon monoxide formed during the reaction. This is probably the reason for the relatively high oxygen content.

The x-ray pattern shows a perfect TiC lattice structure.

3. Kennametal uses a bath of molten iron as a menstruum in which the reduction of TiO_2 with carbon takes place.¹⁾ The molten bath protects

1) U.S. Patent 2,515,463

TABLE 1
CHEMICAL COMPOSITION OF COMMERCIAL TITANIUM CARBIDES

Producer	Titanium Alloy	Metallwerk Plansee	Kennametal Inc.	Morton Co.		Metro- Cutanit
				Pure Grade	Technical Grade	
Code	T-2	R-4	K-1	N-1	N-2	MC-1
Ti	73.8	79.1	79.9	80.0	66.2	79.0
C comb	17.9	18.7	19.45	19.15	14.5	19.0
C free	2.72	0.63	0.25	0.25	12.0	0.54
Fe	2.12	0.10	0.03	*0.001	0.23	0.11
Zr	1.87	*0.01		*0.01	1.14	
Cr	0.06	*0.04			0.28	
V	0.4				0.35	2)
W	0.56	0.40				
Cu	*0.001	*0.005	*0.001		*0.001	*0.01
Mn		*0.005				
Mg		*0.002		*0.001	0.03	
Si	0.19	0.19		*0.1	0.14	
Al		*0.01		*0.01	0.14	
Pb		*0.04				
Sn		*0.04				
O ₂	1)	1.05	0.17		1)	1)
N ₂	0.44	0.57	0.21		0.50	0.67
Cl			0.013			
Total	100.05	100.88	100.02	100.27	95.51	99.33
<u>C comb</u>						
Ti + C comb		19.1	19.6	19.3	18.0	19.4

1) Not yet available
2) Approximate values

* Less than

Contrails

the reaction product and probably dissolves impurities. After the reaction is complete and the bath frozen and cooled, it is broken up and the TiC particles are freed by an acid leach. The product is practically free from all metallic impurities and has the highest amount of combined carbon of all investigated materials.

Its x-ray pattern reveals a well defined TiC structure; precision measurement indicates a lattice parameter of $a_0 = 4.326 \text{ \AA}$.

4. Norton Company's production procedure is not known to us. The company only reveals that the material is produced by reaction of the raw materials in an electric furnace. The technical grade material has an extremely high free carbon content and a considerable amount of metallic impurities.
5. The titanium carbide powder received from Metro-Cutanit, London, is produced by a solid state reaction in vacuum. As the chemical analysis shows, it is almost free from metallic impurities which are probably volatilized in vacuum. Its combined carbon content is high and the x-ray analysis reveals an essentially pure TiC, lattice parameter $a_0 = 4.328 \text{ \AA}$, with some non-crystalline "background" material.

From all of these materials only the Norton Company's product has a particle size fine enough to be used in the as-received condition. The particle size of all the other materials have to be reduced before compacting.

III. PRODUCTION OF TITANIUM MONOXIDE

One series of this investigation is concerned with the effect of the presence of TiO on the properties of TiC . Difficulties have been encountered in securing TiO from a commercial source, only 100 grams could be located and purchased. For this reason TiO used in this investigation is produced by heating a stoichiometric mixture of TiO_2 and TiH_2 for 3 hours at $1500^{\circ} C.$ in a dry hydrogen atmosphere. The product is fairly uniform as shown by its x-ray pattern. Only a very slight amount of titanium dioxide is present. Chemical analysis reveals the presence of a considerable amount of nitrogen and carbon; oxygen analysis has not been made. It is assumed, that nitrogen and carbon are present only in the form of titanium carbide and nitride and that the remaining titanium is combined with oxygen as TiO . Under these assumptions the product is 63.5% TiO , 10.5% TiC , and 17.3% TiN . The commercial material contains 83.3% TiO , 7.1% TiC , and 6.2% TiN . For the experiments conducted so far the former TiO was used as the addition agent.

IV. FLOTATION

High free carbon containing carbide powders of proper particle size can be freed of most of the excess carbon by a flotation procedure.¹⁾ The process consists of mixing material of fine particle size with water in a flotation cell, and the use of pine oil or a similar reagent as a frothing agent. The graphite is carried off in the "overflow", while the bulk of the purified carbide stays behind in the flotation cell as "tailings".

The process has been carried out successfully with the Norton powder N42, which is fine enough to be used as received, and the Titanium Alloy powder T-2, which is crushed to -100 mesh before flotation. The initial graphite content of Titanium Alloy's powder can be brought down in one flotation step from 2.7% to 0.2%. The high free carbon content of the Norton material has been similarly reduced in one step from 12% to 6.53%, in the second step to 2.06%, and in the third step to 0.37%. In one particular flotation experiment, 1000 grams of this powder in the as-received condition were submitted to the following procedure:

The overflow and tailings of the first flotation were both submitted to a second flotation. This resulted in four fractions, the amounts and free carbon content of which are shown in Figure 1. (See next page).

About one-third of the original material now had a very low free carbon analysis. A repeat treatment of the other fractions would result in a higher yield of low carbon material. The analysis of the material purified in this way revealed that not only free carbon was lost, but that the combined carbon had increased to a much higher degree than titanium. In

1) British Patent 651,034

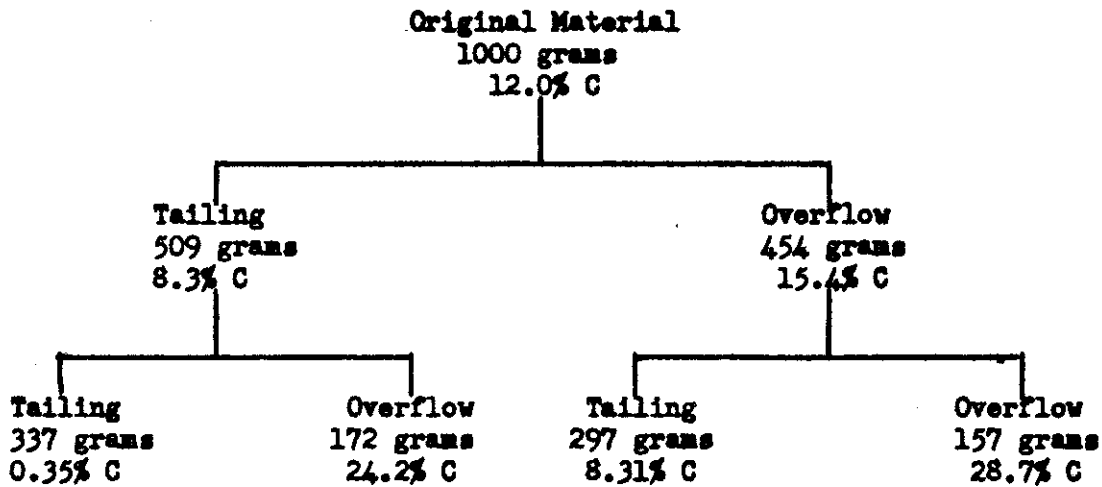

FLOTATION OF A HIGH GRAPHITE CONTAINING MATERIAL

FIG. 1

other words, some titanium was also lost and, therefore, the C/Ti + C ratio increased from 18.0 to 19.3. The total analysis, which added up to 95.6 as received, increased to 97.23. It is believed that this can be explained by the removal of titanium oxide. This assumption will be verified later by determination of the oxygen content of the as-received and as-purified materials.

A hydrochloric acid leach of the flotation purified Titanium Alloy powder removes only iron, picked up during crushing and ball milling. It must be concluded that the main impurities, zirconium, vanadium, tungsten and silicon, are present in the form of carbides.

Some remarks might be added to the flotation procedure as described in the above-mentioned patent. Floatability is a surface phenomenon. The nature of the film on the outside of the particle is the controlling factor. The selective filming of grains in an aggregate of various

Contrails

materials by a specific reagent promotes floatability of these grains in preference to the others. Flotation reagents are called "collectors". The froth is produced by a second reagent, the "frother", and often a third is used, a "depresser", which assists in the selective separation of one solid from another by inhibiting its flotation. The procedure as described in the above-mentioned patent uses a frother only, no collector or depresser. Due to this omission, the procedure has two shortcomings: the first is that a large amount of titanium carbide is carried over in the overflow, and the second, an even more serious one, is that the end of the flotation cannot be observed. The process has to be interrupted after an arbitrarily chosen time, and the amount of tailing or overflow cannot be predicted. It should be possible to improve this situation by the addition of one or two more reagents which would increase the selectivity of the process.

TABLE 3

IRON PICKED UP DURING BALL MILLING IN AIR AND ARGON

<u>Time (Hours)</u>	<u>Air</u>	<u>Argon</u>
0	0.06	0.06
1	0.28	0.25
2	0.41	0.31
5	0.70	0.62
8	1.07	0.83
16	1.42	1.20
32	1.62	1.52
64	1.78	1.80

TABLE 4

REDUCTION OF PARTICLE SIZE DURING BALL MILLING IN AIR AND ARGON

(Average Particle Size in Microns)

<u>Time (Hours)</u>	<u>Air</u>	<u>Argon</u>
0	32	32
1	22	22
2	14.3	16
3	11.0	11.6
4	9.0	9.0
5	6.8	7.6
6	5.7	6.5
7	4.9	6.0
8	4.2	5.1
10	3.7	4.3
13	2.9	3.4
16	2.6	2.9
32	1.7	2.1
64	1.4	1.4

Contrails

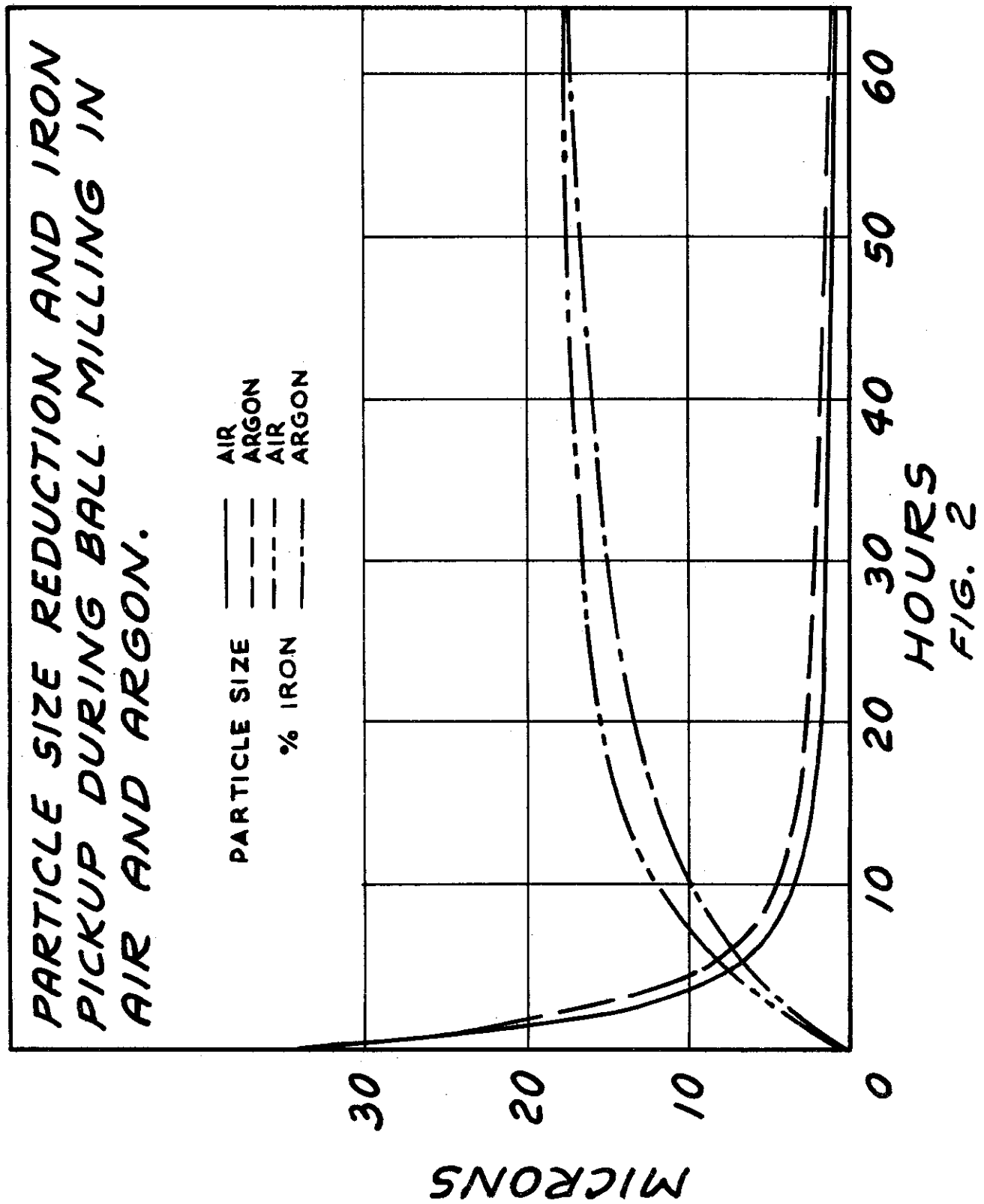

Contrails

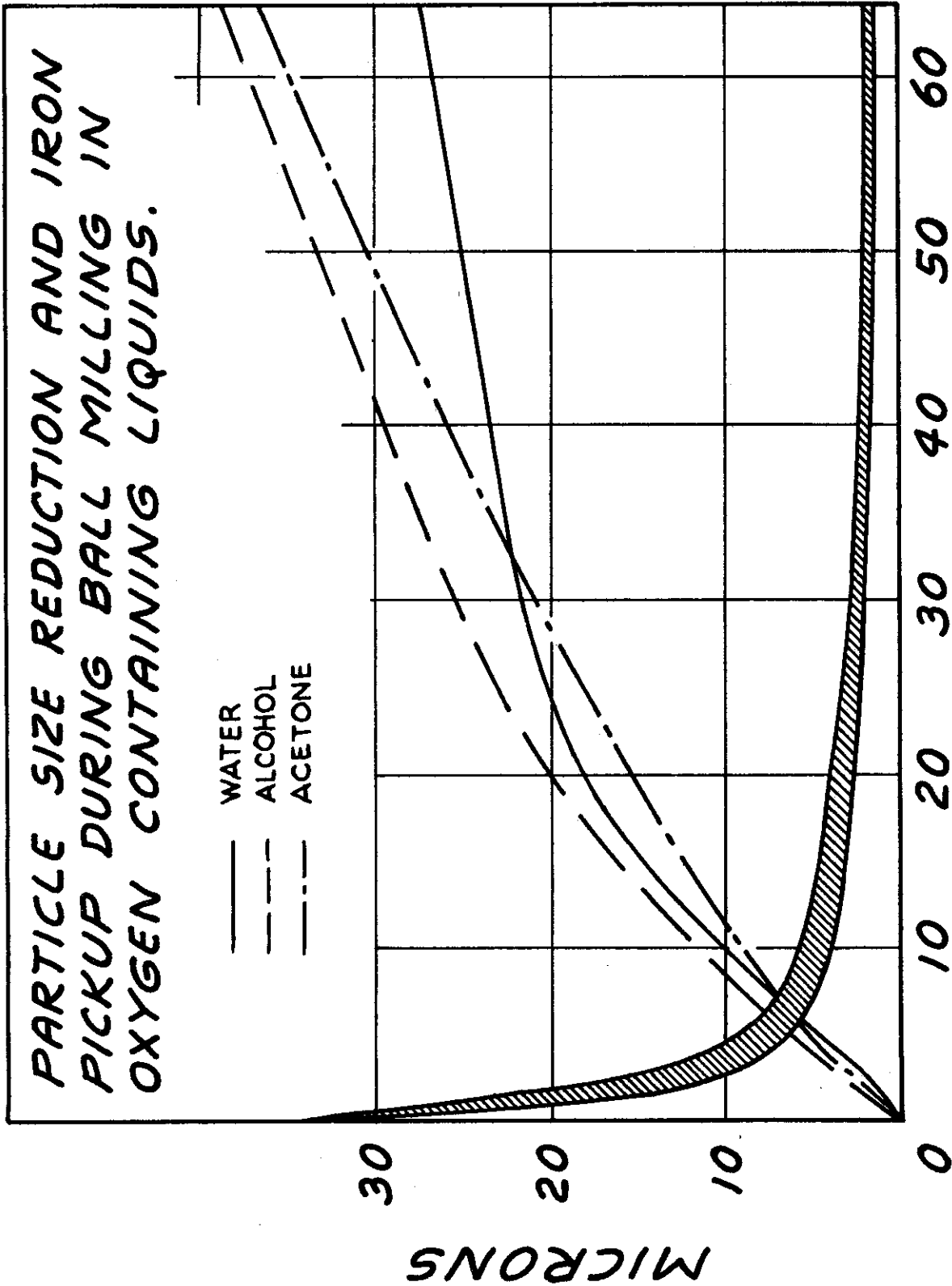

HOURS
FIG. 3

Contrails

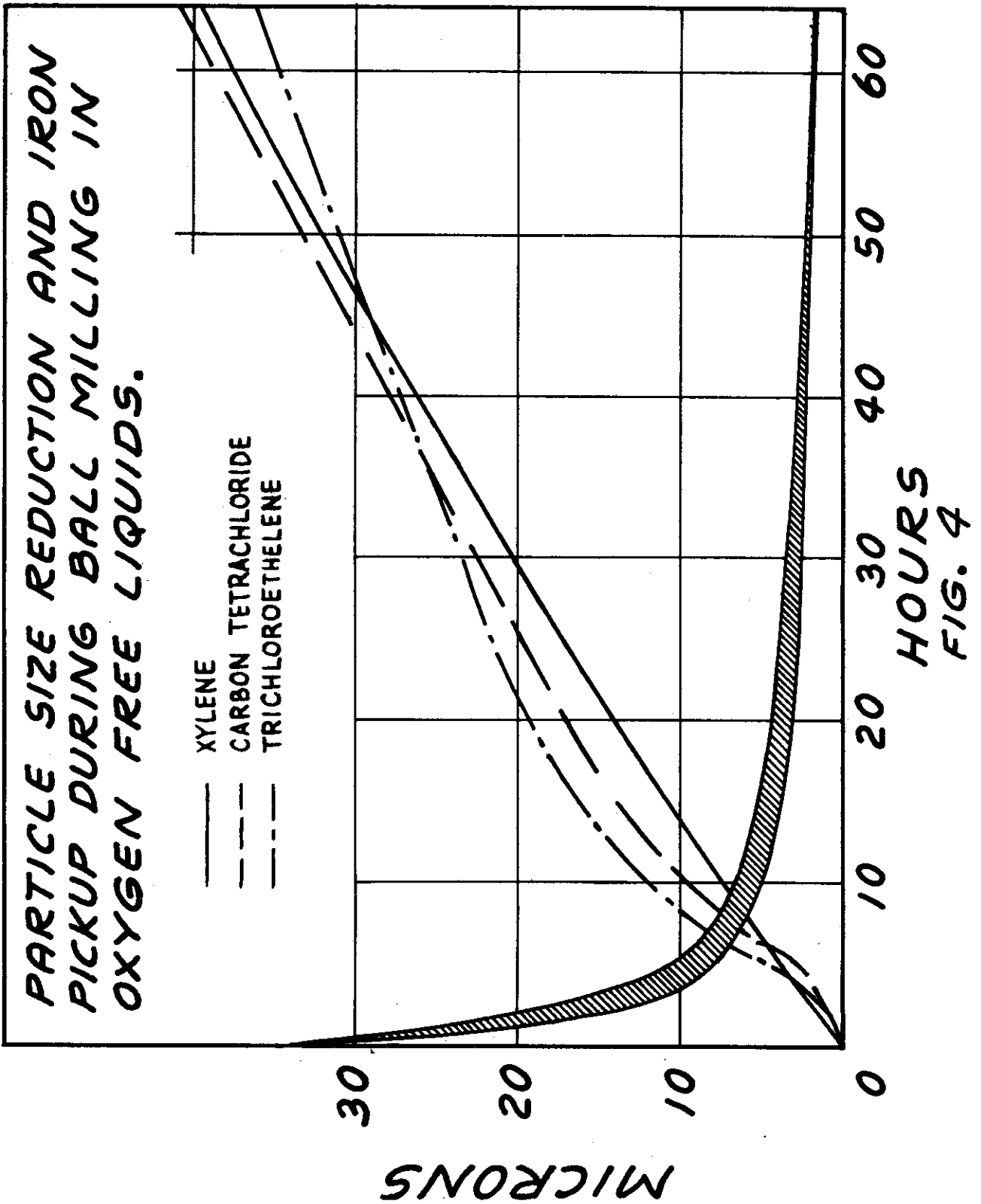

Contrails

TABLE 5

% IRON PICKED UP DURING BALL MILLING IN LIQUID MEDIA

<u>Time</u> <u>(Hours)</u>	<u>H₂O</u>	<u>C₂H₅OH</u>	<u>CH₃COCH₃</u>	<u>Xylene</u>	<u>CCl₄</u>	<u>C₂HCl₃</u>
0	0.06	0.06	0.06	0.06	0.06	0.06
1	0.47	0.40	0.32	0.38	0.28	0.32
2	0.89	1.27	0.86	0.80	0.63	0.51
5	2.06	2.51	2.21	1.52	1.36	2.40
8	3.88	4.03	2.54	2.81	3.73	3.42
16	7.87	9.81	5.69	5.56	7.40	8.75
32	11.0	12.5	11.0	10.5	10.4	11.5
64	13.6	19.2	18.25	19.7	22.0	18.15

TABLE 6

REDUCTION OF PARTICLE SIZE DURING BALL MILLING IN LIQUID MEDIA

<u>Time</u> <u>(Hours)</u>	<u>H₂O</u>	<u>C₂H₅OH</u>	<u>CH₃COCH₃</u>	<u>Xylene</u>	<u>CCl₄</u>	<u>C₂HCl₃</u>
0	32	32	32	32	32	32
1	21.5	18.6	27.8	19.6	24	25.4
2	15.0	11.6	11.3	12.9	18	18.7
3	11.7	10.3	10.5	11.4	12.8	13.8
4	8.8	7.9	6.4	8.5	11.2	9.9
5	8.0	7.3	6.1	8.3	—	8.1
6	6.8	7.0	5.8	7.4	8.3	8.0
7	6.2	6.7	5.2	6.9	7.8	7.7
8	5.1	—	4.4	6.2	6.8	7.5
10	4.4	6.0	4.3	4.7	6.2	5.1
13	3.5	4.9	4.2	4.4	5.2	3.9
16	3.1	—	4.0	4.1	3.6	3.6
32	2.5	2.2	2.4	2.6	3.1	2.5
64	2.1	1.6	1.5	1.8	1.8	1.7

Contrails

this coating becomes denser and more protective with time. Ball milling in a liquid medium destroys this coating and the pick-up of iron increases. There is, however, also an individual influence of the various liquids on the iron pick-up, which is probably due to chemical reactions of the liquid alone, or in connection with the air, on mill and balls. The influence of air plus liquid is most obvious in ball milling with water, where the pick-up rate decreases considerably when the ball mill stays closed for 16 and 32 hours. The admission of air into the ball mill seems not to affect the iron pick-up in carbon tetrachloride where a straight line relationship exists between iron pick-up and ball milling time. The other liquids fall in between these extremes, but are somewhat nearer to carbon tetrachloride than to water.

The total analyses of titanium carbide ball milled for 64 hours in various media are given in Table 7. Table 8 shows the analyses of two of the same powders after leaching with hydrochloric acid. Only these two powders have been leached so far. Most oxygen determinations in Table 7 and all in Table 8 are still missing. Some of the following conclusions are, therefore, to be considered as tentative.

Chlorine is picked up during ball milling in carbon tetrachloride and trichloroethylene. The chlorine showing in the analysis of the powder ball milled in acetone has been extracted from the neoprene gasket used in the ball mill. It is removed completely after leaching with hydrochloric acid. An increase in free carbon content, which varies between 25 to 50%, occurs after ball milling in organic liquids. This increase amounts to 100% after ball milling in carbon tetrachloride and trichloroethylene. These media obviously decompose while reacting with balls and mill. The increase in free carbon after ball milling in water is unexplained.

Contrails

TABLE 7

TOTAL ANALYSES AFTER 64 HOURS BALL MILLING IN DIFFERENT MEDIA

	<u>Air</u>	<u>Argon*</u>	<u>H₂O</u>	<u>CCl₄</u>	<u>CH₃COCH₃</u>	<u>C₂HCl₃</u>	<u>C₂H₅OH</u>	<u>Xylene</u>
Ti	77.2	78.2	66.3	58.8	62.9	60.9	61.3	62.4
C comb	19.0	19.1	16.3	14.0	15.15	14.6	15.1	15.1
C free	0.20	0.06	0.34	0.43	0.25	0.40	0.28	0.31
Fe	1.78	1.80	13.5	22.0	18.3	18.2	19.2	19.7
N ₂	0.17	0.16	0.11	0.14	0.10	0.14	0.16	0.15
O ₂			1.64	2.88				
Cl	0.02		0.01	0.52	0.21	0.47	0.02	0.04
Total			98.20	98.77				
<u>C comb</u>	19.7	19.7	19.7	19.3	19.4	19.3	19.8	19.4
<u>Ti + C comb</u>								

* Powder K-3 was used for this experiment.
 Powder K-2 was used for all other experiments (see Table 9).

TABLE 8

TOTAL ANALYSES AFTER 64 HOURS BALL MILLING IN DIFFERENT MEDIA
 AND LEACHING WITH HYDROCHLORIC ACID

	<u>H₂O</u>	<u>CCl₄</u>	<u>As Rec'd.</u>
Ti	79.3	79.6	79.7
C comb	19.3	19.8	19.4
C free	0.39	0.37	0.21
Fe	0.14	0.24	0.06
N ₂	0.24	0.18	0.15
O ₂			0.01
Cl	0.02	0.01	0.01
Total	99.39	100.20	99.54
<u>C comb</u>	19.6	19.9	19.6
<u>Ti + C comb</u>			

TABLE 9

ANALYSES OF TIC POWDERS PURCHASED FROM KENNAMETAL

	<u>K-1</u>	<u>K-2</u>	<u>K-3</u>
Ti	79.9	79.7	80.0
C _{comb}	19.45	19.4	19.6
C _{free}	0.25	0.21	0.04
Fe	0.03	0.06	0.13
N ₂	0.21	0.15	0.20
O ₂	0.17	0.014	0.021
Cl	0.013	0.009	0.10
Total	100.02	99.54	100.09
$\frac{C}{Ti + C}$	19.6	19.6	19.7

Contrails

More data will be available after leaching of all ball milled powders with hydrochloric acid and completion of chemical analyses.

TABLE 10

% OXYGEN PICKED UP DURING BALL MILLING IN DIFFERENT MEDIA

<u>Time (Hours)</u>	<u>Air²⁾</u>	<u>Argon²⁾</u>	<u>Acetone¹⁾</u>
0	0.01	0.01	0.17
8	0.17		
16	0.29	0.18	0.50
32	0.57		
72		0.32	1.16

1) Material K-1 was used (see Table 9).

2) Material K-2 was used.

Only few data of oxygen pick-up during ball milling are available so far. They are given in Table 10 and plotted in Figure 5. There seems to be a straight line relationship between oxygen pick-up and time in ball milling in air. The results for ball milling in argon make it appear quite certain that either the ball mill is leaking, or that the air is not completely replaced by argon. It is quite probable that a very small amount of air is occluded by the starting material and is not replaceable by argon.

The main question still to be answered is, how does ball milling affect the composition of the powder after removing all those picked up products which are removable by an acid leach or other means? Experiments have been started with powder ball milled in water and carbon tetrachloride and the results obtained so far are given in Table 8. The oxygen determinations are still missing, but from the fact that these analyses total

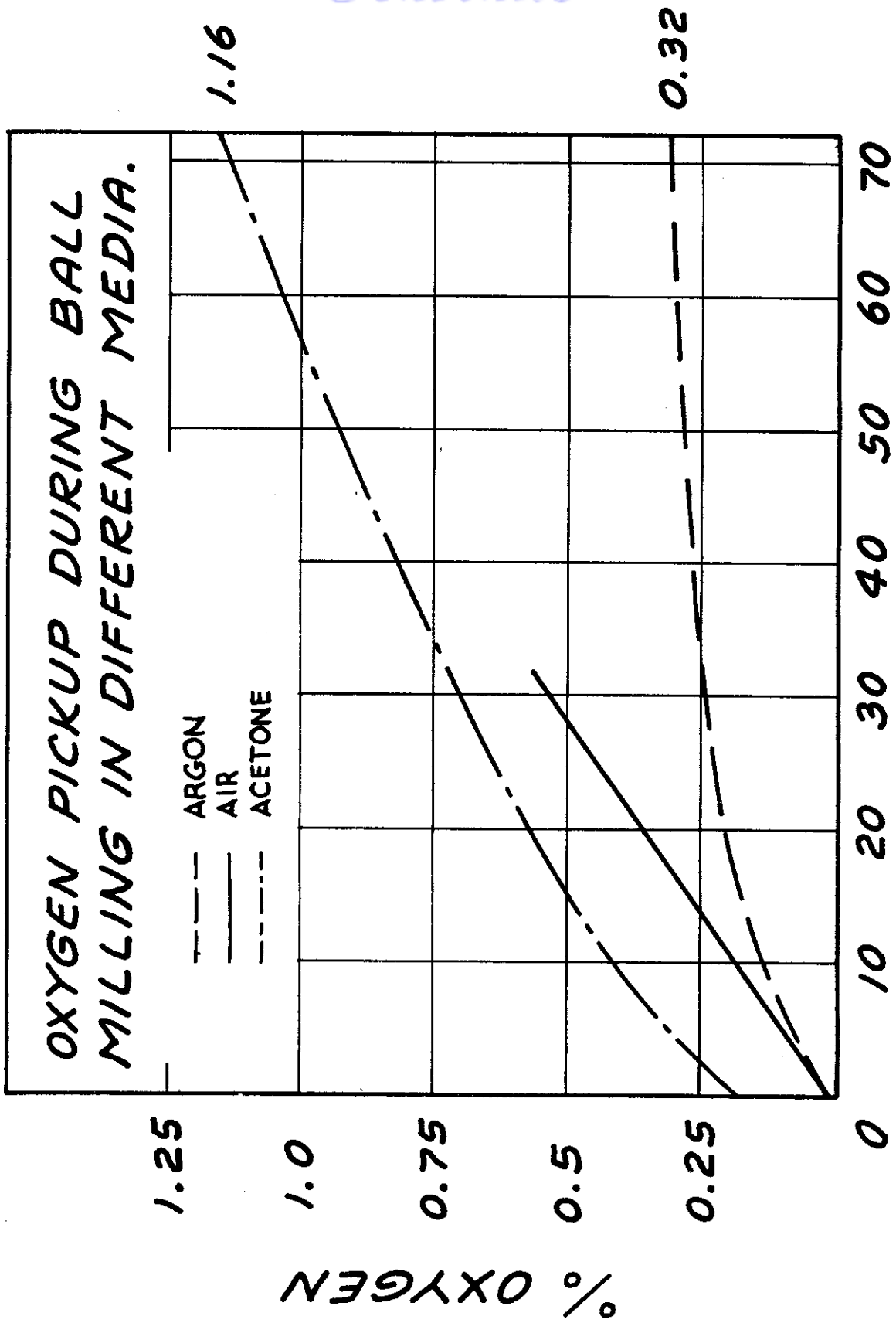

HOURS
FIG. 5

up to 100%, it can be concluded that the picked up oxygen is completely removed by leaching. The increase in combined carbon is to be noted.

Ball milling in a tungsten carbide mill with acetone results in a considerable oxygen pick-up, which after 16 and 72 hours of ball milling amounts to 0.49% and 1.16%, respectively. Leaching the powder which had been ball milled for 72 hours with hydrochloric acid reduces this oxygen content by 0.59% and the titanium content at the same time by 0.89%. The ratio of titanium and oxygen lost during leaching indicate that TiO_2 is removed during this process. Powder as received does not lose titanium during leaching.

It can be concluded from these experiments, that part of the oxygen picked up during ball milling is present in the form of TiO_2 and iron oxide (if ball milling is done in a steel mill) and that leaching removes these oxides. Additional oxygen determinations, which are not yet available, will determine if oxygen is also taken up in a form not removable by an acid leach.

TABLE 11

% WC PICKED UP DURING BALL MILLING IN TUNGSTEN CARBIDE MILL

<u>Time (Hours)</u>	<u>Air</u>	<u>Water</u>	<u>Acetone</u>
16	—	6.56	6.44
72	2.71	9.37	10.03

Experiments show that the amount of tungsten carbide picked up during ball milling in a tungsten carbide ball mill also varies considerably with time and ball milling medium. Table 11 shows the amounts of

Contrails

tungsten carbide picked up during ball milling for 16 and 72 hours in air, water and acetone. Here too, the pick-up in a liquid medium is much higher than in dry ball milling. The explanation proposed for this occurrence in connection with ball milling in a steel mill holds true also for this case.

Conclusions:

1. Particle size reduction is a function of time and independent of ball milling medium.
2. Oxygen, iron and WC pick-up are a function of ball milling medium and ball milling time. Organic liquids are more corrosive towards a steel mill than water. Iron pick-up in a gas-filled ball mill is lower than in one containing liquid by a factor of 10.
3. Carbon tetrachloride and trichloroethylene decompose to a certain degree by ball milling, causing an increase of free C and the presence of Cl in the powder.
4. At least part of the oxygen picked up by ball milling is present in the form of TiO_2 which can be removed by an acid leach.

VI. HOT PRESSING

Introduction

This phase of the work is concerned with the influence of raw material production variables on the manufacture of test specimens. For preliminary evaluation the density of the test specimen has been the only physical property used to evaluate the effects of the raw material production variables.

The original intention had been to hot press test bars $3'' \times \frac{1}{4}'' \times \frac{1}{4}''$ from the various powders. However, it was found somewhat difficult to keep temperature conditions constant over the entire length of the bar. Therefore, the bars pressed have the dimensions $1\frac{1}{2}'' \times \frac{1}{4}'' \times \frac{1}{4}''$.

Materials received from Kennametal, Inc., Norton Company, Metallwerk Plansee, Metro Cutanit and Titanium Alloy are ball milled to average particle sizes between one and 2.5 microns, leached with acids, if the removal of iron is desired, and eventually hot pressed to as high a density as can be obtained. All of the results in this section refer to materials without binder.

Techniques of Hot Pressing

Bars of $1\frac{1}{2}'' \times \frac{1}{4}'' \times \frac{1}{4}''$ are hot pressed by the following procedure:

1. 6.5 to 8 grams of TiC powder are pressed cold in a graphite die with a pressure of 1 to $1\frac{1}{2}$ psi.
2. With the pressure still on, the specimen is brought to the desired temperature by resistance heating.
3. When the desired temperature is reached, the current is either shut off immediately or left on for a certain length of time (up to one minute).

Contrails

4. The current is then turned off allowing the piece to cool rapidly.
5. The pressure is released when the temperature indicator reaches 1700° C.^{*)}
6. Finally, the specimen is either allowed to cool in the graphite die or removed while still glowing and allowed to cool slowly in air.

Hot pressing is done at various temperatures to produce bars of different densities. The reason for this is to obtain physical property values for various densities. Some bars have to be held at temperature for times up to one minute to obtain the maximum densities for a given powder.

Influence of Production Variables on Optimum Densities

Table 12 describes the preparation of the various powders and enumerates their average particle sizes before hot pressing, as well as maximum densities obtained by the technique used. All densities above 90% are determined by the water displacement method. Bars below 90% density are measured with a micrometer caliper for volume determination.

Per cent density is based on the composition of the powder before hot pressing. Titanium carbide ($d = 4.99$), carbon ($d = 2.2$) and tungsten carbide ($d = 15.7$) are the major constituents that influence the density. All others proved to be unimportant for theoretical density calculations.

Kennametal Powders

Of all powders received, the Kennametal powder has the highest purity. For this reason, most of the work has been done with this starting material. Various techniques of milling have been used on this material, which as received has an average particle size of 32 microns. In some instances, the materials have been micronized and then ball milled, and in

*) The temperature recorded is the outside die wall temperature, it is measured by a Rayo-tube and a Leeds & Northrup Speedomax Recorder.

Contrails

TABLE 12

POWDER PREPARATION, PARTICLE SIZE OF POWDERS AND
MAXIMUM DENSITY OF HOT PRESSED BARS

<u>Powder No.</u>	<u>Preparation of Powder</u>	<u>Particle Size Microns</u>	<u>Maximum Density g/cc.</u>	<u>% Density</u>
100	Micronized, ball milled	2.24	4.52	92
100C*	Ball milled 32 hours	2.05	4.62	94
103	Ball milled 16 hours in argon	2.64	4.53	92
104	Ball milled 72 hours in argon	1.41	4.74	96
105	Micronized, ball milled with 0.25% C	2.28	4.59	94
106	Micronized, ball milled with 0.5% C	2.40	4.66	95
107	Micronized, ball milled with 1.0% C	2.45	4.71	97
108	Micronized, ball milled, leached with HCl	2.38	4.70	95
109	Micronized, ball milled with 1% C, leached with HCl	2.40	4.77	99
110	Micronized, ball milled with 0.25% C, leached with HCl	2.20	4.61	95
111	Micronized, ball milled with 0.5% C, leached with HCl	2.60	4.74	97
112	Micronized, ball milled 119 hours, leached with HCl	1.75	4.91	100
113A	Micronized, ball milled, leached once with acetic acid	2.00	4.71	96
113B	Micronized, ball milled, leached twice with acetic acid	2.00	4.74	96
114	Micronized, ball milled with 1% C, leached with acetic acid	2.10	4.84	99
115A	Ball milled 238 hours	1.28	4.85	99
115B	Ball milled 238 hours, leached with HCl	1.28	4.83	99
115C	Ball milled 119 hours	(1.75)		
116	Ball milled with 1% WC,) leached	2.0	4.78	96
117	Ball milled with 3% WC,) with	2.2	4.63	91
118*	Ball milled with 10% WC,) HCl	2.2	4.80	92

Contrails

TABLE 12 - Continued

POWDER PREPARATION, PARTICLE SIZE OF POWDERS AND
MAXIMUM DENSITY OF HOT PRESSED BARS

Powder No.	Preparation of Powder	Particle Size Microns	Maximum Density g/cc	% Density
119*	Ball milled with 1% TiN,) leached	1.8	4.51	92
120*	Ball milled with 3% TiN,) with	1.9	4.43	90
121*	Ball milled with 10% TiN,) acetic acid	1.6	4.4	89
122*	Ball milled with 1% TiO,) leached	2.0	4.42	90
123*	Ball milled with 3% TiO,) with	2.1	4.33	88
124*	Ball milled with 10% TiO,) acetic acid	2.3	4.22	86
125*	Ball milled with 10% Ni	2.2	5.15	100
126*	Ball milled 40 hours (300 g. load)	2.0		
127*	Powder #126 leached with HCl, mixed by tumbling with 10% Ni	(2.0)	5.13	99.5
128*	Powder #126 leached with HCl, mixed by tumbling with 1% WC and 10% Ni	(2.0)	5.08	98
129*	Ball milled with 10% WC 195 hours dry plus 48 hours in water	1.3	5.21	99
130 ⁺	Ball milled 72 hours with water in WC mill	0.8	5.30	100
131 ⁺	Powder #130 leached with acetic acid		5.21	99
132 ⁺	Powder #130 leached with HCl		5.27	100
134	R-1 ball milled	2.10	4.66	95
135	R-4 ball milled	2.50	4.52	92
136	R-3 ball milled	2.30	4.58	93
137	MC-1 ball milled	2.30	4.60	93
138/C-0.2	N-2 flotation purified 0.25% C	1.65	3.95	80
138/C-1	N-2 mixture of 138/C-12 + 138/C-0.2 1% C	1.55	3.75	77
138/C-3	N-2 " " " " 3% C	1.25	4.12	87
138/C-8	N-2 flotation purified 8.3% C	0.90	4.22	95
138/C-12	N-2 as received 12% C	0.70	3.64	85
138/C-20	N-2 flotation overflow 28.7% C	0.38	3.09	85

+ K-1 powder used (see Table 9)

* K-3 powder used

K-2 powder used for all others, unless special code number is given.

Contrails

others the powders have just been milled for different lengths of time in steel or tungsten carbide mills.

Since the impurity content is low (see Table 9), several impurities have been added to the powders to determine their effect on hot pressing. These additions include free carbon, tungsten carbide, titanium nitride and titanium monoxide.

Powders have also been purified to some extent after particle size reduction. During micronizing and also during ball milling in a steel mill, powders pick up iron and oxygen. Most of the iron and part of the oxygen (probably the part present in the form of an oxide film), can be removed by leaching with 1:3 hydrochloric acid. Leaching with 1:1 acetic acid, on the other hand, also removes iron but seems not to attack the oxides or nitrides of titanium. Leaching has been performed on a powder milled in a tungsten carbide lined mill to remove cobalt, which is present as a binder in the lining of the mill and in the tungsten carbide balls.

The following conclusions on the Kennametal powders may be drawn from Table 12:

1. Decreasing the particle size increases optimum density. Compare powders 103 and 104, 108 and 112, 118 and 129.
2. Increase of free carbon content in the amounts investigated increases the optimum density. Compare powders 100, 105, 106 and 107.
3. Purification of powders by leaching with HCl increases optimum density. Compare powders 100 and 108, 105 and 110, 106 and 111, 107 and 109.
4. Leaching with acetic acid does not show any significant change of

Contrails

Maximum density compared with hydrochloric acid leaching.

Compare powders 108 and 113B, 109 and 114.

5. Additions of more than 1% tungsten carbide decrease the final per cent density. Compare powders 108 and 116, 117, 118.
6. The condition in (5) can be improved by a reduction in particle size. See powder 129.
7. Additions of titanium nitride tend to decrease the density. Compare powders 113B and 119, 120, 121.
8. Additions of titanium monoxide also reduce the final density. Compare powders 113B and 122, 123, 124.
9. Leaching of cobalt from the tungsten carbide milled powders does not greatly influence the optimum density. Compare powders 130, 131, 132.

Metallwerk Plansee Powders

Four less pure grades (Table 13) of about 5 microns particle size have been received from the Metallwerk Plansee. The only treatment given to these powders before hot pressing is a particle size reduction.

TABLE 13

ANALYSES OF TiC POWDERS PURCHASED FROM METALLWERK PLANSEE

	<u>R-1</u> ^{*)}	<u>R-2</u> ^{*)}	<u>R-3</u> ^{*)}	<u>R-4</u>
Ti	79.3	73.2	79.7	79.1
C comb	17.8	16.95	18.2	18.7
C free	0.73	0.16	0.42	0.63
Fe	0.13		0.10	0.10
W				0.40
Si				0.19
Mo		4.32		
O ₂				1.05
N ₂	0.97	0.82		0.57

*) Analyses incomplete

Contrails

There appears to be no great difference in optimum density obtainable by hot pressing these powders and the Kennametal powders which received the same treatment.

Metro-Cutanit Powder

This relatively pure grade of powder, received from the Metro-Cutanit Company of England, has a particle size of 5.6 microns. As in the case of the Reutte powders, this powder is also only ball milled to reduce the particle size. The optimum density does not vary from a comparable Kennametal powder.

Norton Powder

The Norton technical grade powder, 0.7 microns as received, has been flotation purified to reduce the free carbon content. Since the measured particle size increases with decrease in free carbon, it is difficult to evaluate this powder. All that can be concluded from Table 12 is that the hot pressed density is in general very poor and that the density appears to increase and then decrease with increasing free carbon content.

Titanium Alloy Powders

Up to the present time, very little work has been done on these materials but extensive work is planned for them in the future.

Conclusions

- A. In general, the finer the particle size of the powder the higher the density obtainable by hot pressing. Above a particle size of about 3 microns, hot pressing becomes difficult. The optimum size for best results appears to be below 2 microns in all cases except the Norton technical grade.

Contrails

B. The impurity content of a powder plays an important part in the final density of a hot pressed bar. Small additions of free carbon tend to increase the final density while additions of iron, oxides, nitrides and tungsten carbide tend to decrease the per cent density. The decrease in density due to the presence of tungsten carbide can be overcome by using finer particles. Whether the influence of oxides and nitrides can also be overshadowed with finer particle size, is a problem for further study.

The reason for the poor hot pressing of the Norton technical grade powder is still under investigation. The material has a fine particle size but its impurity content is exceptionally high. These impurities definitely affect the hot pressing ability of this powder.

VII. ELECTRICAL RESISTIVITY MEASUREMENTS

For these measurements a special bar holder was designed and made in our machine shop. Figure 6 shows a picture of its front view. The assembly can easily be immersed in a constant temperature bath to take measurements at different temperatures. With this set-up, bars hot pressed from various powders have been tested for electrical resistivity at 100° C. and the influence of particle size, free carbon content, and acid leach of powders before hot pressing has been investigated. Following are the results obtained:

1. Differences in particle size of a powder do not influence resistivity.
2. Presence of an excess of free carbon before hot pressing, which was investigated up to 1%, also does not influence resistivity.
3. Leaching of a powder with hydrochloric acid lowers the resistivity by about 10 microhm-centimeters at all densities.
4. The resistivity decreases, as expected, with increasing density. The lowest resistivity measured with all investigated powders on bars of about 95% of theoretical density was about 85 microhm-centimeters.

In the belief that the thermal coefficient of electrical resistivity might be more sensitive to the influence of impurities than resistivity itself, this coefficient has been determined for a number of specimens between -60° and 100° C. The results are not conclusive. After improving the sensitivity of the set-up, the coefficient will be measured for a wider range of temperatures.

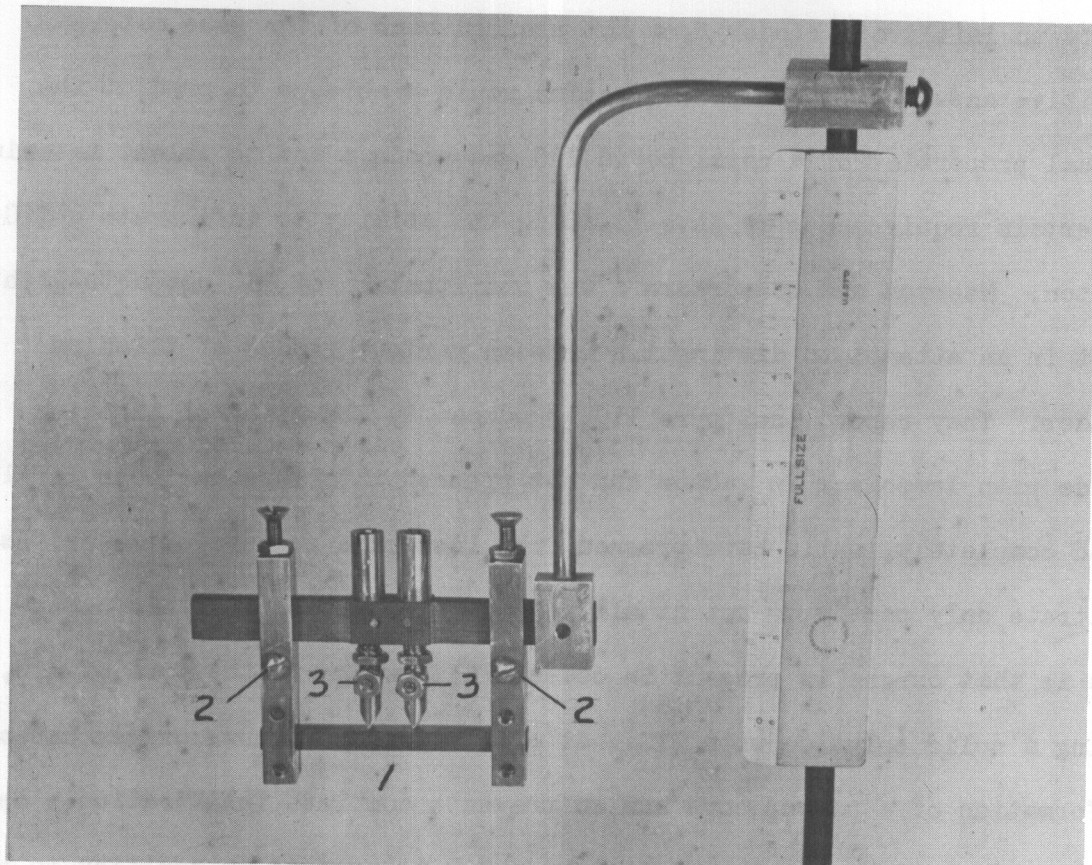

1. Test Bar
2. Wire Connections to Battery and Ammeter
3. Wire Connections to Potentiometer

FIG. 6 SPECIMEN HOLDER FOR ELECTRICAL RESISTIVITY MEASUREMENTS

VIII. INFILTRATION EXPERIMENTS

The aim of these experiments is twofold: (1) to investigate the factors which influence the ability to infiltrate porous titanium carbide compacts with a liquid metal, and (2) to find out if a correlation exists between physical properties of binder containing hot pressed pieces and the ability to infiltrate binder free hot pressed bars of the same material. A positive answer to the second question would enable us to predict the physical properties of a metal bound TiC end-product and to select materials for certain requirements by investigating the ability to infiltrate a TiC skeleton. Meerson and co-workers¹⁾ use infiltration of TiC compacts with cobalt in an attempt to distinguish between various grades of titanium carbides. They report that pure TiC, produced by reduction of titanium dioxide with lampblack in vacuum and hot pressed into bars, has been infiltrated completely, while bars pressed from less pure commercial materials infiltrate only partly or not at all. Their explanation for this occurrence is that oxygen is present in commercial powders in the form of TiO, forming a solid solution with TiC. At elevated temperatures oxygen causes the formation of a porous core and so prevents complete infiltration. As this core formation also takes place when TiC is used as an addition to WC, infiltration experiments can reveal if a certain grade of titanium carbide can be used for the production of sound WC-TiC compacts. Figure 7 is taken from Meerson's publication. Numbers 1 and 3 are bars of a "normal commercial titanium carbide" with about 17% combined and 1% free carbon and 3%

1) G. A. Meerson, G. L. Zverev and B. Ye. Osinovskaya, Zhurnal Prikladnoi Khimii 13, 1675 (1940) translated by H. Bratcher.

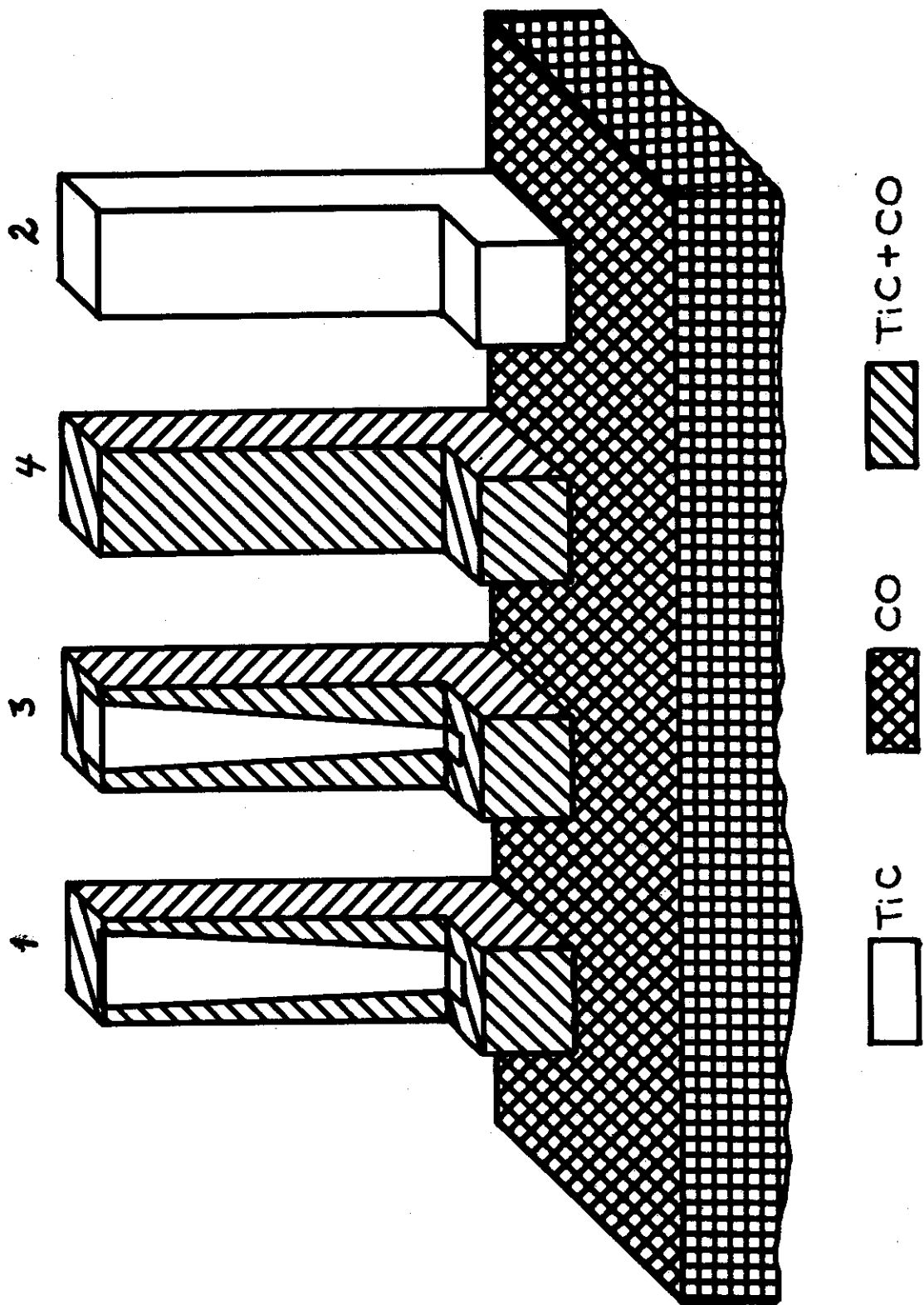

FIG. 7 INFILTRATED BARS ACCORDING TO MEERSON

Contrails

oxygen. They infiltrate only partly. Number 2 is a bar of a titanium carbide which causes core formation; the analysis of this material is given as 17.2% combined and 1% free carbon and 3.25% oxygen. It does not infiltrate at all. The completely infiltrated bar 4 is vacuum produced TiC, with 19.2% combined and 0.4% free carbon and 1% oxygen. The oxygen percentages are calculated by difference, analyses for nitrogen or other impurities are not given. Densities of bars are not mentioned.

Our infiltration experiments are carried out in a very similar way to those of Meerson. Compacts $1\frac{1}{2}$ " x $\frac{1}{4}$ " x $\frac{1}{4}$ ", hot pressed from various powders and of various densities (See Table 14), are placed in small graphite crucibles containing cobalt powder. The amount of cobalt used is in a slight excess of that required to completely infiltrate the pore space. Several small crucibles are then inserted in a larger insulated graphite crucible. The temperature of this system is rapidly raised by high frequency induction heating to 1550° C. and held for one hour. Dry hydrogen is passed through the assembly to prevent oxidation. After cooling, the infiltrated bars are ground down to half their initial thickness, the depth of infiltration is measured in inches and recorded in numbers ranging from 0 (no infiltration) to 6 (complete infiltration) and using \pm signs according to Figure 8. After this grinding operation infiltrated bars present typical patterns as shown in Figure 9.

Not considering the uninfiltrated part, it is possible to distinguish three regions in the infiltrated part of many bars. The first region (A in Figure 9) consists of TiC particles surrounded by cobalt; molten cobalt dissolved some TiC which reprecipitated on cooling. The second region (C in Figure 9) seems to indicate a diffusion of cobalt into

REPORTING OF INFILTRATION RESULTS

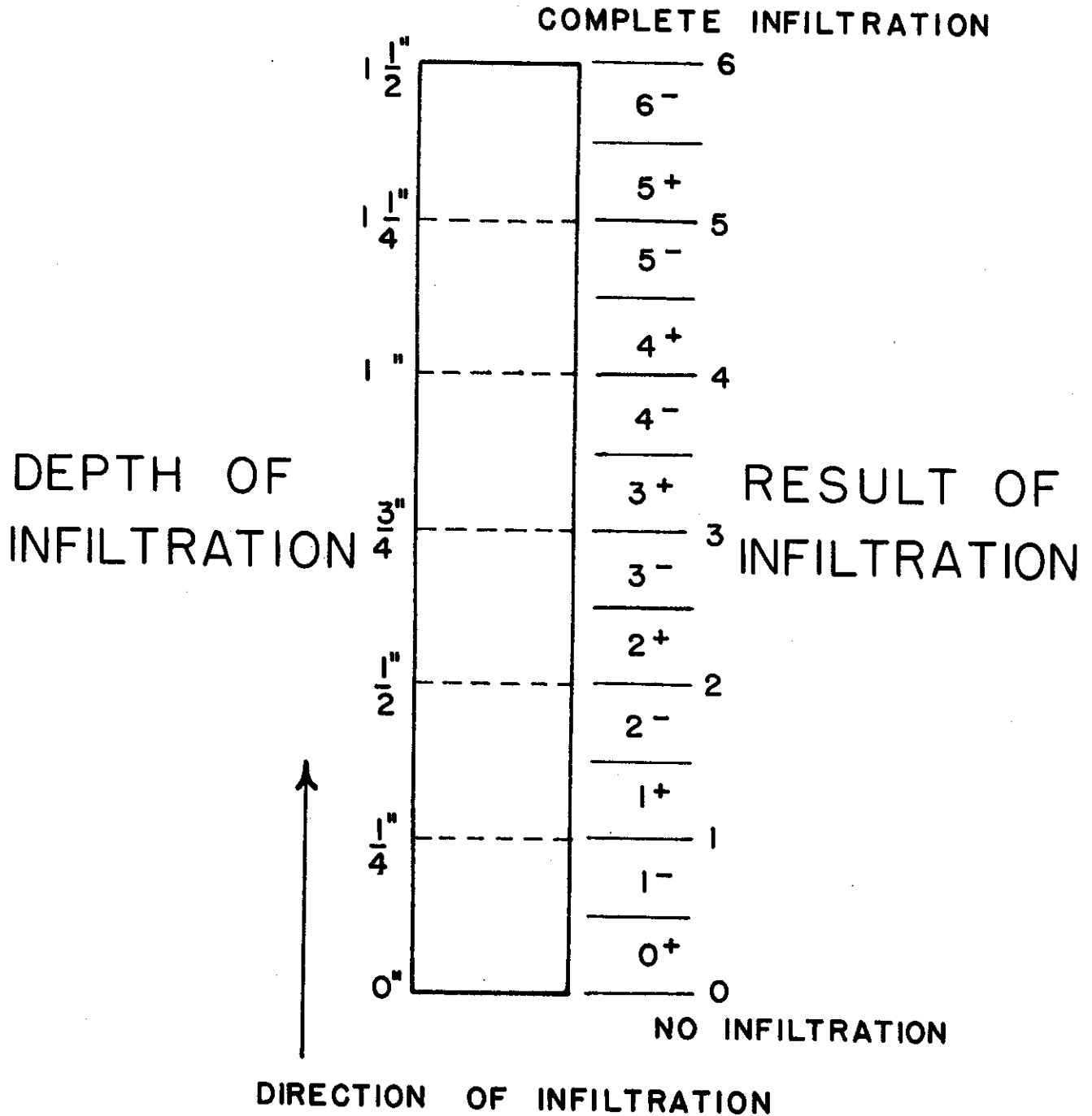
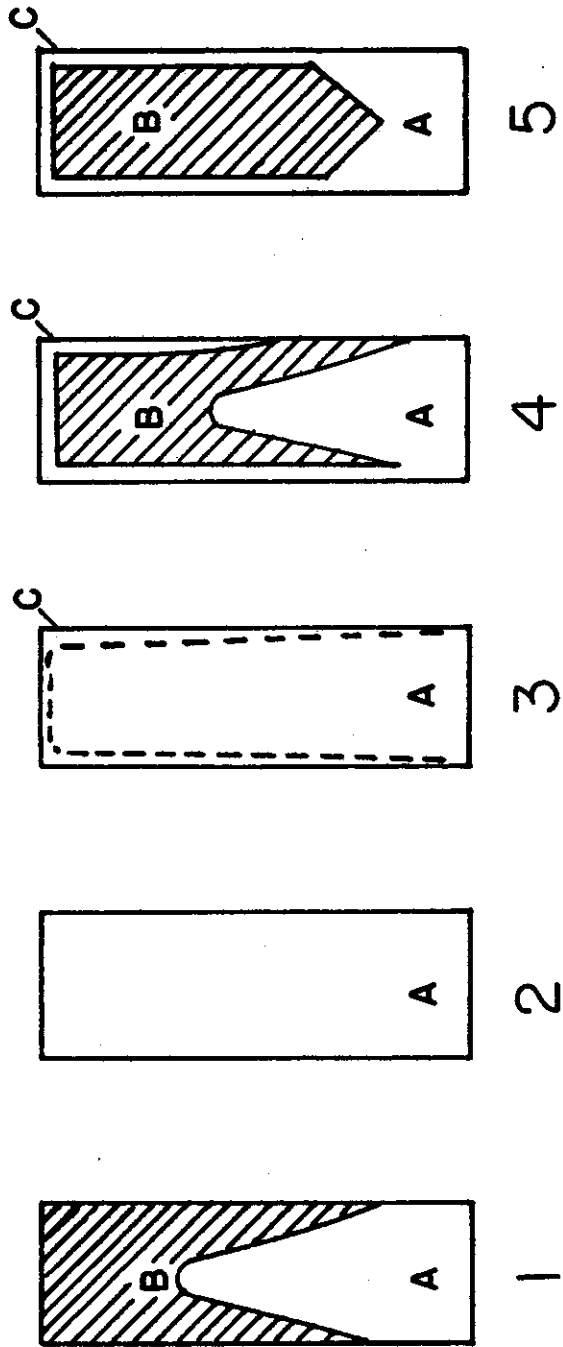

FIG. 8

INFILTRATED BARS



- 1) PARTIAL INFILTRATION
 - 2) COMPLETE INFILTRATION
 - 3) COMPLETE INFILTRATION AND DIFFUSION
 - 4) PARTIAL INFILTRATION AND DIFFUSION
 - 5) PARTIAL INFILTRATION AND DIFFUSION (?)
- A) INFILTRATED PART
 - B) NON-INFILTRATED PART
 - C) INFILTRANT DIFFUSED INTO TIC

FIG. 9

Contrails

TABLE 14

INFILTRATION STUDY

Kennametal Powder

<u>Powder/Specimen No.</u>	<u>Powder Preparation</u>	<u>Particle Size Microns</u>	<u>Density %</u>	<u>Infiltration Result</u>	<u>Type</u>
100b/9	Micronized, ball milled steel mill, dry	2.24	81.2	4 ⁻	1
11			76.9	4 ⁺	1
12			76.5	5 ⁺	1
13			74.9	6	2
*100c/11	ball milled steel mill, dry	2.05	88.3	2 ⁻	5
5			86.3	2 ⁻	5
6			82.3	6 ⁻	4
7			78.2	6	2 or 4
8			76.0	6 ⁻	4
12			64.4	6	2
103/13	ball milled steel mill, argon	2.64	77.5	2 ⁺	1
14			77.3	1 ⁺	1
31			76.6	0	--
33			71.4	6	2
25			60.0	0	1
26			60.0	0	--
104/16	ball milled steel mill, argon	1.41	81.2	6 ⁻	1
23			75.0	6	2
24			74.5	6	2
25			73.9	6	2
105/9	ball milled + 0.25% C steel mill	2.28	81.8	2 ⁻	1
7			81.6	1 ⁺	1
19			74.3	6 ⁻	1
17			60.0	4 ⁻	1
106/10	ball milled + 0.5% C steel mill	2.40	81.4	2 ⁺	1
8			81.4	2 ⁺	1
21			73.0	6 ⁻	1
20			60.0	5	1
107/8	ball milled + 1% C steel mill	2.45	82.6	0	--
20			77.8	0	--
18			71.5	6 ⁻	1
19			71.2	6	2
17			60.0	2 ⁺	--

Contrails

TABLE 14 - Continued

(INFILTRATION STUDY)

<u>Powder/Specimen No.</u>	<u>Powder Preparation</u>	<u>Particle Size Microns</u>	<u>Density %</u>	<u>Infiltration Result</u>	<u>Type</u>
108/14	Micronized,	2.38	81.2	0	5?
19	ball milled		71.5	0	5?
17	steel mill, leached HCl		60.0	0	5?
109/12	micronized,	2.40	86.1	0	5
25	ball milled		77.5	0	—
24	+ 1% C,		74.7	0	5
22	leached HCl		73.5	0	5?
110/16	micronized,	2.2	79.7	0	—
17	ball milled		79.2	0	5
15	0.25% C,		70.2	0	—
14	leached HCl		60.0	0	—
111/16	micronized,	2.6	84.1	0 ⁺	5
15	ball milled		74.7	2 ⁺	4
17	0.5% C, leached HCl		60.0	2 ⁺	5
112/18	micronized,	1.75	78.7	6	2
16	ball milled		75.8	5 ⁺	4
19	steel mill, leached HCl		74.6	6	2
113B/11	micronized,	2.00	83.9	6	2 or 4
9	ball milled steel mill, leached HAc		72.5	4 ⁺	1 or 4
114/9	micronized,	2.10	84.7	0 ⁺	5
15	ball milled		78.6	3 ⁺	1 or 4
14	+ 1% C,		71.8	3 ⁺	1 or 4
13	leached HAc		70.0	6	2
12			70.0	6 ⁻	1
11			60.0	—	4
115A/9	ball milled	1.28	86.7	6	2
10	steel mill		84.3	6	2
6	238 hrs. dry		73.7	6	2
11			73.4	6	2
115B/7	ball milled	1.28	84.5	0 ⁺	5
8	steel mill		74.1	6 ⁻	4
5	238 hrs.,		70.0	6	3
6	leached HCl		69.8	6	2
9			58.4	1 ⁺	5

Contrails

TABLE 14 - Continued
(INFILTRATION STUDY)

<u>Powder/Specimen No.</u>	<u>Powder Preparation</u>	<u>Particle Size Microns</u>	<u>Density %</u>	<u>Infiltration Result</u>	<u>Type</u>
116/12	Ball milled	2.0	79.2	7	5
13	+ 1% WC,		75.3	6	2
18	leached HCl		57.4	7 ⁻	5
17			56.4	5	5
117/2	ball milled	2.2	79.2	4	5
1	+ 3% WC		75.9	6	2
8	leached HCl		61.0	6	2
*118/15	ball milled	2.2	80.0	6	2
14	+ 10% WC,		69.0	6	2
17	leached HCl		55.8	6	2
*119/5	ball milled	1.8	81.4	6	2
6	+ 1% TiN,		73.1	6	2
9	leached HAc		60.0	5 ⁻	4
*120/7	ball milled	1.9	79.8	6	2
8	+ 3% TiN		72.6	6	2
	leached HAc				
*121/7	ball milled	1.6	76.3	6	2
8	+ 10% TiN,		70.4	6	2
9	leached HAc		60.3	6	2
*122/7	ball milled	2.0	77.0	5 ⁻	4
8	+ 1% TiO,		70.0	6	2
9	leached HAc		61.2	6	2
*123/7	ball milled	2.1	82.7	6	2
8	+ 3% TiO,		74.0	6	2
9	leached HAc		61.2	6	2
*124/6	ball milled	2.3	76.7	probably diffusion only	
7	+ 10% TiO,		68.5	3	5?
8	leached HAc		57.6	6	2
*129/6	ball milled	1.2	82.8	6	2
7	+ 10% WC		68.0	6	2
8	steel mill		61.7	6	2
*130/4	ball milled	0.8	73.0	6	2
	WC mill, water				

Contrails

TABLE 14 - Continued
(INFILTRATION STUDY)

<u>Powder/Specimen</u> <u>No.</u>	<u>Powder</u> <u>Preparation</u>	<u>Particle</u> <u>Size</u> <u>Microns</u>	<u>Density</u> <u>%</u>	<u>Infiltration</u> <u>Result</u>	<u>Type</u>
+142/1	Ball milled,	1.42	66.5	6	2
2	WC mill,		79.3	6	2
3	water		53.4	6	2
+144/1	ball milled,	1.6		6	2
2	WC mill, dry			6	2
3				6	2

+ K-1 powder used for these experiments (See Table 9)

* K-3 powder used for these experiments.

K-2 powder used for all other experiments.

TiC and is found on the top and sides of some bars. Figure 10 shows photomicrographs and a sketch indicating the location of the different regions in a typical bar. Identification of regions 1 and 2 was done by x-ray diffraction analysis. In region 1, (Figure 10, picture 4), the x-ray revealed pure TiC ($a_0 = 4.325 \text{ \AA}$) and cobalt. In region 2, (Figure 10, picture 2), the TiC lines were shifted ($a_0 = 4.28 \text{ \AA}$), probably due to the presence of cobalt in the TiC lattice. Region 3, which is very small and is the third region mentioned in connection with Figure 9, is a transition region between the other two. (Figure 10, picture 3). The photomicrograph shows very small angular TiC crystals in a cobalt matrix. These small crystals were probably pushed through the fine capillaries by the liquid infiltrant and deposited when the flow of the liquid came to a standstill. They were not dissolved because the infiltrant was already saturated with

FIG. 10

MICROSTRUCTURE OF INFILTRATED BAR

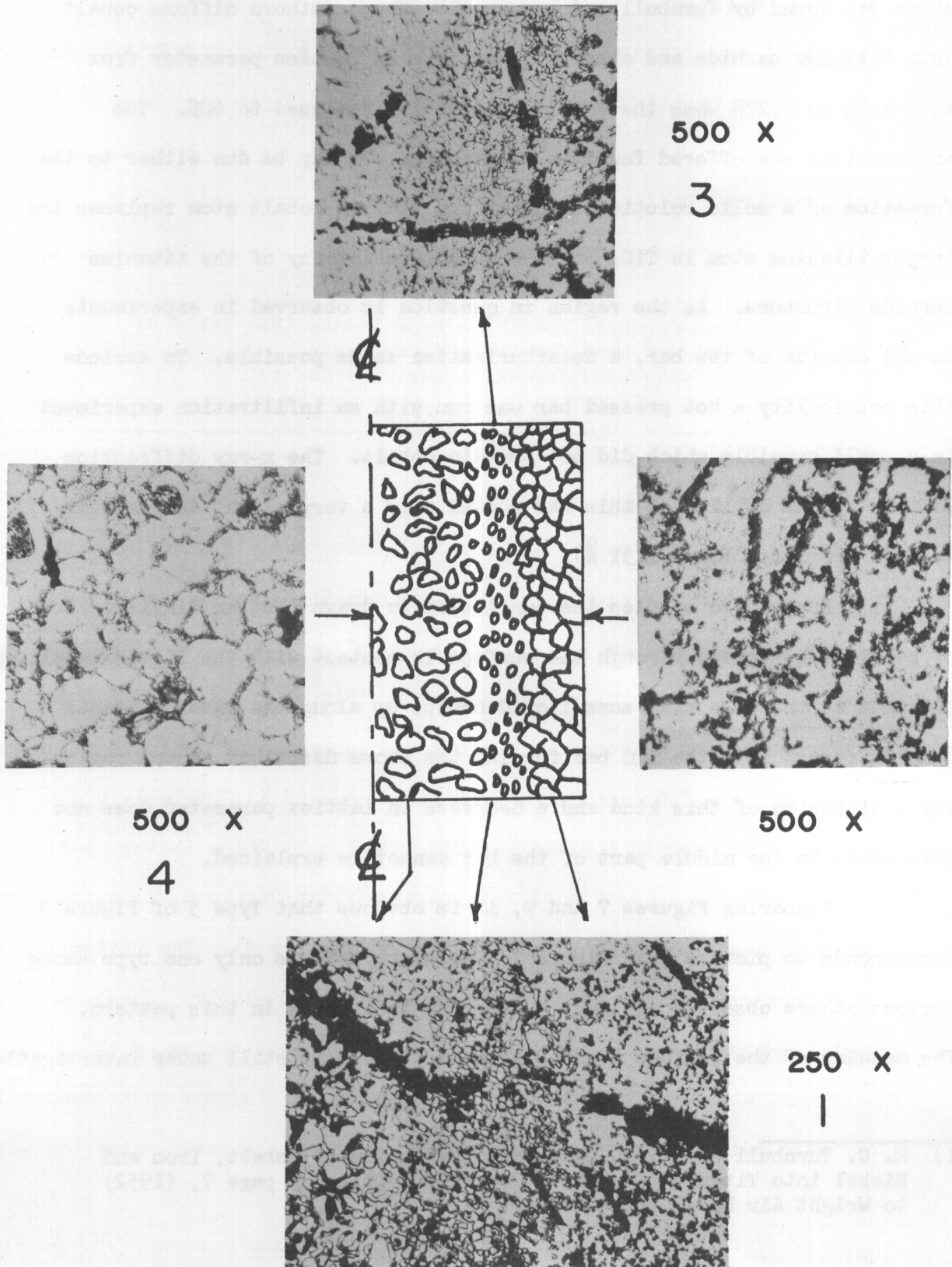

Contrails

titanium carbide by the time it surrounded these crystals.

A decrease in lattice parameter similar to the one described above was found by Turnbull and Lawrence.¹⁾ These authors diffuse cobalt into titanium carbide and observe a decrease in lattice parameter from $a_0 = 4.32$ to 4.278 when the cobalt content is increased to 60%. Two explanations are offered for this occurrence. It may be due either to the formation of a solid solution in which the smaller cobalt atom replaces the larger titanium atom in TiC, or to a carbon deficiency of the titanium carbide structure. As the region in question is observed in experiments on the outside of the bar, a decarburization seems possible. To exclude this possibility a hot pressed bar was run with an infiltration experiment in a small crucible which did not contain cobalt. The x-ray diffraction pattern of the outside of this bar showed only a very slight decrease in lattice parameter ($a_0 = 4.31 \text{ \AA}$).

From these studies the conclusion is drawn that an "infiltration" of cobalt takes place through the surface in contact with the liquid metal, and that at the same time some liquid creeps up along the other surfaces and "diffuses" into the TiC bar forming the above described second region. Why a diffusion of this kind and a decrease in lattice parameter does not take place in the middle part of the bar cannot be explained.

Comparing Figures 7 and 9, it is obvious that Type 5 of Figure 9 corresponds to picture 1 in Figure 7. However, this is only one type among various others observed and only a few bars infiltrate in this pattern. The meaning of the regions A and C in this picture is still under investigation.

1) R. C. Turnbull and W. G. Lawrence, "Diffusion of Cobalt, Iron and Nickel into Titanium Carbide", Progress Report #8, page 7, (1952) to Wright Air Development Center.

Contrails

The explanation given by Meerson and co-workers, blaming the presence of oxygen for lack of infiltration, cannot be substantiated by our results. While a very impure technical grade titanium carbide which might contain a high amount of oxygen does indeed not infiltrate (see Table 15), powder to which 10% of TiO has been added infiltrates at the proper density (powder 124, Table 14). The purest material investigated so far (powder 108, Table 14) did not infiltrate. The oxygen analysis of this powder is 0.1%, the combined carbon 19.3% and the free carbon 0.3%.

Infiltrability is a complex function of various factors which are not yet completely understood.

Tables 14 and 15 list all bars infiltrated so far. They indicate powder preparation and give the average particle sizes of the powders before hot pressing. The % density of the hot pressed bars is based on a density of 4.93 gr/cc for TiC. In mixtures with WC etc., the density is determined on the assumption that the product is a true mixture, although it is known that this is not the case. Results and types of infiltration are recorded as indicated in Figures 8 and 9.

Tables 14 and 15 show that the factors influencing infiltration are particle size, density and impurities.

Particle Size— Depth of infiltration increases with decreasing particle size. (See powders 100b-115A, 103-104, 108-112). Type of infiltration, however, is a function of the base material and cannot be influenced by change of particle size.

Density— It is to be expected that depth of infiltration depends upon the density of the hot pressed bar. The results show there is a density range which gives optimum infiltration. This range gets narrower

TABLE 15

INFILTRATION STUDY

Norton Powder, Technical Grade

<u>Powder/Specimen</u> <u>138 / No.</u>	<u>Powder</u> <u>Fraction</u>	<u>Particle</u> <u>Size</u> <u>Microns</u>	<u>Density</u> <u>%</u>	<u>Infiltration</u> <u>Result</u>	<u>Type</u>
C-0.2/5 7 8	0.25% C	1.65	67.5	2	5
			71.5	0+	5
			55.7	0+	5
C-1/6 7	1% C	1.55	71.0	0+	5
			76.8	0+	5
C-3/8 9 10	3% C	1.25	76.8	0+	5
			72.7	0+	5
			70.0	0+	5
C-8/1 2 3	8% C	0.9	74.5	0+	5
			71.9	0+	5
			60.8	0+	5
C-12/1 2 3	as received	0.7	70.6	0	
	12% C		74.5	0	
			68.0	0	
C-20/1 2	flotation overflow	0.4	60.7	0	
	28.7% C		65.9	0	

Contrails

with increasing particle size and is in general in the neighborhood of 70 to 75% density. The range gets wider with decreasing particle size. (See powders 115A-100b, 100c).

Presence of Impurities-- Leaching of a powder with hydrochloric acid, which removes iron as well as oxide and nitride films, prior to hot pressing decreases the ability to infiltrate. If infiltration occurs at all, it is of Type 5 (Figure 9).

The question, if chlorine is retained in any form when TiC is leached with hydrochloric acid, and its influence, if present, has to be investigated further (powders 108 to 111). Table 8 seems to indicate that there is no retention of chlorine.

Leaching with acetic acid, which removes iron but does not remove any surface films, does not change the ability to infiltrate (powders 113 and 114).

The detrimental influence of the hydrochloric acid leach on infiltration is overcome by the addition of tungsten carbide (powders 116, 117 and 118) or a reduction in particle size (powder 115B).

Powders ball milled in a tungsten carbide mill to a small particle size infiltrate completely at all investigated densities (powders 129, 130, 142 and 144).

The presence of free carbon in the range of up to 1% seems to have no effect on infiltration (powders 105, 106, 107). The influence of higher free carbon contents will be investigated.

The presence of up to 10% TiN does not change the ability to infiltrate (powders 119 to 121).

For TiO the same holds true only if the amount is small (powders

Contrails

122 and 123). The presence of 10% TiO interferes with the infiltration.

The TiN used for these experiments has been purchased from Metal Hydrides. The TiO has been produced by us and is a solid solution of TiC, TiN and TiO, containing 63.5% TiO. (See Chapter III).

An investigation of the correlations between physical properties of hot pressed bars made from various powders and the ability to infiltrate these same powders has been started. It will be carried out in the following way. All powders used in the infiltration study are being mixed with 10% or 20% nickel. These mixtures will be hot pressed and the compacts tested for electrical resistivity, hardness, transverse rupture strength, etc. Nickel was selected for this purpose as it is the usual binder for commercial titanium carbide products. It is hoped that a correlation will be possible between the physical properties of a given hot pressed TiC powder with nickel binder and that particular powder's behavior during infiltration with cobalt.

IX. BINDER STUDY

When titanium carbide is bound with an auxiliary metal, its commercial usefulness is greatly enhanced. Therefore, the present and most of the future work will be concerned with finding the influence of raw material production variables on metal bonded titanium carbide bodies.

Since nickel is the most common of the binding materials employed commercially, it has been the first used for this study. Several experiments have been started to find out the various conditions necessary for the preparation of sound test bars. Bars have been and will be prepared by the following methods:

1. Hot pressing
2. Hydrogen sintering
3. Vacuum sintering

1. Hot Pressing

An experiment was made in which a powder was mixed with 10% nickel by weight and subsequently ball milled to a particle size of approximately 2 microns (powder 125, Table 12). The same TiC powder was ball milled to 2 microns, leached and then tumbled with 10% nickel for 2 hours (powder 127, Table 12).

These two powders were then hot pressed to various densities and microscopic examinations (Figures 11 and 12) were made to compare the distribution of the nickel in the two test bars. As indicated by the photomicrographs, there appears to be little difference in the distribution. Based on these results other powders are being tumbled with nickel, after a preliminary ball milling and leaching treatment of the powders.

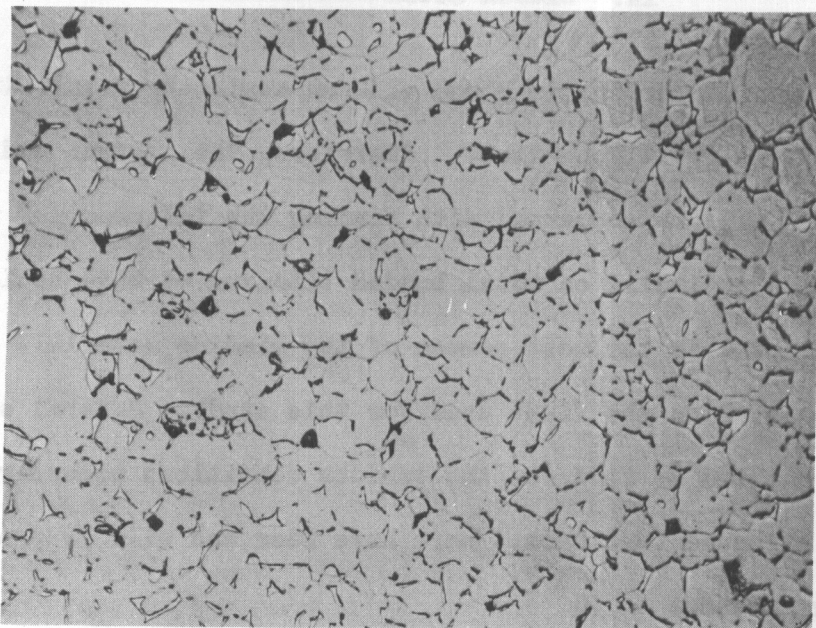

FIG 11 ALK. SODIUM PICRATE ELECTROLYTIC ETCH 500X
TiC BALL MILLED WITH 10% Ni

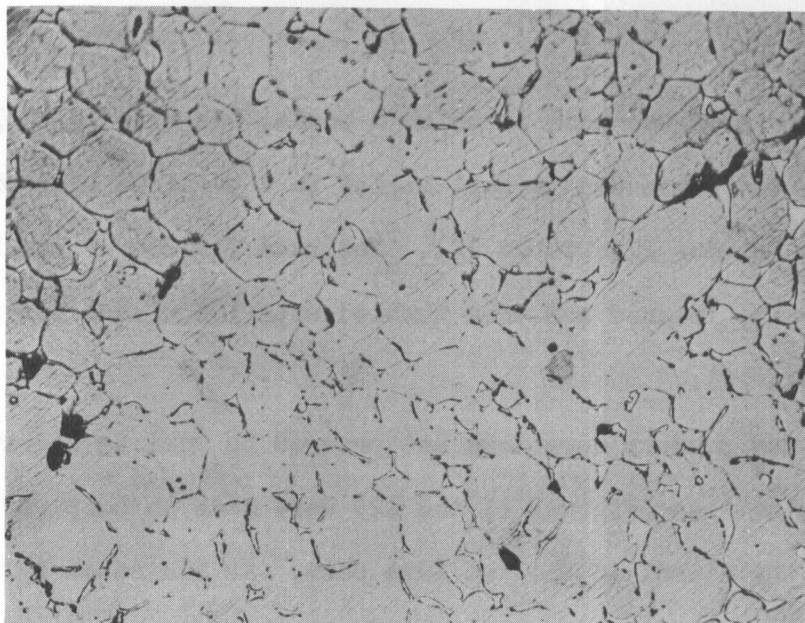

FIG. 12 ALK. SODIUM PICRATE ELECTROLYTIC ETCH 500X
TiC LEACHED AND TUMBLED WITH 10% Ni

Contrails

As yet the only reportable results are those of the first experiment, comparing a powder milled with nickel with a powder which was milled, leached, and then tumbled with nickel. Figure 13 is a plot of transverse rupture strength versus density for these two powders. The powder that was leached and then tumbled with nickel (127) has a lower strength for comparable densities. This might be due either to the tumbling or to the leaching of this powder. To decide this question a powder will be milled to the proper particle size and without leaching tumbled with 10% nickel.

A second experiment has been started. A powder containing 10% titanium nitride has been tumbled with 20% nickel and then hot pressed. The results indicate that an increase of the sintering temperature is necessary to obtain optimum density, probably due to the presence of titanium nitride. Photomicrographs (Figures 14 and 15) were taken of two specimens, one prepared from a low temperature bar and one from a high temperature bar. Obviously, the low temperature bar is very porous indicating poor sintering while the high temperature bar is quite dense. The distinguishing feature of the low density specimen when compared to the high density one is the small areas not outlined by the etching agent and believed to consist of TiN. These areas are neither the color of the outlined binder nor are they the color of the carbide phase. They disappear in the high density bar.

The indications are that the titanium nitride must go into solid solution before proper sintering and binding action can take place. Subsequent experiments will be run to determine the possible reasons for this occurrence.

Other experiments will be run with other added impurities and

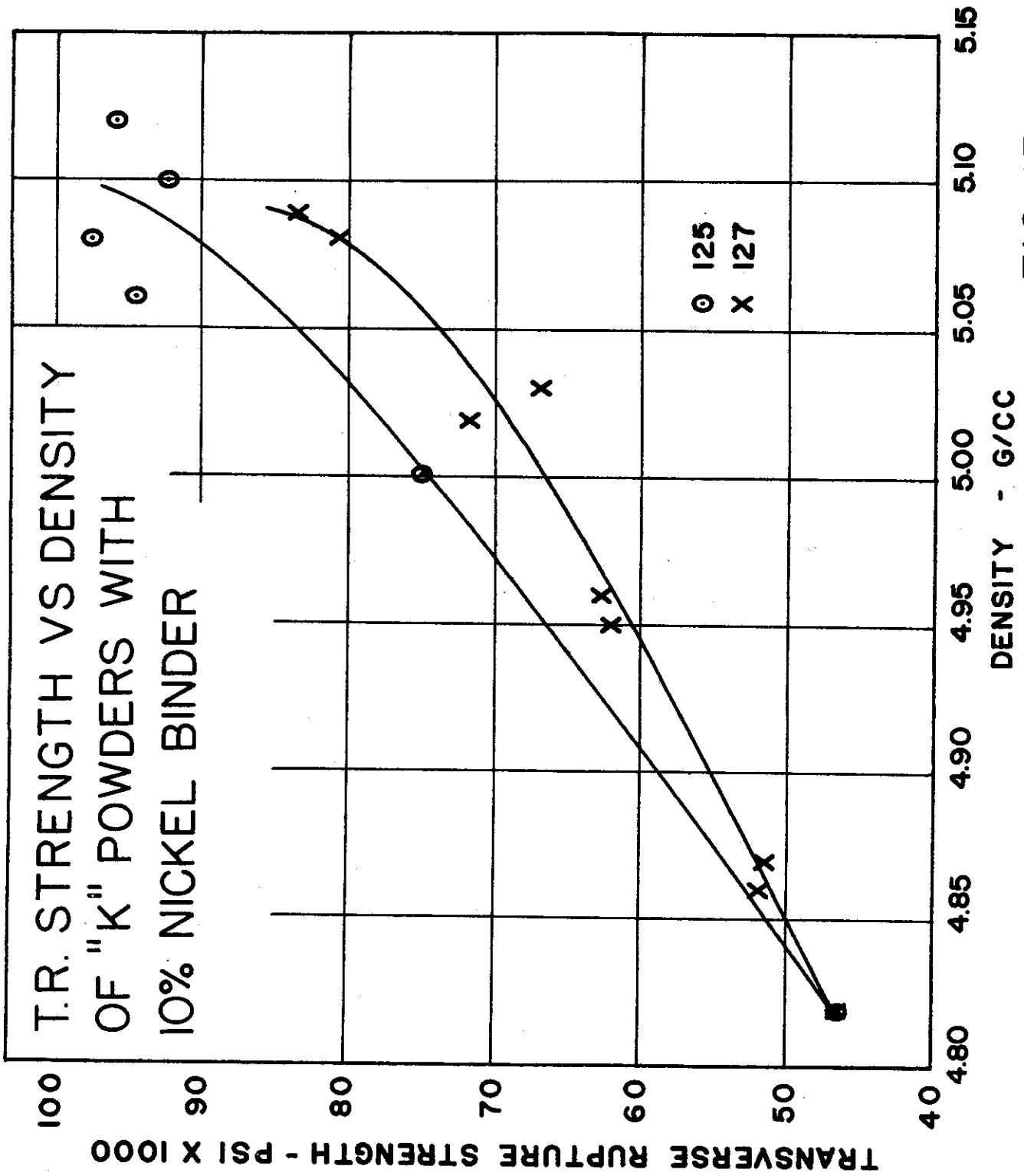

FIG. 13

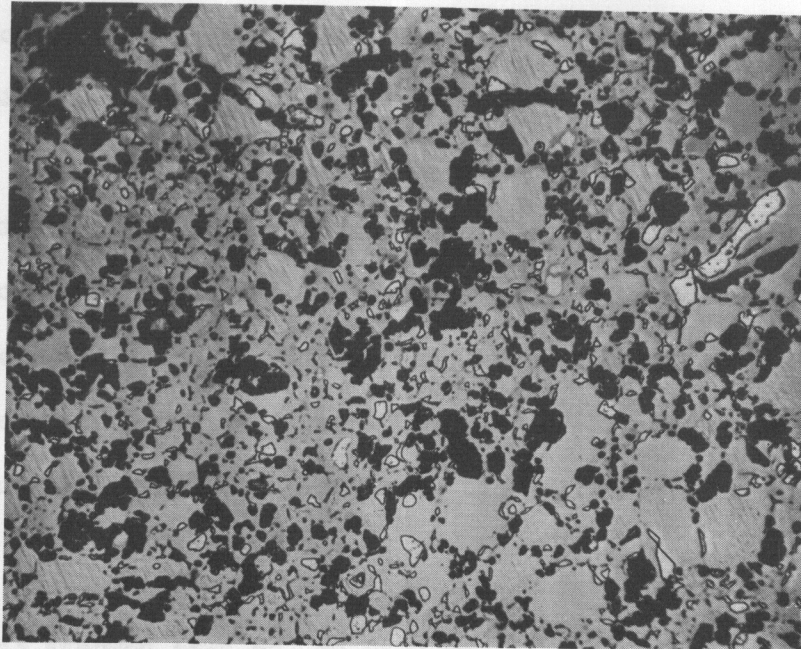

FIG. 14

OXALIC ACID ELECTROLYTIC ETCH
TiC (10% TiN) + 20% Ni

500X
HOT PRESSED 1700°C.

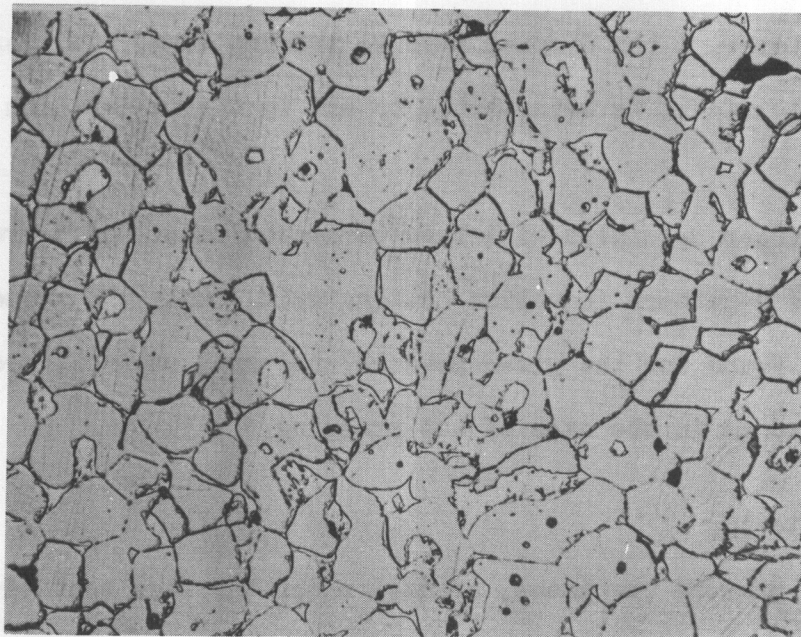

FIG. 15

ALK. SODIUM PICRATE ELECTROLYTIC ETCH
TiC (10% TiN) + 20% Ni

500X
HOT PRESSED 2000°C.

Contrails

20% nickel as the binder, and the physical properties of resultant bars will be tabulated in following reports. Among the properties to be investigated will be cold strength, hot strength, oxidation resistance, hardness, density and electrical resistivity.

The main problem in hot pressing a bound material is that molten nickel squeezes out readily and erroneous results are thereby obtained. A bar therefore can be without porosity and still be below the theoretical density of the intended TiC-Ni mixture. Resulting from this uncertainty, scattering of data is prevalent and poor reproducibility is encountered.

2. Hydrogen Sintering

Hydrogen sintering will be used on the same powders as used for hot pressing. Suitable cold pressing conditions are being studied for the production of uniform green compacts. As cracks and laminations appeared in the final pieces, a new die was made to prevent them. Furthermore, the addition of a lubricant is being tried to aid in the preparation of suitable green compacts.

The green specimens will then be heated under a dry hydrogen atmosphere in a Megatherm induction heating unit. Once the proper heating conditions are found for the given powders, the same physical properties will be measured as in the case of hot pressing.

3. Vacuum Sintering

Cold pressed specimens, pressed under the same conditions as for hydrogen sintering, will be used for vacuum sintering. A high vacuum of about 5×10^{-5} mm pressure will be maintained once the sintering temperature is reached. At present, proper sintering temperatures and times at temperature are under investigation.

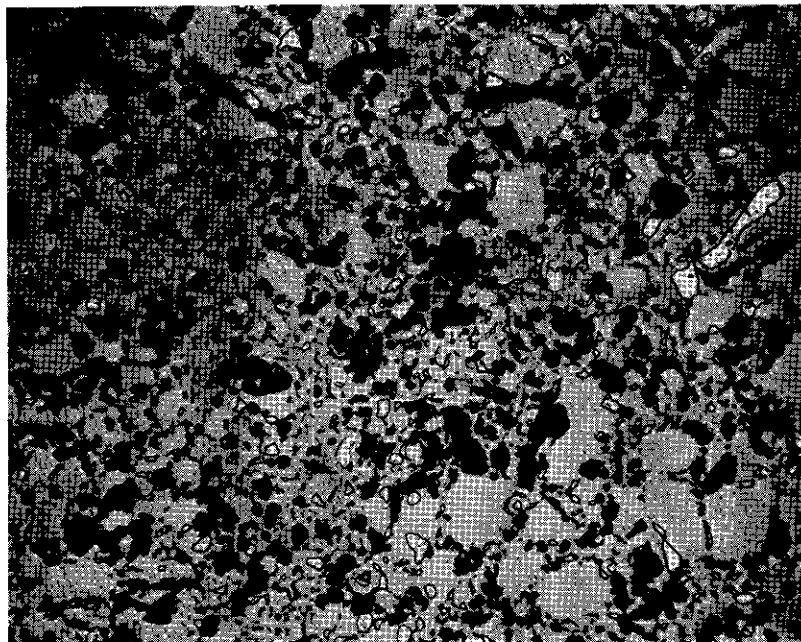

FIG. 14

OXALIC ACID ELECTROLYTIC ETCH
TiC (10% TiN) + 20% Ni

500X
HOT PRESSED 1700°C.

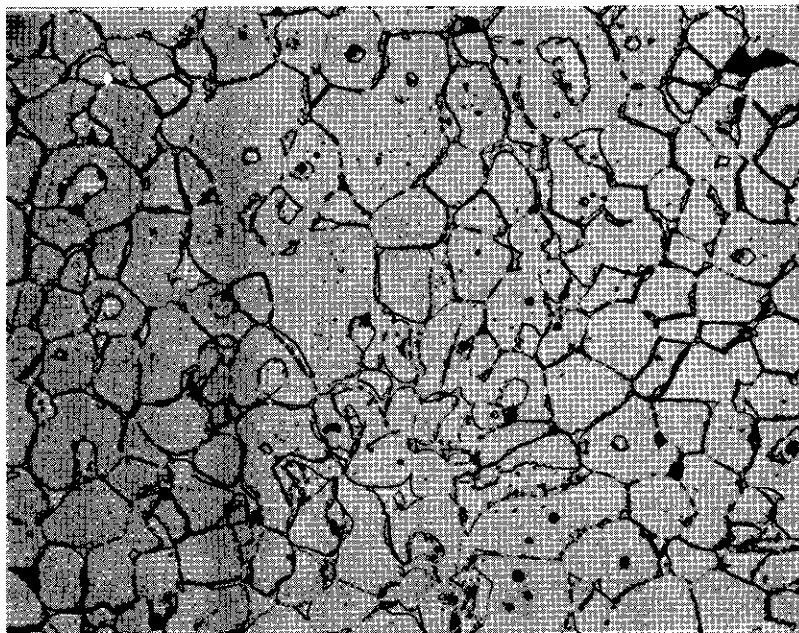

FIG. 15

ALK. SODIUM PICRATE ELECTROLYTIC ETCH
TiC (10% TiN) + 20% Ni

500X
HOT PRESSED 2000°C.

I. FUTURE WORK

Future work will be confined to titanium carbide base materials, as in the past.

A vacuum fusion apparatus for oxygen determinations recently acquired, will enable us to study in greater detail the influence of production variables on the oxygen content and the effect of the presence of oxygen on the physical properties of compacts (Figure 16). It will be attempted to determine whether oxygen occurs as a surface coating on the TiC particles or is in solid solution throughout the TiC. A similar investigation will be conducted on the role of nitrogen.

The influence of metallic impurities will be investigated by adding them in various quantities to Kennametal's TiC which is being used as base material. The effect of a nickel binder on the different titanium carbides at our disposal, and on the base material to which impurities have been added, will be studied. For first appraisal purposes, hot and cold transverse rupture testing will be used. An elevated temperature stress-to-rupture test will be employed for final correlations.

A special set-up for testing the oxidation resistance at elevated temperatures in moving air has been designed (Figure 17). Besides weight changes of the test piece (or powder), the carbon dioxide formed will be measured.

Means of purifying a low grade material by flotation, leaching or other means and compensation of the impurities by additions or special sintering techniques will be investigated.

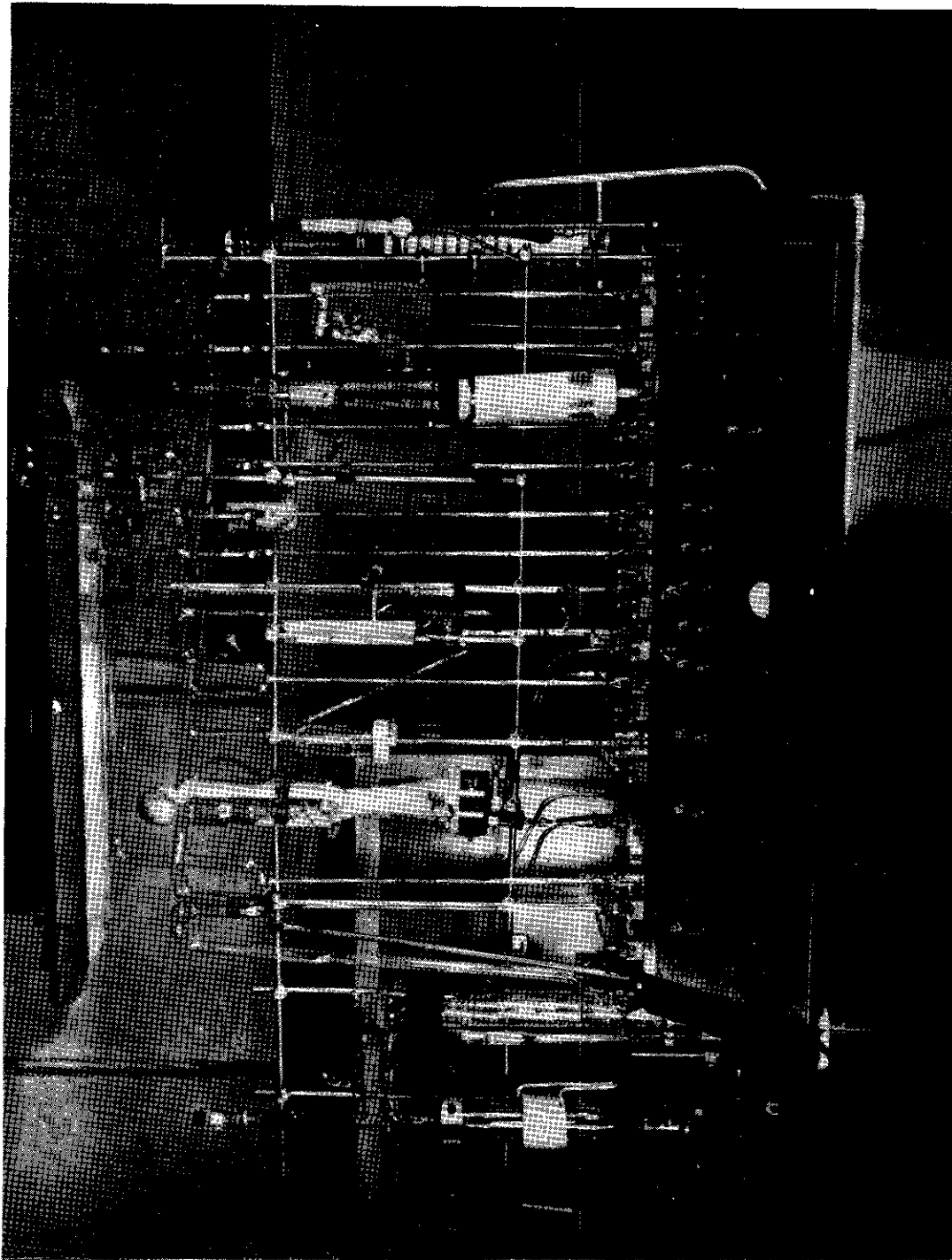

FIG. 16 VACUUM FUSION APPARATUS

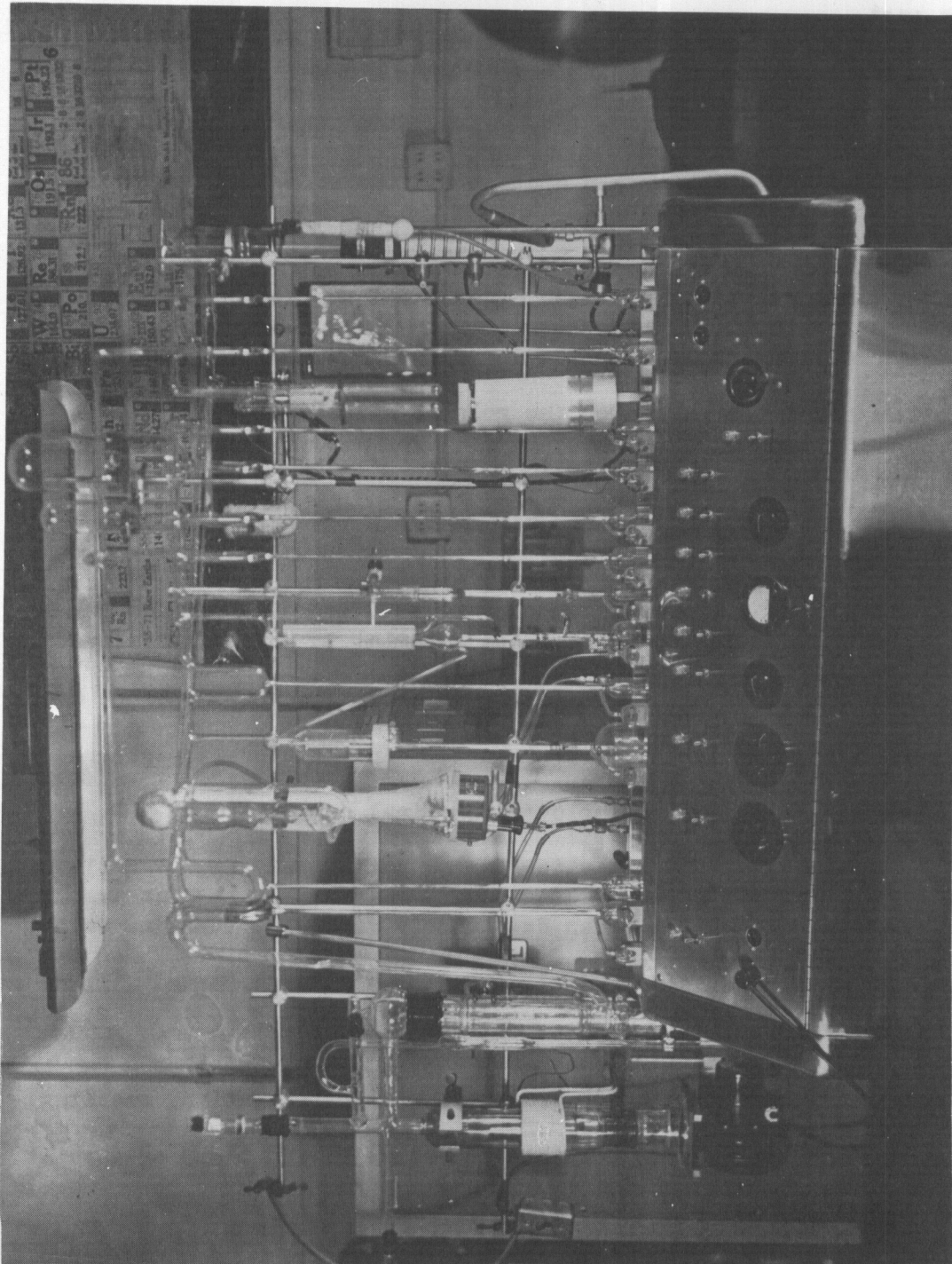
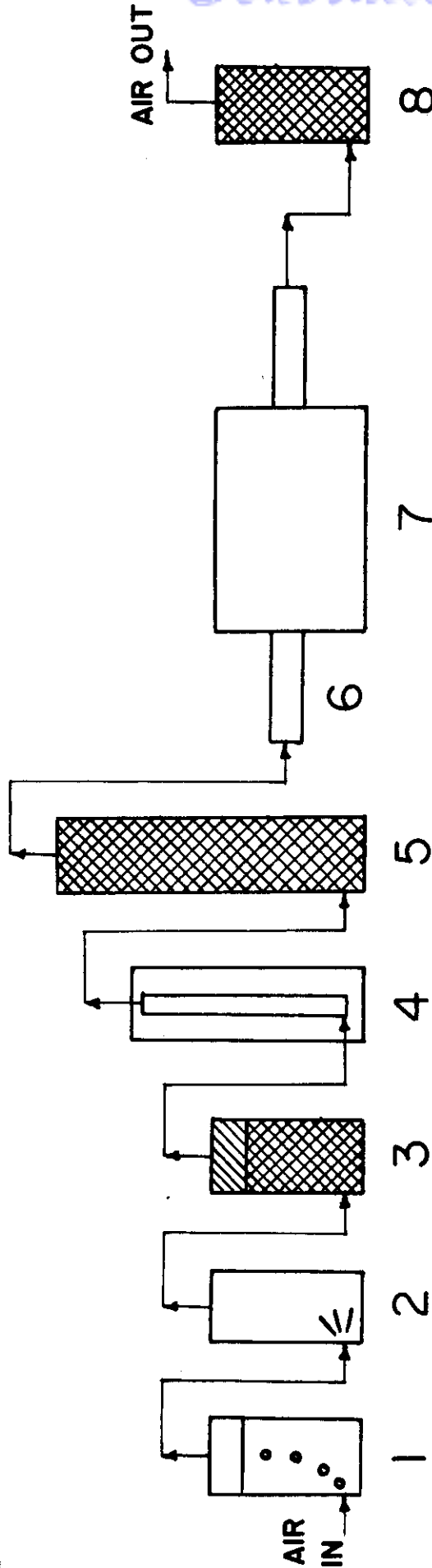

FIG. 16 VACUUM FUSION APPARATUS

CORROSION TEST IN AIR



- 1) SULPHURIC ACID TOWER
- 2) SULPHURIC ACID TRAP
- 3) H₂O AND CO₂ ABSORBENTS
- 4) FLOWMETER
- 5) SODA LIME TOWER
- 6) MULLITE TUBE (IMPERVIOUS)
- 7) HOSKINS RESISTANCE FURNACE
- 8) CO₂ ABSORPTION BULB

FIG. 17

Contrails

Infiltration experiments will be continued, especially in the direction of developing an infiltration test as a production control device for the evaluation of quality of TiC powders. The various powders have been compacted so far mostly by hot pressing. This will be continued, but more emphasis than before will be put on other techniques, as atmosphere and vacuum sintering. The influence of the various techniques on physical properties will be studied.

A special technique for the polishing and etching of specimens for microscopic examination is being worked on.

Most of the work done so far was done with Kennametal's TiC. After the procedures to be followed and the significance of the tests made with this material have been established, various other titanium carbides available will be investigated following the same pattern.