

AFFDL-TR-71-20
SUPPLEMENT I

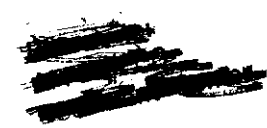

SURVIVABLE FLIGHT CONTROL SYSTEM
INTERIM REPORT NO. 1
STUDIES, ANALYSES AND APPROACH
SUPPLEMENT FOR CONTROL CRITERIA STUDIES

*Robert L. Kisslinger
Michael J. Wendt*

This document has been approved for public release. Its distribution is unlimited.

Contrails

FOREWORD

This report was prepared by McDonnell Aircraft Company, St. Louis, Missouri, 63166, under Air Force Contract F33615-69-C-1827, PZ05, "Development and Flight Test Demonstration of a Survivable Flight Control System." This contracted effort comprises a major portion of development under the Air Force Systems Command Program No. 680J, "Survivable Flight Control System (SFCS)." The work was administered under the direction of the Air Force Flight Dynamics Laboratory, Wright-Patterson Air Force Base, Ohio, 45433, by Major Robert C. Lorenzetti, Technical Manager.

The report covers work performed between July 1969 and May 1971.

Principal contributor to this supplement was Michael J. Wendl under the direction of Robert L. Kisslinger, Senior Project Dynamics Engineer. The authors wish to acknowledge the contributions of Jovo Djuric, Bruno Fajar and Roger H. Mathews to the information reported herein.

The manuscript was released by the authors in May 1971.

This technical report has been reviewed and is approved.

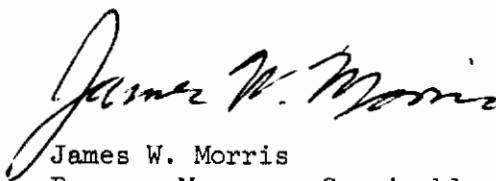

James W. Morris
Program Manager, Survivable Flight
Control System
Flight Control Division
Air Force Flight Dynamics Laboratory

Contrails

ABSTRACT

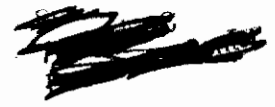

The Survivable Flight Control System (SFCS) Program is an advanced development program of which the principal objective is the development and flight test demonstration of an SFCS utilizing Fly-By-Wire and Integrated Actuator Package techniques. The studies and analyses conducted to date have sufficiently defined the system requirements to provide a definition of an approach to the implementation of the SFCS. The results of these studies and the definition of the approach are presented in the basic report. Details of the Control Law Development, and Hydraulic Power Actuation studies are presented in report supplements 2 and 3, respectively. The results of the Control Criteria studies are presented in this supplement 1.

With the introduction of highly augmented flight control systems and fly-by-wire systems such as the SFCS, increased concern over the adequacy of existing handling qualities specifications and performance criteria have been expressed. As a result, a control performance investigation has been conducted in an attempt to define both the longitudinal and lateral-directional short period performance criteria requirements, and determine if the control laws should be based on mission modes or tasks rather than the traditional short period handling qualities and control techniques.

Based on an extensive literature survey and a preliminary analysis, three candidate time history performance criteria were proposed. These were a normalized blend of pitch rate and normal acceleration, or C^* , for the pitch axis; a blend of roll rate and roll acceleration for the roll axis; and a blend of lateral acceleration and sideslip, or D^* , for the directional axis.

In order to verify the above candidate criteria, a six degree-of-freedom, fixed base, large amplitude piloted simulation was conducted. The basic approach was to define the minimum level of acceptable handling qualities by systematically evaluating various flight control system configurations and mission modes. Specifically, the following parameters were varied: time delays, time constants, nonlinearities, higher order effects, adverse or proverse yaw, and decoupled lateral-directional dynamics. In addition, the mission modes included low altitude high speed instrument tracking, weapon delivery (bomb run), reconnaissance, ground attack (strafing run) and air-to-air combat. The performance indicators and system effectiveness metrics included pilot comments, Cooper-Harper ratings, pilot effort index, time histories, and statistical data in the form of figures of merit, histograms and cumulative distributions.

Documentation data from the control performance analysis and simulation studies resulted in slight modifications to the candidate criteria boundaries. Moreover, the results of this study indicate that performance criteria, except possibly for specialized tasks such as air-to-air refueling and landing, need not be based on mission modes, but rather on the short period handling qualities presented in this report.

TABLE OF CONTENTS

<u>SECTION</u>		<u>PAGE</u>
I	Introduction and Summary	1
II	General	5
	1. Define SFCS Handling Quality Requirements	5
	2. Establish a Basis of Minimum Performance Requirements for Pilot Oriented Closed Loop Stability and Control	5
	3. Establish Three Axis Flight Path Control Performance Requirements for Gunnery and Bombing Aiming Accuracies	6
III	Background	7
	1. Mission Mode Fundamentals	7
	2. Literature Survey	7
IV	Supplier Meetings	9
	1. C* Criteria	9
	2. Lateral-Directional Criteria	9
	3. Supplier Comment Summary	9
V	Studies and Analysis	11
	1. Longitudinal	11
	2. Directional	16
	3. Lateral	26
	4. Weapon Delivery	27
VI	Simulation	33
	1. Crew Station Configuration and Hardware	33
	2. Computer Software Description	38
	3. Simulation Mission and Test Configurations	40
	4. Scoring and Data Recording	57
	5. Pilot Participation	62

Contrails

VII	Simulation Results	67
	1. Longitudinal Test Configurations	67
	2. Lateral-Directional Test Configurations	72
	3. Recommended Criteria	78
VIII	Conclusions and Recommendations	87
	1. Conclusions	87
	2. Recommendations	88
Appendix I	Literature Search	89
Appendix II	Normalized Lateral-Directional Equations	121
Appendix III	Tracking Equations	133
Appendix IV	Hybrid Simulation Software	147
Appendix V	Hybrid Computer Data Output	151
Appendix VI	Written Instructions Prepared for Simulation Pilots	165
Appendix VII	Simulation Pilots' Comments	169
	References	175

Contracts

LIST OF ILLUSTRATIONS

<u>FIGURE</u>		<u>PAGE</u>
1.	Phase II Program and Objectives - F-4 with Survivable Flight Control System	1
2.	SFCS Equipment Location	3
3.	C* Time History Traces for Category 1	13
4.	C* Time History Traces for Category 1	14
5.	Sideslip Excursion Limitations	17
6.	Dutch Roll Frequency and Damping Requirements (Class IV, Category A and B, Level 1)	19
7.	Sideslip Time History Envelope for Lateral Stick Force Input	20
8.	Sideslip Rate of Change Time History Envelope for Lateral Stick Force Input	21
9.	Directional Time History Criterion for Lateral Stick Force Input	25
10.	Roll Axis Time History Responses for Lateral Stick Force Input	29
11.	Time History Responses for Elevation Angular Tracking Error	31
12.	Visual Display Terrain Map	37
13.	Longitudinal Flight Control System	39
14.	Lateral-Directional Flight Control System	39
15.	Terrain Following/Avoidance Command Signals	43
16.	Special Trajectory Plot of Maneuvering Target	44
17.	Longitudinal Time History Response Traces for Time Delay Configurations	46
18.	Longitudinal Time History Response Traces for Prefilter Time Constant Configurations	47
19.	Longitudinal Time History Response Traces for Nonlinear Prefilter Configurations	49
20.	Longitudinal Time History Response Traces for Higher Order Prefilter Configurations	50

Contrails

21.	Lateral-Directional Time History Response Traces for Roll Time Constant Configurations with Aileron Step Input	51
22.	Lateral-Directional Time History Response Traces for Decoupled Configurations with Aileron Step Input	52
23.	Time History Response Traces for Decoupled Configurations with Rudder Step Input	53
24.	Lateral-Directional Time History Response Traces for Decoupled Configurations with Rudder Step Input	54
25.	Time History Response Traces for Adverse/Proverse Yaw Configurations with Aileron Step Input	55
26.	Lateral-Directional Time History Traces for Adverse/Proverse Yaw Configurations with Aileron Step Input	56
27.	Pilot Questionnaire	65
28.	Pilot Performance Data for Time Delay Configurations	68
29.	Pilot Performance Data for Prefilter Time Constant Configurations	70
30.	Pilot Performance Data for Nonlinear Configurations	71
31.	Pilot Performance Data for Higher Order Configurations	73
32.	Pilot Performance Data for Roll Time Constant Configurations	74
33.	Pilot Performance Data for Adverse/Proverse Yaw Configurations (o) and Decoupled Configuration (●) Plotted vs D_{\perp}^* Magnitude at $t = 1$ Second	76
34.	Pilot Performance Data for Adverse/Proverse Yaw Configurations (o) and Decoupled Configuration (●) Plotted vs D_{\perp}^* Magnitude at $t = 3$ Seconds	77
35.	Rating Summary - Cooper Harper Rating vs. Mission Mode for Parameters Investigated	79
36.	SFCS Pitch Axis Time History Criterion	80
37.	SFCS Pitch Axis Time History Criterion	81
38.	SFCS Roll Axis Time History Criterion	82
39.	SFCS Roll Axis Time History Criterion	83
40.	SFCS Yaw Axis Time History Criterion	85

Contents

41.	SFCS Yaw Axis Time History Criterion	86
42.	Normalized Equations of Motion Block Diagram	124
43.	F-4 Aircraft Dutch Roll Frequency Plot	128
44.	Coupling Parameter Relationship to Dutch Roll Frequency	129
45.	Sideslip Variation with Dynamic Pressure	130
46.	Sideslip Integration Gain Value	132
47.	Line of Sight Error Rates with Respect to Gunline Coordinates (x_{GL}, y_{GL}, z_{GL}) and the Line of Sight Coordinates (r, e, d)	134
48.	Aircraft's Body Rates with Respect to the Gunline Coordinates (x_{GL}, y_{GL}, z_{GL}) and the Body Axis (x, y, z) Coordinates	134
49.	Body Axis (x, y, z) Coordinates with Respect to the Earth Axis (x_E, y_E, z_E) Coordinates	136
50.	Wind Axis Coordinates (V, η, L) with Respect to the Body Axis Coordinates (x, y, z)	136
51.	Fire Control Mode	138
52.	Geometry of the Relative Velocity Vector	141
53.	Geometry of the Elevation and Lateral Tracking Errors with Respect to the Gunline	141
54.	Elevation Channel for Tracking Aerial Targets	143
55.	Lateral-Directional Channel for Tracking Aerial Targets	143
56.	Elevation Channel for Tracking Stationary Ground Targets	145
57.	Lateral-Directional Channel for Tracking Stationary Ground Targets	145
58.	Histogram (O) and Cumulative Distribution (*) Plots for LAHS	152
59.	Histogram (O) and Cumulative Distribution (*) Plots for WD	153
60.	Histogram (O) and Cumulative Distribution (*) Plots for RECON	155
61.	Histogram (O) and Cumulative Distribution (*) Plots for GA	157

Contrails

62.	Histogram (O) and Cumulative Distribution (*) Plots for CO	159
63.	Time History Response Data for LAHS, WD, RECON, GA and CO Modes of Operation (Recorder 1)	161
64.	Time History Response Data for LAHS, WD, RECON, GA and CO Modes of Operation (Recorder 2)	162
65.	Time History Response Data for LAHS, WD, RECON, GA and CO Modes of Operation (Recorder 3)	163

Contrails

LIST OF TABLES

<u>TABLE</u>		<u>PAGE</u>
I	Definition and Units for C* Equation	12
II	Short Period Frequency and Damping Values	15
III	Definition and Units for D* Equation	23
IV	Coupling and Modal Parameters	28
V	Simulated Mission	42
VI	Cooper-Harper Rating Scale	58
VII	Scoring Parameters Appearing on Printout Plots	61
VIII	Parameters Recorded on Analog Strip Charts	63
IX	Pilot Experience Summary	64
X	Control Performance Criteria References	90
XI	F-4 Aircraft Lateral-Directional Data	126
XII	Aircraft Physical Data	148

LIST OF ABBREVIATIONS AND SYMBOLS

ABBREVIATIONS:

CAL - Cornell Aeronautical Laboratory
CD - Cumulative Distribution
CDC - Control Data Corporation
CH - Cooper-Harper
CO - Combat (Air to Air)
DAC - Douglas Aircraft Company
FOM - Figure of Merit
GA - Ground Attack
LAHS - Low Altitude, High Speed
MAC - McDonnell Aircraft Company
MCAIR - McDonnell Aircraft Company
PC - Percentage
PEI - Pilot Effort Index
PIO - Pilot Induced Oscillation
RECON - Reconnaissance
SFCS - Survivable Flight Control System
STI - Systems Technology Incorporated
WD - Weapon Delivery

Contrails

SYMBOLS:

SYMBOL	DESCRIPTION	UNITS
$a_{x_{acc}}, a_{y_{acc}}, a_{z_{acc}}$	Acceleration components in body axis measured at accelerometer	g's
$a_{x_{cg}}, a_{y_{cg}}, a_{z_{cg}}$	Acceleration components in body axis measured at center of gravity	g's
$a_{x_p}, a_{y_p}, a_{z_p}$	Acceleration components in body axis measured at pilot station	g's
b	Wing span	ft
C_D	Dimensionless drag coefficient	
C_L	Dimensionless lift coefficient	
C_{l_p}	Dimensionless roll moment stability derivative due to roll rate	
C_{l_r}	Dimensionless roll moment stability derivative due to yaw rate	
C_{l_β}	Dimensionless roll moment stability derivative due to sideslip angle	
$C_{l_{\delta_a}}$	Dimensionless roll moment stability derivative due to aileron deflection	
$C_{l_{\delta_R}}$	Dimensionless roll moment stability derivative due to rudder deflection	
$C_{l_{\delta_{SP}}}$	Dimensionless roll moment stability derivative due to spoiler deflection	
C_M	Dimensionless pitching moment coefficient	
C_{m_q}	Dimensionless pitch moment stability derivative due to pitch rate	
C_{m_α}	Dimensionless pitch moment stability derivative due to angle of attack	
$C_{m_{\delta_s}}$	Dimensionless pitch moment stability derivative due to stabilator deflection	
C_{n_p}	Dimensionless yaw moment stability derivative due to roll rate	
C_{n_r}	Dimensionless yaw moment stability derivative due to yaw rate	

Contrails

$C_{n\beta}$	Dimensionless yaw moment stability derivative due to sideslip angle	
$C_{n\delta_a}$	Dimensionless yaw moment stability derivative due to aileron deflection	
$C_{n\delta_R}$	Dimensionless yaw moment stability derivative due to rudder deflection	
$C_{n\delta_{SP}}$	Dimensionless yaw moment stability derivative due to spoiler deflection	
C_{yp}	Dimensionless side force stability derivative due to roll rate	
C_{yr}	Dimensionless side force stability derivative due to yaw rate	
$C_{y\beta}$	Dimensionless side force stability derivative due to sideslip angle	
$C_{y\delta_a}$	Dimensionless side force stability derivative due to aileron deflection	
$C_{y\delta_R}$	Dimensionless side force stability derivative due to rudder deflection	
$C_{y\delta_{SP}}$	Dimensionless side force stability derivative due to spoiler deflection	
c.g.	Center of Gravity	
\bar{c}	Mean Aerodynamic Chord Length	ft
C^*	Longitudinal Response Criteria	g's
C_N^*	Normalized C^*	
\dot{C}^*	Derivative of C^*	g's/sec
C_2, C_3	Dimensional Constants	
D_1^*	Directional Response Criteria	deg
\dot{D}_1^*	Derivative of D_1^*	deg/sec
F_{Lat}	Lateral Stick Force	lbs
F_{Lon}	Longitudinal Stick Force	lbs
F_{Rud}	Rudder Pedal Force	lbs

Contrails

g	Acceleration due to gravity	ft/sec ²
H	Altitude of the aircraft	ft
h_i	Fraction during which a parameter magnitude falls in i-th interval	
I_X	Moment of inertia about X axis	slug/ft ²
I_{XZ}	Cross product moment of inertia in XZ plane	slug/ft ²
I_Y	Moment of inertia about Y axis	slug/ft ²
I_Z	Moment of inertia about Z axis	slug/ft ²
k	Ratio of "commanded roll performance" to "applicable roll performance requirement"	
$K_{E1}, K_{E2}, K_{E3}, K_{E4}$	Longitudinal prefilter gains	deg/lb
K_i	Magnitude of the input for lateral directional axis	lbs
K_f	Rudder flexibility constant	
K_0, K_1	ARI crossfeed gains	
K_2	Pitch rate gain constant	
K_3	Sideslip gain constant	
L_p	Rolling acceleration due to roll rate	sec ⁻¹
L_r	Rolling acceleration due to yaw rate	sec ⁻¹
L_β	Rolling acceleration due to sideslip angle	sec ⁻²
L_{δ_a}	Rolling acceleration due to aileron deflection	sec ⁻²
L_{δ_R}	Rolling acceleration due to rudder deflection	sec ⁻²
L_1, L_2	Longitudinal limits for nonlinear prefilter	lbs
$\bar{I}_r, \bar{I}_e, \bar{I}_d$	Line of sight coordinate axis unit vectors	
M	Mach number	

Contrails

m	Mass of the aircraft	slugs
N_{LF}	Normal load factor	g's
N_p	Yawing acceleration due to roll rate	sec ⁻¹
N_r	Yawing acceleration due to yaw rate	sec ⁻¹
N_β	Yawing acceleration due to sideslip angle	sec ⁻²
N_{δ_a}	Yawing acceleration due to aileron deflection	sec ⁻²
N_{δ_R}	Yawing acceleration due to rudder deflection	sec ⁻²
p	Roll rate, the angular velocity of airplane about X axis	rad/sec
PSS	Steady state roll rate	rad/sec
\bar{P}_N	Normalized roll rate transfer function	
q	Pitch rate, the angular velocity of airplane about Y axis	rad/sec
\bar{q}_{co}	Crossover dynamic pressure	lb/ft ²
\bar{q}	Dynamic pressure	lb/ft ²
R	Relative range	ft
r	Yaw rate, the angular velocity of airplane about Z axis	rad/sec
r,e,d	Orthogonal coordinates system with the line of sight as X axis	
S	Wing area	ft ²
T	Thrust	lbs
T_d	Damped period of Dutch Roll	sec
T_L	Longitudinal prefilter time constant	sec
T_N	Disturbed reticle lead computing optical sight system's time constant	sec
T_R	Lateral prefilter time constant	sec

Contrails

T_O	Roll axis modal time constant	sec
u	Velocity component of the airplane in the X axis	ft/sec
V	Total velocity of the airplane	ft/sec
V_{CO}	Crossover velocity	ft/sec
V_{Ax}, V_{Ay}, V_{Az}	Attacking aircraft's velocity components in body coordinates	ft/sec
V_E	Velocity component in earth axis in east direction	ft/sec
V_N	Velocity component in earth axis in north direction	ft/sec
$V_{r_r}, V_{r_e}, V_{r_d}$	Relative velocity components in the line of sight coordinates	ft/sec
T_{TX}, V_{TY}, V_{TZ}	Target velocity components in body coordinates	ft/sec
$V_{T_{X_E}}, V_{T_{Y_E}}, V_{T_{Z_E}}$	Target velocity components in earth coordinates	ft/sec
V, n, L	Wind axis coordinates	
v	Velocity component of the airplane in Y axis	ft/sec
w	Velocity component of the airplane in Z axis	
X, Y, Z	Body axis coordinates	
X_E, Y_E, Z_E	Earth axis coordinates	
X_{GL}, Y_{GL}, Z_{GL}	Gunline axis coordinates	
X_1, X_2, X_3	Lateral-directional normalized coupling parameters	
Y_p	Flight path angular velocity (lateral) due to roll rate (Dimensionless)	
Y_r	Flight path angular velocity (lateral) due to yaw rate (Dimensionless)	
Y_β	Flight path angular velocity (lateral) due to sideslip angle	sec ⁻¹
Y_{δ_a}	Flight path angular velocity (lateral) due to aileron deflection	sec ⁻¹

Contrails

Y_{δ_R}	Flight path angular velocity (lateral) due to rudder deflection	sec^{-1}
Y_{ψ}	Flight path angular velocity (lateral) due to roll angle	sec^{-1}
Y_{γ}	Flight path angular velocity (lateral) due to yaw angle	sec^{-1}
α	Angle of attack	rad
β	Sideslip angle	rad
β_{SS}	Steady state sideslip angle	rad
$\bar{\beta}_N$	Normalized sideslip angle transfer function	
γ_c	Flight path angle command	deg
γ_e	Elevation component of the angular orientation of the gunline with respect to the body axis	rad
Δ	Incremental change in the variable	
Δn_{y_p}	Incremental lateral load factor at pilot station	g's
Δn_{z_p}	Incremental longitudinal load factor at pilot station	g's
ΔT	Time delay	sec
Δ_a	Normalized aileron input transfer function	
$\Delta \beta_{max}$	Maximum sideslip excursion at the c.g.	rad
δ_a	Aileron deflection	rad
δ_r	Rudder deflection	rad
δ_s	Stabilator deflection	rad
δ_{SP}	Spoiler deflection	rad
ζ	Longitudinal prefilter damping ratio	
ζ_d	Dutch Roll oscillation damping ratio	
ζ_n	Longitudinal damping ratio of the short period oscillation	
ζ_o	Roll axis modal damping ratio	
ζ_1	Longitudinal prefilter damping ratio	

Contrails

θ	Pitch angle	rad
θ_E, θ_L	Elevation and traverse tracking errors	rad
θ_{ET}, θ_{LT}	Elevation and traverse angular components of the line of sight of the target with respect to the gunline axis	rad
$\theta_{ETL}, \theta_{LTL}$	Elevation and traverse angular components of the lead angle with respect to the gunline axis	rad
λ	Laplace operator	sec ⁻¹
ρ	Air density	slug/ft ³
σ	The sight's elevation channel stability constant	
τ_R	Rudder prefilter time constant	sec
τ_{LL}	Longitudinal prefilter high pass time constant	sec
ϕ	Bank angle	rad
ϕ_C	Bank angle command	deg
ϕ_{osc}/ϕ_{av}	Ratio of the oscillatory component of bank angle to the average component of bank angle	
$ \phi/\beta _d$	Ratio of amplitudes of the bank angle and sideslip angle envelopes in the Dutch Roll mode	
ψ	Yaw angle	rad
ψ_β	Phase angle of the Dutch Roll component of sideslip	rad
Ω_G	Angular velocity of the gunline	rad/sec
$\Omega_{G_r}, \Omega_{G_e}, \Omega_{G_d}$	Angular velocity components of the gunline in the line of sight coordinates	rad/sec
Ω_L	Angular velocity of the line of sight	rad/sec
$\Omega_{L_r}, \Omega_{L_e}, \Omega_{L_d}$	Angular velocity components of the line of sight in the line of sight coordinates	rad/sec
$\Omega_{L/C}$	Angular velocity of the line of sight vector to the attacking aircraft gunline	rad/sec
ω	Longitudinal prefilter undamped frequency	rad/sec

Contrails

ω_n	Undamped natural frequency of the short period oscillation	rad/sec
ω_{nd}	Undamped natural frequency of the Dutch Roll oscillation	rad/sec
$\omega_{rp}, \omega_{eq}, \omega_{dr}$	Components of the aircraft's body axis rotation in the line of sight coordinates	rad/sec
ω_0	Roll axis modal undamped frequency	rad/sec
ω_1	Longitudinal prefilter undamped frequency	rad/sec
N_z	Normal acceleration	g's
δ_e	Elevator deflection	rad

Contrails

xx

Approved for Public Release

SECTION I

INTRODUCTION AND SUMMARY

The Survivable Flight Control System (SFCS) Program is a flight control advanced development program being conducted primarily by MCAIR under contract to the Air Force Flight Dynamics Laboratory. The principal objective of this program is the development and flight test demonstration on an F-4 aircraft of a Survivable Flight Control System utilizing fly-by-wire and power-by-wire techniques.

Recent combat experience has shown that relatively minor damage, in the form of small arms fire, can result in aircraft loss due to loss of control. This is brought about by either hits in the hydraulic distribution system which drain the fluid, or hits which sever or jam the non-redundant mechanical flight control linkages. The power-by-wire concept of integrating electric motor driven hydraulic pumps with the surface actuator reduces system vulnerability through elimination of dependence on long exposed runs of hydraulic plumbing. The fly-by-wire concept of redundant and physically dispersed electrical control channels improves survivability by eliminating the single-failure points of the conventional mechanical control linkages.

The SFCS Program is being performed in two phases. Phase I, which included flight test evaluation of a Simplex integrated actuator package, has been completed and is documented in Reference 1. The Phase II program and objectives are illustrated by Figure 1, and include the development and flight test evaluation of a flight control system employing fly-by-wire and power-by-wire concepts.

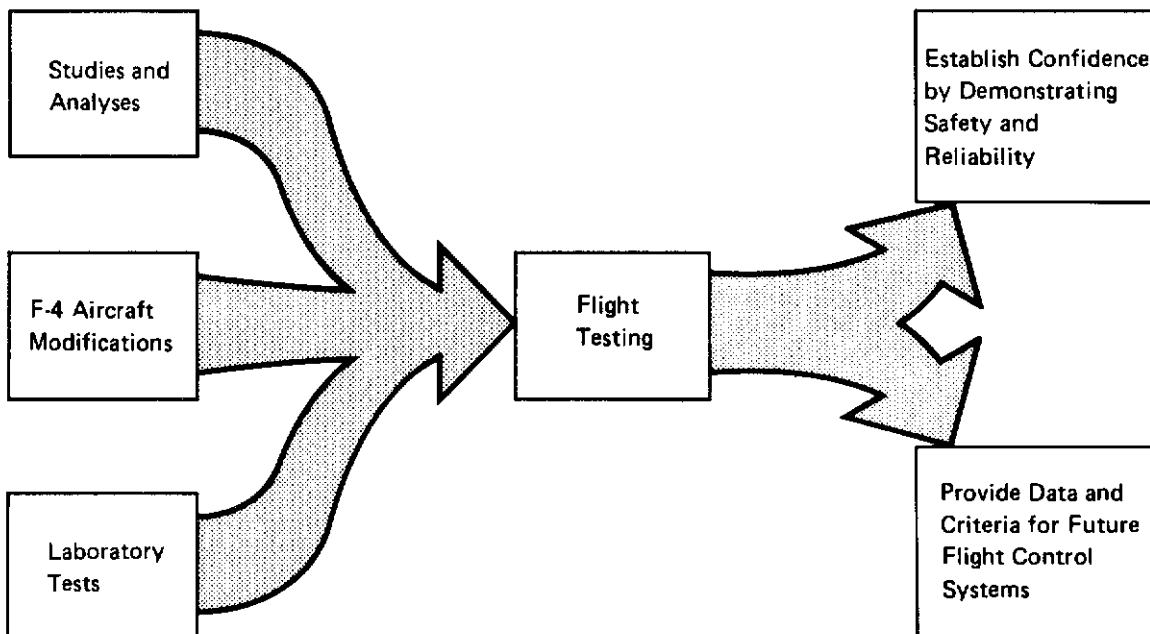

FIGURE 1
PHASE II - PROGRAM AND OBJECTIVES
F-4 WITH SURVIVABLE FLIGHT CONTROL SYSTEM

Contrails

Fly-by-wire (FBW) is a primary flight control system which uses an electrical signalling path to provide the desired aircraft response to pilot commands, without a mechanical connection between the cockpit controller and the control surface actuator. It can incorporate aircraft motion sensors such that aircraft motion, rather than control surface position, is the controlled variable. To be accepted by the aerospace industry as more than a research tool, the reliability of the FBW system must meet or exceed the reliability of the mechanical system it is replacing, while showing advantages in other areas. The benefits foreseen for an FBW system include:

- o Enhanced survivability
- o Superior aiming, tracking, and weapon delivery
- o Reduced pilot workload
- o Flight control design and installation savings
- o Decreased cost of ownership
- o More airframe design freedom

Power-by-wire (PBW) is the transmission of power from the aircraft engines to the flight control surface actuators by electrical rather than hydraulic means. Hydraulic power is generated by electric motor driven hydraulic pump(s) integral to the actuators. Power-by-wire equipment has been called "integrated actuator packages" in this country, and simply "packaged actuators" in England.

The redundancy and dispersion of a fly-by-wire system and the get-home-and-land capability provided by an actuator with an emergency-only electric motor driven pump could be combined to provide a measurable improvement in flight control survivability. An F-4 Simplex Actuator Package with this emergency-only PBW capability was successfully flight tested in Phase I of the SFCS Program, with results reported in Reference 1. However, a survivable flight control system requires use of power-by-wire integrated actuator packages which are capable of full-time operation independent of the aircraft central hydraulic systems and their exposed plumbing. The Survivable Stabilator Actuator Package (SSAP) to be flight tested in Phase IIC of the SFCS Program will be a duplex PBW actuator capable of full-time operation throughout the F-4 flight envelope. The SSAP will be controlled by the fly-by-wire system installed and flight tested in Phases IIA and IIB of the program.

The location of the fly-by-wire system components, the SSAP, and the other SFCS equipment in the F-4 test aircraft is shown in Figure 2.

The results of the SFCS studies and analyses to date, and the definition of the SFCS approach are presented in the basic report. The details of the Control Criteria Studies are presented in this supplement. The details of the Control Law Development, and Hydraulic Power and Actuation Studies are presented in report supplements 2 and 3, respectively.

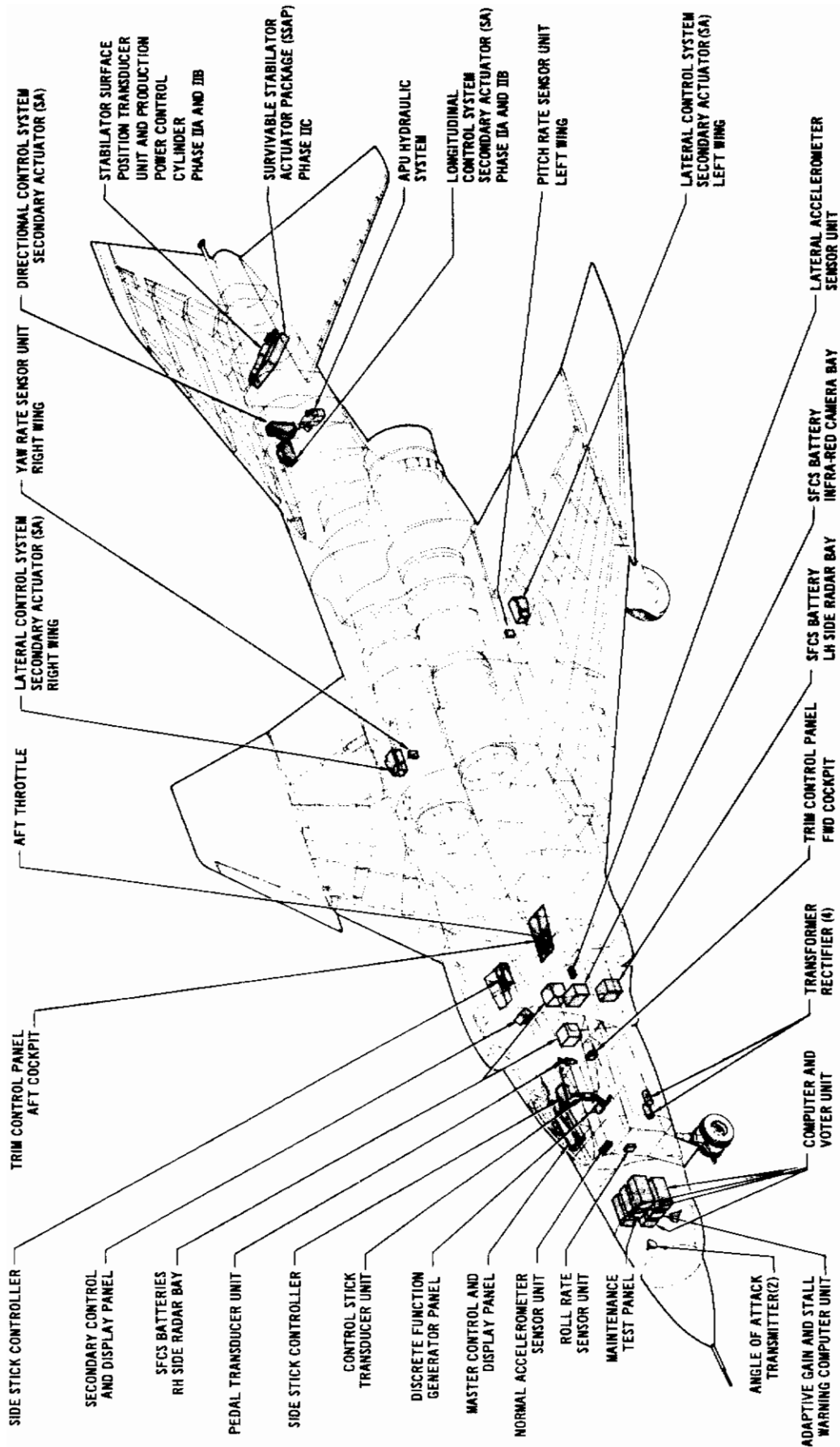

FIGURE 2
SFCs EQUIPMENT LOCATION

Contrails

SECTION II

GENERAL

Past programs for development of longitudinal and lateral-directional handling qualities have been directed toward establishing limiting values of traditional performance parameters (frequency, damping, time constants, etc.) which pilots feel are consistent with desired levels of precision and control during maneuvering flight. The work performed to date, which has been used to update applicable military specifications has been directed mainly toward the specification of handling qualities for aircraft which did not include the use of aircraft motion feedbacks in the primary flight control mode. With the introduction of highly augmented flight control systems and fly-by-wire systems such as the SFCS, increased concern over the adequacy of existing specifications and performance criteria has been expressed. As a result, a control performance investigation has been conducted in an attempt to define short period performance criteria requirements for the SFCS. Performance criteria which are expressed in the time domain and functionally combine the high and low speed transient characteristics desired by the pilot were investigated and results of the associated effort are presented in this report. Applicability to future FBW designs was one of the objectives of the study effort and it was determined that if the formulated criteria is not explicitly dependent on traditional airframe parameters, its use could be applicable to advanced designs. Multi-loop systems of this type will cause significant masking of the basic airframe characteristics and further divorce the fighter aircraft transient response characteristics desired by the pilot for specific inputs, from conventional control surface usage. Since candidate criteria developed during this investigation are an expression of fighter pilots' desired handling quality requirements, and are not dependent on airframe characteristics or flight control system mechanization, they are applicable to future SFCS designs. The specific goals and objectives of the investigation were to:

1. DEFINE SFCS HANDLING QUALITY REQUIREMENTS BY INVESTIGATING:
 - a. to what degree C* handling qualities criteria is compatible with the required mission loop closures
 - b. how higher order and nonlinear characteristics affect application of C* criteria
 - c. if lateral-directional handling and flying qualities can be incorporated into a new criterion
 - d. if control laws should be based upon mission modes or tasks rather than the traditional short period handling qualities and control techniques
 - e. if interaxis coupling is desirable and if so to what degree.
2. ESTABLISH A BASIS OF MINIMUM PERFORMANCE REQUIREMENTS FOR PILOT ORIENTED CLOSED LOOP STABILITY AND CONTROL.

Contrails

3. ESTABLISH THREE AXIS FLIGHT PATH CONTROL PERFORMANCE REQUIREMENTS FOR GUNNERY AND BOMBING AIMING ACCURACIES BY:
 - a. analytically defining, formulating and studying the parameters which significantly affect tracking stability and weapon delivery precision.
 - b. evaluating compatibility of C* criteria and lateral-directional criteria with mission tasks.

SECTION III

BACKGROUND

1. MISSION MODE FUNDAMENTALS

Mission mode dynamics can be considered in terms of an equivalent block diagram in which three serial elements consisting of the weapon platform (airframe and SFCS), the mission mode outside geometry with inside displays, and the pilot, form a "closed loop" which functionally performs the mission mode tasks such as tracking, terrain following, precision flying, etc. Successful accomplishment of these tasks involves adequate stability and speed of response of the closed loop dynamics which in turn places individual requirements on each of the three serial elements. In the past, some weapon systems which did not have adequate displays and/or weapon platform dynamics, have relied heavily on pilot adaptability and skill for closed loop compensation and accomplishment of the stated mission objectives. This technique has a tendency to increase pilot work and also requires extensive training of pilots to perform specific tasks to required accuracy. Current interest in mission mode concepts is related to the relaxation of superior pilot skill requirement with more emphasis on improvement of remaining two elements in the closed loop. The subject of this report addresses itself to this closed loop problem and utilizes analysis tools such as the Improved Model for Aerial Gunnery Effectiveness (IMAGE) computer program and hybrid man-in-the-loop simulation for investigation of platform dynamics to establish candidate criteria in the time history domain.

2. LITERATURE SURVEY

The performance criteria investigation was initiated with a literature survey of available information to determine the applicability of subject results toward the accomplishment of the outlined objectives. It was found that fighter aircraft handling quality characteristics as provided by standard flight control systems were adequately covered in the literature. In comparison, a noticeable absence was evident of information pertaining to highly augmented aircraft flight control systems and their handling and flying characteristics. Only a few articles discussed non-traditional types of criteria such as those formulated in frequency response or time history response domains.

Appendix I presents a bibliography of articles which were reviewed during the course of this study and a few are presented in summary form. A number of articles were especially helpful in the area of statistical approaches and test procedure to employ in order to obtain valid results.

In order to establish a basis of minimum performance requirements for pilot oriented closed loop stability and control, MIL-F-8785B, Reference (2), and the associated USERS REFERENCE GUIDE, Reference (3), were reviewed to determine applicability to highly augmented aircraft flight control systems such as the SFCS. It was found that the informational content of this specification is applicable as a guide towards SFCS design and development but the classical terminology as presented in

Contrails

Reference (2) is somewhat ambiguous. It is felt that system response characteristics (response to specific inputs or multiple input combinations expressed in the frequency or time domain) could be an additional means of specifying effective requirements and should be considered for use during the SFCS program.

SECTION IV

SUPPLIER MEETINGS

A series of meetings was held with industry personnel and comments were obtained during discussions with Avionic suppliers prior to SFCES procurement. The main purpose of these meetings was to benefit from experience gained by the suppliers in the area of handling qualities during past programs in which new concepts of control were mechanized and investigated. Items discussed included:

1. C* CRITERIA

Supplier experience with the applicability of the C* criterion was explored to determine results obtained and the degree to which mission mode tasks can be accomplished with a mechanization that provides a response which meets C* criteria. Areas of discussion included the C* envelopes of acceptability in terms of delay time, initial transient, and frequency/damping characteristics. Inquiries were made to determine if the suppliers had performed studies to show the effect of higher order terms and nonlinearities on the pilot feel and the precision flying capability.

2. LATERAL-DIRECTIONAL CRITERIA

Concepts of inter-axis decoupling and the desired lateral-directional handling quality characteristics were discussed with the suppliers. It was indicated that an attempt was to be made to formulate a criterion in the time domain which is useable throughout the flight envelope.

3. SUPPLIER COMMENT SUMMARY

Discussions with 15 individual representatives from five leading suppliers helped generate the following list of comments and general conclusion relative to the subject matter involved:

- a. At least one supplier felt that the C* criterion concept is of very little value. The main objection stated was that the criterion is inherently not unique. Some adverse characteristics in one C* term can be averaged out by another term through addition, to yield an apparently acceptable C* response that does not provide acceptable handling qualities.

This conclusion was based in large part on theory and had not been substantiated through either simulation or flight test.

- b. Three out of five suppliers felt that the C* criterion complements the SFCS concept of design and as such is very applicable to this type of control. One supplier had successfully used the criterion for development of a high authority flight control system which is currently being flight tested. In this case, the criterion was applicable with the added constraint that specified minimum values

Contrails

of short period frequency and damping were met or exceeded with the augmented system. In general, these suppliers all felt that the C* criterion should be constrained in some manner to make it more useful for general application to fighter aircraft flight controls.

- c. From available information, past development programs depended heavily on pilot satisfaction of handling qualities in the roll and yaw axes. At least one supplier indicated that the feasibility of use of a roll axis time history criterion has been established. Most suppliers felt that a need exists for an equivalent directional time history criterion. Current practice indicates that pilots desire zero "ball" movement during turning maneuvers.
- d. One supplier felt that there is some trade-off benefit to mechanizing a separate configuration for air-to-air and another configuration for air-to-ground. This could be accomplished by automatic or manual switching of the feedback gain parameters to achieve the desired flight path characteristics for a particular mode.

In general, the discussions with suppliers indicated some reservations of routine application of C* criterion. These are due in large part to the unknown effect on pilot ratings of a number of response abnormalities which would not violate the C* criterion. In addition, no lateral-directional counterpart of the longitudinal C* criterion is presently in use by the suppliers. All discussions and information presented by suppliers was helpful in formulation of candidate criteria used during man-in-the-loop testing with pilots during six-degree-of-freedom fixed base simulation.

SECTION V

STUDIES AND ANALYSIS

The problem of generating meaningful performance criteria is one of determining what levels and types of handling qualities are required by pilots and how they help accomplish his mission mode tasks. The pilot determines if a particular flight control system provides the desired performance improvement, by assessment of aircraft dynamic motion resulting from command and disturbance inputs. It can be shown that pilots are quite sensitive to three axis motion cues and utilize these, in large part, to fly the aircraft. Studies conducted during the course of the SFCS program and described in these sections are based on the assimilation of the appropriate motion cues into meaningful criteria which provide that the transient flight dynamics are acceptable to the pilot. The C* criterion is an example of specifying short period handling qualities in terms of aircraft parameters familiar to the pilot. The concept implicitly includes the traditional short period frequency and damping requirements and is more general in its application. Current design philosophy for fly-by-wire and highly augmented flight control systems inherently includes sensor feedback and electronic compensation to provide a response which will meet the C* criterion. MCAIR pilots have endorsed the general concept of fly-by-wire and feel that the studies described here will help in the development of a superior weapon system.

1. LONGITUDINAL

The definition of the C* expression as used during the SFCS analysis and studies is shown in Table I. This equation is equivalent to Equation 1, page 12, Reference (4), which can be written as,

$$\frac{C^*}{\delta_e} = K_a \frac{N_z}{\delta_e} + K_b \frac{\dot{\theta}}{\delta_e} + K_c \frac{\ddot{\theta}}{\delta_e}$$

where the symbols K_a , K_b , and K_c are dimensional constants. The $\ddot{\theta}$ term in above equation represents normal acceleration increment at the pilot station caused by the moment arm from vehicle center-of-gravity. In the C* equation of Table I, the contributions due to N_z and $\ddot{\theta}$ are lumped into one term (Δn_{zp}) which represents the total normal acceleration sensed at the pilot station. On page 14 of this reference, it is stated that "The lower portion of the C^*/δ_e envelopes have been modified for the first few tenths of a second to account for the effect of forward transmission dynamics (actuators, mechanical linkages, shaping networks, etc.)." In order to establish a quantitative interpretation of this statement, Equation 9 of this reference,

$$\frac{C^*}{\delta_e} = \left(\frac{\omega_n^2}{177.2} \right) \frac{(\lambda + 61.1)(\lambda + 2.90)}{\lambda^2 + 2\zeta_n \omega_n \lambda + \omega_n^2}$$

was used to generate time history response traces for unity step inputs. The above transfer function equation was programmed on a MCAIR analog computer and short period damping and frequency requirements from Reference 4, page 3, Category 1 were tabulated (Table II) and used to generate the time history response traces shown in Figure 3 and 4 for unity step

**TABLE I
DEFINITION AND UNITS FOR C* EQUATION**

● Definition

$$C^* = \Delta n_{z_p} + K_2 q$$

Δn_{z_p} = Incremental Normal Load Factor at Pilot Station

q = Pitch Rate

$K_2 = C_2 V_{c_0}$ Pitch Rate Gain Constant

C_2 = Dimensional Constant

V_{c_0} = Crossover Velocity

● Units

C*	Δn_{z_p}	q	C ₂	
			Value	Units
g's	g's	rad/sec	$\frac{1}{32.2}$	$\frac{g's \cdot sec^2}{ft}$
		deg/sec	$\left(\frac{1}{32.2}\right) \left(\frac{1}{57.3}\right)$	$\frac{g's \cdot sec^2}{ft-deg}$
ft/sec ²	ft/sec ²	rad/sec	1.0	Radians
		deg/sec	$\frac{1}{57.3}$	$\frac{rad}{deg}$

● Assumption

$$V_{c_0} = 400 \text{ ft/sec}$$

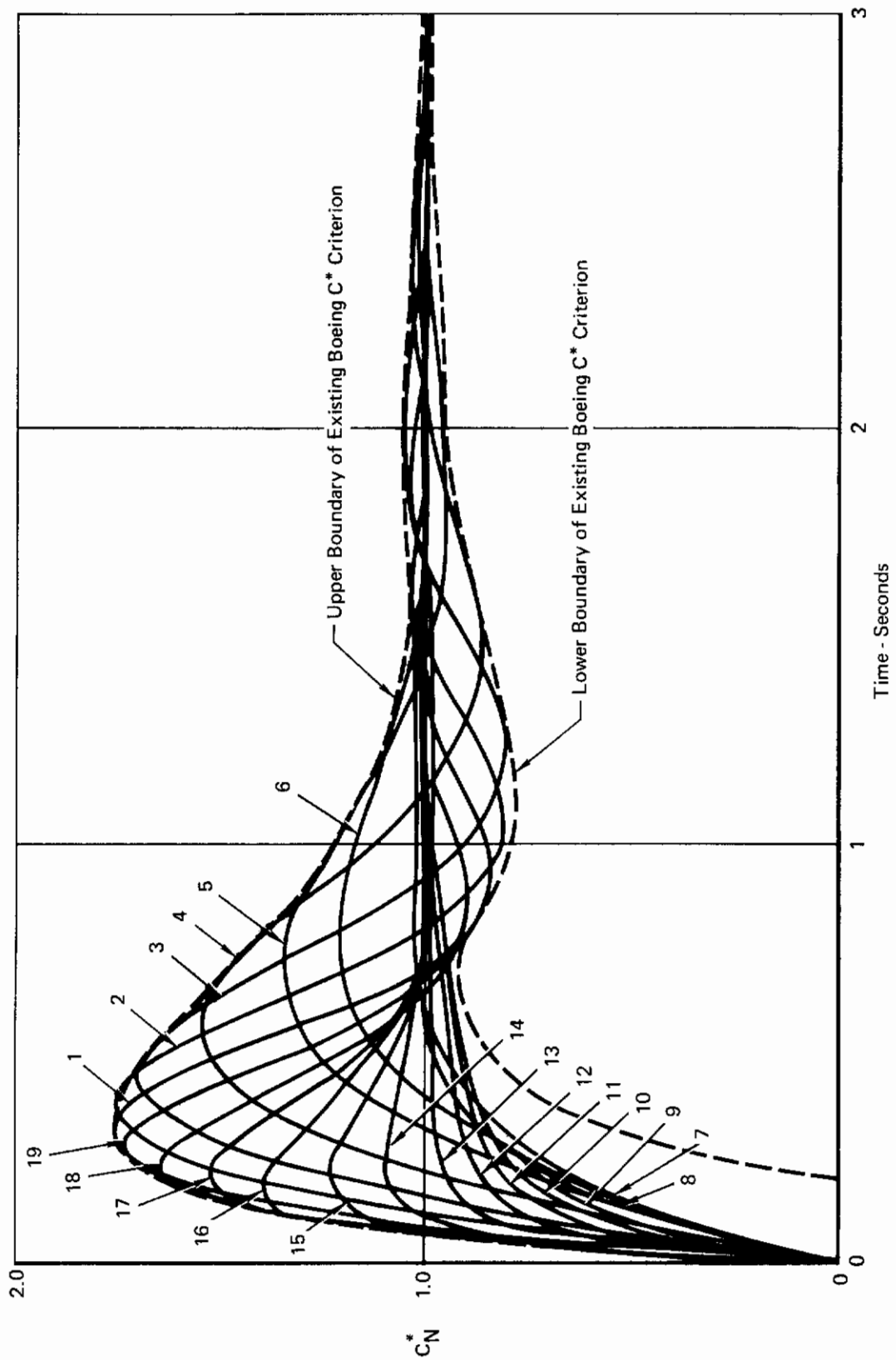

FIGURE 3
C* TIME HISTORY TRACES FOR CATEGORY 1

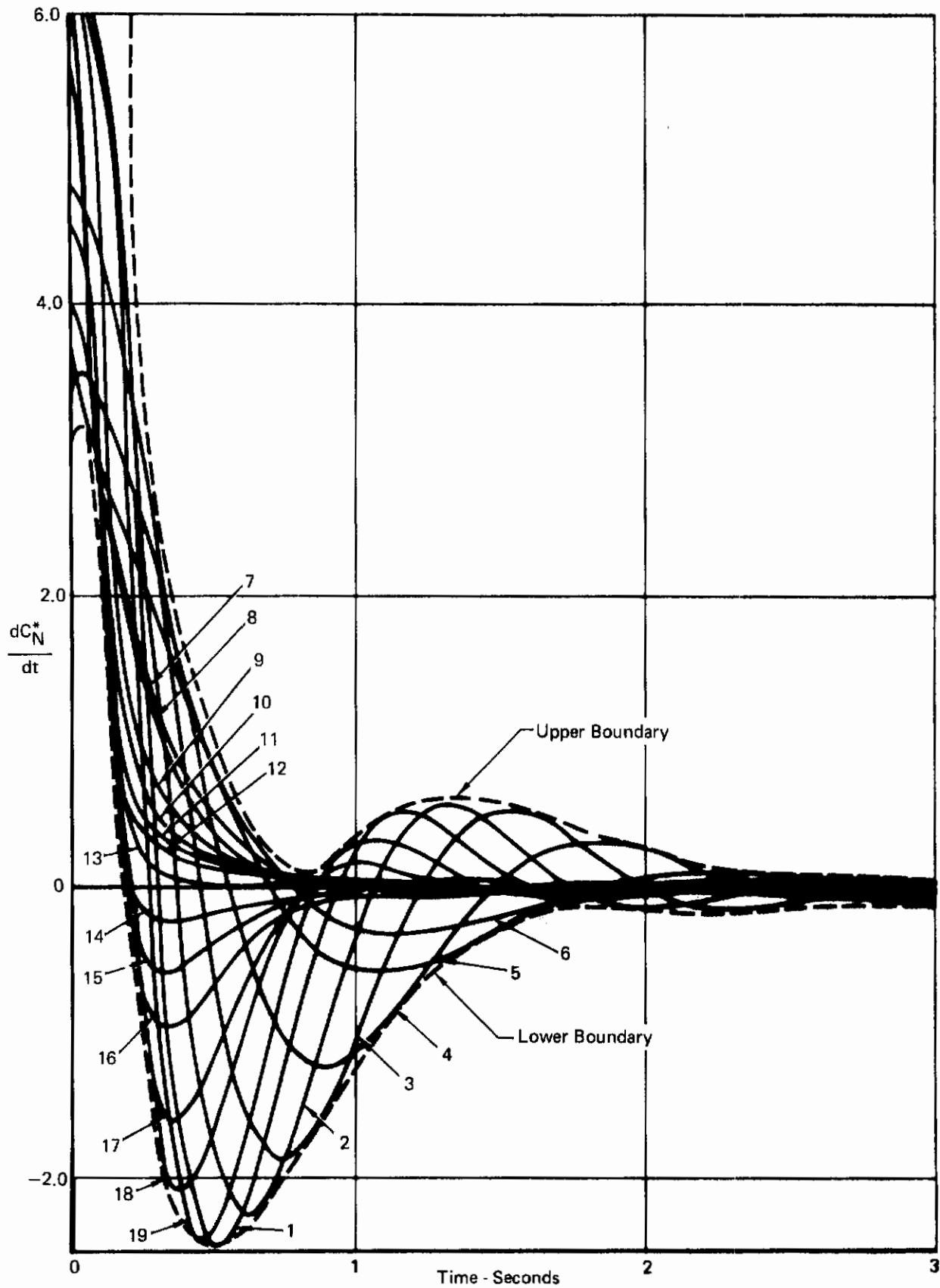

FIGURE 4
 \dot{C}^* TIME HISTORY TRACES FOR CATEGORY 1

**TABLE II
SHORT PERIOD FREQUENCY AND DAMPING VALUES**

Configuration Number	ζ_n	ω_n	Configuration Number	ζ_n	ω_n
1	0.45	5.66	11	1.45	5.66
2	0.40	5.02	12	1.50	6.28
3	0.37	4.40	13	1.45	6.91
4	0.40	3.77	14	1.30	7.54
5	0.50	3.27	15	1.12	7.60
6	0.60	3.14	16	0.92	7.54
7	0.88	3.45	17	0.77	7.22
8	1.00	3.77	18	0.65	6.91
9	1.20	4.40	19	0.53	6.28
10	1.35	5.02			

inputs. As can be seen from Figure 3, the periphery of the time history response traces generated in this manner is reasonably well defined with the existing C* criteria in all areas except on the lower boundary. Here there is a significant difference, since the criteria envelope allows a transportation lag of as much as 0.20 seconds. Since previous investigations have shown this amount of lag to be significant, it was decided to investigate this characteristic during the simulation phase and determine its effect on pilot performance.

Concern over the adequacy of the C* criterion and its routine application has resulted in an analysis to determine the compatibility of nonlinear dynamics and higher order effects with the C* concept. The existing criterion allows a lightly damped, high frequency mode superimposed on the dominant response mode which might be contained in the acceptable region but which is otherwise unacceptable due to the low stability margin which is causing the low damped oscillation. In a similar manner, a highly nonlinear response might meet the C* envelope and yet be undesirable when present in the aircraft. To circumvent these difficulties, several methods were investigated and one was selected as having the most promise for use as a criterion. Its formulation is based on constraining the C* rate of change response in an acceptable manner and is to be used in addition to the existing C* response criterion.

The proposed C* rate of change criterion shown in Figure 4 was generated by establishing a boundary line around the periphery of the differentiated response traces resulting from,

$$\frac{dC^*}{dt} \approx \left(\frac{\lambda}{\lambda/k_5 + 1} \right) C^*$$

where $k_5 = 1000$ and frequency and damping values used are given in Table II. Selection of $k_5 = 1000$ is a convenient value which results in an acceptable approximation of the above high pass transfer function to a pure differentiation required for generating the C^* rate of change time history responses as shown in Figure 4. This envelope of acceptability is expressed in normalized C^* units per second for the ordinate and in "real time" seconds for the abscissa.

2. DIRECTIONAL

The need for establishing time domain criteria for the roll/yaw axis is based in part on the strong correlation of pilot rating and flight sensitivity to lateral-directional aircraft motion which occurs in the time domain. Pilot comments and discussions on methodology of providing ratings indicates that classical terms such as frequency, damping, and time constant parameters can be relatively abstract to pilots who, instead, place strong emphasis on aircraft motions and how they vary during flight. This is further evident when it is realized that pilot unfamiliarity with engineering terminology apparently does not detract from the capability to recognize undesirable characteristics, formulate opinions on their severity and express these in standard terminology.

Design engineers who have used the traditional handling quality parameters to date, have been more constrained in recent years, in providing adequate answers because aircraft and flight control system response characteristics have deviated from simple representation and evaluation data presented to show compliance with military requirements had to be approximated to fit the prescribed format. These shortcomings can be alleviated if time history response data related to specific input commands are used for comparison with applicable criteria.

Additional need for time history criteria is also evident in computerized design techniques which employ optimal or modern control techniques to establish compensation and control law definition to satisfy a prescribed cost functional which contains the short period handling quality criteria as function of time.

Lateral-directional studies were directed toward establishing a separate time history criterion for the roll axis and yaw axis. The intent was to define the transient response characteristics in each axis due to a lateral step command input from the pilot.

a. Directional Response to Aileron Command Input

MIL-F-8785B requirements for maximum sideslip excursion occurring during aileron step command inputs include a definition of limits for $\Delta\beta_{MAX}/k$ as shown in Figure 5, which are not to be exceeded for various operating levels and phases. The parameter $\Delta\beta_{MAX}$ is defined as the maximum sideslip excursion at the c.g. occurring within two seconds or one-half period of the Dutch Roll, $(T_d/2)$, whichever is greater, for a step aileron control command. Since preliminary SFCS designs show that the $(T_d/2) = 2.0$ second (constant) requirement generally predominates, the "damped period of Dutch Roll" equation appearing on page 68, Reference 2,

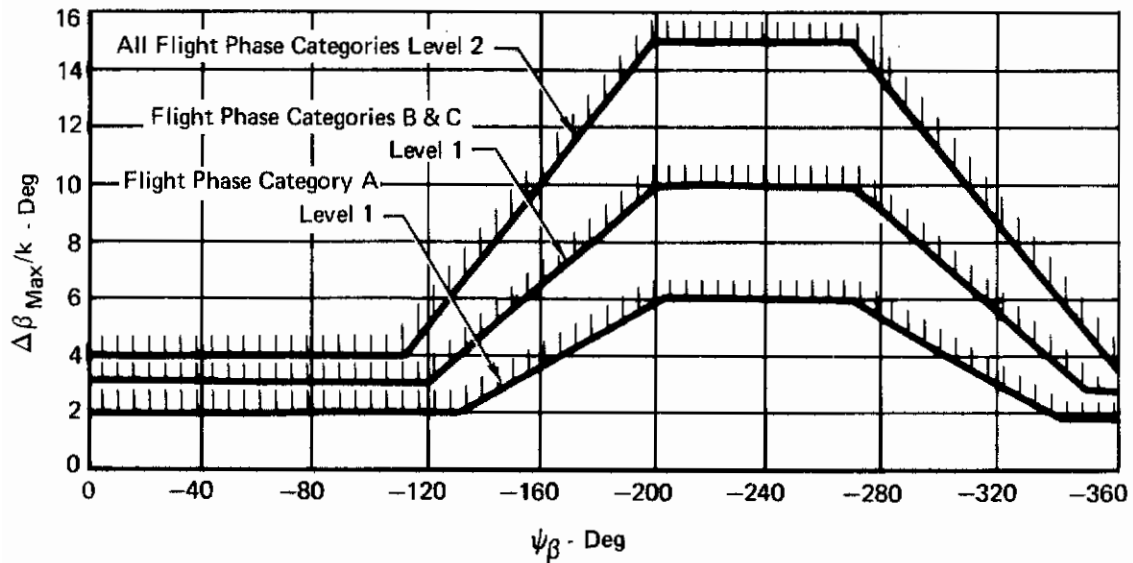

FIGURE 5
SIDESLIP EXCURSION LIMITATIONS

$$\omega_d = \frac{\pi}{\left(\frac{T_d}{2}\right) \sqrt{1 - \zeta_d^2}}$$

was used as a means of superimposing this requirement on a plot generated from the minimum Dutch Roll frequency and damping data (Table VI, page 23, Reference 2) for comparison of the assumptions inherent in the use of a constant value for $T_d/2$. Figure 6 shows the combination plot and identifies the various areas of acceptability for level 1, categories A and B operation. Category C was not included in the analysis effort, and the study results discussed here are not intended to be applicable to the landing and take-off flight conditions. Emphasis on selected mission modes described in this report resulted in program software limitations that did not allow testing at the terminal flight conditions for which adequate data is available from previous investigations. From the above figure, it can be seen that only a small part of the acceptable area is eliminated if it is assumed that all values lie above the line for $(T_d/2) = 2.0$. This rationalization and the fact that highly augmented systems can help provide frequencies which fall in the upper area, makes the assumption a reasonably valid one.

The above plot, Figure 5, for $\Delta\beta_{MAX}/k$ can be made independent of the "coordination" parameter ($\psi\beta$), if a constant value of $\Delta\beta_{MAX}/k = 2.0$ is used. A direct mapping in the time domain follows with point A of Figure 7 reflecting these two data point values. The lines which intersect point A and form the acceptable area for sideslip due to aileron step command inputs were established "a priori" in the following way,

- Line 1 - The somewhat pessimistic assumption of $\Delta\beta_{MAX}/k = 2.0$ is offset by a maximum allowable deviation of $\beta/k = \pm 2$ during $t < 2.0$ seconds.
- Line 2 - An average value of one degree per second is assumed as the average deviation for $t \geq 2.0$ seconds

In order to eliminate undesirable characteristics such as those generated by higher order and nonlinear dynamics, it is necessary to add an associated rate of change criterion to the above response criterion. The resultant plot is shown in Figure 8, and together they represent the equivalent time history boundaries for the MIL-F-8785B specified sideslip excursion with aileron step command inputs.

b. D* Concept

From discussions with electronic equipment suppliers during the initial phase of the SFCS program, it was learned that in at least one development program lateral acceleration at the pilot station was used as a criterion parameter for evaluating directional response characteristics due to aileron inputs. This coupled with comments

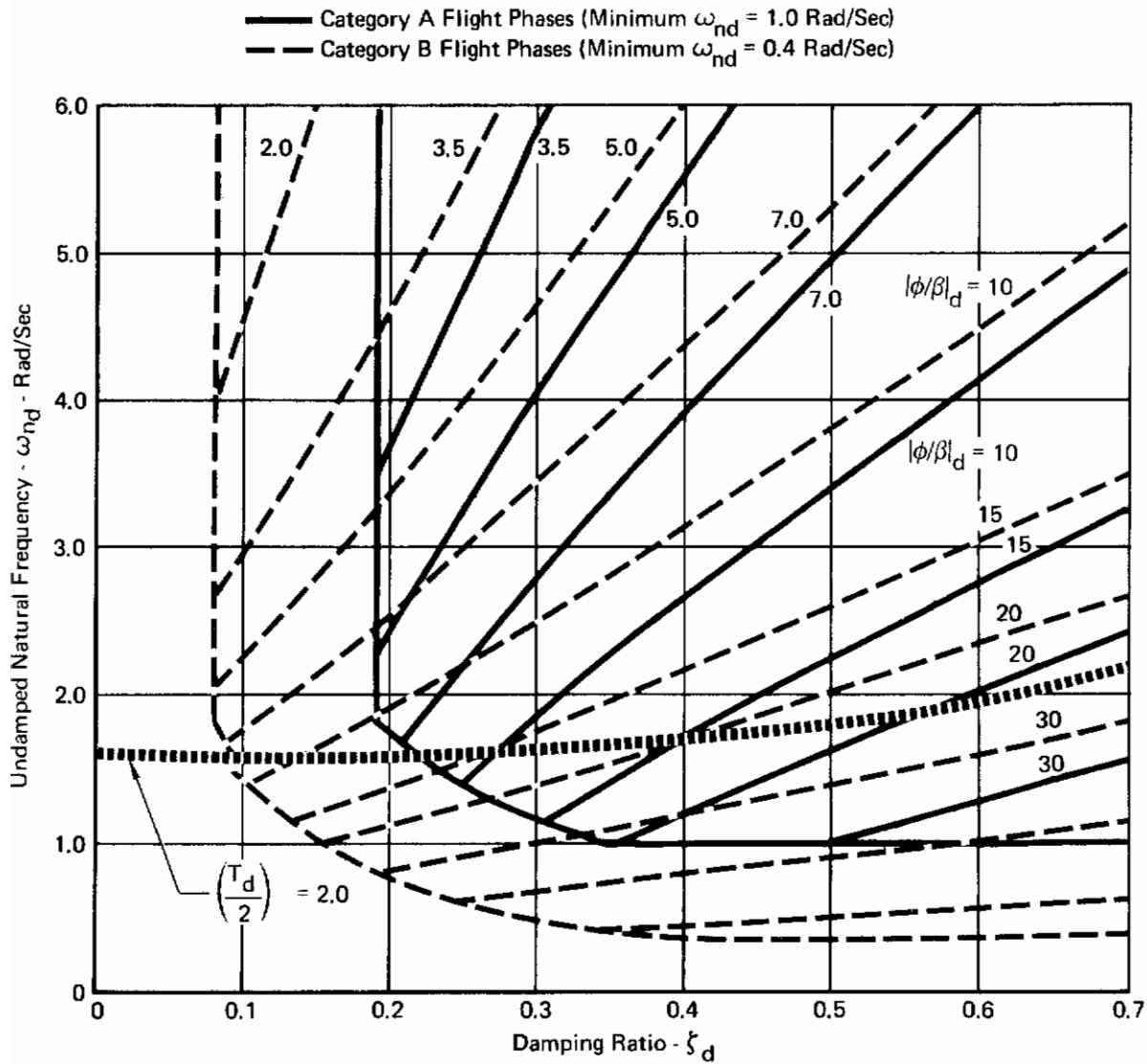

FIGURE 6
DUTCH ROLL FREQUENCY AND DAMPING REQUIREMENTS
(CLASS IV, CATEGORY A AND B, LEVEL 1)

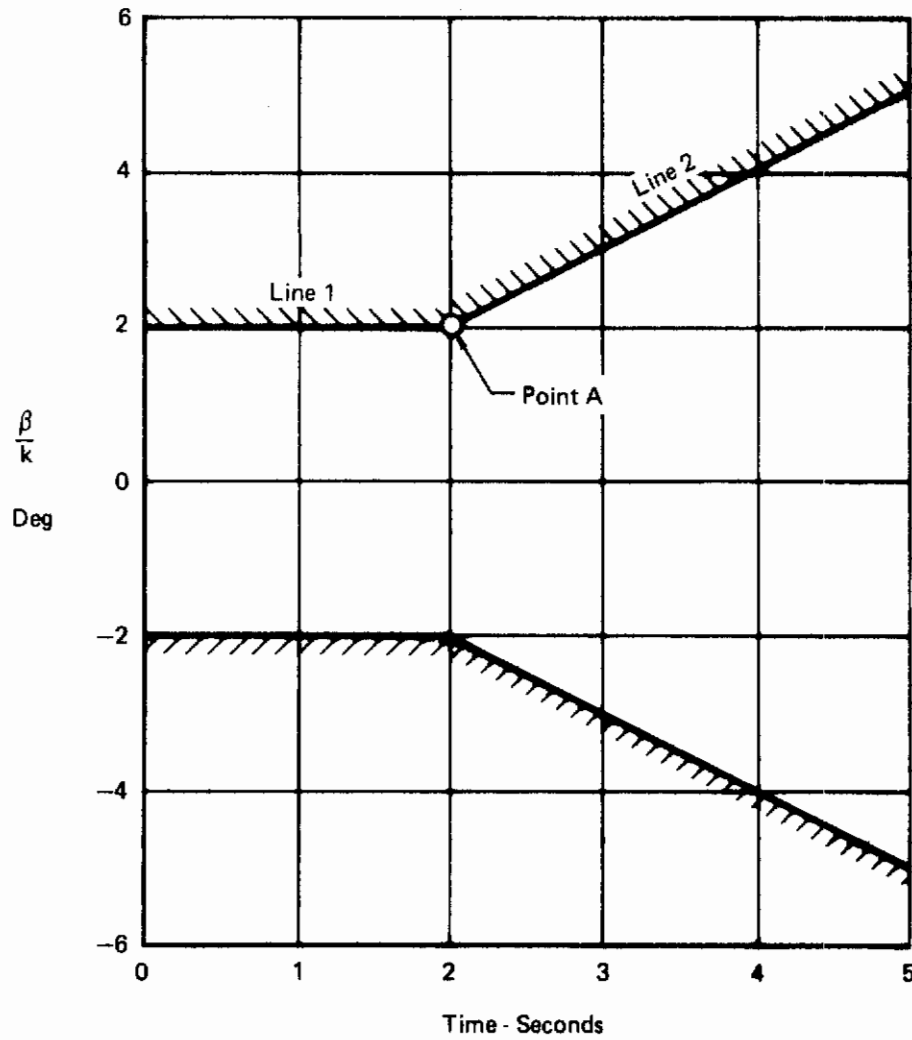

FIGURE 7
SIDESLIP TIME HISTORY ENVELOPE FOR LATERAL STICK FORCE INPUT

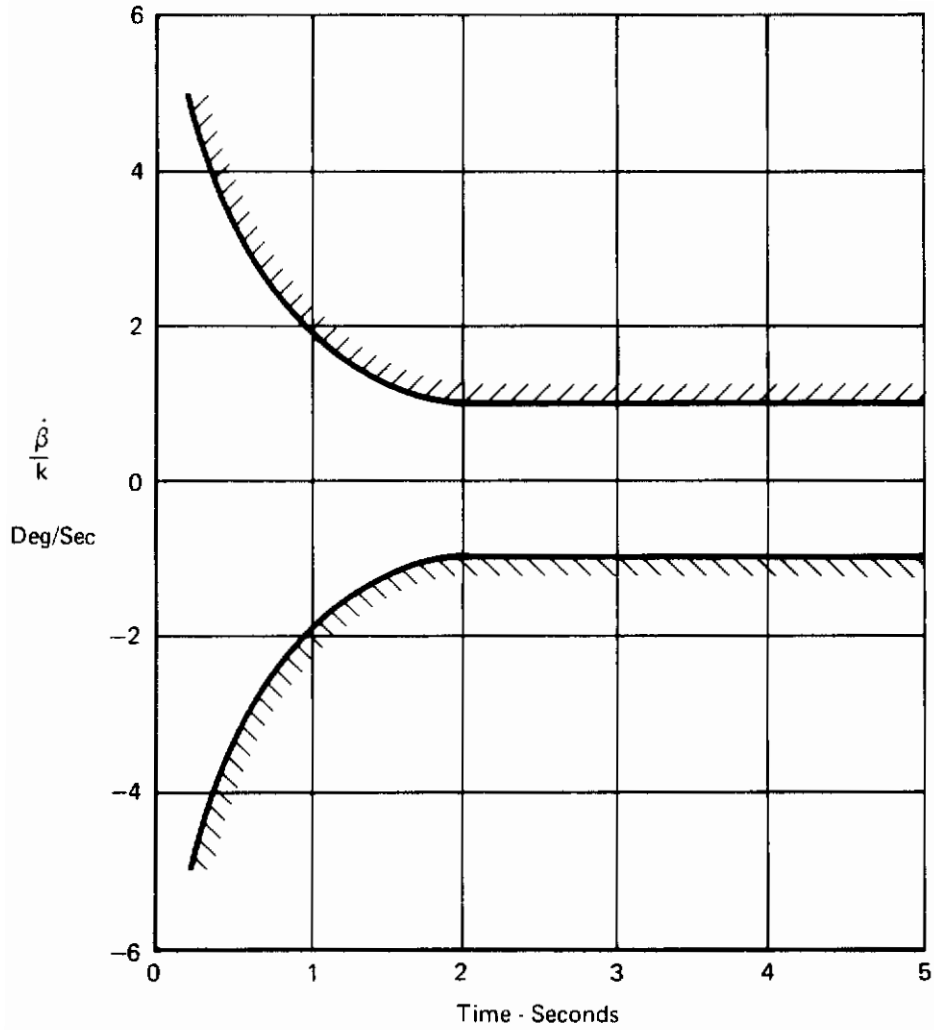

FIGURE 8
SIDESLIP RATE OF CHANGE TIME HISTORY ENVELOPE
FOR LATERAL STICK FORCE INPUT

Contrails

made by MCAIR pilots that lateral acceleration is a principal motion cue parameter at high speeds, resulted in the formulation of the D* concept. The D* expression is a functional combination into one mathematical equation of aircraft sideslip, which is considered the principal low speed handling quality parameter, and lateral acceleration, which is a more important consideration during high speed flight. D* is defined as,

$$D^* = \Delta n_{y_p} + K_3 \beta$$

Where K_3 is a crossover gain constant which is related to dynamic pressure as shown in Table III. In contrast to the C* concept where the equivalent gain constant is a function of velocity, the D* equation employs a crossover dynamic pressure to establish when low and high speed flying qualities are rated equally.

(1) Crossover Gain Constant

The crossover gain constant for the C* equation is also a dimensionalizing constant relating steady state pitch rate to normal acceleration in the following way,

$$(n_z)_{ss}/(q_{ss}) = (K_2)V$$

where the units for K_2 are as given in Table I. In a similar way, the steady state lateral acceleration and sideslip angle are related by the expression,

$$(n_y)_{ss}/(\beta_{ss}) = (K_3)q$$

where the definition and units of K_3 are as given in Table III. The crossover gain for C* is explicitly constant whereas K_3 is constant because the parameter C_y is reasonably invariant throughout the F4 flight envelope. Preliminary investigations indicate that this parameter is relatively constant for a number of fighter aircraft currently in use.

(2) Crossover Dynamic Pressure

Of the references included in the literature survey and reviewed during the program, very little flight test information was found to be directly applicable toward assessment of a crossover dynamic pressure value. Consequently, it was necessary to estimate a representative value based on pilot experience with the F4 aircraft, and available information in Reference 3. The final value chosen during the analysis was based on the following considerations:

- (a) The F4 primary flight control system mechanization includes an Aileron Rudder Interconnect (ARI) which is activated at 230 knots Indicated Airspeed (@ Sea Level, Dynamic Pressure

TABLE III
DEFINITION AND UNITS FOR D* EQUATION

● Definition

$$D^* = \Delta n_{yp} + K_3 \beta$$

Δn_{yp} = Incremental Lateral Load Factor at Pilot Station

β = Sideslip Angle

K_3 = $C_3 q_{co}$ Sideslip Gain Constant

C_3 = Dimensional Constant

q_{co} = Crossover Dynamic Pressure

● Units

D*	Δn_{yp}	β	C ₃	
			Value	Units
g's	g's	rad	-9.91×10^{-3}	$\left(\frac{g's \cdot ft^2}{lb} \right)$
		deg	-1.73×10^{-4}	$\left(\frac{g's \cdot ft^2}{lb \cdot deg} \right)$
ft/sec ²	ft/sec ²	rad	-3.19×10^{-1}	$\left(\frac{g's \cdot ft^2}{lb \cdot sec^2} \right)$
		deg	-5.57×10^{-3}	$\left(\frac{ft^3 \cdot rad}{lb \cdot sec \cdot deg} \right)$

● Assumption

$$q_{co} = 350 \text{ lb/ft}^2$$

Contrails

= 180 pounds per square foot) to compensate for the adverse yawing effect inherent during the landing flight conditions. Since the ARI is principally used during take-off and landing (Phase C), it is felt that the value of dynamic pressure at Phase C initiation should be considered a lower bound for the crossover dynamic pressure used in Phase A and B.

- (b) From F4 aircraft flight test data obtained during rolling pull-out maneuvers, it can be shown that the maximum sideslip angle decreases from high adverse values at low speeds, to low adverse values at high speeds, with the transition point occurring in a dynamic pressure range of about 600 to 700 pounds per square foot.

These values are indicative of the upper bound values for the crossover dynamic pressure.

A median value of 350 pounds per square foot was selected as the crossover dynamic pressure for use in the SFCS program in part because it is compatible with the above limits. This choice is also based on data as presented in Reference 2 and 5 for the F-84 and F-86 aircraft. In both cases, data for the maximum lateral load factor during fish tail and rolling pull-out maneuvers show that the pilots generated constant (maximum) sideslip values at low speeds and constant (maximum) lateral acceleration at high speeds with transition occurring in about the same dynamic pressure range.

- (3) D* Criterion Candidate

Having assessed the physical importance of sideslip and lateral acceleration as described in the above sections, an effort was made to combine these parameters into one criterion. It was reasoned that the lateral acceleration and sideslip angle contributions should be equal at crossover dynamic pressure flight conditions in order for the criterion to represent high and low speed flight. If the two are equal then the candidate sideslip criteria discussed in Section V.2.b can be considered to represent one-half of the acceptability level for both. The D* equation can be expressed, in modified form, as,

$$\frac{D_1^*}{k} = \frac{\beta}{k} + \frac{\Delta n_{Yp}/K_3}{k}$$

and the sideslip boundaries can be doubled to form the new criterion as shown in Figure 9.

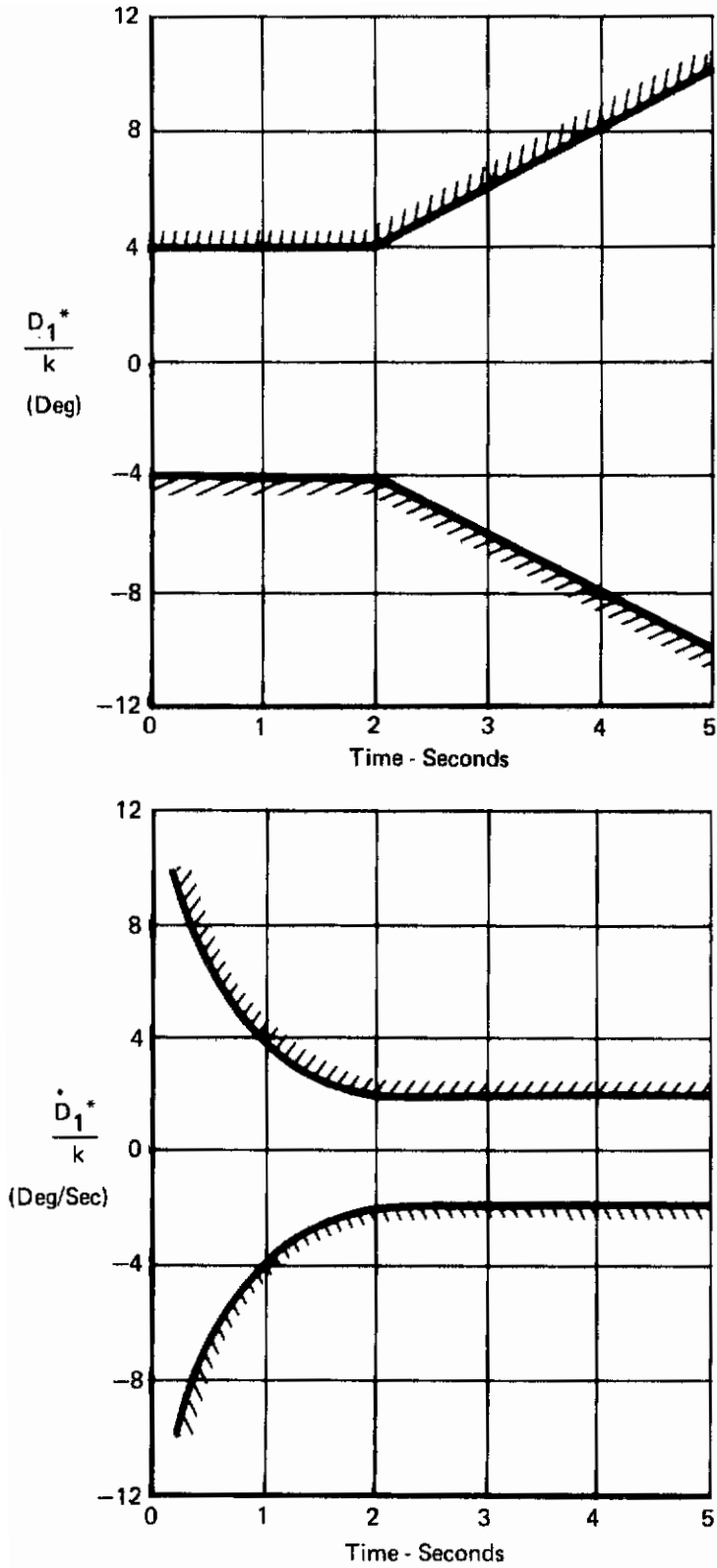

FIGURE 9

DIRECTIONAL TIME HISTORY CRITERION
FOR LATERAL STICK FORCE INPUT

c. Directional Response to Rudder Command Input

Analysis of the yaw axis response characteristics for rudder pedal inputs was limited due to the unavailability of sufficient information in Reference 3 for establishing criterion boundaries as was possible for the lateral control input criterion. Consequently, no criteria boundary could be formulated and directional response investigations for criteria development were relegated to the simulation phase in which several configurations were tested. From preliminary discussions with flight test personnel, it was concluded that during yaw axis control and flight maneuvers, pilots have differences of opinion in terms of rudder pedal usage. Some feel that all yawing maneuvers are generally conducted with "feet on the floor", and they do not need a very responsive yaw axis. Others indicate some usage of rudder pedals, for mission modes where control of velocity vector is important and small angle positioning of aircraft heading is critical. In general, it was felt that a minimum transient response level was required to insure that adequate maneuvering capability was provided for use by those pilots who desired it.

3. LATERAL

Pilot comments indicate that roll axis handling qualities are principally influenced by roll power, roll sensitivity, and roll transient dynamics. The Reference 3 users guide associates a number of requirements with the roll transient dynamics in an effort to maintain adequate speed of response with minimum coupling of Dutch Roll oscillations into the roll axis. It was the intent of the roll axis analysis effort to combine current specifications dealing with:

- o Maximum Roll Rate Time Constant
- o Peak Roll Rate Oscillations
- o Ratio Of Oscillatory Component To Average Roll Rate Component

into a time history envelope of acceptability which reflects in composite form the desired dynamic properties for a fly-by-wire type aircraft.

Roll Rate Criterion Candidate - The normalized lateral-directional equations of motion shown in Appendix II were mechanized on an analog computer and the time history response traces for step aileron command inputs were recorded. Coupling and modal parameters given in Appendix B were used as a guide in selecting representative values for use during simulation but no attempt was made to duplicate exact values corresponding to stated flight conditions. Selection was also based on following considerations:

a. Modal Parameters

It was assumed that random combinations of acceptable Dutch Roll frequency and damping values as specified in Reference 3 were compatible with arbitrary selection of roll time constant values as shown in Reference 3.

b. Coupling Parameters

These parameters were varied at random with the constraint that the Reference 3 requirements for roll rate oscillation and ratio of Dutch Roll component to average roll component were not exceeded. For all combinations investigated, it appeared that the latter requirement is the more stringent and compliance with it usually satisfies the peak roll rate requirement too.

The data shown in Table IV give specific values for the coupling and modal parameters used in the normalized equations (B20 and B21, Appendix II) to generate the time history data shown in Figure 10. The roll rate criterion was formulated by drawing a periphery envelope around the outside edges of the response traces as is indicated in the figure. The resultant plot constitutes the roll rate criterion candidate to be used during the SFCS program for control law development and equipment design.

4. WEAPON DELIVERY

Air-to-air and air-to-ground combat modes are the most severe flight phases in a tactical environment since they require rapid maneuvering, precision tracking, and precise flight path control. In order to investigate the performance characteristics encountered and to attain a better understanding of the transient dynamics involved, a closed loop analysis of the overall tracking loop was performed.

The elevation and traverse errors between the attacking aircraft's gunline and its line of sight to the target were developed and are shown in Appendix II. These equations are derived in terms of the attacking aircraft's velocity, angle of attack, sideslip and body rate, the tracking range and the target's velocity components defined in earth coordinates. Also shown in Appendix II is the formulation of linearized block diagrams of the elevation and lateral fire control modes for tracking both aerial and stationary ground targets.

After formulation of tracking loop equations an analysis was performed to identify which parameters significantly affect tracking stability and weapon delivery precision. Root locus techniques were used to stabilize the tracking loop for pilot model gain and gun angle variations, and time responses obtained using a digital program (Reference 7) for two flight conditions.

**TABLE IV
COUPLING AND MODAL PARAMETERS**

Configuration Number	T_0	ζ_0	ω_0	X_1	X_1X_2
1	0.1	0.19	1.84	0.15	0.30
2	0.1	0.58	4.00	0.15	0.30
3	0.1	0.19	3.50	0.15	0.30
4	0.1	0.19	1.84	0.10	0.20
5	0.1	0.60	2.00	0.15	-0.30
6	0.1	0.44	3.00	0.15	-0.30
7	0.1	0.58	4.00	0.15	-0.30
8	0.1	0.19	3.50	0.10	-0.20
9	0.1	0.26	5.00	-0.15	+0.30
10	0.1	0.19	5.00	-0.10	+0.20
11	0.1	0.58	4.00	-0.15	+0.30
12	0.1	0.31	6.00	-0.10	-0.20
13	0.1	0.60	2.00	-0.10	-0.20
14	0.1	0.60	2.00	-0.15	0.30
15	1.0	0.19	1.84	-0.15	0.30
16	1.0	0.60	2.0	-0.15	0.30
17	1.0	0.44	3.00	-0.15	0.30
18	1.0	0.58	4.00	-0.15	0.30
19	1.0	0.19	3.50	-0.15	0.30
20	1.0	0.31	6.00	-0.15	0.30
21	1.0	0.60	2.00	0.15	0.30
22	1.0	0.44	3.00	0.15	0.30
23	1.0	0.19	3.50	0.15	0.30
24	1.0	0.19	1.84	0.15	-0.30
25	1.0	0.44	3.00	-0.15	-0.30
26	1.0	0.58	4.00	0.15	-0.30
27	1.0	0.26	5.00	-0.15	-0.30
28	1.0	0.19	3.50	0.15	-0.30
29	1.0	0.19	3.50	0.15	-0.30
30	1.0	0.31	6.00	0.15	-0.30

Note: $X_1X_3 = 0$ for all configurations.

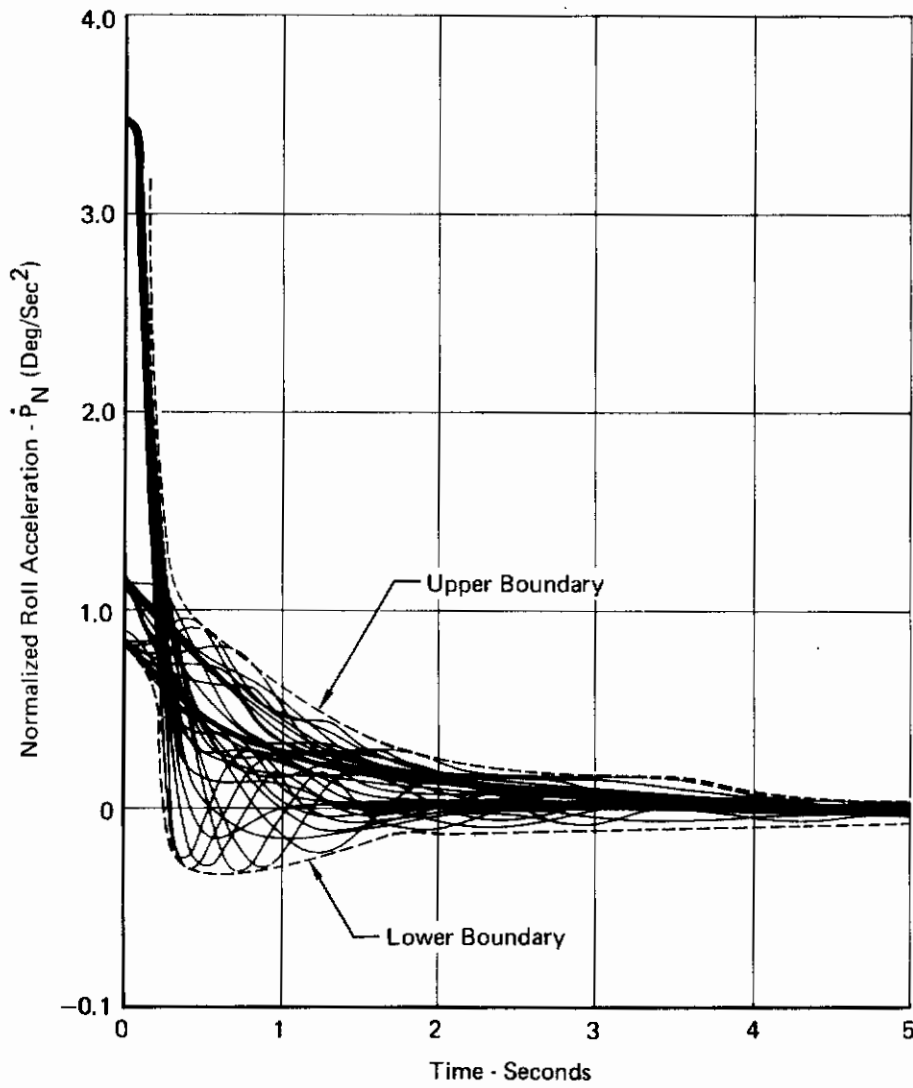
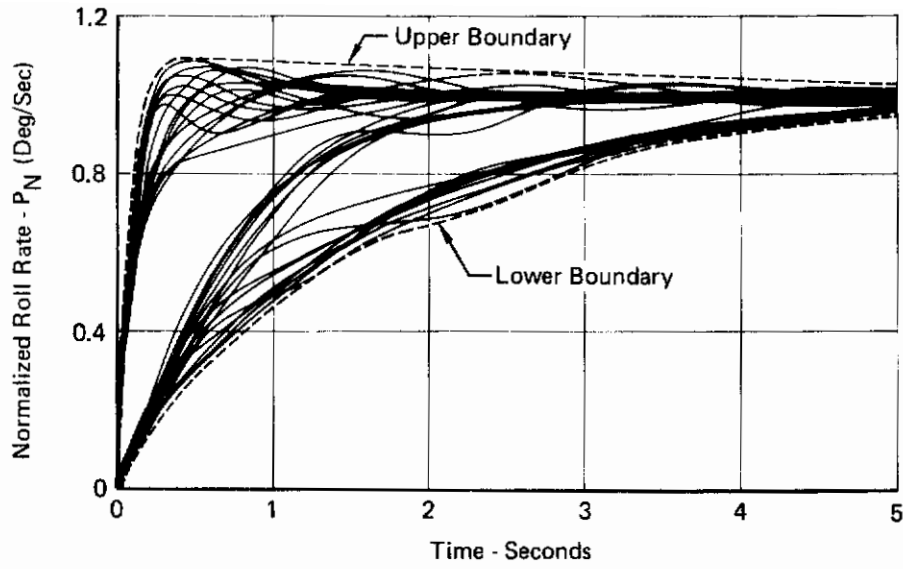

FIGURE 10

ROLL AXIS TIME HISTORY RESPONSES FOR LATERAL STICK FORCE INPUT

a. Flight Path Program

The digital program described in Reference 7 includes a six-degree-of-freedom airframe with flight path geometry and pilot math model. It is programmed to aim the attacking aircraft guns at a target, stationary or moving, starting from some initial offset position, to a final position satisfying the fire control mode requirements and approaching zero error in elevation and traverse channels. The pilot model representation used in the study was a pure gain which was varied with flight condition. This representation was selected instead of a more refined model with frequency and phase sensitivity, because it was previously established that equivalent accuracy in closed loop tracking stability was obtained with the simpler representation.

b. Digital Computer Results

Time history traces were obtained for two flight conditions and two gun angle positions, γ_e . The effect of longitudinal feedback variations on weapon delivery precision was investigated by obtaining time history responses for the elevation angular error for different longitudinal configurations. Figure 11 shows the time history response for the elevation angular tracking error for several of the configurations.

The time responses were obtained for the target aircraft flying straight and level at the velocity equal to the pursuer's velocity with the attacking aircraft initially 100 feet below and 2000 feet behind the target. The range rate was zero for all the traces obtained.

From Figure 11 it can be seen that the elevation angular error is a direct function of the configuration characteristics and that it varies proportionally with the gun angle. The tracking performance is measured by how fast the tracking error approaches 10 mils or less and the length of time it stays below that value. For the configurations with higher order oscillations in longitudinal response, the angular error is very oscillatory, which would indicate that the pilot would have a harder time in keeping the error below 10 mils.

From the studies and time history traces, the following conclusions can be stated for weapon delivery accuracy:

- o Aircraft short period pitch and Dutch roll damping have significant effects on the tracking accuracy.
- o Increased damping improves tracking markedly.
- o Dutch Roll damping has a more pronounced effect on tracking than the short period pitch damping.

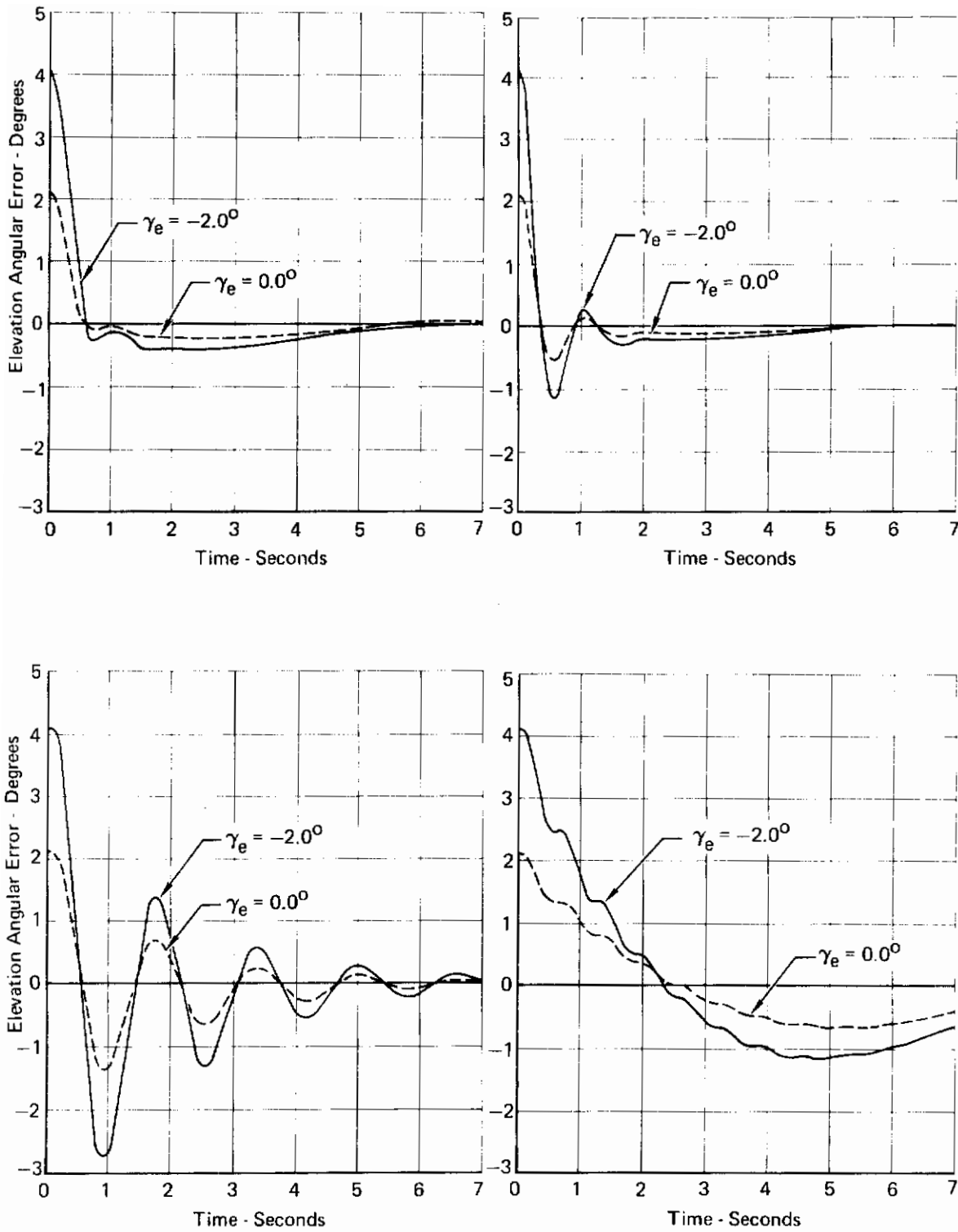

FIGURE 11

TIME HISTORY RESPONSES FOR ELEVATION ANGULAR TRACKING ERROR

Conclusions

- o Lateral tracking stability is improved when the gun angle is elevated above the instantaneous aircraft roll axis.
- o The optimum gun elevation angle is from 0 to 2 degrees above the waterline axis.

The effects of parameters such as stick dead zone, backlash, pre-load, and coulomb friction were not analytically studied, but the simulator pilots indicated that the best control harmony, considered necessary for precise tracking with minimum effort, is obtained with these parameters held as low as possible.

SECTION VI

SIMULATION

To investigate the pilot's performance using a man-in-the-loop simulation, a comprehensive test plan was formulated using the analysis and study results obtained above as a guide. From the beginning, it was realized that a very complete hybrid mechanization was necessary to achieve high visual fidelity and maximum crew station realism with the fixed base simulator equipment. To satisfy this requirement, a major portion of the software and flight control system data was programmed on a digital computer which interfaced through an analog computer to the crew station hardware. Each pilot was required to fly a baseline mission with various configurations and then provide a COOPER-HARPER rating for each of five scored mission phases. Non-scored intermediate phases such as climbs and dives were included as transition modes to aid in blending the scored phases into one unified mission which took approximately ten (10) minutes to complete. These transition modes also provided additional opportunity to the pilot for open loop evaluations using rudder kicks and stick raps. Pilot comments on specific tests configurations which were investigated and a large amount of associated scoring data constituted the essential means of establishing the performance level achieved by the pilots in each category of runs.

1. CREW STATION CONFIGURATION AND HARDWARE

A fixed base crew station was used in the SFCS flight simulator which was equipped with both center stick and side stick controllers and instrumentation for three-axis aircraft maneuvering throughout the flight envelope.

a. Primary Flight Instruments

Included in the SFCS flight simulator were the necessary instruments for control of aircraft altitude, angular rate, and velocity during flight. The solution of the equations-of-motion and coordinate transformations generated signals to drive the following instruments:

- o ATTITUDE/DIRECTION INDICATOR (ADI)
- o AIRSPEED/MACH METER
- o ANGLE-OF-ATTACK INDICATOR
- o BAROMETRIC ALTIMETER
- o RATE-OF-CLIMB INDICATOR
- o NORMAL LOAD FACTOR
- o ENGINE TACHOMETERS

Contrails

The following warning lights were provided to the pilots:

- o FUEL LEVEL LOW - Fuel has been consumed so that weight is less than 33,000 lbs.
- o ALTITUDE WARNING - Indicates that the altitude is less than 3000 feet.
- o DUCT OVERHEAT - The high speed operational flight envelope of the aircraft has been exceeded when this light is illuminated.
- o MASTER CAUTION - This light is activated whenever one of the three lights above are active.
- o SPEED BRAKE - Indicates that the speed brake has been extended.
- o SCORING LIGHT - Flashing light indicates that the entry conditions have been satisfied for that particular mode. Depression of the score activation button on the center stick or side stick initiates the scoring mode, and illuminates the light in a steady (non-flashing) manner. During transition modes the light is extinguished.

b. Flight Controls

The flight controls installed in the cockpit include the following:

- o RUDDER PEDALS - Rudder pedal displacements caused by the pilot are sensed and transmitted to the hybrid computer in equivalent electrical form. A rudder feel system in the form of a mechanical spring operates in parallel with the rudder pedal linkage to provide a reaction force feel and to recenter the rudder pedals in the simulator.
- o THROTTLE QUADRANT - A conventional throttle quadrant mounted in the left hand console of the crew station cockpit incorporates mechanical stops for the IDLE, MILITARY and AFTERBURNER power settings and provides throttle angles from 20 to 120 degrees. The electrical signal from the throttle quadrant serves as an input to the programmed equations-of-motion and represents a command signal to a simulated twin engine, symmetrical thrust, power plant.
- o SPEED BRAKE - A switch located on the inboard throttle extends and retracts the speed brake in the simulated aircraft and initiates computation of aerodynamic drag for retardation of aircraft motion during flight.
- o CENTER STICK CONTROLLER - Lateral stick displacement by the pilot generates equivalent spoiler and aileron motions. A mechanical feel system, similar to that used for rudder pedals, provides the lateral stick feel sensed by the pilot. A specifically designed force feel/hydraulic actuation system is used to generate a centering force in the longitudinal axis. Signals proportional to out-

Contrails

put displacement from this system result in stabilator deflections. The stick grip has an operational trim switch used to manually trim the stick longitudinally. The trigger button, bomb release button, and score activation button are located on the center stick grip. The trigger button is used to manually terminate the ground attack scoring, while the bomb button is used to terminate weapon delivery mode. When the scoring light is flashing, the pilot depresses the scoring button to initialize the scoring mode.

- o SIDE STICK CONTROLLER - A side stick controller is installed in the crew station. Lateral displacements produce spoiler and aileron motions while the longitudinal displacements result in stabilator deflections.

A feel system in the form of a mechanical spring is installed to provide lateral and longitudinal feel to the pilots. The pitch vernier thumbwheel (spring loaded) which generates input command to the pitch axis control system is located on the side stick. A trigger button, bomb button and score button are located on the side stick grip. They perform the same function as those located on the center stick which were described above.

- o SFCS TRIM PANEL - A trim panel, mounted in the left console, contains three electrical trim pots (non-spring loaded) for pitch, roll and yaw channels and one yaw vernier thumbwheel (spring loaded) which generates input commands to the yaw axis.

c. G Seat Cushion

A pneumatic seat cushion device is incorporated in the cockpit and its inflation is regulated in proportion to the normal acceleration at the pilot seat generated through the airframe. During its operation the pilot is pressed against a restraining seat belt harness by the air cushion device and is subjected to the varying force levels during the flight. A similar device is used for generating left-and-right motion cues. Forces proportional to the lateral acceleration at the pilot station as generated during flight regulate the pressure in the twin cushion device for lateral motion.

d. Longitudinal Feel System for Center Stick

An artificial feel system is installed in the flight simulator to provide realistic stick forces to the pilot. The system consists of the following components: (1) a transducer which senses mechanical force inputs, (2) analog equipment used to compute the force output of the longitudinal feel system, and (3) an auxiliary hydraulic cylinder attached to the longitudinal control column of the flight simulator.

Signals proportional to the transducer output and the desired stick force are amplified and applied to the control valve of the auxiliary hydraulic cylinder. The auxiliary cylinder acts as a spring with

fixed spring constant and movement of the cylinder results in a force which the pilot feels at the grip.

e. Visual Display System

The display equipment used in the simulation includes a large scale terrain map (10 ft. by 40 ft.) shown in Figure 12 with a camera system which transmits the visual target over the complete field of view to the crew station. The map scale is 1000/1 which gives equivalent translations of 10,000 feet by 40,000 feet and an equivalent elevation range of 95 feet to 9600 feet. For the air-to-ground modes of operation the target consists of a "bulls-eye" located on the model landing strip. An image of this target is displayed on a wall screen inside the crew station room using a television projector. During the dive bombing mode of operation, a 81 mil depressed pipper collimated at infinity is also projected on the wall screen for target tracking. In the strafing mode and air-to-air combat mode, the pipper is automatically moved back to a waterline reference point corresponding to gunline harmonization.

The equipment employed in the target aircraft image generation is housed in two locations in the simulation area. The model tunnel area consists of a 3-axis gimballed aircraft model and a fixed television camera. The equipment located in the crew station room consists of a gimballed target projector for presentation of the maneuvering target aircraft.

f. Crew Station Hardware Usage

Written instructions to pilots as summarized in Appendix VI indicates their participation to be grouped into two phases consisting of an evaluation phase and a documentation phase. During the evaluation phase, the hybrid simulation setup including the g seat, trim panel and side stick controller was evaluated by MCAIR pilots who commented on their use for the documentation phase of the study as well as subsequent SFCS simulation efforts. Accordingly, all three features remained operational in the crew station for the remainder of the study with conditional usage based on the following reasoning:

- o Limited use of the trim panel by participating pilots resulted due to inherently good trim characteristics of the SFCS and emphasis on non-trim handling quality investigations.
- o Extensive use of side stick controller was relegated to later SFCS simulation phases, as reported in Supplement 2, due to unavailability of Supplier's prototype hardware. The side stick controller used in crew station was a converted design aid unit which was functionally representative but not entirely equivalent to the design generated in the time period after completion of this study.

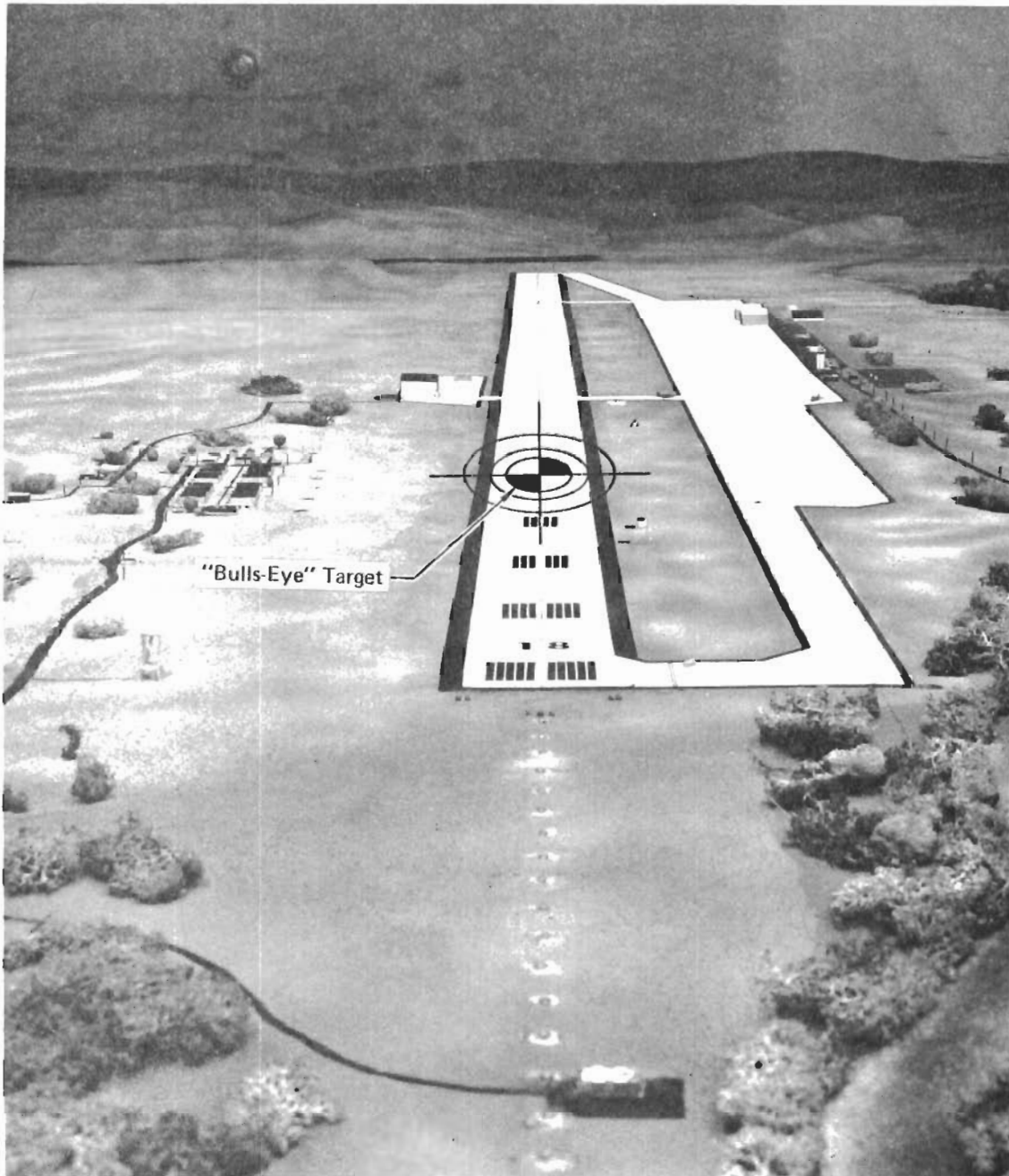

FIGURE 12
VISUAL DISPLAY TERRAIN MAP

- o Use of g seat cushion was available for pilot usage and MCAIR pilot data was taken with g seat cushion operational. Mechanical problems limited its usage during some runs and at times pilots elected not to use it because of the increased fatigue factor involved.

2. COMPUTER SOFTWARE DESCRIPTION

Operation of the hybrid simulator required interfacing the software digital program with the crew station hardware and display equipment using a PACE 131 analog computer and Adage A-D/D-A Converter. Since most of the digital software for real time man-in-the-loop simulation is programmed in FORTRAN IV computer language on a Control Data Corp (CDC) 6600 digital computer, the analog computer's function is principally that of master control for all equipment and buffering of time history recorders. The digital software used in this simulation includes equations representing a six-degree-of-freedom airframe, a three axis flight control system, displays, and scoring computations.

a. Airframe Characteristics

A set of large perturbation, six-degree-of-freedom differential equations of motion is used to describe the nonlinear motion of aircraft during flight. Additional equations are utilized to describe the atmospheric properties, body accelerations and velocity components. The entire set of equations used for airframe simulation are presented in Appendix IV.

The aerodynamic derivatives used in the equations-of-motion are computed in the digital computer every 20 milliseconds. The representation of the aerodynamic derivatives are functions of Mach number, altitude and angle-of-attack.

Tables are developed from basic propulsion data to simulate the thrust developed by two engines. These data are functions of Mach number, altitude and throttle setting. Idle, Military and afterburner power levels are programmed and are available to the pilot for simulated flight maneuvers.

b. Longitudinal Flight Control System

A block diagram of the longitudinal flight control system used in the simulation is shown in Figure 13. As shown in the figure, the force input signal is shaped by a prefilter model before being summed with the feedback signal. The error signal is applied to the simulated stabilator actuator which in turn generates the input to the airframe. The feedback signal, which is the sum of pitch rate and normal acceleration forward of the aircraft c.g., is used to provide invariant aircraft response with changing flight conditions. The desired variations in aircraft flight path time history response are generated by selection of the proper prefilter model.

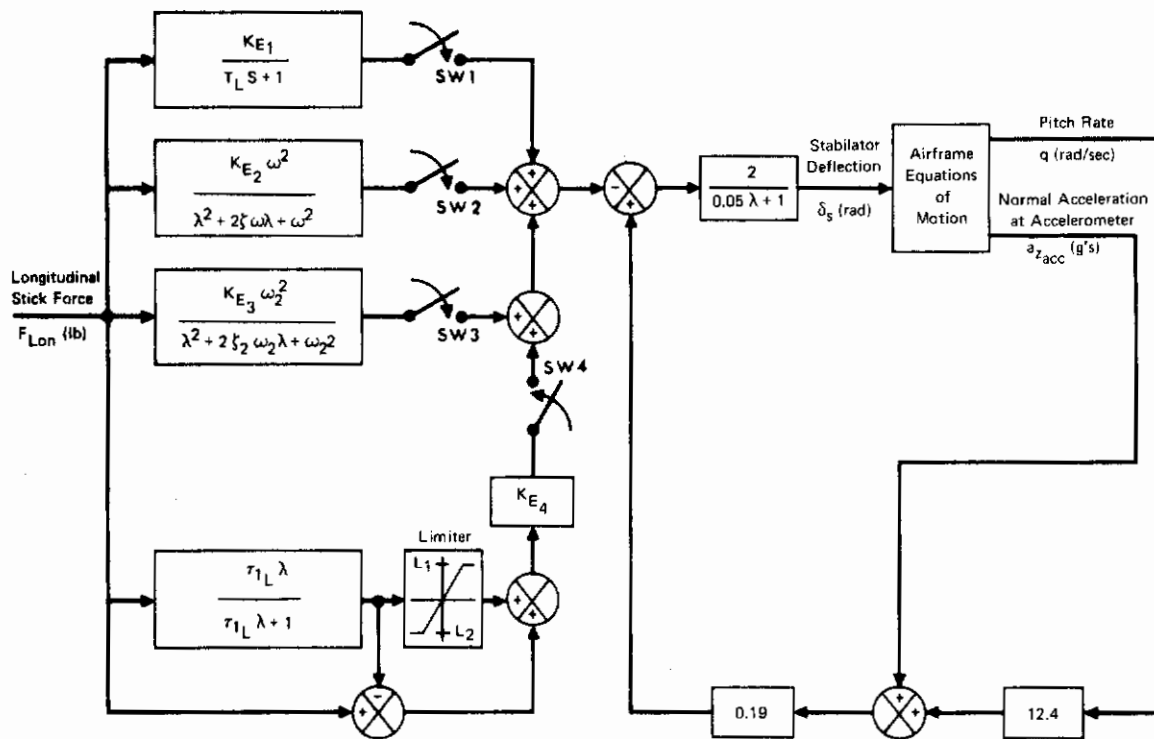

FIGURE 13

LONGITUDINAL FLIGHT CONTROL SYSTEM

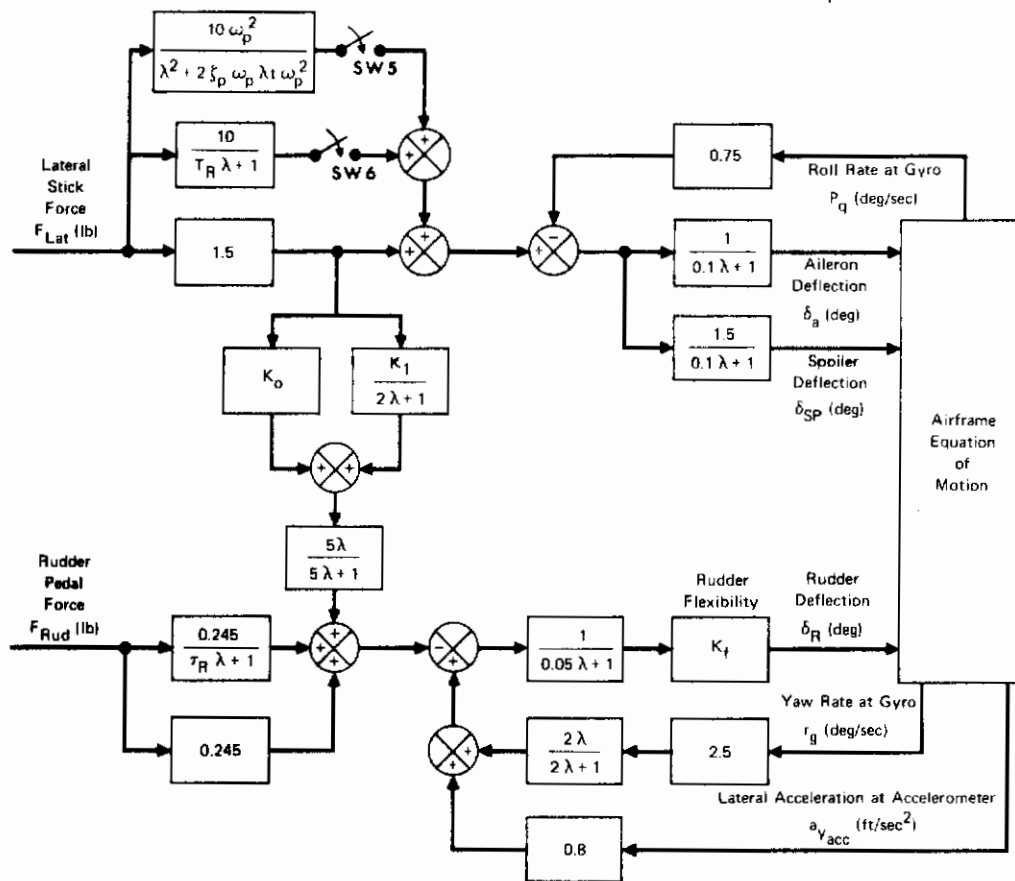

FIGURE 14

LATERAL DIRECTIONAL FLIGHT CONTROL SYSTEM

c. Lateral-Directional Flight Control System

The lateral-directional flight control system shown in Figure 14 uses yaw rate and lateral acceleration feedback to improve the Dutch Roll dynamics and turn coordination. A canceller in the yaw rate feedback loop washes out the yaw rate resulting from a steady state turn. A prefilter is included following the rudder pedal force input to shape the yaw rate response.

Roll rate feedback is used to improve speed of response, roll damping and ϕ/β ratio. A high gain prefilter model is used to mask the basic airframe response. Variations in roll rate response are achieved by varying the prefilter time constant.

A roll to yaw crossfeed is used in order to reduce the sideslip resulting from a rolling maneuver. Variations of proverse or adverse sideslip are obtained by varying the crossfeed gains.

d. Display Equations

The equations of motion for the target model, and a coordinate transformation from the simulated earth geometry to the tracking tunnel coordinate system were required for generating the displays used in the crew station. The transformation equations included Euler angles of the target and aircraft, along with relative geometry angles as computed in an earth referenced coordinate system with its center located in the aircraft.

3. SIMULATION MISSION AND TEST CONFIGURATIONS

One of the goals of the SFCS control performance study and simulation was to investigate if control laws should be based upon mission modes or tasks rather than the traditional handling qualities and control techniques. In fulfillment of this requirement, the airframe software with flight control system mechanization as described above was programmed to provide a series of relatively constant aircraft response characteristics in the flight environment of the simulated mission. Groups of configurations were tested with a realistic mission profile to determine how pilot performance in each mode is affected by simulated airframe response characteristics.

Basic aircraft configuration used during simulation testing is described in Appendix IV; specifically aircraft physical data on gross weight, c.g. location, moments of inertia, and wing characteristics. F-4 aircraft aerodynamic data used in the six-degree-of-freedom computer program is given in Reference 11. The data and the values for the flight control system parameters as given below constitute the nominal configuration (Configuration Number 1.01) from which flight control system variations were made as described in the next section. Side stick controller testing during evaluation phase resulted in its use for demonstration purposes and some data taking. Acceptability of SSC feel system dynamics was an area

Contrails

of further investigation in the follow-on simulation effort and it was felt a more complete investigation can be made at that time. Limited testing of side stick controller toward criterion development was scheduled for documentation phase but most testing was to be performed with center stick in which feel system dynamics more familiar to the pilots were used as a reference.

a. Simulation Mission

The simulated mission starts with initial conditions corresponding to level flight at 1000 feet altitude and 0.85 Mach number as indicated in Table V. A manual terrain following system representative of the APQ-99 was mechanized in the pitch axis and a terrain avoidance system with command inputs as shown in Figure 15 was mechanized in the roll axis. This terrain following/avoidance software generated steering signals in the digital computer which were transmitted to the ADI ball in the crew station for deflection of vertical/horizontal indicator needles during LAHS operation. The pilot was instructed to "fly the needles" to minimize the pitch and roll errors and was scored on how well he is able to keep both needles near zero deflection. The scoring interval was automatically terminated after 50 seconds of flight.

In preparation for the weapon delivery (dive bombing) phase, the pilot had to climb to 10,000 feet altitude and turn to a heading of 45 degrees while making throttle adjustments to reach 300 knots calibrated airspeed. At this time a visual display was activated and a 45° dive bombing maneuver towards a ground target was initiated. Elevation error, azimuth error, sideslip angle, and angle of attack were scored during the WD mode. The specified bomb release conditions were 3500 feet altitude at 450 knots calibrated airspeed. The scoring was terminated when the pilot pressed the bomb release button.

Subsequent to pullout and heading changes as shown in the table, a precision cruise phase was initiated in which the pilots maintain constant attitude ($p = q = r = 0$), altitude ($h = 10,000$ ft), airspeed (.85M), and heading ($\psi = 180$ degrees) for 30 seconds. These task parameters were also recorded and scored to determine performance levels achieved with different configurations.

After decreasing altitude, a ground attack (strafing) phase was initiated from 5000 ft. altitude at a heading of 45 degrees East. The pilot task included holding the pipper on the displayed ground target and pressing the trigger when in firing range. The scoring parameters monitored in this phase were the elevation, azimuth, total angular errors, and the sideslip angle.

In the air-to-air (CO) combat phase, a target model was activated as soon as the pilot maneuvered the aircraft to the specified flight environment entry conditions with altitude above 19,800 feet, heading North and Mach number above 1.1. The target model then performed a canned evasive maneuver, shown in Figure 16, which resulted in decreasing airspeed and altitude changes with termination of simulated

TABLE V
SIMULATED MISSION

I.C.	$\psi = -90^{\circ}$ (W) $H = 1000 \pm 100$ ft $M = .85 \pm .05$
Phase 1	LAHS Fly Pitch/Roll Needles - Scored
Phase 2	Climb and turn to: $\psi = +45^{\circ}$ (N045E) $\pm 5^{\circ}$ $H = 10,000 \pm 1000$ ft $V = 300 \pm 25$ KCAL
Phase 3	WD Dive Bombing - Scored $\gamma = -45^{\circ}$ $H = 3500$ Ft $V = 450$ KCAL
Phase 4	Climb and turn to: $\psi = 180^{\circ}$ (S) $\pm 15^{\circ}$ $H = 10,000 \pm 200$ ft $M = .85 \pm .1$
Phase 5	RECON Fly Recon Mode - Scored With $p = q = r = 0$ $\psi = 180^{\circ}$ $H = 10,000$ ft $M = .85$
Phase 6	Dive and turn to: $\psi = +45^{\circ}$ (N045E) $\pm 5^{\circ}$ $H = 5000 \pm 500$ ft
Phase 7	GA Dive and Strafe - Scored
Phase 8	Climb and turn to: $\psi = 0^{\circ}$ (N) $\pm 20^{\circ}$ $H = 21,900 \pm 2100$ ft $M = 1.2 \pm .1$
Phase 9	AIR TO AIR COMBAT - Scored

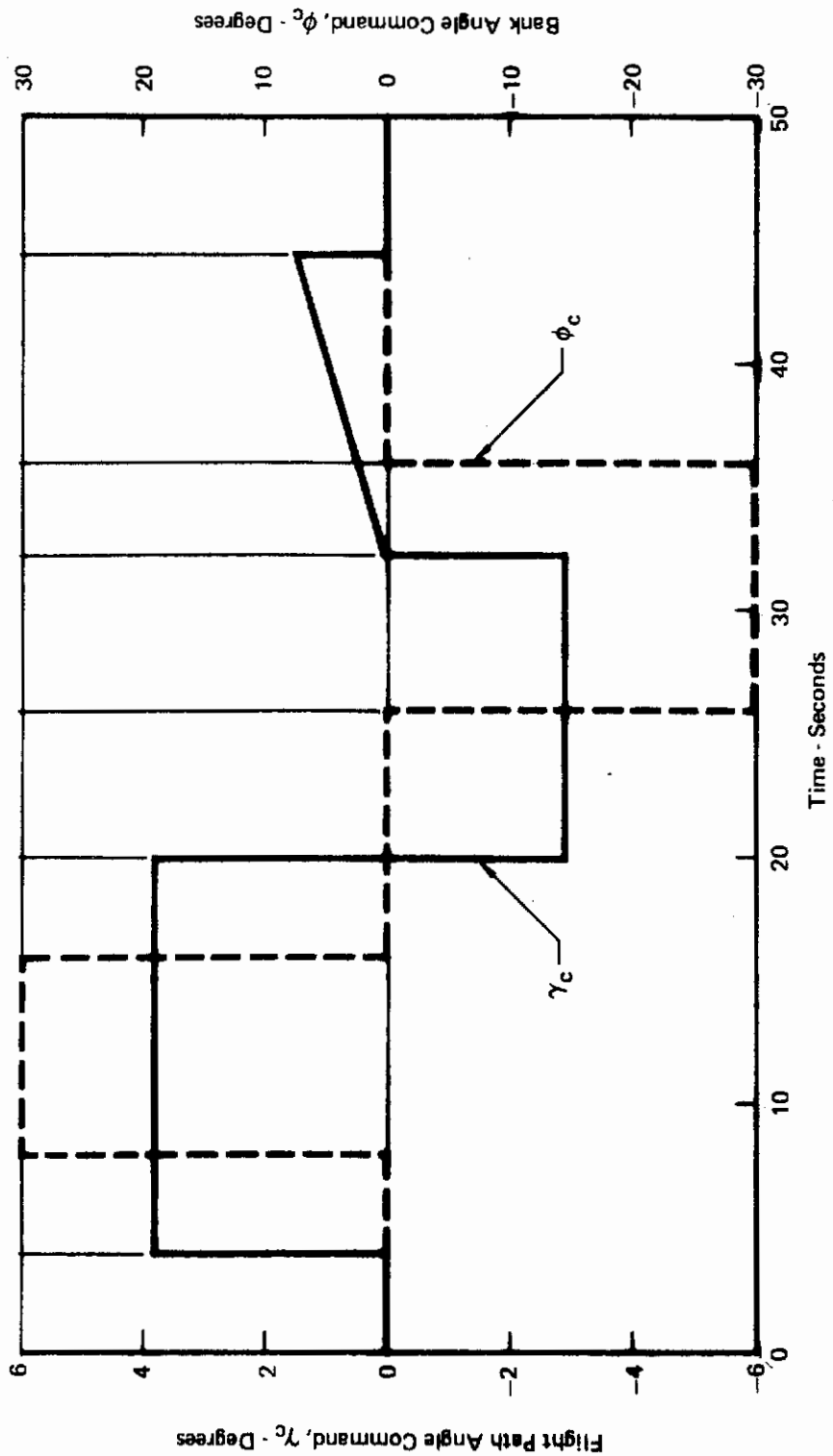

FIGURE 15
TERRAIN FOLLOWING/AVOIDANCE COMMAND SIGNALS

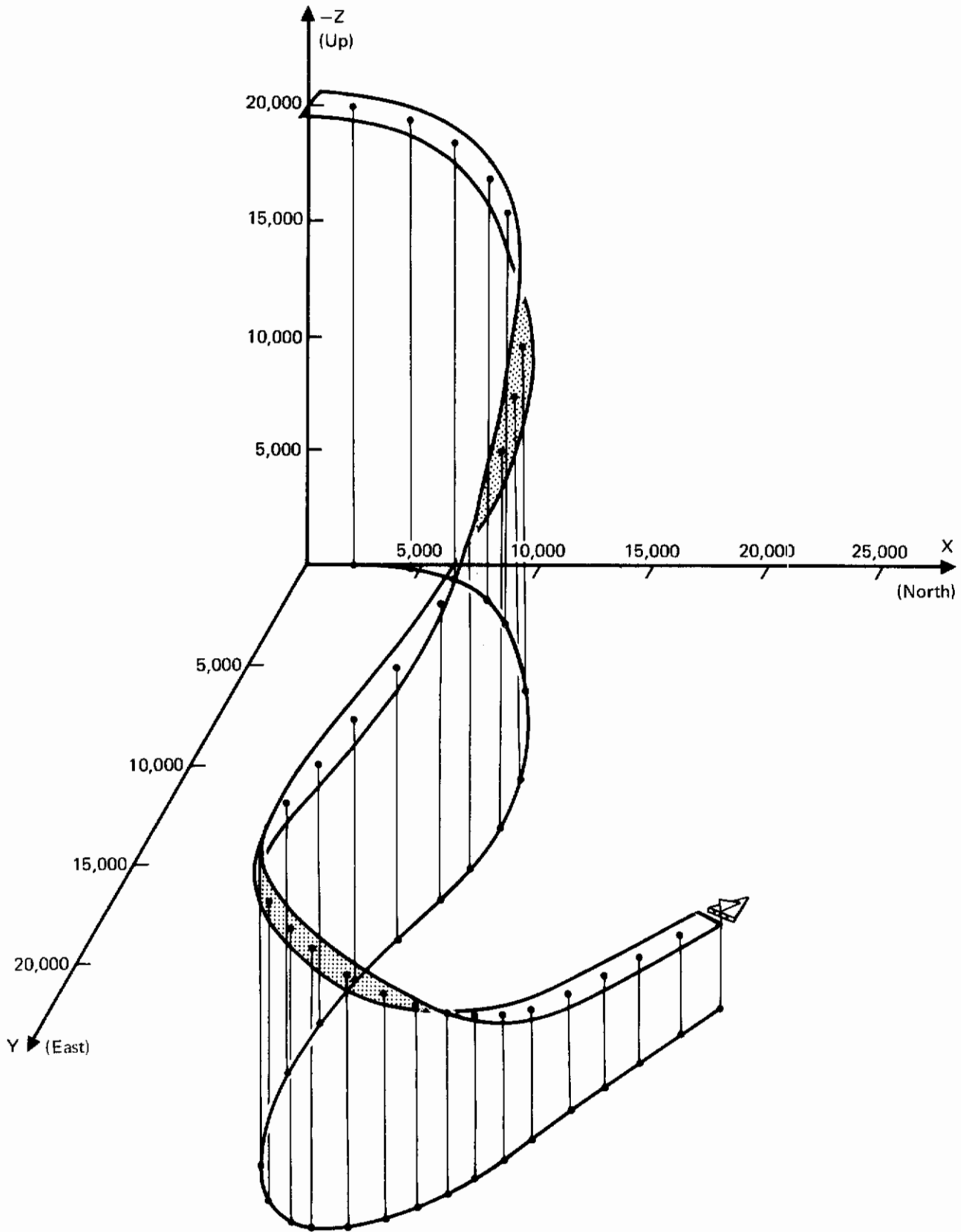

FIGURE 16
SPECIAL TRAJECTORY PLOT OF MANEUVERING TARGET.

Contrails

CO flight phase after 60 seconds of scoring. Performance parameters processed by the digital computer included elevation and azimuth angular errors, total angular error, and range to the target. The mission was terminated automatically at the end of air-to-air combat scoring.

b. Test Configurations

Test configurations were chosen to compliment analysis results and to provide the simulation pilots with performance characteristics which would aid verification of criteria boundaries established during analysis. A total of thirty-three (33) test configurations was investigated, with 15 longitudinal cases and 18 lateral-directional cases. Testing procedure, followed during simulation, included multiple runs per pilot for each configuration.

Referring to Figures 13 and 14 the nominal values for all the parameters are:

$$K_{E_1} = 0., T_L = 0, K_{E_2} = .05, \omega = 5., \zeta = .35, K_{E_3} = 0., \omega_2 = 0.$$

$$\zeta_2 = 0., K_{E_4} = 0., \tau_{1L} = 0., L_1 = L_2 = 0.$$

$$\omega_p = 0., \zeta_p = 0., T_R = .35, K_o = -.1, K_1 = .3, \tau_R = .35$$

K_f = function of Flight Condition with aerodynamic derivatives given in Reference 11.

(1) Longitudinal Configurations

Compatibility of C^* criterion with mission loop closures and application due to time delays, lower C^* boundary, nonlinearities and higher order terms were investigated in the pitch axis. The step response data presented show the time history characteristics as generated with flight control system variations in relation to the C^* and C^* rate of change criteria.

o Time Delay Response Variations (Switch 2 only closed)

Variations due to time delay (ΔT) were determined by holding the output of the digitally generated prefilter signal at zero for the specified (ΔT) length of time. Time histories for two values of delay time are shown in Figure 17.

o Prefilter Time Constant Response Variation (SW 1 only closed)

Effects of lower boundary response variations were generated by varying the prefilter time constant (T_L). Four different values were investigated and the resulting C_N^* and dC_N^*/dt time history responses are shown in Figure 18.

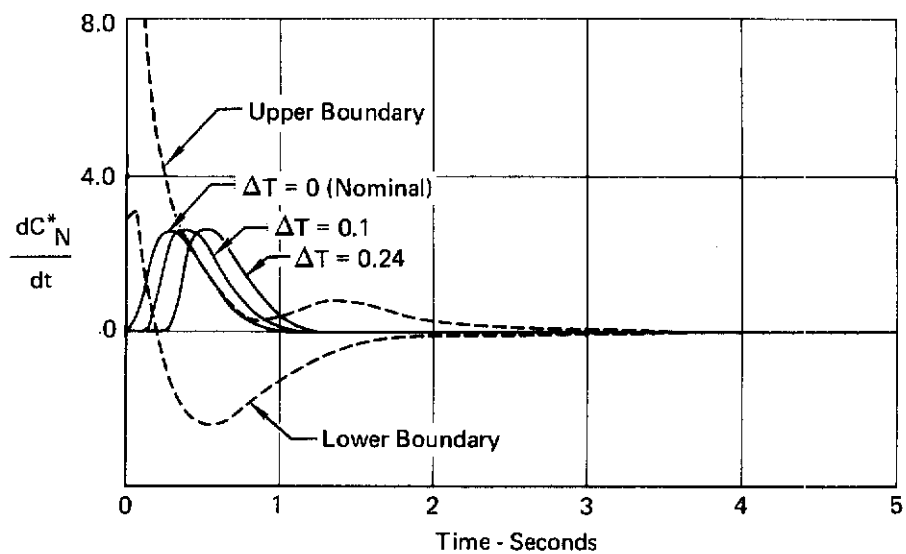
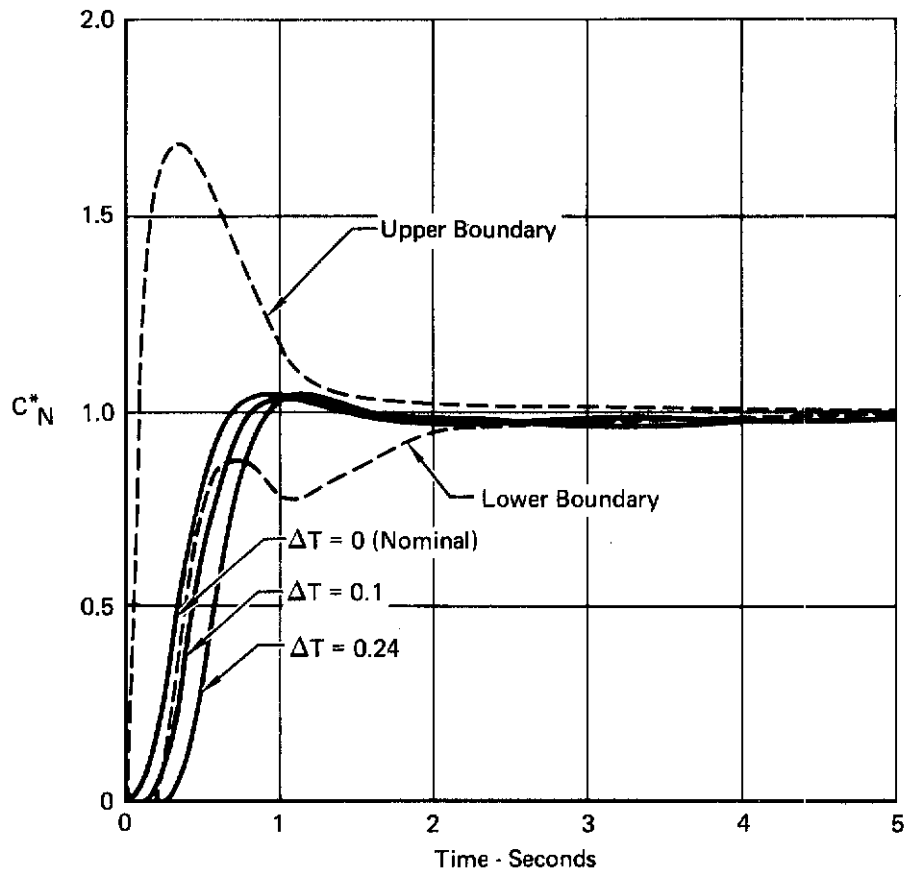

FIGURE 17
LONGITUDINAL TIME HISTORY RESPONSE TRACES
FOR TIME DELAY CONFIGURATIONS

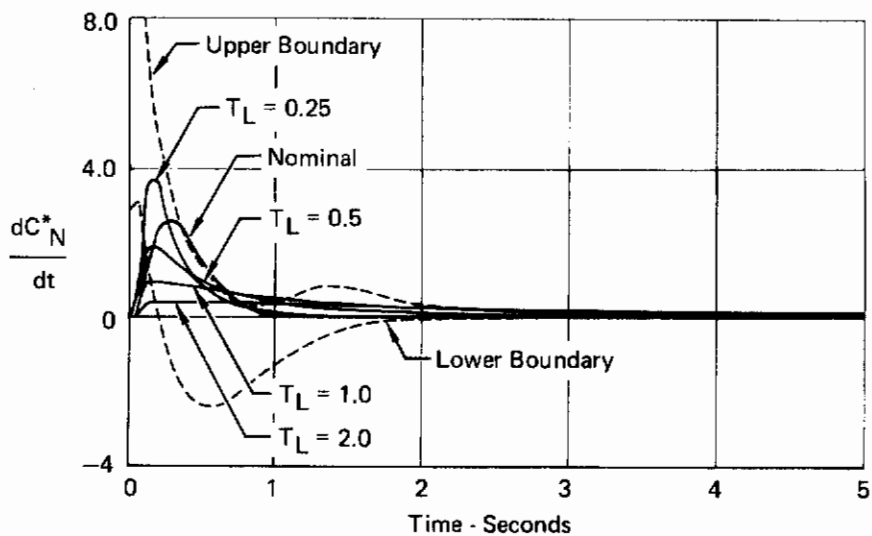
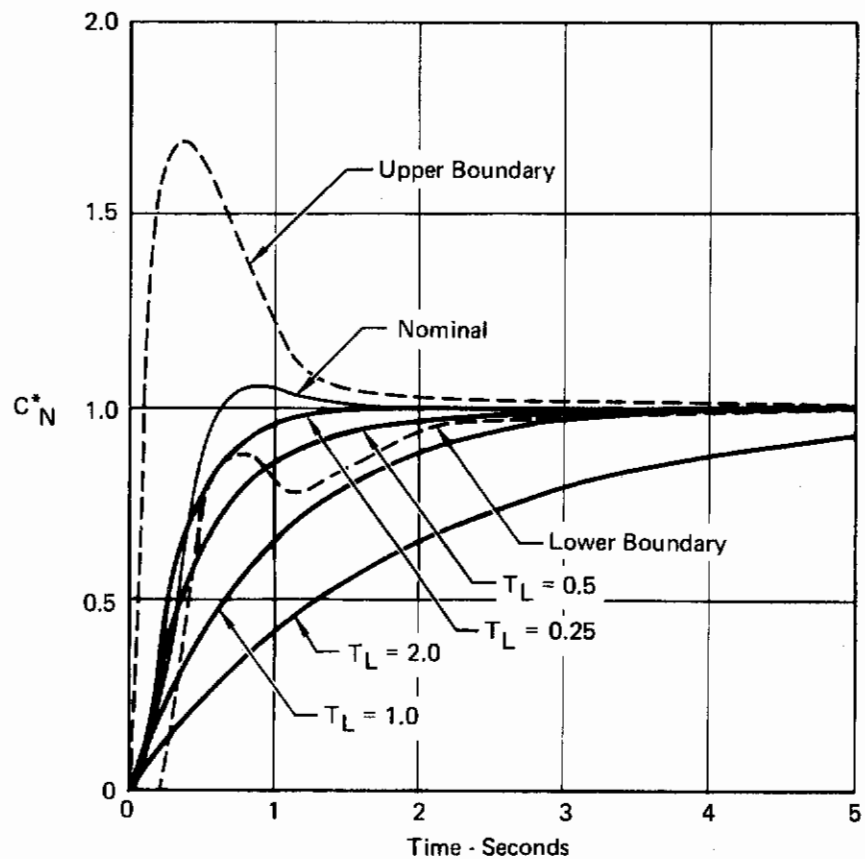

FIGURE 18
LONGITUDINAL TIME HISTORY RESPONSE TRACES
FOR PREFILTER TIME CONSTANT CONFIGURATIONS

Contrails

- o Nonlinear Response Variations (SW 4 only closed)

Nonlinear response variations were obtained with variation of limits (L_1 and L_2) and the high pass time constant (T_{1L}). Corresponding time history responses for step input are shown in Figure 19.

- o Higher Order Response Variations (SW 2 and 3 only closed)

Variations of higher effects on C^* were obtained by variation of prefilter damping (ζ). The normalized time history responses for C_N^* and dC_N^*/dt are shown in Figure 20.

(2) Lateral-Directional Configurations

Lateral-directional handling qualities were investigated with variations in roll prefilter time constant, decoupled responses, and adverse/proverse yaw characteristics.

- o Roll Time Constant Response Variations (SW 6 only closed)

Variations in roll rate response were obtained by varying the prefilter time constant (T_R). Five different values of the time constant were investigated and the corresponding time history responses for aileron step command input are shown in Figure 21 for normalized roll rate (P_N) and normalized roll acceleration (\dot{P}_N).

- o Decoupled Responses (Switch 6 only closed)

Decoupling between the lateral and directional axes was accomplished by modifying the airframe equations of motion and setting the coupling aerodynamic coefficients to zero. Time history traces for aileron step command inputs are shown in Figure 22. Similar traces for rudder step command inputs are shown in Figure 23 for sideslip angle and sideslip rate. The corresponding D_1^* and \dot{D}_1^* responses are shown in Figure 24.

Decoupled aircraft dynamics were investigated to determine if any improvement will result when the lateral-directional aerodynamic coupling is reduced to a minimum. Only a token effort was made in this area as shown in the final results, but the basic concept was to investigate dichotomous operation of the roll and yaw axis.

- o Adverse/Proverse Yaw Response Variations (Switch 5 and 6 closed)

Effects of adverse/proverse yaw variations were investigated by changing the roll to yaw crossfeed gains. Time history traces for aileron command inputs are shown in Figures 25 and 26.

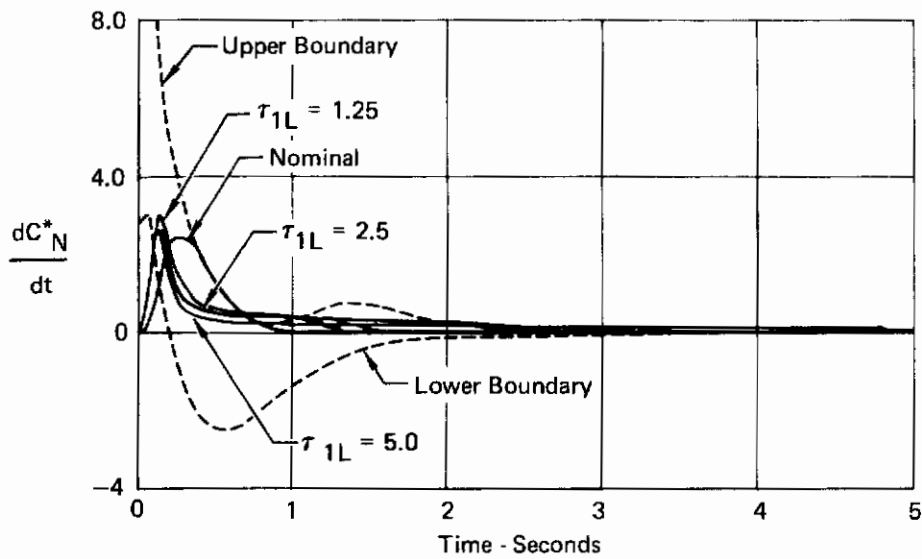
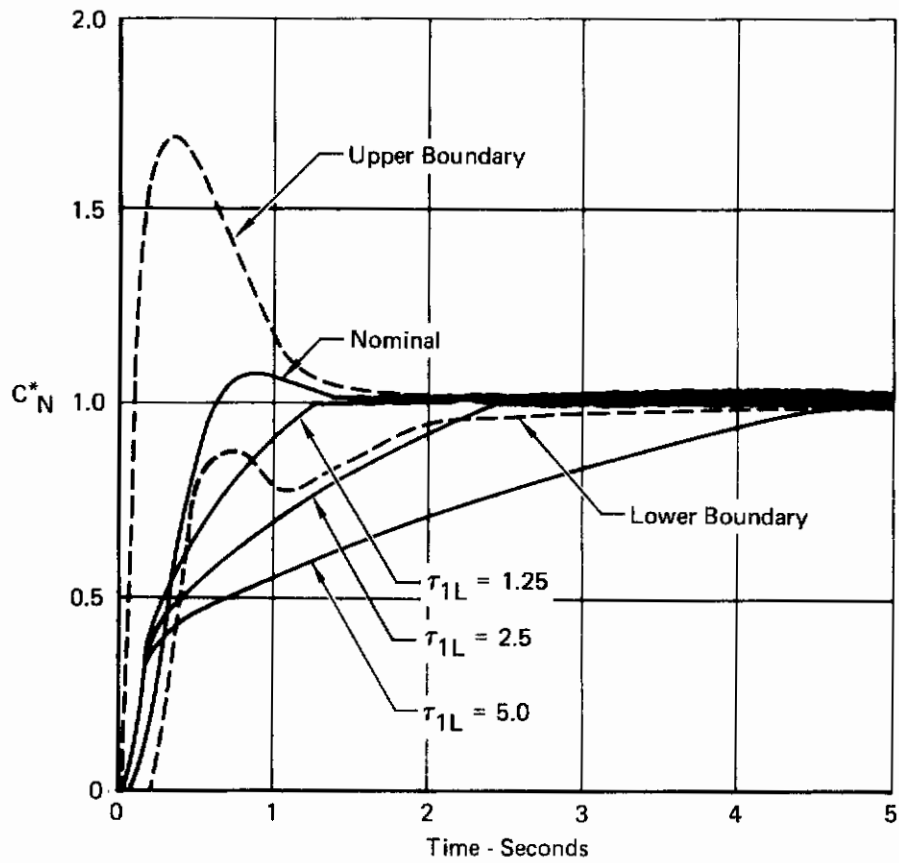

FIGURE 19
LONGITUDINAL TIME HISTORY RESPONSE TRACES
FOR NONLINEAR PREFILTER CONFIGURATIONS

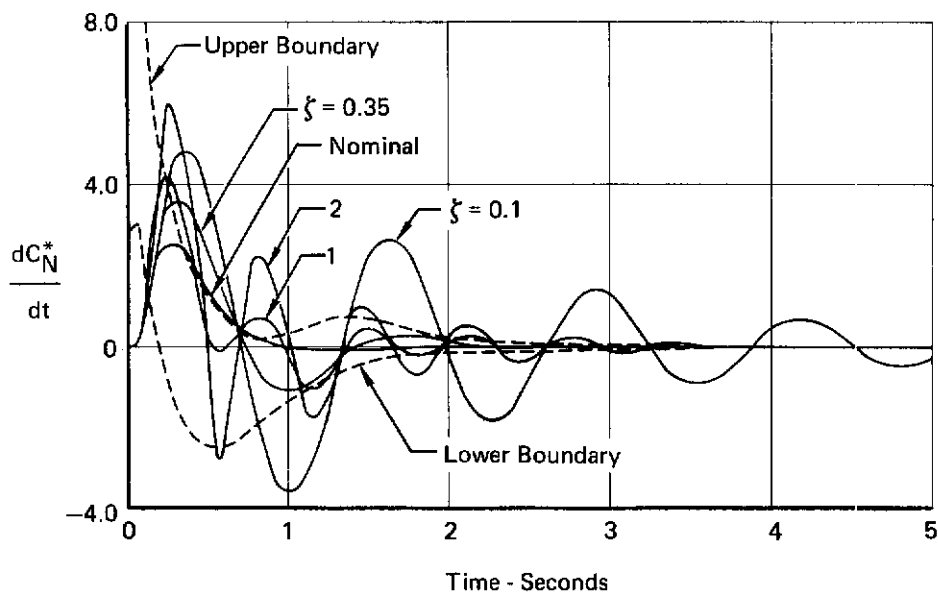
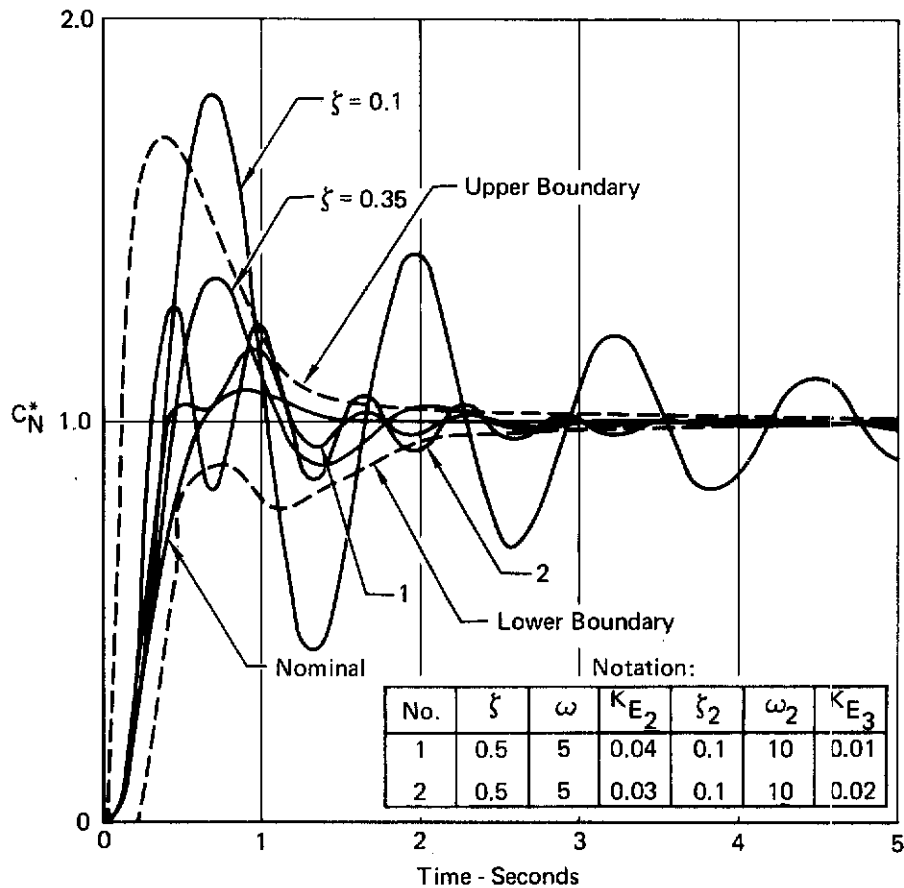

FIGURE 20
LONGITUDINAL TIME HISTORY RESPONSE TRACES
FOR HIGHER ORDER PREFILTER CONFIGURATIONS

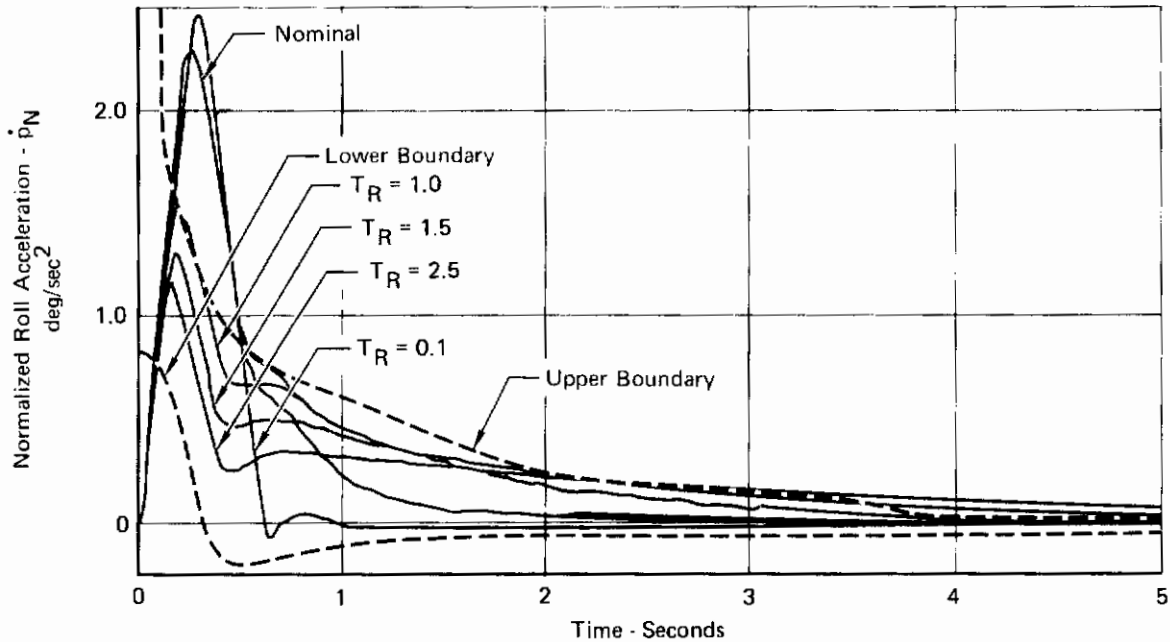
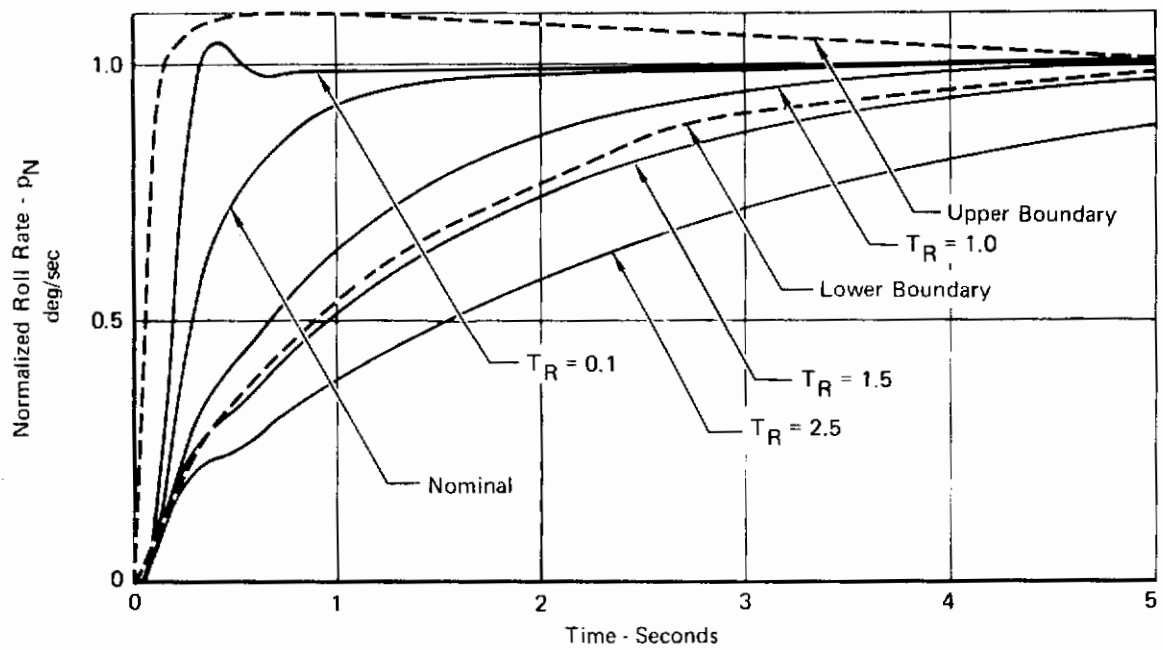

FIGURE 21
LATERAL DIRECTIONAL TIME HISTORY RESPONSE TRACES FOR ROLL TIME CONSTANT CONFIGURATIONS WITH AILERON STEP INPUT

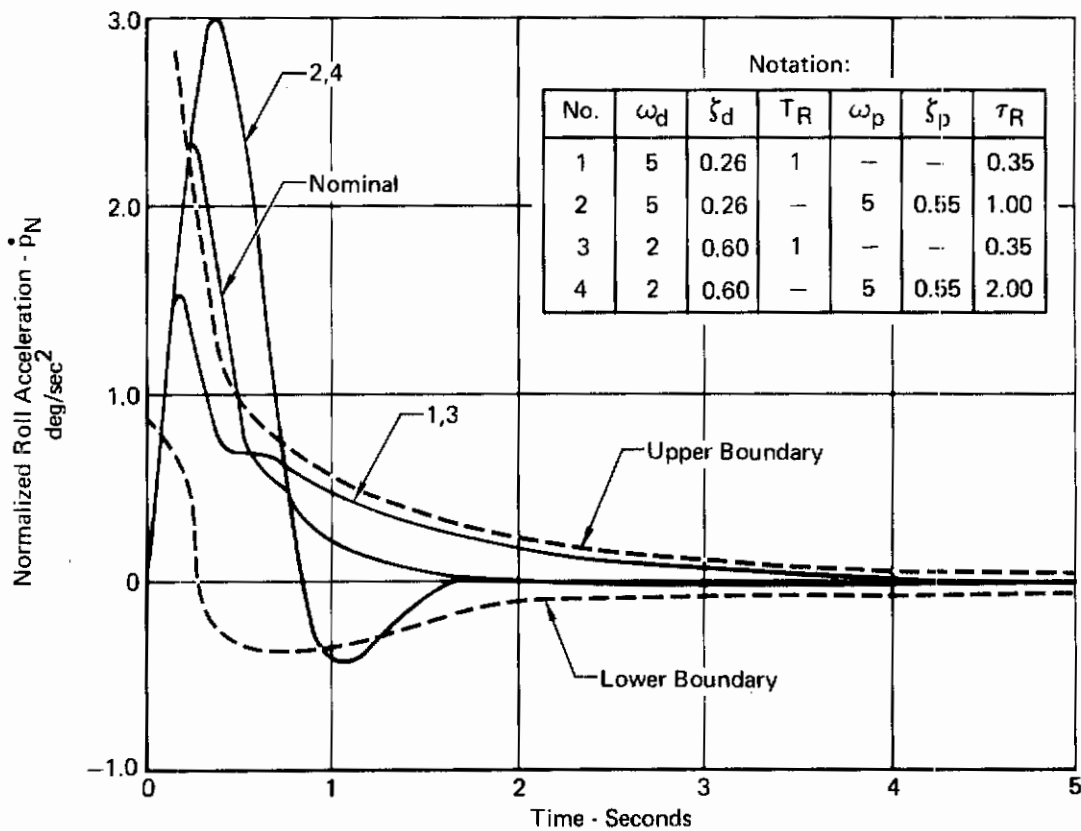
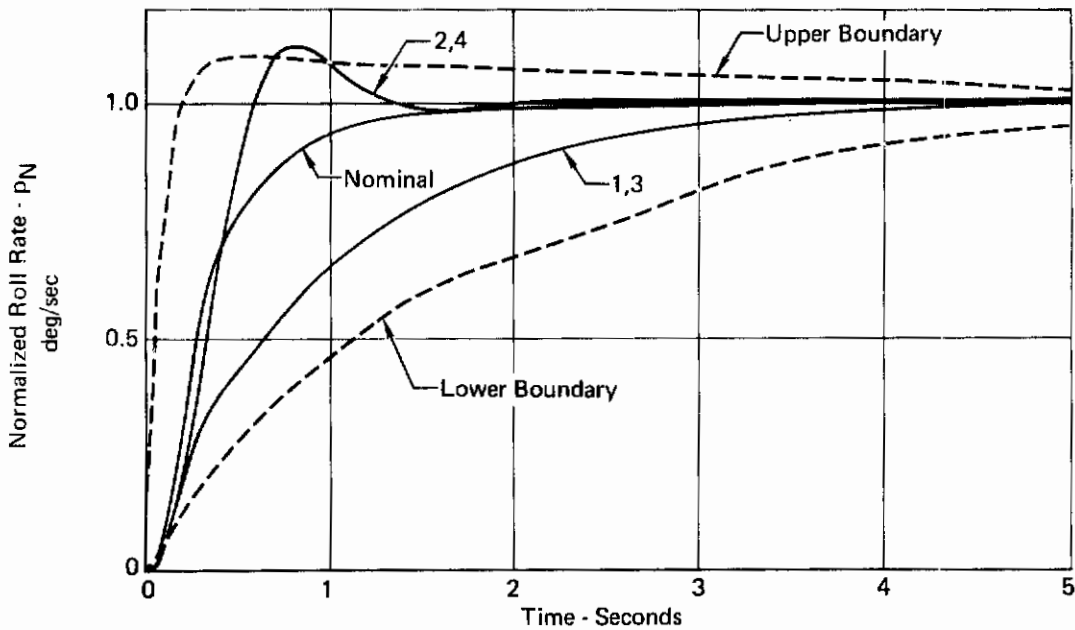

FIGURE 22
LATERAL DIRECTIONAL TIME HISTORY RESPONSE TRACES FOR
DECOUPLED CONFIGURATIONS WITH AILERON STEP INPUT

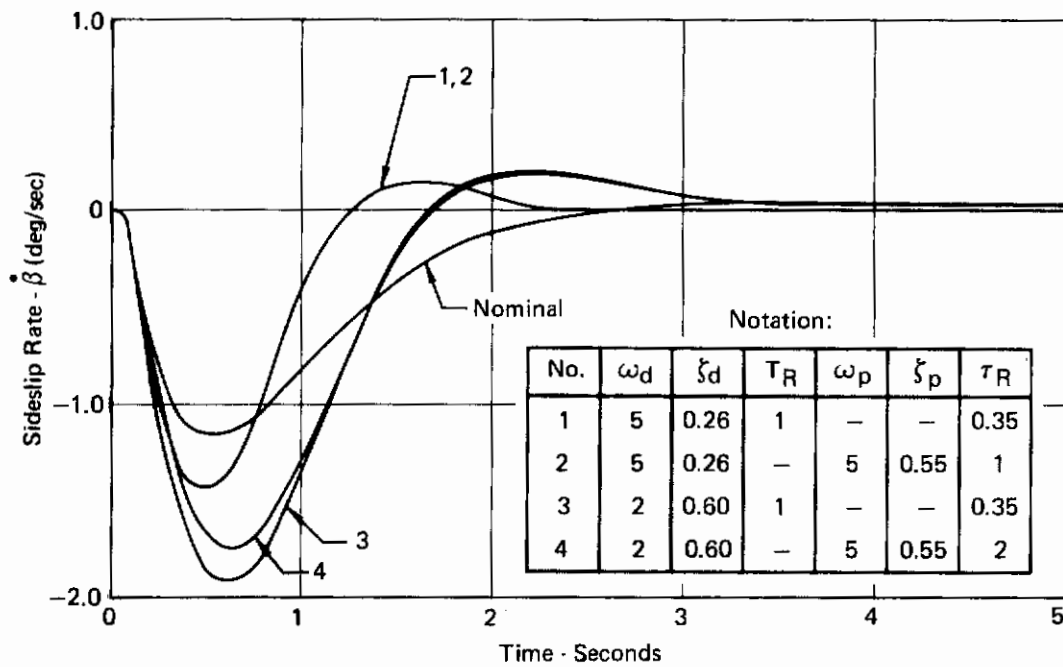
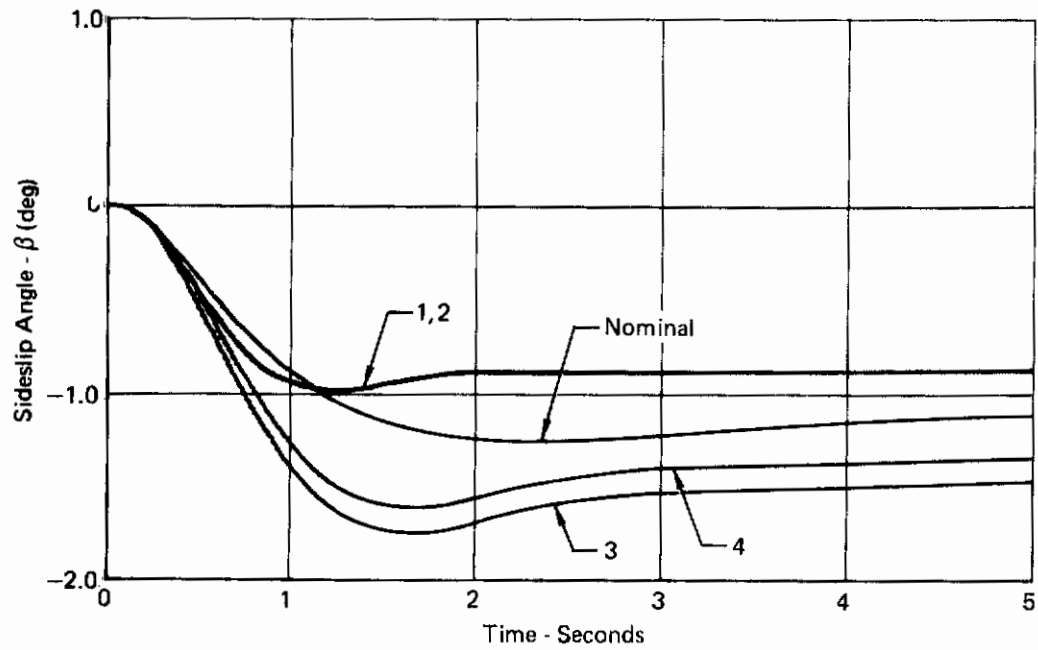

FIGURE 23
TIME HISTORY RESPONSE TRACES FOR DECOUPLED
CONFIGURATIONS WITH RUDDER STEP INPUT

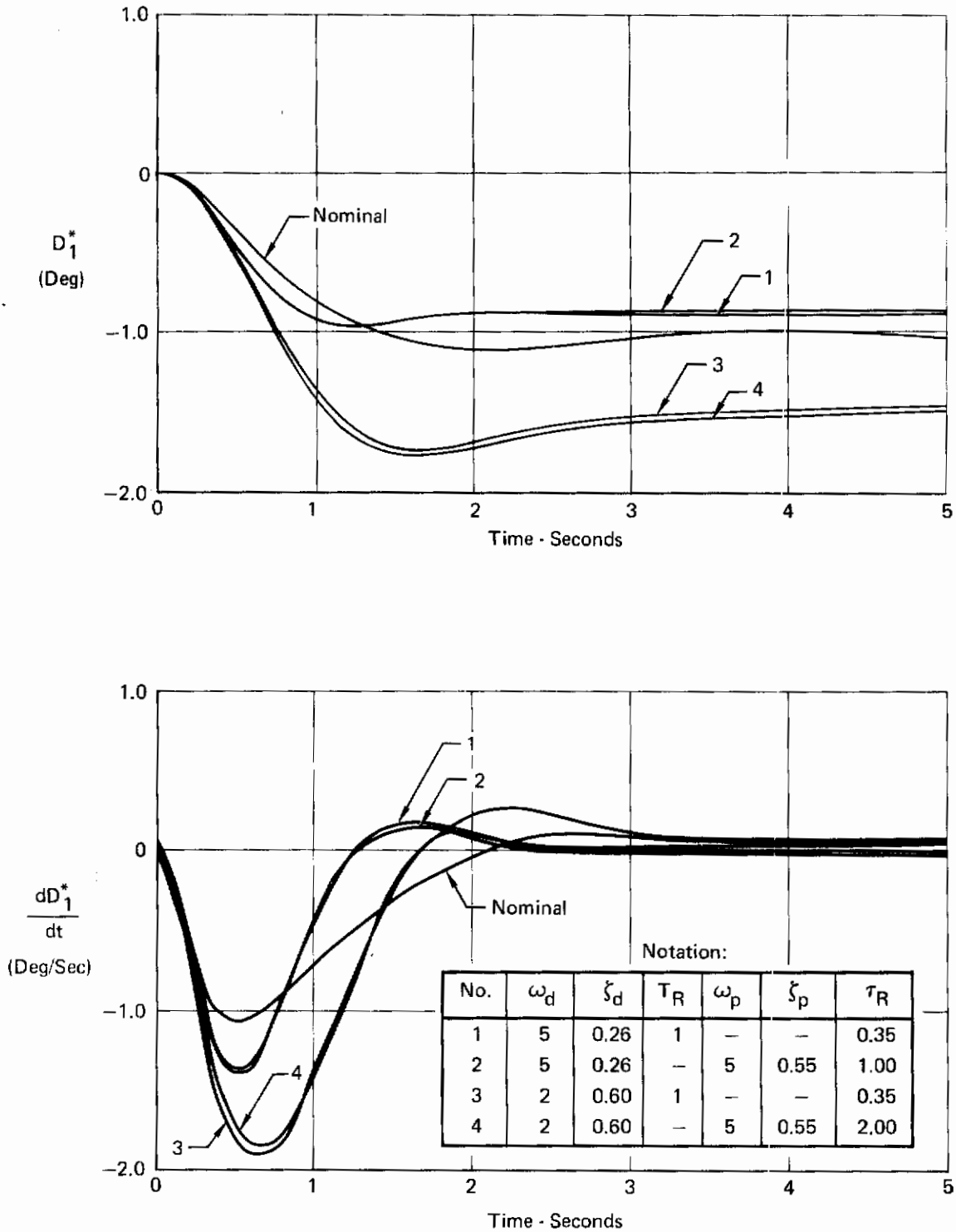

FIGURE 24

**LATERAL DIRECTIONAL TIME HISTORY RESPONSE TRACES FOR
DECOUPLED CONFIGURATIONS WITH RUDDER STEP INPUT FOR $K_3 = -1.95$**

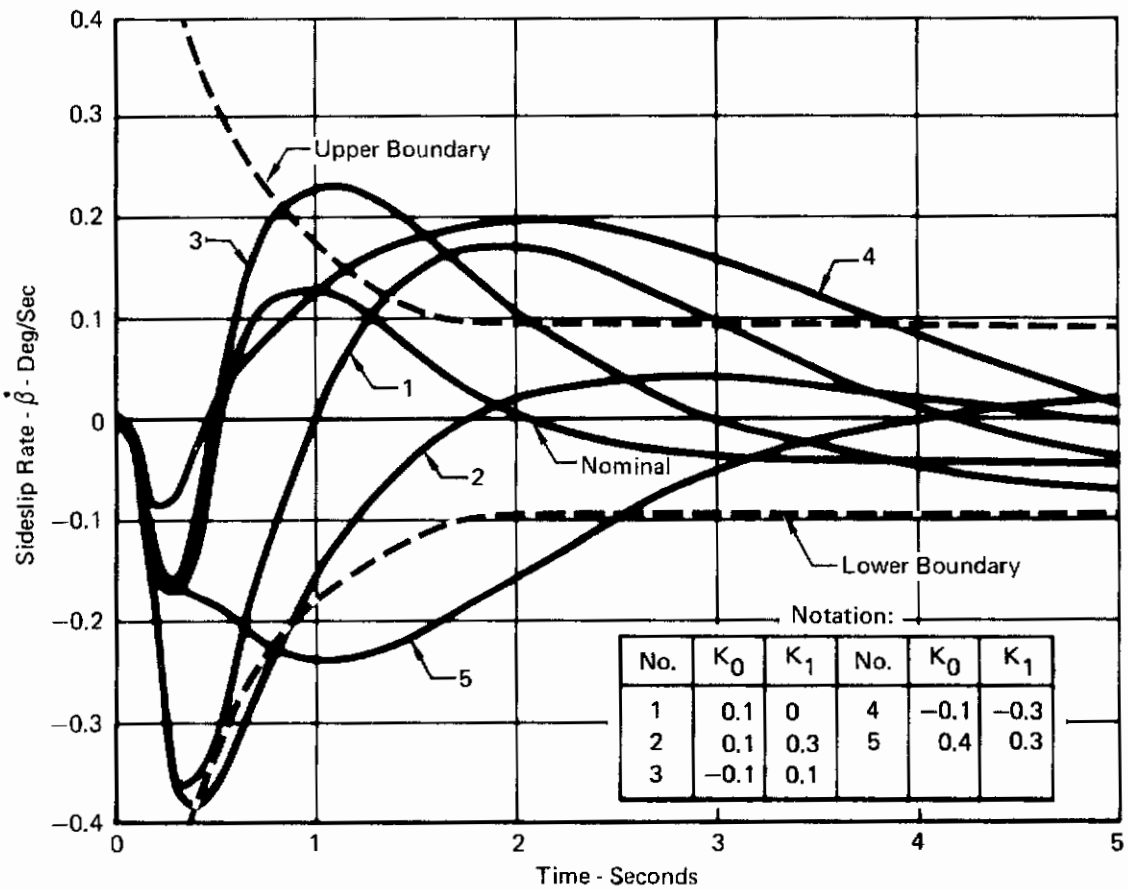
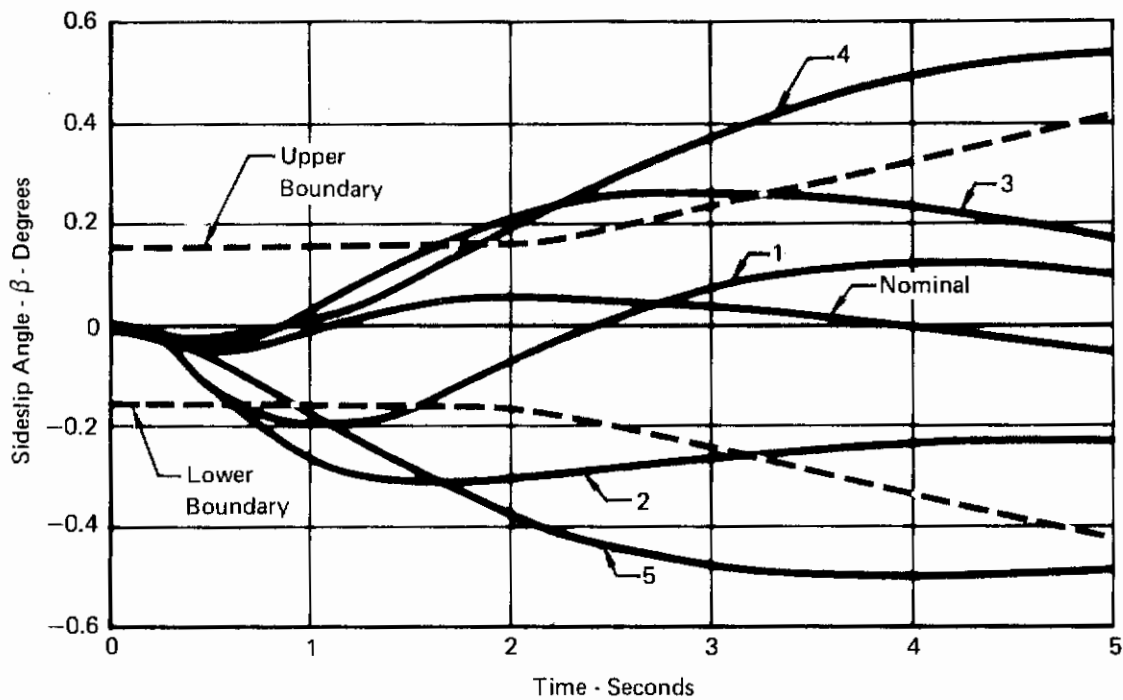

FIGURE 25
TIME HISTORY RESPONSE TRACES FOR ADVERSE/PROVERSE
YAW CONFIGURATIONS WITH AILERON STEP INPUT

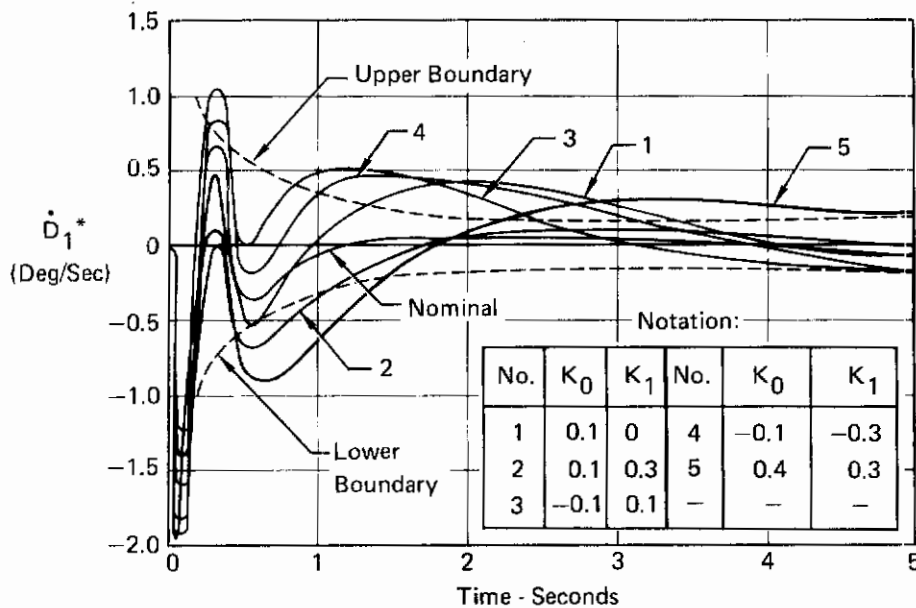
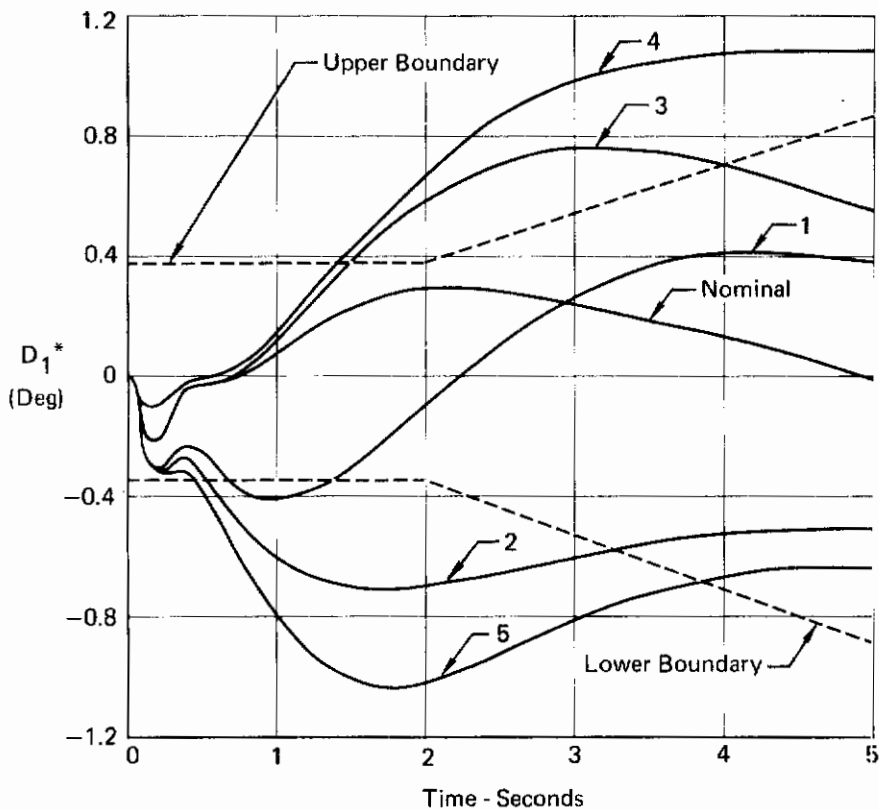

FIGURE 26
LATERAL DIRECTIONAL TIME HISTORY TRACES FOR ADVERSE/PROVERSE
YAW CONFIGURATIONS WITH AILERON STEP INPUT

4. SCORING AND DATA RECORDING

The development of the candidate performance criteria for the SFCS project required extensive use of man-in-the-loop simulation for evaluation of the handling quality characteristics associated with the configurations described in the Simulation Mission and Test Configurations Section. The performance indicators used to rate each configuration included a solicited COOPER-HARPER rating, Table VI, with pilot comments and the assessment of statistical data generated in the form of histograms, cumulative distribution functions, figures of merit, and pilot effort indexes. In addition, continuous time histories of certain parameters were recorded on analog strip charts. The strip chart records were used to monitor the runs in progress and to supplement, when necessary, the COOPER-HARPER ratings and the statistical measurement data.

In each scored mission phase the pilot first had to meet the scoring entry requirements, listed in Table V, in order to activate the scoring light which flashes when all the initial requirements are met. Computations in the digital program were processed when the scoring button was pressed in the crew station by the pilot. In the air-to-air combat mode, the scoring was started automatically as soon as all conditions were met.

Indication to the pilot that digital performance data was being generated was provided with the solid (non-flashing) illumination of the scoring light. Fixed computational intervals were used for the LAHS phase, reconnaissance phase, and the air-to-air combat phase. For these three phases the scoring interval lengths were 50, 30 and 60 seconds, respectively, and the scoring was terminated automatically at the end of the interval.

In weapon delivery and in ground attack the scoring interval was terminated by the pilot. In weapon delivery the scoring was terminated when the pilot pressed the bomb button and in ground attack the scoring was stopped when the pilot pressed the trigger.

a. Histograms

Histograms were generated by programming the CDC 6600 Digital Computer to count the number of times a varying parameter was within a given range. Histogram plots in Appendix V show the number of counts per interval versus the number of intervals for Configuration 1.01 which corresponds to the NOMINAL case values as shown on Page 45. The sampling of parameter values, sorting into bins (intervals), and counting of the number of values in each bin were performed in the main digital program while scoring was in progress. During weapon delivery and ground attack phases, the sampling was performed on every pass through the main digital program (0.02 seconds); in LAHS and air-to-air combat phases the sampling was performed on every fifth pass (0.1 seconds); and in reconnaissance on every tenth pass (0.20 seconds). The upper and lower histogram limits are specified as computer input data for each scored parameter.

TABLE VI
COOPER-HARPER RATING SCALE

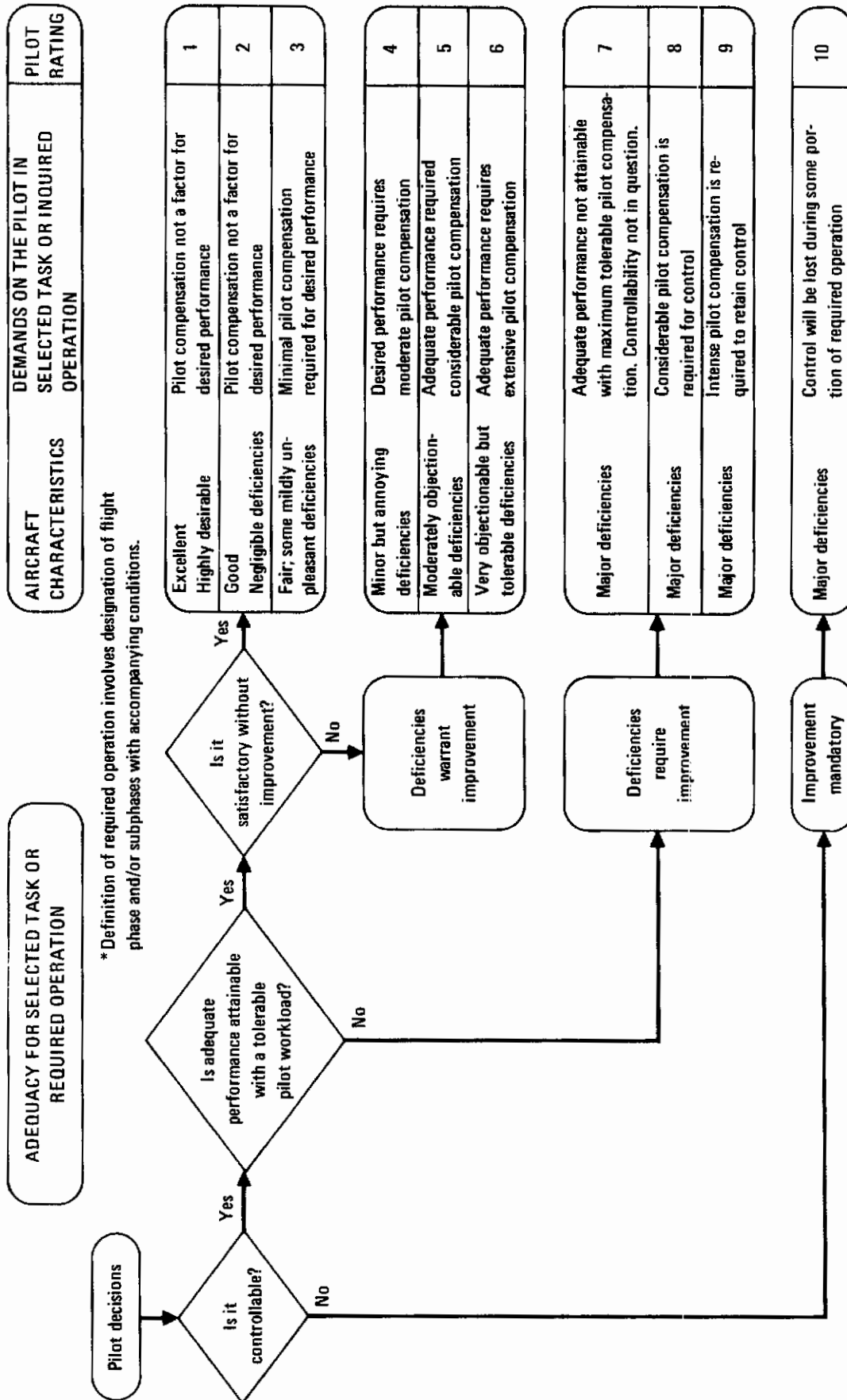

Contrails

After each scoring interval (five times during each run) all the bin count data are buffered out from the main digital computer memory to a disc storage. After one run is completed, or after a series of runs, the disc data are reprocessed by the computer and the printouts containing the histograms, cumulative distribution functions, pilot effort indexes, and figures of merit are generated.

b. Cumulative Distribution

A cumulative distribution plot uses the same abscissa as the histogram but has a modified ordinate, expressed in percentages, representing the summation of counts over all previous intervals plus the number of values falling below the lower histogram limit. When the varying parameter is between its two extreme limits, the cumulative distribution plot ranges between 0 percent and 100 percent. When any parameter values fall below the lower histogram limit, the cumulative distribution function starts on the left at the appropriate value greater than zero, and when any parameter values fall above the upper histogram limit the cumulative distribution reaches less than 100 percent on the right.

c. Figure of Merit

A figure of merit (FOM) is the weighted average of the histogram. The intervals used for computation of FOM were the same as the intervals used for histograms and for cumulative distribution functions. The FOM concept as defined below is a mathematical technique used for transforming time varying data over a given interval into a single number which should be maximized. Selection of this method was based on its single value relationship to specific SFCS design parameters to which performance sensitivity was to be established, and also on its usefulness as a qualitative measure of system effectiveness. As such it is not a final system effectiveness metric such as hit/kill probability parameters for which detailed subsystem descriptions and large amounts of data would have been needed for representative computations. Preliminary estimates indicate that these combat performance parameters can be significantly influenced by:

- o Target
 - 1) Vulnerability
 - 2) Maneuvering capability
 - 3) Manned or unmanned

- o Gun System
 - 1) Dispersion error
 - 2) Bias error
 - 3) Caliber and firing rate
 - 4) Bullet dynamics

- o Optical sight

Contrails

Due to this complexity, the above factors are only included when absolute system effectiveness is to be determined with a specific weapon system against a specific threat. One disadvantage of the FOM approach in application to the present study, is that use of more complex imprecise or simplified math model representation of the above systems could hide the sensitivity characteristics and complicate contemplated testing of selected configurations. Generalization of results to other mission mode tasks is also more difficult if absolute values are used.

FOMs for Azimuth error, elevation error, total angular error, and range were used to establish quality of tracking performance in the CO mode of operation. Mode initiation during simulated mission and pilot familiarity with canned target maneuvers were such that relatively constant range values resulted during target tracking maneuvers and no significant sensitivity trends were evident from the FOM range data. Total angular error is defined as the square root of the summation of elevation error squared and Azimuth error squared which in turn are defined as the aim error of the aircraft in elevation and Azimuth direction respectively. As longitudinal and lateral-directional configurations were tested, maximum sensitivity was realized in these two key parameters, therefore they were used for final data documentation. Variations in these parameters represents variations in "time in desired envelope" characteristics which are qualitatively related to the absolute system effectiveness because improvement in FOM values will improve absolute effectiveness but no specific amount can be quoted unless a detailed hit/kill probability model is formulated and used.

$$FOM = \sum_{i=1}^{21} \frac{21-i}{20} h_i$$

where h_i is the fraction of the total occurrences during which a parameter's magnitude falls into the i -th interval. The weighting coefficients used for all other parameters resulted in a FOM defined as:

$$FOM = \sum_{i=1}^{11} \frac{i-1}{10} h_i + \sum_{i=12}^{21} \frac{21-i}{10} h_i$$

where the meaning of i and h_i is the same as for the first FOM.

d. Pilot Effort Index

A measure of the pilot effort required to accomplish the given task in each mode is defined as the product of pilot applied stick force in each axis times the corresponding stick deflection. The multiplication is performed separately for the longitudinal and lateral channels and the absolute values of the two products obtained are

TABLE VII
SCORING PARAMETERS APPEARING ON PRINTOUT PLOTS

Phase (Mode)	Histogram Parameters				Cumulative Distribution Parameters (CD)	Figure of Merit (FOM)	Longitudinal and Lateral Effort Index
	1	2	3	4			
LAHS	Pitch Error Needle	Roll Error Needle	—	—	Same as Histogram Parameters	One Value of FOM for Each Histogram Parameter	One Value of Longitudinal PEI and Lateral-Directional PEI for Each Phase (Mode)
WD	Elevation Angle Error	Azimuth Angle Error	Sideslip Angle	Angle of Attack			
RECON	Pitch Angle	Roll Angle	Yaw Angle	Altitude			
GA	Elevation Angle Error	Azimuth Angle Error	Total Angle Error	Sideslip Angle			
CO	Elevation Angle Error	Azimuth Angle Error	Total Angle Error	Range			

integrated over each scoring interval. The results are identified as longitudinal and lateral Pilot Effort Indexes and are shown in the top right corner of the printout plots.

e. Printout Plots

The above described scoring techniques were correlated to the pilot task parameters for each mission mode and a selected set of parameters to be scored was chosen. A summary of the mission modes with scored parameters is shown in Table VII. The corresponding examples of digital computer printout plots which were generated on-line for each simulation flight are presented in Appendix V. A separate set of these plots was generated for each pilot and for every configuration flown in the simulator.

f. Strip Chart Records

Strip chart records were made of all phases of the simulated mission. The recorder data were used in initial checkout of the hybrid simulation and in the real-time monitoring of the simulation runs. The strip chart format provided the capability for continuous recording of a relatively large number of parameters, combined with the advantage of flexibility when changing the parameters to be recorded. The strip chart time history data were also useful for correlation with COOPER-HARPER ratings and helpful in assessment of pilot performance as documented on the digital printout.

Contrails

Three Brush recorders were used to generate the strip chart records. Longitudinal, lateral-directional, and general flight environment data were recorded on eight channels, as shown in Table VIII. In addition, two recorders show discrete ON-OFF data spaced between the continuous channels. Four of the signals, representing longitudinal and lateral stick forces, the rudder pedal force, and the throttle angle, were available as DC voltages in the crew station and were recorded without having to pass through the digital computer. All the other continuous and discrete parameters were transmitted from the digital computer to the analog recorders using an Adage converter. Additional information, including a sample set of analog records for all five scored phases in one run, is presented in Appendix V.

g. Tape Recorded Pilot Comments

After each simulation run the pilots were asked to rate separately each scored phase of the run and to comment on their ratings as well as on the general handling qualities of the configuration flown. All the pilot ratings and the associated comments were recorded on tape and transcribed after the study was completed. A summary of representative remarks made by pilots during various test runs is presented in Appendix VII.

5. PILOT PARTICIPATION

Each pilot was given an opportunity to familiarize himself with the hybrid simulation setup after which pilot ratings, comments, and performance data were obtained for the tested configurations. Each pilot was given a set of written and oral instructions describing the piloting tasks as well as the general objectives of the simulation program. The pilots were asked to rate the scored mission phases, and provide comments on the handling qualities simulated in each test configuration.

a. Pilot Experience

Participation in the Control Performance Criteria simulation included three pilots from MCAIR Flight Operation Department and two pilots from the Flight Test Division, USAF, Wright-Patterson Air Force Base, Dayton, Ohio. A summary of the flight time and aircraft type flown by each pilot is presented in Table IX. Each pilot had previous hybrid simulation experience during handling qualities studies.

b. Testing Procedure

The fixed base crew station was located in a separate room adjacent to a larger area where the analog and digital computers are located. While the simulation runs were in progress the pilots were generally alone in the darkened crew station room and an intercom system was used for communication.

**TABLE VIII
PARAMETERS RECORDED ON ANALOG STRIP CHARTS**

	Longitudinal Parameters (Recorder No. 1)	General Parameters (Recorder No. 2)	Lateral - Directional (Recorder No. 3)
Channel 1	Longitudinal Stick Force (*)	Pitch Error Needle (LAHS Phase Only)	Lateral Stick Force
Discrete 1	Score Button Light	Mode Number (Bit 1)	—
Channel 2	Pitch Rate	Roll Error Needle (LAHS Phase Only)	Roll Rate (*)
Discrete 2	Longitudinal Trim Activation	Mode Number (Bit 2)	—
Channel 3	Pitch Angle	Range	Roll Angle
Discrete 3	—	Mode Number (Bit 3)	—
Channel 4	Normal Acceleration at Pilot Station	Longitudinal Pilot Effort and Lateral (*) Pilot Effort	Lateral Acceleration at Pilot Station
Discrete 4	Bomb/Trigger Button	Mode Number (Bit 4)	—
Channel 5	Angle of Attack	Bobweight Force	Sideslip Angle
Discrete 5	Pilot Number (Bit 1)	Lateral Trim Activation	—
Channel 6	Elevation Angular Error (*)	Throttle Angle	Rudder Pedal Force
Discrete 6	Pilot Number (Bit 2)	Directional Trim Activation	—
Channel 7	Azimuth Angular Error (*)	Altitude	Yaw Rate (*)
Discrete 7	Pilot Number (Bit 3)	Speed Brake Activation	—
Channel 8	Calibrated Velocity	Mach Number	Yaw Angle

* . . . Asterisk indicates parameters which were not recorded in the air-to-air combat phase.

Contrails
TABLE IX

PILOT EXPERIENCE SUMMARY

Type of Aircraft	Number of Pilots				
	MCAIR			USAF	
	1	2	3	4	5
Jet Fighter	3800	3000	4800	2500	3200
Other	200	300	500	100	205

At the start of documentation running, each pilot was given the opportunity to fly as many practice runs as desired. Typically, four to six practice runs were sufficient for familiarization with simulated mission and pilot tasks involved.

Documentation runs were usually made in sets of five to seven runs with average duration of eight to ten minutes for each run. In cases when the pilots flew consecutively more than one set of runs, break periods were taken between the sessions. The mission phases and the piloting tasks remained unchanged for all documentation runs, while the simulated configuration with the associated handling qualities was changed from one run to the next. Between the simulation runs the pilots spent, on the average, two to three minutes providing ratings and comments as described below.

c. Pilot Briefing and Questionnaire

The documentation pilots were given written instructions which included a description of the purpose of the study, an outline of the simulation plan, and a description of the piloting task as presented in Appendix VI. Pilots received copies of the mission plan, Table V, and a table identifying the COOPER-HARPER, Table VI ratings as adapted from a figure in Reference 8. In addition, any related questions the pilots had were answered before and during the simulation.

The documentation runs were made in sequences of two to six runs where only the longitudinal or only the lateral-directional handling qualities were varied.

At the completion of each documentation run the pilots were requested to give a separate COOPER-HARPER rating for every scored phase of the simulated flight and to comment on the handling qualities. A questionnaire, Figure 27, was prepared and given to pilots to be used to aid in formulating their ratings and comments. The questionnaire was used by the pilots as a guideline in preparing their answers which were recorded on tape for later evaluation.

Pilot _____ Date _____

Configuration _____

Provide Cooper-Harper (CH) Rating for:

1. Phase (Mode): LAHS WD RECON GA CO

CH Rating _____

2. Comment on handling qualities and relate their effect on accomplishment of pilot task in applicable mission mode:

Longitudinal

- (a) Short Period Response
- (b) Maneuvering
- (c) PIO Tendencies
- (d) Control in Dives
- (e) Tracking
- (f) Precision Flying
- (g) Turbulence
- (h) Stability
- (i) Other

Lateral-Directional

- (j) Dutch Roll Oscillations
- (k) Roll Rate Response
- (l) Sideslip Response
- (m) Lateral Acceleration
- (n) Turn Coordination
- (o) PIO Tendencies
- (p) Control in Dives
- (q) Turbulence

3. Comment as desired:

FIGURE 27
PILOT QUESTIONNAIRE

Contrails

SECTION VII

SIMULATION RESULTS

Pilot ratings and scoring data obtained during the simulation were plotted in parametric form to show how test configurations described in Section 3.6 affected accomplishment of outlined mission mode tasks. Flight control system block diagrams are shown in Figures 13 and 14, and associated switching mode data is presented in Figures 17 through 26. Comments reflecting pilot opinion of handling quality characteristics as determined by individual test configurations are presented in Appendix VII. Documentation data presented in Figures 28 through 34 show results of hybrid simulation testing as plotted against the parameter variations investigated during the analysis phase. The data is arranged horizontally according to the sequence of five mission modes (LAHS, WD, RECON, GA, and CO) tested during the man-in-the-loop simulation and vertically according to the measures (CH ratings, FOM for longitudinal task parameters, and center stick PEI) used in assessment of pilot performance. Data points shown in the figures are arithmetic averages of values generated by all five participating pilots with one or more runs per configuration. An overall average of four run values were used per plotted data point shown with this value increasing to 10 for the nominal case. Some test subject variation was experienced during the simulation phase. The variation was significant during the initial portion of pilots' learning curves as evidenced during evaluation phase. Increased exposure to the hybrid simulator mission and repetition of associated tasks reduced this variance significantly by the time documentation data was taken.

Side Stick Controller operation and usage as described in Section VI resulted in qualitative evaluations which were in support of simulation results shown in this section. Pilot comments and investigation results (CH rating) indicate that SSC usage lowers the pilot physical work load significantly and makes the flying task in all mission modes much easier. The handling quality characteristics, as measured by FOM, desired by pilots in conjunction with SSC operation appear to be equivalent to those for center stick operation and mechanization of SFCS as described in Supplement 2 shows no control law feedback changes with its usage.

1. LONGITUDINAL TEST CONFIGURATIONS

Pitch axis handling qualities were modified with variations in prefilter time delay, time constant, and quadratic lag characteristics to produce simulated nonlinear and higher order dynamic characteristics. Switching positions called out for each configuration refer to Figures 13 and 14.

a. Time Delay Configurations (Switch 2 only closed)

The nominal configuration with zero time delay and two additional configurations as shown in Figure 17 were investigated during the simulation. The documentation data for all three combinations are shown in Figure 28. The relative height of the FOM and PEI data points are due, in large part, to the selection of digital printout limits shown in Appendix IV. Consequently, the plotted data are useful for establishing relative trends due to parameter variations such as the time delay characteristics, but do not completely reflect the absolute accuracy attainable in a real time combat environment.

Contrails

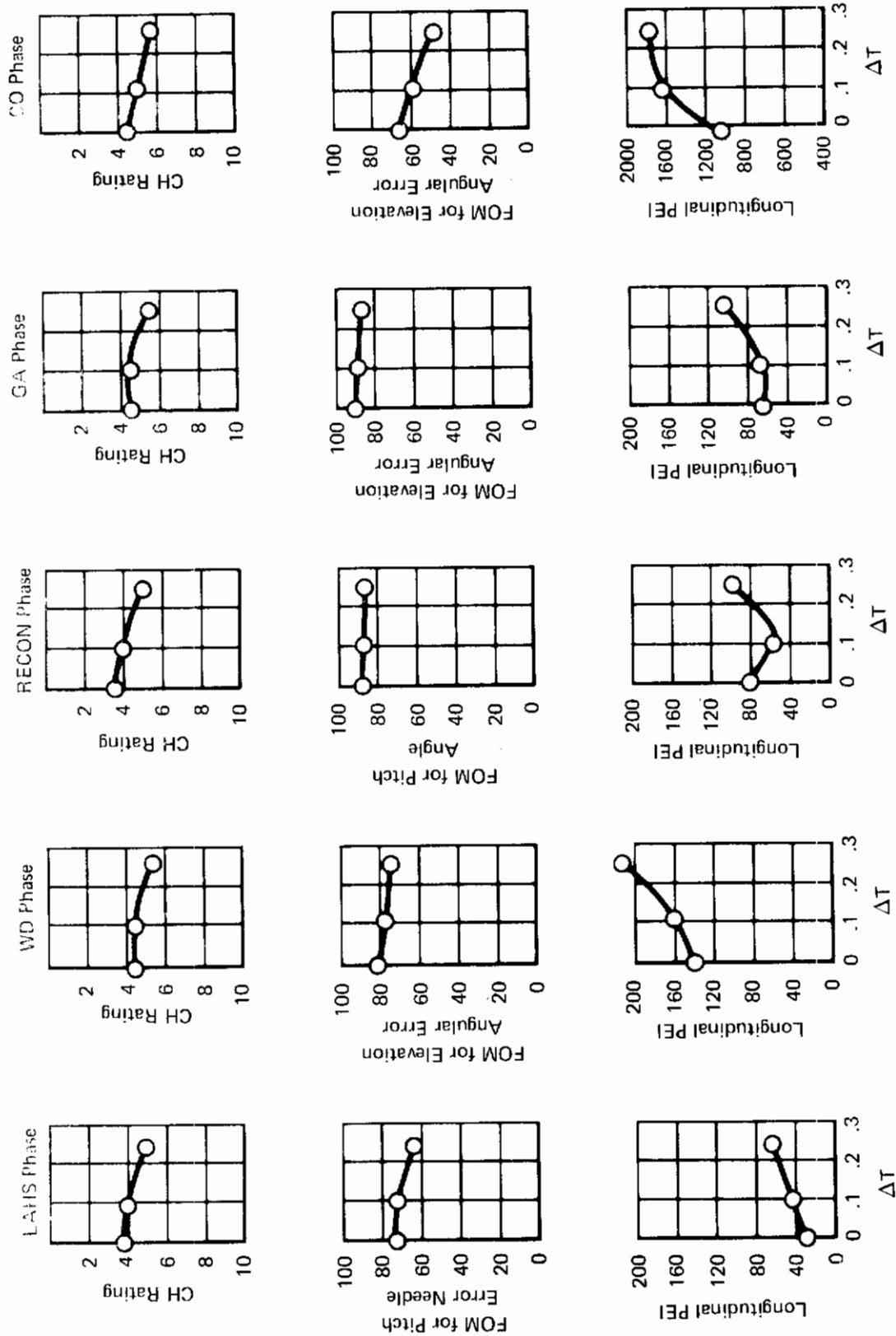

FIGURE 28 PILOT PERFORMANCE DATA FOR TIME DELAY CONFIGURATIONS

Contrails

As can be seen in Figure 28, the most significant trend in time delay variation was realized in the air-to-air combat mode of operation where the longitudinal pilot effort index depicts an increasing value as the delay time is increased. This signifies that the pilot had to work successively harder to maintain minimum tracking error. The pilot ratings show a sharp decrease for the same variation and pilot comments given in Appendix VII indicate unacceptable operation for the maximum value of $\Delta T = 0.24$ seconds. Pilot ratings were highest in the RECON mode with apparent acceptance of the maximum time delay value for this type of control. In all other modes, the longitudinal performance as measured by FOM parameters showed a slight decrease from $\Delta T = 0$ to $\Delta T = 0.1$ seconds and a definite downward trend from $\Delta T = 0.1$ to $\Delta T = 0.24$ seconds. Lateral directional parameters were not exceptionally affected except for the CO mode where some coupling into the roll axis was evident.

b. Time Constant Configurations (Switch 1 only closed)

Pilot ratings obtained during simulation of time constant configurations show similar trends in all modes of operation. The data presented in Figure 29, along with appropriate pilot comments as documented in Appendix VII substantiate a downward trend in the CH ratings for values of T_L greater than 1.0. For lower T_L values, the pilot ratings are relatively constant except in the air-to-air combat mode where pilots felt that lower values yielded poorer performance. Similar trends and consistency are seen in the longitudinal FOM and PEI data where a peaking effect occurs at a T_L value of 0.50. In all modes, the general shape of these performance data correlates well with the pilot ratings as depicted in the air-to-air CO mode except that the peaking effect occurs at a lower value. It is interesting to note that somewhat more coupling into lateral directional motion resulted with these configurations, but the trend in PEI parameters is generally in concert with the longitudinal trends. The lateral performance values are complimentary in all modes except GA (strafing) where a peak reversal resulted in azimuth tracking.

c. Nonlinear Configurations (Switch 4 only closed)

Effects of time constant variations in the pitch axis (nonlinear pre-filter) were evaluated by simulation pilots and the documentation data obtained are presented in Figure 30. Pilot comments of associated handling qualities are given in Appendix VII for each configuration investigated. The performance data and pilot opinions generally reflect a decreasing preference for higher time constant values as demonstrated in all three visual modes of operation. Pilot performance during the nonvisual modes (LAHS and RECON) suffered only slightly, while the CH ratings improved in both modes with a relatively constant pilot effort index for the whole range of time constant variations. It is interesting to note that in these modes, pilot acceptability does not significantly diminish during the rather large variation of time constant values and completion of the terrain following/avoidance tasks, as well as the precision cruise

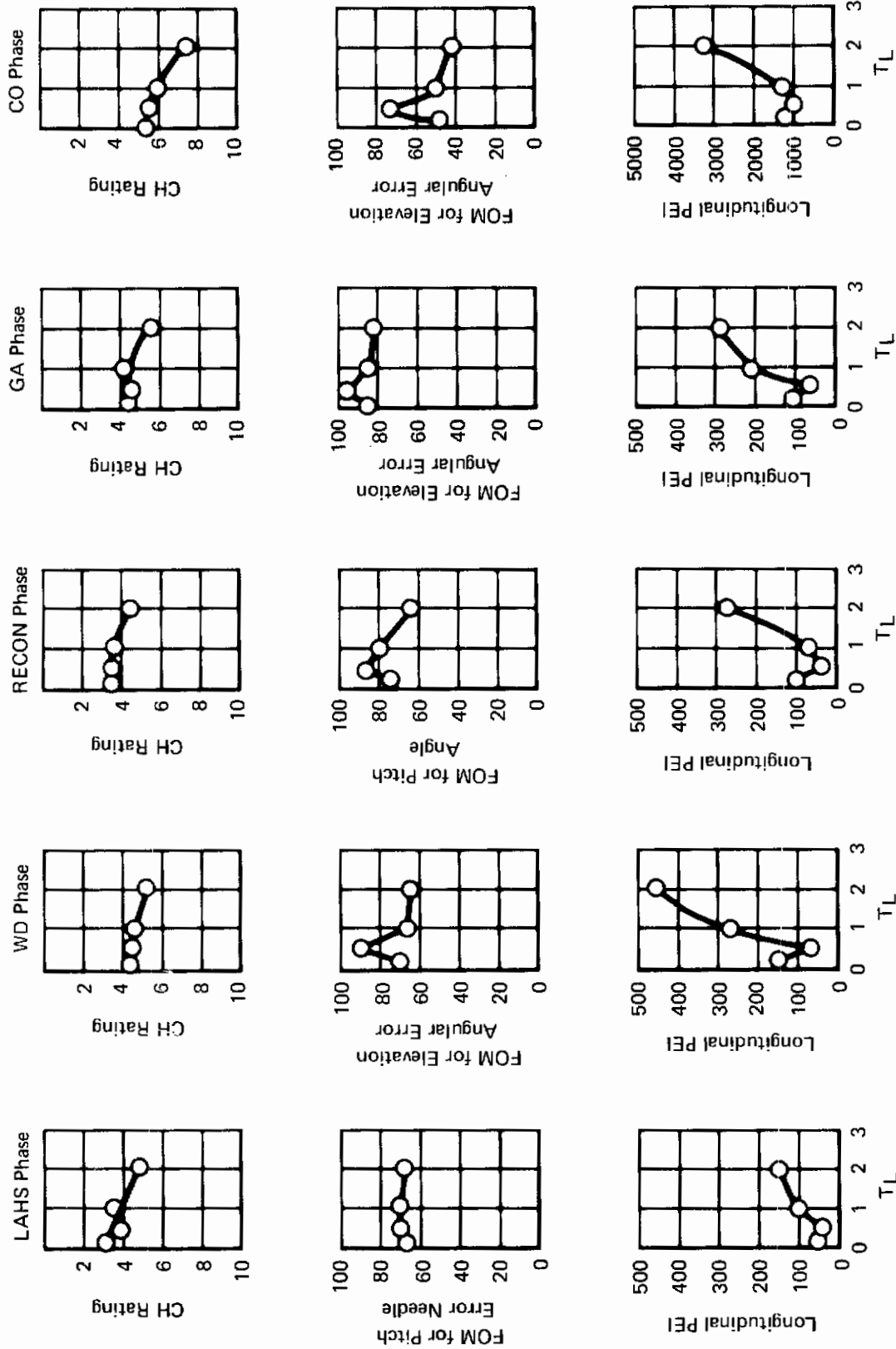

FIGURE 29 PILOT PERFORMANCE DATA FOR PREFILTER TIME CONSTANT CONFIGURATIONS

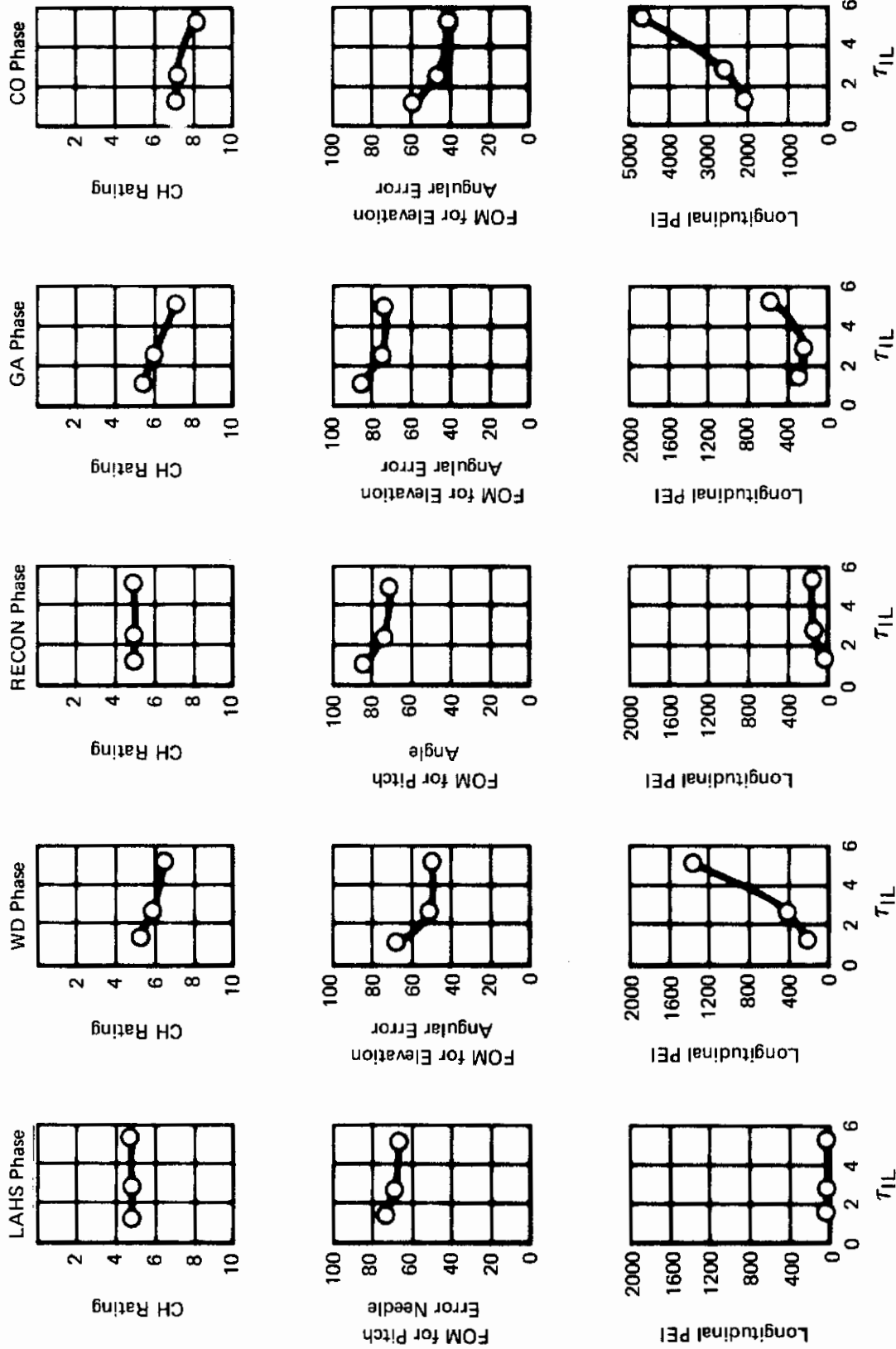

FIGURE 30 PILOT PERFORMANCE DATA FOR NONLINEAR CONFIGURATIONS

Contrails

flight task, are not adversely affected. Some coupling into the lateral-directional axes during these modes of operation was realized with a most noticeable decrease in the FOM at the maximum value of $T_{LL} = 5.0$. The air-to-air combat mode exhibits the greatest variation in performance data with sharp reduction in elevation tracking, and a steep increase in pilot's longitudinal PEI.

d. Higher Order Configurations (Switch 2 and 3 closed)

Pilot ratings were significantly affected by higher order dynamics as seen in Figure 31. The pilot comments presented in Appendix VII for these variations indicate a noticeable sensitivity to low damped oscillatory response characteristics. However, the variation in CH ratings is not entirely indicative of the variation in performance data as seen in the figure. Except for the RECON phase, a relatively constant longitudinal performance level was achieved in each mode of operation. The low ratings reflected an apparent dislike for the simulated higher order characteristics, but pilot flying techniques adequately compensated for these adverse handling qualities to achieve reasonably invariant performance levels. As in previous modes, some coupling into the roll/yaw axes resulted especially in the CO mode where both PEI parameters, show noticeable upward trends.

2. LATERAL-DIRECTIONAL TEST CONFIGURATIONS

Lateral-directional handling qualities were modified with gain variations in the flight control system to produce response characteristics representative of roll time constant variations and degrees of inter-axis decoupling with various levels of adverse/proverse yaw characteristics.

a. Roll Response Configurations (Switch 6 only closed)

Roll response characteristics described in Section VI were investigated during the man-in-the-loop simulation to help establish the roll transient boundaries desired by the pilot for accomplishment of the outlined mission mode tasks. The documentation data shown in Figure 32, along with pilot comments, indicate a general downward trend in the CH ratings, with an accompanying upward trend in the lateral PEI data, for increasing T_R values. Lateral tracking performance is relatively constant throughout the range of variations investigated, indicating that the pilot was able to maintain same level of lateral tracking accuracy for changing values of time constant. Some coupling into the pitch axis is evident in the CO mode where a slight improvement results from sluggish roll axis operation. The relatively minor variation in the task parameter values indicates that pilots were able to maintain the desired level of performance but had to work harder to achieve it. The incremental addition in work resulted in some reduction in the CH ratings as seen in Figure 32. These data tend to support the belief that pilot rating deterioration is not automatically accompanied by a deterioration in performance level as shown in the Figure 32.

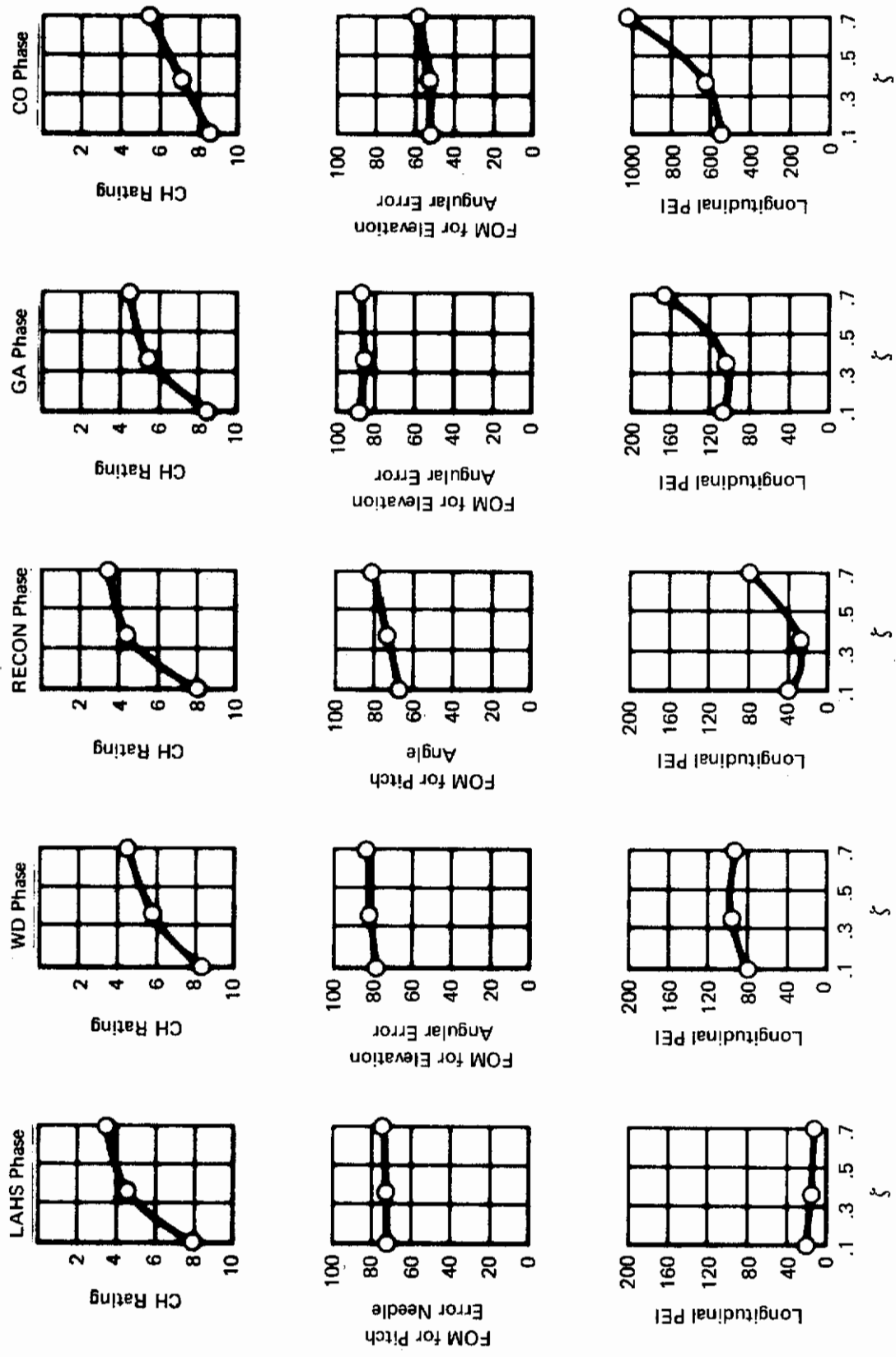

FIGURE 31 PILOT PERFORMANCE DATA FOR HIGHER ORDER CONFIGURATIONS

Contrails

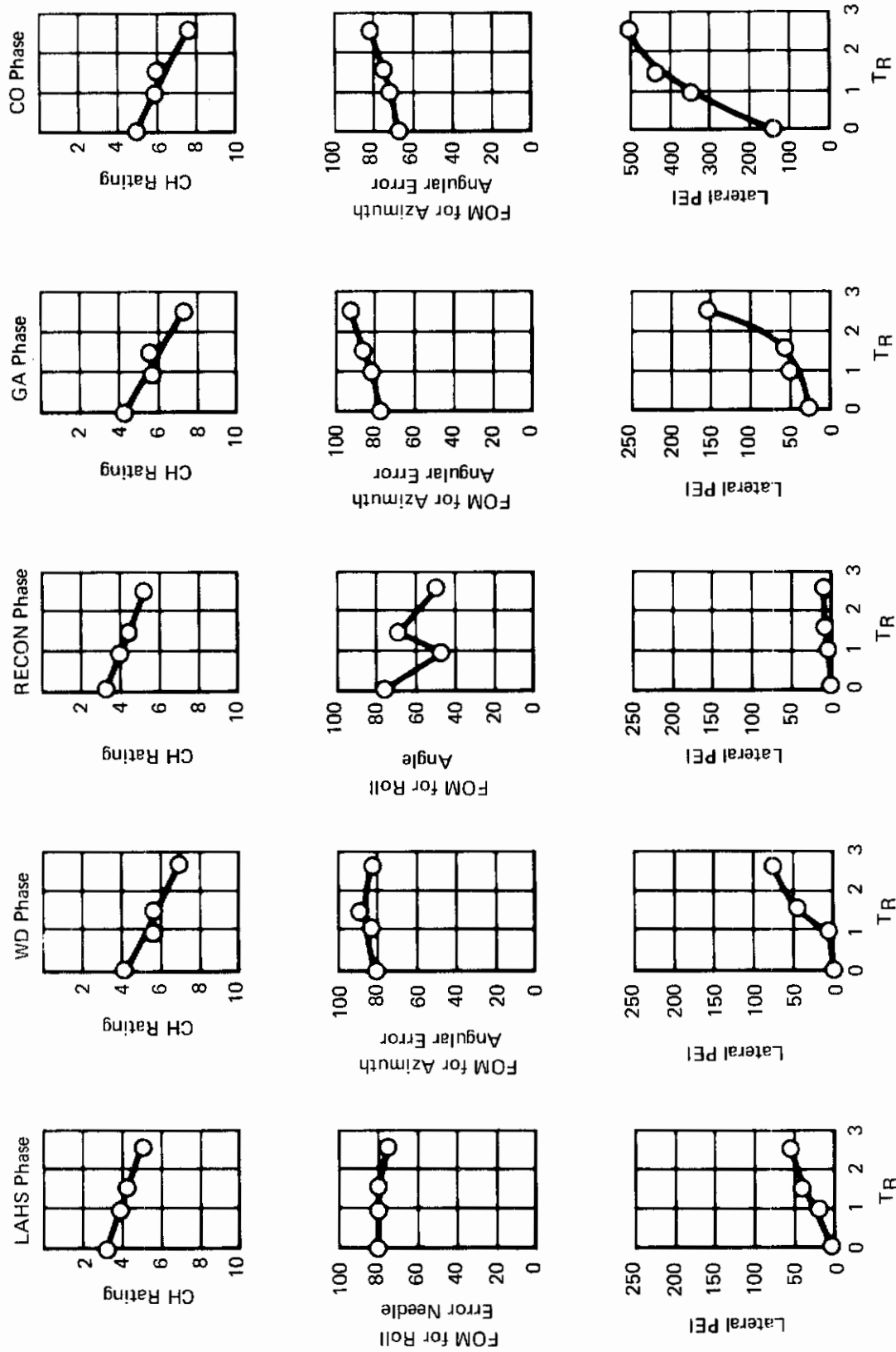

FIGURE 32 PILOT PERFORMANCE DATA FOR ROLL TIME CONSTANT CONFIGURATIONS

Contrails

b. Adverse/Proverse Yaw Configurations (Switch 5 and 6 closed)

Generation of an acceptable D_1^* boundary for use in evaluating directional response characteristics to step force inputs was the purpose for testing selected adverse/proverse yaw configurations. The documentation data obtained during the simulation are a function of roll-to-yaw coupling and are plotted in terms of D_1^* magnitudes at two time points ($t = 1.0$ second and $t = 3.0$ seconds.) Performance data for each scored mission mode are shown in Figures 33 and 34, with pilot comments given in Appendix VII. All configurations shown in Figure 26 are included in the plots of Figures 33 and 34. In Figure 33, the abscissa scale corresponds to the amplitude of the D_1^* transients (Figure 26) at 1 second time, and in Figure 34 the abscissa scale corresponds to the D_1^* amplitude at 3 seconds. For example, in Figure 33 the points with abscissa value of $D_1^* = -0.8$ degrees correspond to configuration number 5 in Figure 26. The data and comments indicate a reduction in pilot ratings for configurations with relatively large D_1^* magnitudes, both positive and negative. This is verified, in part, by the lateral performance data and further evident from pilot PEI variations for each mode. Interpretation of these data indicates that a downward variation in pilot acceptance was realized, with a zero value of D_1^* apparently most desirable. The criterion region appears to be bounded with the configurations tested during the simulation.

c. Decoupled Configurations (Switch 6 only closed)

Data for decoupled configurations as investigated during the simulation were added to Figures 33 and 34 to enable comparison with related information as presented in these figures. FOM values for task parameter and pilot PEI values shown in the figures indicate achievement of performance levels generally equal to those associated with the nominal configuration. In contrast, the pilot ratings were generally lower and significantly lower during the GA and CO modes of operation. The usual correlation of lateral PEI with CH ratings does not seem to be consistent with the decoupled configurations especially during GA and CO. This can be attributed, in part, to pilot flying techniques possibly being altered during the decoupled runs, which resulted in lower ratings.

d. Multiple Variations

The test procedure followed during the simulation consisted of run sequences in which one response characteristic was varied at a time. It was hoped that this approach would provide maximum correlation of pilot performance variation with subject response characteristics being modified. Variation of two or three parameters at a time compounds the process of identification of a candidate criterion and for that reason was not emphasized in the test plan. It was hoped that any flight test follow-on effort would utilize this approach to establish the sensitivity characteristics of the proposed criteria. From study results, it is felt that if slightly off-nominal values were considered in multiple combinations the results would not be significantly different from those shown from the nominal case.

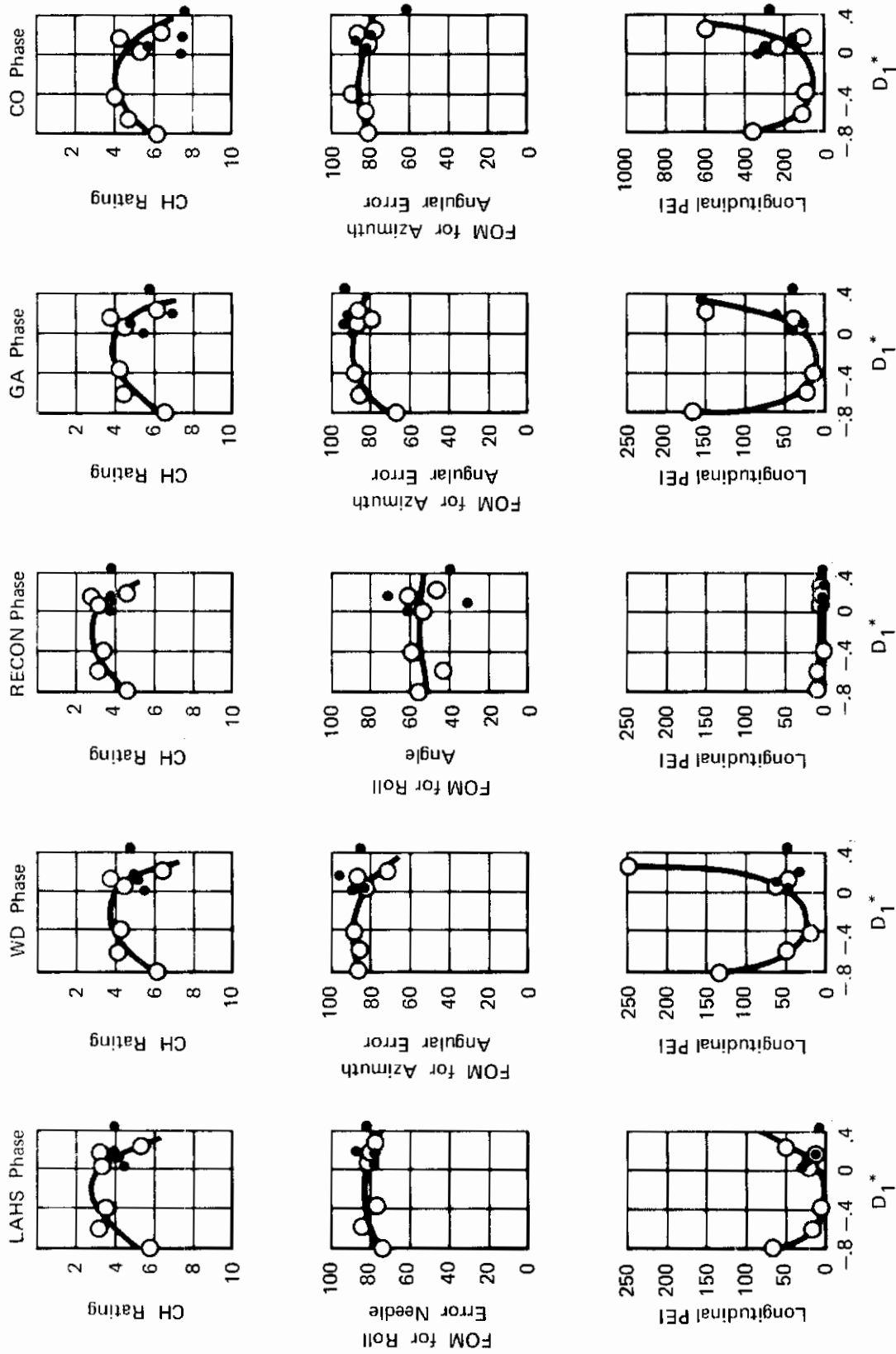

FIGURE 33
 PILOT PERFORMANCE DATA FOR ADVERSE/PROVERSE YAW CONFIGURATIONS (o) AND DECOUPLED CONFIGURATION (●) PLOTTED vs D_1^* MAGNITUDE AT t = 1 SECOND

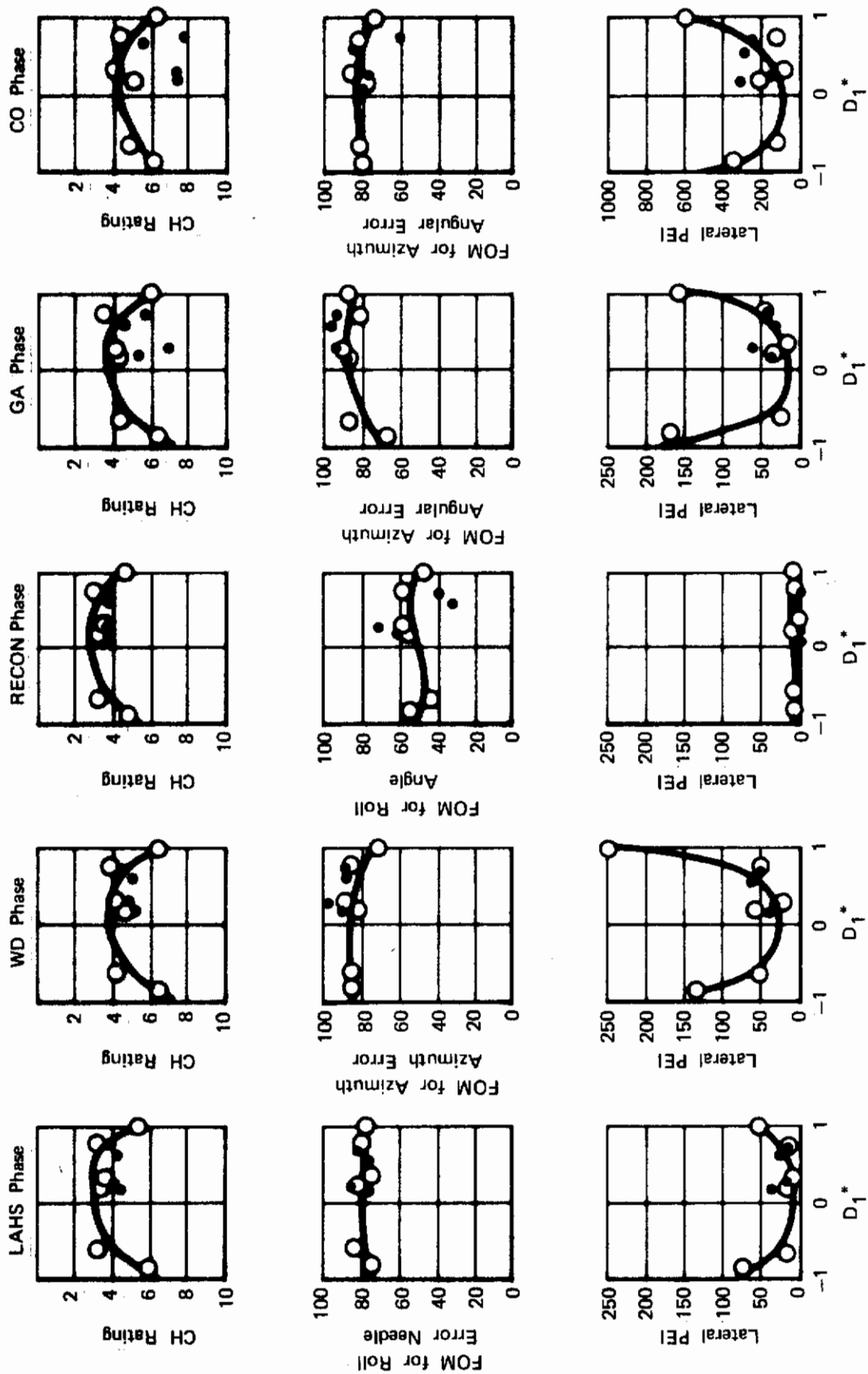

FIGURE 34
 PILOT PERFORMANCE DATA FOR ADVERSE/PROVERSE YAW CONFIGURATIONS (○)
 AND DECOUPLED CONFIGURATION (●) PLOTTED
 vs D_1^* MAGNITUDE AT $t = 3$ SECONDS

Contrails

Intuitively, if more extreme cases of longitudinal, lateral and directional response characteristics were varied in pairs of two or three, the degradation would not be linearly proportional but definitely worse than the equivalent data shown for one parameter variation.

3. RECOMMENDED CRITERIA

Documentation data from hybrid man-in-the-loop simulation effort as shown in Figures 28 through 34 was crossplotted to determine variation of pilot rating with mission modes investigated. Results are presented in Figure 36 and show the CH rating data in equivalent curve form for six categories of design parameter variations tested during the hybrid simulation. General trend in the data indicates consistently lower ratings in all modes of operation for limiting design parameter values (low damping, high T_R values, high T_L values etc.) with little or no crossing of the curves from mode to mode. For these design parameter values, low ratings (high CH values) are generally low in all modes. High ratings such as those associated with the nominal case are rated high (low CH values) in all modes and many times grouped with equally high rated configurations which also fall into acceptable areas of the candidate criteria. Since no clear trend is evident in the data in the form of alternating high and low values for the design parameters, it is concluded that the performance criteria need not be based on mission modes but rather on short period handling qualities criteria as described in this report. CH ratings tend to be better for less demanding tasks and poorer for more demanding tasks. Tasks such as takeoff and landing or in-flight refueling which were not included in this investigation may benefit from some change in control law.

Documentation data from man-in-the-loop simulation resulted in modification of the performance criteria candidates as formulated during analyses and studies.

Pitch axis configurations tested helped establish a revised shape for the C^* criterion envelope and the C^* rate of change requirement was modified to be more effective against undesirable response characteristics. Modification of the C^* criterion included elimination of the initial time delay characteristics and the reduction of the lower boundary in the time interval between 0.5 sec. and 1.0 sec. as shown in Figure 35. The latter change was possible since favorable documentation data were obtained during investigation of nonlinear and time constant variations. As a consequence of the higher order investigations the boundaries of the rate of change requirement were modified and positive response rates between $t = 0$ and $t = 0.2$ sec now fall into the acceptable area. The envelopes of acceptability shown in Figure 36 constitute the recommended performance criteria for use in the evaluation of the SFCS pitch axis flight control system. A comparison of the recommended criterion with the candidate and original C^* boundaries is shown in Figure 37.

Pilot comments indicated that roll time constant values near $T_R = 0.5$ were most desirable for good lateral maneuvering and control. Acceptability of roll time constant variations tested during the fixed base simulation appeared to be marginal for values greater than $T_R = 1.0$ sec.

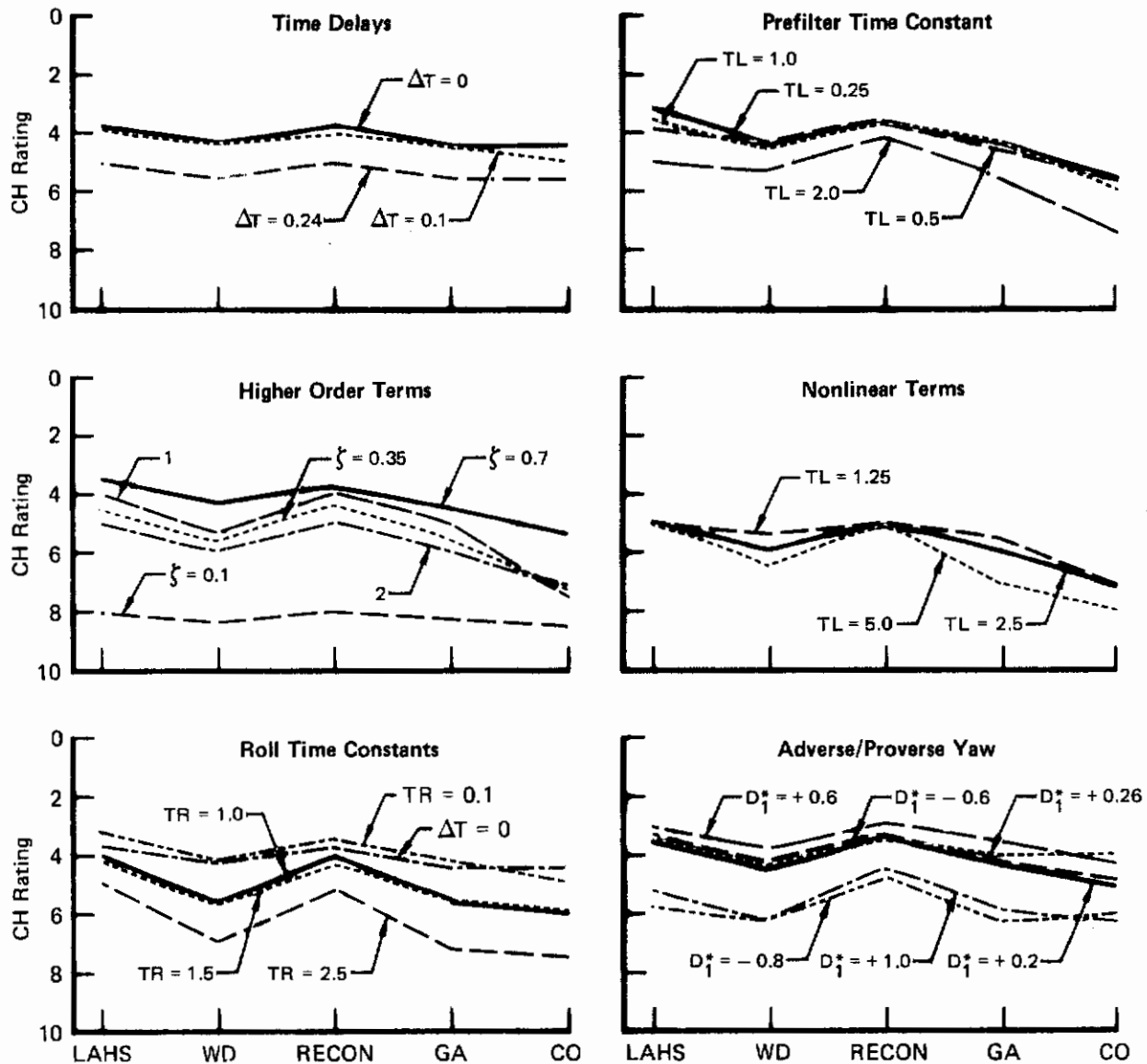

FIGURE 35
RATING SUMMARY - COOPER-HARPER RATING
vs MISSION MODE FOR PARAMETERS INVESTIGATED

Consequently, the lower boundary, as established during analysis, was moved slightly upward as shown in Figure 38. Excessive sensitivity and responsiveness attributed to lateral responses with time constant values less than $T_R = 0.1$ seconds indicated some lowering of the upper boundary was necessary in order to compensate for the adverse effect. The corresponding change has been incorporated into Figure 38 and the associated rate of change envelope has been modified to constrain potential anomalies which may occur in the roll rate response. A comparison of the recommended roll axis criterion with the candidate boundaries is shown in Figure 39.

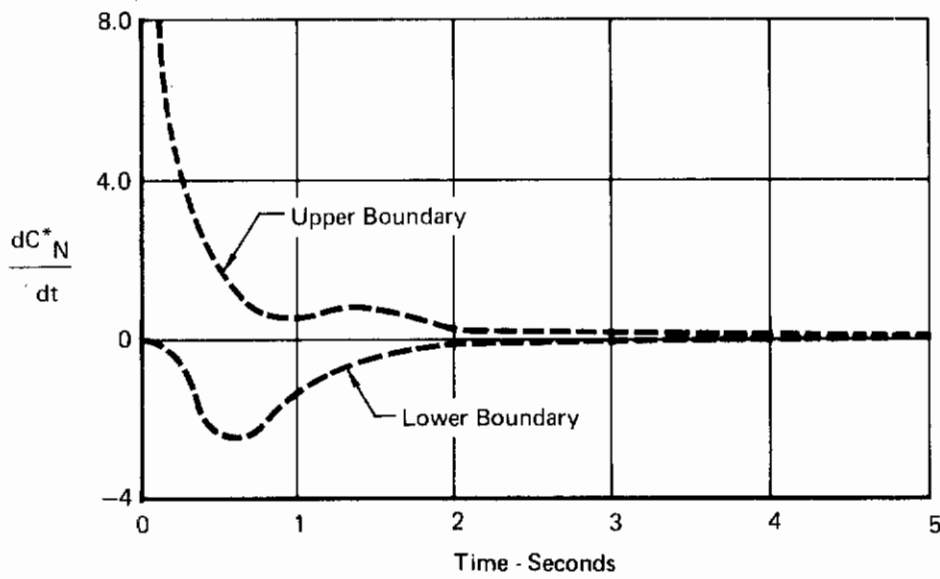
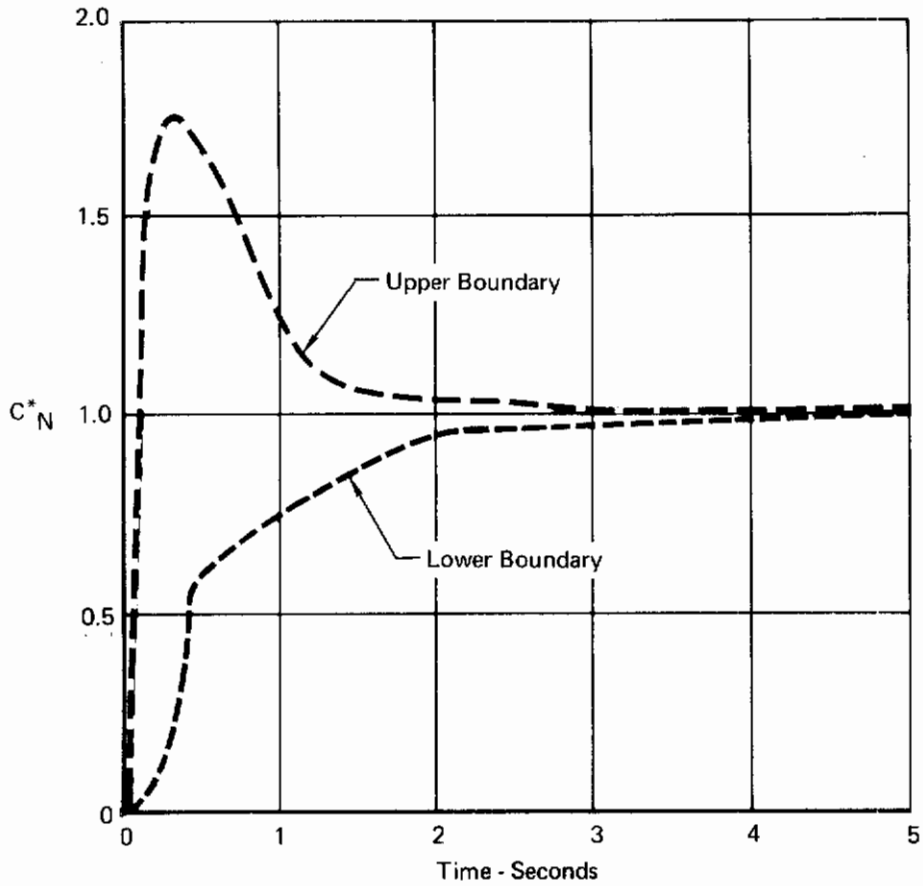

FIGURE 36
SFCS PITCH AXIS TIME HISTORY CRITERION

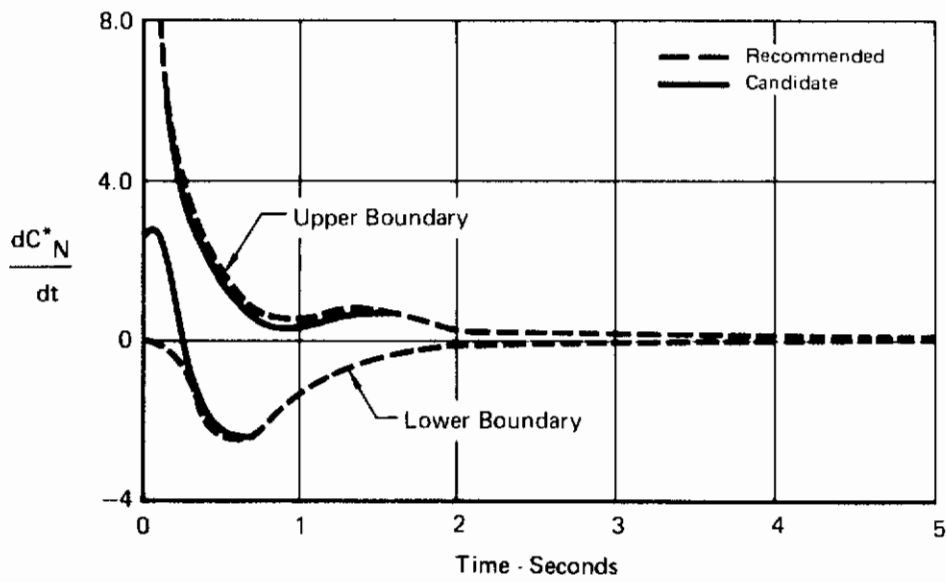
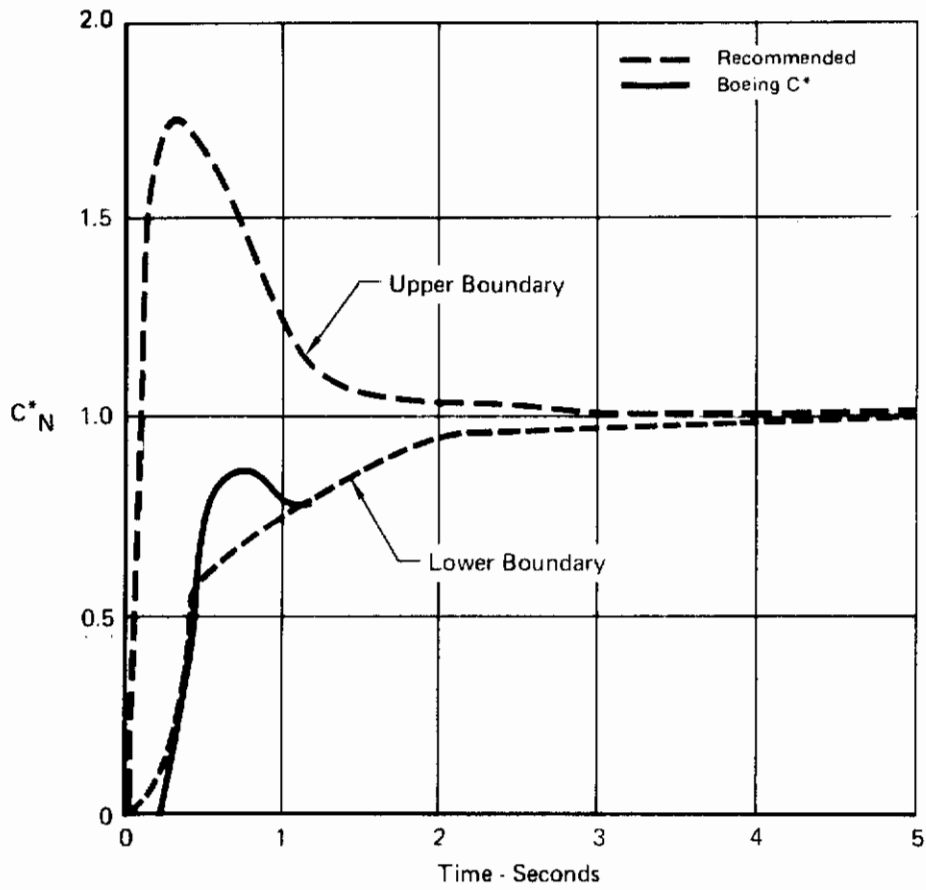

FIGURE 37
SFCS PITCH AXIS TIME HISTORY CRITERION

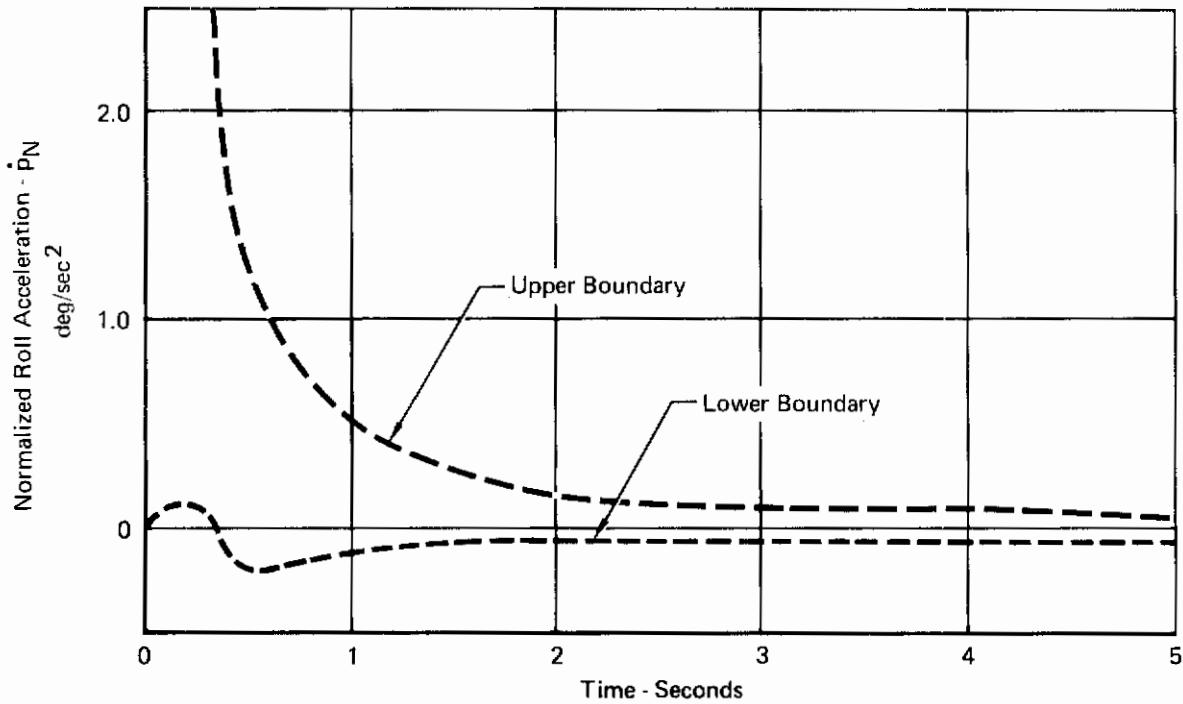
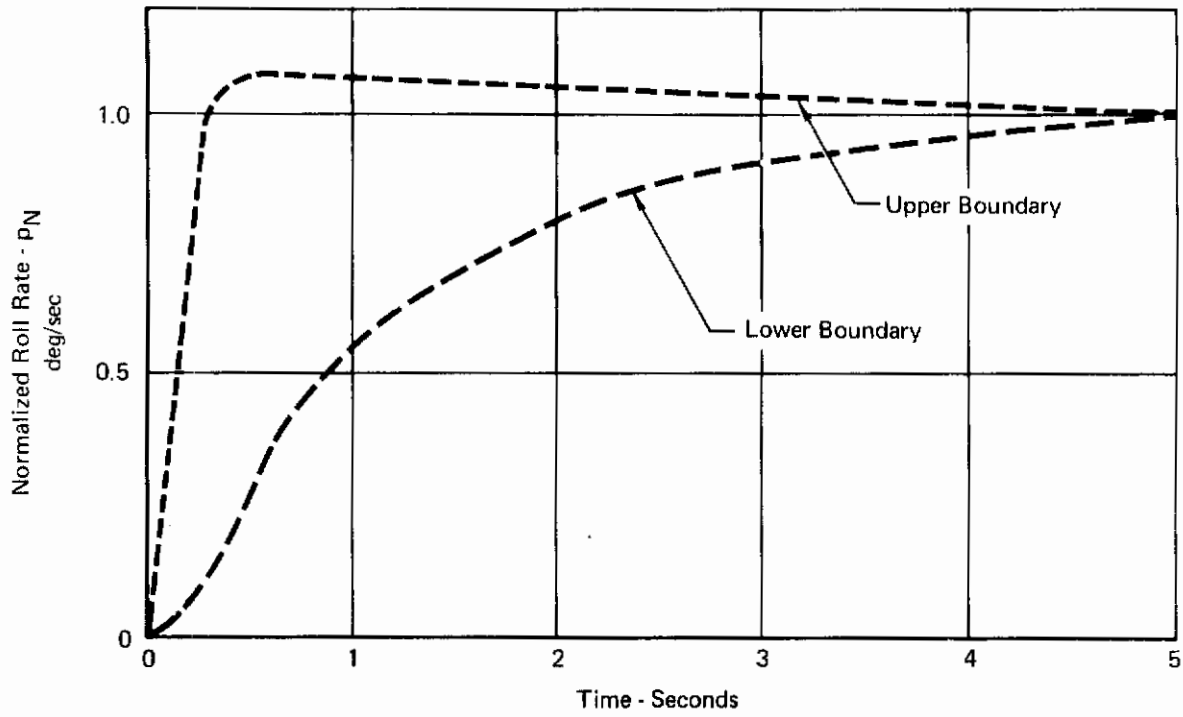

FIGURE 38
SFCS ROLL AXIS TIME HISTORY CRITERION

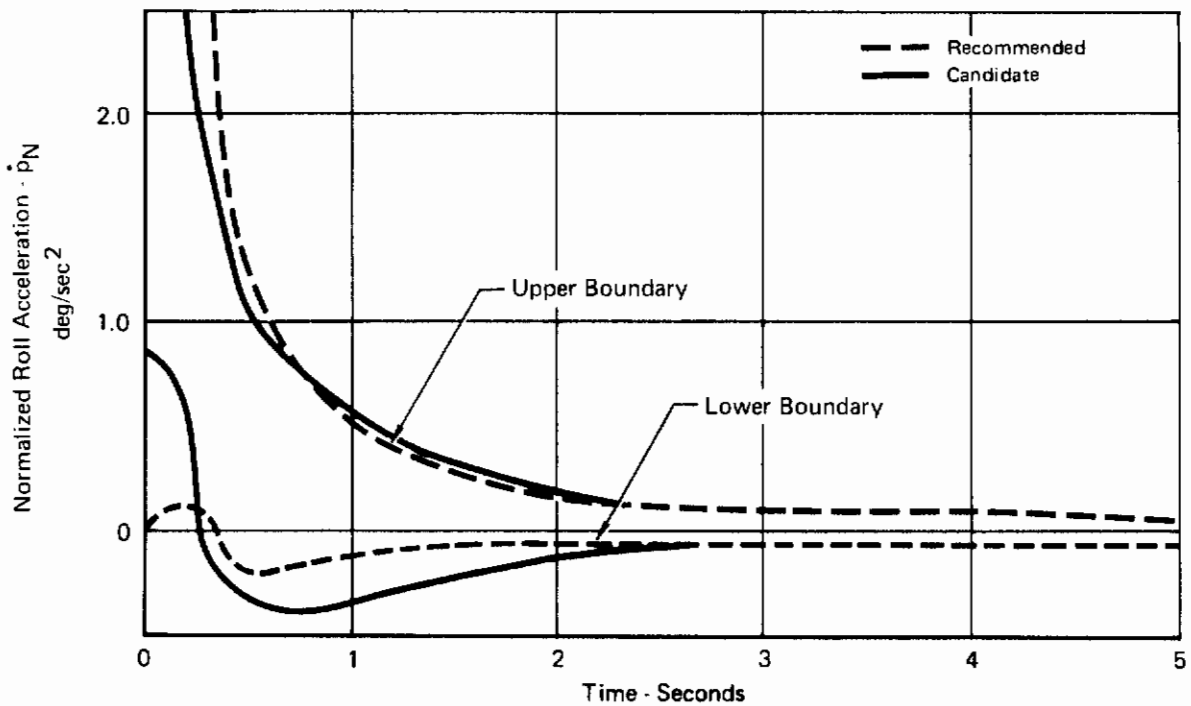
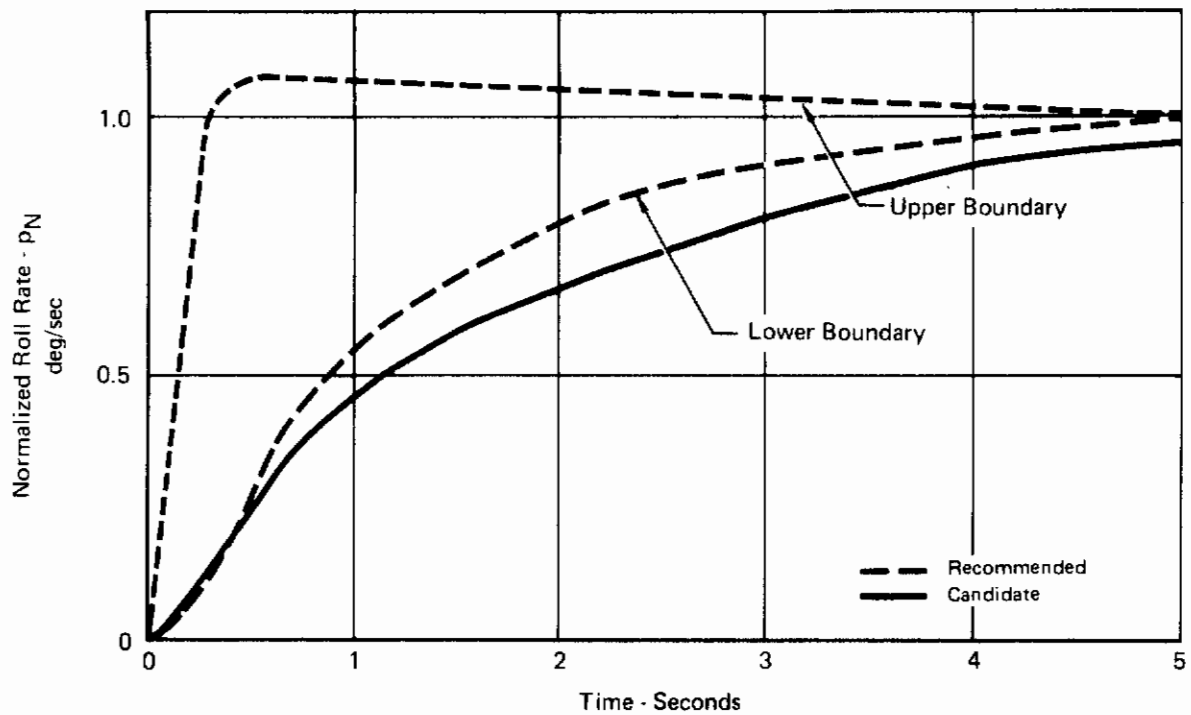

FIGURE 39
SFCS ROLL AXIS TIME HISTORY CRITERION

Contrails

Directional response data and pilot comments obtained during simulated rolling maneuvers indicate that the D^* time history boundary as generated during analysis is representative of the handling quality characteristics desired by the pilots for lateral-directional control. The data presented show that the time history boundary levels as established during analysis are slightly conservative and should be modified upward to the new levels given in Figure 40. These new levels, as shown in the figure, are supported in part by the decoupled configuration data as presented in Section VI. Both D^* and its associated rate of change envelope of acceptability shown in Figure 40 are recommended for use during the evaluation of the SFCS directional control system. A comparison of the recommended criterion with the candidate D^* boundaries is shown in Figure 41.

Since there is no apparent consensus of pilot opinion as to rudder pedal usage during flight and since directional handling qualities for rudder pedal force inputs are not extensively defined in present military specifications, only a cursory investigation of directional response requirements was made. Documentation results indicate that all configurations tested during the study effort provided satisfactory response dynamics with no adverse pilot comments on simulated yaw axis response characteristics. The time history data shown in Figure 24 is representative of the yaw axis speed of response and damping properties inherent in the subject configurations tested during the longitudinal and lateral-directional parameter variations. From these data and the experience gained to date, it is felt that acceptable pilot ratings will be obtained if the D^* time history response to a rudder step force command input has an overshoot of less than thirty percent and is more rapid (faster) than an equivalent single degree of freedom (first order lag) system with approximately unity time constant. These data are the best estimate at this time of the desired directional response characteristics and should be used as a guide in SFCS control law development, until a more comprehensive envelope of acceptability can be established.

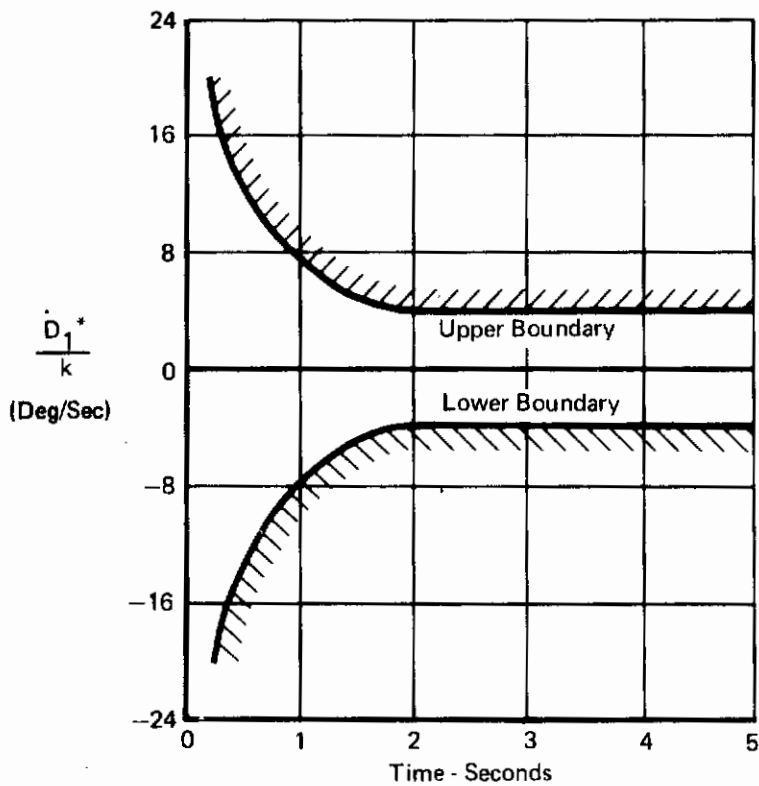
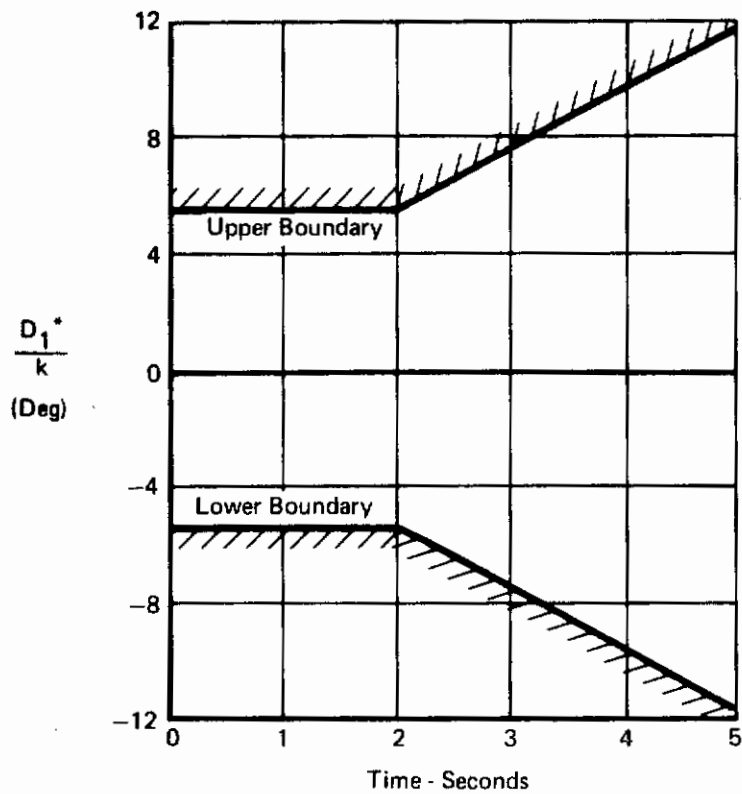

FIGURE 40
SFCS YAW AXIS TIME HISTORY CRITERION

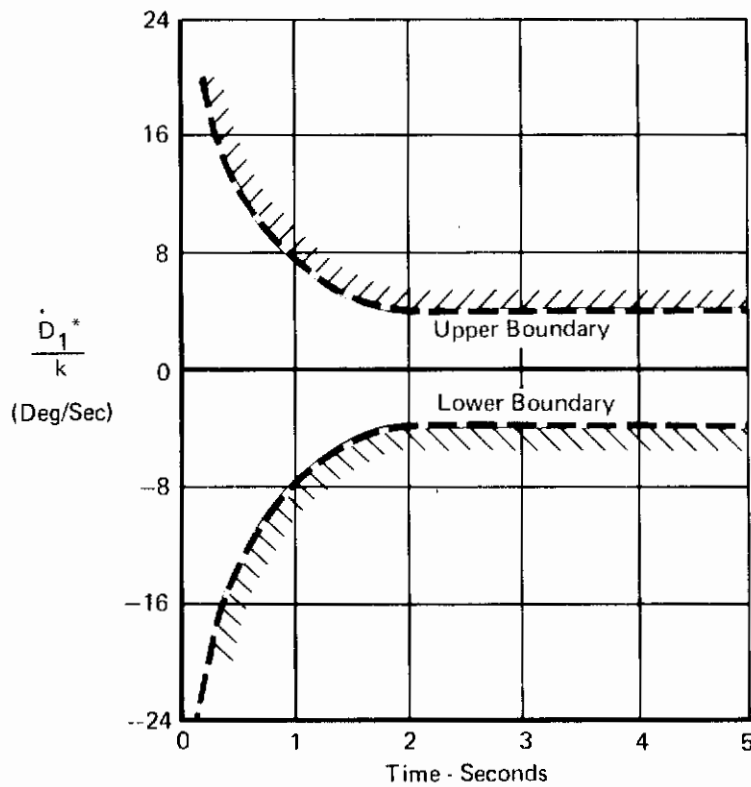
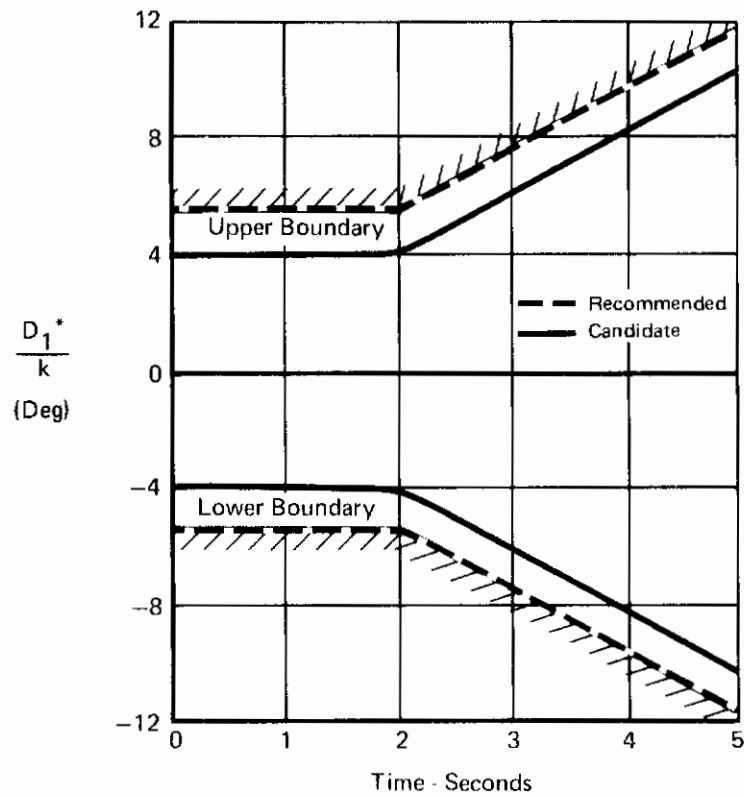

FIGURE 41
SFCS YAW AXIS TIME HISTORY CRITERION

Contrails

SECTION VIII

CONCLUSIONS AND RECOMMENDATIONS

The results of the control performance analyses and simulation studies as presented above support the following conclusions and recommendations reached during the investigations:

1. CONCLUSIONS

- a. The C* concept is applicable for use in the F-4 aircraft SFCS design. Its applicability is based on favorable results obtained from analysis and simulation studies, and on its strong correlation with advanced flight control system designs used successfully in the industry for closed loop augmentation prior to C* concept inception.
- b. From hybrid man-in-the-loop simulation studies and pilot comments, it is concluded that the C* handling qualities are compatible with the F-4 aircraft mission modes investigated. The mission task oriented basing of control laws, and the attendant mode switching, was not found necessary.
- c. Pilots indicated that the optimization of the feel system, as is done with conventional designs, is desirable; however, the high gain, closed loop control of the flight path sufficiently masks the aircraft dynamic response variations to negate the need for precise tailoring of the feel system used with FBW control.
- d. The adverse effect on C* applicability of time history response abnormalities including higher order and nonlinear characteristics can be reduced with modification of lower C* boundary and additional use of C* rate of change envelope of acceptability.
- e. The D* concept, in which lateral acceleration and sideslip angle were combined and used as a lateral-directional counterpart to the C* criterion, was formulated. Preliminary D* criterion boundaries were established for roll command step inputs.
- f. A roll axis time history envelope of acceptability was formulated for lateral step command inputs.
- g. Complete interaxis decoupling, as investigated during the hybrid simulation, did not show significant performance improvement over designs in which maximum ARI effectiveness was realized. Pilot comments indicate preference for zero roll-to-yaw coupling. Non-zero yaw-to-roll is desired and used during low roll effectiveness flight conditions for achieving maximum roll rate. Pilots also desire some yaw-to-roll coupling for high angle-of-attack rolling maneuvers.
- h. Tracking stability and weapon delivery equations were derived, and flight path control performance requirements were investigated. It was found that aircraft gun angle and flight control system dynamics significantly affect pilot-oriented closed loop stability and control. Performance requirements established during the study included the three axes criteria presented above.

Contrails

2. RECOMMENDATIONS

Flight test verification of the candidate criteria described in this report is necessary in order to establish their validity and encourage their usage in future flight control system design efforts.

APPENDIX I

LITERATURE SEARCH

1. INTRODUCTION

A library search of technical publications on Control Performance and Handling Qualities Criteria for high performance aircraft has resulted in the compilation of the list of articles, as shown in Table X of this Appendix. All articles were reviewed for content application to SFCS and grouped into one of the following three categories:

Category A = C* Criteria Articles

Category B = Handling Quality/Simulation Test Plan Articles

Category C = Handling Quality Criteria Articles, General

2. SUMMARY OF APPLICABLE ARTICLES

A brief description of a selected number of articles is included in this report. This review effort was conducted to help formulate an efficient simulation plan and to help insure that anticipated SFCS Control Performance Criteria investigation has not been duplicated during previously reported work.

a. USAF (FDL) TDR-64-60

Flight Evaluation of Various Short Period Dynamics at Four Drag Configuration for the Landing Approach Task (1964) by C.R. Chalk

In the investigation described in this report, the AFFDL/CAL Variable Stability T-33 aircraft was used to study the effect of short period dynamic and drag characteristics on longitudinal handling qualities for the landing approach task. The purpose of the study was to determine if sufficient improvements in handling qualities can be achieved to warrant some reduction in approach and touchdown speed. The piloting task was to fly a constant speed approach which consisted of a straight-in IFR portion followed by transition to a visual glide path defined by an arrangement of lights. The approach was terminated by a wave off and followed by a visual circuit of the field and a second visual approach on the glide path with the same configuration. The pilot then commented on the control difficulties that he had experienced, answered a list of specific questions and finally assigned a pilot rating to the configuration. The airplane was equipped with electro-hydraulic servos to position the elevator, rudder, aileron, and drag surfaces in response to combinations of pilot commands and airplane response parameters. Airplane angle of attack, angle of sideslip, angular rates, linear and angular accelerations, dynamic pressure and random noise generator were available as sensor feedback inputs to the servos. Cockpit mechanization also allowed independent variation of the control system characteristics during flight. Lateral directional mechanization included yaw rate

(Text continues on Page 102)

TABLE X - CONTROL PERFORMANCE CRITERIA REFERENCES

<u>Identification</u> (Lib. No.)	<u>Author</u>	<u>Title</u>	A	B	C	<u>Category</u>
(1) NACA RM L56F12a	Adams	Flight and Analytical Study of Roll Requirements of a Fighter Airplane (1956)			X	X
(2) AIAA Paper 63229	R.C.A'Harrach (NAA)	An Investigation of Low-Altitude, High Speed Flying and Riding Qualities (1963)		X		X
(3) NATO(AGARD)Rpt. 443	A'Harrach(NAA)	Low Altitude, High Speed Handling and Riding Qualities (1963)		X		X
(4) NAA INC.(COLUMBUS DIV)Rpt.NA62H-397	A'Harrach (NAA)	An Investigation of Low Altitude, High Speed Flying and Riding Qualities of Aircraft (1963)		X		X
(5) NATO(AGARD)Rpt. 556	A'Harrach (NAA)	Maneuverability and Gust Response Problems Associated with Low Altitude, High Speed Flight (1967)				X
(6) NACA RM A54I28	Amoramovitz	The Effect of Stick-Force Gradient and Stick Gearing on the Tracking Accuracy of a Fighter Airplane (1954)				X
(7) MAC Rpt. B528	Anderson (MAC)	Model F-4 Longitudinal Flying Qualities (1966)				X
(8) AIAA Paper 65-314	Ashkenas(STI)	A Consolidation of Lateral-Directional Handling Qualities (1965)				X

TABLE X - CONTROL PERFORMANCE CRITERIA REFERENCES (Continued)

<u>Identification</u>	<u>Author</u>	<u>Title</u>	A	B	C
(9) USAF (FDL)TR-65-138	Ashkenas (STI)	A Study of Conventional Airplane Handling Qualities Requirements Pt. I - Roll Handling Qualities Pt. II - Lateral-Directional Oscillatory Handling Qualities (1965)			X
(10) NATO (AGARD) Rpt. 533	Ashkenas (STI)	Some Open and Closed Loop Aspects of Airplane Lateral-Directional Handling Qualities (1966)			X
(11) USAF (FDL)TR-65-198	W. Bihrl	A Handling Qualities Theory for Precise Flight Path Control (1966)			X
(12) SAE Paper 171B	Bull	Minimum Flyable Handling Qualities of Airplanes (1960)			X
(13) MAC Rpt. 6279	Casper (MAC)	F3H-2N Flight Test Summary of Model Determined Longitudinal Flying Qualities (1958)			X
(14) USAF (ASD)TDR-63-399	R.C. Chalk (CAL)	Fixed Base Simulator investigation of the Effects of I_q and True Speed on Pilot Opinion of Longitudinal Flying Qualities (1963)		X	
(15) USAF (FDL)TDR-64-60	R.C. Chalk (CAL)	Flight Evaluation of Various Short Period Dynamics at Four Drag Configuration for the Landing Approach Task (1964)			X
(16) USAF (FDL)TR-66-2	R.C. Chalk (CAL)	Flight Evaluation of Various Phugoid and l/Thi Values for the Landing Approach Task (1966)			X

TABLE X - CONTROL PERFORMANCE CRITERIA REFERENCES (Continued)

<u>Identification</u>	<u>Author</u>	<u>Title</u>	<u>Category</u>		
			A	B	C
(17) CAL. INC. FDM-397	Chalk (CAL)	Some Observations Concerning Lateral Directional (1966)			X
(18) AIAA Paper 68-245	Chalk (CAL)	Airplane Flying Qualities Specification Revision (1968)			X
(19) NASA TN D-5153	Cooper (NASA)	The Use of Pilot Rating in the Evaluation of Aircraft Handling Qualities (1969)		X	
(20) Sys. TECH. INC. TRI 24-1	Cromwell (STI)	A Systems Analysis of Longitudinal Piloted Control in Carrier Approach (1962)			X
(21) AIAA Paper 65-794	Cromwell (USN-WEPS)	Flying Qualities Requirements as Related to Control System Complexity (1965)			X
(22) IAS Paper 60-18	Crone	Development of Lateral-Directional Flying Qualities Criteria for Supersonic Vehicles, Based on a Stationary Flight Simulation Study (1960)		X	
(23) USAF (FDL) TR-67-135	Difranco (CAL)	An In-Flight Simulation of Handling Qualities of the SV-5P (Pilot) Lifting Body With Various Feedback Gains and Rudder to Aileron Interconnect Ratios (1967)			X

TABLE X - CONTROL PERFORMANCE CRITERIA REFERENCES (Continued)

Identification	Author	Title	Category		
			A	B	C
(24) USAF(FDL)TR-66-163	Difranco(CAL)	Flight Investigation of Longitudinal Short Period Frequency Requirements and PIO Tendencies (1967)			X
(25) USAF(FDL)TR-68-90	Difranco(CAL)	In Flight Investigation of the Effect of Higher Order Control System Dynamics on Longitudinal Handling Qualities(1968)			X
(26) MAC EN-217	Doerr(MAC)	Model F101 "Hot Rod" Estimated High Speed Flying Qualities of Proposed M-2.00 Prototype(1959)	X		X
(27) USAF(FDL)TR 65-218	D. Drake (DAC)	Estimation of Flying Qualities of Piloted Airplanes (1966)	X		X
(28) ASD-TDR-62-507	Durand/Jex (STI)	Handling Qualities in Single-Loop Roll Tracking Tasks: Theory and Simulator Experiment (1962)	X		X
(29) Princeton U. (A & MS) Rpt. 777	Eney (Princeton U.)	Comparative Flight Evaluation of Longitudinal Handling Qualities in Carrier Approach (1966)		X	X
(30) AIAA Paper 67-576	Eney(USN)	Navy Variable Stability Studies of Longitudinal Handling Qualities(1967)			X
(31) ICAS Paper 68-17	Gedeon (Hungarian)	A Statistical Treatment of Pilot-Opinions on Flying Qualities(1968)			X

TABLE X - CONTROL PERFORMANCE CRITERIA REFERENCES (Continued)

<u>Identification</u>	<u>Author</u>	<u>Title</u>	<u>Category</u>	
			A	B
(32) NACA RM L53C27	Hamer	Time History Data of Maneuvers Performed by a Republic Airplane During Squadron Operational Training (1953)		X
(33) NACA RM L53B27	Huss	Time History Data of Maneuvers Performed by a Lockheed-F94B Airplane During Squadron Operational Training		X
(34) IEEE(NAECON) Proc. 196 (Ses . IV)	IEEE	Session IV-Advancements in Adaptive Flight Control (1966)		X
(35) ASD-TR-61-26	H.R.Jex (STI)	Theoretical and Experimental Investigation of Some New Longitudinal Handling Qualities Parameters (1961)		X
(36) Systems Tech. Inc. TR136-1	H.R.Jex	Feasibility Study for an F106B Variable Stability Trainer(1963)	X	
(37) NATO(AGARD) Rpt.368	Kidd	In Flight Simulation-Theory and Application (1961)	X	
(38) USAF(ASD)TDR-61-362	E.Kidd(CAL)	Fixed Base and In-Flight Simulations of Longitudinal and Lateral Directional Handling Qualities for Piloted Reentry Vehicles (1964)	X	
(39) LTV/AERO Rpt.2-59110/5R-5164	Klink	Pre-Evaluation Engineering Data Report for Model A-7A Airplane (1965)		X

TABLE X - CONTROL PERFORMANCE CRITERIA REFERENCES (Continued)

<u>Identification</u>	<u>Author</u>	<u>Title</u>	A	B	C
(40) AGARD Rpt. 336	Koven/Wasicko	Flying Quality Requirement for U.S. Navy and Air Force Aircraft (1961)			X
(41) NACA RM L53F08a	Kuehnel	A Flight Investigation of the Effect of Varied Lateral Damping on the Effectiveness of a Fighter Airplane as a Gun Platform (1953)			X
(42) USN(NATC)FT-13R-69	Lantzer	Navy Flying Qualities Evaluation of the F-4J Airplane as Modified for Use by the Blue Angels (1969)			X
(43) NACA CON 51L03-4 Pt.18	Lindell	Relation of Pilots Impression and Gunnery Errors to the Lateral Oscillator Characteristics			X
(44) AIAA Paper 68-189	Larrabee (MIT)	The Effect of Flying Qualities Requirements on the Design of General Aviation Aircraft in the 1980's (1968)			X
(45) British(ARC)C.P.833	Leyman (Bristol A/C)	A Survey of Aircraft Handling Criteria (1964)			X
(46) Boeing Co.(AD) Doc.D6-17841 T/N	Malcom (Boeing)	New Short Period Handling Quality Criteria for Fighter Aircraft (1965)		X	
(47) NACA RM A53B11	Matthews	A Theoretical Study of the Effect of Control-Deflection and Control-Rate Limitations on the Normal Acceleration and Roll Response of a Supersonic Interceptor (1953)			X

TABLE X - CONTROL PERFORMANCE CRITERIA REFERENCES (Continued)

<u>Identification</u>	<u>Author</u>	<u>Title</u>	<u>Category</u>		
			A	B	C
(48) USN(WADC)-ED-6282	Mazza	Proposal for a Revised Military Specification "Flying Qualities of Piloted Aircraft" (MIL-F-8785 ASG), With Substantiating Text (1963)			X
(49) USAF(FDL)TR-68-76	McDonnell (STI)	Pilot Rating Techniques for the Estimation and Evaluation of Handling Qualities (1968)			X
(50) NACA RM A51C28	McNeill/ Cooper	A Comparison of the Measurand and Predicted Lateral Oscillatory Characteristics of a 35° Swept Wing Fighter Airplane (1951)			X
(51) NACA RM A53H10	McNeill/ Cooper	A Flight Study of the Effects on Tracking Performance of Changes in the Lateral Oscillatory Characteristics of a Fighter Airplane (1953)			X
(52) USAF-WADD-TR-68-43	McRuer/ Ashkenas (STI)	A Systems Analysis View of Longitudinal Flying Qualities (1960)			X
(53) USAF(FDL)TR-67-98	Meeker (CAL)	In-Flight Evaluation of Lateral-Directional Handling Qualities for the Fighter Mission (1967)			X
(54) USN(NATC)FT-2123-34R-65	Miller	Flight Simulator Evaluation of the F-111B Predicted Flying Qualities in the Power Approach Configuration 1st Interim Rpt. (1965)			X

TABLE X - CONTROL PERFORMANCE CRITERIA REFERENCES (Continued)

<u>Identification</u>	<u>Author</u>	<u>Title</u>	<u>Category</u>		
			A	B	C
(55) AIAA Paper 67-577	Miller (Princeton U.)	Lateral-Directional Flying Qualities for Power Approach(1967)		X	
(56) USAF(FTC)TR-65-6	Mitchell	F-5A Category II Stability and Control Tests (1965)			X
(57) USN(NAVTRADEVCEEN)	F.D.Newell (CAL)	Criteria for Acceptable Representation of Airplane Dynamic Responses in Simulators Used for Pilot Training (1962)		X	
(58) USAF(FDL)TR-65-39	Newell(CAL)	Ground Simulator Evaluations of Coupled Roll-Spiral Mode Effects on Aircraft Handling Qualities (1965)		X	
(59) USAF(FDL)TR-67-30	Newell(CAL)	Human Transfer Characteristics in Flight and Ground Simulation for the Roll Tracking Task (1968)		X	
(60) MAC Rpt. E583	Niemann (MAC)	Model F-4 Lateral-Directional Flying Qualities			X
(61) MAC Rpt. E583 Addendum II	Niemann (MAC)	Model F-4 Lateral-Directional Flying Qualities F-4J Addendum (1967)			X
(62) AIAA Paper 64-555	O'Hara (British)	Prediction of Aircraft Flying Qualities by Flight Simulators and Other Methods With Flight Comparisons (1964)		X	

TABLE X - CONTROL PERFORMANCE CRITERIA REFERENCES (Continued)

<u>Identification</u>	<u>Author</u>	<u>Title</u>	<u>Category</u>	
			A	B
(63) USAF(FDL)TR-67-19	Parrag(CAL)	Pilot Evaluation in a Ground Simulator of the Effects of Elevator Control System Dynamics in Fighter Aircraft (1967)		X
(64) British(RAE) TM Aero-952	Perry	Flight Simulation-Some Aspects of its Use for Studies of Aircraft Handling Qualities(1966)	X	
(65) British(RAE)TR 66138	Perry	A Piloted Flight Simulator Study of Speed Instability During the Landing Approach	X	
(66) NACA RM A53H12	Rathert	An Analysis of the Tracking Performance of Two Straight-Wing and Two Swept-Wing Fighter Airplanes with Fixed Sights in a Standardized Test Maneuver (1953)		X
(67) NAA INC(Columbus) Rpt. PG 59710	Richardson (NAA)	The Application of Flight Simulators to the Development of the A-5A Vigilante (1963)		X
(68) USAF(FTC)TR-68-1	Rutan	A-7A Limited Handling Qualities Evaluation (1968)		X
(69) NASA TN D-2793	M.D.Sadoff (NASA)	Pilot-Vehicle System Simulation for Low Altitude, High-Speed Flight (1965)	X	
(70) British ARC CP 837	Saunders	Handling Qualities of Aircraft With Marginal Longitudinal Stability (1964)	X	

TABLE X - CONTROL PERFORMANCE CRITERIA REFERENCES (Continued)

<u>Identification</u>	<u>Author</u>	<u>Title</u>	A	B	C
(71)	Princeton(U)Rpt.727 Seckel (Princeton U.)	Lateral-Directional Flying Qualities for Power Approach(1966)			X
(72)	Princeton U. (A & MS)Rpt. 707 Seckel (Princeton U.)	Lateral-Directional Flying Qualities for Power Approach Influence of Dutch Roll Frequency (1967)			X
(73)	LTV.AERO CORP. Rpt. 2-53320/8R-8089 Seth (LTV)	A-7D Estimated Flying Qualities (1968)			X
(74)	NASA TM X-1583 Sisk	A Preliminary Flying Qualities Evaluation of a Variable-Sweep Fighter-Type Aircraft (1968)		X	
(75)	USAF(FDL)TR-65-97 Smith	In-Flight Evaluation of Certain Lateral-Directional Handling Qualities of High-Performance Aircraft (1965)			X
(76)	USAF(FDL)TR-67-2 Stapleford (STI)	Analysis of Several Handling Quality Topics Pertinent to Advanced Manned Aircraft (1967)			X
(77)	AIAA Paper 67-S79 Stapleford (STI)	Effects of Manual Attitude Control and Other Factors on Short-Period Handling Quality Requirements(1967)			X
(78)	NASA(FRC)Paper 66E11 Taylor(NASA)	Recent Research Directed Toward the Prediction of Lateral-Directional Handling Qualities (1966)		X	

TABLE X - CONTROL PERFORMANCE CRITERIA REFERENCES (Continued)

<u>Identification</u>	<u>Author</u>	<u>Title</u>	<u>Category</u>	
			A	B
(79) NATO(AGARD)Rpt. 531	Taylor(NASA)	Recent Research Directed Toward the Prediction of Lateral-Directional Handling Qualities (1966)		X
(80) USAF(FDL)TR-66-148	USAF	Flying Qualities Conference-Wright-Patterson A/F Base, Ohio (1966)		X
(81) NASA TN D-4410	Van Leynseele (NASA)	Evaluation of Lateral-Directional Handling Qualities of Piloted Reentry Vehicles Utilizing a Fixed Base Simulation (1968)	X	
(82) MAC Rpt. B583 Addendum I	Weber (MAC)	Model F-4 Lateral-Directional Flying Qualities F-4K/M (1966)		X
(83) AIAA Paper 65-313	Westbrook (USAF)	The Status and Future of Flying Qualities Requirements (1965)		X
(84) USAF(FDL)FDCC TM 66-5	Westbrook	Handling Qualities and Pilot Work Load (1966)		X
(85) NASA TM X-715	White	Resume of Handling Qualities of the X-15 Airplane (1962)		X
(86) NACA RM L52A08	Williams	Handling Qualities of High Speed Airplanes (1952)		X
(87) USAF(FDL)TR-67-49 Vol. I	Wykes(NAA)	A Gust Alleviation and Structural Dynamic Stability Augmentation System Design for Low Altitude High Speed Flexible Aircraft(1965)		X

TABLE X - CONTROL PERFORMANCE CRITERIA REFERENCES (Concluded)

<u>Identification</u>	<u>Author</u>	<u>Title</u>	<u>Category</u>	
			A	B
(88) USAF(FDL)TR-68-10 Pt.II	Yore	Application of Mark III-SOC(Self-Organic Control) To Multivariable Control Problems-Pt.II-Optimal Decoupling Control Applied to Lateral-Directional Axes of a Sweep Wing Aircraft (1968)		C
(89) USAF(ASD)Rpt.62D02	-	USAF Handling Quality Research-Summary of Current Contracted Programs (1962)		X

Contrails

feedback (not washed out) to improve Dutch Roll damping and to avoid excessive response to atmospheric turbulence. Longitudinal short period dynamics were varied through the use of feedback signals proportional to angle of attack, rate of angle of attack, and pitch rate. The drag characteristics were varied through the airplane configuration (i.e., landing gear up or down, flaps up or down), the nominal position of the drag petals and the gain between the petals and the angle of attack vane.

Conclusions reached from the study include:

- (1) The airplane short period dynamics and longitudinal control gain are of major importance to longitudinal handling qualities in the landing approach task.
 - (a) When the damping ratio is decreased below $\zeta_{sp} \doteq .4$ the airplane will bobble in response to both control inputs and turbulence.
 - (b) When the short-period frequency is less than $\omega_{sp} \doteq 1.6$ rad/sec the airplane does not readily maintain^{sp} angle of attack or attitude by itself.
 - (c) The optimum longitudinal control gain is a function of the short period frequency and damping ratio.
 - (d) Too high a control gain can cause closed-loop stability problems or pilot-induced oscillations, while too low a control gain results in excessive control motion and the feeling that the control authority is inadequate and/or the airplane response is sluggish.
 - (e) The power spectral density of elevator stick motion is a function of short period dynamics and turbulence intensity.
- (2) Control of airspeed and flight path angle becomes progressively more difficult as approaches are made at increasing negative slope of the trimmed thrustspeed curve; or more exactly, as the value of $s = 1/T_{h_1}$, moves farther into the right-half plane.
 - (a) Control of airspeed and altitude on the glide slope is achieved through coordinated use of pitch attitude and engine thrust.
 - (b) Short period dynamic characteristics which reduce the precision of pitch attitude control will consequently degrade the precision of flight path and velocity control.

- b. NATO (AGARD) Report 336
Flying Quality Requirements for United States Navy and Air Force Aircraft (1961) by W. Koven and R. Wasicko

The report describes the major features of the US military aircraft flying quality requirements, reviews the history of the requirements, and outlines the reasons for some of the current flying qualities specifications. The report shows that there are inadequacies in the specifications of flying qualities and presents some alternate approaches for establishment of future flying quality requirements.

The report states that the military flying qualities specifications are based in part on compromises between the desires of the pilot and the design requirements for adequate payload, speed, altitude capability, maneuverability, range, production costs, and maintainability. The reasons for some of the main flying quality requirements are presented. The friction, free play, and rate limiting in airplane controls are important to the pilot because they affect his ability to establish and maintain a precise flight path and attitude. Adequate damping in the short period mode is required since excessive sustained oscillations may lead to vertigo and loss of control. At low speeds adequate roll control is required so that the wings can be maintained level during landing in turbulent air.

The report also mentions requirements where the original specification, MIL-F-8785, is inadequate. Since the report issue, in April 1961, some of the inadequacies mentioned in the report have been corrected in the revised specification, MIL-F-008785A(USAF). One of the corrected items is the requirement that the phugoid mode time to double amplitude, T_2 , exceeds 55 seconds. Another corrected item is the requirement for a limit on the minimum natural frequency of the Dutch Roll (approximately 0.15 cycles per second).

A number of past studies are mentioned where apparent discrepancies have been noted in the data used as a basis for flying quality requirements. It is concluded that the apparent discrepancies in the data are probably due to the differences in the test conditions, such as flight environment, pilot opinion rating scales, and the like. Therefore, the writers of the report consider it mandatory that the user of flying quality requirements understands the background of the requirements and is familiar with the data which were used in deriving the requirements.

The report concludes that the pilot opinion of the dynamic characteristics of an airplane is not determined by any one parameter, but instead is determined by the overall complete dynamics of the system the pilot is controlling (displays, cockpit controls, automatic control systems, and airframe). It is concluded that the flying quality requirements should be specified in terms of the overall dynamic characteristics of the system, that is, the systems approach should be used. The report also states that additional research is needed to provide a better understanding of pilot's response characteristics.

- c. NATO (AGARD) Report 443
Low-Altitude, High-Speed Handling and Riding Qualities (1963)
by Ralph C. A'Harrah

This reference presents the results of flight tests and simulator studies of handling and riding qualities at low altitudes and high speeds. The altitude range of interest was from zero to 500 feet above the terrain and the results of the study are applicable for speed range from 0.6 Mach to 1.2 Mach.

The flight test portion of the investigation was performed in an F9F-8T airplane. The test pilot was sitting in the rear cockpit and his portion of the canopy was frosted. His assigned task was to follow the terrain under "Instrument Flight Rules" conditions. An artificial terrain signal was generated by a mechanical cam arrangement and the actual altitude at which the flights were performed is not stated in the report. The same terrain was used in flight testing as in the simulator portion of the program. In flight testing and in simulation runs the altitude error was displayed to the pilot on a cathode ray tube. In addition, an instantaneous rate of climb indicator was displayed to the pilots to aid them in providing lead compensation. The actual test flights were performed at speeds of 0.6 and 0.7 Mach and the range of speeds was then extended on the simulator to cover the interval from 0.6 Mach to 1.2 Mach.

The results of the flight test portion of the program were used primarily to establish validity of the ground based dynamic simulation setup. The bulk of the study results were obtained in the simulator runs. The simulation was primarily concerned with pitch and altitude motion; the third degree of freedom, roll attitude, was simulated only in a few runs when the effect of task sharing was investigated. The dynamic flight simulator included a one-degree-of-freedom vertically moving cockpit ("G" seat) with a total travel of approximately 12 feet and acceleration capability of $\pm 6g$. The simulation cockpit contained the display instrumentation and a functional control system with simulated stick forces.

One of the first tasks performed on the simulator were the check runs which were made to establish validity of the simulation. To establish simulation validity an attempt was made to accurately duplicate five test flights on the simulator. Records of atmospheric turbulence were obtained during each of the five flights and this recorded gust-induced load factor signal was then used to drive the simulator during the validation runs. After five validation flights the pilots felt that the authenticity of the simulation had been proven and that further validation flights are not required. The data obtained on the simulator were generally similar to the data obtained in test flights. However, the mean altitude above terrain was approximately 110 feet higher for the test flights than for the simulator flights, and it appears that in simulator flights the pilots were more willing to accept negative load factors.

Contrails

In evaluation of handling qualities the pilots were asked to rate the basic airplane stability independently of the control system rating; still the author states that any such closed loop evaluation is bound to show some "inter-effect". The results defining satisfactory airplane stability characteristics are presented as an acceptable region in a frequency versus damping plot for the short period mode. The acceptable short period frequencies range approximately from 0.4 cps to as high as 3.0 cps, and the corresponding range of acceptable damping ratio values is approximately between 0.2 and 1.5. The author compares his results with an earlier Cornell Aeronautical Laboratory reference (WADC TR 57-719, Part II, by C. R. Chalk) and notes that the acceptance region for short period frequencies up to 1.0 cps is approximately the same in both studies. However, the earlier Cornell study shows an unacceptable region at frequencies above 1.2 or 1.5 cps, while this report indicates an acceptable region extending to frequencies as high as 3.0 cps.

In describing the results of the control system investigation the report concludes that the choice of the control stick force gradient and stick sensitivity should depend on whether or not a particular aircraft has PIO (pilot induced oscillations) tendencies. In general, suitable force gradients fall between 1.0 and 10.0 lb/g and suitable sensitivities are somewhere between 1.0 and 10.0 g/inch.

The Cooper Rating Scale was utilized and, in order to provide an index of dispersion for the ratings, the standard deviation values were computed. The standard deviation values for the ratings were found to range between 0.26 and 0.97, which is considered acceptable.

- d. AIAA Paper 64-555
Prediction of Aircraft Flying Qualities by Flight Simulators and Other Methods With Flight Comparisons (1964) by F. O'Hara

In this paper, a brief account is given of some work in connection with the prediction of flying qualities, the study of flight dynamics by free flight models, and the development of ground based flight simulator techniques.

Flying qualities of our aircraft are evaluated from handling criteria. The aircraft is considered to have good handling characteristics if desired states of flight can be maintained or maneuvers completed with little mental or physical effort, and conversely the aircraft has bad handling characteristics if large effort is required to perform these tasks. Whatever analytical methods are proposed for the assessment of the aircraft flight dynamics, their reliability depends on the accuracy with which the characteristics, aerodynamic, inertia, etc. can be predicted. During the design stages of an aircraft, existing handling criteria have to be used for guidance as to the probable qualities of the project, and in some cases design modification may be required because of indications of unsatisfactory handling characteristics.

Contrails

The study of the motion of free flight models has the attraction of providing direct evidence of an aircraft's dynamic characteristics without the need for analytical formulation of aerodynamic data, which are required for the solution of the theoretical equations of motion. Techniques employing models which are both geometrically and dynamically similar to an aircraft can be used to study stability and response over a wide range of flight conditions. The free flight model may be the only practicable method of investigation when the aerodynamic derivatives are markedly nonlinear and frequency dependent, or where cross coupling terms are important. The free flight models have been used to investigate the following: spinning characteristics of fighter aircraft, measure stability derivatives and to explore onset of Dutch Roll instability, derivatives m_z and m_q have been determined from longitudinal tests.

The advantages of flight simulators for making handling assessment are that more of extra elements in the flight situation can be included in the assessment, and most important, that the pilot himself is enabled to experience the proposed stability and control characteristics, and possibly try out variations on these, at an early stage in a new design. The main factors which have to be considered in making a simulator investigation are: Computation of aircraft motion, presentation of simulation to pilot and pilot impressions.

In conclusion it can be said that the various methods of predicting handling qualities can be seen to be complementary. Comparison of estimated flying characteristics with existing criteria is the first guide for a new project. For unconventional designs, the relevance of available handling criteria is uncertain, and a flight simulator then offers the simplest way to a handling assessment, the validity of which depends on the representativeness of the simulation. The reliability of the results also depends of course on the accuracy of the data used and on the completeness of the mathematical analysis. For more complex motions, and also for an overall check on studies of simple motions, the free flight model technique is invaluable. The final answer is the flying aircraft, and the dependability of all methods can be determined and improved by more detailed comparisons of predicted and flight results.

- e. AIAA Paper 65-313
The Status and Future of Flying Qualities Requirements (1965)
by Charles B. Westbrook

The purpose of this paper is to give perspective to the subject of handling qualities criteria. This paper presents the status of handling qualities criteria as of July, 1965. History and evolution of requirements is traced and the various philosophies of requirements and approaches to handling qualities are discussed.

Contrails

History of the flying requirements is traced from 1907, when U.S. Signal Corps issued Signal Corps Specifications 486, through the latest MIL-F-8785. First set of Air Corps Requirements Specification C-1815 were issued in 1943. MIL-F-8785 was first published in 1954 as an improvement to Specification 1815B, published in 1948. With minor corrections MIL-F-8785 contains the current flying quality requirements for conventional aircraft.

Several of the philosophies as to the proper handling qualities specifications are:

- o Some specifications are contractual instruments listing absolute requirements that must be guaranteed; others have had much design guidance included.
- o Requirements can be looked upon across the whole spectrum from minimum to optimum.
- o Handling qualities specifications can be considered as either a flight test demonstration specification or as a design specification.
- o Quantitative requirements are generally desired by both manufacturer and buyer.
- o Data requirement specifications have at times been used as a partial substitute for inadequate specifications of handling qualities.
- o Difference between FAA requirements and Air Force-Navy requirements is in philosophy, content and implementation.

The traditional approach towards handling qualities criteria has been to collect pilot opinion data on as many vehicles as possible. After obtaining the mass of opinion data either from current aircraft or from variable stability aircraft or ground simulators correlation of these data against various airframe parameters is then attempted, based on judgement or intuition.

The current trends that have import with respect to the present state of affairs are:

- o Economic factors of system development.
- o Current practices of fixed price contracts and speeding up of design have a large impact on handling qualities criteria.
- o Aircraft have become much more complex and there has been great advance in flight control technology.
- o Better analysis procedures and simulation capability has squeezed much redundancy out of designs.

Contrails

Some of the problem areas of the flying qualities requirements are: lateral-directional dynamics, structural modes, stalling, spinning, and pilot induced oscillations. These problems have to be investigated much more in the future.

The following conclusions are made in this paper:

- (1) Aggressive action is needed to improve the entire spectrum of handling qualities criteria.
- (2) The Air Force can and must find a way to quantify "pay off" functions related to handling qualities.
- (3) Some means must be found to achieve a closer interrelationship between the contractor and the Air Force with regard to criteria.
- (4) Improved simulation must be provided.

f. Princeton U. Report 727

Lateral-Directional Flying Qualities for Power Approach (1966)
by E. Seckel, G. E. Miller and W. B. Nixon

A series of flight tests was conducted with the Princeton Variable Stability Navion (PVSN) aircraft in order to determine the importance of the lateral directional dynamic response parameters and the effect of inflight turbulence on precision carrier approaches. All tests were conducted with constant level of Dutch Roll frequency and spiral mode characteristics. The parameters varied were controlled sensitivity, rolling time constant, dihedral effect, roll to aileron dynamic characteristics, Dutch Roll damping and turbulence effect. All longitudinal parameters were fixed at a constant nominal value. Three axis simulated turbulence moments on the PVSN were obtained by moving the moment controls, aileron, rudder and elevator in proportion to the magnitude of the disturbance and appropriate aircraft derivative. Side by side seating arrangement was used in the PVSN and the cockpit arrangement simulated the crew station layout of the F-4B aircraft. Sixteen test pilots were used in the study and the two year (1964/5) testing effort produced the following number of data runs:

Summer of 1964	46 flights	771 runs
Summer of 1965	20 flights	405 runs

The following conclusions are made from the results of the study:

- (1) Rolling Time Constant and Control Sensitivity

Three classes of rolling mode time constants with specific levels of control sensitivity ($L \delta_a$) and dihedral effect (L_β)

Conclusions

were chosen and it was found that a) The dihedral effect did not appreciably alter the pilot opinion of the optimum control sensitivity or rate of change of control sensitivity. b) The optimum corresponds to a 24 degree bank angle in one second per inch of stick input. c) The control power does not influence the pilot so long as he does not hit the stops but his awareness of the stops is a factor in his opinion. d) An optimum exists for the control sensitivity which is a compromise between too much sensitivity with possible PIO and too little sensitivity with uncomfortably large stick motions.

(2) Rolling Time Constant and Dihedral Effect

The effect on pilot rating of varying the rolling time constant and the dihedral effect at near the optimum control sensitivity indicates that very low values of L_d are unsatisfactory because of the yawing (snaking) oscillations that occur during aircraft maneuver. Large values are undesirable because of the increased turbulence response of the aircraft. The pilots are also more tolerant of variations in the dihedral effect when the roll time constant is small.

(3) Dihedral Effect and Turbulence Disturbances Due to Dihedral Effect

The data indicate that increasing the dihedral effect without increasing the associated turbulence results in only a slight increase in adverse rating.

(4) ϕ/δ_a Zero Location

Plots of K_d/K_{ss} , Cooper Ratings and ω_{ϕ/ω_d} show areas of acceptable pilot ratings.

(5) ϕ/δ_a Transfer Function Zero on Pole Configurations

The data show that the pilot can readily control disturbances in roll and that he finds yaw control in turbulence difficult. This is attributed to a higher sensitivity to rolling motions and better coordination in the hands than in the legs for reaction to disturbance inputs.

(6) Effect of Dutch Roll Damping

Increasing Dutch Roll damping does significantly improve the handling qualities of the low dihedral effect configurations.

(7) Turbulence

Moderately rough day turbulence was simulated and pilot ratings indicate linear relationship to level of turbulence.

- g. AIAA Paper No. 65-794
Flying Qualities Requirements as Related to Control System Complexity (1965) by Charles H. Cromwell and William Koven

By comparing two high performance fleet aircraft, this paper shows how unnecessarily tight flying qualities requirements cause significant increase in flight-control system complexity. Increase in complexity means an increase in number of individual components in the control system. Increasing number of pieces means increase in dollar cost, weight, volume, spare parts, and maintenance required.

As relative examples of complexity, the longitudinal control systems of F-8 Crusader and RA-5C Vigilante were examined. These are two of the Navy's highest performance aircraft. Both aircraft are quite similar aerodynamically. The longitudinal control system of F-8 is a purely mechanical and hydraulic system, without stability or control augmentation, and is what is called a simple system. On the other hand, the longitudinal control system in the A-5 is very complex, with stability augmentation provided by shaped pitch rate gyro signals.

Comparing the original flying qualities, specifications for both airplanes, looking at their basic airplane short period dynamics and their stick force per "g" characteristics then the complexity of the A-5 control system can be traced as a result of the specification requirements. At the time of F-8 procurement the MIL-F08785 longitudinal short period requirement was $\zeta = 0.34$. But, to meet this requirement, a pitch damper was required, and since there was some question as to the validity of this requirement, the requirement was changed to read "satisfactory damping shall be provided". The force to pull limit "g" had to fall in range 21 to 56 pounds. From this loose constraint the very simple control system of the F-8 evolved. For the A-5, although the Detail Specification required only that $\zeta = 0.34$, the designers chose to achieve the constant stick force per "g" and constant aircraft response to control inputs. To get this requirements redundancy had to be introduced and hence complexity becomes necessary in this system for failure protection.

So, in order to maximize an aircraft's usefulness to the fleet it must have good flying qualities and a minimum of flight control system maintenance and spare requirements. Therefore, each new design should be subject to a trade off study to determine which areas of the flight envelopes are critical to the flying qualities of the bare airframe, whether this is a major operational portion of the envelope, and what is the simplest system that can result in satisfactory flying qualities in that envelope.

In conclusion Naval Air System Command desires an optimum aircraft. This does not necessarily mean optimum flying qualities but implies good flying qualities and simple, maintenance-free control system.

h. Effects of Manual Altitude Control and Other Factors on Short Period Handling Quality Requirements (1967) by R. L. Stapleford and I. L. Ashkenas

In this paper several factors which affect short-period handling-quality requirements are reviewed with particular attention paid to manual control of pitch attitude and altitude. The effects of the various short-period parameters on the pilot's closures of these two loops are examined. Correlation between analytical results and experimental data is made for two flight conditions - landing/approach and cruise.

Attitude control is a basic requirement in almost all manual flight situations. Pitch angle, θ , feedback to the elevator, δ_e , is often used by the pilot to stabilize an aircraft. The short period approximate equation of motion for constant airspeed is used in this report and the attitude-to-elevator transfer function is given by:

$$\frac{\theta}{\delta_e} = A_{\phi} \frac{\left(S + \frac{1}{T_{\theta_2}} \right)}{S \left(S^2 + 2\zeta_{sp} \omega_{sp} S + \omega_{sp}^2 \right)}$$

After examining the Bode amplitude asymptotes and root locus for four different combination of ω_{sp} and $1/T_{\theta_2}$ it was found that for good attitude control the pilot would prefer a high short period frequency and relatively high damping regardless of the value of $1/T_{\theta_2}$. However, upper limits on acceptable values of short-period frequency are set by two other factors: 1.) High short-period frequency produced by a very large value of $-M_{\dot{\theta}}$ produces severe pitch response to a vertical gust. 2.) For high short-period frequency a high control sensitivity, M_{δ_e} , must be provided to obtain reasonable control forces per g. But high sensitivity may still present serious problems in trimming the aircraft.

For attitude control, they discuss using simultaneous pilot closure of attitude and altitude loops using two different control techniques: series or parallel closures. In the series closures, equalization in the attitude loop is also effective in the altitude loop; whereas, with parallel closures equalization in the two loops is independent. For the four cases of short-period dynamics (ω / T_{θ_2}), treated, the following conclusions were reached:

- o Low $1/T_{\theta_2}$ results in poor altitude bandwidth.
- o The series closures are beneficial for the low short-period frequency cases because the attitude lead is helpful in altitude loop.
- o The series closures are detrimental for the high frequency cases because the lag in attitude loop degrades the altitude loop.

Contrails

- o For the high short-period frequency cases, better altitude loop bandwidths are obtained if parallel closures are used.

Several other open and closed-loop factors which contribute to short period handling qualities are:

- o Increasing $1/T_{\theta_2}$ increases the altitude and acceleration response to a vertical gust.
- o When $|Z_\alpha|$ is very large the aircraft can be maneuvered with very small angle-of-attack and attitude changes; and the pilot cannot discern the desired pitch changes on a conventional artificial horizon.
- o A large $|Z_\alpha|$ will make the acceleration response of the vehicle much too sensitive.
- o For a very small $|Z_\alpha|$ large attitude excursions are required to get reasonable altitude response.

Experimental data were obtained for two conditions - landing approach and cruise.

The following conclusions, for landing, were reached from analytical and experimental results:

- (1) Satisfactory pilot ratings cannot be achieved if the short-period frequency is below 1 rad/sec.
- (2) Satisfactory ratings can be achieved with $1/T_{\theta_2}$ as low as 0.5 sec^{-1} , if the short-period frequency is in a narrow range and damping is good.
- (3) Increasing $1/T_{\theta_2}$ raises the upper boundary of short-period frequency and improves the rating at the optimum short-period frequency.
- (4) Short-period frequency, damping, $1/T_{\theta_2}$, and control gain must be considered.

Primary requirement for cruise is that ω_{sp} should be greater than 1 rad/sec.

- i. AIAA Paper 68-245
Airplane Flying Qualities Specification Revision (1968)
by C. R. Chalk and R. K. Wilson

This paper discusses the rationale for the changes which are proposed to MIL-F-8785 and demonstrates how they are supported by experimental data. The framework for stating the requirements as well as changes

Contrails

to specific items such as longitudinal short period characteristics, stick force gradients, Dutch Roll and roll control parameters are discussed:

(1) Requirement Framework Changes

- (a) Airplane Classification. The airplane classification has been expanded from three to four, and gross weight with limit load factor identification has been added explicitly to each category.
- (b) Mission Phases. The requirements dealing with damping of the short period and lateral directional oscillation as it applies to "armed" and "unarmed" requirements are now specified in terms of three categories (A, B, and C) which are based on mission phases and control task influence on the requirements.
- (c) Operational States. The operational state of the airplane of interest in specifying handling qualities, is a combination of position in the flight envelope and failure state of the systems influence handling qualities. The concept of handling qualities levels is generated to define a measure of probability associated with the airplane failure state. Three degrees or levels of probability have been introduced to the revised specification.

(2) Requirement Specification Changes

General reorganization of MIL-F-8785 has resulted in elimination of the sections on primary, secondary, power boost and mechanical controls requirements. Three new sections entitled:
a) Characteristics of the Primary Flight Control System
b) Characteristics of Secondary Control Systems
c) Turbulence and Aeroelastic Effects, have been added which provide a more logical grouping of the material covered in the original specification.

(a) Lateral Directional Flying Qualities

- (1) Dutch Roll Root. The basic Dutch Roll requirement proposed in the new specification consists of minimum damping ratio boundaries for $\omega_d < 2$ rad/sec and minimum frequency boundaries for high ζ_d values with a transition from one boundary to the other along lines of nearly constant $\zeta_d \omega_d$.
- (2) Roll Sideslip Coupling. Limiting the degradation of handling qualities due to excitation of the Dutch Roll mode in the roll rate response to a step aileron input is now based on a ratio of P_{osc}/P_{ave} and a function of the phase of the Dutch Roll oscillation in sideslip, ψ_β .

Contrails

(3) Rolling Characteristics. A need to specify limiting values of roll mode time constant is recognized but experimental data to date are still not conclusive as to the exact value which is presently assumed to be one second. The roll control power as a measure of the aircraft maneuverability is now stated in terms of time to bank to specific bank angles depending on airplane class and mission phase.

(b) Longitudinal Flying Qualities.

(1) Static Stability. The revised specification prohibits a periodic divergence in airspeed for all levels of operation.

(2) Phugoid Oscillation. Phugoid damping in terms of damping ratio and time to double amplitude will be added to the new spec.

(3) Flight Path Stability. The landing approach phase is constrained to specific values of climb angle slope versus airspeed (dy/dV).

(4) Short period Root. Short period frequency is expressed as a function of N_z/α and limits have been established for short period damping.

(5) Control Forces. Maneuvering and transient forces are constrained to help eliminate divergence and/or PIO conditions.

j. NATO (AGARD) Report 556
Maneuverability and Gust Response Problems Associated with Low-Altitude, High-Speed Flight (1967) by Ralph C. A'Harrah

This report is a state-of-the-art review of the technology applicable to airplane maneuverability and gust response characteristics in low-altitude, high speed flight. The objectives of the review were:

- o To define any appreciable unbalances in the applicable technology levels between the interested NATO nations,
- o To determine common problem areas requiring additional and immediate attention,
- o To determine technical areas which would appreciably benefit by a review performed by specialists in particular areas or by the AGARD Flight Mechanics Panel.

The author obtained the background material for the report from a literature review and from a personal survey of various aerospace facilities throughout NATO.

Contrails

The author states that the basic problem in low-altitude, high-speed flight is the need to provide an acceptable balance between minimizing the gust response and still maintaining a desirable level of maneuvering response characteristics. The report indicates that the following research and development areas should contribute significantly to the understanding of the low-altitude, high-speed flight problems:

- o Operational low-altitude, high-speed flight experience,
- o investigations conducted on dynamic flight simulators and with variable stability aircraft,
- o flexible wind tunnel model testing techniques, load alleviation and mode suppression programs, and improved analytical techniques.

The report states that the present state-of-the-art flight in the low-altitude, high-speed regime is on a level compatible with that of the other flight regimes. The impact of low-altitude, high-speed flight has stimulated a number of research projects in controls, displays, flying qualities, and gust disturbances. The proper implementation of the results of these studies should be of appreciable benefit, not only in the low-altitude, high-speed flight regime but throughout the flight envelope. The author recommends that the fundamental aircraft parameters related to vehicle responses be documented for past, present, and future aircraft.

The report also makes a specific recommendation to minimize the gust-induced acceleration environment at the pilot's station. To minimize this acceleration environment the report recommends that the longitudinal short-period frequency be increased to a level which will place the rigid body node of pitch and altitude modes at the pilot's location. The report states that the results presented in the report are primarily applicable to relatively small, high-load-factor aircraft; for larger, low-load-factor aircraft the structural dynamic aspects must also be considered.

In discussing the range of acceptable short period frequencies, it is stated that a reference by W. Bihrlé (USAF(FDL) TR 65-198, dated June 1966) suggests that pilots are quite sensitive to their initial impression of the aircraft response to a control input. The report then mentions the possibility that the differences between the Cornell "thumbprint" data and the author's handling quality results, presented in another report (NATO (AGARD) Report 443, April 1963, by R. C. A'Harrah), might be due to the test pilots' sensitivity to their initial impression of the aircraft response to a control input. The two test configurations were at first considered to be equivalent, but a subsequent analysis indicated that the initial aircraft response to control inputs was not the same in the two cases.

k. ICAS Paper 68-17

The Statistical Treatment of Pilot Opinions on Flying Qualities
(1968) by J. Gedeon

The paper describes the statistical properties of a pilot rating poll of flying qualities. The purpose of the investigation of statistical properties was to improve the pilot opinion charts and to be better able to tackle some of the exaggerated ratings of individual pilots.

In all, 532 questionnaires were received and each questionnaire contained 31 questions. A form of Cooper rating scale was used to record the opinions of the pilots. Ratings were obtained for 35 types of flying characteristics; however, only 5 of these were selected for statistical examination. The 5 types selected for statistical examination were the ones rated by the greatest number of pilots. The number of pilots who participated in rating each of the five main types varied from 38 to 70. The paper does not give the total number of pilots participating in the complete study, except that the number of pilots must have been at least 70.

The paper concludes that when the number of pilots participating in the evaluation increases, the distribution of Cooper ratings usually approaches a "binomial-like" distribution. Some of the investigated distributions were dual (two different distributions superimposed) and some of the others were irregular; however, both of these are shown to belong to unacceptable or poor flying characteristics.

A total of 175 distributions were investigated, 88.5% of these closely approximated a binomial distribution, 8.0% were dual distributions, and the remaining 3.5% were irregular. The author states that possibly the dual distributions are obtained when the investigated configuration contains undesirable elements which some pilots consider essential while others consider them less important. The author presents a number of examples to illustrate his statistical analysis; however, he does not present an overall description of the program. The pilots participating in the investigation are described as sailplane pilots, but the nature of the flight test program and the questionnaires used in the investigation are not described.

One of the most useful results presented in the paper appears to be the expression for a confidence limit of the Cooper rating data. For the 90% confidence limit the author derives to the following equation:

$$e_{90} = \frac{0.5}{\sqrt{J}} \sqrt{(X-1)(10-X)},$$

Contrails

where: e_{90} - magnitude of the 90% confidence limit error expressed in Cooper rating scale

j - number of ratings used

X - mean value of the ratings

The author's interpretations of statistical data are based on results plotted in Weibull probability coordinates. The reference cited for the Weibull probability plots is an article by J. N. Berettoni in the August 1964 issue of Industrial Quality Control.

1. Princeton U. (A and MS) Report 777
Comparative Evaluation of Longitudinal Handling Qualities in Carrier Approach (1966) by J. E. Eney

The Princeton Variable Stability Navion (PVSN) aircraft as configured for simulated carrier landings was used in this study to investigate the handling qualities of jet aircraft in power approach. Variable longitudinal feedbacks used in the modified Minneapolis-Honeywell (three axis) E-12 autopilot included a) angle of attack b) pitch rate and c) true airspeed which were combined to alter the M_{α} , $M_{\dot{\alpha}}$ and $M_{\dot{V}}$ derivatives. Aircraft seating arrangement in PVSN included a safety pilot on left side and the test (subject) pilot on right side. No mechanical linkage existed between the test pilot's stick and aircraft elevator surface and the pseudo fly by wire system accommodated electrical gain variations to study the effect of stick to surface gearing (M_{δ}) variations and stick force per "g" variations. All lateral directional parameters were preset to some desired level by each subject pilot. The test sequence consisted of a racetrack pattern which terminated with a simulated approach using 3-1/2 degree glide slope and a constant relative speed of 105 knots. The pilot maintained the source light cluster (meatball) aligned between two horizontal rows of dattern lights which are so arranged to obtain the same accuracy as the Fresnel lens and mirror system onboard aircraft carriers. The test sequence followed in the study consisted of pilot evaluation (as per Cooper Rating Scale) of numerous configurations as generated by varying the electrical feedback gains to achieve alternate levels of damping and frequency. Principal test pilots used in the study were five (5) naval aviators each of which had some carrier experience. Telemetry data from the aircraft included pilot stick force input, stick position, pitch rate and angle of attack. The latter two signals were matched with a ground station simulation of the aircraft autopilot combination and due to the existence of a mismatch between simulation traces and telemetry traces, an adjustment in basic airframe parameters M_{α} , Z_{α} and M_{δ} as used in the simulation was necessary. A canned turbulence capability aboard the PVSN was available but not used due to the inability to alter heave (Δn_z) and roll (ϕ) directly since the aircraft did not have fast acting servo actuators aboard. Number of pilots and number of runs:

Contrails

Pilot Number	1	2	3	4	5
Number of Flights	1	1	2	3	3
Number of Runs/Flights	<u>25</u>	<u>25</u>	<u>25</u>	<u>25</u>	<u>25</u>
Totals	$25 + 25 + 50 + 75 + 75 = 250$ Runs				

Program Results and Conclusions:

- (1) Good agreement exists between results of this study and CAL results for statically stable systems.
- (2) Statically unstable systems results indicate an M_{δ} value significantly higher than 0.061 and the addition of the total control power ($M \times \delta_{MAX}$) as a critical parameter.
- (3) The pilots favored the same control sensitivity (M_{δ}) for the same undamped natural frequency (W_{sp}). This was attributed to a desire on the part of the pilots for a constant angle of attack "gain" regardless of sensitivity or frequency.
- (4) Stick force per g is not a critical item during landing.
- (5) A new criteria for PA in the form of $(L_{\alpha} / V_{\alpha}) / W_{sp}$ versus ζ_{sp} is proposed for inclusion in the MIL-F-8785 revision.
- (6) Application of the C* criterion indicated that configurations satisfying the C* boundaries were indeed well rated. However, some that exceeded the boundaries were also well rated. The author questions the time history concept for application to landing flight conditions due to the envelope length extending over several seconds in time.

m. USAF (FDL) TDR-64-70
Aircraft Motion Analysis, (1965) by J. A. Thelander (DAC)

Data and information are presented in this report for use in the analysis of aircraft motion. This report is a compilation and condensation of the coordinate systems, equations, and general information related to aircraft motion analysis.

The purpose of this report was to provide equations and relations necessary to analyze the motions of aircraft in concise, consistent, and readily available form.

The basic kinematic and dynamic relations for particle and rigid body motion are included. Coordinate Systems and Equations of motion are defined for:

Contrails

- o Particle Motion

 - Rectangular - Coordinate System

 - Spherical - Coordinate System

 - Rotating - Earth Spherical Coordinate

 - Rotating - Earth Flight Path Coordinate

 - Nonrotating - Earth Spherical Coordinate

 - Nonrotating - Earth Flight Path Coordinate

 - Cylindrical - Polar Coordinate System.

- o Rigid - Body Motion (aircraft)

 - Earth Axes

 - Body Axes

 - Principal Axes

 - General Wind Axes

 - Symmetric Wind Axes

 - Wind-Tunnel Stability Axes

 - Nonrolling Axes

Coordinate - System transformation equations are given for both particle and rigid body motion. Force and moment components are developed, and a compilation of conventional stability derivatives is presented. Stability derivatives tables are presented for:

- o Dimensional derivatives - Body axes

- o Nondimensional derivatives - Body axes

- o Nondimensional derivatives - Stability axes

The rigid-body equations of motion are simplified for special flight conditions (steady-straight flight, steady turns, steady pitching flight, steady rolling or spinning flight), and some solutions are given by using the following:

- o Analytical methods

- o Computer methods

- o Approximate solutions

Some material is presented pertaining to instrument reading fuel slosh.

Contrails

APPENDIX II

NORMALIZED LATERAL-DIRECTIONAL EQUATIONS

Roll response characteristics were investigated using normalized equations of motion whose derivation and associated frequency response, time history, and root locus data are presented in this appendix.

1. DERIVATION OF SIMPLIFIED EQUATIONS

Small motion of the aircraft in the lateral-directional planes can be described with a set of three-degree-of-freedom differential equations of the type:

$$\dot{p} = L_p p + L_r r + L_\beta \beta + L_{\delta a} \delta_a + L_{\delta R} \delta_R \quad (B1)$$

$$\dot{r} = N_p p + N_r r + N_\beta \beta + N_{\delta a} \delta_a + N_{\delta R} \delta_R \quad (B2)$$

$$\dot{\beta} = Y_p p + Y_r r + Y_\beta \beta + Y_{\delta a} \delta_a + Y_{\delta R} \delta_R + Y_\phi \int p dt + Y_\psi \int r dt \quad (B3)$$

In developing a roll axis criterion, a "rudder free" condition as recommended in Reference 2 was assumed and the aileron input was limited to a K_i size step. As a result,

$$\delta_R = 0 \quad (B4)$$

$$\delta_a = K_i / \lambda \quad (B5)$$

Where λ is the Laplace operator utilizing F-4 aircraft aerodynamic data, it can be shown that

$$Y_r \approx -1.0 \quad (B6)$$

$$Y_p \approx Y_\psi \approx Y_{\delta a} \approx 0 \quad (B7)$$

Substituting Equations B4 through B7 into Equation B3 gives,

$$r \approx -\dot{\beta} + Y_\beta \beta + Y_\phi \int p dt \quad (B8)$$

Substituting Equations B4 through B8 into Equations B1 and B2, and rearranging gives,

$$\dot{p} - L_p p - L_r Y_\phi \int p dt = (L_\beta + L_r Y_\beta) \beta - L_r \dot{\beta} + L_{\delta a} \delta_a \quad (B9)$$

$$\ddot{\beta} - (N_r + Y_\beta) \dot{\beta} + (N_\beta + N_r Y_\beta) \beta = (Y_\phi - N_p) p - N_r Y_\phi \int p dt - N_{\delta a} \delta_a \quad (B10)$$

Available F-4 aircraft data indicate that

$$(-L_r)/(L_\beta + L_r Y_\beta) \approx 0 \quad (B11)$$

$$(L_r Y_\phi)/L_p \approx 0 \quad (B12)$$

Then defining,

$$l_p = L_p$$

$$l_\beta = L_\beta + L_r Y_\beta$$

$$l_{\delta a} = L_{\delta a}$$

$$n_r = N_r + Y_\beta \quad (B13)$$

$$n_\beta = N_\beta + N_r Y_\beta$$

$$n_p = N_p - Y_\phi$$

$$n_\phi = N_r Y_\phi$$

$$n_{\delta a} = N_{\delta a}$$

and substituting into Equations B9 and B10 results in the following simplified dimensional equations,

$$(\lambda - l_p)\bar{p} = l_\beta \bar{\beta} + l_{\delta a} \bar{\delta}_a \quad (B14)$$

$$(\lambda^2 - N_r \lambda + N_\beta)\bar{\beta} = -n_p \bar{p} - n_{\delta a} \bar{\delta}_a - n_\phi \bar{\phi} \quad (B15)$$

2. DERIVATION OF NORMALIZED EQUATIONS

Normalization of the above equations was based on a need for further simplification and restatement in terms of the roll and yaw axis handling quality parameters. The amplitude normalization factors selected consisted of a roll rate parameter (P_{SS}) and a sideslip parameter (β_{SS}) obtained from the above equations by arbitrarily setting $n_\phi = 0$. The resulting equations for these parameters are,

$$P_{SS} = \frac{l_\beta n_{\delta a} - l_{\delta a} n_\beta}{l_p n_\beta - l_\beta n_p} K_1 \quad (B16)$$

Contrails

$$\beta_{SS} = \frac{l \delta a^n_p - l_p^n \delta a K_i}{l_p^n \beta - l \beta^n_p} \quad (B17)$$

Incorporating these definitions into Equations B14 and B15 gives:

$$\left(\frac{\lambda}{-l_p} + 1\right) \left(\frac{p}{P_{SS}}\right) = \left(\frac{-l \beta}{l_p} \right) \left(\frac{\beta_{SS}}{P_{SS}}\right) \left(\frac{\beta}{\beta_{SS}}\right) + \left(\frac{-l \delta a}{l_p} \right) \left(\frac{K_i}{P_{SS}}\right) \left(\frac{\delta a}{K_i}\right) \quad (B18)$$

$$\left(\frac{\lambda^2}{n_\beta} - \frac{n_r \lambda + 1}{n_\beta}\right) \left(\frac{\beta}{\beta_{SS}}\right) = \left(\frac{-n_p}{n_\beta}\right) \left(\frac{P_{SS}}{\beta_{SS}}\right) \left(\frac{P}{P_{SS}}\right) + \left(\frac{n \delta a K_i}{n_\beta \beta_{SS}}\right) \left(\frac{\delta a}{K_i}\right) + \left(\frac{-n \phi}{n_\beta}\right) \left(\frac{P_{SS}}{\beta_{SS}}\right) \left(\frac{\phi}{P_{SS}}\right) \quad (B19)$$

Which can be expressed in normalized forms,

$$(T_0 \lambda + 1) \bar{P}_N = X_1 \bar{\beta}_N + (1 - X_1) \bar{\Delta}_a \quad (B20)$$

$$\left(\frac{\lambda^2}{\omega_o^2} + \frac{2\zeta_o}{\omega_o} \lambda + 1\right) \bar{\beta}_N = X_2 \bar{P}_N + (1 - X_2) \bar{\Delta}_a + X_3 \bar{\phi}_N \quad (B21)$$

With the following definitions:

$$\begin{aligned} \bar{P}_N &= P/P_{SS} \\ \bar{\beta}_N &= \beta/\beta_{SS} \\ \bar{\Delta}_a &= \delta a/K_i \\ \bar{\phi}_N &= \phi/P_{SS} \end{aligned} \quad (B22)$$

$$T_0 = 1/-l_p$$

$$\zeta_o = (-n_r)/(2\sqrt{n_\beta})$$

$$\omega_o = \sqrt{n_\beta}$$

$$X_1 = (-l \beta \beta_{SS})/(l_p P_{SS})$$

$$X_2 = (-n_p P_{SS})/(n_\beta \beta_{SS})$$

$$X_3 = (-n_\phi P_{SS})/(n_\beta \beta_{SS})$$

A block diagram of the normalized equation is presented in Figure 42. As shown in the equations and in the block diagram, the normalized parameters (X_1 , X_2 and X_3) couple the lateral and directional axes. Depending on the algebraic sign of these parameters, the coupling can be either stabilizing or destabilizing.

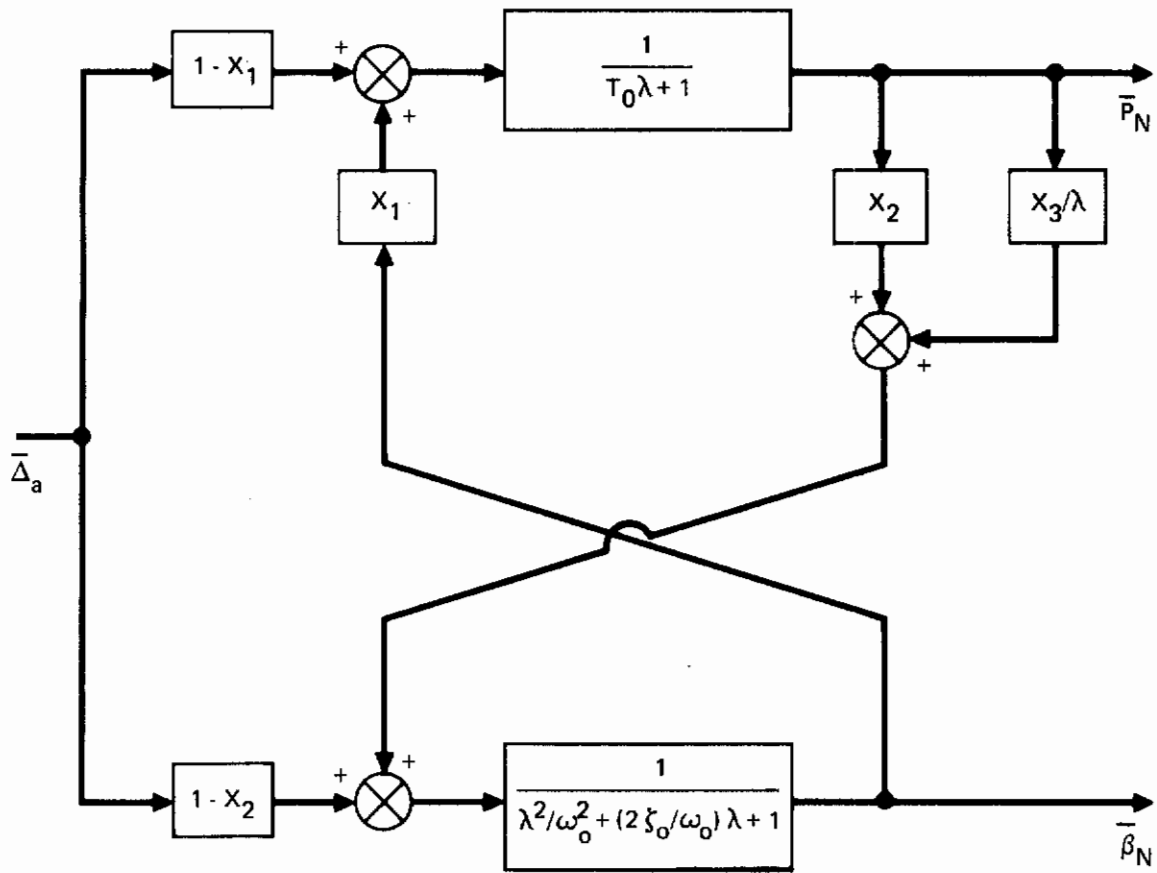

FIGURE 42
NORMALIZED EQUATIONS OF MOTION BLOCK DIAGRAM

Contrails

The closed loop transfer function for normalized roll rate and sideslip angle can be expressed as,

$$\frac{\bar{P}_N}{\bar{\Delta}_a} = \frac{\lambda \left[\frac{(1-X_1)}{\omega_o^2} \lambda^2 + \frac{2(1-X_1)\zeta_o}{\omega_o} \lambda + (1 - X_1 X_2) \right]}{\left(\frac{T_o}{\omega_o^2} \right) \lambda^4 + \left(\frac{2\zeta_o T_o}{\omega_o^2} + \frac{1}{\omega_o^2} \right) \lambda^3 + (T_o + \frac{2\zeta_o}{\omega_o}) \lambda^2 + (1 - X_1 X_2) \lambda - X_1 X_3} \quad (B23)$$

$$\frac{\bar{B}_N}{\bar{\Delta}_a} = \frac{(1 - X_2) T_o \lambda^2 + (1 - X_1 X_2) \lambda + X_3 (1 - X_1)}{\left(\frac{T_o}{\omega_o^2} \right) \lambda^4 + \left(\frac{2\zeta_o T_o}{\omega_o^2} + \frac{1}{\omega_o^2} \right) \lambda^3 + (T_o + \frac{2\zeta_o}{\omega_o}) \lambda^2 + (1 - X_1 X_2) \lambda - X_1 X_3} \quad (B24)$$

3. ROLL RATE CHARACTERISTICS

F-4 aircraft values for the coupling, modal, and normalization parameters are given in Table XI for various combinations of Mach number/altitude flight conditions. The data show that the coupling parameter values fall into the following ranges,

$$-0.2 \leq X_1 \leq +0.2$$

$$0 \leq X_1 X_2 \leq -0.12 \quad (B25)$$

$$0 \leq X_1 X_3 \leq -0.11$$

with the products, generally very small, as is expected. Associating these value ranges with the normalized roll rate equation indicates an obvious predominance of the roll axis time constant T_o in the coupled equations. Depending on stipulated assumption, the effective roll rate transfer function can be expressed in one of several ways:

o Single Degree of Freedom

With the assumption that $X_1=0$, the coupled roll rate is reduced to a single-degree-of-freedom and expressed as,

$$\frac{\bar{P}_N}{\bar{\Delta}_a} = \frac{1}{T_o \lambda + 1} \quad (B26)$$

o Three Degree of Freedom (No Spiral)

To eliminate the spiral mode, the third coupling parameter assumes a zero value ($X_3=0$), which gives:

**TABLE XI
F-4 AIRCRAFT LATERAL-DIRECTIONAL DATA**

Flight Condition		Normalization Parameters		Modal Parameters			Coupling Parameters		
Mach	Altitude	P_{SS}	β_{SS}	T_o	ζ_o	ω_o	X_1	X_1X_2	X_1X_3
0.5	5,000	4.473	0.1098	0.5593	0.1039	2.227	-0.2057	-0.1052	-0.0313
0.84	SL	6.314	-0.0150	0.3249	0.1216	3.980	0.0236	-0.0540	-0.0140
0.85	5,000	6.542	-0.0095	0.3584	0.1140	3.704	0.0138	-0.0591	-0.0137
0.85	25,000	6.748	0.0497	0.6363	0.0810	2.538	-0.0828	-0.0972	-0.0183
0.9	15,000	6.858	0.0026	0.4469	0.0964	3.283	-0.0040	-0.0685	-0.0141
0.9	35,000	6.636	0.0820	0.8584	0.0660	2.245	-0.1637	-0.1151	-0.0199
1.2	5,000	3.736	-0.0377	0.3628	0.0457	5.811	0.1240	-0.0135	-0.0009
1.2	15,000	5.400	-0.0293	0.4397	0.1027	4.971	0.0624	-0.0239	-0.0084
1.2	35,000	7.222	0.0048	0.7353	0.0700	3.359	-0.0068	-0.0416	-0.0082
1.2	45,000	7.469	0.0433	1.0852	0.0550	2.698	-0.0678	-0.0578	-0.0093
1.5	15,000	3.461	-0.0246	0.4427	0.1204	5.289	0.1078	-0.0080	-0.0099
1.5	25,000	4.620	-0.0073	0.5442	0.0968	4.549	0.0182	-0.0440	-0.0073
1.5	35,000	5.479	-0.0069	0.7092	0.0807	3.661	0.0121	-0.0191	-0.0071
1.5	45,000	6.167	0.0134	0.9974	0.0601	3.102	-0.0201	-0.0189	-0.0056
1.8	55,000	6.733	0.0276	1.5947	0.0467	2.458	-0.0379	-0.0048	-0.1103
2.1	36,000	4.019	-0.0285	0.7332	0.0751	3.565	0.0376	-0.0007	-0.0801
2.1	45,000	4.888	-0.0158	0.9647	0.0588	2.971	0.0160	-0.0015	-0.0702

$$\frac{\bar{P}_N}{\Delta_a} = \frac{\left(\frac{1-X_1}{\omega_o^2}\right)\lambda^2 + 2\left(\frac{1-X_1}{\omega_o}\right)\lambda + (1 - X_1X_2)}{\left(\frac{T_o}{\omega_o^2}\right)\lambda^4 + \left(\frac{2\zeta_o T_o}{\omega_o^2}\right)\lambda^3 + (T_o + \frac{2\zeta_o}{\omega_o})\lambda^2 + (1 - X_1X_2)} \quad (B27)$$

With this combination, the Dutch Roll term in the roll response expression is preserved but the long term effect of the spiral mode is removed. Even when X_3 is included (not set to zero), its effect in the roll axis is barely discernable from short period response data.

Due to roll axis normalization, the "type 0" transfer functions given in these equations have a "steady state" gain of unity. Consequently, the normalization parameter P_{SS} becomes the dimensional gain relating steady roll rate to aileron step command input. The values of P_{SS} for various flight conditions, as well as the corresponding Dutch Roll frequency, damping, and roll time constant resulting from solution of the characteristic equation, are also shown in Table XI. A series of constant frequency lines can be drawn by interpreting between the undamped natural frequency values given in the table and plotting them versus Mach number and altitude.

For the F-4 aircraft these data are presented in Figure 43 and the X_1 coupling parameter relationship to the undamped natural frequency is shown in Figure 44.

4. SIDESLIP CHARACTERISTICS

The unmodified sideslip transfer function given in Equation B24 expresses the directional response to aileron inputs in terms of coupled dynamic motions. The sideslip transfer function is characteristically a second order over a fourth order which includes the roll rate dynamics and spiral effects. Similar to the roll axis modifications, the directional response can be expressed in several modified ways:

o Two Degrees of Freedom

Removal of roll axis coupling can be achieved by defining $X_2 = X_3 = 0$. Substituting into equation B24, gives:

$$\frac{\bar{\beta}_N}{\Delta_a} = \frac{1}{\frac{1}{\omega_o^2} \lambda^2 + \frac{2\zeta_o}{\omega_o} \lambda + 1} \quad (B28)$$

which has a unity "gain" for a normalized step input. The equivalent steady state value for dimensional sideslip is equal to β_{SS} , the data for which, is given in Table XI. Variation of β_{SS} with dynamic pressure is shown in Figure 45.

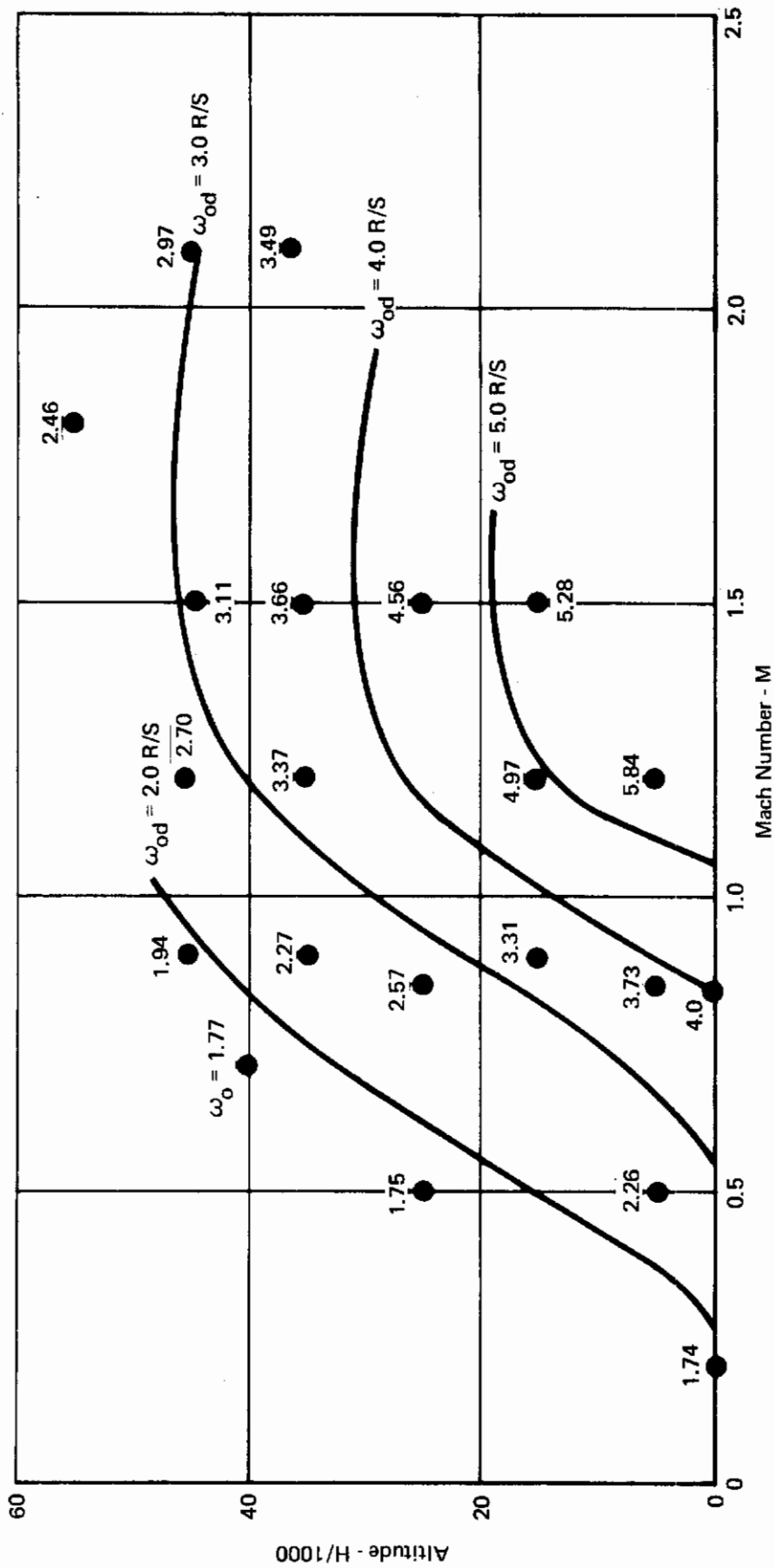

FIGURE 43
F-4 AIRCRAFT DUTCH ROLL FREQUENCY PLOT

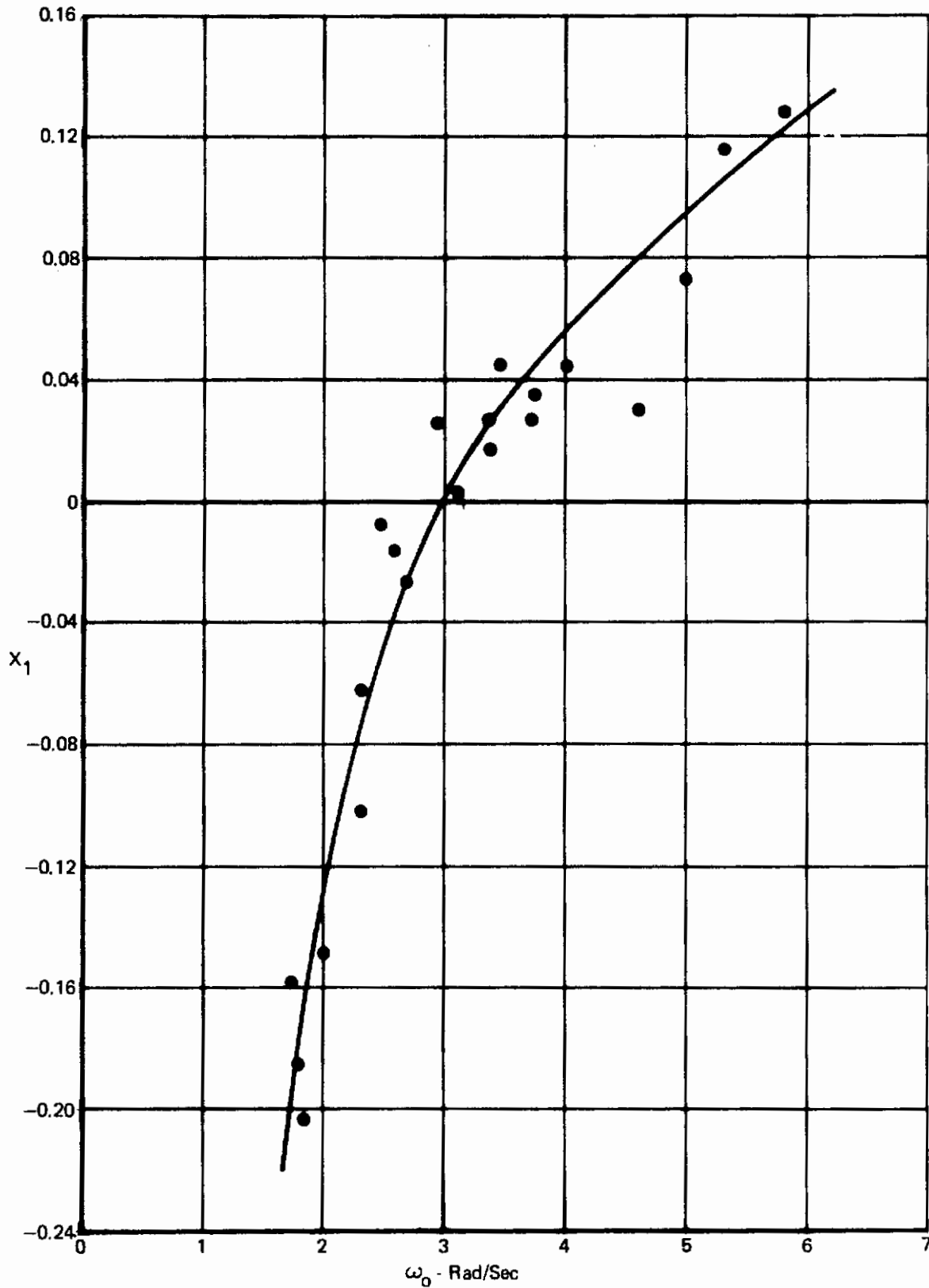
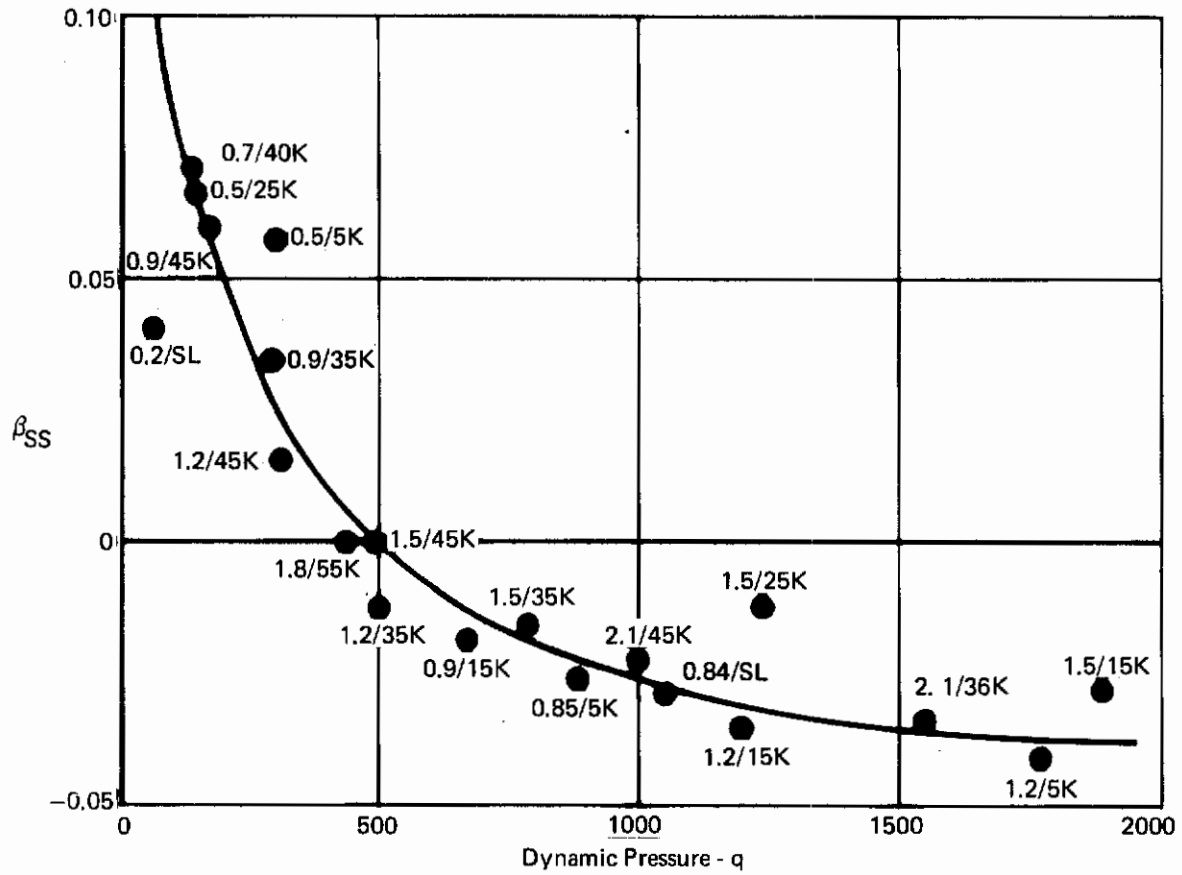

FIGURE 44
COUPLING PARAMETER RELATIONSHIP TO DUTCH ROLL FREQUENCY



**FIGURE 45
SIDESLIP VARIATION WITH DYNAMIC PRESSURE**

o Three Degree of Freedom (Spiral Pole Located at Origin)

Contrary to the "Type 0" system representation for roll rate, the normalized sideslip equation with the spiral pole location at the origin results in a "type 1" system which integrates the aileron command input during steady state operation. Equation B24 can be re-written with $X_1 = 0$, to represent this condition,

$$\frac{\bar{\beta}_N}{\Delta_a} = \frac{(1 - X_2)T_O\lambda^2 + \lambda + X_3}{\lambda(T_O\lambda + 1)\left(\frac{\lambda^2}{\omega_o^2} + \frac{2\zeta_o}{\omega_o}\lambda + 1\right)} \quad (B29)$$

The dimensional (unnormalized) integration gain implicit in Equation B29, can be expressed as,

$$K_\beta = X_3\beta_{SS} \quad (B30)$$

where β_{SS} is the normalization parameter defined above. Computing the integration gain from the values in Table XI and plotting it versus velocity depicts a decreasing magnitude relationship as seen in Figure 46. From these two figures, it is evident that the sideslip magnitude decreases as airspeed increases.

5. FREQUENCY RESPONSE AND ROOT LOCUS PLOTS

Frequency response and root locus plots for the above transfer functions equations are well known and can be easily constructed using the data given in Table XI. They are not repeated here, to avoid unnecessary redundancy. In addition, the aerodynamic parameters implicit in the above equations have been extensively investigated as to how they influence the dynamic characteristics and transient response properties reflected in the above equations. Several good reports in current literature, which describe analysis results of aircraft lateral-directional dynamics, are given as References 9 and 10 for further information.

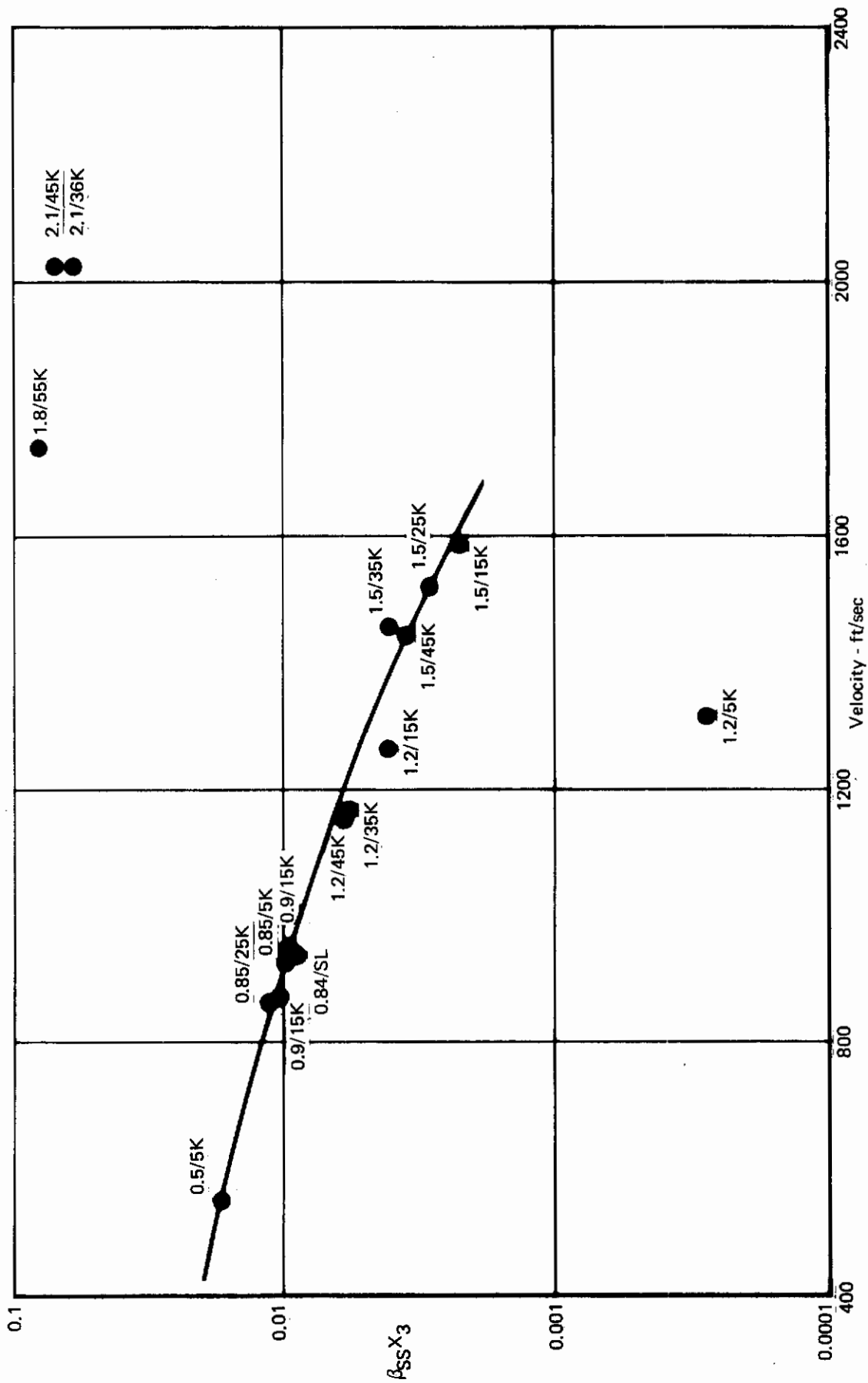

FIGURE 46
SIDESLIP INTEGRATION GAIN VALUE

APPENDIX III

TRACKING EQUATIONS

The investigation of three axis flight path control requirements as related to the gunnery and bombing aiming task involves derivation of tracking loop equations and identification of parameter sensitivity on overall performance. In concert with this approach, a mathematical definition of the elevation and lateral tracking errors between the attacking aircraft's gunline and its line of sight to the target is presented. Linearized block diagrams of the elevation and lateral fire control modes for tracking both aerial and stationary ground targets are developed. These block diagrams illustrate the relationships among the airframe dynamics, augmentation systems, lead computation, pilot configuration, and the geometry dynamics of the visual tracking error of the target with respect to the gunline.

1. DERIVATION OF THE TRACKING ERRORS BETWEEN THE LINE OF SIGHT VECTOR AND THE GUNLINE

The elevation and lateral tracking errors between the attacking aircraft's gunline and its line of sight to the target are developed. These tracking errors are derived in terms of the attacking aircraft's velocity, angle of attack, sideslip and body rates, the tracking range, and the target's velocity components defined in earth coordinates.

The angular velocity of the line of sight vector relative to the attacking aircraft's gunline is the difference between $\bar{\Omega}_L$, the angular velocity of the line of sight, and $\bar{\Omega}_G$, the angular velocity of the gunline.

$$\bar{\Omega}_{L/G} = \bar{\Omega}_L - \bar{\Omega}_G \quad (C1)$$

With reference to Figure 43, $\bar{\Omega}_{L/G}$ is defined in terms of θ_{ET} and θ_{LT} , the elevation and lateral tracking error rates of the line of sight vector with respect to the gunline, as

$$\bar{\Omega}_{L/G} = (\omega_{rp} - \dot{\theta}_{LT} \sin \theta_{ET}) \bar{i}_r + \dot{\theta}_{ET} \bar{i}_e + \dot{\theta}_{LT} \cos \theta_{ET} \bar{i}_d \quad (C2)$$

The unit vectors ($\bar{i}_r, \bar{i}_e, \bar{i}_d$) define the line of sight coordinate system.

The elevation and lateral tracking rates of the line of sight with respect to the gunline are expressed in terms of the line of sight components of $\bar{\Omega}_L$ and $\bar{\Omega}_G$ as:

$$\dot{\theta}_{ET} = \Omega_{Le} - \Omega_{Ge} \quad (C3)$$

$$\dot{\theta}_{LT} = (\Omega_{Ld} - \Omega_{Gd}) / \cos \theta_{ET} \quad (C4)$$

The e and d components of $\bar{\Omega}_G$ are the attacking aircraft's body rates, resolved into the line of sight coordinate system through the gun angle orientation with respect to the body axis, and the tracking error orientation of the line of sight with respect to the gunline (Figures 47 and 48).

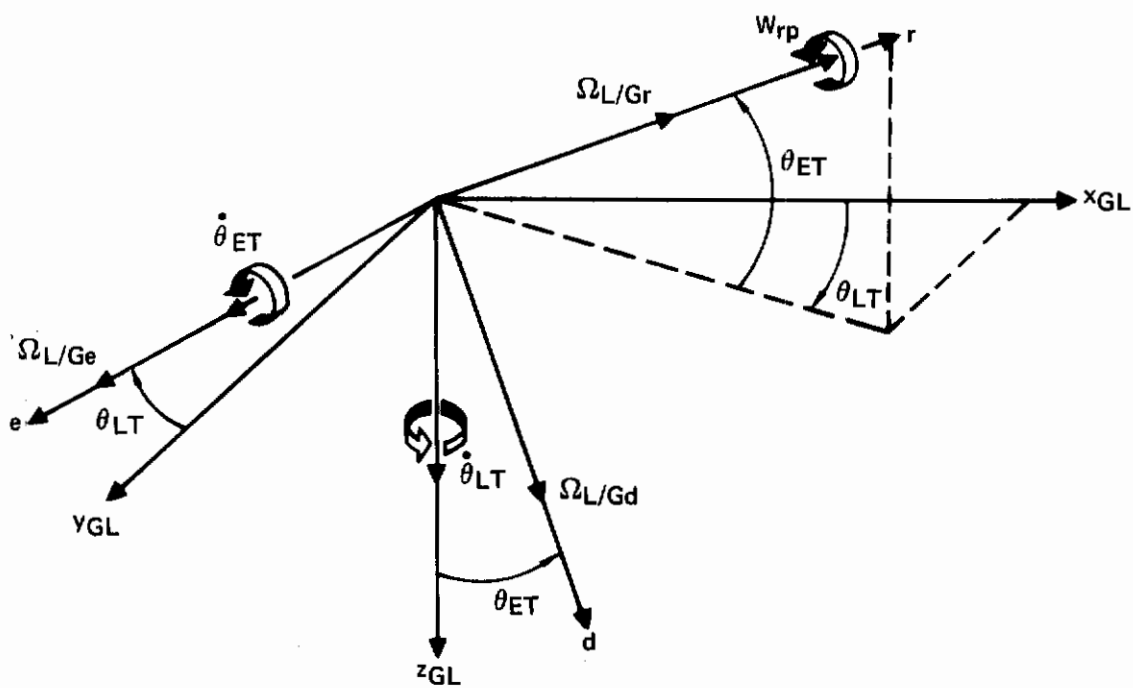

FIGURE 47
LINE OF SIGHT ERROR RATES WITH RESPECT TO GUNLINE COORDINATES
(x_{GL} , y_{GL} , z_{GL}) AND THE LINE OF SIGHT COORDINATES (r , e , d)

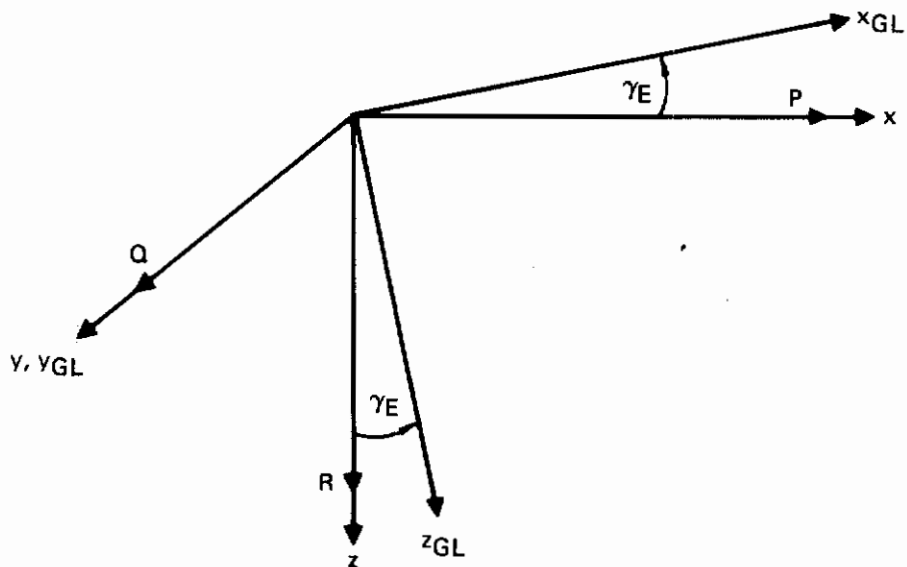

FIGURE 48
AIRCRAFT'S BODY RATES WITH RESPECT TO THE GUNLINE COORDINATES
(x_{GL} , y_{GL} , z_{GL}) AND THE BODY AXIS (x , y , z) COORDINATES

Contrails

$$\begin{bmatrix} \Omega_{Gr} \\ \Omega_{Ge} \\ \Omega_{Gd} \end{bmatrix} = \begin{bmatrix} \cos\theta_{LT} \cos\theta_{ET} & \sin\theta_{LT} \cos\theta_{ET} & -\sin\theta_{ET} \\ -\sin\theta_{LT} & \cos\theta_{LT} & 0 \\ \cos\theta_{LT} \sin\theta_{ET} & \sin\theta_{LT} \sin\theta_{ET} & \cos\theta_{ET} \end{bmatrix} \begin{bmatrix} \cos\gamma_E & 0 & -\sin\gamma_E \\ 0 & 1 & 0 \\ \sin\gamma_E & 0 & \cos\gamma_E \end{bmatrix} \begin{bmatrix} p \\ q \\ r \end{bmatrix} \quad (C5)$$

The e and d components of the line of sight's angular velocity, Ω_L , are defined in terms of the relative range and the relative velocity vector's e and d components between the target and attacking aircraft as

$$\Omega_{Le} = -V_{rd}/R \quad (C6)$$

$$\Omega_{Ld} = V_{re}/R \quad (C7)$$

The relative velocity's e and d components are derived as follows. The target velocity components assumed to be defined in earth coordinates are transformed to body axis components by the Euler angle transformation (Figure 49).

$$\begin{bmatrix} V_{Tx} \\ V_{Ty} \\ V_{Tz} \end{bmatrix} = \begin{bmatrix} \cos\psi \cos\theta & \sin\psi \cos\theta & -\sin\theta \\ \cos\psi \sin\theta \sin\phi & \sin\psi \sin\theta \sin\phi & \sin\theta \cos\phi \\ -\sin\psi \cos\phi & +\cos\psi \cos\phi & \\ \cos\psi \cos\theta \sin\phi & \cos\theta \sin\psi \sin\phi & \cos\theta \cos\phi \\ +\sin\psi \sin\phi & -\cos\psi \sin\phi & \end{bmatrix} \begin{bmatrix} V_{TX} \\ V_{TY} \\ V_{TZ} \end{bmatrix} \quad (C8)$$

The attacking aircraft's velocity vector, which is oriented along the V axis of the wind axis (Figure 50) is transformed to body axis components by the wind angle transformation.

$$\begin{bmatrix} V_{Ax} \\ V_{Ay} \\ V_{Az} \end{bmatrix} = \begin{bmatrix} V \cos\alpha \cos\beta \\ V \cos\alpha \sin\beta \\ V \sin\alpha \end{bmatrix} \quad (C9)$$

The relative velocity is defined in the body axis coordinates as

$$\begin{bmatrix} V_{rx} \\ V_{ry} \\ V_{rz} \end{bmatrix} = \begin{bmatrix} V_{Tx} - V \cos\alpha \cos\beta \\ V_{Ty} - V \cos\alpha \sin\beta \\ V_{Tz} - V \sin\alpha \end{bmatrix} \quad (C10)$$

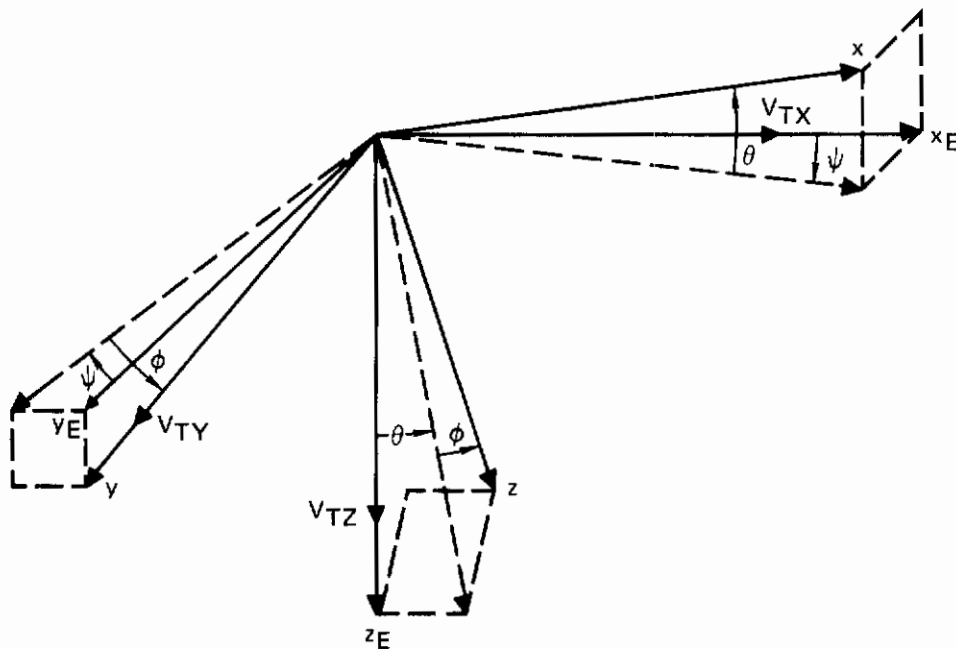

FIGURE 49
BODY AXIS (x, y, z) COORDINATES WITH RESPECT TO THE EARTH AXIS
(x_E, y_E, z_E) COORDINATES

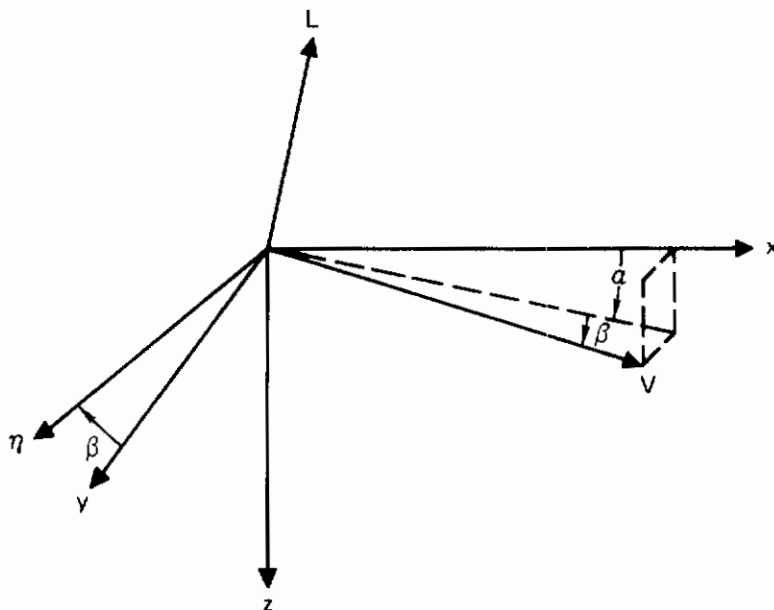

FIGURE 50
WIND AXIS COORDINATES (V, η, L) WITH RESPECT TO THE BODY
AXIS COORDINATES (x, y, z)

Contrails

The body axis relative velocity components are resolved into the line of sight coordinate system through the gun angle orientation relative to the body axis, and the tracking error orientation of the line of sight with respect to the gunline.

The relative velocity components in the line of sight coordinates are:

$$\begin{bmatrix} V_{rr} \\ V_{re} \\ V_{rd} \end{bmatrix} = \begin{bmatrix} \cos\theta_{LT}\cos\theta_{ET} & \sin\theta_{LT}\cos\theta_{ET} & -\sin\theta_{ET} \\ -\sin\theta_{LT} & \cos\theta_{LT} & 0 \\ \cos\theta_{LT}\sin\theta_{ET} & \sin\theta_{LT}\sin\theta_{ET} & \cos\theta_{ET} \end{bmatrix} \begin{bmatrix} \cos\gamma_E & 0 & -\sin\gamma_E \\ 0 & 1 & 0 \\ \sin\gamma_E & 0 & \cos\gamma_E \end{bmatrix} \begin{bmatrix} V_{rx} \\ V_{ry} \\ V_{rz} \end{bmatrix} \quad (C11)$$

Substituting Ω_{Ge} and Ω_{Gd} , defined by Equation C5 and Ω_{Le} and Ω_{Ld} , defined by Equations C6, C7, and C11 into Equations C3 and C4 the tracking rates of the line of sight with respect to the gunline are:

$$\begin{bmatrix} \dot{\theta}_{LT} \\ \dot{\theta}_{ET} \end{bmatrix} = \begin{bmatrix} -\sin\theta_{LT}\sec\theta_{ET} & \cos\theta_{LT}\sec\theta_{ET} & 0 \\ -\cos\theta_{LT}\sin\theta_{ET} & -\sin\theta_{LT}\sin\theta_{ET} & -\cos\theta_{ET} \end{bmatrix} \begin{bmatrix} \cos\gamma_E & 0 & -\sin\gamma_E \\ 0 & 1 & 0 \\ \sin\gamma_E & 0 & \cos\gamma_E \end{bmatrix}$$

$$\frac{1}{R} \left\{ \begin{bmatrix} \cos\psi\cos\theta & \sin\psi\cos\theta & -\sin\theta \\ \cos\psi\sin\theta\sin\phi & \sin\psi\sin\theta\sin\phi & \sin\theta\cos\phi \\ -\sin\psi\cos\phi & +\cos\psi\cos\phi & \\ \cos\psi\cos\phi\sin\theta & \cos\phi\sin\psi\sin\theta & \cos\phi\cos\theta \\ +\sin\psi\sin\phi & -\cos\psi\sin\phi & \end{bmatrix} \begin{bmatrix} V_{TX} \\ V_{TY} \\ V_{TZ} \end{bmatrix} - \begin{bmatrix} V\cos\alpha & \sin\beta \\ V\cos\alpha & \sin\beta \\ V\sin\alpha \end{bmatrix} \right\}$$

$$- \begin{bmatrix} \cos\theta_{LT}\tan\theta_{ET} & \sin\theta_{LT}\tan\theta_{ET} & 1 \\ -\sin\theta_{LT} & \cos\theta_{LT} & 0 \end{bmatrix} \begin{bmatrix} \cos\gamma_E & 0 & -\sin\gamma_E \\ 0 & 1 & 0 \\ \sin\gamma_E & 0 & \cos\gamma_E \end{bmatrix} \begin{bmatrix} \rho \\ q \\ r \end{bmatrix} \quad (C12)$$

The elevation and lateral tracking errors between the line of sight vector and the attacking aircraft's gunline are determined by integrating $\dot{\theta}_{ET}$ and $\dot{\theta}_{LT}$.

$$\theta_{ET} = \int_{t_0}^t \dot{\theta}_{ET} dt + \theta_{ET}(t_0) \quad (C13)$$

$$\theta_{LT} = \int_{t_0}^t \dot{\theta}_{LT} dt + \theta_{LT}(t_0) \quad (C14)$$

2. LINEARIZED BLOCK DIAGRAMS OF GUNNERY ELEVATION AND LATERAL TRACKING MODES FOR AERIAL AND GROUND TARGETS

Linearized block diagrams of the elevation and lateral fire control modes for tracking both aerial and stationary ground targets are described. Figure 51 functionally illustrates the relationships among the airframe dynamics, augmentation systems, lead computation, pilot configuration and the geometry of the visual tracking errors of the target with respect to the gunline. In this appendix the linear functional relationships of the angular orientation of the line of sight with respect to the gunline to the airframe's angular dynamics are derived.

For these derivations it is assumed that the attacking aircraft is in a steady state one g flight with wings level, and the deviations of the aircraft's angular dynamics from its equilibrium state are small. The aircraft has a flight path orientation in the plane of symmetry and its arbitrary initial heading angle is zero. For aerial targets the target's velocity is assumed to be approximately colinear with the attacker's velocity, and for ground targets the target velocity is zero.

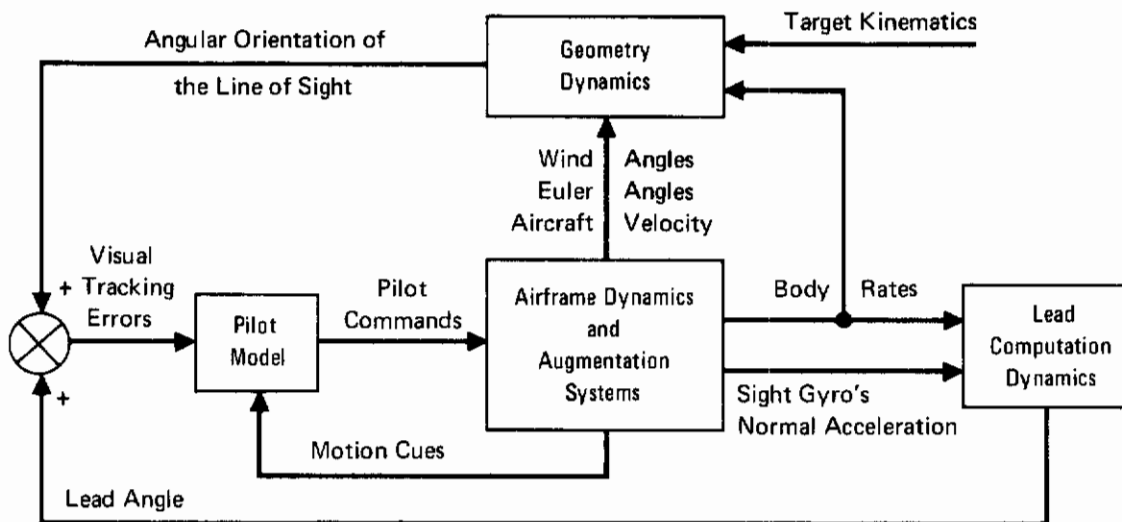

FIGURE 51
FIRE CONTROL MODE

Contrails

Under the assumptions that the elevation and lateral tracking errors of the line of sight with respect to the target, the angle of attack, sideslip, roll and heading attitudes are small, then the trigometric functions of these small angles can be linearized. Consequently, the elevation and lateral tracking error rates of the target with respect to the gunline, as described by Equation C12 are rewritten as:

$$\begin{aligned} \dot{\theta}_{ET} = & -1/R \left\{ \cos \gamma_E \left[(V_{TX} + V_{TY}\Psi) \cos \theta - V_{TZ} \sin \theta - V \right] \right. \\ & \left. - \sin \gamma_E \left[V_{TZ} \cos \theta + (V_{TX} + V_{TY}\Psi) \sin \theta - V \alpha - (V_{TY} - V_{TX}\Psi) \phi \right] \right\} \theta_{ET} \\ & - 1/R \left\{ \cos \gamma_E \left[(V_{TX} + V_{TY}\Psi) \sin \theta + V_{TZ} \cos \theta - V \alpha - (V_{TY} - V_{TX}\Psi) \phi \right] \right. \\ & \left. + \sin \gamma_E \left[(V_{TX} + V_{TY}\Psi) \cos \theta - V_{TZ} \sin \theta - V \right] \right\} \\ & + \theta_{LT} \cos \gamma_E p - q - \theta_{LT} \sin \gamma_E r \end{aligned} \quad (C15)$$

$$\begin{aligned} \dot{\theta}_{LT} = & -1/R \left\{ \cos \gamma_E \left[(V_{TX} + V_{TY}\Psi) \cos \theta - V_{TZ} \sin \theta - V \right] \right. \\ & \left. - \sin \gamma_E \left[V_{TZ} \cos \theta + (V_{TX} + V_{TY}\Psi) \sin \theta - V \alpha \right] \right\} \theta_{LT} \\ & + 1/R \left\{ \left[V_{TX} \cos \theta + (V_{TX} + V_{TY}\Psi) \sin \theta \right] \phi \right. \\ & \left. + (V_{TY} - V_{TX}\Psi) \phi \theta_{LT} + V_{TY} - V_{TX}\Psi - V \beta \right\} \\ & - (p \cos \gamma_E - r \sin \gamma_E) \theta_{ET} - (r \cos \gamma_E + p \sin \gamma_E) \end{aligned} \quad (C16)$$

Assuming that Equations C15 and C16 represent the equilibrium elevation and lateral tracking rates of the line of sight with respect to the gunline, and that the coupling between the angular dynamics of the elevation and lateral channels is negligible, the first order deviations of these tracking rates are:

$$\Delta \dot{\theta}_{ET} = \frac{\partial \dot{\theta}_{ET}}{\partial \theta_{ET}} \Delta \theta_{ET} + \frac{\partial \dot{\theta}_{ET}}{\partial \theta} \Delta \theta + \frac{\partial \dot{\theta}_{ET}}{\partial \alpha} \Delta \alpha + \frac{\partial \dot{\theta}_{ET}}{\partial q} \Delta q \quad (C17)$$

$$\Delta \dot{\theta}_{LT} + \frac{\partial \dot{\theta}_{LT}}{\partial \theta_{LT}} \Delta \theta_{LT} + \frac{\partial \dot{\theta}_{LT}}{\partial \Psi} \Delta \Psi + \frac{\partial \dot{\theta}_{LT}}{\partial \phi} \Delta \phi + \frac{\partial \dot{\theta}_{LT}}{\partial \beta} \Delta \beta + \frac{\partial \dot{\theta}_{LT}}{\partial p} \Delta p + \frac{\partial \dot{\theta}_{LT}}{\partial r} \Delta r \quad (C18)$$

For the elevation tracking rate the following assumptions are made about the second order effects of the angular deviations:

$$\dot{\theta} = q \quad (C19)$$

$$\theta_{ET} \Delta \alpha = 0 \quad (C20)$$

Contrails

$$\theta_{ET} \Delta\theta = 0 \quad (C21)$$

$$(V_{TY} - V_{TX}\Psi)\phi = 0 \quad (C22)$$

For the lateral tracking rate the following assumptions are made about the second order effects of the angular deviations:

$$\Psi = R/\cos\theta \quad (C23)$$

$$\theta_{ET} = 0 \quad (C24)$$

$$(-V_{TX}\Psi + V_{TY})\phi \theta_{LT}/R = 0 \quad (C25)$$

$$\Delta\Psi\phi = 0 \quad (C26)$$

Expanding Equations C17 and C18 under the assumptions defined by Equations C19 through C26 the perturbations of the elevation and lateral tracking rates of the line of sight with respect to the gunline become:

$$\begin{aligned} \dot{\Delta\theta}_{ET} = & -1/R \left\{ \cos\gamma_E \left[(V_{TX} + V_{TY}\Psi) \cos\theta - V_{TY} \sin\theta - V \right] \right. \\ & \left. - \sin\gamma_E \left[V_{TX} \cos\theta + (V_{TX} + V_{TY}\Psi) \sin\theta - V\alpha \right] \right\} \Delta\theta_{ET} \\ & - 1/R \left\{ \cos\gamma_E \left[(V_{TX} + V_{TY}\Psi) \cos\theta - V_{TZ} \sin\theta \right] - \sin\gamma_E \left[(V_{TX} + V_{TY}\Psi) \sin\theta \right. \right. \\ & \left. \left. + V_{TZ} \cos\theta \right] \right\} \Delta\theta + (V/R) \cos\gamma_E \Delta\alpha - \dot{\Delta\theta} \quad (C27) \end{aligned}$$

$$\begin{aligned} \dot{\Delta\theta}_{LT} = & -1/R \left\{ \cos\gamma_E \left[(V_{TX} + V_{TY}\Psi) \cos\theta - V_{TY} \sin\theta - V \right] \right. \\ & \left. - \sin\gamma_E \left[V_{TZ} \cos\theta + (V_{TX} + V_{TY}\Psi) \sin\theta - V\alpha \right] \right\} \Delta\theta_{LT} - (V/R) \Delta\beta - \sin\gamma_E \Delta_p \\ & + 1/R \left[V_{TZ} \cos\theta + (V_{TX} + V_{TY}\Psi) \sin\theta \right] \Delta\phi - \left[(\cos\gamma_E) (\Delta r) + \int V_{TX} (\Delta r) dt \right] \quad (C28) \end{aligned}$$

Since the velocity vectors of the target and attacking aircraft are approximately colinear, then range rate is defined as:

$$\dot{R} = V_T - V \quad (C29)$$

Referring to Figure 52 range rate of target aircraft along the gunline is:

$$\begin{aligned} \dot{R} = & \cos\gamma_E \left[(V_{TX} + V_{TY}\Psi) \cos\theta - V_{TZ} \sin\theta - V \right] - \sin\gamma_E \left[V_{TZ} \cos\theta \right. \\ & \left. + (V_{TX} + V_{TY}\Psi) \sin\theta - V\alpha \right] \quad (C30) \end{aligned}$$

and the target velocity's earth - axis component is

$$V_{TX} = (V + R) \cos\theta \cos\gamma_E \quad (C31)$$

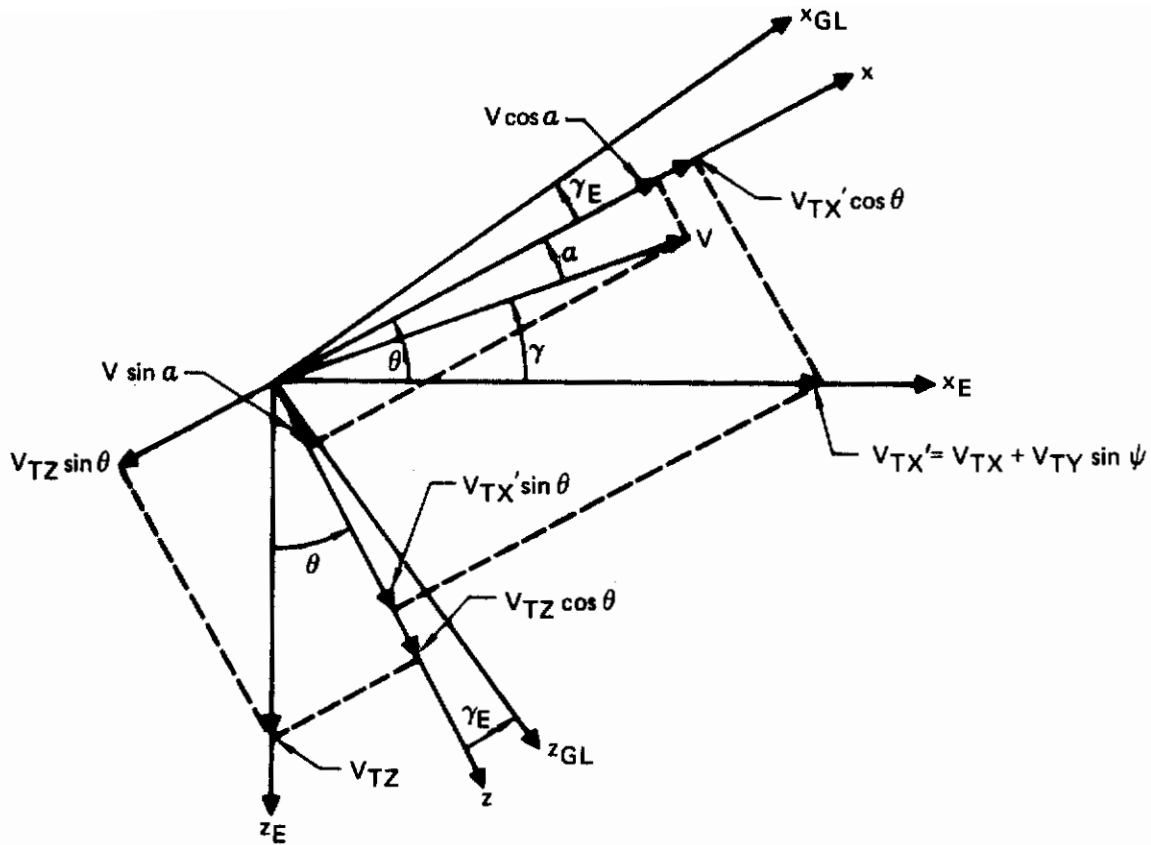

FIGURE 52
GEOMETRY OF THE RELATIVE VELOCITY VECTOR

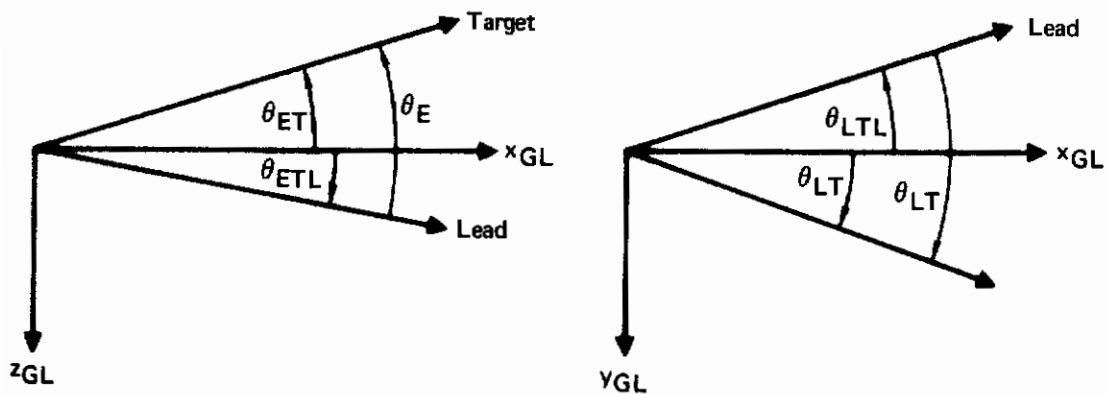

FIGURE 53
GEOMETRY OF THE ELEVATION AND LATERAL TRACKING ERRORS
WITH RESPECT TO THE GUNLINE

Contrails

Since the target velocity normal to the gunline is small, then

$$\left[V_{TZ} \cos \theta + (V_{TX} + V_{TY} \Psi) \sin \theta \right] \Delta \phi / R = 0 \quad (C32)$$

Substituting the expressions defined by Equations C29 through C30 in Equations C27 through C28 and applying Laplace transforms theory, the Laplace transform of the visual elevation and lateral tracking rates of the target with respect to the gunline are:

$$\Delta \theta_{ET}(\lambda) = - \frac{\lambda + (V \cos \gamma_E + \dot{R})/R}{\lambda + \dot{R}/R} \Delta \theta(\lambda) + \frac{V \cos \gamma_E / R}{\lambda + \dot{R}/R} \Delta \alpha(\lambda) \quad (C33)$$

$$\Delta \theta_{LT}(\lambda) = - \frac{V/R}{\lambda + \dot{R}/R} \Delta \beta(\lambda) - \frac{\sin \gamma_E}{\lambda + \dot{R}/R} \Delta \rho(\lambda) - \frac{(\cos \gamma_E) \lambda + (V + \dot{R})/R}{\lambda (\lambda + \dot{R}/R)} \Delta r(\lambda) \quad (C34)$$

The sign convention of the tracking errors between the line of sight of the target with respect to the gunline and the lead angle with respect to the gunline are illustrated by Figure 53. The tracking errors are defined as:

$$\theta_E = \Delta \theta_{ET} + \theta_{ETL} \quad (C35)$$

$$\theta_L = \Delta \theta_{LT} + \theta_{LTL} \quad (C36)$$

For the disturbed reticle lead computing optical sight system that is mechanized in the F-4E the elevation and lateral lead angle components are dynamically related to the aircraft's gunline rates and normal acceleration at the sight gyro location by:

$$\theta_{ETL}(\lambda) = \frac{T_N}{1 + (1 + \sigma) T_N \lambda} \left[\Delta \theta^*(\lambda) \cdot 0.005 n_z(\lambda) \right] \quad (C37)$$

$$\theta_{LTL}(\lambda) = \frac{T_N}{1 + (1 + \sigma) T_N \lambda} \left[\cos \gamma_E \Delta r(\lambda) + \sin \gamma_E \Delta \rho(\lambda) \right] \quad (C38)$$

where T_N is the sight sensitivity and σ is a stability constant. Incorporating the geometry and lead angle dynamics into Figure 47 the resulting linearized block diagrams of the elevation and lateral aerial fire control modes are illustrated by Figures 54 and 55. The specification of the aircraft's dynamics and of the pilot model depends on the aircraft to be studied.

For an aircraft tracking stationary ground targets the range rate defined by Equation C30 becomes:

$$\dot{R} = -V \quad (C39)$$

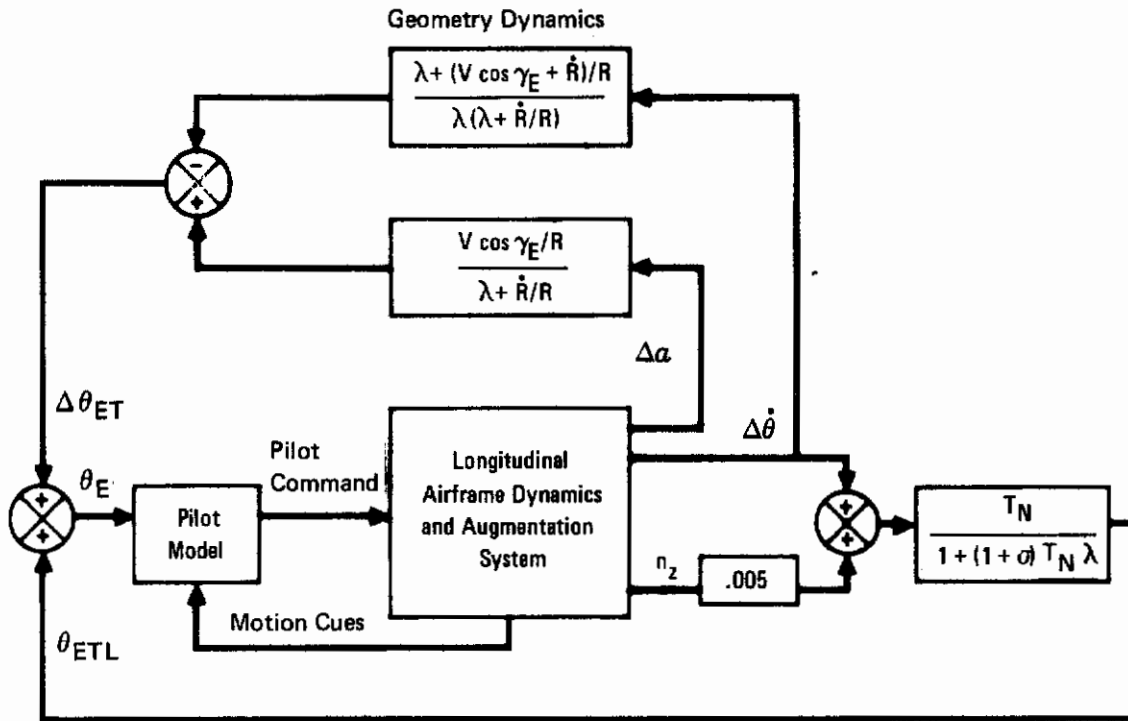

FIGURE 54
ELEVATION CHANNEL FOR TRACKING AERIAL TARGETS

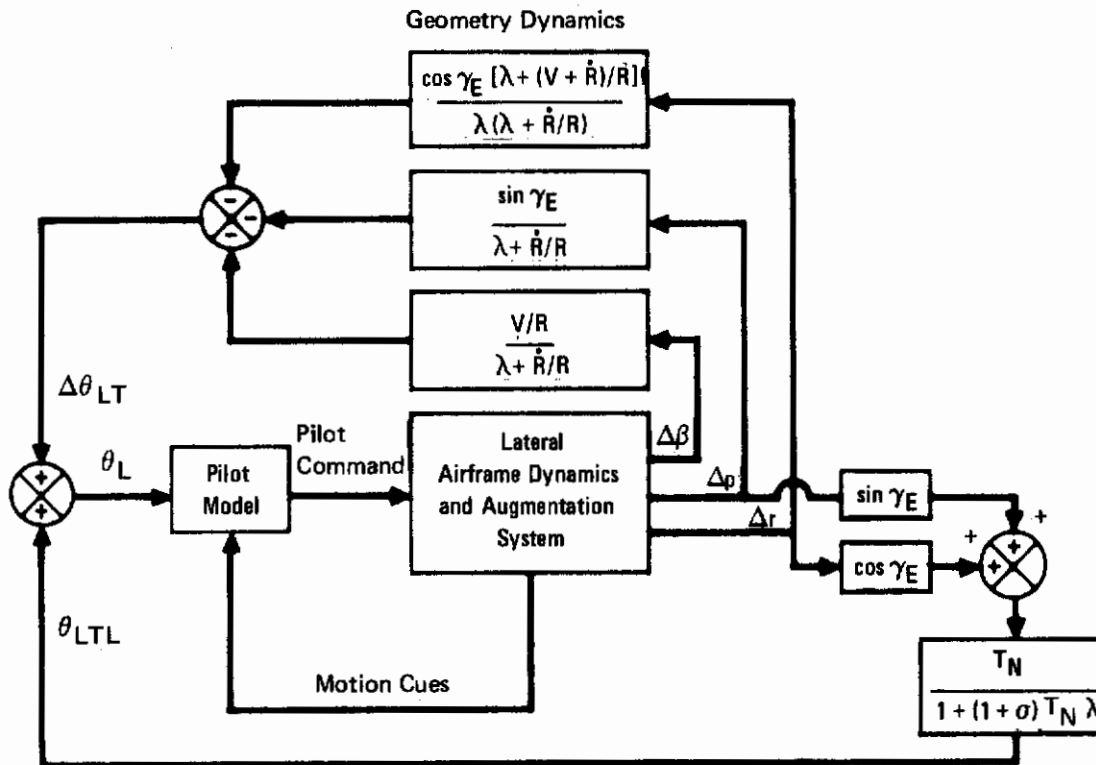

FIGURE 55
LATERAL DIRECTIONAL CHANNEL FOR TRACKING AERIAL TARGETS

Contrails

Substituting the range rate expression into the tracking rate equations described by Equations C33 through C34, the visual elevation and lateral tracking rates of a stationary ground target with respect to the gunline become:

$$\Delta\theta_{ET}(\lambda) = -\frac{-V(1-\cos\gamma_E)/R}{\lambda - V/R} \Delta\theta(\lambda) + \frac{\cos\gamma_E V/R}{S - V/R} \Delta\alpha(\lambda) \quad (C40)$$

$$\Delta\theta_{LT}(\lambda) = -\frac{V/r}{\lambda - V/R} \Delta\beta(\lambda) - \frac{\sin\gamma_E}{\lambda - V/R} \Delta p(\lambda) - \frac{\cos\gamma_E}{\lambda - V/R} \Delta r(\lambda) \quad (C41)$$

The block diagrams for tracking ground targets are illustrated in Figures 54 and 55.

If the roll and yaw rate airframe transfer functions are defined in a stability axis coordinate system, an appropriate transformation must be made in order to define the roll and yaw rates in the body axis coordinates. The block diagrams in Figures 56 and 57 assume that the roll and yaw rates are defined in the body axis coordinate system.

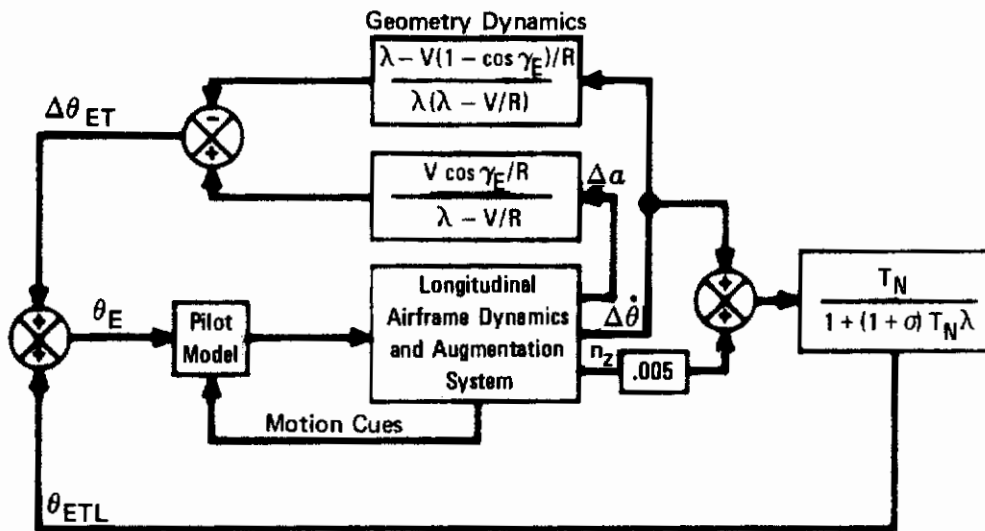

FIGURE 56
ELEVATION CHANNEL FOR TRACKING STATIONARY GROUND TARGETS

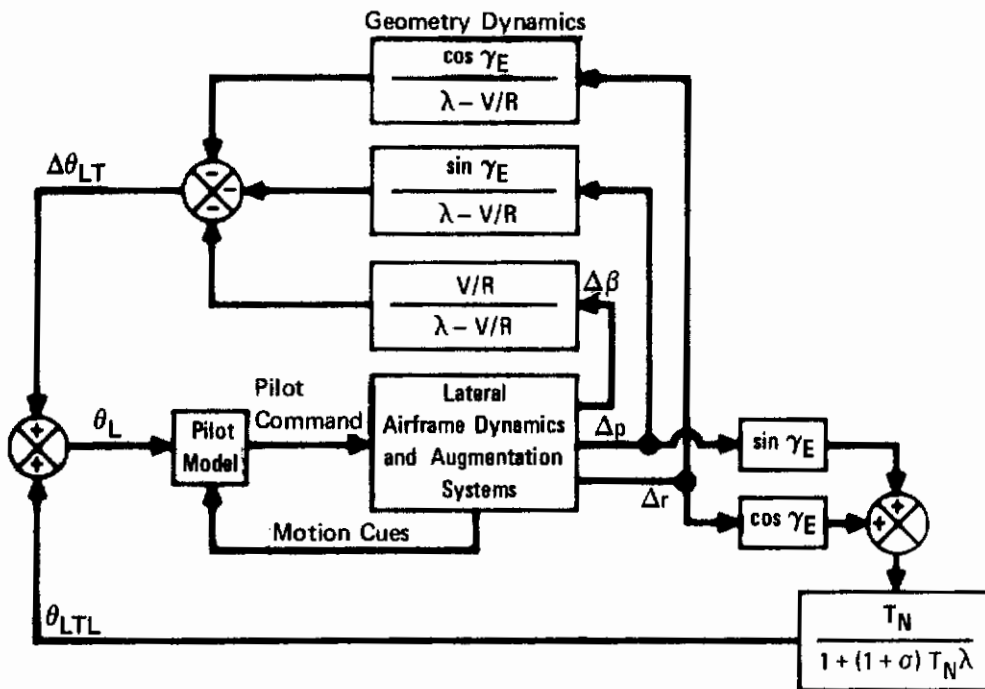

FIGURE 57
LATERAL DIRECTIONAL CHANNEL FOR TRACKING STATIONARY GROUND TARGETS

Contrails

APPENDIX IV

HYBRID SIMULATION SOFTWARE

The equations-of-motion and physical data used to simulate the aircraft are described in this appendix.

The airframe mechanized for the simulation was a twin engine, 38,732 lbs, high performance fighter aircraft. The entire flight envelope was utilized during the simulation program. The altitude ranged from sea level to 60,000 feet. The physical data used are shown in Table XII.

A set of nonlinear large perturbation six degree of freedom differential equations of motion was used to describe the airframe. The three force equations (\dot{u} , \dot{v} , \dot{w}) were derived based upon the wind axis system while the moment equations (\dot{p} , \dot{q} , \dot{r}) were based upon a body (waterline aligned) axis system. Additional equations were needed to describe the atmospheric properties, body acceleration, Euler body rates and geographic frame velocity equations. A direction cosine matrix was used to calculate geographic frame velocities in terms of wind axis velocities. The entire set of equations mechanized to describe the simulated aircraft is presented as follows:

o Six Degree-of-Freedom Differential Equations

$$\dot{u} = vr - wq - g \sin \theta - \frac{\bar{q}S}{m} C_D + .9958 \frac{T}{m}$$

$$\dot{v} = wp - ur + g \sin \phi \cos \theta + \frac{\bar{q}S}{m} \left[\frac{b}{2V} (C_{Y_p} p + C_{Y_r} r) + C_{Y_\beta} \beta + C_{Y_{\delta a}} \delta a + C_{Y_{\delta_{SP}}} \delta_{SP} + C_{Y_{\delta_R}} \delta_R \right]$$

$$\dot{w} = uq - vp + g \cos \phi \cos \theta - \frac{\bar{q}S}{m} C_L - .0915 \frac{T}{m}$$

$$\dot{p} = \frac{1}{(I_X I_Z - I_{XZ}^2)} \left\{ I_{XZ} (I_X - I_Z) pq - (I_Z^2 + I_{XZ}^2 - I_Y I_Z) qr + \bar{q} S b I_Z \left[\frac{b}{2V} (C_{l_p} p + C_{l_r} r) + C_{l_\beta} \beta + C_{l_{\delta a}} \delta a + C_{l_{\delta_{SP}}} \delta_{SP} + C_{l_{\delta_R}} \delta_R \right] + \bar{q} S b I_X \left[\frac{b}{2V} (C_{n_p} p + C_{n_r} r) + C_{n_\beta} \beta + C_{n_{\delta a}} \delta a + C_{n_{\delta_{SP}}} \delta_{SP} + C_{n_{\delta_R}} \delta_R \right] \right\}$$

$$\dot{q} = \frac{I_Z - I_X}{I_Y} pr + \frac{I_{XZ}}{I_Y} (r^2 - p^2) + \frac{\bar{q} S \bar{c}}{I_Y} \left[C_M + \frac{\bar{c}}{2V} (C_{m_\alpha} \alpha + C_{m_q} q) + C_{m_{\delta_S}} \delta_S \right] + \frac{T}{I_Y} \left[.9958 \left(\frac{c.g. \cdot w l}{12} - 2.7 \right) + .0915 \left(\frac{\%c.g. \cdot \bar{c}}{100} - 4.361 \right) \right]$$

TABLE XII
AIRCRAFT PHYSICAL DATA

Variable Symbol	Variable Name	Value	Units
W	Gross Weight	38,732	Lb
I_x	Moment of Inertia around X Axis	24,873	Slug-ft ²
I_y	Moment of Inertia around Y Axis	152,495	Slug-ft ²
I_z	Moment of Inertia around Z Axis	169,824	Slug-ft ²
I_{xz}	Cross Product Moment of Inertia around X-Z Axis	4,820	Slug-ft ²
S	Wing Area	530	Ft ²
b	Wing Span	38.408	Ft
\bar{c}	Mean Aerodynamic Chord Length	16.042	Ft
cg	Center of Gravity	28.3% \bar{c}	Ft

Contrails

$$\dot{r} = \frac{I_X - I_Y}{I_Z} pq + \frac{I_X}{I_Z} (\dot{p} - qr) + \frac{\bar{q}Sb}{I_Z} \left[\frac{b}{2V} (C_{n_p p} + C_{n_r r}) + C_{n_\beta \beta} + C_{n_{\delta_a} \delta_a} \right. \\ \left. + C_{n_{\delta_{SP}} \delta_{SP}} + C_{n_{\delta_R} \delta_R} \right]$$

$$V = (u^2 + v^2 + w^2)^{1/2}$$

$$\alpha = \tan^{-1} \left(\frac{w}{u} \right)$$

$$\beta = \sin^{-1} \left(\frac{v}{V} \right)$$

o Atmospheric Properties Equations

$$M = \frac{V}{1117.1 - .00412778h} \quad h \leq 36000 \text{ ft}$$

$$M = \frac{V}{968.5} \quad h > 36000 \text{ ft}$$

$$\rho = 2(.034475 + .019213 \times 10^{-10} h^2 - .050381 \times 10^{-5} h)^2 \quad h \leq 36000 \text{ ft}$$

$$\rho = 2(.039708 + .039227 \times 10^{-10} h^2 - .072121 \times 10^{-5} h)^2 \quad h > 36000 \text{ ft}$$

$$\bar{q} = 1/2 \rho V^2$$

$$V_{CAL} = 12.127 \rho V \quad M \leq 0.6$$

$$V_{CAL} = 60M - 36 + V_{CAL} \quad M > 0.6$$

o Acceleration Equations

$$a_{x_{cg}} = -\sin\theta - \frac{\bar{q}S}{mg} C_D + .9958 \frac{T}{mg}$$

$$a_{y_{cg}} = \frac{\bar{q}S}{mg} \left[\frac{b}{2V} (C_{y_p p} + C_{y_r r}) + C_{y_\beta \beta} + C_{y_{\delta_a} \delta_a} + C_{y_{\delta_{SP}} \delta_{SP}} + C_{y_{\delta_R} \delta_R} \right]$$

$$a_{z_{cg}} = -\cos\phi \cos\theta + \frac{\bar{q}S}{mg} C_L + .0915 \frac{T}{mg}$$

$$a_{x_{cc}} = a_{x_{cg}} + \sin\theta - \frac{12.033}{g} (q^2 + r^2)$$

$$a_{y_{cc}} = a_{y_{cg}} + \frac{20.95}{g} (\dot{r} + pq) - \frac{1.705}{g} (\dot{p} - rq)$$

$$a_{z_{cc}} = a_{z_{cg}} + \frac{12.033}{g} (\dot{q} - pr)$$

Contrails

$$a_{Y_p} = a_{Y_{cg}} + \frac{16.3}{g} (\dot{r} + pq)\cos(\alpha + .014) + (\dot{p} - rq)\sin(\alpha + .014)$$

$$a_{Z_p} = a_{Z_{cg}} + \frac{12.033}{g} (\dot{q} - pr)$$

$$N_{LF} = a_{Z_p} + \cos \phi \cos \theta$$

o Euler Body Rate Equations

$$\dot{\psi} = (q \sin \phi + r \cos \phi) / \cos \theta$$

$$\dot{\theta} = q \cos \phi - r \sin \phi$$

$$\dot{\phi} = p + \dot{\psi} \sin \theta$$

o Geographic Frame Velocity Equations

$$\begin{bmatrix} V_N \\ V_E \\ \dot{h} \end{bmatrix} = \begin{bmatrix} \cos \theta \cos \psi & \cos \theta \sin \psi & -\sin \theta \\ \sin \phi \sin \theta \cos \psi & -\cos \phi \sin \psi & \sin \phi \sin \theta \sin \psi + \cos \phi \cos \psi \\ \cos \phi \sin \theta \cos \psi & +\sin \phi \sin \psi & \cos \phi \sin \theta \sin \psi - \sin \phi \cos \psi \end{bmatrix} \begin{bmatrix} u \\ v \\ w \end{bmatrix}^T$$

APPENDIX V

HYBRID COMPUTER DATA OUTPUT

Pilot performance was evaluated with three independent data sources consisting of digital printouts, analog strip charts and audio tape recordings. The digital data were obtained only during the scoring intervals whereas the analog strip chart data were plotted continuously throughout each test run. This Appendix presents examples of digital printouts and analog strip chart plots and Appendix VII documents pilot comments associated with each test configuration.

1. DIGITAL PRINTOUT DATA

The histograms and cumulative distribution plots were generated in digital form with pilot effort indexes and figure-of-merit values printed on the same page. For the first scored mission phase, the LAHS, the digital printout in Figure 58 shows two parameters and in the remaining four scored phases, four mission parameters are presented in the sample output, Figures 59 through 62. The type of mission flown, mission phase, configuration, and pilot number are also identified on each page.

The ordinate of the histogram and of the cumulative distribution plots represents the value of the function in percent scale and the abscissa shows the number of bins ranging from 1 through 21 with the corresponding dimensional limits on top of the page. In a few cases the accumulated histogram values reached the maximum printout limit of 40 percent. When this happens, the apparent printout maximum does not reflect the true value of the histogram parameter which must be computed by subtracting the difference in cumulative distribution across the bin in question. For example, bin number 10 on the right side of Figure 58 reaches the limit (40 percent) on the ordinate scale. The plot shows that the cumulative distribution function across this bin increases from 17.5 to 60 percent, therefore the actual histogram value for bin 10 is 42.5 percent. See Section VI for scoring information.

2. STRIP CHART RECORDS

Eight channels of continuous time histories were plotted on each of three Brush recorders. In addition, two recorders were wired to accept discrete ON-OFF signals.

A sample set of strip chart records, showing the time histories for the five scoring intervals of one simulation run, is presented in Figures 63 through 65. The sample strip chart plots shown correspond to the sample digital printouts described above.

Standard recording techniques were employed with one continuous signal plotted on each channel, except in the case of longitudinal and lateral pilot effort parameters where two parameters are plotted on the same channel. The sign of these two parameters is always positive since they

MISSION: A/G + A/A
 PHASE (MODE): LAHS

CONFIGURATION: 1,01
 PILOT: 4

LONG TUDINAL PILOT EFFORT INDEX: 36.14
 LATERAL PILOT EFFORT INDEX: 23.40

PITCH ERROR NEEDLE

FIGURE OF MERIT: 74.45

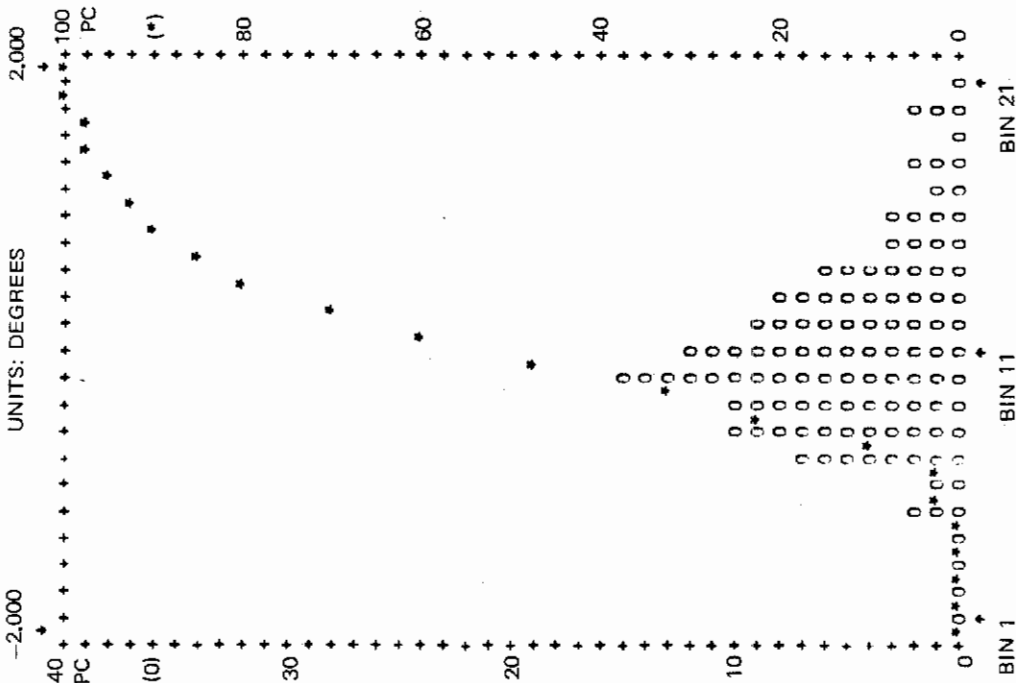

ROLL ERROR NEEDLE

FIGURE OF MERIT: 85.37

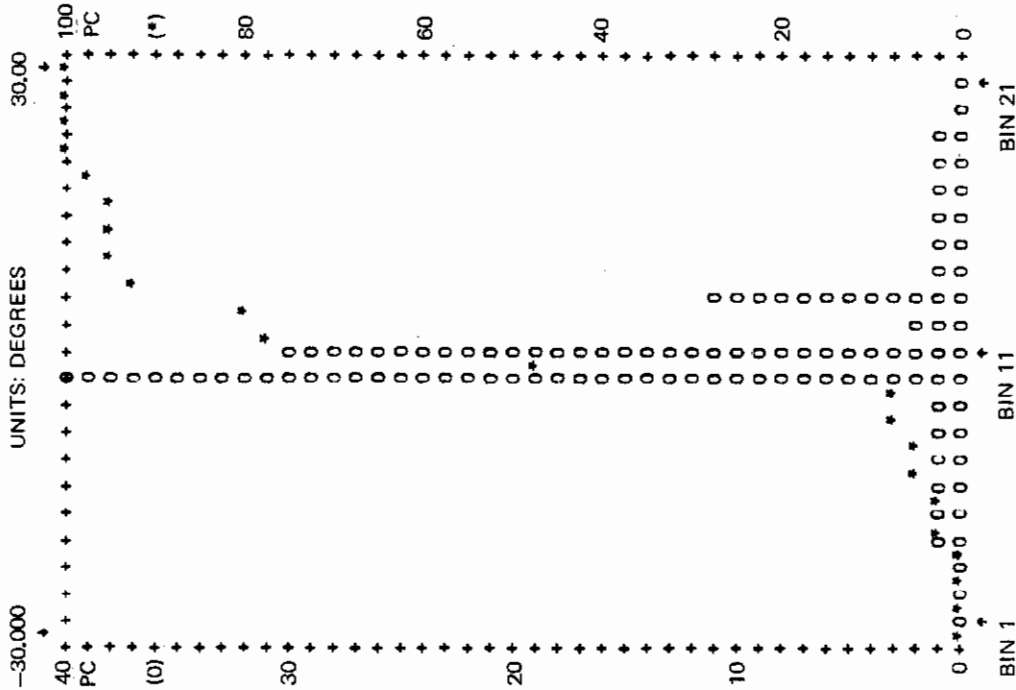

FIGURE 58 HISTOGRAM (O) AND CUMULATIVE DISTRIBUTION (*) PLOTS FOR LAHS

MISSION: A/G + A/A
PHASE (MODE): WD
ELEVATION ANGLAR ERROR

CONFIGURATION: 1.01
PILOT: 4
LONGI TUDINAL PILOT EFFORT INDEX: 72.94
LATERAL PILOT EFFORT INDEX: 35.51

AZIMUTH ANGLAR ERROR

FIGURE OF MERIT: 75.99

FIGURE OF MERIT: 92.26

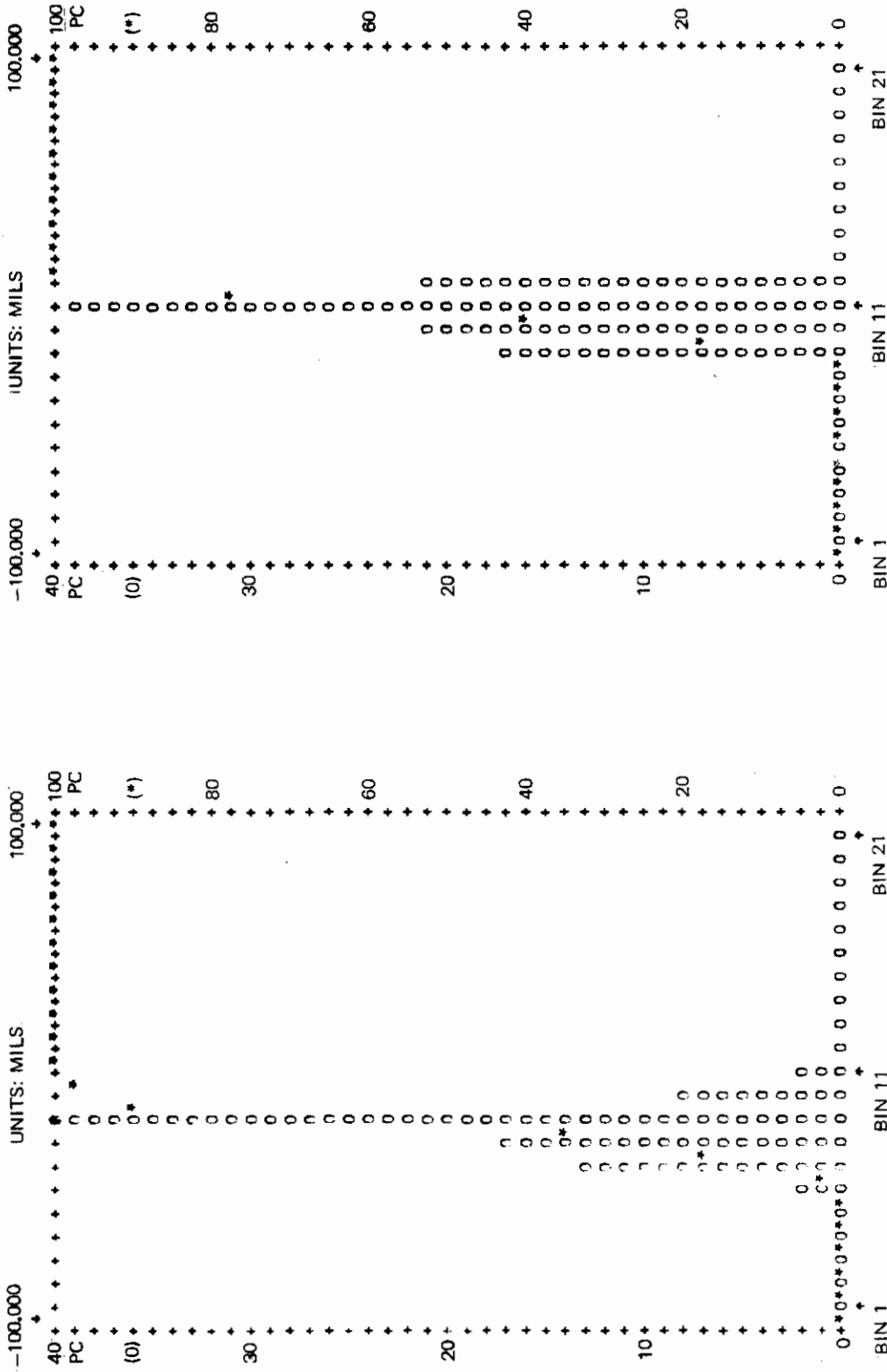

FIGURE 59 HISTOGRAM (O) AND CUMULATIVE DISTRIBUTION (*) PLOTS FOR WD

MISSION: A/G + A/A
 PHASE (MODE): WD
 CONFIGURATION: 1.01
 PILOT: 4
 LONG TUDINAL PILOT EFFORT INDEX: 72.94
 LATERAL PILOT EFFORT INDEX: 36.51

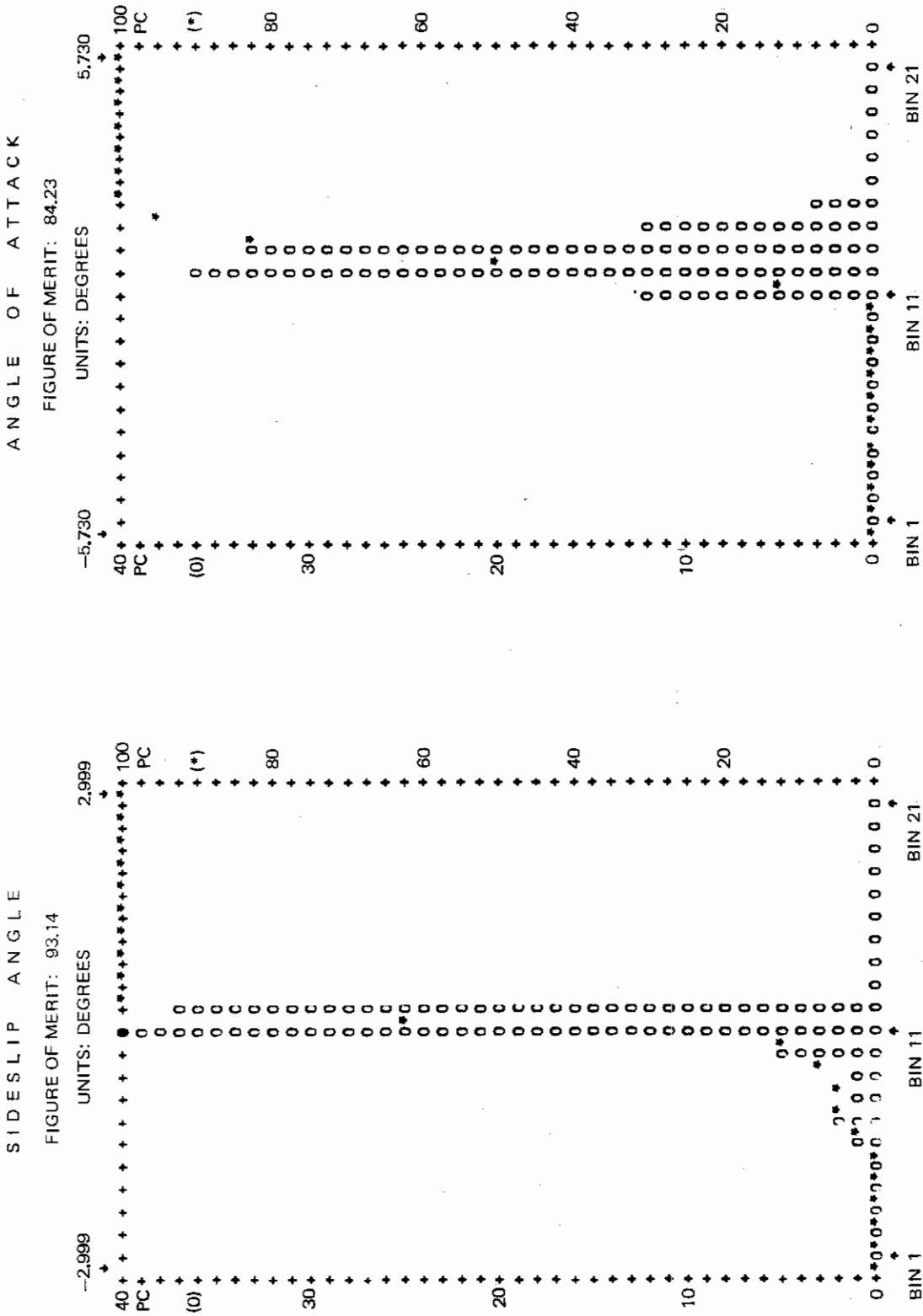
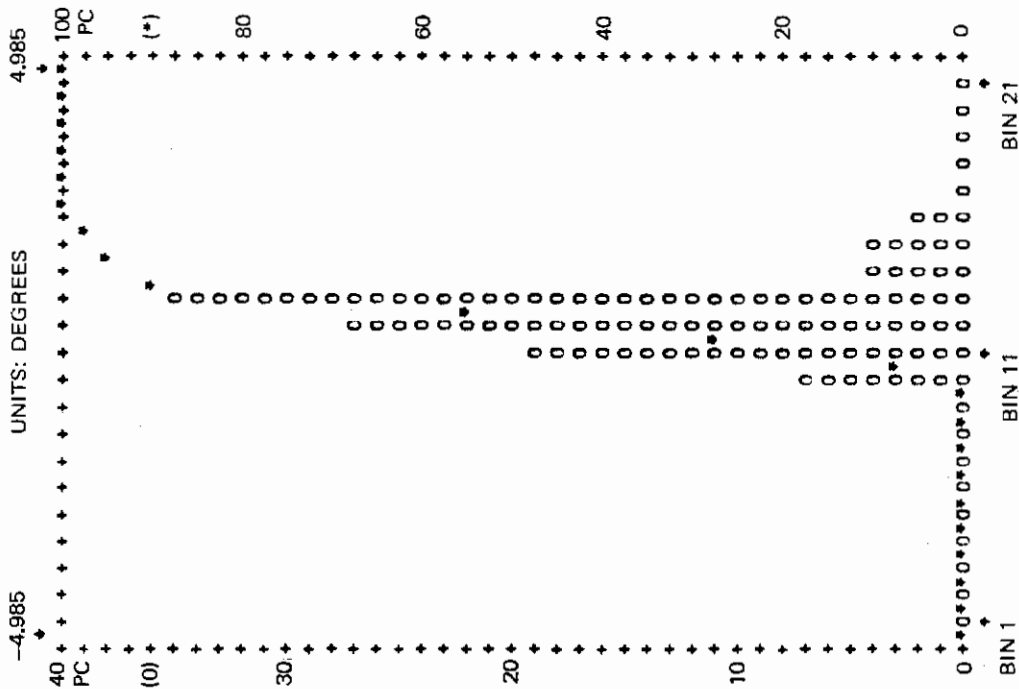

FIGURE 59 HISTOGRAM (O) AND CUMULATIVE DISTRIBUTION (*) PLOTS FOR WD (CONCLUDED)

MISSION: A/G + A/A
 PHASE (MODE): RECON
 CONFIGURATION: 1.01
 PILOT: 4
 LONGITUDINAL PILOT EFFORT INDEX: 61.29
 LATERAL PILOT EFFORT INDEX: .63

PITCH ANGLE

FIGURE OF MERIT: 85.50



MISSION: A/G + A/A
 PHASE (MODE): RECON
 CONFIGURATIONS: 1.01
 PILOT: 4
 LONGITUDINAL PILOT EFFORT INDEX: 61.29
 LATERAL PILOT EFFORT INDEX: .63

YAW ANGLE

FIGURE OF MERIT: 83.97

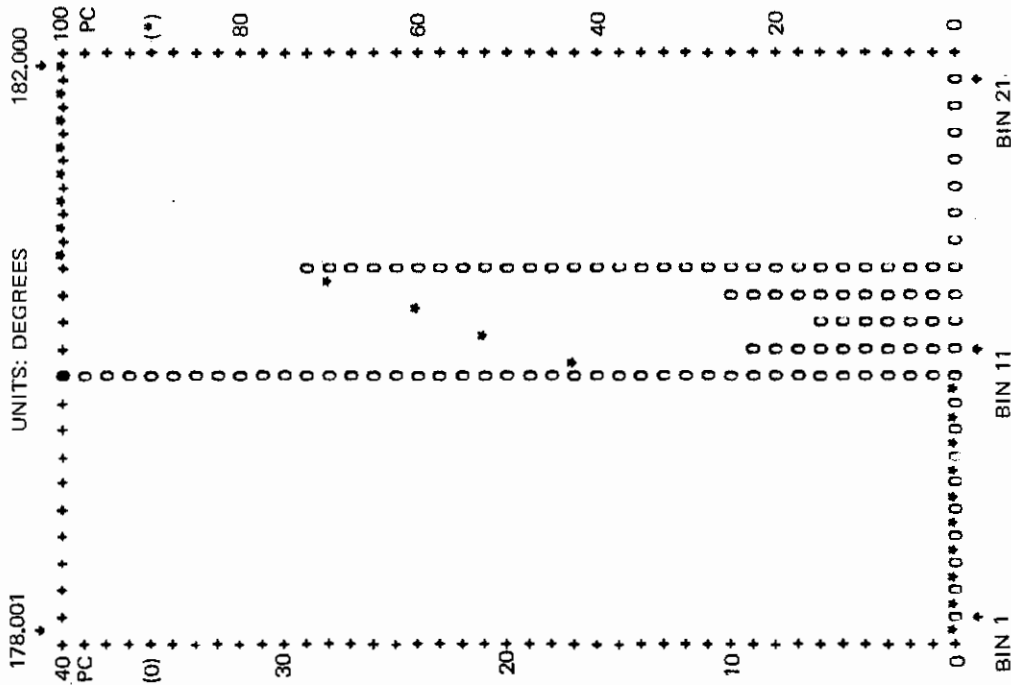

ALTITUDE

FIGURE OF MERIT: 91.72

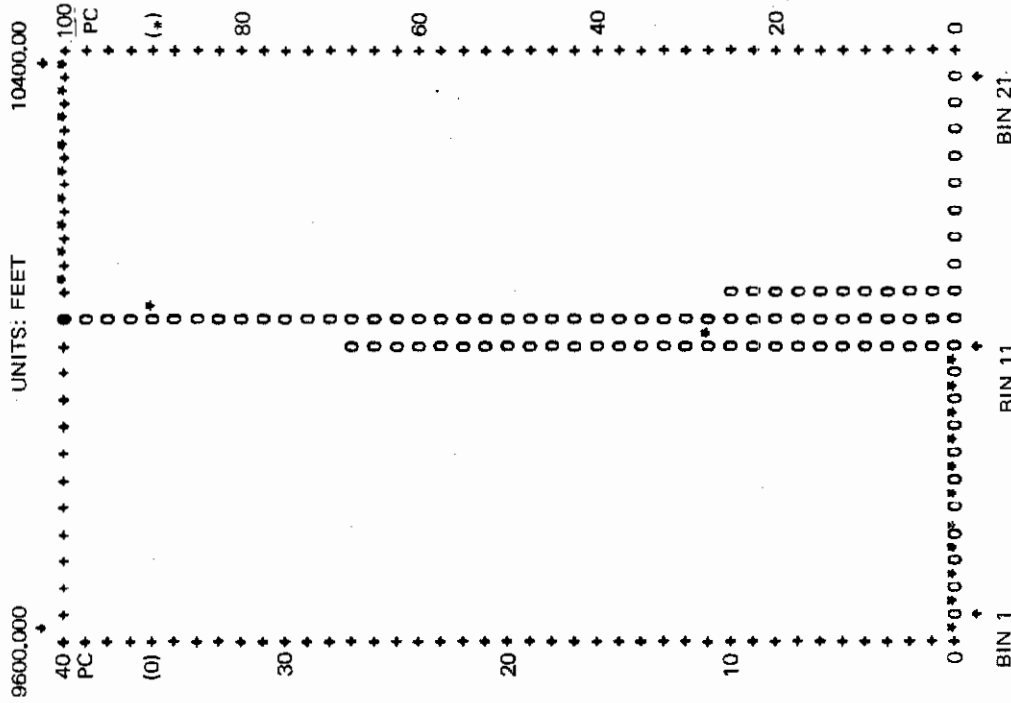

FIGURE 60
 HISTOGRAM (O) AND CUMULATIVE DISTRIBUTION (*) PLOTS FOR RECON (CONCLUDED)

MISSION: 1/6 + 4/A
PHASE (MODE): GA

CONFIGURATIONS: 1.01
PILOT: 4

LONGITUDINAL PILOT EFFORT INDEX: 141.81
LATERAL PILOT EFFORT INDEX: 87.96

ELEVATION ANGULAR ERROR

AZIMUTH ANGULAR ERROR

FIGURE OF MERIT: 91.78

FIGURE OF MERIT: 95.33

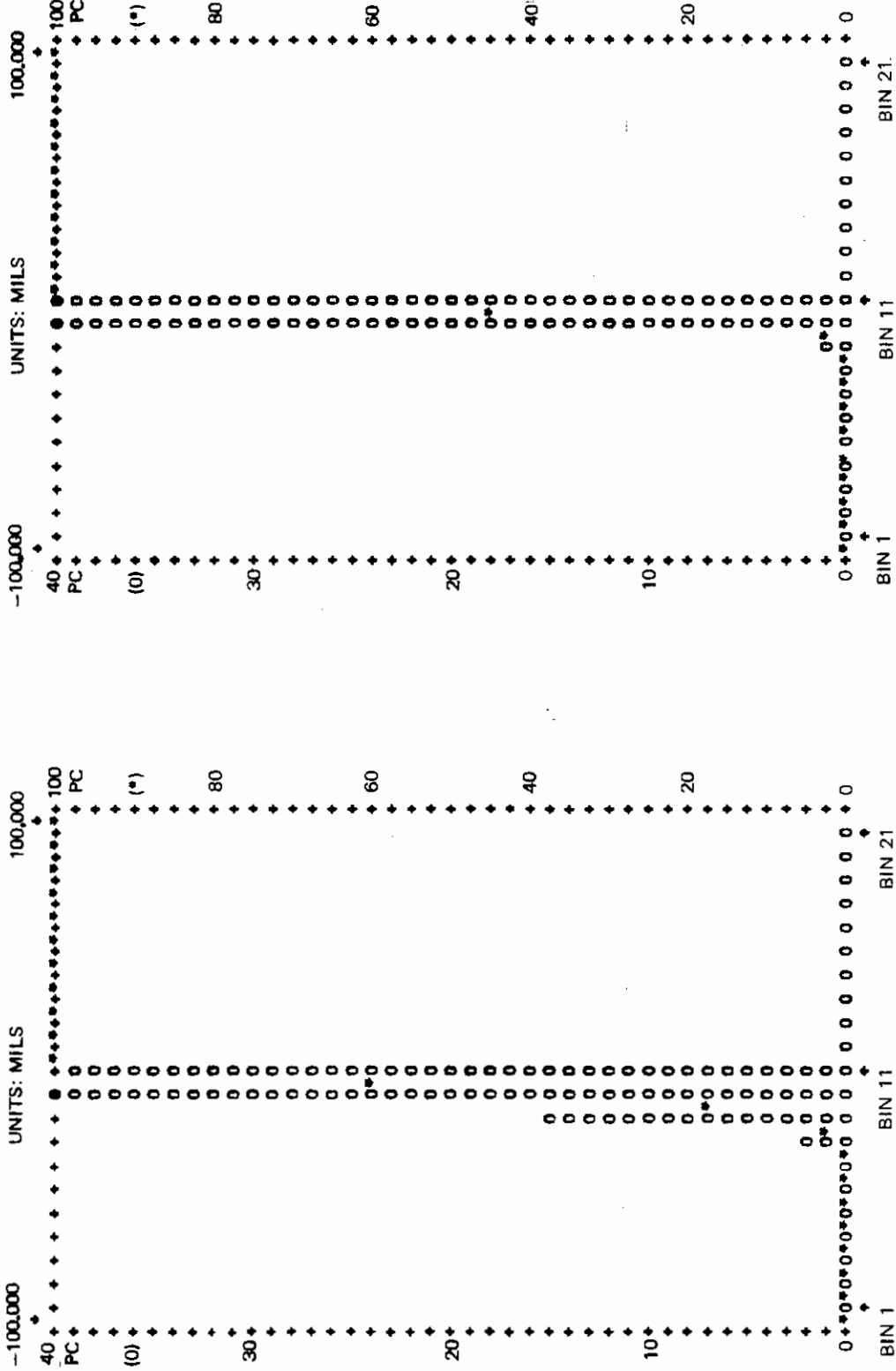

FIGURE 61
HISTOGRAM (O) AND CUMULATIVE DISTRIBUTION (*) PLOTS FOR GA

MISSION: A/G + A/A
 PHASE (MODE): GA

LONGITUDINAL PILOT EFFORT INDEX: 141.81
 LATERAL PILOT EFFORT INDEX: 87.96

CONFIGURATION: 1.01
 PILOTS: 4

TOTAL ANGULAR ERROR

FIGURE OF MERIT: 95.01

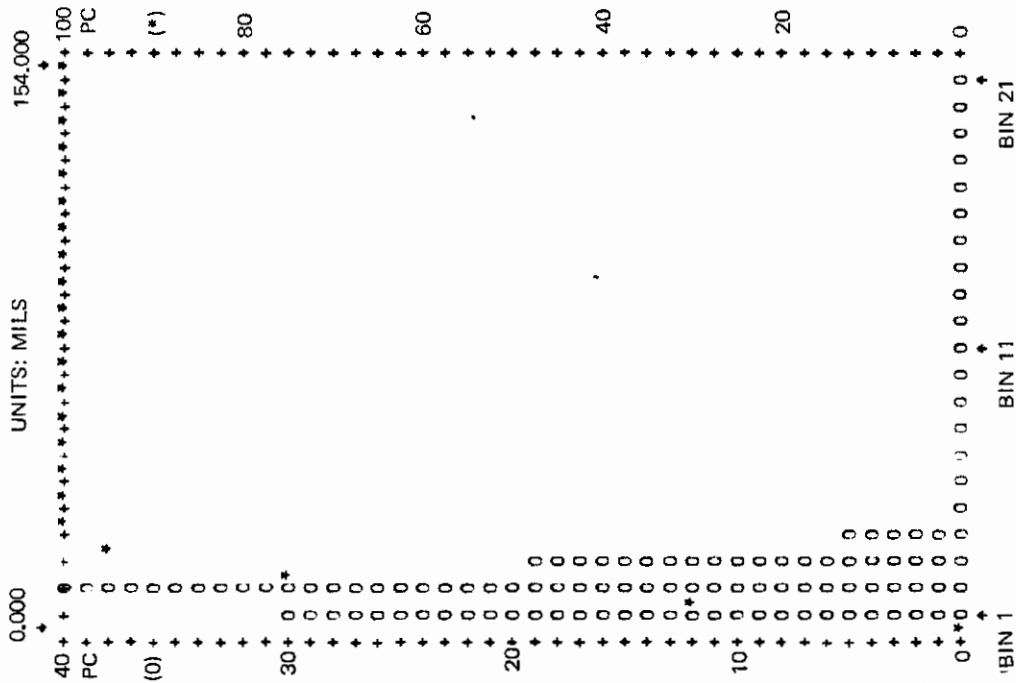

SIDESLIP ANGLE

FIGURE OF MERIT: 96.29

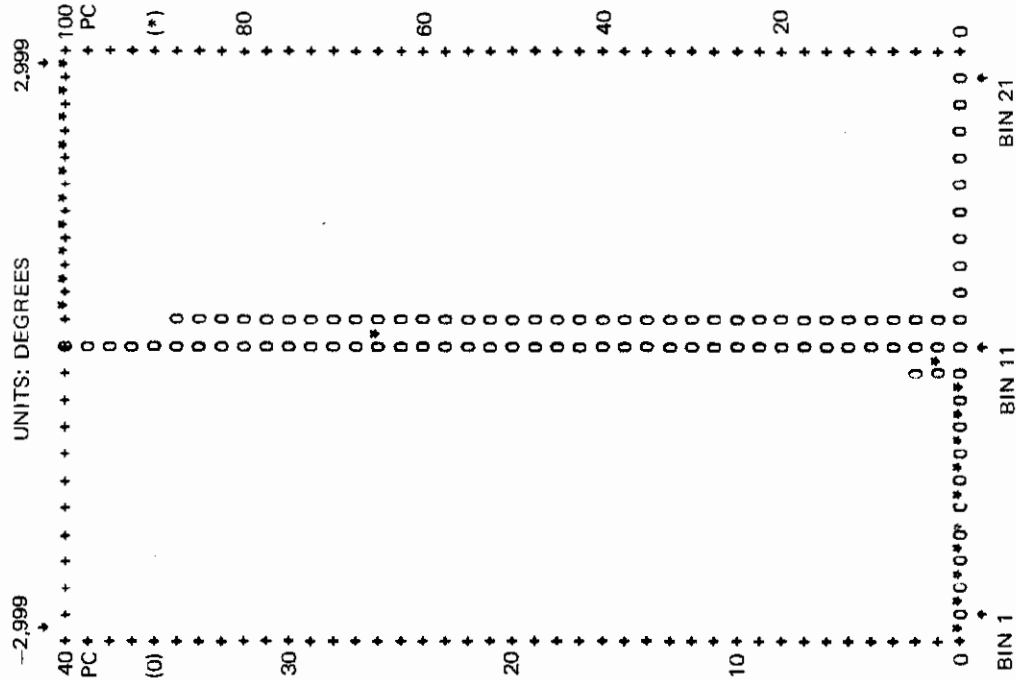

FIGURE 61
 HISTOGRAM (O) AND CUMULATIVE DISTRIBUTION (*) PLOTS FOR GA (CONCLUDED)

MISSION: 1/G + A/A
 PHASE (MODE): CO

CONFIGURATION: 1.01
 PILOT: 4

LONG: 1189.73
 LATERAL: 382.05

ELEVATION ANGLAR ERROR

AZIMUTH ANGLAR ERROR

FIGURE OF MERIT: 32.18

FIGURE OF MERIT: 72.12

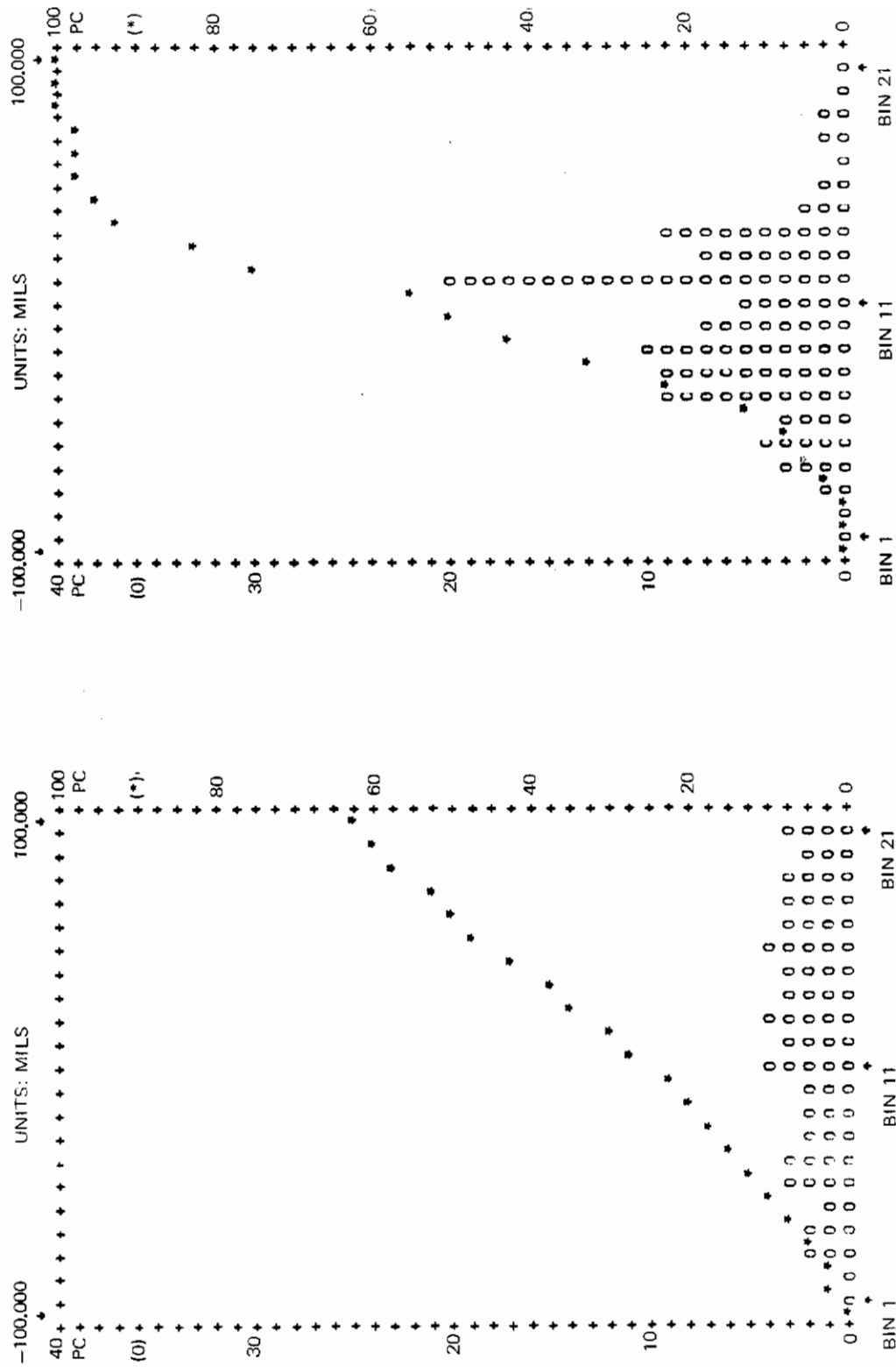

FIGURE 62
 HISTOGRAM (O) AND CUMULATIVE DISTRIBUTION (*) PLOTS FOR CO

MISSION: A/G + A/A
 PHASE (MODE): CO
 CONFIGURATION: 1.01
 PILOT: 4
 LONG TUDINAL PILOT EFFORT INDEX: 1189.73
 LATERAL PILOT EFFORT INDEX: 382.05

RANGE
 FIGURE OF MERIT: 84.42

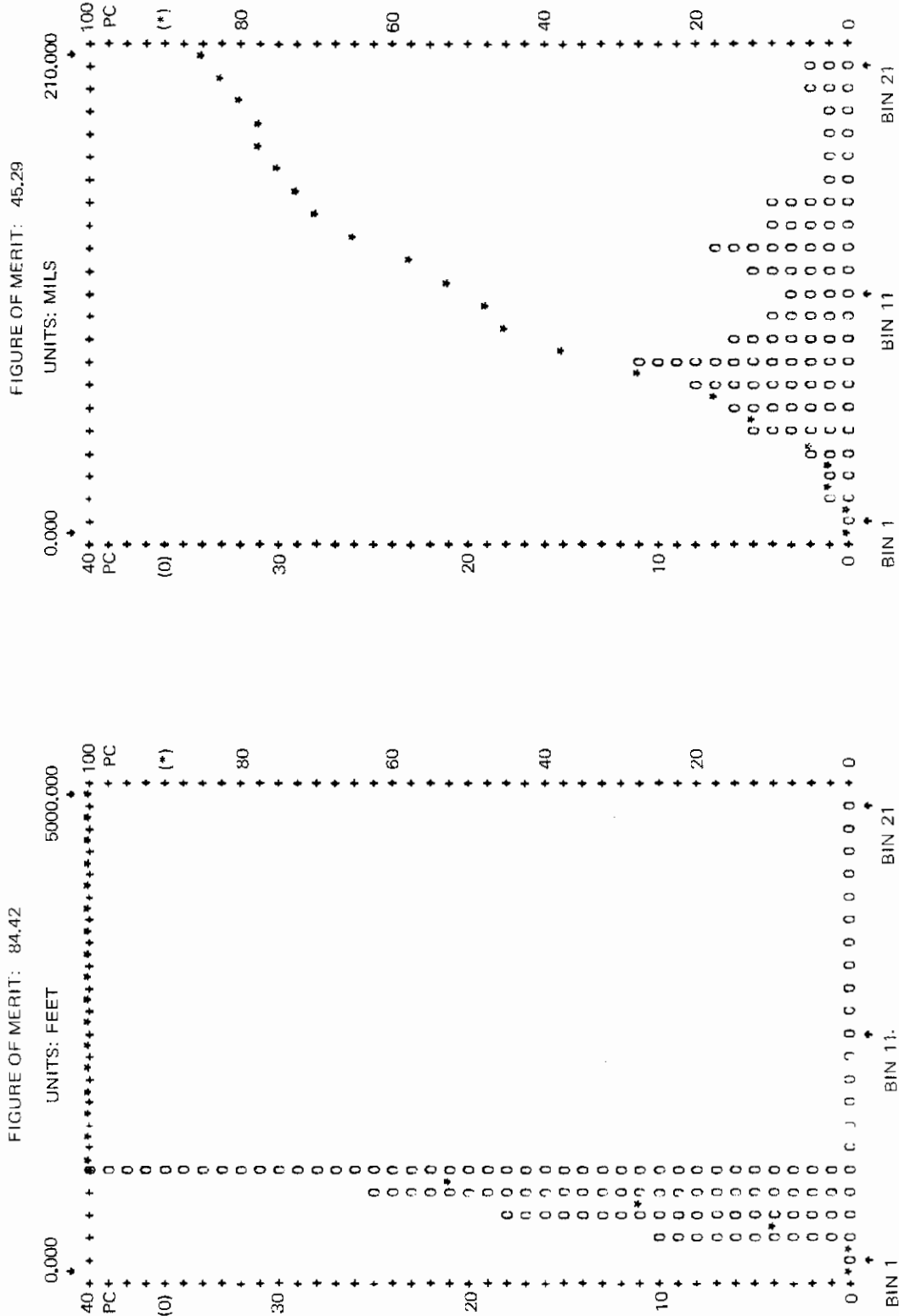

FIGURE 62
 HISTOGRAM (O) AND CUMULATIVE DISTRIBUTION (*) PLOTS FOR CO (CONCLUDED)

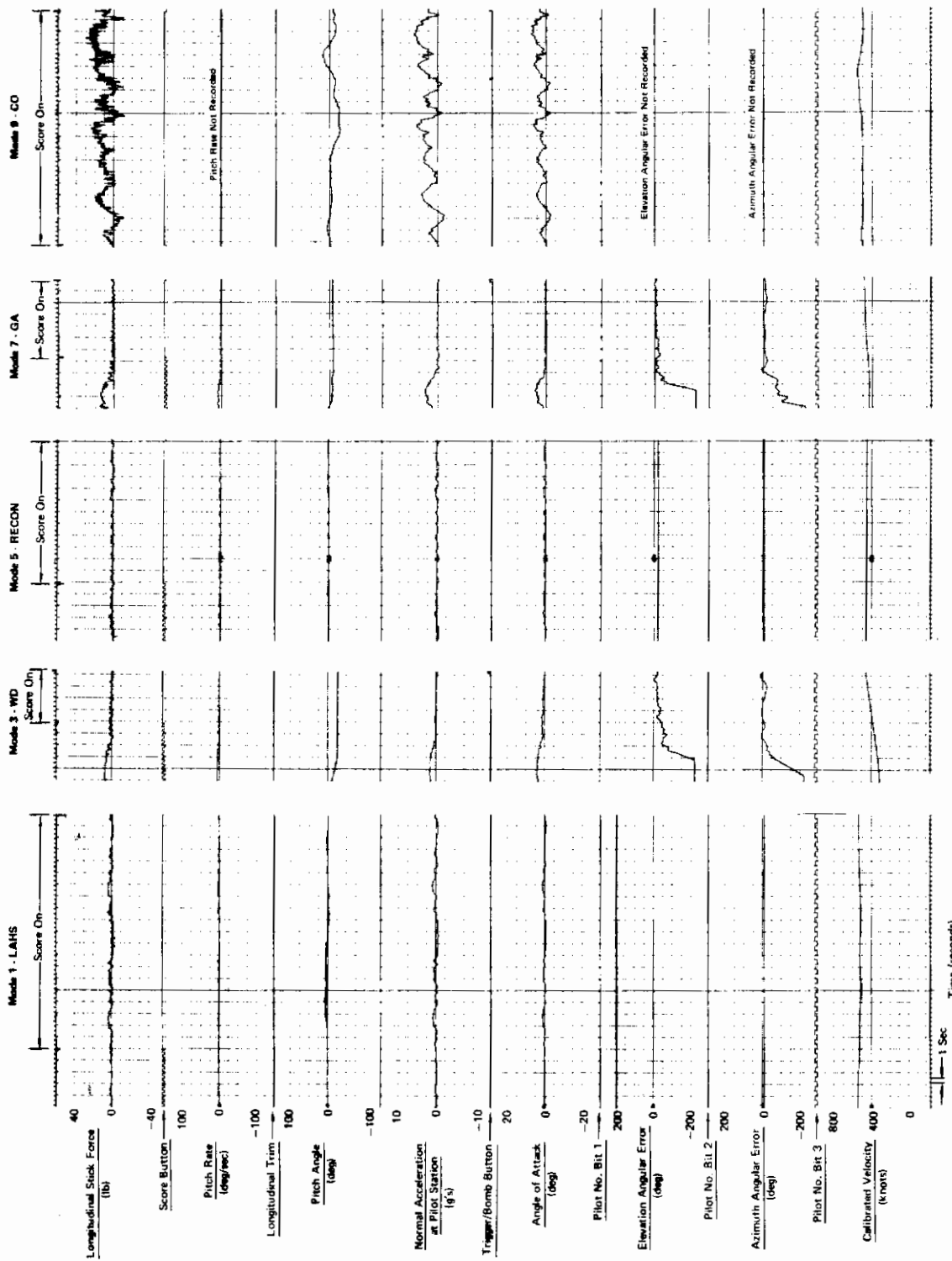

FIGURE 63
TIME HISTORY RESPONSE DATA FOR LAHS, WD, RECON, GA, AND
CO MODES OF OPERATION (RECORDER 1)

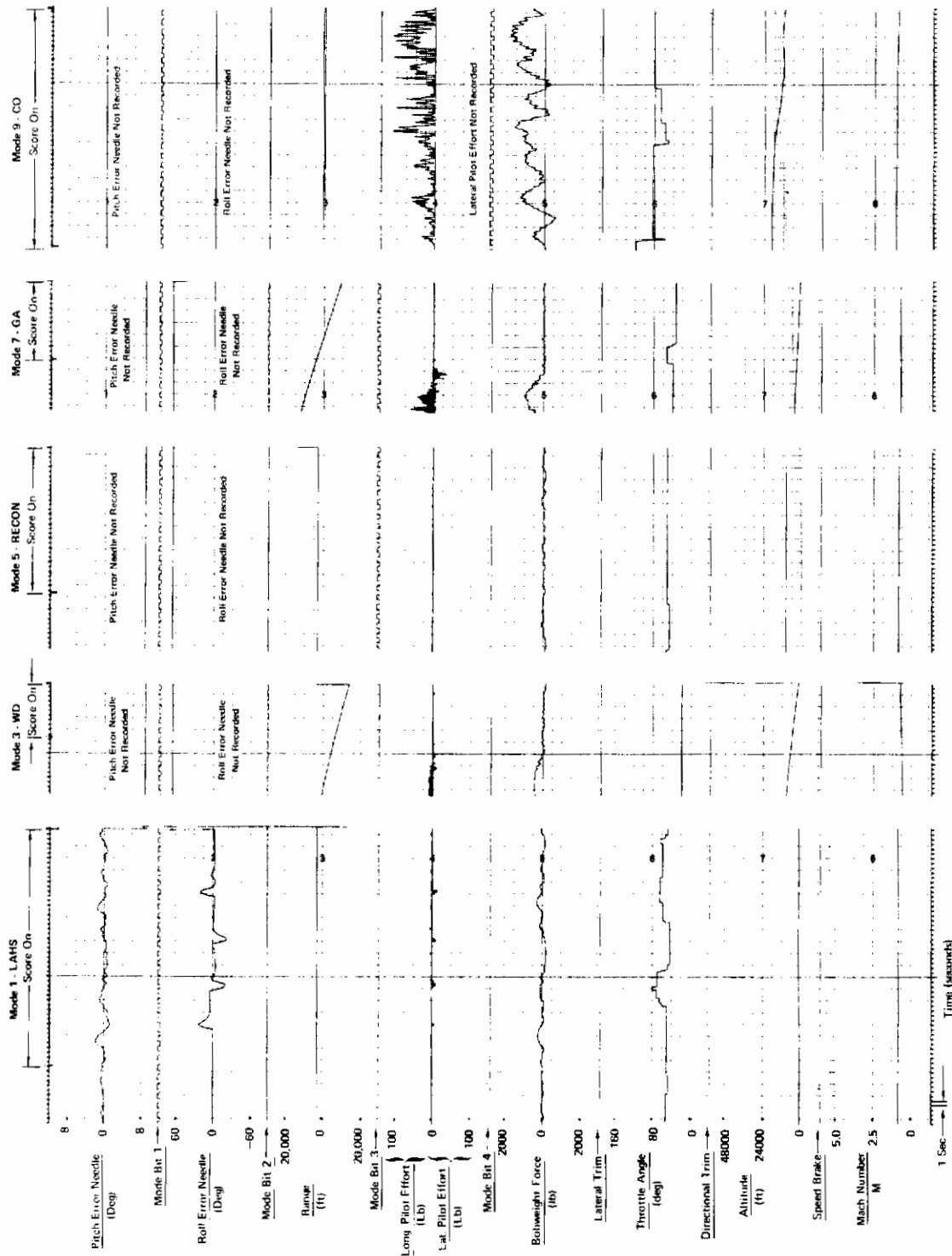

FIGURE 64
TIME HISTORY RESPONSE DATA FOR LAHS, WD, RECON, GA, AND
CO MODES OF OPERATION (RECORDER 2)

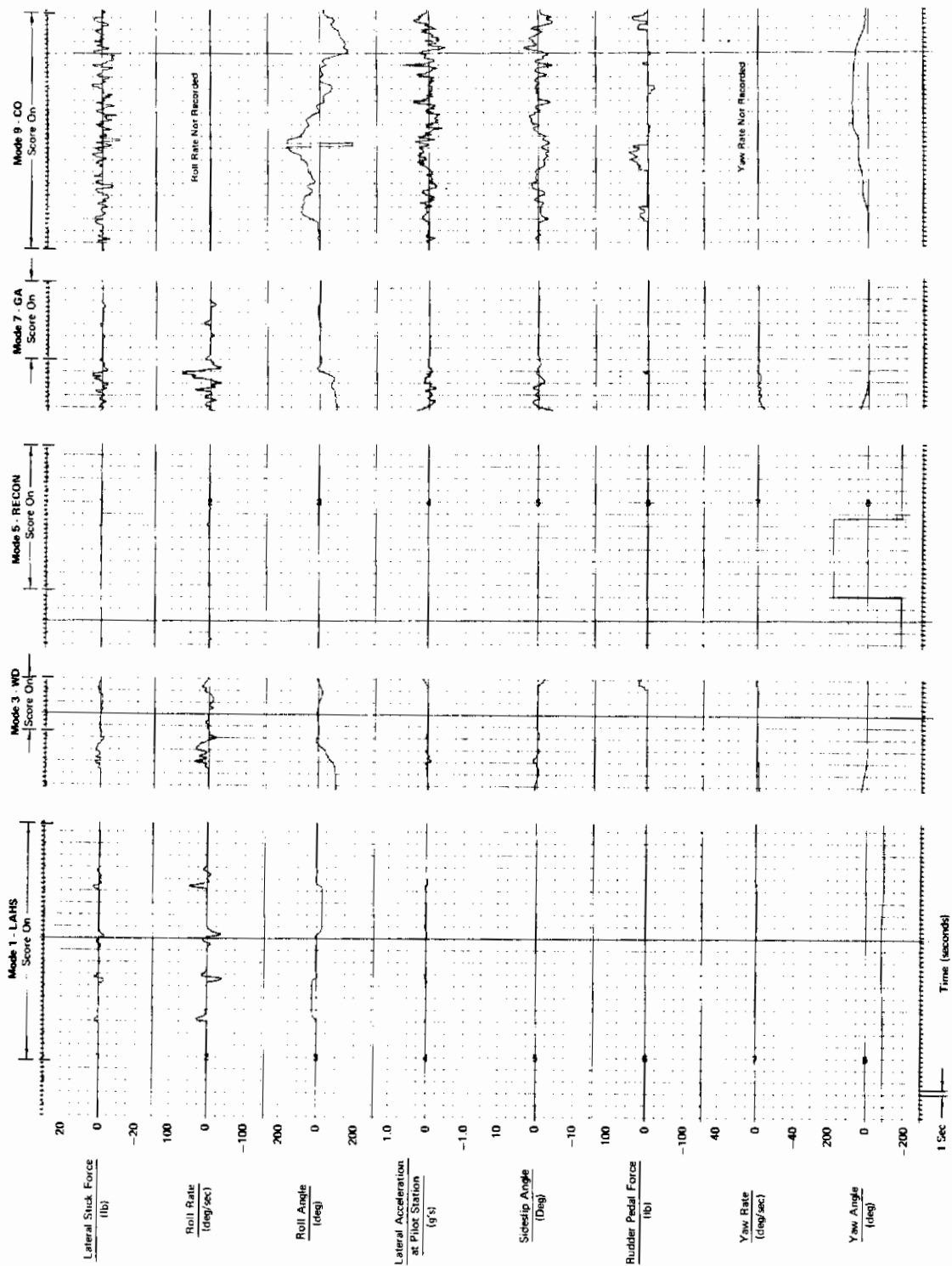

FIGURE 65
 TIME HISTORY RESPONSE DATA FOR LAHS, WD, RECON, GA, AND
 CO MODES OF OPERATION (RECORDER 3)

Contrails

are the rates of change of the corresponding pilot effort indexes tabulated on the digital print-plots. Both effort parameters are plotted on the same recorder channel by utilizing a multiplexing technique which time shares the channel voltage generated by the digital computer. Every 0.1 seconds the voltage corresponding to the longitudinal effort parameter is recorded on the top half of the recorded channel and the voltage corresponding to the lateral effort parameter is recorded on the bottom. The multiplexed signal is recorded in all mission phases except the air-to-air combat phase. In air-to-air combat phase this channel is utilized in a conventional way, recording only the longitudinal effort parameter. A sample strip chart record is shown in the fourth channel of Figure 63. In LAHS phase, two added parameters are recorded which are not used in other phases. They are the pitch error needle and the roll error needle signals. In air-to-air phase several additional digital-to-analog transformation channels (Adage) were needed to transmit the voltages required to drive the target airplane display. Because of this, the number of signals recorded in the air-to-air phase is reduced by six as shown in the sample strip chart plots, Figures 63 through 65. However, the remaining 17 channels of continuous plots in the air-to-air combat phase, together with all the discrete channels, still comprise a satisfactory time history record of all pertinent activity in air-to-air combat.

APPENDIX VI

WRITTEN INSTRUCTIONS PREPARED FOR SIMULATION PILOTS

This Appendix presents the written instructions given to the pilots in preparation for the simulation study. The instructions describe the SFCS work effort, purpose of the simulation, and the simulation procedure. In addition the pilots were given a mission profile plan and a table identifying the Cooper-Harper rating values as shown in Table VI of this report. The pilots also received a questionnaire for use in providing comments after each run as shown in Figure 27.

1. GENERAL

The purpose of this simulation program is to obtain information on the short period handling quality characteristics of a variable stability and response F-4 aircraft and Survivable Flight Control System (SFCS) combination, and to apply the solicited pilot comments and ratings toward the establishment of three axes candidate performance criteria expressed in the time domain. Outlined below are the main features of the simulation program, the planned simulation procedure, and the type of information which will be requested from the simulation pilots.

2. LONGITUDINAL C* CRITERIA

The longitudinal C* criteria expresses, in time domain form, the acceptable levels or characteristics desired in short period transient responses to step command inputs. Since the criteria are normalized to unity "steady state" value, it is independent of airframe or flight control system "gain", and only a function of short period dynamics. For a step of stabilator command input, the C* response is only dependent on flight path time constant, short period damping and frequency, and is independent of stabilator effectiveness. For a fly-by-wire flight control system with a step of stick force input, the criterion does not reflect the fly-by-wire "gain" but only the dynamics of the airframe as modified by the fly-by-wire flight control system.

The C* equation is specified as:

$$C^* = \Delta n_{z_p} + K_1 q$$

and represents a functional combination into one mathematical equation of what are believed to be the high and low speed longitudinal motion cues sensed by the pilot during aircraft maneuvering flight. The cross-over gain (K_1) combines pitch rate (low speed cue) with normal acceleration (high speed cue) into a dimensionally consistent equation for use in evaluating new designs against a given envelope of acceptability.

Contrails

One third of all simulation runs to be tested by pilots will include pre-determined variation in C* response characteristics and evaluation of their effect on pitch axis handling qualities for various pilot tasks.

The main purpose of this part of the simulation effort is to evaluate designs which satisfy the C* criterion and to determine if they are compatible with the mission modes of the F-4 aircraft. In addition, the effect of higher order dynamics and nonlinearities will be tested to determine to what degree they affect application of the C* criterion. Pilot comments and information are desired to determine if control laws should be based upon mission modes or tasks rather than the traditional short period handling qualities as provided by standard control systems.

3. LATERAL-DIRECTIONAL

Simulation and testing will be conducted to determine if the desired short period lateral-directional handling qualities can be described using new criteria.

a. Lateral

Specification data from MIL-F-8785B have been used to generate preliminary roll rate and roll acceleration time history criteria which reflect the desired transient characteristics in the roll axis for aileron command inputs. Pilot evaluation of selected configurations is desired in order to integrate desired roll axis handling qualities and establish more exact boundaries for the contemplated criteria.

b. Directional

Analytic studies performed to date have established two preliminary criteria for pilot evaluation and comment of adequacy in representing desired directional short period handling qualities.

The first of these shows the estimated amount of sideslip allowable during constant rolling maneuvers with aileron inputs and medium roll-to-sideslip ratios. MIL-F-8785B published data have been used to establish the preliminary time history boundaries of acceptable sideslip due to aileron inputs. Analysis and studies have also resulted in an alternate formulation of this directional time history criterion. The alternate form combines sideslip angle (low speed motion cue) and lateral acceleration (high speed motion cue) into an envelope of acceptability which resembles in its form the longitudinal C* criterion. The expression used in the new criterion is given as,

$$D^* = \Delta n_{y_p} + K_3 \beta$$

where the crossover gain (K_3) combines the high and low speed parts in a similar manner as in the longitudinal case.

Comments on directional response due to rudder pedal inputs are desired in order to aid establishing the transient characteristics necessary for improved flight performance with use of rudder pedals.

The goals of the lateral-directional documentation and testing are similar to those outlined for the longitudinal case; namely, to establish criteria which define handling qualities desired to provide improved mission mode performance, precision flying and guidance to control law developments.

4. INTER-AXIS COUPLING

A decoupled aircraft will be simulated and evaluated by the pilots to determine the degree of acceptability and desirability of this type of control. Pilot comments on resulting flying qualities will be solicited.

5. PROCEDURE

The simulation tests being planned will consist of an evaluation phase in which the pilots familiarize themselves with the hybrid simulation setup, and a documentation phase during which performance data and pilot rating information will be collected for the configuration to be tested.

a. Evaluation

Evaluation of the hybrid simulation setup is being planned in order to obtain pilot information and comments which will be used to modify equipment prior to documentation phase. It is desired to familiarize the pilots with the above objectives as formulated into pilot tasks and mission modes to be tested. Several test runs will be made by each participating pilot as a means of exercising the overall problem mechanization with hybrid simulation equipment.

b. Documentation

All participating pilots will evaluate the same configuration characteristics. The degree to which the pilots can accomplish their tasks and fly the aircraft will be established through Cooper-Harper ratings (Table VI) and other performance scoring techniques. It is planned that each configuration will be tested during the simulated mission as detailed in Table V.

It is the intent of the simulation plan to use the defined mission as a basis from which repeated runs are performed and evaluation of numerous longitudinal and lateral-directional configurations is accomplished. The mission modes and pilot tasks remain unchanged from one run to the next, and only the three axes handling qualities are altered.

Contracts

APPENDIX VII

SIMULATION PILOTS' COMMENTS

Pilots' comments reflecting assessment and evaluation of handling qualities as provided by each test configuration during fixed base man-in-the-loop simulations are included in this appendix in support of the documentation data presented in Section VII.

1. GENERAL

Comments from participating pilots were combined into applicable groups of related evaluations describing a specific configuration. This was necessary since some pilots spent more time in the simulation program and were able to repeat some test configurations more often. It was felt that their position on the "learning curve" was higher and their comments more applicable than those from pilots who had difficulty distinguishing programmed differences due to limited exposure. This consideration does not alter the validity of the performance data obtained from all pilots but only combines the comments into individual test configuration groups.

2. PILOT COMMENTS

The following comments were provided by the pilots during their evaluation of the test configurations used in the simulation:

a. Nominal (Reference) Configuration (See Figures 13 & 14)

The airplane responses generally look pretty good. I had good control in tracking the target. I did not see any tendency toward aircraft instability, or residual oscillations, or possible PIO. The airplane is stable. The harmony of control forces is fine.

Additional Remarks

One pilot commented adversely on the lateral-directional handling characteristics in those phases of the mission which involve any type of target tracking, that is in weapon delivery, ground attack, and air-to-air combat phases. In these phases it was difficult for him to anticipate the magnitude and duration of the roll transient required to correct a given azimuth error. Another pilot stated that the stick deflections, and forces, were a little high in these flight phases and this impaired his maneuvering capability.

b. Time Delay Configurations

o $\Delta T = 0.1$ seconds

This configuration is a little less sensitive than the nominal. It did not seem too uncomfortable for the small correction problem. If I over-exercised the longitudinal control I got myself in a PIO tendency which I think is due to the lag in the longitudinal control system. However, I was able to track the target.

Contrails

- o $\Delta T = 0.24$ seconds

Here it appears that the longitudinal response was decreased and it felt like more stick or more force or both were needed to do the maneuvering I wanted to do. The pitch response to command maneuvers was not quite as fast and that hurts in the air combat mode and it is annoying when you are trying to make large pitch changes to get into position for ground target. Although once you stabilize on the target and a heading, it does not seem to hurt your ability to stay there very much. The degradations noticed in the other aspects seem to be paramount and more critical in the air-to-air encounter.

c. Time Constant Configurations

- o $T_L = 0.25$ seconds

This run looked a lot like the nominal configuration. I think the short period was fairly good but maybe the damping was not as good as it could have been. A very minor problem with the PIO tendencies was noticeable during the first big correction, although the airplane seems to stabilize fairly well.

- o $T_L = 0.50$ seconds

I did not notice any very significant changes from the previous configuration ($T_L = 0.25$ seconds). I do not think we are changing anything very significantly. The response of the airplane is about the same in lateral and longitudinal axes.

- o $T_L = 1.0$ seconds

My impression was that the response was okay but the sensitivity was down. The airplane responded to a stick input immediately and there was not any particular problem of overshoot because of that. I thought that more stick deflection was required per g than, say, the nominal case. Although it did not really feel that way in the air combat mode, I was a little bit surprised that the air combat mode did not feel worse than it did.

- o $T_L = 2.0$ seconds

The short period response was changed significantly. I could never get the attitude change per stick change that I wanted, the response just was not fast enough. The stick force per g was probably also changed to a pretty high number. I was using longitudinal control from pretty much forward to quite a bit aft and I did not get that high g reading. The weapon delivery and ground attack were difficult because it was hard to pull the nose to the target and I think that is because the stick force per g was too high, although it might have been because the short period was slowed down.

Contrails

d. Nonlinear Configurations

- o $\tau_{1L} = 1.25$ seconds

The pitch response was decreased but the instability or the PIO tendency was increased. I found it difficult to maintain good pitch tracking. In the air-to-air mode, I initially started out tracking pretty well, but then once it got away from me I never did get back in the ball park with it. I do not know whether that was piloting technique or what, but I just could not seem to get it back on the target, once it got out of the initial tracking envelope.

- o $\tau_{1L} = 2.5$ seconds

The pitch axis is less sensitive than it has been, which aggravates making pitch corrections. There is too much stick deflection and force required for pitch changes. The air-to-air combat was unsatisfactory. I could not seem to pull the right amount of stick force to get the gun site on the target and to stabilize on the target, therefore I was overshooting both ways.

- o $\tau_{1L} = 5.0$ seconds

The precise tracking tasks are not too bad because you do not have to make very large pitch corrections and it seems to respond okay to very small pitch corrections. But it is obvious that the response and sensitivity are terrible for large corrections and in the weapon delivery modes (WD and GA) it is difficult to get on target. Once you get on target it is not too bad. Air combat is impossible. The pitch channel is characterized by poor sensitivity, poor response to large corrections, and a resulting overshoot when you make large pitch maneuvers.

e. Higher Order Configurations

- o Configuration 1 with low amplitude and low damping.

This configuration was pretty good for tracking; however, you get some tendency for the stick to oscillate and therefore for the airplane to oscillate after large pitch corrections.

- o Configuration 2 with intermediate amplitude and low damping.

I noticed stick oscillation present after corrective maneuvers. I could feel it when making any noticeable pitch corrections. You get a bit of residual stick oscillation and therefore airplane oscillation in pitch. I do not like it; however, I do not think it is going to show up much in scoring because it is controllable.

Contrails

- o $\zeta = 0.35$

That one had a nice short period, but the damping was not sufficient. I was getting some of that residual airplane oscillation after a small pitch correction. It was noticeable in dive delivery and ground attack, as you tried to get the pipper on the target. You could move the pipper there, but you could not stop it where you wanted to. The same thing happened in the air-to-air mode.

- o $\zeta = 0.1$

The longitudinal system is badly degraded. The damping is so bad that it is dangerous in all modes. The airplane could be flown but I just could not do anything with it. Every time you release pressure on the stick, or change the pressure at all, you set off the airplane oscillation. It is very bad in all five modes. I thought maybe it would not be so bad in the air combat mode, where you are constantly pulling g's, but it turns out it is just as bad there, because as soon as you change the stick force you set up the oscillation.

f. Roll Response Configurations

- o $T_R = 0.1$ seconds

I did not notice much difference between this configuration and the nominal. The lateral control appeared to be slightly easier to handle this time, although it was a little bit choppy. Perhaps in a real airplane that would slam me around in the seat a little bit when I decided to quit rolling.

- o $T_R = 0.5$ seconds

This configuration looked more like nominal than anything else to me.

- o $T_R = 1.0$ seconds

The roll response was too low and the roll was not properly damped and then when you centered the stick, the roll continued on for a little while. The large stick deflections make it pretty tough to do air combating.

- o $T_R = 1.5$ seconds

The whole airplane just feels sluggish right now, with poor lateral response due to the large deflection required, although it is reasonably stable. The lateral mode looks sloppy. It is not comfortable. It does not respond quite as quickly to the lateral stick deflection as the nominal airplane does. I can make a stick deflection and it will start rolling and when I stop the deflection it will keep on rolling.

Contrails

- o $T_R = 2.5$ seconds

This configuration has much poorer roll response, causing difficulties in making bank angle corrections. And when you try to roll out of the bank or neutralize the controls, the airplane keeps rolling, so it ends up being very sloppy in roll. It is difficult to make small bank angle corrections, because you have to use so much aileron and then you end up overshooting, since it does not stop rolling when you want it to stop rolling. The roll response is much too low. If you get the wings level at a point where you want them level, it tends to stay that way fairly well, because it requires a little more aileron input to roll off level, but it feels like a sloppier airplane generally. Most of the missions were difficult to perform.

g. Adverse/Proverse Yaw Configurations

- o Adverse/Proverse Yaw Configuration #1 (cf. Figures 25 and 26)

In this run the lateral and longitudinal matching was pretty good. The airplane was stable, and I did not see any significant undesirable characteristics either in the airframe or in the control system.

- o Adverse/Proverse Yaw Configuration #2 (cf. Figures 25 and 26)

This configuration looked pretty much the same as nominal. I did a few rudder kicks and so forth, looking for lateral-directional peculiarities, but I did not see anything unusual. I did not see any instability or residual stick or airplane oscillations.

- o Adverse/Proverse Yaw Configuration #3 (cf. Figures 25 and 26)

I did not have any trouble changing directions and the roll response and damping looked pretty good. I would find it difficult to discriminate between this configuration and the nominal. The responses are okay and the aircraft stability is okay.

- o Adverse/Proverse Yaw Configuration #4 (cf. Figures 25 and 26)

This configuration appears to have a combination of poor lateral control and poor lateral-directional stability. The airplane seems very sloppy. I had a difficult time in LAHS, and even in the reconnaissance phase it was difficult to keep the wings level. In ground attack it was very difficult to stabilize on the target directionally.

- o Adverse/Proverse Yaw Configuration #5 (cf. Figures 25 and 26)

In LAHS I had a problem with delayed response and overshoot. It seemed that this configuration had a lower roll rate and more lag in roll than the nominal configuration. The problem was not as noticeable in weapons delivery, possibly because of the outside

Contrails

reference. I had no problem in reconnaissance phase and only minor problems in the strafing run. However, I had a definite problem in the air combat mode in tracking the target, which I attribute to the lag in the lateral system.

h. Decoupled Configurations

The pertinent parameter values used with each decoupled configuration are listed in Figure 22.

o Decoupled Configuration 1

The lateral response is down quite a bit in this configuration, as compared to nominal. Because of the slow lateral response it is difficult to make small lateral corrections without overshooting, or to make them in time to really do any good. It is also more difficult to track the target with the slow lateral response and with the tendency to overshoot in this configuration.

o Decoupled Configuration 2

The lateral response in this configuration was faster than in the previous case (Decoupled Configuration 1); therefore it was easier to make lateral corrections in the LAHS phase. The weapons delivery also seemed easy, and the reconnaissance mode was no problem. In the ground attack mode I first noticed a tendency to overcorrect laterally. It was some sort of lateral oscillation, or a sort of lateral PIO. It seemed like I was overcorrecting in both the strafing run and in the air combat mode.

o Decoupled Configuration 3

The slow roll rate response in this configuration made it a bit difficult to zero the needle as fast as I would like, but I did not tend to overshoot quite as much as in the previous configuration which had slow roll response (Decoupled Configuration 1).

In weapon delivery and reconnaissance I had no particular problem, except that in weapon delivery I had a little bit of a problem settling on the target.

o Decoupled Configuration 4

In LAHS phase I liked the more positive lateral control on the needles. The dive bombing run and the reconnaissance phase were also okay. However, in the air-to-ground strafing and in the air combat I began to notice the lateral over-control tendency again. The roll response in this configuration seems to be the sort of response I like, except I do run into this over-controlling problem when I have to make large or moderately rapid corrections.

REFERENCES

1. Technical Report AFFDL-TR-70-135, "Survivable Flight Control System Program, Simplex Actuator Package", McDonnell Aircraft Company, November 1970.
2. MIL-F-8785B; "Military Specifications - Flying Qualities of Piloted Airplanes", 7 August 1969.
3. Chalk, C. R., Harris, T. M., Neal, T. P., Pritchard, F. E., Woodcock, R. J., "Background Information and User Guide for MIL-F-8785B," AFFDL Report, (Unnumbered), June 1969.
4. Tobie, H. N., Elliott, E. M., "New Short Period Handling Quality Criterion for Fighter Aircraft", Boeing Document No. D6-17841 T/N, September 1965.
5. MCAIR Report G951, "Survivable Flight Control System Development Proposal", Volume I, 8 February 1969.
6. Mayer, J. P., Hamer, H. A., "A Study of Service Imposed Maneuvers of Four Jet Fighter Airplanes in Relation to Their Handling Qualities and Calculated Dynamics Characteristics", NACA RM L55E19, 15 August 1955.
7. Berger, J. B., Meyers, M., Wallace, R. E., "Improved Model for Aerial Gunnery Effectiveness", Technical Report AFATL-TR-68-112, September 1968.
8. Cooper, G. E., Harper, P. R., "The Use of Pilot Rating in the Evaluation of Aircraft Handling Qualities", NASA TN D-5153, April 1969.
9. Ashkenas, I. L., "A Study of Conventional Airplanes Handling Qualities Requirements, Part 1, Roll Handling Qualities," AFFDL-TR-65-138, Part 1, November 1965.
10. Ashkenas, I. L., "A Study of Conventional Airplanes Handling Qualities Requirements, Part 2, Lateral Directional Oscillatory Handling Qualities", AFFDL-TR-65-138, Part 2, November 1965.
11. MCAIR Report No. 9842, Model F/RF-4B-C Aerodynamic Derivatives, dated 10 February 1964.

Unclassified

Security Classification

DOCUMENT CONTROL DATA - R & D

(Security classification of title, body of abstract and indexing annotation must be entered when the overall report is classified)

1. ORIGINATING ACTIVITY (Corporate author) McDonnell Aircraft Company McDonnell Douglas Corporation		2a. REPORT SECURITY CLASSIFICATION Unclassified	
		2b. GROUP N/A	
3. REPORT TITLE Survivable Flight Control System Interim Report No. 1 Studies, Analyses and Approach Supplement for Control Criteria Studies			
4. DESCRIPTIVE NOTES (Type of report and inclusive dates) Interim Report - July 1969 - May 1971			
5. AUTHOR(S) (First name, middle initial, last name) Robert L. Kisslinger Michael J. Wendl			
6. REPORT DATE May 1971		7a. TOTAL NO. OF PAGES 195	7b. NO. OF REFS 11
8a. CONTRACT OR GRANT NO. F33615-69-C-1827, PZ05		9a. ORIGINATOR'S REPORT NUMBER(S)	
b. PROJECT NO. 680J			
c.		9b. OTHER REPORT NO(S) (Any other numbers that may be assigned this report)	
d.		AFFDL-TR-71-20, Supplement 1	
10. DISTRIBUTION STATEMENT This document has been approved for public release. Its distribution is unlimited.			
11. SUPPLEMENTARY NOTES		12. SPONSORING MILITARY ACTIVITY Air Force Flight Dynamics Laboratory Air Force Systems Command Wright-Patterson Air Force Base, Ohio	
13. ABSTRACT The Survivable Flight Control System (SFCS) Program is an advanced development program of which the principal objective is the development and flight test demonstration of an SFCS utilizing Fly-By-Wire and Integrated Actuator Package techniques. The studies and analyses conducted to date have sufficiently defined the system requirements to provide a definition of an approach to the implementation of the SFCS. The results of these studies and the definition of the approach are presented in the basic report. Details of the Control Law Development, and Hydraulic Power Actuation studies are presented in report supplements 2 and 3, respectively. The results of the Control Criteria studies are presented in this supplement 1. With the introduction of highly augmented flight control systems and fly-by-wire systems such as the SFCS, increased concern over the adequacy of existing handling qualities specifications and performance criteria have been expressed. As a result, a control performance investigation has been conducted in an attempt to define both the longitudinal and lateral-directional short period performance criteria requirements, and determine if the control laws should be based on mission modes or tasks rather than the traditional short period handling qualities and control techniques. Based on an extensive literature survey and a preliminary analysis, three candidate time history performance criteria were proposed. These were a normalized blend of pitch rate and normal acceleration, or C*, for the pitch axis; a blend of roll rate			

13. ABSTRACT (CONTINUED)

and roll acceleration for the roll axis; and a blend of lateral acceleration and sideslip, or D^* , for the directional axis.

In order to verify the above candidate criteria, a six degree-of-freedom, fixed base, large amplitude piloted simulation was conducted. The basic approach was to define the minimum level of acceptable handling qualities by systematically evaluating various flight control system configurations and mission modes. Specifically, the following parameters were varied: time delays, time constants, nonlinearities, higher order effects, adverse or proverse yaw, and decoupled lateral-directional dynamics. In addition, the mission modes included low altitude high speed instrument tracking, weapon delivery (bomb run), reconnaissance, ground attack (strafing run) and air-to-air combat. The performance indicators and system effectiveness metrics included pilot comments, Cooper-Harper ratings, pilot effort index, time histories, and statistical data in the form of figures of merit, histograms and cumulative distributions.

Documentation data from the control performance analysis and simulation studies resulted in slight modifications to the candidate criteria boundaries. Moreover, the results of this study indicate that performance criteria, except possibly for specialized tasks such as air-to-air refueling and landing, need not be based on mission modes, but rather on the short period handling qualities presented in this report.

Contrails

14. KEY WORDS	LINK A		LINK B		LINK C	
	ROLE	WT	ROLE	WT	ROLE	WT
Handling Qualities Manned Simulation Mission Modes Tracking Equations Transient Response Criteria Weapon Delivery						