

SIMULATED SOLAR IRRADIATION AND ITS PHOTOCHEMICAL EFFECTS ON PLASTIC SPACECRAFT MATERIALS

By

Philip L. Hanst
Vincent H. Early
Paul T. Woodberry
Augustus C. Walker, Jr.

RESEARCH AND ADVANCED DEVELOPMENT DIVISION
AVCO CORPORATION
Wilmington, Massachusetts

ABSTRACT

An apparatus has been devised and constructed for testing the photochemical effects of simulated solar irradiation on spacecraft materials. The novel and significant part of the apparatus is a plasma-jet light source which gives an exceptionally high intensity of ultraviolet continuum.

Fifty hours irradiation of samples of a plastic material has produced marked photochemical decomposition and changes in physical properties. The solar absorptivity of the samples has increased by as much as fifty percent.

Further development of the facility is proposed. It is suggested that the light falling on the receiving area can be made parallel, uniform in intensity, and similar in spectral distribution to solar irradiation over the wavelength range from 2000 to 40,000 Å.

I. INTRODUCTION

A. SOLAR SPECTRUM

The solar spectrum is a composite of radiations and absorptions occurring in various regions of the solar atmosphere. In general, the emitting gases are not in thermal equilibrium and no specific temperature can be assigned to the source. There is much fine structure in the solar spectrum, such as the Fraunhofer absorption lines and the intense emission lines of specific elements. The intensity and spectral distribution of solar irradiation are the subjects of continuing investigation. Based on present knowledge however, solar irradiation at the outside of the earth's atmosphere can be described qualitatively by saying that it resembles the radiation from a blackbody at 5800° Kelvin with a total intensity of 1.4 kilowatts per square meter. This description is approximately correct in the wavelength region between 1800 and 40,000 Angstroms which includes about 99 percent of the total radiation.

B. DUPLICATION OF SOLAR SPECTRUM

The main difficulty in simulating solar irradiation is obtaining the requisite intensity and spectral distribution in the ultraviolet part of the spectrum. Although only about 12 percent of the solar radiation occurs at wavelengths shorter than 4000 Angstroms, photochemically it is the most active 12 percent. Without it, photochemical decomposition of plastic spacecraft materials would probably not be a serious problem.

Radiating solids, such as lamp filaments, can only be maintained at temperatures much lower than 5800° K; hence, they are relatively weak in ultraviolet radiation. A comparison of blackbody emission intensities in the ultraviolet is given in Table I for Kelvin temperatures of 5800° (sunlight), 3900° (carbon arc), and 3000° (tungsten lamp filament).

To obtain intense ultraviolet in the laboratory, one usually resorts to electrical discharges through gases. These discharges produce emission spectra from atomic and molecular species which are not thermally equilibrated. Usually, a line spectrum is obtained as for example, in mercury vapor lamps. Ultraviolet continua are obtained from hydrogen discharge tubes, fluorescent lamps, and discharges through rare gases at high pressure. Each of these sources of continua, however, has its limitations for sunlight simulation. The hydrogen discharge tube has too much short wavelength ultraviolet, not enough long wavelength ultraviolet, and practically no visible light. The fluorescent tubes are deficient in short wavelength ultraviolet, and also, emit over such a broad area that it would be difficult to obtain a parallel beam of sufficient intensity from them. The high-pressure, rare-gas lamps, such as xenon lamps, provide one of the best commercially available approximations of sunlight, but still are deficient in short wavelength ultraviolet.

TABLE I

COMPARISON OF EMISSION INTENSITIES IN THE ULTRAVIOLET
FOR SOURCES EMITTING EQUAL AMOUNTS OF RADIATION
AT 4000 ÅNGSTROMS

Source	Emission Intensity		
	Ångstroms 4000	Ångstroms 3000	Ångstroms 2000
	Watts	Watts	Watts
5800°K Blackbody (Sunlight)	1000	561	68
3900°K Blackbody (Carbon Arc)	1000	172	3
3000°K Blackbody (Tungsten Lamp)	1000	72	0.2

A light source which does provide the requisite intensity of ultraviolet continuum for solar radiation simulation has been recently developed at Avco RAD. The source is the argon plasma jet. In this device, argon gas at atmospheric pressure is heated by means of an electrical discharge to temperatures of 7000°K and higher. At these temperatures, the argon emits an intense continuum which extends throughout the ultraviolet and visible spectral regions and into the infrared. There are a few weak lines in the spectrum, but their total intensity is very small compared to the total intensity in the continuum. The spectral distribution of emitted light can be changed by increasing or decreasing the power input. A greater power input raises the temperature of the gas and shifts the spectrum farther into the ultraviolet. The source can be operated continuously for an almost unlimited length of time.

II. EXPERIMENTAL INVESTIGATION OF PHOTOCHEMICAL DECOMPOSITION OF PLASTICS

The argon, plasma-jet light source has been used at Avco RAD in an experimental investigation of the effects of solar irradiation on plastics. The simple apparatus setup for the purpose is diagrammed in figure 1. In this setup, the light passes through the quartz window, into the evacuated chamber, and impinges on the samples which are mounted against the water-cooled endplate. The spectral distributions and intensities measured at the sample mount are shown in figure 2. The intensity has been greater at the upper part of the receiving area than at the lower part. The reason for this variation is that the light is being taken from the side of the arc, and the intensity of emission falls rapidly as the viewing angle approaches 90 degrees off-axis.

The material tested has been an experimental heat-shield plastic which consists of a reinforced epoxy resin and inorganic additives. A description of the various samples is given in Table II. Surface effects have been noticed on the samples after only three hours of irradiation. Most of the samples darkened considerably and an oil evaporated which condensed on the water-cooled backplate. The decomposition apparently extended only about 0.001 inch into the samples. Nevertheless, the effect on the solar absorptivity of the samples is significant. This effect is shown in Table II.

The solar absorptivities of the samples have been estimated by the following technique. Two samples of each material are exposed side by side to the light of the argon plasma jet. One of the two samples is blackened to produce complete light absorption; it then serves as a calorimeter or calibration sample. The other sample is the one whose absorptivity is to be measured. The two samples are exposed to the argon light long enough to produce a temperature rise of a few degrees which has been measured on thermocouples embedded in the samples. The intensity of light has been adjusted, so that the samples are heated up at a considerably greater rate than their rate of cooling due to conduction to the surrounding air. After the light is shut off and some time is allowed for the absorbed heat to distribute itself uniformly throughout the samples, the temperatures are read. Since the heat capacities of the two samples are the same, the ratio of temperature increases is assumed to be equal to the ratio of absorptivities. Since the spectral distribution of the incident light is similar to the spectral distribution of solar irradiation, the measured absorptivity is probably not too much different from the true solar absorptivity.

One experiment has been performed to demonstrate that the decomposition on the exposed surface of the samples is a photochemical reaction due principally to the ultraviolet part of the spectrum. A sample of reinforced epoxy resin has been exposed to the light for four hours with a piece of pyrex glass covering part of the front surface. Pyrex passes almost all of the light of wavelength

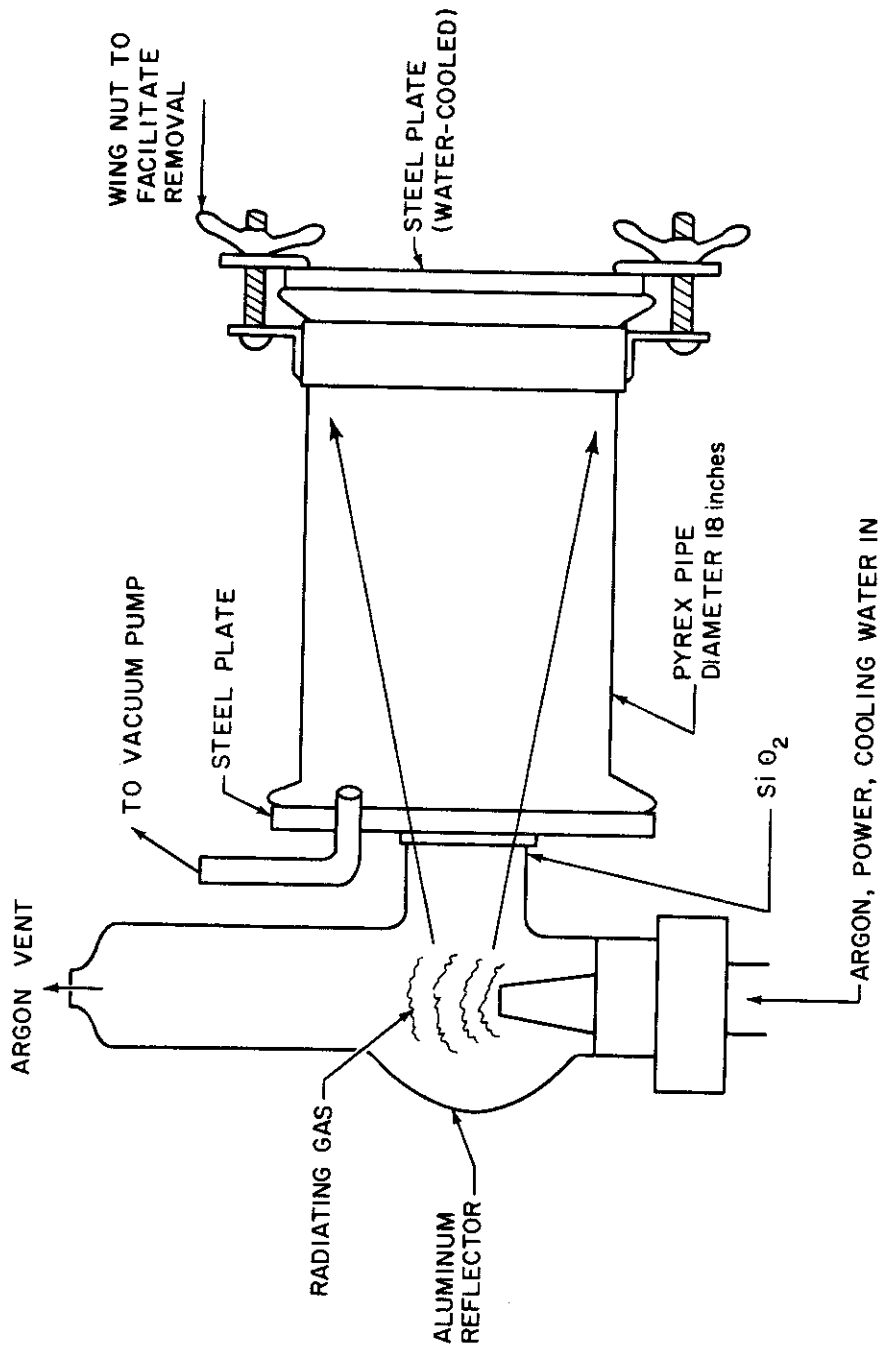

Figure 1 EXPERIMENTAL ARRANGEMENT OF SOLAR SIMULATOR
60-3559

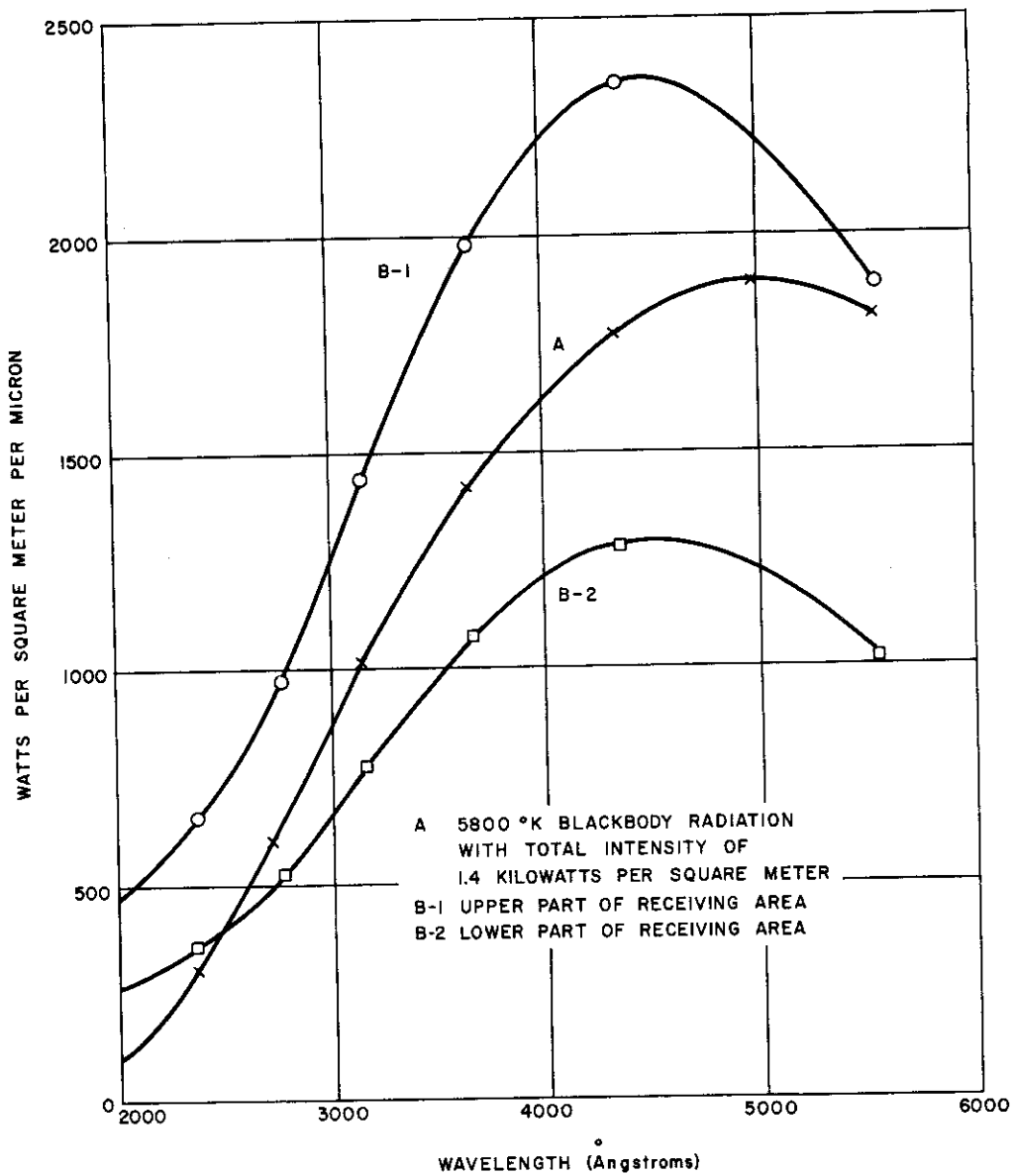

Figure 2 SPECTRAL DISTRIBUTION AND INTENSITY OBTAINED FROM RAD SOLAR SIMULATOR 60-3560

TABLE II
SOLAR ABSORPTIVITIES OF REINFORCED EPOXY
RESIN SAMPLES WITH ADDITIVES

Additive	Before Exposure	After 25 Hours Irradiation	After 50 Hours Irradiation
Percent			
0.5 Magnesia	0.50	0.59	0.68
0.5 Titania	0.42	0.62	0.62
1.5 Aluminum Flake	0.82	0.92	0.93
0.5 FR-2 Flame Retarder	0.50	0.51	0.56
0.5 Dow HCB Ultraviolet Absorber	0.44	0.48	0.58
0.5 Potassium Titanate	0.48	0.58	0.69
None	0.49	0.56	0.61

longer than 3200 Ångstroms and practically no light of wavelength shorter than 3200 Ångstroms. The exposed sample and glass strip are shown in figure 3. The original appearance of the sample is preserved on the sides and on top and bottom where the surface is shielded by the sample holder. The pyrex-covered center strip discolored only slightly, whereas the uncovered areas darkened considerably. This result indicates strongly that the decomposition is photochemical and not thermal.

Further indication of the photochemical nature of the decomposition has been obtained from results of heating this resin under vacuum conditions, using an infrared source. The back surfaces of the specimens have been maintained at 30° C, and the front surfaces are heated to 190° C. Practically no discoloration of the front surfaces has been observed. This result is in sharp contrast to the rapid surface darkening that occurred when similar specimens, exposed to simulated solar radiation, have reached this surface temperature. Surface discoloration of the resin by ultraviolet has been observed when surface temperatures are maintained as low as 90° C.

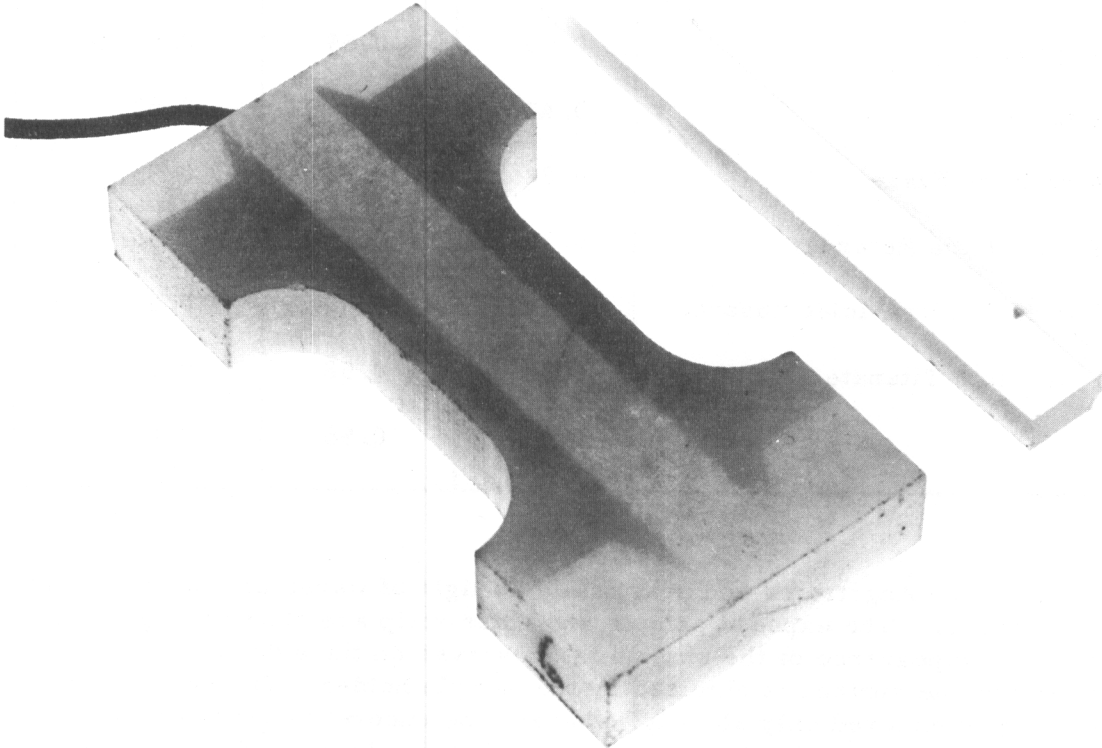

Figure 3 RESULTS OF SIMULATED SOLAR IRRADIATION OF PLASTIC WITH
AND WITHOUT GLASS FILTER
P5478

III. FURTHER DEVELOPMENT OF SOLAR IRRADIATION-SIMULATION FACILITY

Further development work on this simulation facility should include the following:

1. The measurement of the spectral distribution and intensity of the plasma-jet radiation should be extended farther into the infrared. If the infrared should prove to be weak compared with the ultraviolet, the plasma-jet radiation could be supplemented by the infrared rich light from a tungsten filament lamp. Building up the spectral distribution in the infrared would not be difficult, and it would be expected that the solar radiation intensity and spectral distribution could be duplicated to within ± 5 percent over the entire wavelength range from 2000 to 40,000 Angstroms.
2. The distribution of light intensity on the receiving area should be made more uniform. This could be accomplished by the use of a collimating mirror which would collect the light head-on from the arc rather than from the side. An area of at least two or three square feet could be illuminated uniformly with the maximum intensity not more than two or three percent greater than the minimum.
3. The light beam should be made parallel. A parallel beam could be achieved to within a few percent by the use of an inexpensive off-axis paraboloidal collimator. High optical quality would not be required. A schematic diagram of the proposed improved test chamber is shown in figure 4.

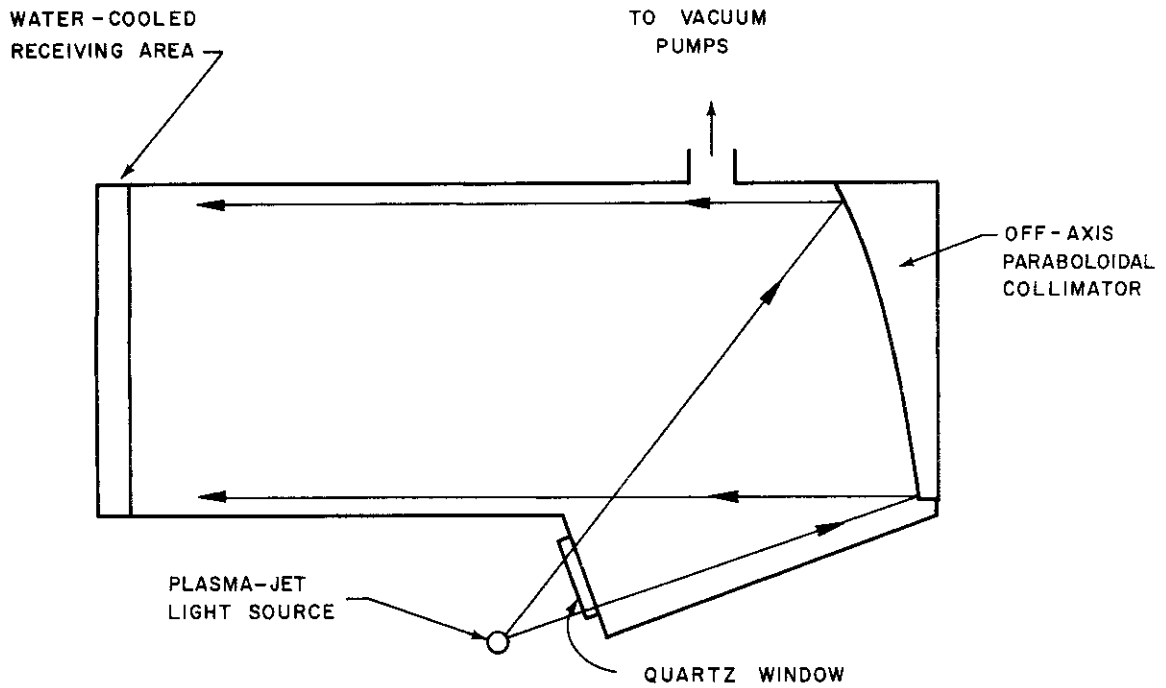

Figure 4 IMPROVED SOLAR SIMULATOR CHAMBER
60-3558