

AFFDL-TR-66-43
PART XIII

AIRCRAFT GROUND-FLOTATION INVESTIGATION
PART XIII. DATA REPORT ON TEST SECTION 13

J. WATKINS and G. HAMMITT, II,

*** Export controls have been removed ***

This document is subject to special export controls and each transmittal to foreign governments or foreign nationals may be made only with prior approval of the Air Force Flight Dynamics Laboratory (FDFM), Wright-Patterson Air Force Base, Ohio 45433.

FOREWORD

The investigation described herein constitutes one phase of studies conducted during 1964 and 1965 at the U. S. Army Engineer Waterways Experiment Station (WES) under U. S. Air Force Project No. 410-A, MIPR No. AS-4-177, "Development of Landing Gear Design Criteria for the CX-HLS Aircraft." (The CX-HLS is now designated C-5A.) This program was sponsored and directed by the Landing Gear Group, Air Force Flight Dynamics Laboratory, Research and Technology Division, Mr. R. J. Parker, Project Engineer.

These tests were conducted by personnel of the WES Flexible Pavement Branch, Soils Division, under the general supervision of Messrs. W. J. Turnbull, A. A. Maxwell, and R. G. Ahlvin, and the direct supervision of Mr. D. N. Brown. Other personnel actively engaged in this study were Messrs. C. D. Burns, D. M. Ladd, J. E. Watkins, H. H. Ulery, Jr., W. J. Hill, Jr., and G. M. Hammitt II. This report was prepared by Messrs. Watkins and Hammitt.

Directors of WES during the conduct of this investigation and preparation of this report were Col. Alex G. Sutton, Jr., CE, and Col. John R. Oswalt, Jr., CE. Technical Director was Mr. J. B. Tiffany.

Publication of this technical documentary report does not constitute Air Force approval of the report's findings or conclusions. It is published only for the exchange and stimulation of ideas.



AIVARS V. PETERSONS
Actg Chief, Mechanical Branch
Vehicle Equipment Division
AF Flight Dynamics Laboratory

Contrails

ABSTRACT

The work presented in this data report was undertaken as part of an overall program to develop ground-flotation criteria for the C-5A aircraft. A test section was constructed to a width adequate for two test lanes. Each lane was divided into three items having different subgrade CBR values and different traffic surfaces. Item 1* was surfaced with modified T11 aluminum landing mat, item 2 with M8 steel landing mat, and item 3 remained unsurfaced. Traffic was applied to both lanes using a 70,000-lb test load on a twin-wheel tracking assembly consisting of two 25.00x28, 30-ply aircraft tires inflated to 50 psi. On one lane the wheels were spaced 58.5 in. c-c and on the other lane wheel spacing was 29.5 in. c-c.

The information reported herein includes layout of the test lanes, characteristics and print dimensions of the load assembly tires, and data collected on soil strengths, surface deformations and deflections, and drawbar pull. The traffic-coverage level is given at which each test item was considered failed.

Contrails

Contrails

CONTENTS

	<u>Page</u>
SECTION I: INTRODUCTION	1
SECTION II: DESCRIPTION OF TEST SECTION AND LOAD VEHICLE.	2
Description of Test Section.	2
Load Vehicle	2
SECTION III: APPLICATION OF TRAFFIC, FAILURE CRITERIA, AND DATA COLLECTED	3
Application of Traffic	3
Failure Criteria and Data Collected.	3
SECTION IV: BEHAVIOR OF ITEMS UNDER TRAFFIC AND TEST RESULTS.	6
Lane 28.	6
Lane 29.	8
SECTION V: PRINCIPAL FINDINGS	11
TABLES 1 AND 2	
FIGURES 1-20	

ILLUSTRATIONS AND TABLES

<u>Figure</u>		<u>Page</u>
1.	Traffic distribution patterns on Test Section 13	3
2.	Load Vehicle	15
3.	Lane 28, item 1, prior to traffic	15
4.	Lane 28, item 1, after 700 coverages of traffic (failure)	16
5.	Lane 28, item 2, prior to traffic	16
6.	Lane 28, item 2, after 700 coverages of traffic (failure)	17
7.	Lane 28, item 3, prior to traffic	17
8.	Lane 28, item 3, after 200 coverages of traffic (failure)	18
9.	Lane 29, item 1, prior to traffic	18
10.	Lane 29, item 1, after 140 coverages of traffic (failure)	19
11.	Lane 29, item 2, prior to traffic	19
12.	Lane 29, item 2, after 200 coverages of traffic (failure)	20
13.	Lane 29, item 3, prior to traffic	20
14.	Lane 29, item 3, after 200 coverages of traffic (failure)	21
15.	Layout of Test Section 13 and summary of test results	22
16.	Layout of surfaced items	23
17.	Tire-print dimensions and tire characteristics	24
18.	Average cross-sectional deformations	25
19.	Permanent profile deformations	26
20.	Average deflections	27

<u>Table</u>		
1.	Summary of Traffic Data, Test Section 13	13
2.	Summary of CBR, Density, and Water Content Data, Test Section 13	14

SUMMARY

Test Section 13 is one phase of a comprehensive research program to develop ground-flotation criteria for heavy cargo-type aircraft. Section 13 consisted of two similar traffic lanes, lanes 28 and 29, each of which was divided into three items (figure 15). Each item was constructed to a different subgrade CBR value and had a different traffic surface. Item 1 was surfaced with modified T11 aluminum landing mat, item 2 with M8 steel landing mat, and item 3 remained unsurfaced.

Traffic was applied to both lanes using a 70,000-lb test load on a twin-wheel tracking assembly consisting of two 25.00x28, 30-ply aircraft tires inflated to 50 psi. On lane 28 the wheels were spaced 58.5 in. c-c and on lane 29 the wheel spacing was 29.5 in. c-c.

The lanes in Test Section 13 were trafficked to failure in accordance with the criteria designated in Part I of this report. Data were recorded throughout testing to give a behavior history of each item. Using the test criteria mentioned above, it was possible to directly compare the effects of trafficking with a twin-wheel assembly using different wheel spacings. Basic performance data are summarized in the following paragraphs.

Lane 28

Item 1

The item was considered failed due to elastic deflection at 700 coverages. The rated CBR was 2.1.

Item 2

The item was considered failed due to roughness at 700 coverages. The rated CBR was 2.8.

Contrails

Item 3

The item was considered failed due to roughness at 200 coverages.
The rated CBR was 4.7.

Lane 29

Item 1

The item was considered failed due to roughness at 140 coverages.
The rated CBR was 1.8.

Item 2

The item was considered failed due to roughness at 200 coverages.
The rated CBR was 2.8.

Item 3

The item was considered failed due to roughness at 200 coverages.
The rated CBR was 4.5.

AIRCRAFT GROUND-FLOTATION INVESTIGATION

PART XIII DATA REPORT ON TEST SECTION 13

SECTION I: INTRODUCTION

The investigation reported herein is one phase of a comprehensive research program being conducted at the U. S. Army Engineer Waterways Experiment Station (WES), Vicksburg, Miss., as part of U. S. Air Force Project No. 410-A, MIPR No. AS-4-177, to develop ground-flotation criteria for the C-5A, a heavy cargo-type aircraft. Specifically, the tests reported herein were conducted to determine the effect of wheel spacing of twin-wheel landing-gear assemblies on landing mat and unsurfaced soils under similar conditions of loading.

Prosecution of this investigation consisted of constructing two similar traffic lanes and subjecting them to equal test loads with twin-wheel landing-gear assemblies using different wheel spacings for the two lanes. This report presents a description of the test section and wheel assemblies, and gives results of traffic. Equipment used, types of data and method of recording them, and general test criteria are summarized herein; more complete explanations and illustrations appear in Part I of this report.

Contrails

SECTION II: DESCRIPTION OF TEST SECTION AND LOAD VEHICLE

Description of Test Section

Test Section 13 (figure 15) was constructed within a roofed area in order to allow control of the subgrade CBR (California Bearing Ratio) in the test items. Section 13 was located on the same site as prior Test Sections 1, 3, and 5 in this series, the original construction of which is described in Part II of this report. The underlying subgrade was undisturbed by prior tests on the site so that in construction of Section 13 only the upper 24 in. of soil was excavated. The excavated area was back-filled to the original grade level in four compacted lifts with a heavy clay soil (buckshot; classified as CH according to the Unified Soil Classification System, MLL-STD-619). The fill material used was a local clay with a plastic limit of 27, liquid limit of 58, and plasticity index of 31. Gradation and classification data for the subgrade material are given in Part I.

Two traffic lanes, each divided into three items, were constructed in the test section. Different subgrade strengths were obtained in the items (figure 15) by controlling the water content and compaction effort. Items 1 and 2 were surfaced with modified T11 aluminum landing mat and M8 steel landing mat, respectively (figure 16), and item 3 remained unsurfaced. The landing mats used are described and illustrated in Part I.

Load Vehicle

The load vehicle used for trafficking test lanes in Section 13 is shown in figure 2. Load cart construction, details of linkage between the load compartment and prime mover, and method of applying load are explained in Part I. For trafficking lanes 28 and 29, a twin-wheel assembly was used with a 70,000-lb test load. The assembly consisted of two 25.00x28, 30-ply aircraft tires inflated to 50 psi with wheel spacing 58.5 and 29.5 in. c-c for lanes 28 and 29, respectively. Tire-print data and pertinent tire characteristics are given in figure 17.

SECTION III: APPLICATION OF TRAFFIC, FAILURE CRITERIA, AND DATA COLLECTED

Application of Traffic

Traffic was applied to the test lanes in a nonuniform pattern with intensity of traffic being varied within each lane to produce three zones of approximately 100, 80, and 20 percent traffic coverage. Traffic so distributed within a traffic lane simulates as nearly as possible the bell-shaped traffic distribution curve which results from the wander of aircraft from the lane center line. The coverage levels referred to in the tables and text herein are the total number of coverages applied to the 100 percent coverage zone. The corresponding number of coverages applied to the outer traffic zones is proportional to the percentage factor for the respective zones as shown in figure 1. Typically, the lane widths used were not exact multiples of the tracking tire widths and spacings so that it was necessary to determine a coverage factor for each lane to compensate for overlap or gaps in the traffic pattern.

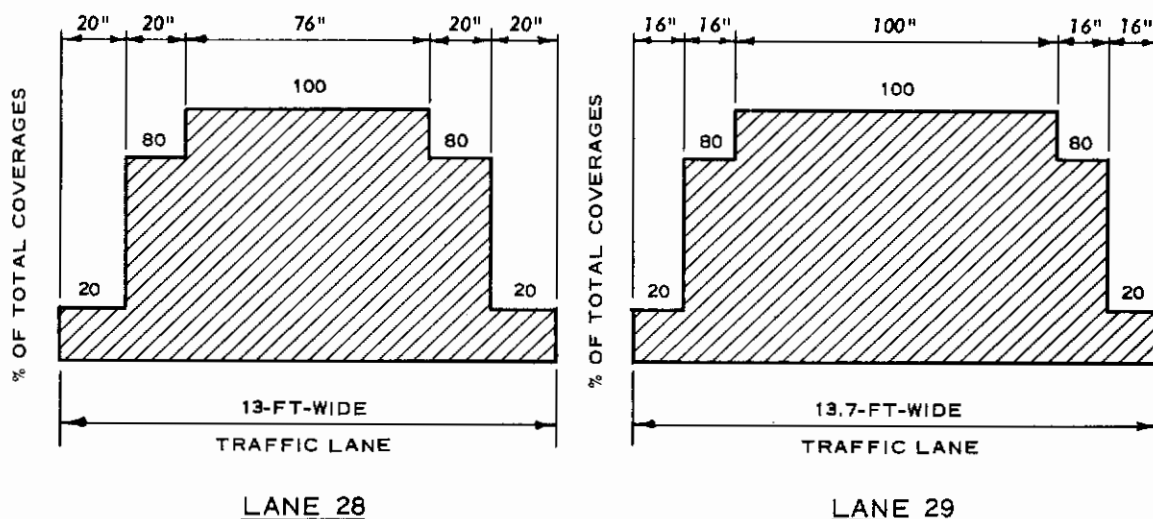

Figure 1. Traffic distribution patterns on Test Section 13

Failure Criteria and Data Collected

Failure criteria used in this investigation and descriptive terms used in presentation and discussion of data in all parts in this report are presented in Part I. A general outline of types of data collected is given in the following paragraphs. Details on apparatus and procedure for obtaining specific measurements are given in Part I.

Contrails

CBR, water content, and dry density

CBR, water content, and dry density of the subgrade were measured for each test item prior to application of traffic, at intermediate coverage levels, and at failure. After traffic was concluded on an item, a measure of subgrade strength termed "rated CBR" was determined. Rated CBR is generally the average CBR value obtained from all the determinations made in the top 12 in. of soil during the test life of an item. In certain instances, extreme or irregular values may be ignored if the analyst decides that they are not properly representative.

Surface roughness, or differential deformation

Surface roughness, or differential deformation, measurements were made using a 10-ft straightedge at various traffic-coverage levels on all items. Rut depths were measured for unsurfaced items, and dishing effects of individual mat panels in the mat-surfaced items were recorded.

Deformations

Deformations, defined as permanent cumulative surface changes in cross section or profile of an item, were charted by means of level readings at pertinent traffic-coverage levels.

Deflection

Deflection of the test surface under an individual static load of the tracking assembly was measured at various traffic-coverage levels on both surfaced and unsurfaced items. Level readings on the item surface on each side of the load wheels and on a pin and cap device directly beneath a load wheel provided deflection data. Both total (for a single loading) and elastic (recoverable) deflections were measured on unsurfaced items. All mat deflection was for practical purposes recoverable, i.e. total deflection equaled elastic deflection. The pin and cap device for measuring deflection directly beneath load wheels was applied to the subgrade of surfaced items through a hole (existing or cut) in the mat.

Rolling resistance

Rolling resistance, or drawbar pull, measurements were performed with the load vehicle over each test item at designated coverage levels. Three types of drawbar measurements were taken: (a) maximum force required to overcome static inertia and commence forward movement of the load cart, termed "initial DBP"; (b) average force required to maintain a constant speed once the load vehicle is in motion, termed "rolling DBP"; and (c) maximum force obtained during the constant speed run, termed "peak DBP."

Contrails

Mat breaks

Mat breaks on the surfaced items were inspected, classified by type, and recorded at various coverage levels.

Contrails

SECTION IV: BEHAVIOR OF ITEMS UNDER TRAFFIC AND TEST RESULTS

Lane 28

Behavior of items under traffic

Item 1. Figure 3 shows item 1 prior to traffic. At 550 coverages traffic was temporarily halted because the tires were rubbing the saddle of the load cart. At this point all pertinent data were gathered including CBR determinations. The tires were respaced to 56 in. c-c and traffic continued. Item 1 was considered failed at 700 coverages due to elastic deflection (figure 4). The rated CBR was 2.1.

Item 2. Figure 5 shows item 2 prior to traffic. The item held up well under traffic with relatively few mat breaks and deformation which developed slowly. Item 2 was considered failed at 700 coverages due to roughness (figure 6). The rated CBR was 2.8.

Item 3. Figure 7 shows item 3 prior to traffic. Considerable subgrade settlement occurred as trafficking progressed but differential deformations and rutting were slow in developing. The item was considered failed at 200 coverages (figure 8). At failure average transverse and diagonal differential deformations considerably exceeded rutting. The rated CBR of the item was 4.7.

Test results

Results of trafficking lane 28 are summarized in table 1. Soil test data are given in table 2. Table 1 contains drawbar pull values for the load vehicle operated over an asphalt-paved strip for comparison with drawbar pull values recorded on the test lane.

Item 1. Item 1 was considered failed at 700 coverages due to elastic deflection. The following information was obtained from traffic tests on item 1.

- a. Roughness. At failure the average transverse and diagonal differential deformations were 1.35 and 1.54 in., respectively (table 1). Average dishing of individual panels was 0.38 in. at failure.
- b. Deformation. Average cross-section and profile deformations are shown in figures 18 and 19, respectively, for several coverage levels. The figures show very little mat deformation although there was considerable subgrade settlement. The maximum profile deformation at failure was 1.7 in. along the joint line 1.5 ft west of the lane center line.

Contrails

- c. Deflections. Average elastic mat deflections shown in figure 20 increased generally with traffic. The largest average deflection (4.10 in.) was recorded with the load wheels centered on a panel end joint at the 700-coverage level. At the same coverage level, the elastic subgrade deflection was 1.1 in. Elastic mat deflections were greatly exaggerated by the mat standoff, or bridging effect resulting from settlement of the subgrade with traffic.
- d. Rolling resistance. Table 1 shows drawbar pull values at several coverages. Initial, peak, and rolling drawbar pull values showed consistent increases with continued traffic.
- e. Mat breaks. The number and types of mat breaks are given in table 1. Relatively few mat breaks occurred with most of these being rivet failures.

Item 2. The item was considered failed due to roughness at 700 coverages. The following information was obtained from traffic tests on item 1.

- a. Roughness. At failure the average transverse and diagonal differential deformations were 2.88 and 2.50 in., respectively (table 1). The average dishing of individual panels was 0.23 in. at failure.
- b. Deformation. Average cross-section deformations are shown in figure 18. The maximum average cross-section deformation at failure was 2.35 in. approximately 2 ft either side of the traffic lane center line. Profiles in figure 19 indicate the severe longitudinal deformations that existed in the item at failure, especially at the end adjacent to item 1.
- c. Deflection. Average elastic mat deflections are shown in figure 20. Table 1 shows elastic subgrade deflections beneath a load wheel for several coverage levels. Elastic subgrade deflection at failure was 0.70 in.
- d. Rolling resistance. Initial, peak, and rolling drawbar pull values increased with traffic coverage. Table 1 gives drawbar values for various coverages through the 700-coverage level.
- e. Mat breaks. The number and types of mat breaks are given in table 1. There were relatively few mat breaks at failure.

Item 3. Item 3 was considered failed at 200 coverages due to roughness. The following information was obtained from traffic tests on item 3.

- a. Roughness. At failure, the average transverse and diagonal differential deformations were 4.16 and 4.41 in., respectively (table 1). The average rut depth at failure was 3.28 in.
- b. Deformation. Average cross-section deformations at 40 and 200

Contrails

coverages are shown in figure 18. Considerable rutting developed between the two coverage levels. Figure 19 shows profiles for 40 and 200 coverages and illustrates the progressive subsidence of the item with traffic.

- c. Deflection. Total subgrade deflections are shown in figure 20 for 0, 40, and 200 coverages. Maximum deflection occurred at 40 coverages. Elastic subgrade deflections shown in table 1 decreased with traffic.
- d. Rolling resistance. Consistent increases in initial, peak, and rolling drawbar pull were measured as coverage levels increased (table 1).

Lane 29

Behavior of items under traffic

Item 1. Item 1 prior to traffic is shown in figure 9. The item was considered failed at 140 coverages due to roughness (figure 10). As trafficking continued, the subgrade was laterally displaced from the lane center line resulting in subgrade subsidence and consequent mat standoff, or bridging, of approximately 2.5 in. with noticeable effect on measured deformation and deflection. The rated CBR was 1.8.

Item 2. Item 2 prior to traffic is shown in figure 11. The item was considered failed at 200 coverages due to roughness (figure 12). The rated CBR was 2.8.

Item 3. Item 3 prior to traffic is shown in figure 13. The item was considered failed at 200 coverages due to roughness (figure 14). The rated CBR was 4.5.

Test results

Results of trafficking lane 29 are summarized in table 1. Soil test data are given in table 2. Table 1 contains drawbar pull values for the load vehicle operated over an asphalt-paved strip for comparison with drawbar values recorded on the test lane.

Item 1. Item 1 was considered failed at 140 coverages. The following information was obtained from traffic tests on item 1.

- a. Roughness. At failure, the average transverse and diagonal differential deformations were 1.62 and 1.75 in., respectively (table 1). Dishing averaged 0.40 in.
- b. Deformation. Average cross-section and profile deformations are

Contrails

shown in figures 18 and 19, respectively. The maximum average cross-section deformation was +1.9 in. and occurred along the west side of the lane. This positive deformation was due to lateral displacement of the subgrade under traffic. Figure 19 shows deformations at 42 and 140 coverages. Displacement and subsidence of the subgrade under traffic caused bridging of the mat surface and consequently a number of positive deformation readings were recorded at 140 coverages.

- c. Deflections. Deflections shown in figure 20 increased consistently with traffic. The large deflection measurements were due to the mat standoff effect resulting from subsidence of the subgrade. Elastic subgrade deflection at failure was 2.2 in. (table 1).
- d. Rolling resistance. Initial, peak, and rolling drawbar pull values at several coverage levels are shown in table 1. Rolling and peak drawbar pull increased consistently with traffic, while initial drawbar pull decreased slightly at 140 coverages.
- e. Mat breaks. Number of breaks by type are shown in table 1. There were a large number of rivet failures at 140 coverages.

Item 2. Item 2 was considered failed due to roughness at 200 coverages. The following information was obtained from traffic tests on item 2.

- a. Roughness. At failure, the average transverse and diagonal differential deformations were 3.53 and 3.60 in., respectively (table 1). Dishing of individual panels was insignificant.
- b. Deformations. Average cross-section deformations at 42, 140, and 200 coverages are shown in figure 18 for the two typical mat runs. The magnitude of deformations at 140 and 200 coverages is approximately the same, with both showing large increases over the 42-coverage values. Profiles along the item are shown in figure 19 for 42, 140, and 200 coverages. Very consistent increases in profile deformations occurred with traffic. The most severe deformation occurred at the south end of the item adjacent to the previously failed item 1.
- c. Deflection. Average elastic mat deflections for three positions of the wheel assembly relative to mat joints are plotted in figure 20. Deflections did not vary greatly at the different coverage levels shown. Elastic subgrade deflection at failure was 1.50 in. (table 1).
- d. Rolling resistance. Drawbar pull values increased with traffic (table 1). Rolling drawbar pull showed the greatest relative increase, going from 2.9 kips prior to traffic to 4.8 kips at failure.
- e. Mat breaks. No mat breaks were evident at failure of the item.

Contrails

Item 3. Item 3 was considered failed at 200 coverages. The following information was obtained from traffic tests on item 3.

- a. Roughness. Average transverse and diagonal differential deformations were 5.10 and 5.13 in., respectively, at failure (table 1). No rut depth measurements were made at failure because the close spacing of the tracking tires made individual ruts indistinguishable.
- b. Deformation. Average cross-section deformations for 42, 140, and 200 coverages are shown in figure 18. Deformations became increasingly severe with traffic, reaching 4.0 in. at failure. Figure 19 shows profile deformations for the same coverage levels, illustrating the very large increase that occurred between 140 and 200 coverages, especially on the end adjacent to mat-surfaced item 2.
- c. Deflection. Total subgrade deflections shown in figure 20 somewhat erratic at intermediate coverage levels but yielded greatest values at failure. Table 1 shows elastic subgrade deflections with a value of 0.65 in. at failure.
- d. Rolling resistance. Drawbar pull values increased steadily with traffic (table 1). Rolling drawbar pull registered the greatest relative increase.

Contrails

SECTION V: PRINCIPAL FINDINGS

From the foregoing discussion, the principal findings relating test load, wheel assembly, tire inflation pressure, surface type, subgrade CBR, and traffic coverages are as follows:

<u>Load, Wheel Assembly, and Tire Pressure</u>	<u>Type of Surface</u>	<u>Rated Subgrade CBR</u>	<u>Coverages at Failure</u>
70,000-lb load; twin-wheel assembly (58.5 in. c-c*); 25.00x28, 30-ply tires in- flated to 50 psi	Modified T11 aluminum mat	2.1	700
	M8 steel mat	2.8	700
	Unsurfaced	4.7	200
70,000-lb load; twin-wheel assembly (29.5 in. c-c); 25.00x28, 30-ply tires in- flated to 50 psi	Modified T11 aluminum mat	1.8	140
	M8 steel mat	2.8	200
	Unsurfaced	4.5	200

* Because of tracking equipment difficulties, it was necessary to respace wheels at 56 in. c-c at 550 coverages before continuing traffic.

Contrails

TABLE 1
SUMMARY OF TRAFFIC DATA, TEST SECTION 13

Test item	Cover-ages	Rated CBR	No. of Mat Breaks*			Differential Trans-verse Deformation (in.)						Dishing or Rutting (in.)				Average Total Deflection (in.) with Center Line of Assembly Located on				Elastic Subgrade Deflection (in.)	Remarks		
						Longi-tudinal			Diagonal			Max. Ave.		Max. Ave.		Quarter of Panel		Center of Panel				Joint of Panel	
						Max.	Ave.	Min.	Max.	Ave.	Min.	Max.	Ave.	Max.	Ave.	Max.	Ave.	Max.	Ave.			Max.	Ave.
1 Modified T11 aluminum landing mat	0	1.8	4	2	4	0.50	0.35	0.63	0.41	0.63	0.50	0.25	0.25	1.60	1.30	1.60	1.10	1.60	1.10	1.60	1.10	Failed at 700 coverages due to elastic deflection	
	20	1.8	4	2	4	0.63	0.44	0.75	0.60	0.75	0.60	0.25	0.25	1.60	1.55	1.65	1.50	1.65	1.50	1.65	1.30		
	40	1.8	4	2	4	0.63	0.50	1.00	0.63	1.00	0.66	0.38	0.38	2.40	1.90	2.60	2.10	2.80	2.20	2.80	2.20		
	100	2.1	4	3	4	0.75	0.66	0.75	0.69	1.13	0.72	0.38	0.32	3.30	2.20	3.30	2.85	3.80	3.15	3.80	3.15	1.30	
	200	2.1	4	3	4	1.25	1.03	1.25	1.16	1.25	1.19	0.25	0.25	3.60	2.70	3.60	3.30	4.10	3.80	4.10	3.80	1.10	
	260	2.1	4	3	4	1.57	1.09	1.63	1.35	1.88	1.54	0.50	0.38	1.10	0.50	1.00	0.50	1.00	0.50	1.00	0.50	1.00	0.85
	360	2.1	4	3	4	0.38	0.32	0.50	0.37	0.63	0.47	0.25	0.25	1.00	0.50	1.00	0.60	0.90	0.15	0.83	0.15	0.83	0.65
	550	2.1	4	3	4	0.38	0.32	0.63	0.50	0.88	0.72	0.25	0.18	1.30	0.45	1.30	0.80	1.30	0.45	0.63	0.45	0.63	0.70
	680	2.1	4	3	4	0.50	0.38	1.13	0.78	1.00	0.63	0.25	0.18	1.50	0.45	1.50	0.60	1.00	0.60	1.00	0.60	1.00	0.70
	700	2.1	4	3	4	0.25	0.22	1.50	1.22	1.13	1.10	0.25	0.16	1.50	0.45	1.50	0.60	1.00	1.00	1.00	1.00	1.00	0.70
2 MS steel landing mat	0	4.7	13	7	9	1.00	0.78	2.00	1.75	2.13	1.72	0.25	0.22	1.50	0.60	1.00	1.00	1.00	1.00	1.00	1.00	Failed at 700 coverages due to roughness	
	20	4.7	13	7	9	1.00	0.94	3.00	2.88	2.75	2.50	0.38	0.23	1.50	0.60	1.00	1.00	1.00	1.00	1.00	1.00	0.70	
	40	4.7	13	7	9	0.38	0.32	1.50	1.38	1.63	1.50	0.25	0.25	1.50	0.60	1.00	1.00	1.00	1.00	1.00	1.00	0.70	
	100	4.7	13	7	9	0.50	0.44	2.75	2.06	2.75	2.06	1.25	1.19	1.50	0.60	1.00	1.00	1.00	1.00	1.00	1.00	1.00	0.60
	180	4.7	13	7	9	0.75	0.60	3.13	2.47	3.75	2.88	1.38	1.16	1.50	0.60	1.00	1.00	1.00	1.00	1.00	1.00	1.00	0.60
	200	4.7	13	7	9	1.50	0.97	4.75	4.10	5.25	4.47	4.13	3.10	1.50	0.60	1.00	1.00	1.00	1.00	1.00	1.00	1.00	0.20
	260	4.7	13	7	9	1.88	1.63	4.75	4.16	5.25	4.41	4.13	3.28	1.50	0.60	1.00	1.00	1.00	1.00	1.00	1.00	1.00	0.20
3 Asphalt strip	0	1.8	22	11	16	1.00	0.44	1.68	1.25	1.38	1.10	0.25	0.25	1.60	1.50	1.30	1.20	1.60	1.20	1.60	1.20	Failed at 140 coverages due to roughness	
	42	1.8	22	11	16	1.38	0.98	0.88	0.73	1.44	1.10	0.50	0.38	1.60	1.50	1.30	1.20	1.60	1.20	1.60	1.20	0.97	
	70	1.8	22	11	16	1.38	0.98	0.88	0.73	1.44	1.10	0.50	0.38	1.60	1.50	1.30	1.20	1.60	1.20	1.60	1.20	0.97	
	84	1.8	22	11	16	1.38	0.98	0.88	0.73	1.44	1.10	0.50	0.38	1.60	1.50	1.30	1.20	1.60	1.20	1.60	1.20	0.97	
	98	1.8	22	11	16	1.88	1.44	1.50	1.16	1.75	1.41	0.58	0.40	3.50	3.40	4.20	3.90	3.80	3.70	2.20	2.20	0.97	
	140	1.8	22	11	16	1.50	1.22	2.13	1.62	2.25	1.75	0.58	0.40	1.40	1.40	1.40	1.40	1.40	1.40	1.40	1.40	1.40	0.97
	200	1.8	22	11	16	1.00	0.44	1.68	1.25	1.38	1.10	0.25	0.25	1.40	1.40	1.40	1.40	1.40	1.40	1.40	1.40	1.40	0.97
	42	1.8	22	11	16	0.75	0.56	1.63	1.28	1.63	1.35	0.25	0.25	1.40	1.40	1.40	1.40	1.40	1.40	1.40	1.40	1.40	0.97
	70	1.8	22	11	16	0.63	0.50	2.88	2.34	3.50	2.28	0.25	0.25	1.40	1.40	1.40	1.40	1.40	1.40	1.40	1.40	1.40	0.97
	84	1.8	22	11	16	0.88	0.56	3.75	3.41	5.50	3.35	0.25	0.25	1.40	1.40	1.40	1.40	1.40	1.40	1.40	1.40	1.40	0.97
Unsurfaced	0	4.5	13	7	9	1.75	0.97	4.00	3.53	3.88	3.60	0.25	0.25	1.50	1.30	1.40	1.40	1.40	1.40	1.40	1.40	Failed at 200 coverages due to roughness	
	42	4.5	13	7	9	0.50	0.25	1.88	1.63	1.98	1.75	1.50	1.10	1.50	1.30	1.40	1.40	1.40	1.40	1.40	1.40	0.30	
	70	4.5	13	7	9	0.50	0.25	1.88	1.63	1.98	1.75	1.50	1.10	1.50	1.30	1.40	1.40	1.40	1.40	1.40	1.40	0.60	
	84	4.5	13	7	9	0.50	0.25	1.88	1.63	1.98	1.75	1.50	1.10	1.50	1.30	1.40	1.40	1.40	1.40	1.40	1.40	0.60	
	98	4.5	13	7	9	2.63	1.75	2.63	1.53	1.50	1.10	1.50	1.10	1.50	1.30	1.40	1.40	1.40	1.40	1.40	1.40	0.45	
	140	4.5	13	7	9	2.63	1.75	2.63	1.53	1.50	1.10	1.50	1.10	1.50	1.30	1.40	1.40	1.40	1.40	1.40	1.40	0.45	
	200	4.5	13	7	9	0.88	0.72	4.88	4.44	4.63	4.28	0.25	0.25	1.50	1.30	1.40	1.40	1.40	1.40	1.40	1.40	1.40	0.65

Note: For trafficking both lanes, a 70-kip load was used on a twin-wheel assembly with 25,000-lb, 30-ply tires inflated to 50 psi. The wheel spacings were 56.5 in. c-c and 29.5 in. c-c for lanes 28 and 29, respectively.
* Mat breaks are described and illustrated in Part I.

Contrails

TABLE 2
SUMMARY OF CBR, DENSITY, AND WATER CONTENT DATA, TEST SECTION 13

Test Item*	Type of Surface	No. of Traffic Coverages	Depth (in.)	CBR	Water Content, %	Dry Density (lb/cu ft)		
<u>Lane 28</u>								
1	Modified T11 aluminum landing mat	0	0	1.4	33.2	86.2		
			6	1.5	34.7	83.0		
			12	1.6	32.6	86.7		
			18	1.6	33.9	85.5		
		550	0	3.0	30.0	89.9		
			6	1.7	34.6	85.0		
			12	2.1	33.6	85.8		
			18	1.6	34.5	85.6		
		700	0	2.7	33.2	86.4		
			6	2.5	33.2	86.1		
			12	2.8	33.1	85.9		
			18	3.4	32.1	88.7		
2	M8 steel landing mat	0	0	1.3	31.6	85.8		
			6	2.4	29.4	88.9		
			12	2.7	27.7	89.7		
			18	4.4	27.1	91.9		
		550	0	3.3	30.3	90.6		
			6	2.5	30.5	90.6		
			12	2.7	28.6	91.5		
			18	3.1	30.3	89.6		
		700	0	3.0	30.3	90.0		
			6	3.4	30.3	90.0		
			12	3.7	28.4	93.0		
			18	4.6	29.9	89.7		
3	Unsurfaced	0	0	4.5	28.4	91.2		
			6	5.1	25.6	90.7		
			12	5.1	27.7	92.6		
			18	5.5	27.2	94.4		
		200	0	3.9	28.1	93.7		
			6	4.7	27.9	92.9		
			12	5.1	27.5	93.3		
			18	5.6	28.0	91.9		
		<u>Lane 29</u>						
		1	Modified T11 aluminum landing mat	0	0	1.2	33.9	83.8
					6	1.1	33.2	84.5
					12	1.5	33.2	85.7
18	1.0				36.1	81.3		
140	0			2.2	33.4	85.2		
	6			2.4	33.1	86.3		
	12			2.5	34.0	84.8		
	18			2.8	31.0	89.2		
2	M8 steel landing mat			0	0	3.0	28.2	91.0
					6	2.3	29.1	90.5
					12	2.0	31.6	89.8
					18	2.4	31.6	87.5
		140	0	2.3	30.7	90.6		
			6	3.3	30.3	89.6		
			12	3.7	29.3	91.2		
			18	2.8	29.6	91.1		
		200	0	2.5	30.9	89.6		
			6	2.3	29.0	91.3		
			12	3.4	28.0	93.1		
			18	2.5	30.1	90.5		
3	Unsurfaced	0	0	4.5	27.4	93.0		
			6	4.7	27.5	94.0		
			12	4.7	28.9	90.5		
			18	5.6	26.0	94.5		
		140	0	5.0	27.5	92.9		
			6	4.9	25.8	95.8		
			12	4.1	28.5	91.8		
			18	5.3	26.6	95.3		
		200	0	4.0	27.6	94.4		
			6	3.2	29.1	92.2		
			12	4.3	28.4	92.6		
			18	4.9	27.0	93.8		

Note: For coverage-failure information, see remarks column in table 1.
* Subgrade material was heavy clay (classified as CH) in all items.



Figure 2. Load vehicle

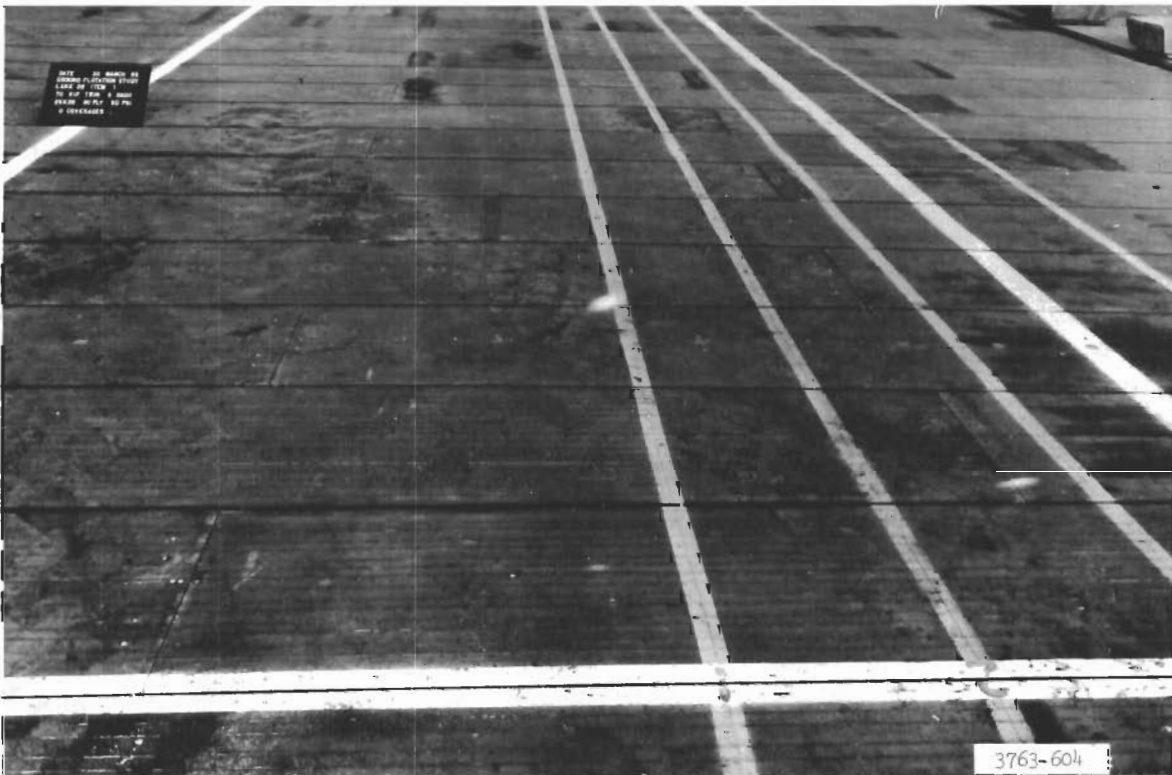

Figure 3. Lane 28, item 1, prior to traffic



Figure 4. Lane 28, item 1, after 700 coverages of traffic (failure)

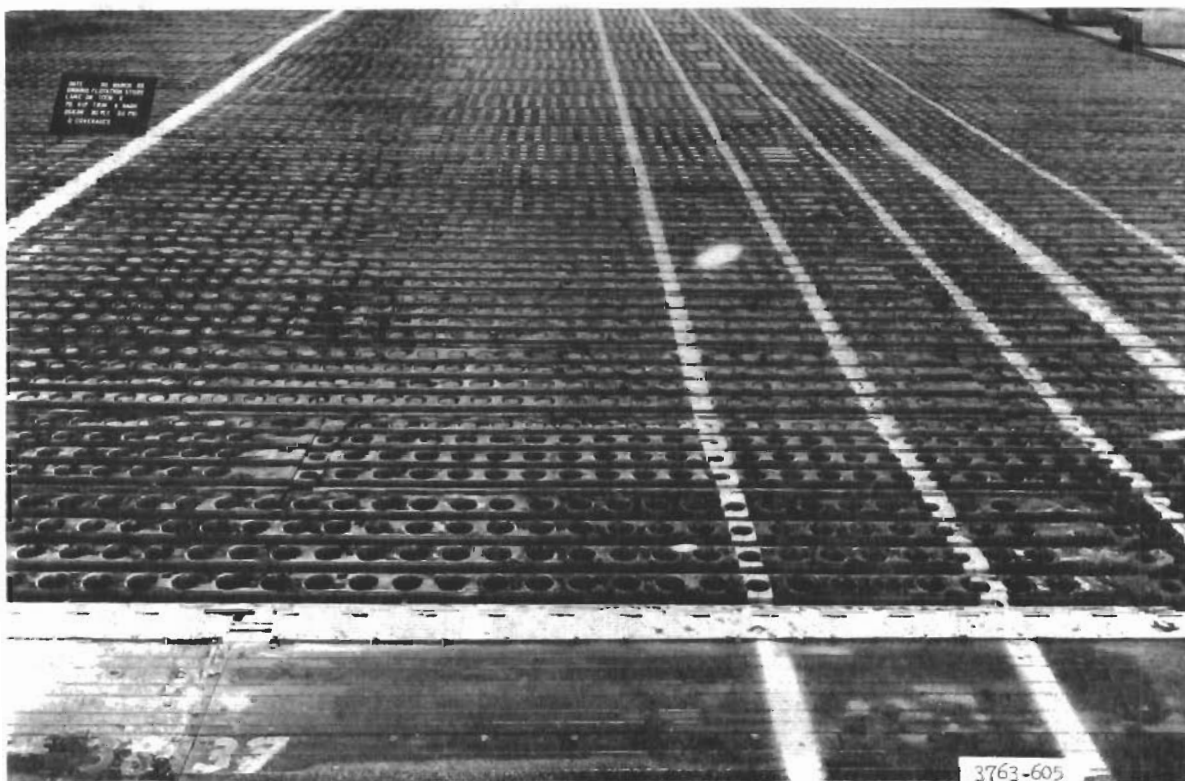

Figure 5. Lane 28, item 2, prior to traffic

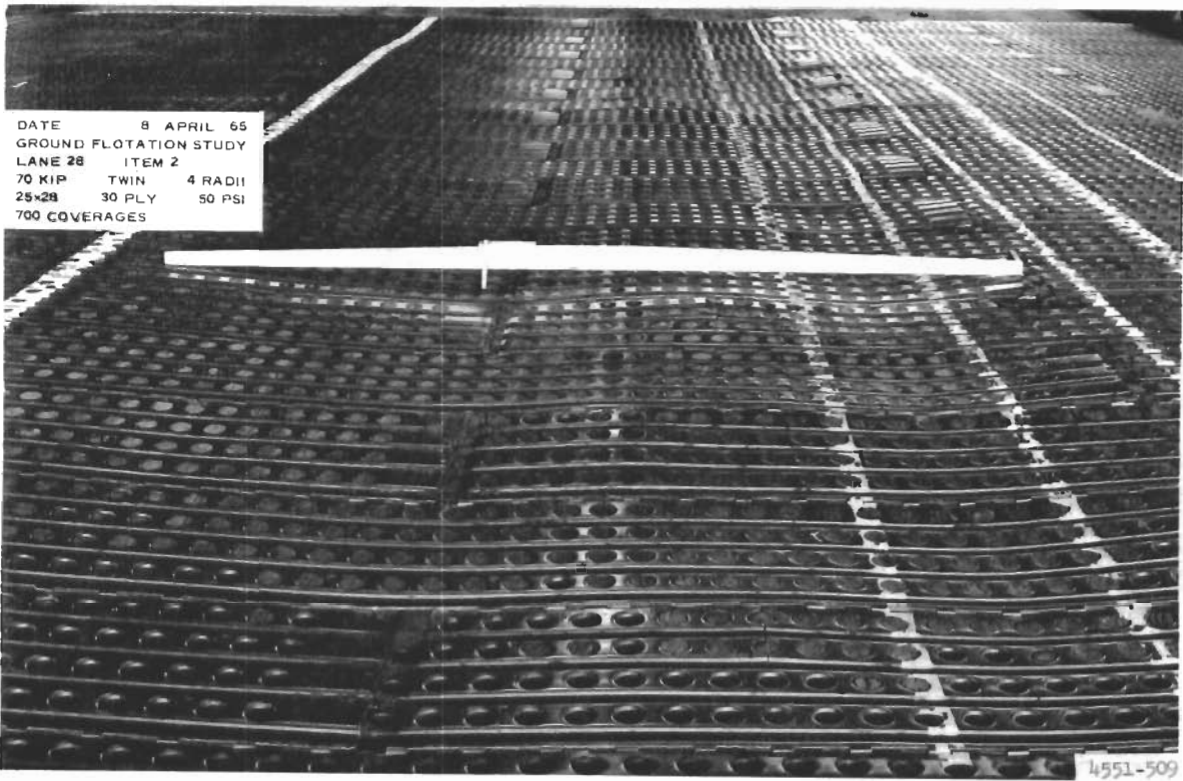

Figure 6. Lane 28, item 2, after 700 coverages of traffic (failure)

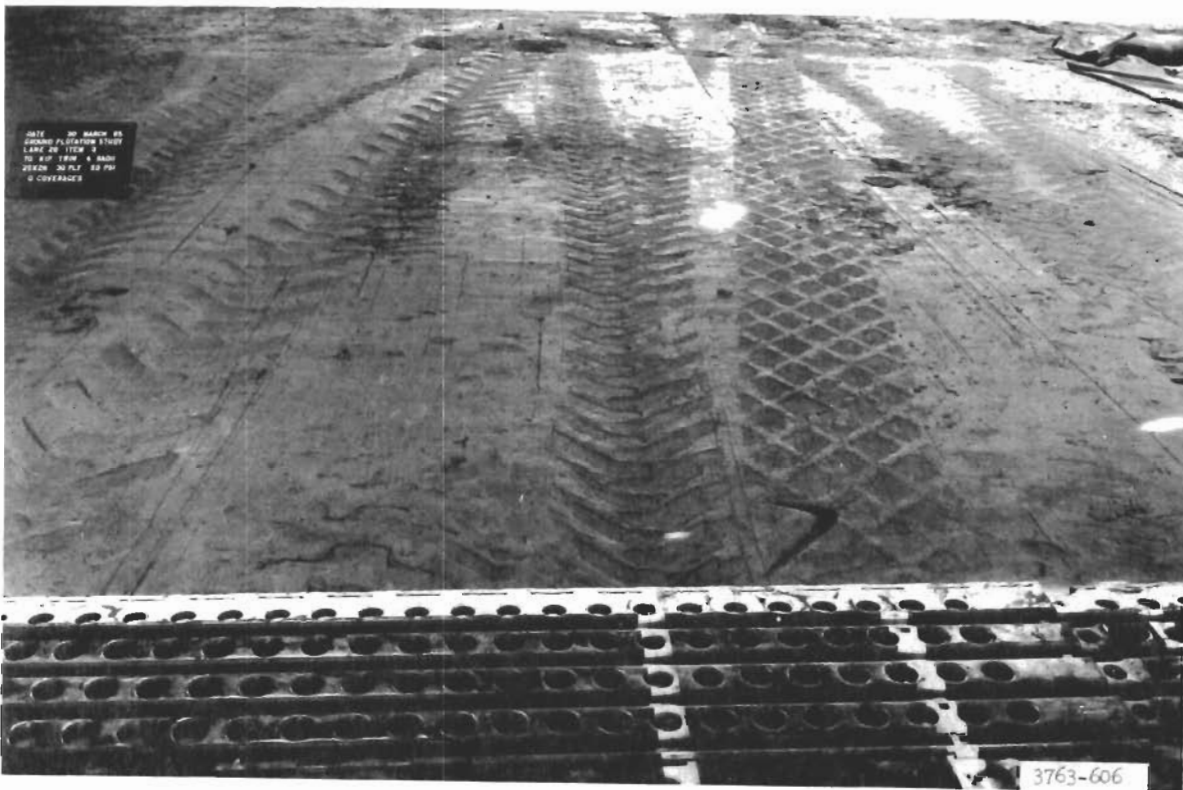

Figure 7. Lane 28, item 3, prior to traffic



Figure 8. Lane 28, item 3, after 200 coverages of traffic (failure)



Figure 9. Lane 29, item 1, prior to traffic

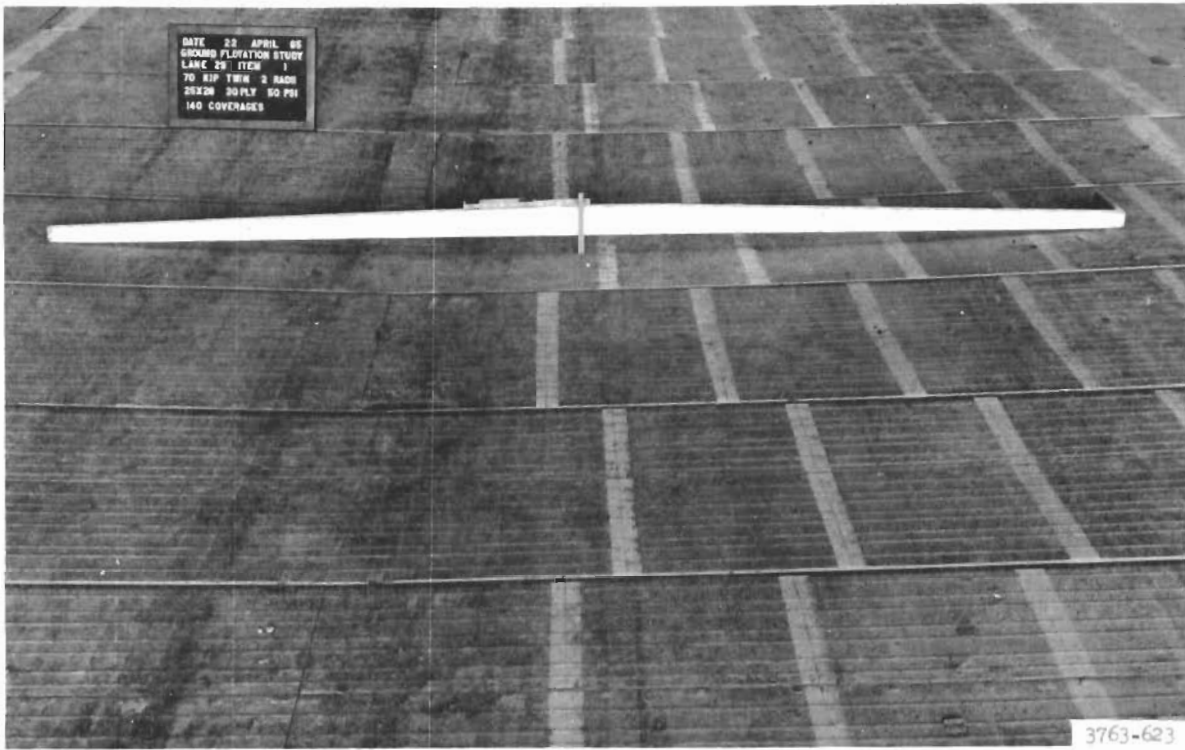

Figure 10. Lane 29, item 1, after 140 coverages of traffic (failure)

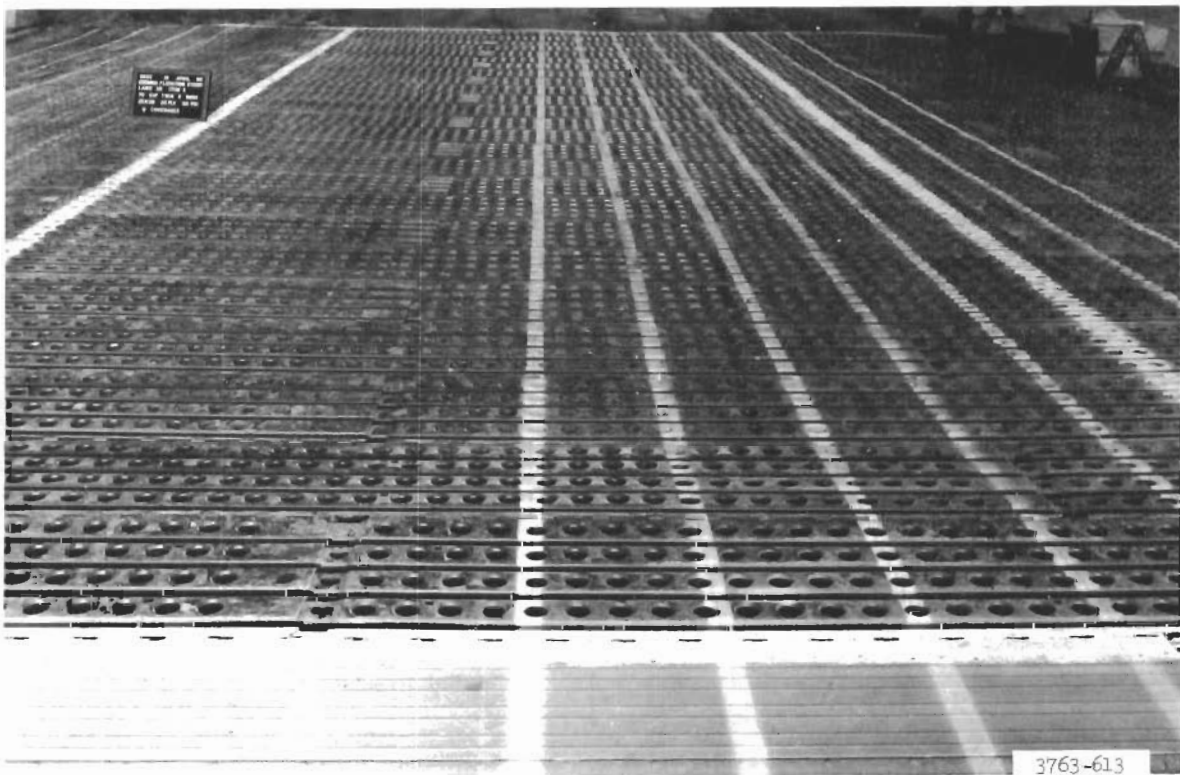

Figure 11. Lane 29, item 2, prior to traffic

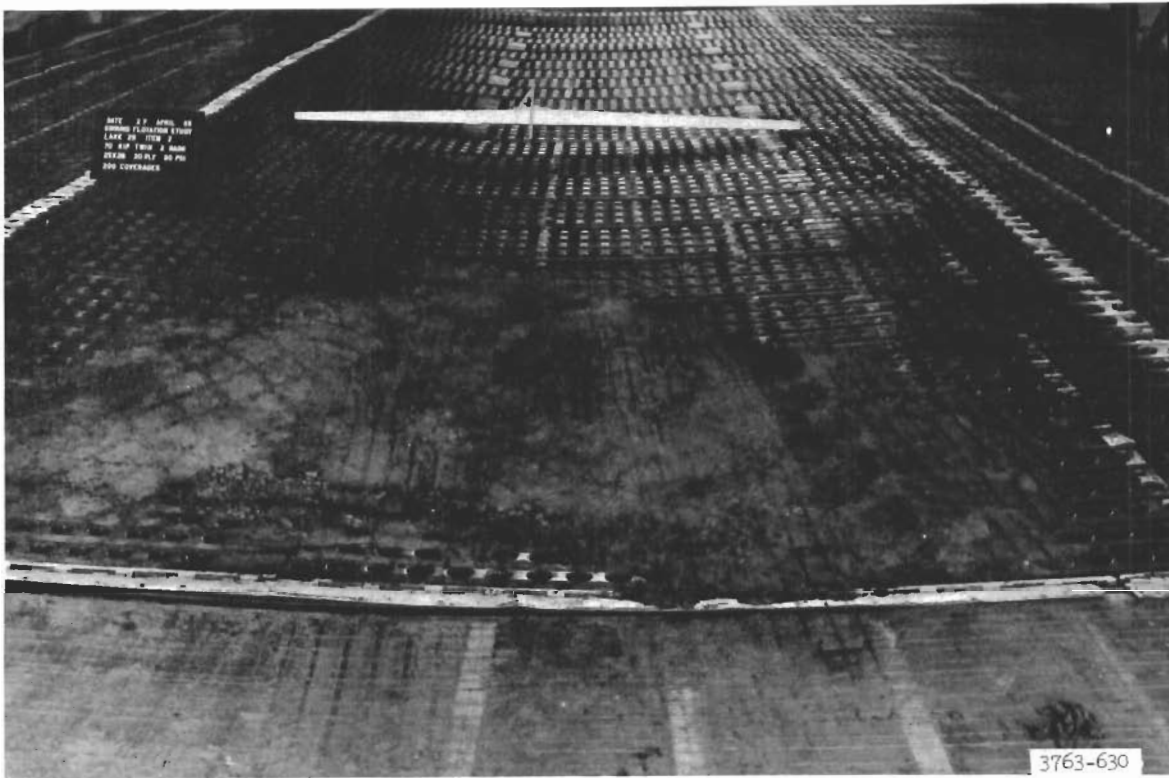

Figure 12. Lane 29, item 2, after 200 coverages of traffic (failure)

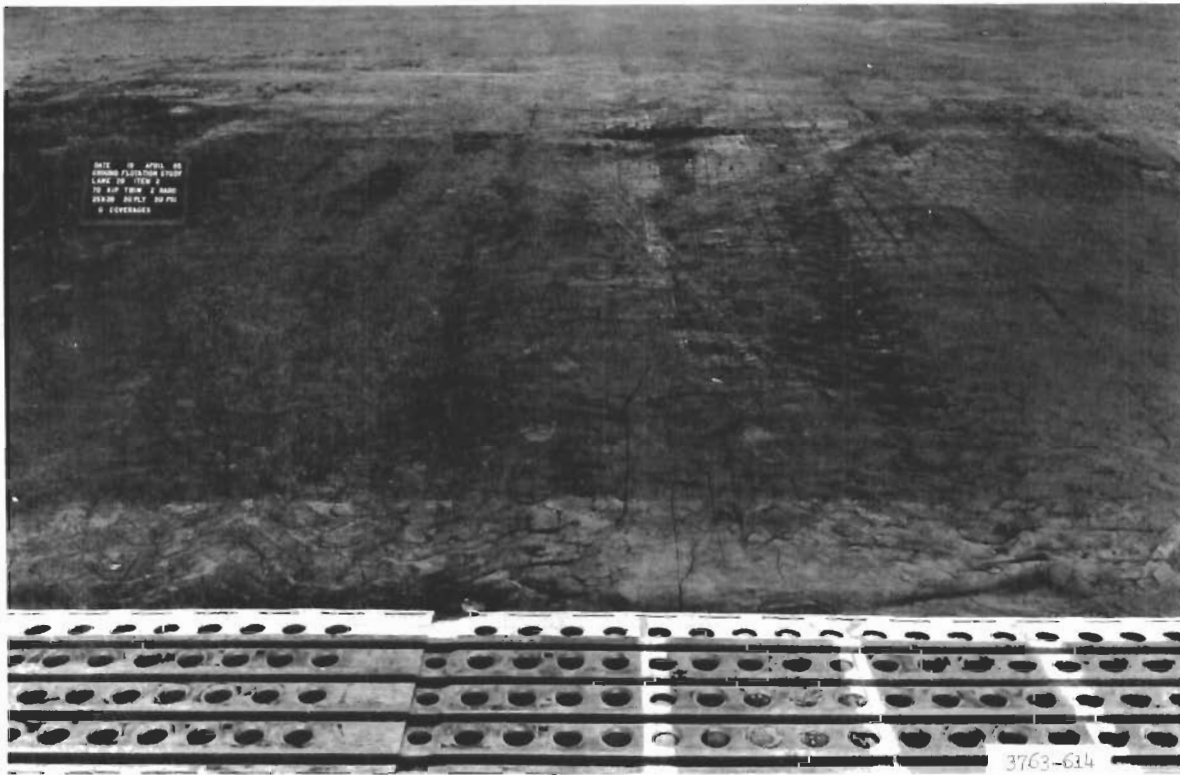

Figure 13. Lane 29, item 3, prior to traffic

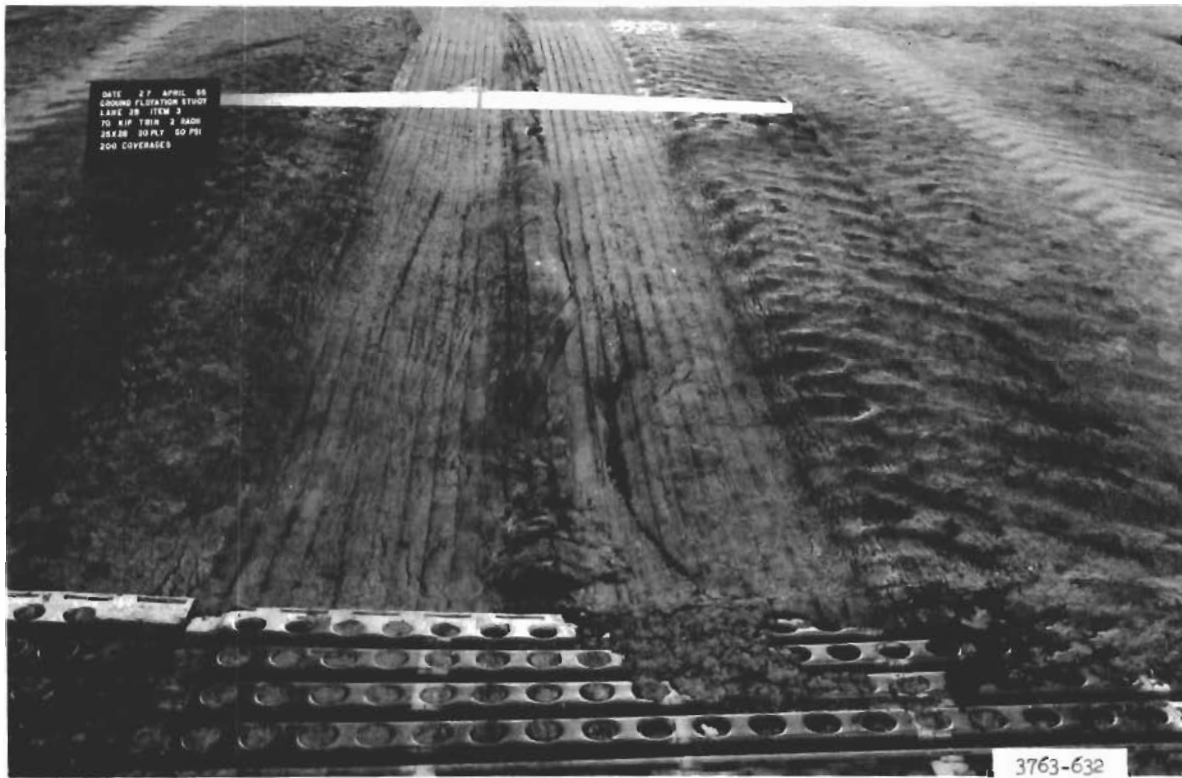
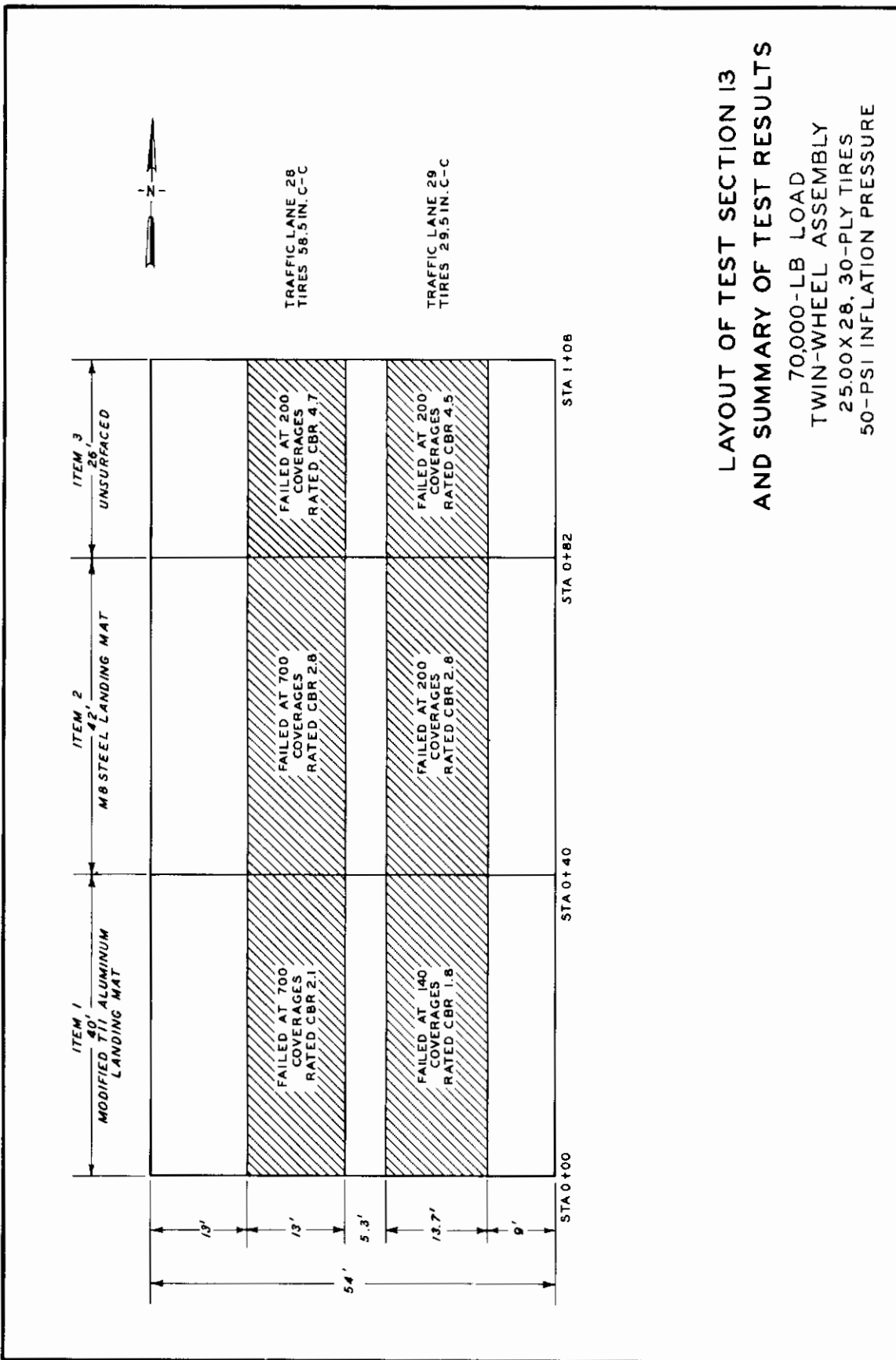

Figure 14. Lane 29, item 3, after 200 coverages of traffic (failure)



LAYOUT OF TEST SECTION 13
AND SUMMARY OF TEST RESULTS

70,000-LB LOAD
TWIN-WHEEL ASSEMBLY
2500 X 28, 30-PLY TIRES
50-PSI INFLATION PRESSURE

Figure 15

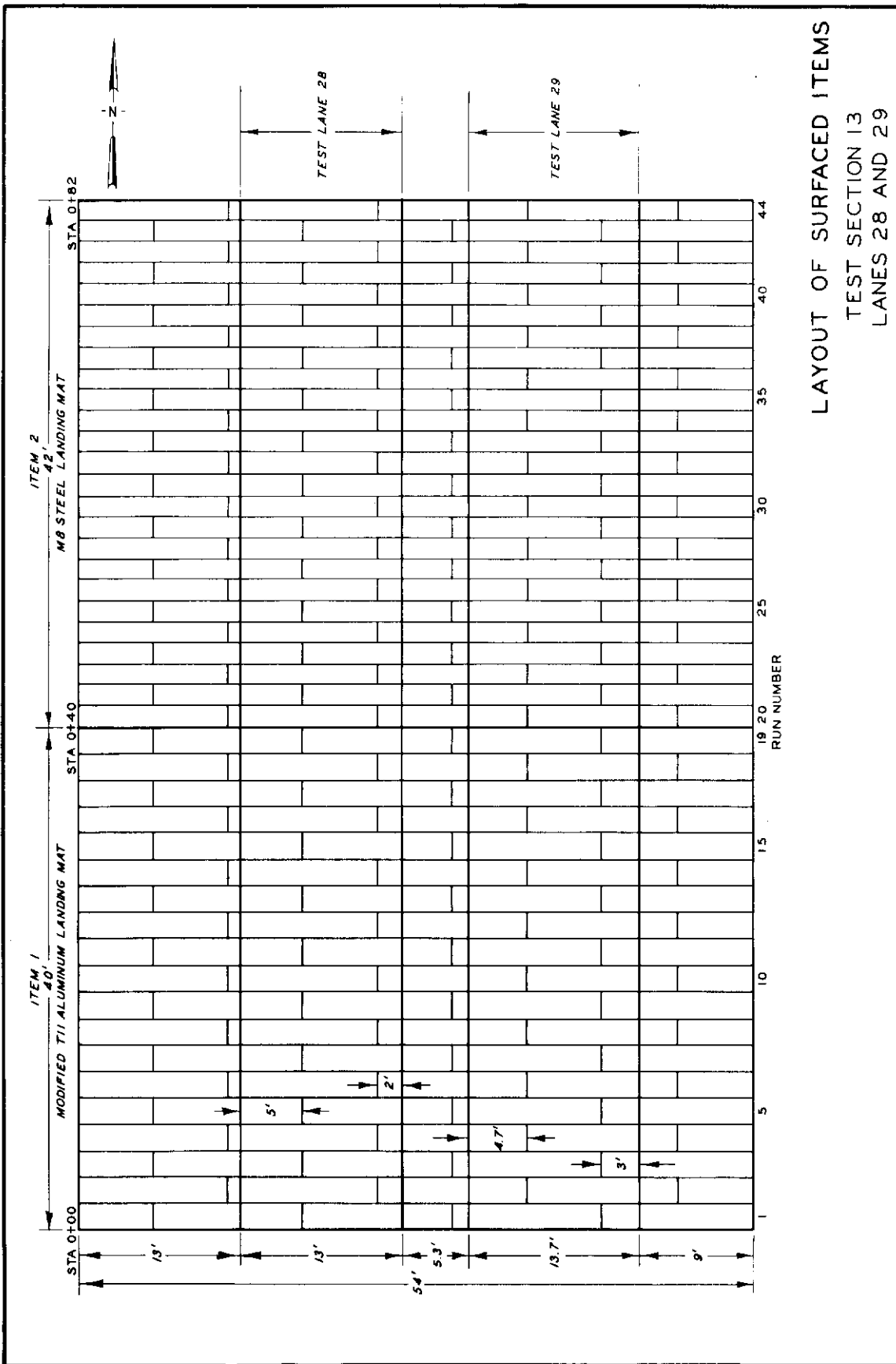

LAYOUT OF SURFACED ITEMS
 TEST SECTION 13
 LANES 28 AND 29

Figure 16

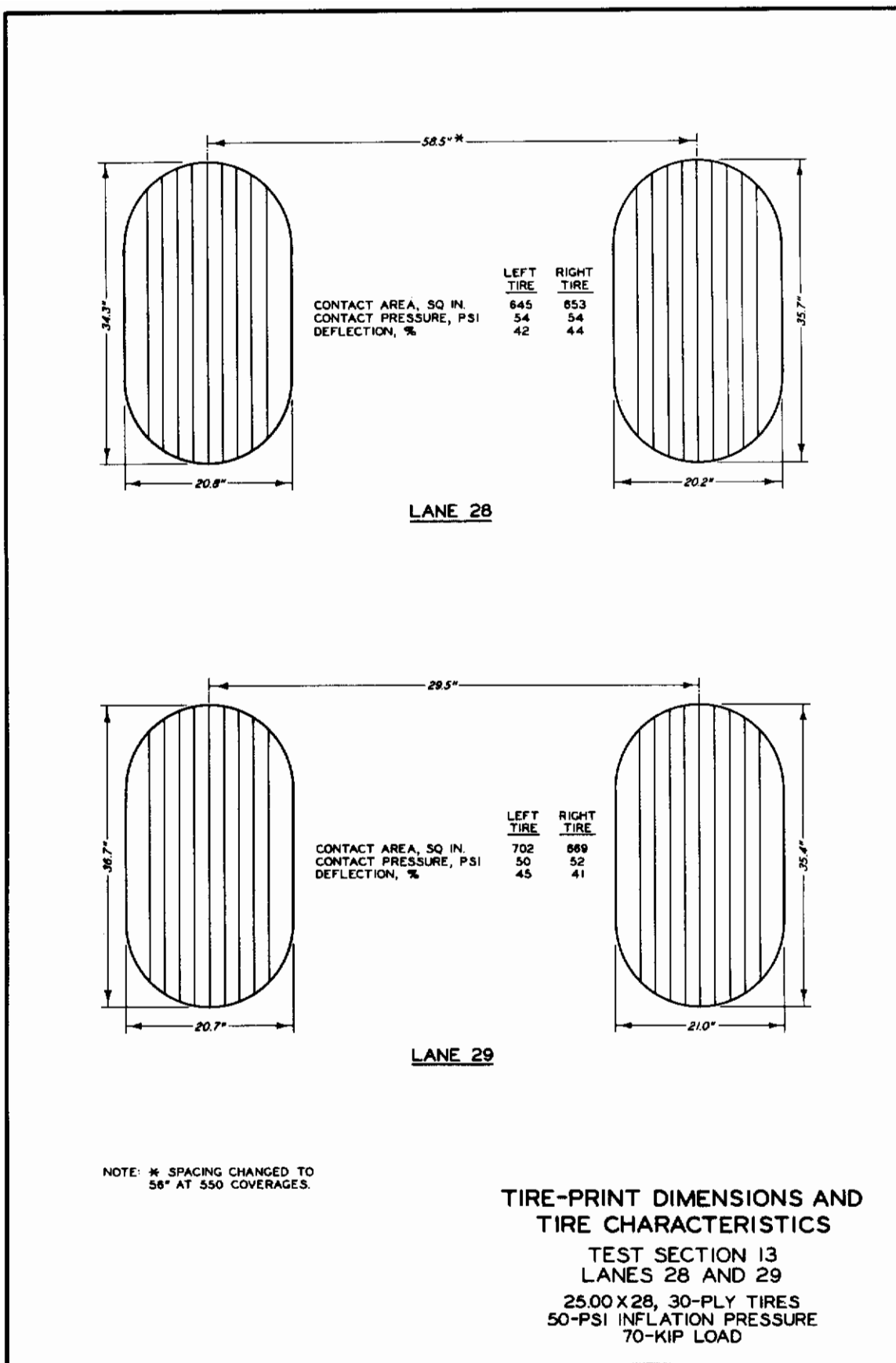

Figure 17

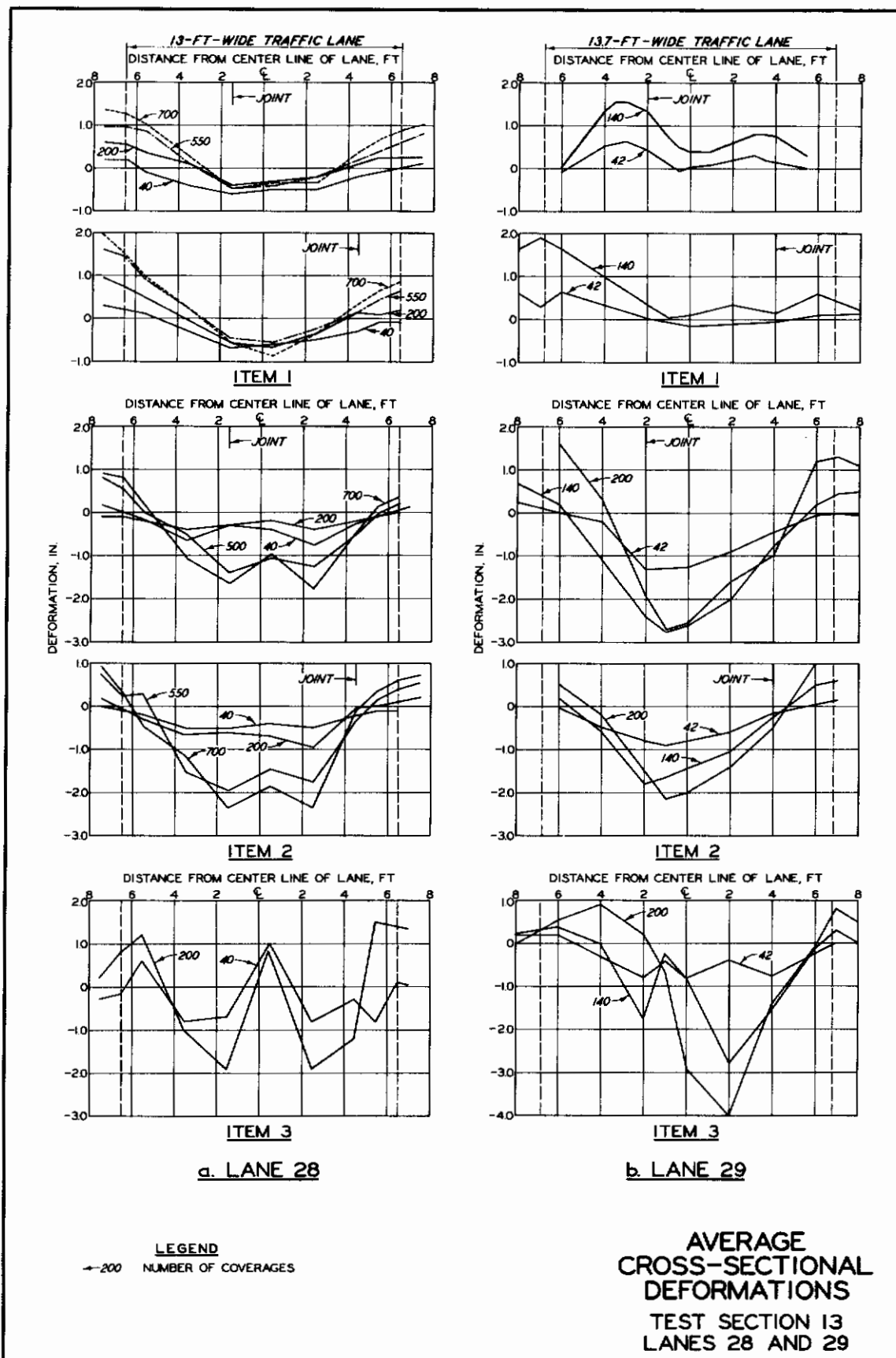

Figure 18

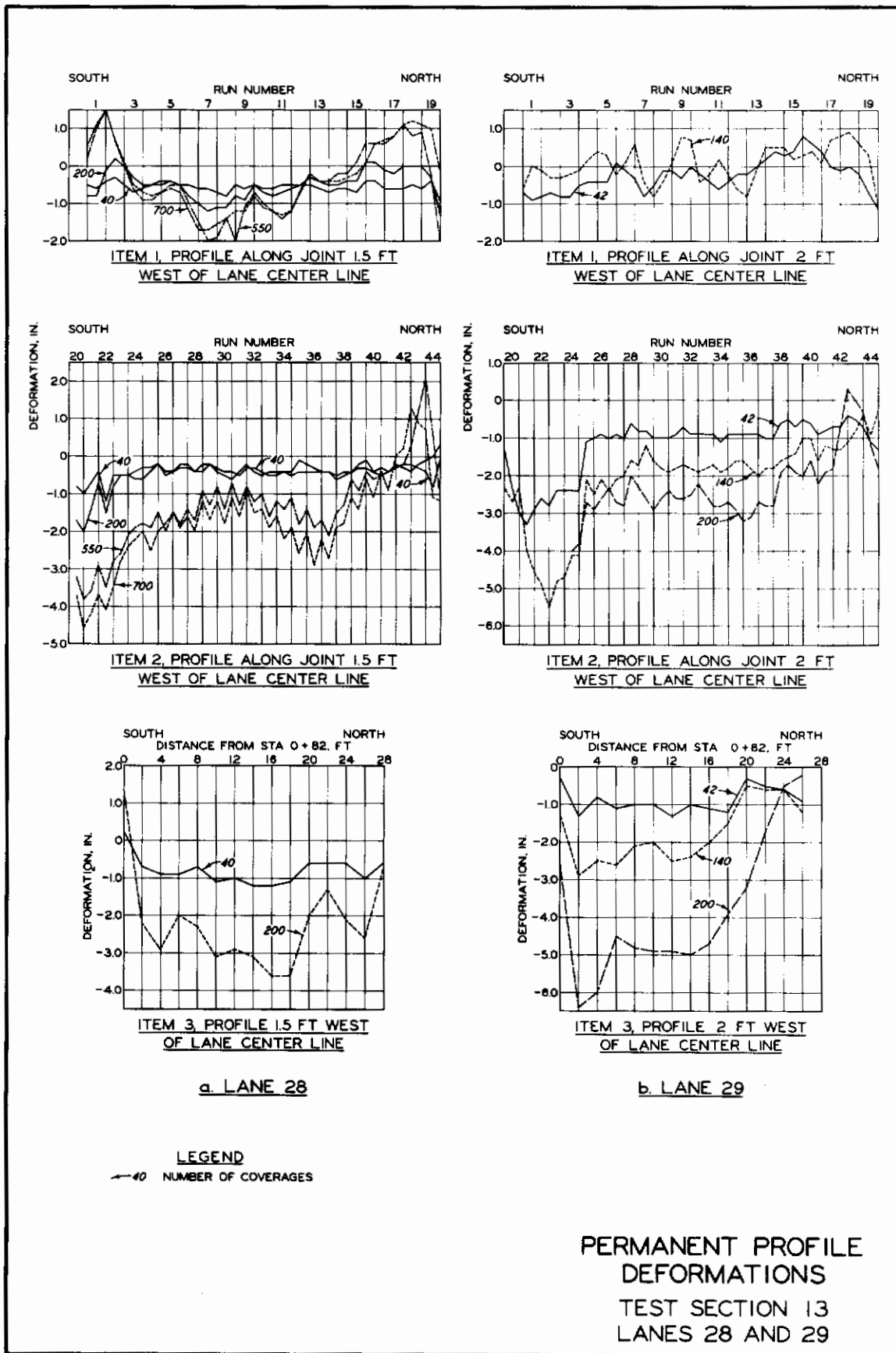

Figure 19

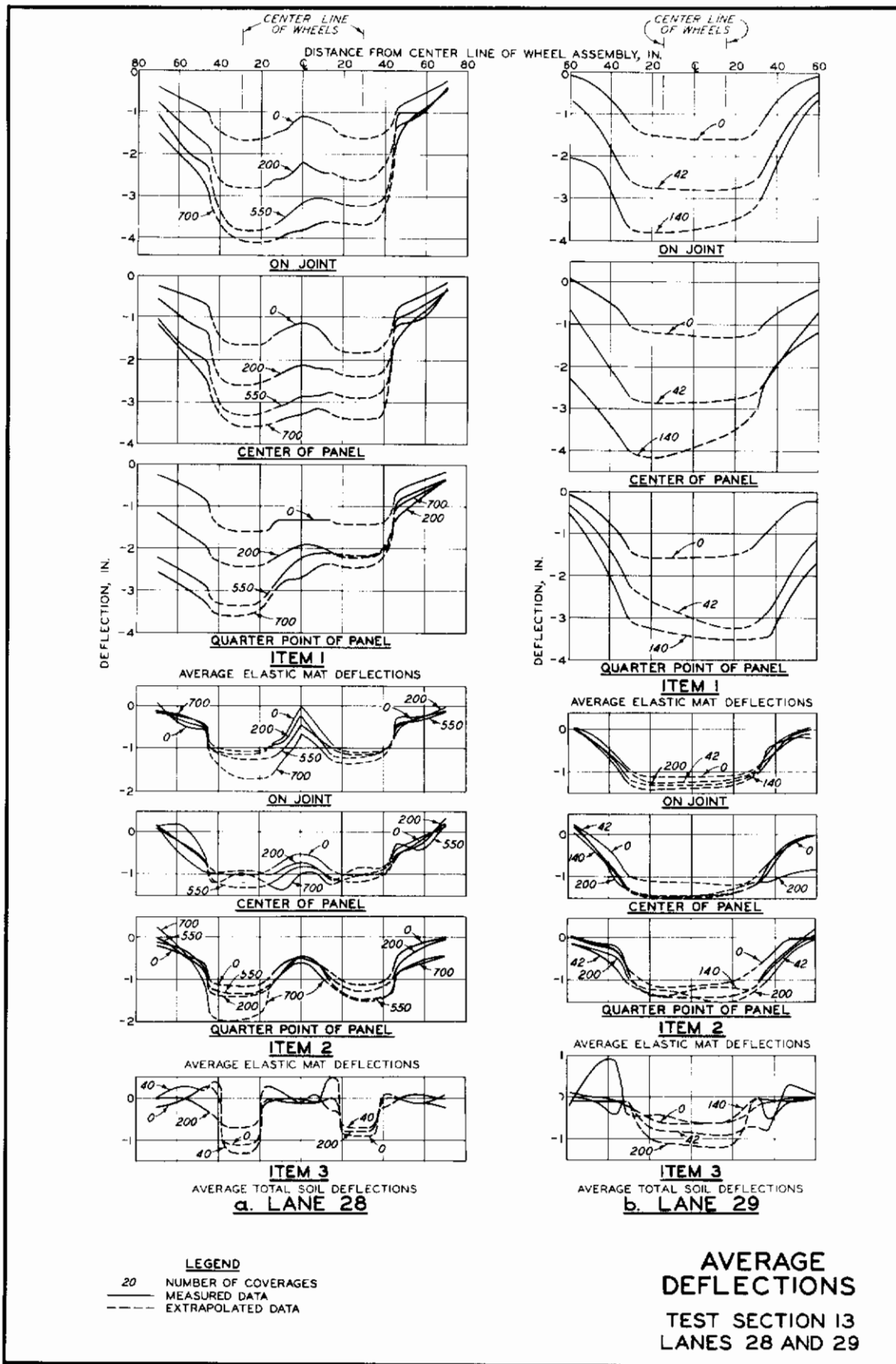

Figure 20

Contrails

UNCLASSIFIED
Security Classification

DOCUMENT CONTROL DATA - R&D		
<i>(Security classification of title, body of abstract and indexing annotation must be entered when the overall report is classified)</i>		
1. ORIGINATING ACTIVITY (Corporate author) U. S. Army Engineer Waterways Experiment Station	2a. REPORT SECURITY CLASSIFICATION UNCLASSIFIED	2b. GROUP
3. REPORT TITLE Aircraft Ground-Flotation Investigation Part XIII Data Report on Test Section 13		
4. DESCRIPTIVE NOTES (Type of report and inclusive dates) Final Technical Report		
5. AUTHOR(S) (Last name, first name, initial) Watkins, J. E. Hammitt, G. M., II		
6. REPORT DATE Sept 1966	7a. TOTAL NO. OF PAGES 27	7b. NO. OF REFS
8a. CONTRACT OR GRANT NO. MIPR AS-4-177	9a. ORIGINATOR'S REPORT NUMBER(S) AFFDL-TR-66-43, Part XIII	
b. PROJECT NO. 410A	9b. OTHER REPORT NO(S) (Any other numbers that may be assigned this report) None	
c.		
d.		
10. AVAILABILITY/LIMITATION NOTICES This document is subject to special export controls and each transmittal to foreign governments or foreign nationals may be made only with prior approval of the Air Force Flight Dynamics Laboratory, (FDF), Wright-Patterson AFB, Ohio 45433		
11. SUPPLEMENTARY NOTES	12. SPONSORING MILITARY ACTIVITY Air Force Flight Dynamics Laboratory Research and Technology Division AF Systems Command, WPAFB, Ohio	
13. ABSTRACT This data report describes the results of work undertaken as part of an overall program to develop ground-flotation criteria for the C-5A aircraft.		

DD FORM 1473
1 JAN 64

UNCLASSIFIED
Security Classification

14.	KEY WORDS	LINK A		LINK B		LINK C	
		ROLE	WT	ROLE	WT	ROLE	WT
	<p>Aircraft Ground Flotation Rolling Resistance Rear Area Airfields Support Area Airfields Forward Area Airfields Vehicle Mobility</p>						

INSTRUCTIONS

1. **ORIGINATING ACTIVITY:** Enter the name and address of the contractor, subcontractor, grantee, Department of Defense activity or other organization (*corporate author*) issuing the report.
- 2a. **REPORT SECURITY CLASSIFICATION:** Enter the overall security classification of the report. Indicate whether "Restricted Data" is included. Marking is to be in accordance with appropriate security regulations.
- 2b. **GROUP:** Automatic downgrading is specified in DoD Directive 5200.10 and Armed Forces Industrial Manual. Enter the group number. Also, when applicable, show that optional markings have been used for Group 3 and Group 4 as authorized.
3. **REPORT TITLE:** Enter the complete report title in all capital letters. Titles in all cases should be unclassified. If a meaningful title cannot be selected without classification, show title classification in all capitals in parenthesis immediately following the title.
4. **DESCRIPTIVE NOTES:** If appropriate, enter the type of report, e.g., interim, progress, summary, annual, or final. Give the inclusive dates when a specific reporting period is covered.
5. **AUTHOR(S):** Enter the name(s) of author(s) as shown on or in the report. Enter last name, first name, middle initial. If military, show rank and branch of service. The name of the principal author is an absolute minimum requirement.
6. **REPORT DATE:** Enter the date of the report as day, month, year, or month, year. If more than one date appears on the report, use date of publication.
- 7a. **TOTAL NUMBER OF PAGES:** The total page count should follow normal pagination procedures, i.e., enter the number of pages containing information.
- 7b. **NUMBER OF REFERENCES:** Enter the total number of references cited in the report.
- 8a. **CONTRACT OR GRANT NUMBER:** If appropriate, enter the applicable number of the contract or grant under which the report was written.
- 8b, 8c, & 8d. **PROJECT NUMBER:** Enter the appropriate military department identification, such as project number, subproject number, system numbers, task number, etc.
- 9a. **ORIGINATOR'S REPORT NUMBER(S):** Enter the official report number by which the document will be identified and controlled by the originating activity. This number must be unique to this report.
- 9b. **OTHER REPORT NUMBER(S):** If the report has been assigned any other report numbers (*either by the originator or by the sponsor*), also enter this number(s).
10. **AVAILABILITY/LIMITATION NOTICES:** Enter any limitations on further dissemination of the report, other than those

imposed by security classification, using standard statements such as:

- (1) "Qualified requesters may obtain copies of this report from DDC."
- (2) "Foreign announcement and dissemination of this report by DDC is not authorized."
- (3) "U. S. Government agencies may obtain copies of this report directly from DDC. Other qualified DDC users shall request through _____."
- (4) "U. S. military agencies may obtain copies of this report directly from DDC. Other qualified users shall request through _____."
- (5) "All distribution of this report is controlled. Qualified DDC users shall request through _____."

If the report has been furnished to the Office of Technical Services, Department of Commerce, for sale to the public, indicate this fact and enter the price, if known.

11. **SUPPLEMENTARY NOTES:** Use for additional explanatory notes.
12. **SPONSORING MILITARY ACTIVITY:** Enter the name of the departmental project office or laboratory sponsoring (*paying for*) the research and development. Include address.
13. **ABSTRACT:** Enter an abstract giving a brief and factual summary of the document indicative of the report, even though it may also appear elsewhere in the body of the technical report. If additional space is required, a continuation sheet shall be attached.

It is highly desirable that the abstract of classified reports be unclassified. Each paragraph of the abstract shall end with an indication of the military security classification of the information in the paragraph, represented as (TS), (S), (C), or (U).

There is no limitation on the length of the abstract. However, the suggested length is from 150 to 225 words.

14. **KEY WORDS:** Key words are technically meaningful terms or short phrases that characterize a report and may be used as index entries for cataloging the report. Key words must be selected so that no security classification is required. Identifiers, such as equipment model designation, trade name, military project code name, geographic location, may be used as key words but will be followed by an indication of technical context. The assignment of links, rules, and weights is optional.