

Contrails

AFFDL-TR-73-21-Vol. III
Book 1



STOL TACTICAL AIRCRAFT INVESTIGATION

VOLUME III + PERFORMANCE GROUND RULES AND METHODS
Book 1 + Takeoff and Landing Ground Rules

J. Hebert, Jr.
C. A. Whitney
E. C. Laudeman
G. T. Draper

Convair Aerospace Division of
General Dynamics Corporation

FOREWORD

The STOL Takeoff and Landing Ground Rules Report was prepared by the Convair Aerospace Division of General Dynamics Corporation under USAF Contract F33615-71-C-1754, Project 643A, "STOL Tactical Aircraft Investigation." This contract was sponsored by the Prototype Division of the Air Force Flight Dynamics Laboratory. The USAF Project Engineer was G. Oates (PT) and the Convair Aerospace Program Manager was J. Hebert. C. A. Whitney, G. T. Draper, and E. C. Laudeman were the principal contributors.

The research reported was conducted during the period from 7 June 1971 through 31 January 1973. This report was submitted by the author on 31 January 1973 under contractor report number GDCA-DHG73-001.

This report has been reviewed and is approved.

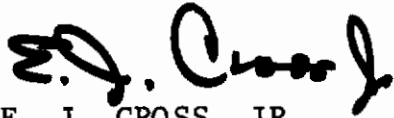

E. J. CROSS, JR.
Lt. Col. USAF
Chief, Prototype Division

ABSTRACT

The takeoff and landing performance of tactical STOL transports is entirely dependent on rough field operational capability, ground rules, and specified criteria. A brief study was conducted to assess the impact of stall margins, rolling friction, braking friction, rotation rate, and climb gradient. The STOL handling qualities criteria that provide allowances for the relationship of takeoff and landing distances were briefly investigated. The recommended guidelines to be used for tactical STOL transports operating on a 2000-foot CBR 6 field are:

A 1000-foot clearway at each end of runway.

Takeoff decision is made at the rotation point.

Three-engine takeoff from decision point.

Rejected takeoff from decision point.

Initial landing flare $\approx 7\text{-}1/2$ degrees to AIM point at 100 feet past the approach end of the runway.

Waveoff capability at 50 feet or continue to partial flare and touchdown.

Rolling coefficient = 0.10.

Braking coefficient = 0.30 to 0.50.

Wheel spinup activates lift dumpers and brakes.

Full braking in one second.

Thrust reversal activated in two seconds and is effective to zero knots.

Indicators or markings for visual cues.

The following takeoff and landing ground rules are recommended. .

Takeoff

1. Rotation speed greater than or equal to minimum speed ($V_R \geq V_{\min}$).
2. Liftoff speed greater than or equal to 1.2 times minimum speed ($V_{LO} \geq 1.2 V_{\min}$).
3. Rotation rate less than or equal to 8 degrees per second ($\dot{\theta} \leq 8 \text{ deg/sec}$).
4. Tangential acceleration greater than or equal to zero ($a_T \geq 0$).
5. Flaps are set in the takeoff position at the start of the takeoff run.

Landing

1. Power approach speed greater than or equal to 1.15 times minimum speed ($V_{PA} \geq 1.15 V_{\min}$) or minimum speed plus 10 knots ($V_{PA} \geq V_{\min} + 10 \text{ kt}$).
2. Touchdown speed is equal to power approach speed ($V_{TD} = V_{PA}$).
3. Touchdown, nose-up attitude greater than or equal to the static ground attitude.
4. Rotation rate less than or equal to eight degrees per second ($\dot{\theta} \leq 8 \text{ deg/sec}$).
5. Maximum rate of sink less than or equal to 1000 feet per minute ($R/S \leq 1,000 \text{ fpm}$)

Minimum flying speed is defined in the takeoff and landing ground rules as being the greater of:

1. Power-on stall speed with the most critical engine failed, all other engines at takeoff power, and out of ground effect.
2. A speed limited by reduced forward field of vision or extreme nose-up pitch attitude.
3. The speed at which abrupt and uncontrollable pitching, yawing, or rolling occurs in and out of ground effect condition (i.e., loss of control about any single axis).
4. The speed which is a safe margin above the speed where intolerable buffet or structural vibration is encountered.

The appropriate paragraphs of MIL-F-8785B (Reference 1) that should be considered as integral requirements when determining STOL performance are:

- 3.3.9.1, 3.3.9.2, 3.3.9.3, 3.5.2.1, 3.5.2.2, 3.5.2.3, 3.5.3, 3.5.3.1, and 3.5.3.2. Changes are recommended for Paragraphs 3.3.9.1 and 3.3.9.3.

TABLE OF CONTENTS

<u>Section</u>		<u>Page</u>
1	INTRODUCTION	1-1
2	CURRENT GROUND RULES AND CRITERIA	2-1
3	BASELINE CHARACTERISTICS	3-1
3.1	FOUR ENGINE TAKEOFF	3-3
3.2	REJECTED TAKEOFF	3-3
3.3	THREE ENGINE TAKEOFF	3-3
3.4	LANDING	3-5
3.5	CRITICAL CBR 6 RUNWAY LENGTHS	3-5
4	AIRCRAFT GROUND OPERATIONAL CAPABILITY	4-1
4.1	TYPICAL ANALYSIS DATA	4-3
4.2	ROLLING DRAG	4-4
4.3	BRAKING DRAG	4-4
5	AERODYNAMIC PERFORMANCE	5-1
5.1	MINIMUM FLYING SPEED (V_{\min})	5-2
5.2	TAKEOFF	5-2
5.2.1	Rotation Speed Greater Than or Equal to Minimum Speed ($V_R \geq V_{\min}$), Liftoff Speed Greater than or Equal to 1.1 Times Minimum Speed ($V_{LO} \geq 1.1 V_{\min}$)	5-3
5.2.2	Rotation Rate Less Than or Equal to 8 Degrees per Second ($\dot{\theta} \leq 8 \text{ deg/sec}$)	5-3
5.2.3	Coefficient of Rolling Friction	5-6
5.2.4	Gradient Capability	5-6
5.2.5	Tangential Acceleration Greater Than or Equal to Zero ($a_T \geq 0$)	5-6
5.3	LANDING	5-7
5.3.1	Power Approach Speed Greater Than or Equal to 1.15 Times Minimum Speed ($V_{PA} \geq V_{\min}$) or Minimum Speed Plus 10 Knots ($V_{PA} \geq V_{\min} + 10 \text{ KNOTS}$)	5-9

TABLE OF CONTENTS, Contd

<u>Section</u>		<u>Page</u>
5.3.2	Touchdown Speed is Equal to Power Approach Speed ($V_{TD} = V_{PA}$)	5-9
5.3.3	Touchdown, Nose Up Attitude Greater Than or Equal to the Static Ground Attitude	5-9
5.3.4	Rotation Rate Less than or Equal to 8 Degrees Per Second ($\dot{\theta} \leq 8 \text{ deg/sec}$)	5-9
5.3.5	Maximum Rate of Sink Less than or Equal to 1000 Feet Per Minute ($R/S \leq 1000 \text{ FPM}$)	5-9
5.3.6	Glide Slope Angle	5-10
5.3.7	Deceleration Capability	5-10
5.4	WAVEOFF	5-11
6	STABILITY AND FLIGHT CONTROL	6-1
6.2	REACTION TIME	6-3
6.3	GUSTS	6-3
6.4	FLIGHT CONTROL SYSTEM MECHANIZATION	6-4
6.5	PILOT TECHNIQUE	6-5
7	CONCLUSIONS AND RECOMMENDATIONS	7-1
8	REFERENCES	8-1

LIST OF ILLUSTRATIONS

<u>Figure</u>		<u>Page</u>
2-1	Takeoff Ground Rules	2-1
2-2	Landing Ground Rules	2-2
3-1	Externally Blown Flap Configuration	3-2
3-2	Engine Nacelle/Wing Relationship	3-3
3-3	Takeoff and Landing Profiles (Baseline EBF Configuration)	3-4
4-1	Braking Efficiency on a Commercial Four-Engine Jet Transport	4-2
4-2	Wheel Base, Center of Gravity Locations, and Tire Dimensions	4-3
4-3	Main and Nose Tire Spacings	4-3
4-4	Maximum Braking Coefficient Versus Percent Tire Slip	4-6
5-1	Ground Distance As a Function of Takeoff Margin and Gross Weight	5-4
5-2	Air Distance Over 50-Foot Obstacle As a Function of Takeoff Margin and Gross Weight	5-4
5-3	Total Distance Over a 50-Foot Obstacle As a Function of Takeoff Margin and Gross Weight	5-5
5-4	Total Takeoff Distance Over a 50-Foot Obstacle As a Function of Rotation Rate and Gross Weight	5-6
5-5	Total Distance Over a 50-Foot Obstacle As a Function of Rolling Friction and Gross Weight	5-7
5-6	Climb Gradient Available for the STOL Takeoff Program	5-8
5-7	Takeoff Air Distance As a Function of Gross Weight With and Without Deceleration	5-8

LIST OF ILLUSTRATIONS (Contd)

<u>Figure</u>		<u>Page</u>
5-8	Glide Slope Angle as a Function of Gross Weight	5-10
5-9	Climb Descent Capability as a Function of Velocity	5-11
5-10	Total Landing Ground Distance As a Function of Braking Coefficient	5-12
5-11	Waveoff Time History for the Externally Blown Flap Configuration With All Engines Operating	5-13
7-1	CBR 6 Field Guidelines	7-2

LIST OF TABLES

<u>Table</u>		<u>Page</u>
3-1	Baseline Configuration	3-1
3-2	Projected CBR 6 Runway Lengths	3-6

NOMENCLATURE

A	Time Delay For Braking Devices, Seconds
a_T	Acceleration Along The Flight Path, Ft./Sec. ²
b	Tire Width, Inches
C_L	Lift Coefficient
$C_{L_{MAX}}$	Maximum Lift Coefficient
CTOL	Conventional Takeoff and Landing
D_F	Rim Diameter, Inches
F	Distance Between Center Of Gravities Of Nose And Main Gear Systems, Inches
GW	Gross Weight, Pounds
J	Vertical Distance From Ground To C.G., Inches
L	Distance From Forward C.G. to Center Of Gravity Of Nose Gear System, Inches
M	Distance From Aft C.G. To Center Of Gravity Of Main Gear System, Inches
N_M	Number of Main Wheels

Contrails

N_N	Number of Nose Wheels
P	Vertical Load On Tire, Pounds
n_{AP}	Approach Load Factor
n_{LO}	Liftoff Load Factor
R/S	Rate of Sink, Ft./Min.
$R_{B/P}$	Braking Drag Ratios, Pounds
S	Percent Tire Slip
STOL	Short Takeoff and Landing
SWL_M	Single Main Gear Wheel Load, Pounds
SWL_N	Single Nose Gear Wheel Load, Pounds
V	True Airspeed, Knots
V_{AP}	Approach Airspeed, Knots
V_{LO}	Liftoff Speed, Knots
V_{MCA}	Minimum Control Speed, Airborne, Knots
V_{MCG}	Minimum Control Speed, On Ground, Knots
V_{Min}	Minimum Flying Speed, Knots
V_o	Speed At Start of Takeoff, Knots
V_{PA}	Power Approach Speed, Knots
V_R	Rotation Speed, Knots
V_S	Stall Speed, Knots

Contrails

V_{TD}	Touchdown Speed, Knots
V_{TO}	Velocity At Takeoff, Knots
V_2 or V_{OBS}	Speed Over The Obstacle, Knots
Z/D	Sinkage Ratio

GREEK SYMBOLS

γ	Flight Path Angle, Degrees
γ_{AP}	Approach Flight Path Angle, Degrees
δ	Percent Deflection
$\dot{\theta}$	Rotation Rate, Deg./Sec.
μ_B	Coefficient Of Braking Friction
μ_R	Coefficient Of Rolling Friction

Contrails

SECTION 1 INTRODUCTION

The objective of this study is to establish the ground rules and criteria to be used for defining, estimating, and demonstrating performance characteristics and other parameters associated with takeoff and landing of military STOL transports. At the present time, standards for determining the takeoff and landing performance of military STOL aircraft are inadequate.

The ground operational capability of STOL Transports is directly related to landing gear design and field conditions. The braking and rolling coefficients can be much larger than those for a conventional gear on a hard-surface runway. Typical rolling coefficient on a CBR 6 field is 0.10 and available braking as high as 0.60 with anti-skid braking and minimum time delays.

The takeoff and landing performance of STOL aircraft is extremely sensitive to the selected ground rules and criteria. A brief study was made to assess the impact of the following items on takeoff and landing performance: stall margins, rolling friction, braking friction, rotation rate, and climb gradients.

These ground rule variations were investigated using an externally blown flap configuration as a representative STOL aircraft. For the ground rules and criteria that are stability and control oriented the approach was to use MIL-F-8785B (Reference 1) as the framework from which flying qualities requirements were selected, although some of the basic requirements from MIL-F-8785B were qualitative or incomplete. In those cases, they were supplemented with material from other sources, such as MIL-F-83300 (Reference 2), or our own interpretations based on past design experience. The decision to rely on MIL-F-8785B was arrived at after reviewing some preliminary results of the stability derivatives sensitivity study being conducted under this contract, and from study of the Background Information and User Guides for both MIL-F-8785B and MIL-F-83300 (References 3 and 4). In addition, the STOL handling qualities criteria from Reference 5, which emphasized the landing-approach mode, were heavily relied upon for supplemental information.

Contrails

SECTION 2 CURRENT GROUND RULES AND CRITERIA

The takeoff and landing ground rules supplied by the Air Force for the Configuration Definition activities in Part 1 of this study are shown in Figures 2-1 and 2-2. Field elevation is 2,500 feet on a 93.4°F day (MIL-STD-210A Hot Day) and the critical field length is the actual field length, 2,000 feet.

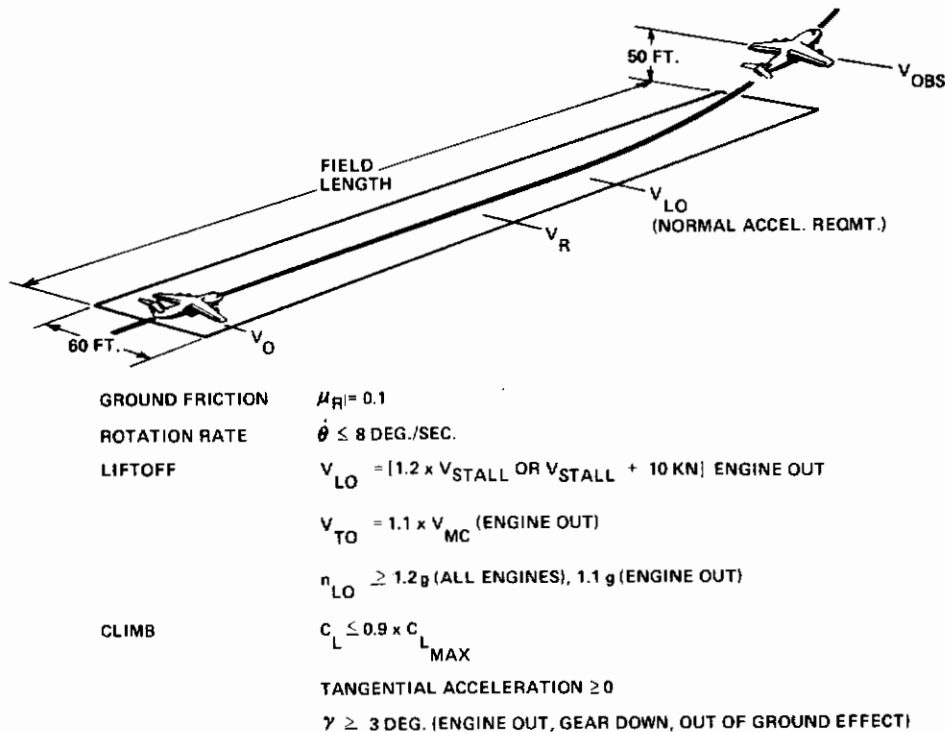
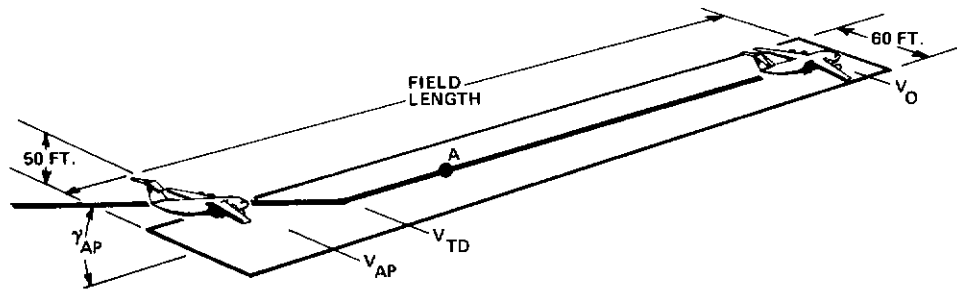

Figure 2-1. Takeoff Ground Rules



APPROACH	<p>WAVEOFF CAPABILITY AT OBSTACLE, CHANGES IN POWER SETTING, FLAP DEFLECTION, & THRUST VECTOR ANGLE ONLY</p> <p>$n_{AP} = 1.2g$ (ALL ENGINES), $1.1g$ (ENGINE OUT) AT V_{AP}</p> <p>γ_{AP} SUCH THAT PILOT CAN KEEP TOUCHDOWN POINT IN VIEW & AIRPLANE TOUCHES DOWN MAIN GEAR FIRST</p> <p>$V_{AP} \geq 1.1 \times V_{MC}$ (ENGINE OUT)</p> <p style="padding-left: 20px;">$\geq 1.1 \times V_S$ (ENGINE OUT)</p> <p style="padding-left: 20px;">$\geq 1.2 \times V_S$ (ALL ENGINES)</p> <p>$\dot{\theta} \leq 8 \text{ DEG./SEC.}$</p>
TOUCHDOWN	<p>LAND WITHOUT FLARE</p> <p>$V_{\text{SINK TD}} \leq 2/3 \times V$ SINK DESIGN FOR LG</p>
BRAKING DEVICES ON	<p>A, TIME DELAY OF $\begin{cases} 2 \text{ SECONDS FOR REVERSE THRUST} \\ 1 \text{ SECOND FOR BRAKES \& SPOILERS} \end{cases}$</p>
BRAKING FRICTION	$\mu_B = 0.25$

Figure 2-2. Landing Ground Rules

SECTION 3

BASELINE CHARACTERISTICS

The externally blown flap configuration was sized using the ground rules and criteria from Part 1 of this study, as discussed in Section 2. The configuration was designed to meet the 2,000-foot takeoff distance over a 50-foot obstacle requirement. The baseline configuration is summarized in Table 3-1.

Table 3-1. Baseline Configuration.

Engine		GE13/F2B
Rated Thrust		18,600 lb
Takeoff Gross Weight		148,200 lb
Wing Area		1,550 ft ²
Gross Weight	} Mid Mission	134,200 lb
Wing Loading		86.6 lb/ft ²
Thrust/Weight		0.55
Takeoff Distance		2,000 ft
Landing Distance		1,320 ft

The GE13/F2B engine was scaled to a rated thrust of 18,600 lbs.

The general arrangement is shown in Figure 3-1. The engines installed in single nacelles, utilized annular cascades to reverse thrust. Auxiliary engines were located in the fuselage to supply boundary layer control on the wing leading edge device, the elevator, and the rudder. The cross section of the engine nacelle/wing relationship shown in Figure 3-2 illustrates the features of the variable-geometry leading edge flap and the double-slotted trailing edge flap.

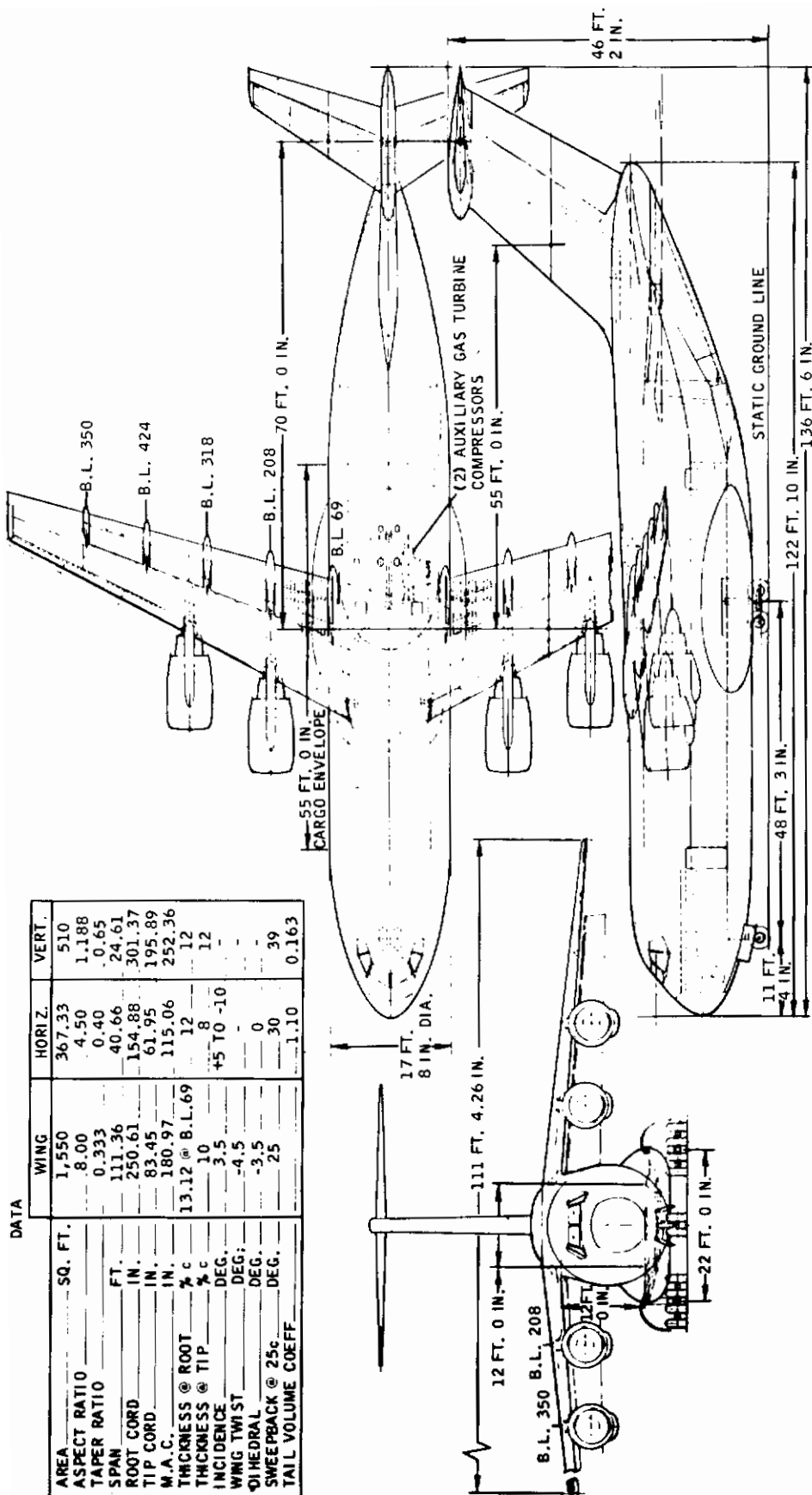

Figure 3-1. Externally Blown Flap Configuration

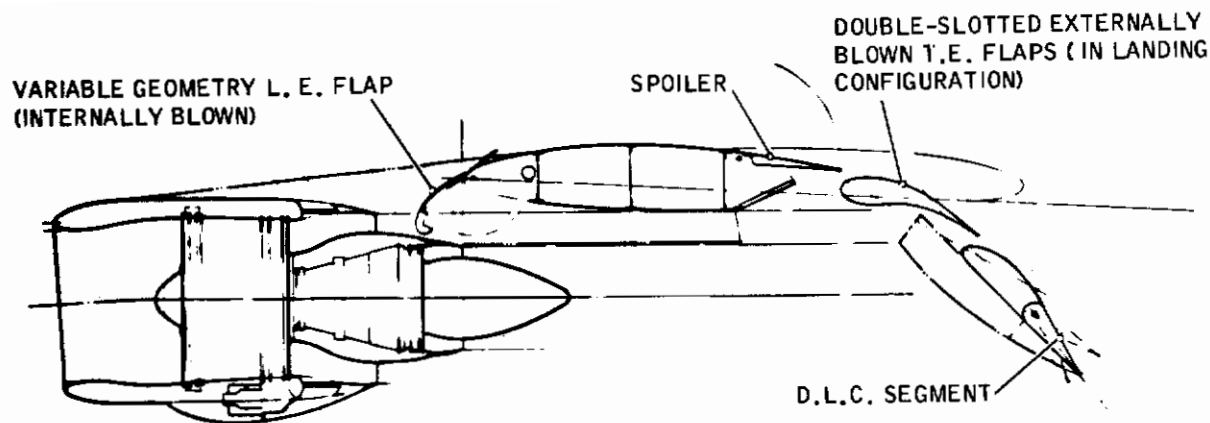

Figure 3-2. Engine Nacelle/Wing Relationship

3.1 FOUR ENGINE TAKEOFF

The STOL takeoff profile is shown in Figure 3-3a. A rotation speed of $1.08 V_{\min}$ is attained at the 1,300-foot distance. The aircraft rotates and lifts off at 1,500 feet and clears the 50-foot obstacle at 2,000 feet. This takeoff maneuver is based on a liftoff velocity equal to 1.2 times the stall velocity with one engine out.

3.2 REJECTED TAKEOFF

The 2,000-foot takeoff over the 50-foot obstacle implies an abort capability. This is true only if the takeoff maneuver is performed on a concrete runway (rolling coefficient equal to 0.025). On a CBR 6 field, the rolling coefficient is much closer to 0.10, as discussed in Section 4, and the aircraft would require over 920 feet to stop after reaching the decision point (Figure 3-3b). The rotation point (1,300 feet) was assumed to be the takeoff decision point. A one second time delay was used before applying braking ($\mu_B = 0.25$), and thrust reversal was applied one second later on two engines. Thrust reversal supplied by the cascade reversers decayed linearly to zero at zero knots. The aircraft rolled off the end of the runway and stopped at 2,220 feet.

An increase of seven percent in thrust/weight would allow the aircraft to reach a decision point early and furnish a rejected takeoff capability. This potential could also be provided by an improvement in braking coefficient and thrust reversal capability.

3.3 THREE ENGINE TAKEOFF

This assumes one engine out at the takeoff decision point (Figure 3-3c). The aircraft continues to accelerate to a three engine rotation speed (1,900 feet) and would

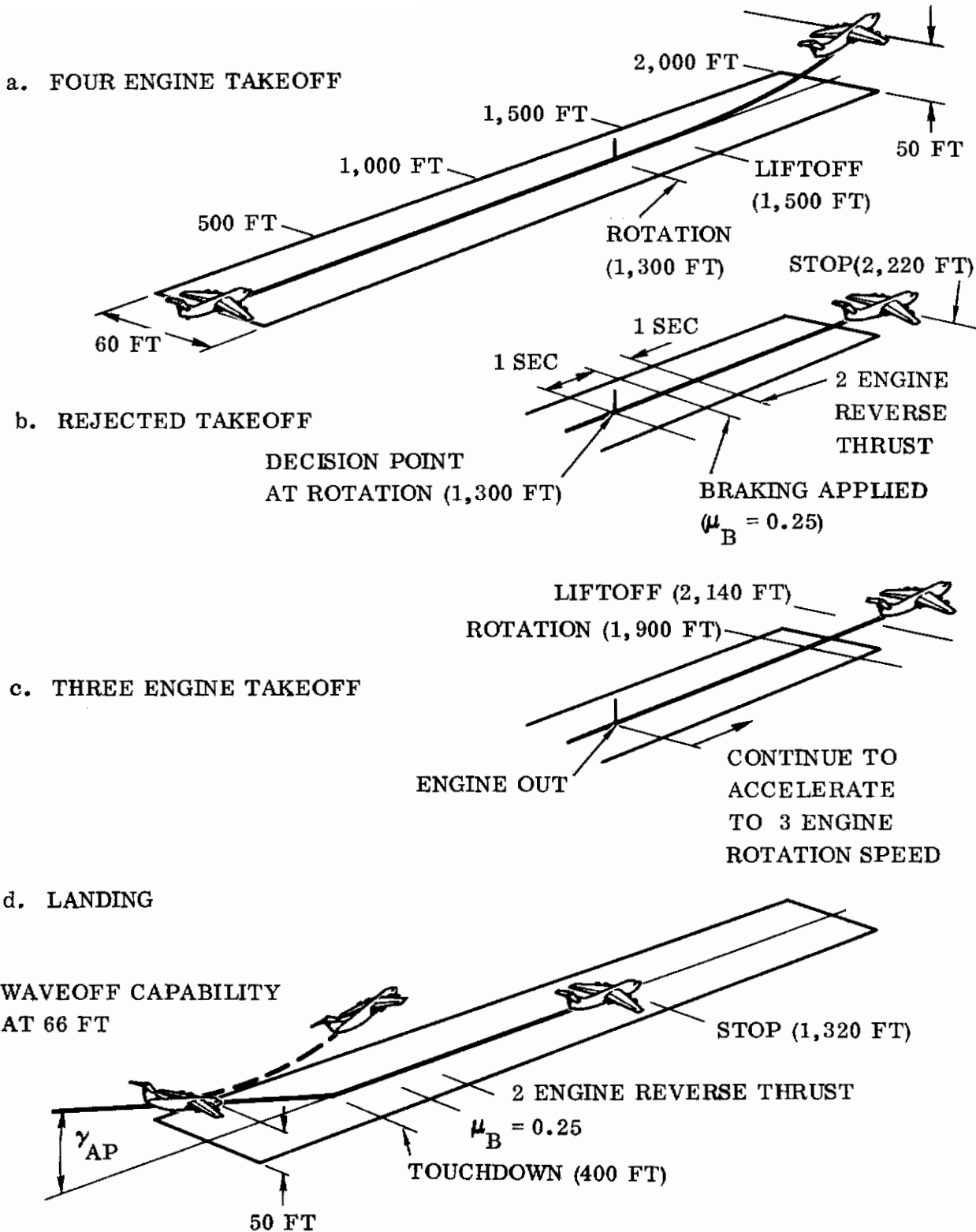

Figure 3-3. Takeoff and Landing Profiles (Baseline EBF Configuration)

lift off 140 feet past the end of the runway. Again, an increase in thrust would allow the aircraft to rotate earlier and lift off before or at the 2,000-foot distance.

3.4 LANDING

The landing profile is shown in Figure 3-3d. The approach flight path at the 50-foot obstacle is 7-1/2 degrees. A no-flare technique is used, and the aircraft touches down 400 feet from the edge of the runway. Using the 1- and 2-second time delays for braking and thrust reversal, the aircraft stops at a distance of 1,320 feet, which further emphasizes the apparent mismatch between takeoff and landing requirements. The aircraft had a waveoff capability above 66 feet.

3.5 CRITICAL CBR 6 RUNWAY LENGTHS

The baseline characteristics described in the preceding paragraphs indicate an apparent imbalance between the initial takeoff and landing requirements supplied by the Air Force for this study. Additional investigations were conducted to resolve these basic differences.

First, the takeoff decision point (rotation) was restricted to 1,200 feet. This was accomplished with a 3-1/2 percent increase in thrust and enabled the aircraft to clear the 50-foot obstacle at approximately 1,900 feet. The decision point now implies a balance in takeoff field length. A three engine takeoff was continued from the decision point and the aircraft lifted off before the 2,000-foot distance. With improved braking coefficients (the potential increase from 0.25 to 0.36 shown in Section 4), a rejected takeoff could be accomplished and the aircraft stopped within 1,900 feet. Improvements in thrust reversal, i. e., full two-engine thrust reversal down to zero knots, would reduce the required braking coefficient to 0.30 and below.

A more realistic landing approach for STOL aircraft would be a 7-1/2 degree glidescope to an aim point 100 feet past the approach end of the runway. At a 50-foot height approximately 400 feet from the aim point, the aircraft should have the capability to waveoff or continue to a partial flare of 3-1/2 degrees and touch-down 650 feet \pm 150 feet from the approach end of the runway. The aircraft would continue the rollout with a one-second time delay for braking ($\mu_B = 0.30$) and stop within 1,750 feet without thrust reversal. These projected CBR 6 runway lengths are summarized in Table 3-2.

Table 3-2. Projected CBR 6 Runway Lengths

	Decision Point (ft)	Lift Off (ft)	Touch Down (ft)	Stop (ft)
Takeoff				
a. Four Engine	1,200	1,400	---	---
b. Three Engine	1,200	2,000	---	---
c. Rejected	1,200	---	---	1,900
Landing	- 300	---	650 ± 150	1,750

The suggested CBR 6 takeoff and landing runway lengths reflect a vehicle that is more appropriately sized for a 2,000 foot runway with nominal safety margins. It is apparent that indicators or markings would be required to furnish appropriate visual cues for the takeoff decision point, aim point, and touchdown zone. A 1,000-foot clearway should be available at both ends of the runways, per the original TAC definition.

SECTION 4

AIRCRAFT GROUND OPERATIONAL CAPABILITY

Procedures used for the design of aircraft landing gear flotation components are adequate for conventional runways but are limited in the provision of related, meaningful design data for an operation on soils.

A review of available material indicates that for hard-surface runways a rolling coefficient of 0.025 and a braking coefficient of 0.30 is available. In other situations, the runway condition and gear flotation determine the rolling coefficient. The available braking coefficient for surfaces in general, is influenced by the following factors:

1. Delay in brake application after touchdown.
2. Vertical load on the wheels.
3. Runway or ground surface friction characteristics.
4. Tire pressures.
5. Efficiency of the brake control system.

As a consequence, the braking system used on STOL Transport Aircraft should have the following capability:

1. Minimum-delay braking at touchdown (1 Sec.).
2. Increase vertical load by automatic lift dumping.
3. Braking main and nose wheels.

4. Low tire pressures to increase tire contact area.
5. Use of fully modulated adaptive anti-skid control system.

The efficiency of an anti-skid control system on a commercial four-engine jet (Convair 880 and 990) is shown in Figure 4-1. Note that for the driest field conditions, maximum braking coefficients of 0.55 were demonstrated. The Dehavilland DHC-6 has demonstrated an average deceleration of 0.435 on dry concrete with anti-skid braking on the main gear and spoilers deployed.

A procedure for establishing the various landing gear combinations of tire sizes, spacings and configurations which will allow 200 non-braking passes of a selected STOL aircraft on a standardized CBR 6 or equivalent soil surface is presented in Reference 6. In the present report, techniques for determining the rolling and braking drag are included to provide a correlation base.

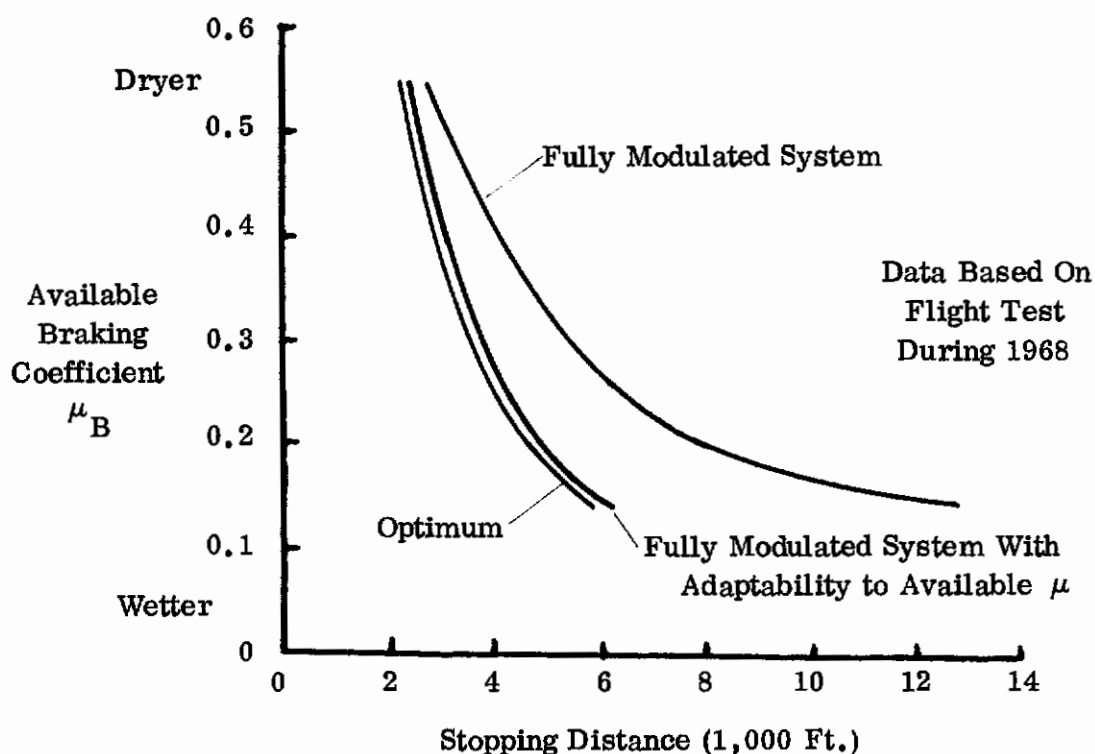

Figure 4-1. Braking Efficiency on a Commercial Four-Engine Jet Transport

4.1 TYPICAL ANALYSIS DATA

An analysis was conducted with the procedure described in Reference 6 on a STOL Transport Aircraft at an overload mid mission weight of 142,000 pounds. The wheel base, center of gravity locations, and tire dimensions are shown in Figure 4-2. The main and nose tire spacings are given in Figure 4-3.

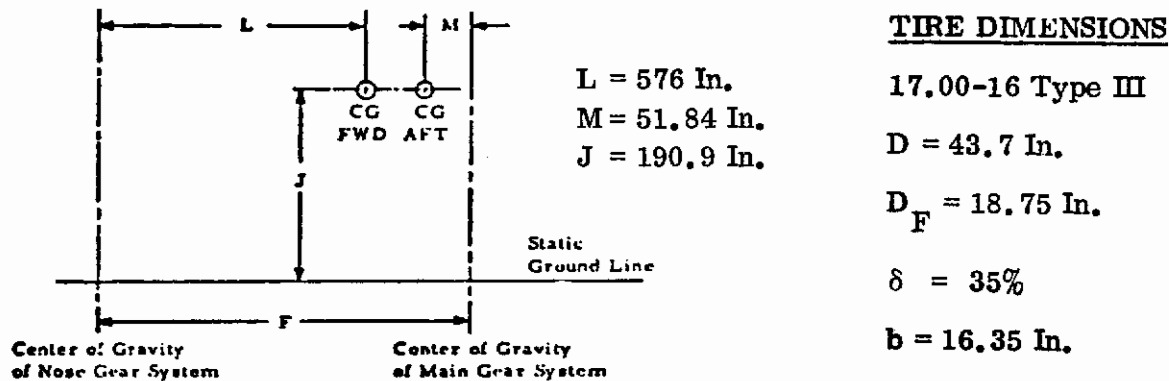

Figure 4-2. Wheel Base, Center of Gravity Locations, and Tire Dimensions

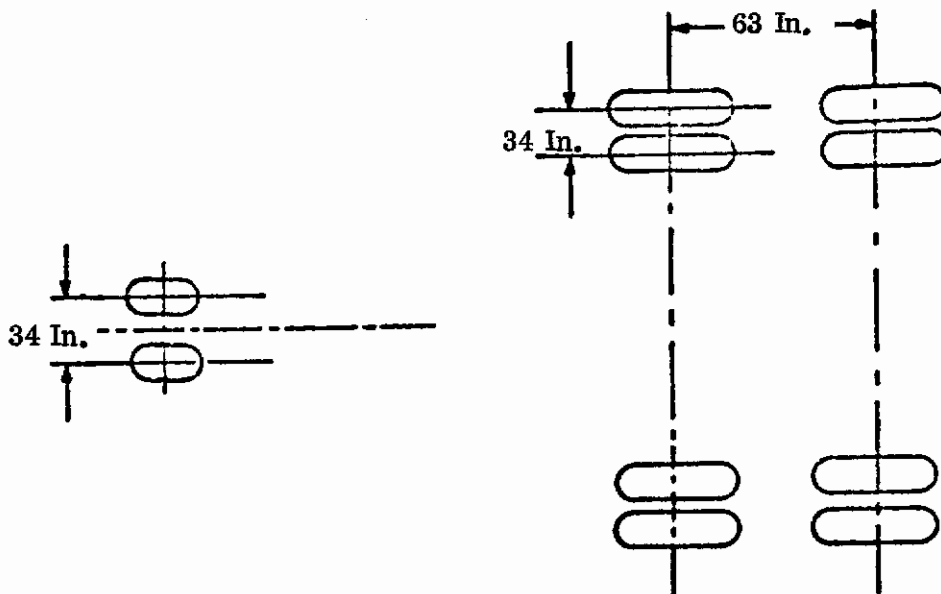

Figure 4-3. Main and Nose Tire Spacings

4.2 ROLLING DRAG

Calculate the following parameters using a per cent deflection (35) under which the tires will operate on a CBR 6 field.

a. Main Gear

$$\text{Single Wheel Load} = \text{SWL}_M = \frac{\text{GW} \cdot (\text{F} - \text{M})}{\text{F} \cdot \text{N}_M}$$

b. Nose Gear

$$\text{Single Wheel Load} = \text{SWL}_N = \frac{\text{GW} \cdot (\text{F} - \text{L})}{\text{F} \cdot \text{N}_N}$$

The total aircraft drag was calculated.

$$\text{Total Drag} = \text{SWL}_N + \text{SWL}_M$$

$$\text{Total Drag} = 1405 + 11,630 = 13,035 \text{ Lb.}$$

This value divided by the aircraft weight is the average rolling drag coefficient.

$$\mu_R = \frac{13,035}{142,000} = .092$$

4.3 BRAKING DRAG

Aircraft tire braking drag ratios (R_B/P) can be estimated for aircraft operating on nonslickened (due to rain) soil runways by use of the following equations:

$$\frac{R_B}{P} = 10.0 \left(\frac{Z}{D} \right) + \frac{45.0 D^2}{P} \left(\frac{Z}{D} \right)^{1/2} \left(\frac{S}{100} \right)^{1/2}$$

for $0.01 \leq \frac{Z}{D} \leq 0.06$, where

$\left(\frac{Z}{D} \right)$ is the sinkage ratio previously calculated for a given rolling tire

$\frac{Z}{D} = 0.0184$ (Main Tire) and 0.0112 (Nose Tire) for the example configuration

P = vertical load on the tire

S = percent tire slip

Note that braking sinkages will range from 2 to 4 times rolling sinkages and that the maximum R_B/P in the above equation will occur at a slip value of between 90 to 100%. This differs from rigid surface performance in that an aircraft on pavement obtains maximum braking resistance at between 4 to 20% for max braking. This value is much less than the 30% slip value given in TM 71-09. The aircraft with systems that actually limit slip to less than 90 to 100% in soil, will experience a braking resistance that can be calculated from the above equation by using the appropriate value for 'S'.

The parameter (R_B/P) can be calculated for the nose and main gear and the braking drag determined by the following expressions:

$$\text{Main Gear Braking Drag} = \left(\frac{R_B}{P}\right)_M \cdot N_M \cdot SWL_M$$

and

$$\text{Nose Gear Braking Drag} = \left(\frac{R_B}{P}\right)_N \cdot N_N \cdot SWL_N$$

The braking drags for the nose and main gear were then calculated for various values of slippage. These values were then divided by the aircraft weight and are summarized in Figure 4-4.

It can generally be concluded that for STOL operation on a CBR 6 field the following assumptions will apply until further in-depth studies are conducted:

1. Rolling Coefficient = 0.10 and Braking Coefficient = 0.30 to 0.50
2. Wheel spinup activates lift dumpers and brakes.
3. Full braking in 1 second and thrust reversal in 2 seconds.

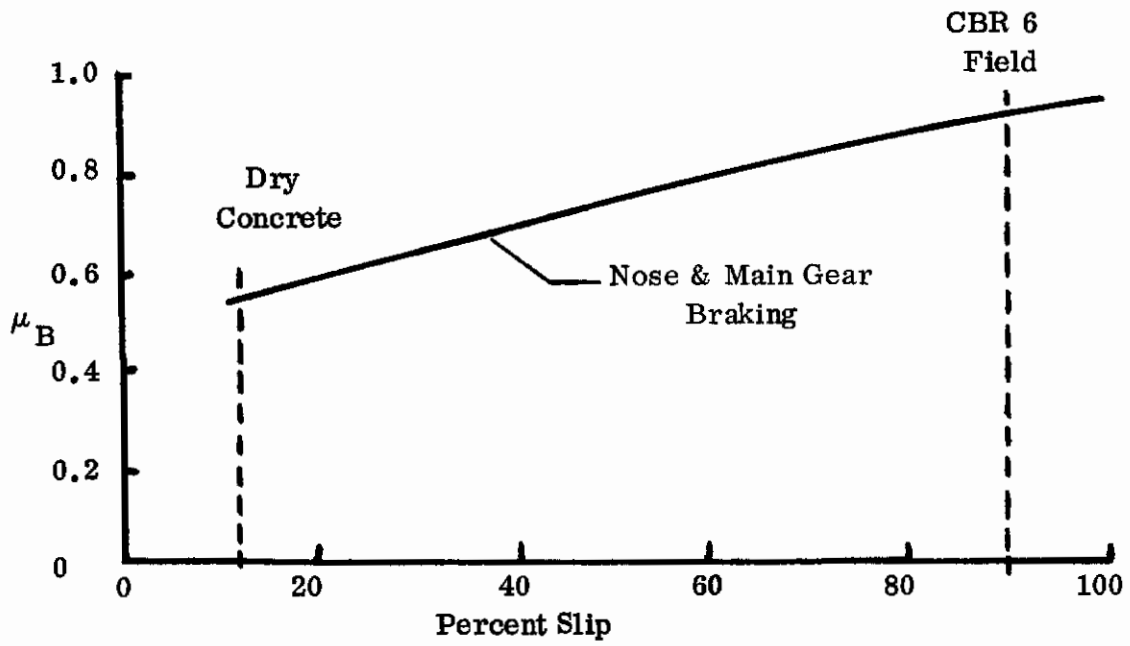

Figure 4-4. Maximum Braking Coefficient Versus Percent Tire Slip

SECTION 5

AERODYNAMIC PERFORMANCE

The takeoff and landing performance of STOL aircraft is extremely sensitive to specified ground rules. A brief study was made to assess the impact of various ground rule items on takeoff and landing performance. The items considered were:

1. Stall margins.
2. Coefficient of rolling friction for takeoff.
3. Coefficient of braking friction for landing.
4. Rotation rate during takeoff.
5. Climb gradient available during approach.
6. Climb gradient available after liftoff.

These ground rule variations were investigated using a digital computer program being developed during the STOL Tactical Aircraft Investigation. The baseline externally blown flap configuration was used as a representative STOL aircraft and is shown in Figure 3-1 and described in Reference 7. The Externally Blown Flap configuration was chosen rather than either the Mechanical Flap plus Vectored Thrust or the Internally Blown Flap because of greater thrust turning losses for a given rated thrust. Thus for a constant thrust to weight ratio the EBF has a lower acceleration capability and consequently is more sensitive to takeoff and landing ground rules.

Discussed below are the major factors which impact the performance of powered lift STOL tactical aircraft during takeoffs and landings. The data presented are the calculated distances with no field length factors or balanced field considerations incorporated.

5.1 MINIMUM FLYING SPEED (V_{\min})

A power on stall speed is only one of the constraints used in determining the minimum practical and safe airspeed. Other constraints are maximum allowable angle of attack, buffet, maximum control power and maximum control forces.

V_{\min} is defined as being the greater of:

1. Power on stall speed with; the most critical engine failed, all other engines at takeoff power, and out of ground effect.
2. A speed limited by reduced forward field of vision or extreme nose-up pitch attitude.
3. The speed at which abrupt and uncontrollable pitching, yawing, or rolling occurs in an out of ground effect condition, i.e., loss of control about any single axis, with the most critical engine failed.
4. The speed which is a safe margin above the speed where intolerable buffet or structural vibration is encountered.

Using the criteria above allows the maximum safe and practical performance to be extracted from a given configuration.

5.2 TAKEOFF

The major items which contribute to short takeoff ground distances and air distances are:

Ground Distances

1. Margin above V_{\min} at which liftoff occurs.
2. Coefficient of rolling friction.

Air Distance

1. Margin above V_{\min} at which liftoff occurs.
2. Rotation rate from ground attitude to liftoff or climb attitude.
3. Climb gradient involved.

The takeoff ground rules selected are presented below and were used during this study.

1. Rotation speed greater than or equal to minimum speed ($V_R \geq V_{\min}$).
2. Liftoff speed greater than or equal to 1.1 times minimum speed ($V_{LO} \geq 1.1 V_{\min}$).
3. Rotation rate less than or equal to 8 degrees per second ($\dot{\theta} \leq 8 \text{ deg/sec}$).
4. Tangential acceleration greater than or equal to zero ($a_T \geq 0$).
5. Flaps are set in the takeoff position at the start of the takeoff run.

5.2.1 ROTATION SPEED GREATER THAN OR EQUAL TO MINIMUM SPEED ($V_R \geq V_{\min}$), LIFTOFF SPEED GREATER THAN OR EQUAL TO 1.2 TIMES MINIMUM SPEED ($V_{LO} \geq 1.2 V_{\min}$) — A factor of 20 percent above V_{\min} was selected initially because of gust margin requirements and as being a near optimum between minimum distance to accelerate from zero ground speed to liftoff speed and best rate of climb speed. Figure 5-1 shows the ground distance and Figure 5-2 the air distance over a 50-foot obstacle for the baseline EBF configuration as a function of takeoff margin and gross weight. As expected the ground distance increases with increasing gross weight and increasing takeoff margin. In Figure 5-1, at the lower gross weights, there is an apparent minimum. However, this apparent trend is caused by the constraint that rotation speed be greater than or equal to V_{\min} . At an 8 deg/sec rotation rate the aircraft would have to start rotation before V_{\min} is reached to liftoff at the specified margin above V_{\min} . To compensate for this, rotation is initiated at or greater than V_{\min} and the resulting liftoff is at a greater margin above V_{\min} than specified. Air distance, shown in Figure 5-2, decreases as takeoff margin increases but for margins greater than 25 percent the decrease in air distance becomes fairly constant.

The total distance over a 50-foot obstacle is shown in Figure 5-3. The minimum distance, at a constant gross weight, occurs with a margin of approximately 20 percent above V_{\min} . This 20 percent margin above V_{\min} also insures that sufficient maneuvering capability, 0.44 normal g's, is available to obviate the requirement for a minimum maneuver margin.

5.2.2 ROTATION RATE LESS THAN OR EQUAL TO 8 DEGREES PER SECOND ($\dot{\theta} \leq 8 \text{ DEG/SEC}$) — Total takeoff distance over a 50-foot obstacle as a function of rotation rate of constant gross weights is presented in Figure 5-4. Within the range considered, the insensitivity of takeoff distance to rotation rate allows other considerations to determine rotation rate. Estimates for the EBF baseline configuration show that a pitch acceleration of 16 deg/sec², as recommended by Reference 2, would give a pilot rating of 3 1/2, and when integrated over the rotation period is equivalent to a constant 8 deg/sec rotation rate.

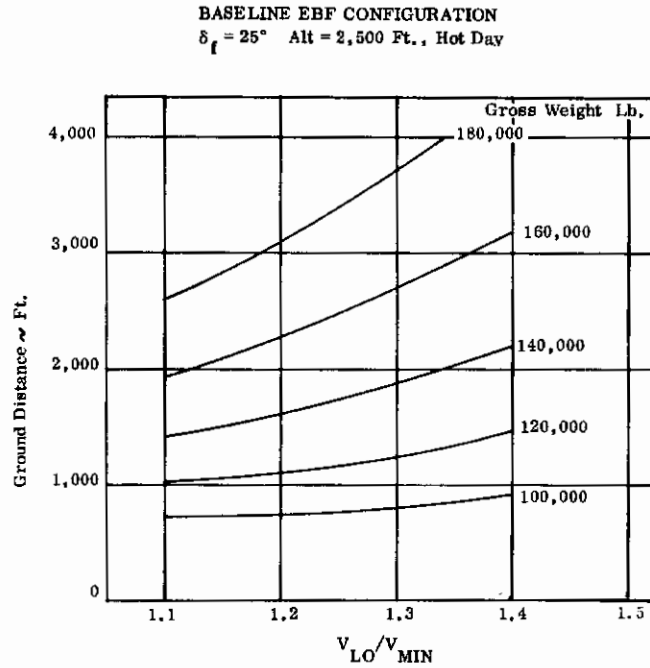

Figure 5-1. Ground Distance As a Function of Takeoff Margin and Gross Weight

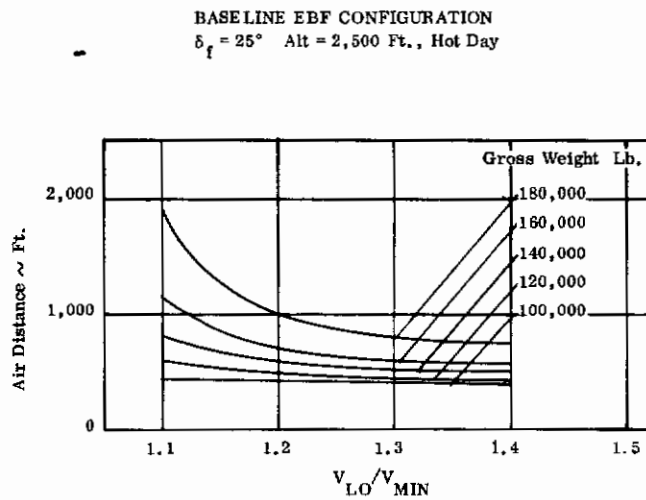

Figure 5-2. Air Distance Over 50-Foot Obstacle As a Function of Takeoff Margin and Gross Weight

BASELINE EBF CONFIGURATION
 $\delta_f = 25^\circ$ Alt = 2,500 Ft., Hot Day

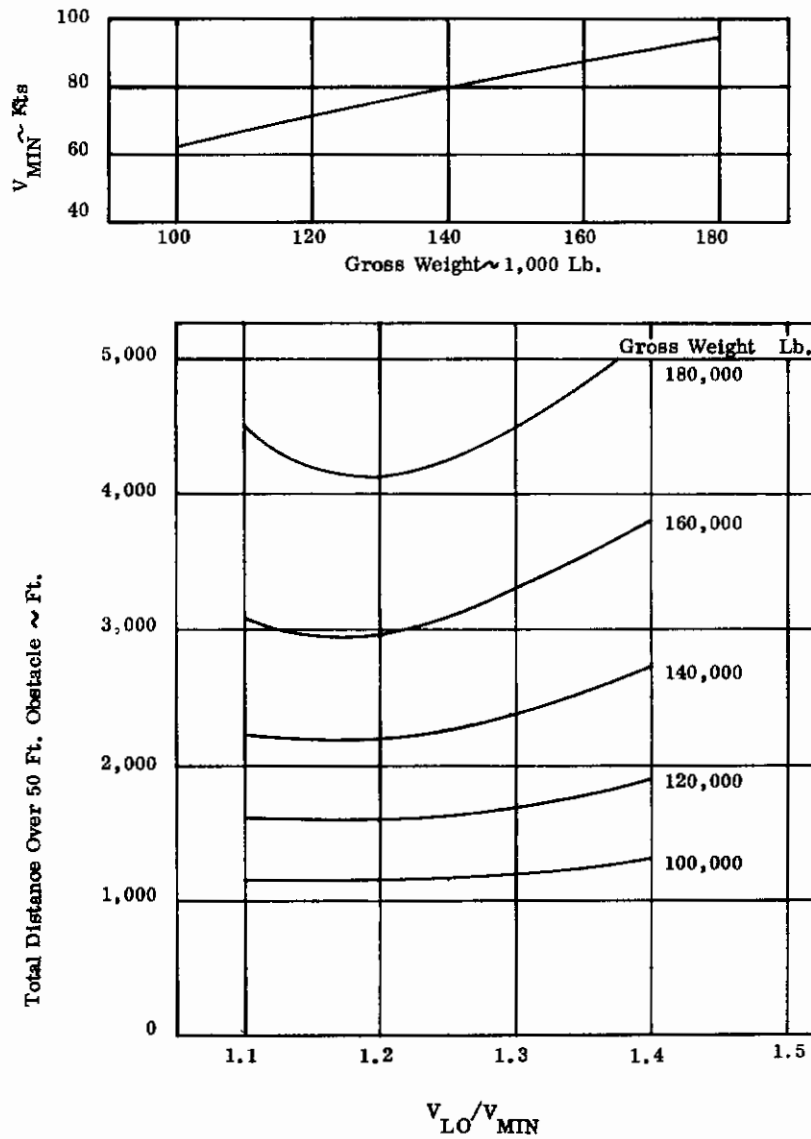

Figure 5-3. Total Distance Over a 50-Foot Obstacle As a Function of Takeoff Margin and Gross Weight

BASELINE EBF CONFIGURATION
 $\delta_f = 25^\circ$ Alt = 2,500 Ft., Hot Day
 $V_{LO}/V_{MIN} = 1.2$

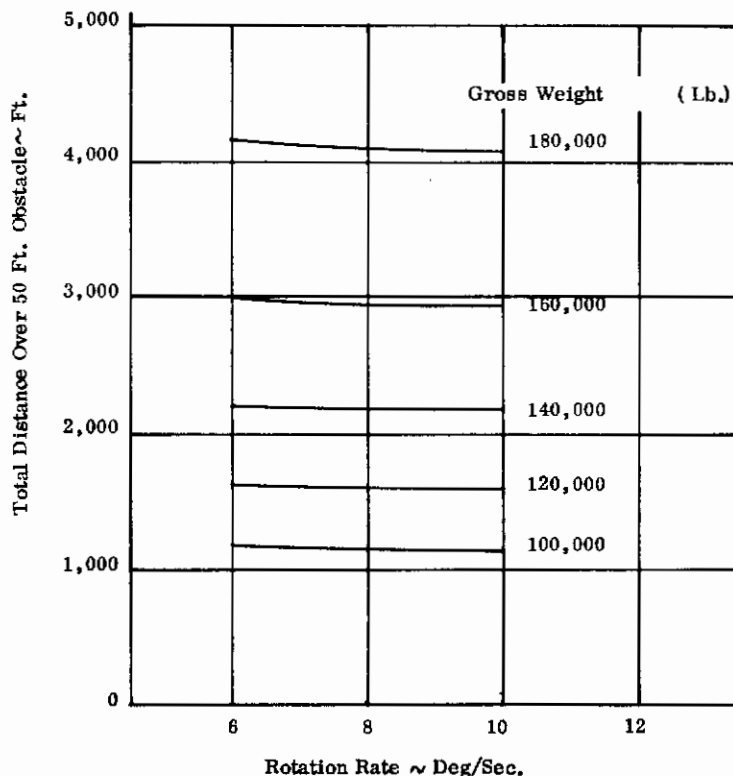

Figure 5-4. Total Takeoff Distance Over a 50-Foot Obstacle As a Function of Rotation Rate and Gross Weight

5.2.3 COEFFICIENT OF ROLLING FRICTION — As shown in Figure 5-5 the coefficient of rolling friction has a significant impact on the takeoff distance. Guidelines for this parameter are given in Section 3.0 (0.025 for dry concrete and 0.10 for a CBR 6 field).

5.2.4 GRADIENT CAPABILITY — Figure 5-6 shows a map of climb gradient available for the STOL takeoff spectrum. Adequate gradient is available for all speeds using the EBF baseline configuration. It is recommended that the climb gradient should meet or exceed the minimums of Reference 8, i.e., for 4 engine aircraft with one engine failed the climb gradient shall be greater than 3 percent or 300 FPM rate of climb, whichever is greater.

5.2.5 TANGENTIAL ACCELERATION GREATER THAN OR EQUAL TO ZERO ($a_T \geq 0$) — The tangential acceleration, i.e., the acceleration along the flight path, should be greater than or equal to zero at all times during the takeoff.

BASELINE EBF CONFIGURATION

$\delta_f = 25^\circ$ ALT = 2,500 FT, HOT DAY

$V_{LO}/V_{MIN} = 1.2$

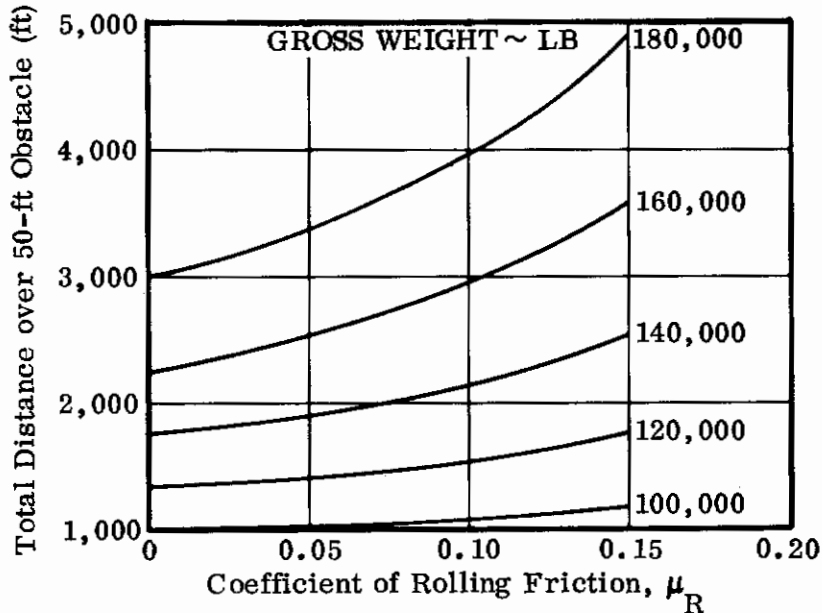

Figure 5-5. Total Distance Over a 50-Foot Obstacle as a Function of Rolling Friction and Gross Weight

This constraint is imposed to eliminate the potentially hazardous situation where the aircraft is allowed to decelerate during the airborne portion of the takeoff and exchange aircraft kinetic energy for altitude. Even though this decelerating technique yields a small decrease in the takeoff-air distance, as shown in Figure 5-7, it requires the pilot to pushover to a lower flight path angle, in close proximity to the ground, after the obstacle is cleared. If the tangential acceleration is equal to or greater than zero, however, the takeoff flight path may be continued to an altitude where a decrease in flight path angle can be accomplished with a higher degree of confidence.

5.3 LANDING

The three major aspects of landing performance are:

1. Approach and touchdown speed.
2. Glide slope angle.
3. Deceleration capability.

Possible inclusion in this list are waveoff requirements and minimum speed.

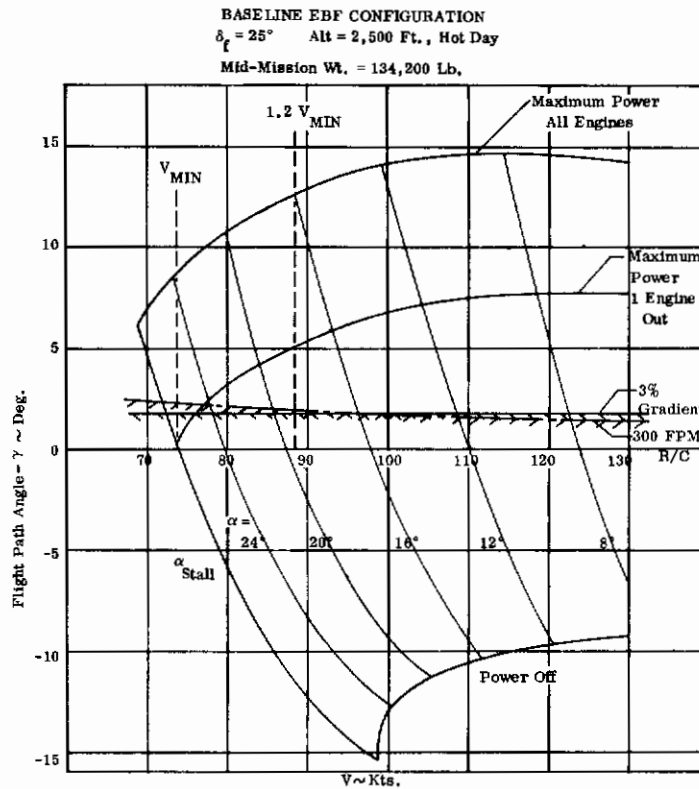

Figure 5-6. Climb Gradient Available for the STOL Takeoff Spectrum

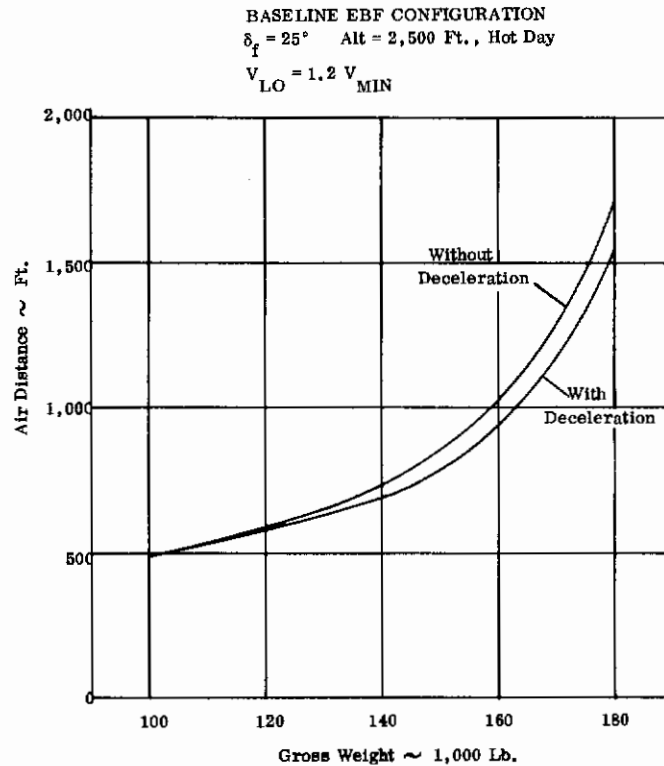

Figure 5-7. Takeoff Air Distance As a Function of Gross Weight With and Without Deceleration

These items, however are covered elsewhere in this document, Section 5.1 and 5.4. The landing ground rules presented below were used for this study:

1. Power approach speed greater than or equal to 1.15 times minimum speed ($V_{PA} \geq 1.15 V_{min}$) or minimum speed plus 10 knots ($V_{PA} \geq V_{min} + 10 \text{ Kts.}$)
2. The power setting used during approach is constant to touchdown.
3. Touchdown, nose up attitude greater than or equal to the static ground attitude.
4. Rotation rate less than or equal to 8 degrees per second ($\theta \leq 8 \text{ deg/sec}$).
5. Maximum rate of sink less than or equal to 1,000 feet per minute ($R/S \leq 1,000 \text{ FPM}$).

5.3.1 POWER APPROACH SPEED GREATER THAN OR EQUAL TO 1.15 TIMES MINIMUM SPEED ($V_{PA} \geq 1.15 V_{min}$) OR MINIMUM SPEED PLUS 10 KNOTS ($V_{PA} \geq V_{min} + 10 \text{ KNOTS}$) — The ratio of approach speed to minimum speed is discussed in Section 6.3 and is intended as a gust protection measure and maneuver margin. This minimum speed margin provides a maneuver margin of approximately 0.3 normal g's.

5.3.2 TOUCHDOWN SPEED IS EQUAL TO POWER APPROACH SPEED ($V_{TD} = V_{PA}$) — Touchdown speed is set equal to the power approach speed to simplify pilot work load and insure maximum precision in touchdown point. No rate of sink at touchdown is specified other than the maximum rate of sink during the approach. The rationale behind a constant air speed - constant sink rate approach is to maintain a constant attitude throughout the final part of the approach for flight path precision. Also, with this method a flare close to the ground and the accompanying inaccuracies in touchdown are avoided.

5.3.3 TOUCHDOWN, NOSE UP ATTITUDE GREATER THAN OR EQUAL TO THE STATIC GROUND ATTITUDE — The aircraft pitch attitude must be greater than or equal to the "three point" attitude. This constraint is imposed to eliminate nose-wheel first landings and the associated control problems.

5.3.4 ROTATION RATE LESS THAN OR EQUAL TO 8 DEGREES PER SECOND ($\theta \leq 8 \text{ DEG/SEC}$) — The rotation rate limit of 8 degrees per second is determined by a level of pitch acceleration and is discussed further in Section 5.2.2 above.

5.3.5 MAXIMUM RATE OF SINK LESS THAN OR EQUAL TO 1000 FEET PER MINUTE ($R/S \leq 1000 \text{ FPM}$) — The maximum rate of sink was set using guidelines suggested by Reference 5. The justification for this maximum is, "that

pilots are reluctant to exceed a rate of descent of 1000 Ft./Min. when below an altitude of about 200 feet. Even in VFR conditions the time available for making decisions becomes too short. . . . "

5.3.6 GLIDE SLOPE ANGLE — The usual requirement for STOL aircraft is a "steep descent angle". Specifying an angle, however, is felt to be outside the scope of this document because of the unique requirements for each aircraft design which specify a minimum glide slope for; terrain avoidance, ground fire exposure, etc. Other aircraft which operate in the STOL environment have no requirement for a steep descent and need only meet a ground distance constraint. The maximum permissible glide slope angle however is set by the combination of approach speed and the maximum rate of sink discussed in Section 5.3.5 above. Glide slope angle as a function of gross weight is shown in Figure 5-8, and a map of climb/descent gradient capability for one gross weight is shown in Figure 5-9, for the baseline Externally Blown Flap configuration.

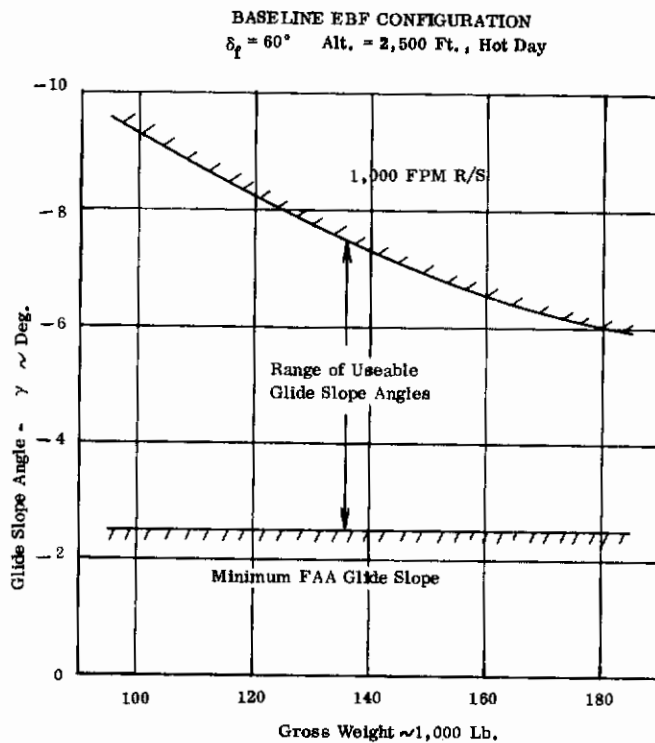

Figure 5-8. Glide Slope Angle as a Function of Gross Weight

5.3.7 DECELERATION CAPABILITY — Deceleration from touchdown to stop can be accomplished with three major aircraft systems, used either singly or in combination. These systems include wheel braking, aerodynamic braking and reverse thrust. Wheel brakes are the most common form of aircraft deceleration devices

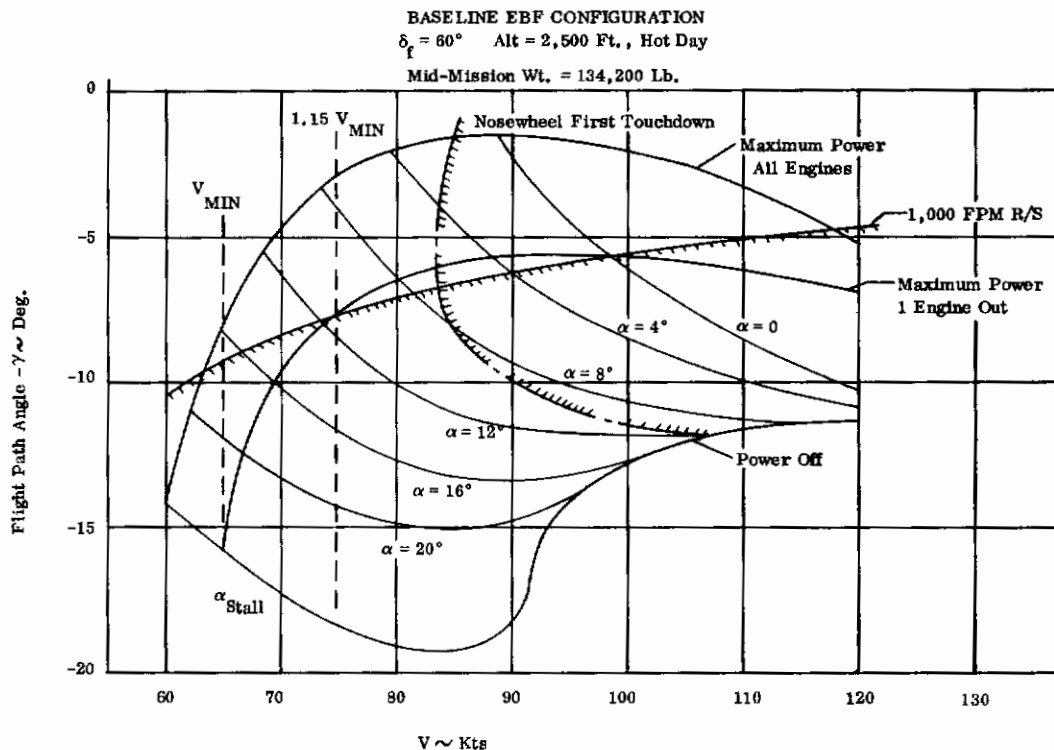

Figure 5-9. Climb Descent Capability as a Function of Velocity

and should be used to their maximum effectiveness. Sample values for braking friction are shown in Figure 5-10 and discussed in Section 4. For current technology braking systems a one second time delay from touchdown to "brakes-on" is recommended. This one second delay allows the nose to be lowered to the ground attitude, the wheels to "spin-up" to ground speed and for the braking system to be applied. Aerodynamic braking is considered only in the sense of symmetrical spoiler or lift dumper actuation which increases aerodynamic drag but more importantly decreases or eliminates the wing lift and increases the wheel brake effectiveness. Reverse thrust systems should be used only if, as stated in Reference 2, they are safe and reliable, and should only be used symmetrically to avoid assymetric braking and subsequent steering difficulties. A two second delay after touchdown is appropriate to allow the throttles to be retarded, select reverse thrust, and increase the throttles from the idle position. An increment is also incorporated into the two second delay to avoid overloading the pilots with diverse tasks during one short time delay. Reverse thrust used should be to the maximum available within design and engine manufacturer's limits.

5.4 WAVEOFF

The current set of ground rules used for the STOL transport evaluation conducted during this contract effort did not specify a requirement pertaining to waveoff capabilities. The proposed civil regulations, Reference 8, do require waveoff

BASELINE EBF CONFIGURATION
 $\delta_f = 60^\circ$ Alt = 2,500 Ft., Hot Day
 $V_{PA}/V_{MIN} = 1.15$

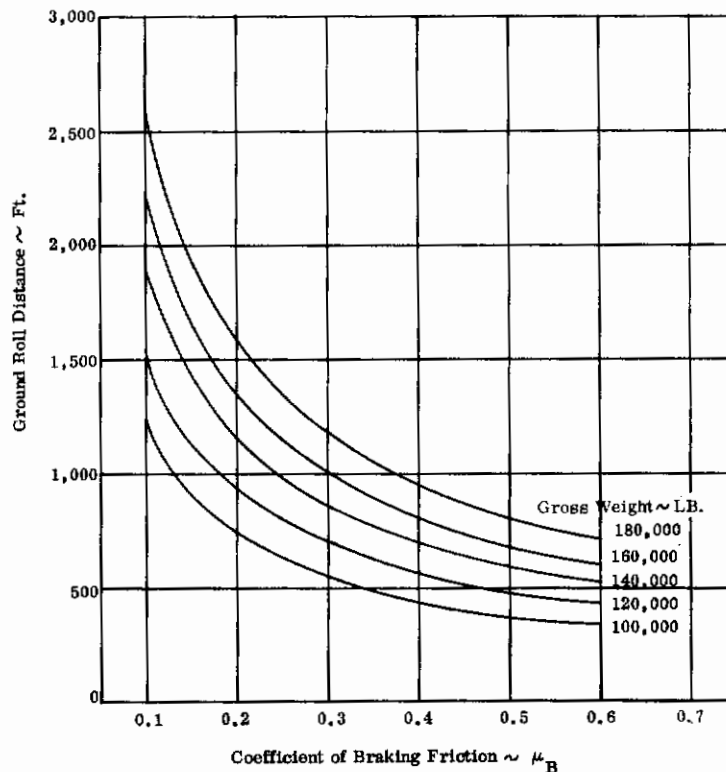

Figure 5-10. Total Landing Ground Distance As a Function of Braking Coefficient

capability for all engines operating and also with one engine inoperative. In Reference 5 it was also concluded that it is necessary that the pilot have the option of discontinuing the approach at any time before he initiates the landing flare. It is therefore recommended that the proposed takeoff and landing performance ground rules include requirements for waveoff capabilities. It is felt that the civil regulations are applicable for waveoff and it is recommended that the criteria given in paragraph XX.66 of Reference 8, as modified below, be included in the proposed requirements.

"The steady gradient of climb may not be less than 3.2 percent or the steady rate of climb may not be less than 250 feet per minute, whichever is greater, after the pullout during a balked landing maneuver with:

- (a) The engines at the power or thrust that is available eight seconds after initiation of movement of the power or thrust

lever from the minimum flight idle position to the takeoff position, or four seconds after initiation of movement of the power or thrust lever from the approved power position to the takeoff position, whichever is more critical.

- (b) A climb speed at the start of the waveoff of not more than the power approach speed (V_{PA}).
- (c) A change in configuration, e.g., retracting landing gear, partial retraction of flaps, etc., is allowed."

A sample case of the waveoff maneuver for the baseline Externally Blown Flap configuration is presented in Figure 5-11.

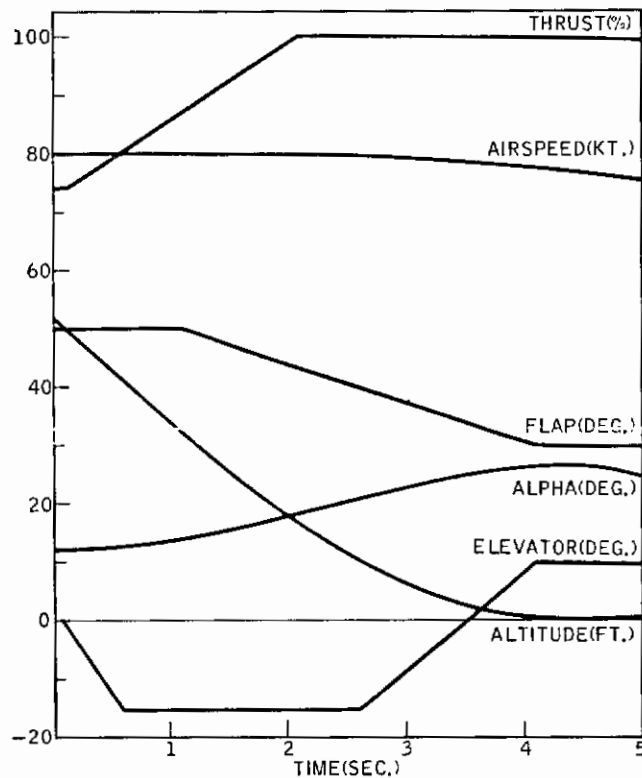

Figure 5-11. Waveoff Time History for the Externally Blown Flap Configuration With All Engines Operating

Contrails

SECTION 6

STABILITY AND FLIGHT CONTROL

For those aspects of the takeoff and landing performance specification that are stability and control oriented the approach was to use MIL-F-8785B (Reference 1) as the framework from which flying qualities requirements were selected, although some of the basic requirements from MIL-F-8785B were qualitative or incomplete. In those cases, they were supplemented with material from other sources, such as MIL-F-83300 (Reference 2), or Convair's interpretations based on past design experience. The decision to rely on MIL-F-8785B was arrived at after reviewing some preliminary results of the stability derivatives sensitivity study being conducted under this contract, and from study of the Background Information and User Guides for both MIL-F-8785B and MIL-F-83300 (References 3 and 4). In addition, the STOL handling qualities criteria from Reference 5, which emphasized the landing-approach, were heavily relied upon for supplemental information. Tentative commercial STOL Airworthiness Standards in Reference 8 were also reviewed and evaluated. Rationale for the selected criteria are given in the following paragraphs. From the STOL Tactical Aircraft Investigation Statement of Work, the handling qualities items to be considered in providing allowances for the relationship of takeoff and landing distances to power-on speed margins are the effects of engine failure, reaction time, gusts, flight control system mechanization, and pilot technique.

6.1 ENGINE FAILURE

The effects of engine failure do not appear directly as a power-on stall speed margin, but they will place restrictions on the minimum allowable rotation speed (V_R), speed over the obstacle (V_2), and approach speed (V_{PA}). Restrictions on V_R come about from consideration of thrust loss on the ground during takeoff roll, and the engine-out minimum control speed for this condition is designated V_{MCG} . References 1, 2 and 8 all contain criteria for establishing

V_{MCG} , given in paragraphs 3.3.9.1, 3.8.9.1 and XX.149 (b) of the respective specifications. There are no conflicts between the military and commercial requirements, but the commercial specification does not quantify a means for determining V_{MCG} . In general, this situation exists throughout those parts of Reference 8 which are concerned with flying qualities. The reason is that the military flying qualities specifications are structured for use as contractual documents, while the civil requirements are regulatory documents. Consequently, the military specifications are generally more useful for aircraft design purposes.

The V_{MCG} requirements given in References 1 and 2 are essentially the same. It is proposed that paragraph 3.3.9.1 of MIL-F-8785B be used, with one modification, as the criterion for establishing V_{MCG} . The proposed modification is that, since the STOL runway will generally be narrower than for CTOL, the maximum allowable deviation in ground track of 30 Ft. should be reduced for STOL operations. Typical runway widths are 150 Ft. for CTOL and 100 Ft. for STOL. The 60 Ft. runway width per TAC ROC 52-69 is unrealistic when consideration is given to turning radius, engine proximity to runway edge, etc. It is therefore recommended that the 30 Ft. deviation be reduced by the ratio 100/150, or to 20 Ft. The proposed requirements will be summarized at the end of this document.

The engine-out conditions that place restrictions on V_2 are related to thrust loss after the aircraft becomes airborne and the minimum control speed for this condition is designated V_{MCA} . Criteria for establishing V_{MCA} from Reference 1 are contained in Paragraphs 3.3.9.2 and 3.3.9.3. Additional airborne, engine-out criteria are specified in Paragraphs 3.3.9.4 and 3.3.9.5, but they are not normally critical design conditions. Reference 2 V_{MCA} criteria are given in paragraph 3.8.9.2, and in paragraph XX.149(a) for Reference 8. Here too, there are no conflicts between the three documents, and in this case, Reference 8 does supply quantitative V_{MCA} criteria. For consistency, it is proposed that the criteria from MIL-F-8785B, paragraphs 3.3.9.2 and 3.3.9.3, be used. One modification to paragraph 3.3.9.3, which deals with transient effects, is proposed. It is recommended that the qualitative criterion... "dangerous conditions can be avoided." be replaced by the requirement that the heading change shall not exceed 20 degrees and the peak bank angle not exceed 15 degrees.

A final item concerning engine-out control characteristics to be discussed is the waveoff. None of the flying qualities documents specifically discuss engine-out waveoff characteristics, and perhaps it can be rationalized that the engine-out waveoff is a double-failure condition, so that it need not be considered. However,

in some cases minimum engine-out climb capabilities in the Power Approach configuration are specified. It would be inconsistent to require engine-out climb capability without also requiring that V_{PA} never be less than V_{MCA} in the power approach configuration. It is therefore recommended that $V_{PA} \geq V_{MCA}$, with 0.3g normal load factor available at V_{PA} , where V_{MCA} is determined from the criteria in paragraph 3.3.9.2 of MIL-F-8785B, with the airplane in Power Approach configuration. The reason for proposing a factor of 1.0 for the speed margin between V_{MCA} and V_{PA} is that, in the operational situation, the remaining engines will be advanced from approach thrust to takeoff thrust at the pilot's discretion, so that transient effects should be minimal.

6.2 REACTION TIME

The effects of pilot reaction time will be reflected in those engine-out minimal control speeds for which transients are a factor. The affected requirements are those in paragraphs 3.3.9.1 and 3.3.9.3 of MIL-F-8785B. A time delay of at least 1 second is included in the criteria of paragraph 3.3.9.3. It is recommended that a time delay of 1 second also be included in the requirements of paragraph 3.3.9.1.

6.3 GUSTS

Gust effects will be considered as one of the factors which influence selection of the final stall or minimum speed margin. Gust models are given in Section 4.7 of MIL-F-8785B which can be used to evaluate gust sensitivity of individual configurations, but the specifications do not provide means to directly allow for gusts in the speed margin. More information on this subject is expected to be accumulated during the simulator studies that will be conducted under this contract, but for present purposes it is recommended that Reference 5 be used as the standard for establishing a minimum speed margin for the landing approach flight phase. An overall speed margin of 15% above minimum airspeed was considered to be adequate for the aircraft evaluated in Reference 5, and a good discussion of all the factors contributing to the final selection of a 15% margin is given on pages 12 through 14 of Reference 5. The comments relating to gusts are briefly summarized below:

"The 15-percent margin was sufficient to account for inadvertent speed excursions, wind shears, and gusts encountered during the tests, ... It was calculated that this margin permitted any of the following: (1) a vertical gust of 10 Kts. without buffeting, and larger magnitudes without exceeding maximum lift and control limits;..."

The above criteria should be considered tentative, since the aircraft evaluated did not include STOL turbofan-powered lift systems.

Surveys of the literature produced no information for the takeoff flight phase comparable to the work of Reference 5. However, our takeoff performance studies have indicated that optimum takeoff field lengths can be obtained by starting the rotation segment at a speed that will achieve liftoff at $1.2 V_{MIN}$. Intuitively, it would seem that a 20% margin should provide more than adequate gust allowance for takeoff. It is therefore recommended that $V_{LO} \geq 1.2 V_{MIN}$.

6.4 FLIGHT CONTROL SYSTEM MECHANIZATION

The identification of a simple, measurable parameter that could be used to relate flight control system characteristics to power-on speed margins is rather difficult. Required characteristics for the primary and secondary flight control systems are specified in Sections 3.5 and 3.6 of MIL-F-8785B, and there is little doubt that if all these required characteristics were demonstrated the aircraft would receive acceptable ratings. Detail design of the flight control system usually has not progressed to the point where compliance with these requirements can be shown during the early stages of the configuration design cycle, when takeoff and landing performance is generated. However, the importance of control system characteristics is illustrated by the following conclusion from Reference 5:

"It is concluded that with the generally low level of stability and damping present on STOL aircraft, the mechanical control characteristics assume a larger importance in overall handling than they do in conventional aircraft. The control friction, gradients, harmony, sensitivity, lags, etc., are as important as the basic stability and damping of the aircraft. In fact, in most cases, these are indistinguishable by the pilot and must be included in evaluating aircraft stability and control. Insufficient systematic work has been done to define acceptable mechanical control characteristics for STOL craft;..."

As to the recommended action for insuring satisfactory flight control system characteristics, it would appear that a good start has been made in MIL-F-8785B towards supplying design criteria, although many of the requirements are still qualitative. In traditional design practice for CTOL aircraft, in-depth analyses of potential flight control system concepts is not normally accomplished early in the predesign phase. Most of the early effort is devoted to properly sizing the external aerodynamic stabilizers and control surfaces, with mechanical design of the flight control system and detailed control force tailoring following at a later date. With properly sized external surfaces, mechanization and force tailoring could normally be accomplished on a low-risk basis. It is concluded that the first action required to assure that control system mechanical characteristics do not impose restrictions on STOL takeoff and landing performance would be

to simply reorient design philosophy to address, early in the design cycle, those flight control system criteria of MIL-F-8785B that have been identified in Reference 5 as being critical for STOL operations. The most appropriate requirements from MIL-F-8785B appear to be those in paragraphs 3.5.2.1, 3.5.2.2, 3.5.2.3, 3.5.3, 3.5.3.1 and 3.5.3.2.

6.5 PILOT TECHNIQUE

It is also difficult to establish a quantitative parameter to account for the effects of varying pilot technique on takeoff and landing performance. In the past, the most common means used to explicitly state these effects was to apply a factor to the demonstrated (or calculated) field lengths and/or absorb them into the stall or minimum speed margins. But there is also the implicit relationship to basic flying qualities of the airplane, in that the magnitude required for these factors will be directly related to the goodness or poorness of the basic flying qualities.

In this area there is a conflict between Civil and Military regulations, since the standard practice for commercial aircraft has been to require demonstration of maximum performance and then multiply those field lengths by factors (usually 1.15 for takeoff and 1/0.6 for landing) to account for the operational environment. On the other hand, military requirements in MIL-C-5011A do not specify factors on the demonstrated field lengths, the philosophy being that the demonstrated performance is to be conducted under conditions representative of an operational situation. Some additional information is contained in Reference 5, in which recommendations are made concerning the demonstration of landing performance. These comments are summarized below:

"The landing performance for STOL aircraft should be demonstrated under conditions close to an operational environment and factors pertinent to that craft should be used for determining the operational field length. The flight path should be constrained to a designated obstacle clearance angle as well as a designated landing area, and a task should be included to expose adverse handling characteristics. This is in contrast to the current procedure of FAR 25 and 121 of permitting a "maximum effort" landing demonstration anywhere on a dry runway and then dividing this distance by 0.6 to cover operational environments. A different method is recommended because one factor cannot cover the effects of gust, runway condition, and landing technique for all STOL aircraft."

Based on the above discussions, it is proposed that no additional factors be included in the takeoff and landing field lengths to account for pilot technique. It

Contrails

is felt that satisfactory results will be obtained by relying on the speed margins proposed in the previous paragraphs and by showing compliance with the handling qualities criteria from MIL-F-8785B and MIL-F-83300.

SECTION 7

CONCLUSIONS AND RECOMMENDATIONS

The following conclusions and recommendations are the results of the study. The recommended guidelines to be used for tactical STOL transport with high flotation gears operating on a CBR 6 field are:

1. 1,000 feet of clearway at each end of runway.
2. Takeoff decision is made at the rotation point.
3. Three engine takeoff from decision point.
4. Rejected takeoff from decision point.
5. Initial landing flare $\approx 7\text{-}1/2$ degrees to AIM point at 100 feet past the approach end of the runway.
6. Waveoff capability at 50 feet or continue to partial flare and touchdown.
7. Rolling coefficient = 0.10.
8. Braking coefficient = 0.30 to 0.50.
9. Wheel spinup activates lift dumpers and brakes.
10. Full braking in 1 second.
11. Thrust reversal activated in 2 seconds and is effective to zero knots.
12. Indicators or markings for visual cues.

These CBR 6 guidelines are shown in Figure 7-1.

The following takeoff and landing ground rules are recommended:

Takeoff

1. Rotation speed greater than or equal to minimum speed ($V_R \geq V_{\min}$).
2. Liftoff speed greater than or equal to 1.2 times minimum speed ($V_{LO} \geq 1.2 V_{\min}$).

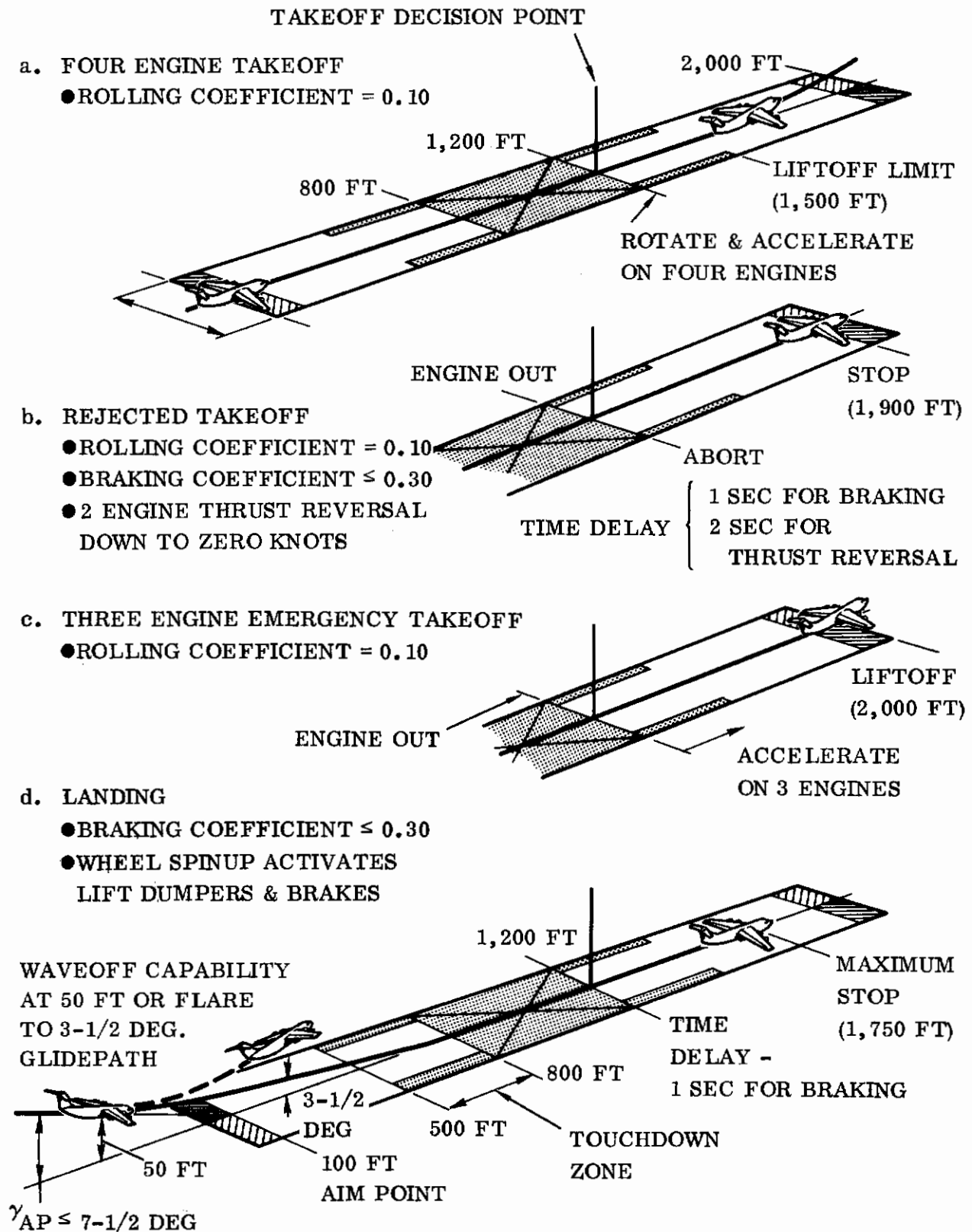

Figure 7-1. CBR 6 Field Guidelines

3. Rotation rate less than or equal to 8 degrees per second ($\dot{\theta} \leq 8$ Deg./Sec.).
4. Tangential acceleration greater than or equal to zero ($a_T \geq 0$).
5. Flaps are set in the takeoff position at the start of the takeoff run.

Landing

1. Power approach speed greater than or equal to 1.15 times minimum speed ($V_{PA} \geq 1.15 V_{min}$) or minimum speed plus 10 knots ($V_{PA} \geq V_{min} + 10$ Kts.).
2. Touchdown speed is equal to power approach speed ($V_{TD} = V_{PA}$).
3. Touchdown, nose up attitude greater than or equal to the static ground attitude.
4. Rotation rate less than or equal to 8 degrees per second ($\dot{\theta} \leq 8$ Deg./Sec.).
5. Maximum rate of sink less than or equal to 1,000 feet per minute ($R/S \leq 1,000$ FPM).

Minimum flying speed is defined in the takeoff and landing ground rules as being the greater of:

1. Power on stall speed with; the most critical engine failed, all other engines at takeoff power, and out of ground effect.
2. A speed limited by reduced forward field of vision or extreme nose-up pitch attitude.
3. The speed at which abrupt and uncontrollable pitching, yawing, or rolling occurs in and out of ground effect condition, i.e., loss of control about any single axis.
4. The speed which is a safe margin above the speed where intolerable buffet or structural vibration is encountered.

The appropriate paragraphs of MIL-F-8785B (Reference 1) that should be considered as integral requirements when determining STOL performance are: 3.3.9.1, 3.3.9.2, 3.3.9.3, 3.5.2.1, 3.5.2.2, 3.5.2.3, 3.5.3, 3.5.3.1, and 3.5.3.2. Changes are recommended for Paragraphs 3.3.9.1 and 3.3.9.3. The modified paragraphs are:

3.3.9.1 Thrust loss during takeoff run. It shall be possible for the pilot to maintain control of an airplane on the takeoff surface following sudden loss of thrust from the most critical factor. Thereafter, it shall be possible to achieve and maintain a straight path on the takeoff surface without a deviation of more than 20 feet from the path originally intended, with rudder pedal forces not exceeding 180 pounds. For the continued takeoff, the requirement shall be met when thrust is lost at speeds from the refusal speed (based on the shortest runway from which the airplane is designed to operate) to the maximum takeoff speed, with takeoff thrust maintained on the operative engine(s), using only elevator, aileron, and rudder controls. For the aborted takeoff, the requirement shall be met at all speeds below the maximum takeoff speed; however, additional controls such as nosewheel steering and differential braking may be used. Automatic devices which normally operate in the event of a thrust failure may be used in either case. A time delay of at least 1 second shall be considered.

3.3.9.3 Transient effects — The airplane motions following sudden asymmetric loss of thrust when airborne shall not exceed 20 degrees heading change or 15 degrees of bank angle. A realistic time delay of at least 1 second shall be considered before initiation of pilot corrective action.

SECTION 8

REFERENCES

1. Anon., "Military Specification - Flying Qualities of Piloted Airplanes", MIL-F-8785B (ASG), Aug. 1969.
2. Anon., "Military Specifications - Flying Qualities of Piloted V/STOL Aircraft", MIL-F-83300, Dec. 1970.
3. Chalk, C. R., et al, "Background Information and User Guide for MIL-F-8785B, Military Specification - Flying Qualities of Piloted Airplanes", Aug. 1969.
4. Chalk, C. R., et al, "Background Information and User Guide for MIL-F-83300, Military Specification - Flying Qualities of Piloted V/STOL Aircraft", March 1971.
5. Imis, R. C., Holzhauser, C. A., and Quigley, H. C., "Airworthiness Considerations for STOL Aircraft", NASA TND-5594, Jan. 1970.
6. Kraft, D. C. and Hoppenjans, J. R., "Design Procedure For Establishing Aircraft Capability To Operate on Soil Surfaces", AFFDL-TM-71-09-FEM, Sept. 1971.
7. Anon., "Configuration Definition Report", STOL Tactical Aircraft Investigation CDRL Item, Dec. 1971.
8. Anon., "Tentative Airworthiness Standards for Powered Lift Transport Category Aircraft", FAA, Aug. 1970.

Contrails

Unclassified

Security Classification

DOCUMENT CONTROL DATA - R & D		
(Security classification of title, body of abstract and indexing annotation must be entered when the overall report is classified)		
1. ORIGINATING ACTIVITY (Corporate author) Convair Aerospace Division General Dynamics Corporation San Diego, California 92138	2a. REPORT SECURITY CLASSIFICATION <p style="text-align: center; font-size: large;">Unclassified</p> 2b. GROUP	
3. REPORT TITLE STOL Tactical Aircraft Investigation Volume III - Performance Ground Rules and Methods Book I - Takeoff and Landing Ground Rules		
4. DESCRIPTIVE NOTES (Type of report and inclusive dates) Final Report (7 June 1971 to 31 January 1973)		
5. AUTHOR(S) (First name, middle initial, last name) J. Hebert, Jr., C. A. Whitney, E. C. Laudeman, G. T. Draper		
6. REPORT DATE May 1973	7a. TOTAL NO. OF PAGES 53	7b. NO. OF REFS 8
8a. CONTRACT OR GRANT NO. F33615-71-C-1754 b. PROJECT NO. 643A - Task 0001 c. d.	9a. ORIGINATOR'S REPORT NUMBER(S) GDCA-DHG73-001 9b. OTHER REPORT NO(S) (Any other numbers that may be assigned this report) AFFDL TR-73-21-Vol. III, Book 1	
10. DISTRIBUTION STATEMENT Approved for Public Release Distribution Unlimited		
11. SUPPLEMENTARY NOTES -----	12. SPONSORING MILITARY ACTIVITY Air Force Flight Dynamics Laboratory (PTA) Wright Patterson AFB, Ohio 45433	
13. ABSTRACT The takeoff and landing performance of tactical STOL transports is entirely dependent on rough field operational capability, ground rules, and specified criteria. A brief study was conducted to assess the impact of stall margins, rolling friction, braking friction, rotation rate, and climb gradient. The STOL handling qualities criteria that provide allowances for the relationship of takeoff and landing distances were briefly investigated. Recommended guidelines, takeoff and landing ground rules, and minimum flying speed are presented. The appropriate paragraphs of MIL-F-8785B that should be considered as integral requirements when determining STOL performance are: 3.3.9.1, 3.3.9.2, 3.3.9.3, 3.5.2.1, 3.5.2.2, 3.5.2.3, 3.5.3, 3.5.3.1, and 3.5.3.2. Changes are recommended for Paragraphs 3.3.9.1 and 3.3.9.3.		

DD FORM 1 NOV 65 1473

Unclassified

Security Classification

Contrails

Security Classification

14. KEY WORDS	LINK A		LINK B		LINK C	
	ROLE	WT	ROLE	WT	ROLE	WT
1. Externally Blown Flaps 2. Flight Controls 3. High Lift Systems 4. Performance Ground Rules 5. STOL Transport Aircraft 6. T.O. & Landing Standards						