

S.

DEPT. OF

COMMERCE
Contracts

ADA-084-897

AFFDL-TR-79-3119

LEVEL

②

44

ADA 084897

**SUPPRESSION OF AERODYNAMICALLY INDUCED CAVITY
PRESSURE OSCILLATIONS**

Leonard L. Shaw
Structural Integrity Branch
Structures and Dynamics Division

DTIC
ELECTE
MAY 29 1980

November 1979

TECHNICAL REPORT AFFDL-TR-79-3119

Final Report for Period February 1975 - May 1979

Approved for public release; distribution unlimited

DDC FILE COPY

80 5 29 054

AIR FORCE FLIGHT DYNAMICS LABORATORY
AIR FORCE WRIGHT AERONAUTICAL LABORATORIES
AIR FORCE SYSTEMS COMMAND
WRIGHT-PATTERSON AIR FORCE BASE, OHIO 45433

NOTICE

When Government drawings, specifications, or other data are used for any purpose other than in connection with a definitely related Government procurement operation, the United States Government thereby incurs no responsibility nor any obligation whatsoever; and the fact that the government may have formulated, furnished, or in any way supplied the said drawings, specifications, or other data, is not to be regarded by implication or otherwise as in any manner licensing the holder or any other person or corporation, or conveying any rights or permission to manufacture, use, or sell any patented invention that may in any way be related thereto.

This report has been reviewed by the Information Office (OI) and is releasable to the National Technical Information Service (NTIS). At NTIS, it will be available to the general public, including foreign nations.

This technical report has been reviewed and is approved for publication.

Leonard L. Shaw

LEONARD L. SHAW
Project Engineer

Davey Smith

DAVEY SMITH, Chief
Structural Integrity Br.
Structural Mechanics Div.

FOR THE COMMANDER

Ralph L. Kuster, Jr.

RALPH L. KUSTER, Jr., Colonel, USAF
Chief, Structural Mechanics Division

"If your address has changed, if you wish to be removed from our mailing list, or if the addressee is no longer employed by your organization please notify AFFDL/FGE, W-PAFB, OH 45433 to help us maintain a current mailing list".

Copies of this report should not be returned unless return is required by security considerations, contractual obligations, or notice on a specific document.

AIR FORCE/56780/6 May 1980 - 250

SECURITY CLASSIFICATION OF THIS PAGE (When Data Entered)

REPORT DOCUMENTATION PAGE		READ INSTRUCTIONS BEFORE COMPLETING FORM
1. REPORT NUMBER AFFDL-TR-79-3119	2. GOVT ACCESSION NO. AD-A084897	3. RECIPIENT'S CATALOG NUMBER
4. TITLE (and Subtitle) SUPPRESSION OF AERODYNAMICALLY INDUCED CAVITY PRESSURE OSCILLATIONS	5. TYPE OF REPORT & PERIOD COVERED Final Technical Report, Feb 1975 - May 1979	
7. AUTHOR(s) Leonard L. Shaw	8. CONTRACT OR GRANT NUMBER(s)	
9. PERFORMING ORGANIZATION NAME AND ADDRESS Air Force Flight Dynamics Laboratory (AFFDL/FBE) Air Force Wright Aeronautical Laboratories, AFSC Wright-Patterson Air Force Base, Ohio 45433	10. PROGRAM ELEMENT, PROJECT, TASK AREA & WORK UNIT NUMBERS 62201F 240D108 (17) 911	
11. CONTROLLING OFFICE NAME AND ADDRESS Air Force Flight Dynamics Laboratory (AFFDL/FBE) Air Force Wright Aeronautical Laboratories, AFSC Wright-Patterson Air Force Base, Ohio 45433	12. REPORT DATE November 1979	
14. MONITORING AGENCY NAME & ADDRESS (if different from Controlling Office) 11/12/79 (12) 62	13. NUMBER OF PAGES 62	
	15. SECURITY CLASS. (of this report) Unclassified	
16. DISTRIBUTION STATEMENT (of this Report) Approved for public release; distribution unlimited.		
17. DISTRIBUTION STATEMENT (of the abstract entered in Block 20, if different from Report)		
18. SUPPLEMENTARY NOTES		
19. KEY WORDS (Continue on reverse side if necessary and identify by block number) Cavity Flow, Cavity Oscillations, Pressure Oscillations, Suppression, Flight Tests		
20. ABSTRACT (Continue on reverse side if necessary and identify by block number) A flight test program was performed to gain further insight into the phenomenon of flow-induced cavity pressure oscillations and to evaluate the effectiveness of suppression concepts in eliminating or reducing the pressure oscillations. The cavities tested were rectangular with approximate dimensions of 17 inches long, 8.5 inches deep, and 8.75 inches wide and were instrumented with microphones, static pressure ports, and a thermocouple. The flight speeds ranged from Mach number 0.6 to 1.3 at pressure altitudes of 3,000, 20,000, and 30,000 feet. The suppression devices included leading edge spoilers and deflectors		

FORM 1 JAN 73 1473 EDITION OF 1 NOV 65 IS OBSOLETE

SECURITY CLASSIFICATION OF THIS PAGE (When Data Entered)

012 000

SECURITY CLASSIFICATION OF THIS PAGE (When Data Entered)

→ and trailing edge ramps and deflectors. Several combinations of these were tested. The results indicate that the flow-induced pressure oscillations in a cavity of the dimensions tested and for the speed range tested can be significantly reduced with leading edge spoilers in conjunction with a trailing edge ramp. Reductions as large as 30 dB were achieved for the predominant model frequency for a one-third octave band. Other combinations of the suppression devices afforded some reduction, but the spoiler ramp combination proved most effective. ←

SECURITY CLASSIFICATION OF THIS PAGE (When Data Entered)

AFFDL-TR-79-3119

FOREWORD

This work was performed by Mr. L. L. Shaw of the Structural Integrity Branch, Structures and Dynamics Division, Air Force Flight Dynamics Laboratory, Wright-Patterson Air Force Base, Ohio. This effort was conducted under Work Unit 24010108, "Flight Test of Cavity Oscillation Mechanisms and Suppression Devices."

This report presents and summarizes all of the work performed under this effort. The manuscript was released by the author in April 1979 as a Technical Report.

Accession	
NTIS Annual	
DDC TAB	
Unannounced	
Justification	
By	
Distribution	
Availability Code	
Dist	Available for special
A	

AFFDL-TR-79-3119

TABLE OF CONTENTS

SECTION		PAGE
I	INTRODUCTION AND BACKGROUND	1
II	DESCRIPTION OF TEST	2
	1. Test Articles	2
	2. Instrumentation	2
	3. Test Procedures	8
III	DISCUSSION OF RESULTS	11
	1. Cavity Temperature Variations	11
	2. Static Pressure Variations	13
	3. Fluctuating Pressure Level Variations	23
IV	CONCLUSIONS	51
	REFERENCES	52

Centrair

2-1-79

LIST OF ILLUSTRATIONS

AFFDL-TR-79-3119

FIGURE		PAGE
1	Standard SUU-41 Munitions Pod	3
2	Illustration of the Modifications Made on the Pod	4
3	Cavity Configurations Tested: (1) Basic Cavity, (2) Doors, (3) Doors and Trailing Edge Ramp, (4) Doors, Trailing Edge Ramp, and Leading Edge Spoilers, (5) Doors, Trailing Edge Ramp, and Airfoil, (6) Double Cavity, Center Divider Ramp, and Trailing Edge Ramp, (7) Double Cavity, Flow Deflectors on Leading Edge, Center Divider, and Trailing Edge, (8) Double Cavity, Flow Deflectors on Center Divider and Trailing Edge	5
4	Detailed Sketch of the Suppression Devices: A-Spoiler, B-Airfoil, C-Flow Deflectors	6
5	Instrumentation Location in the Single Cavity: M-Microphone, P-Static Pressure Tap, T-Thermocouple	7
6	Instrumentation Location in the Double Cavity: M-Microphone, P-Static Pressure Tap, T-Thermocouple	9
7	Modified SUU-41 Pod	10
8	Comparison of the Temperature for Each of the Configurations for the 30,000-Foot Altitude	12
9	Static Pressure for the Clean Single-Cavity Configuration	14
10	Static Pressure Longitudinal Variation for the Single-Cavity Configuration for 30,000-Foot Altitude	16
11	Comparison of Current Flight Data (-----) From the Single Cavity at 30,000 Feet at Mach Number 1.2 to the Wind Tunnel Data (——) in Reference 11	17
12	Comparison of Static Pressure Distribution for the Single Cavity with Doors (-----) and without Doors (——) for 30,000-Foot Altitude	18
13	Comparison of the Static Pressure Distribution for the Single Cavity with Doors Configuration with a Ramp (——) and without a Ramp (-----) for 30,000-Foot Altitude	19

AFFDL-TR-79-3119

LIST OF ILLUSTRATIONS (CONTINUED)

FIGURE		PAGE
14	Comparison of the Static Pressure Distribution for the Single Cavity with Doors Configuration with (——) and without (-----) a Ramp and Spoiler for 30,000-Foot Altitude	20
15	Comparison of the Static Pressure Distribution for the Single Cavity with Doors Configuration with (——) and without (-----) a Ramp and Airfoil for 30,000-Foot Altitude and Mach Number of 1.2	21
16	Comparison of the Static Pressure Distribution in the Single Cavity with Doors Configuration (-----) to the Double Cavity with Ramp on each Configuration (——) for 30,000-Foot Altitude	22
17	Comparison of the Static Pressure Distribution in the Single Cavity with Doors (-----) to the Double Cavity with Fore-Center-Aft Deflectors Configuration (——) for 30,000-Foot Altitude	24
18	Comparison of the Static Pressure Distribution in the Single Cavity with Doors (-----) to the Double Cavity with Center and Aft Deflectors (——) for 30,000-Foot Altitude	25
19	Perspective Representation of Successful Suppression Concepts	27
20	Effect of Upstream Spoilers at 45° Angle of Attack on Leading-Edge Bulkhead Pressure Signal: $M_\infty = 0.9$; $L/D = 2.3$ (continuous line refers to unmodified cavity)	28
21	Effect of Trailing-Edge Slant with and without Upstream Spoilers on Leading-Edge Bulkhead Pressure Signal: $M_\infty = 0.8$; $L/D = 2.3$ (continuous line refers to unmodified cavity; dashed line refers to trailing edge slant only; dotted line refers to combination of trailing-edge slant and upstream spoilers)	29
22	Effect of Trailing-Edge Slant in Combination with a Detached Cowl on Leading-Edge Bulkhead Pressure Signal: $M_\infty = 0.8$; $L/D = 2.3$ (continuous line refers to unmodified cavity; dashed line refers to cowl trailing edge located at cavity mouth level; dotted line refers to cowl trailing edge located 2 in. above cavity mouth level).	30
23	One-Third Octave Band Spectra for the Single Basic Cavity for Mach Number 0.8 and 3,000-Foot Altitude	31

LIST OF ILLUSTRATIONS (CONTINUED)

FIGURE		PAGE
24	Longitudinal variation of the Modal Frequency Amplitudes	32
25	One-Third Octave Band Spectra From the Single Basic Cavity From Microphone 7 for 30,000-Foot Altitude	33
26	One-Third Octave Band Spectra from the Single Basic Cavity From Microphone 7 for Mach Number 0.8 for 3,000- 20,000- and 30,000-Foot Altitudes	34
27	One-Third Octave Band Spectra from the Single Basic Cavity from Microphone 7 for Mach Number 1.20 for 20,000- and 30,000-Foot Altitudes	35
28	Comparison of the Spectra from the Single Cavity with (-----) and without (——) Doors for Mach Number 0.8 and 30,000-Foot Altitude	37
29	Comparison of the Spectra from the Single Cavity with (-----) and without (——) Doors for Mach Number 1.2 and 30,000-Foot Altitude	38
30	Comparison of the Spectra from the Single Cavity with Doors with (——) and without (-----) a Ramp for Mach Number 0.8 and 30,000-Foot Altitude	39
31	Comparison of the Spectra from the Single Cavity with Doors with (——) and without (-----) a Ramp for Mach Number 1.2 and 30,000-Foot Altitude	40
32	Comparison of the Spectra from the Single Cavity with Doors Configuration with (——) and without (-----) a Ramp and Spoiler for Mach Number 0.8 and 30,000-Foot Altitude	42
33	Comparison of the Spectra from the Single Cavity with Doors Configuration with (——) and without (-----) a Ramp and Spoiler for Mach Number 1.2 and 30,000-Foot Altitude	43
34	Comparison of the Spectra from the Single Cavity with Doors Configuration with (——) and without (-----) a Ramp and Airfoil for Mach Number 0.8 and 30,000-Foot Altitude	44
35	Comparison of the Spectra from the Single Cavity with Doors Configuration with (——) and without (-----) a Ramp and Airfoil for Mach Number 1.2 and 30,000-Foot Altitude	45

AFFDL-TR-79-3119

LIST OF ILLUSTRATIONS (CONCLUDED)

FIGURE		PAGE
36	Comparison of the Spectra from the Single Cavity with Doors and Ramp (——) and the Front Cavity with Doors and Ramp (-----) for Mach Number 0.8 and 30,000-Foot Altitude	47
37	Comparison of the Spectra from the Single Cavity with Doors (——) and the Rear Cavity with Doors and Ramp (-----) for Mach Number 0.8 and 30,000-Foot Altitude	49
38	Comparison of the Spectra from the Single Cavity with Doors and Ramp (——) and the Front Cavity with Doors and Ramp (-----) for Mach Number 1.2 and 30,000-Foot Altitude	49
39	Comparison of the Spectra from the Single Cavity with Doors and Ramp (——) and the Rear Cavity with Doors and Ramp (-----) for Mach Number 1.2 and 30,000-Foot Altitude	50

AFFDL-TR-79-3119

SECTION I

INTRODUCTION AND BACKGROUND

The aeroacoustic phenomenon associated with aerodynamically induced cavity pressure oscillations has been studied during the past 20 years by several investigators (References 1 through 15). Significant knowledge has been gained but the phenomenon, due to its complex nature, is not completely understood. Methods to predict the pressure oscillations occurring in open cavities, as determined from wind tunnel tests, have been reported by Smith and Shaw (Reference 15). Only a few of these previous investigations address the problem of suppressing the cavity pressure oscillations. Heller and Pliss (Reference 3) presents the results of a study in which numerous suppression concepts were evaluated through wind tunnel tests. They show that several devices can effectively suppress the oscillations; however, the effectiveness varied with (1) Mach number, (2) length-to-depth ratio, and (3) size and relative locations of the suppression devices.

The current effort was undertaken to verify the effectiveness of the most promising of these devices with flight tests. A munitions dispenser pod was modified to accommodate a single- or double-cavity configuration along with the oscillation suppression devices. The cavities were instrumented with microphones, static pressure taps, and a thermocouple. The modified pod was installed on the F-4 aircraft and flight tests were performed. Mach numbers for the flights ranged from 0.6 to 1.3 and the altitudes were 3,000, 20,000 and 30,000 feet. Data from eight different configurations were obtained. This report discusses and summarizes the results and conclusions of the flight tests.

Detailed description of the test articles, instrumentation, and test procedures are given in Section II. Section III presents a detailed discussion of the results. Included in the discussion are the effects of the suppression devices on the cavity temperature, static pressures and fluctuating pressure levels. Section IV summarizes the results of the program.

AFFDL-TR-79-3119

SECTION II

DESCRIPTION OF TEST

1. TEST ARTICLES

Figure 1 shows a picture of the SUU-41 munitions dispenser pod used in the tests. The standard pod has ten small compartments but was modified to accommodate two rectangular cavities. A drawing of the standard pod along with the modifications is shown in Figure 2. Each cavity was 8.5 inches deep, 17 inches long, and 8.75 inches wide. A cover was placed over the rear cavity to give a single-cavity configuration. The eight configurations tested are illustrated in Figure 3. Configuration 1 was a single rectangular cavity. Configuration 2 was the single cavity with side doors protruding into the free-stream flow. All remaining configurations had the doors installed in conjunction with the suppression devices. The third configuration was a single cavity with the trailing edge ramped at a 45° angle. The depth of the ramp was 3 inches. The fourth configuration was the same as the third with spoilers installed just ahead of the leading edge. The two spoilers were 1-5/8 inches high (which was the approximate boundary layer thickness at the 20,000 foot altitude), 2-3/4 inches long, and were installed at a 45° angle to the flow. Configuration 5 was the same as configuration 3 except an airfoil was installed just ahead of the ramp. The sixth configuration was a double-cavity configuration, with the center insert and the rear wall ramped. The seventh was a double-cavity configuration, with the flow deflectors on the leading edge, center insert, and the trailing edge. The deflectors were designed to deflect the flow away from the cavity openings. The final configuration was the same as the seventh except the deflector on the leading edge was removed. Figure 4 shows details of the suppression devices.

2. INSTRUMENTATION

The cavities were instrumented with Gulton MVA2100 microphones, static pressure taps, and an iron-constantan thermocouple. Figure 5 shows the location of the instrumentation for the single cavity. There were eight microphones, four static pressure taps, and one thermocouple

AFFDL-TR-79-3119

AIR FORCE

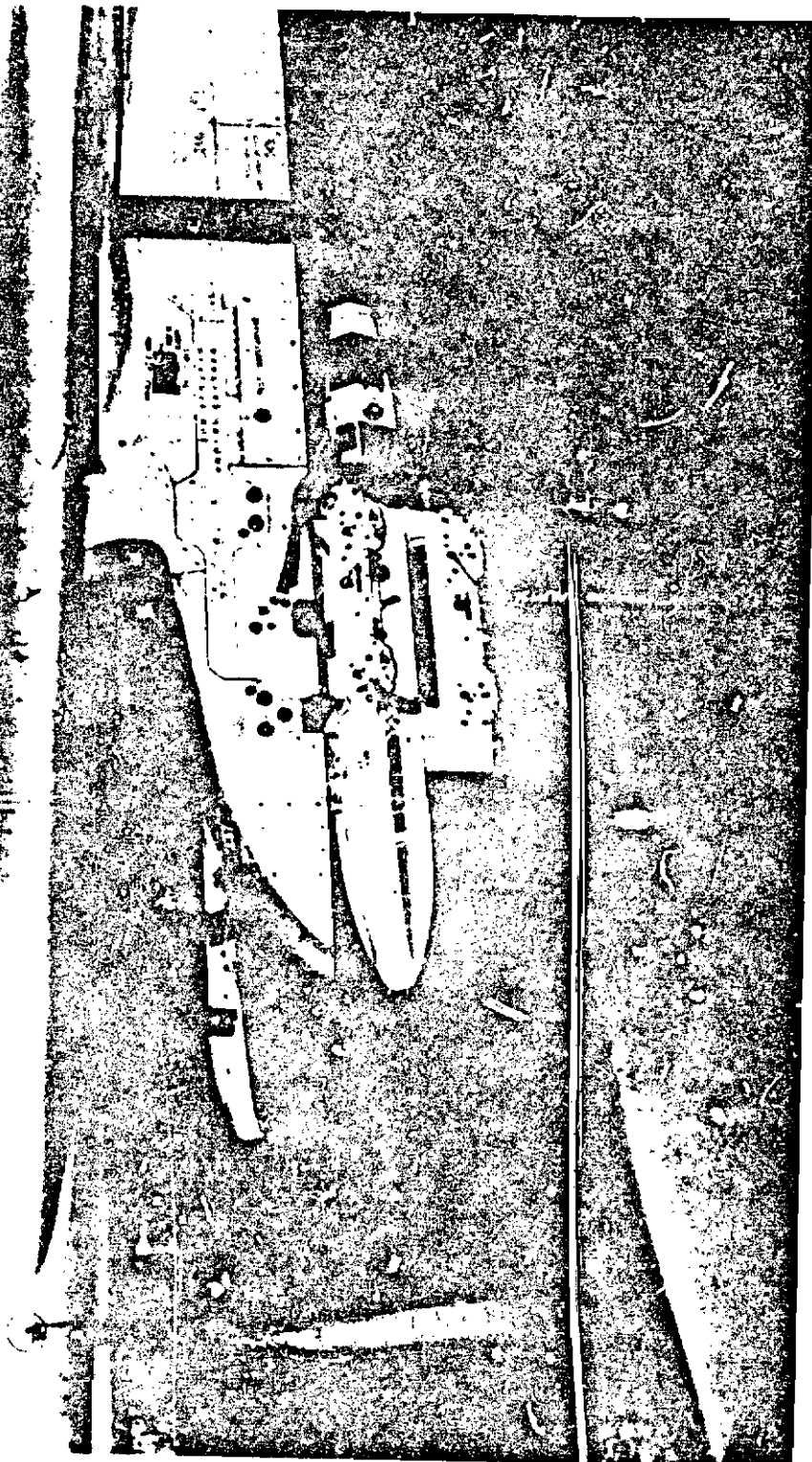

Figure 1. Standard SUU-4i Munitions Pod

AFFDL-TR-79-3119

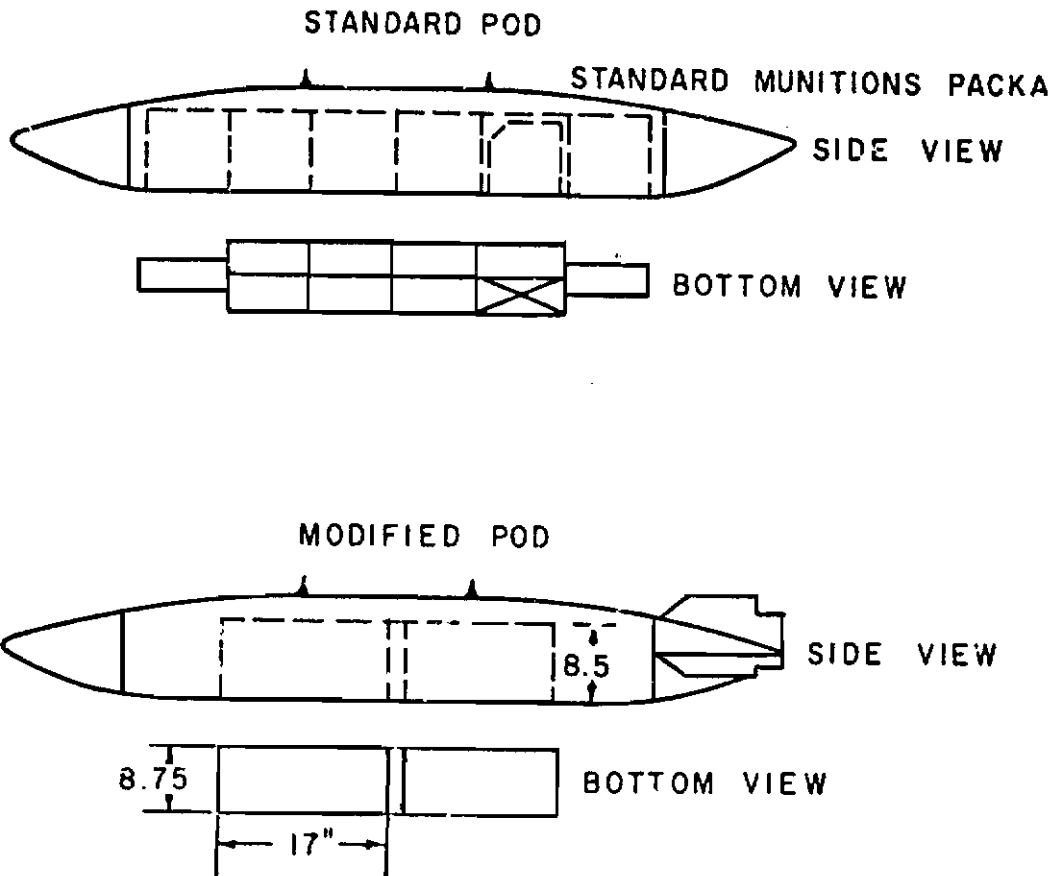

Figure 2. Illustration of the Modifications Made on the Pod

AFFDL-TR-79-3119

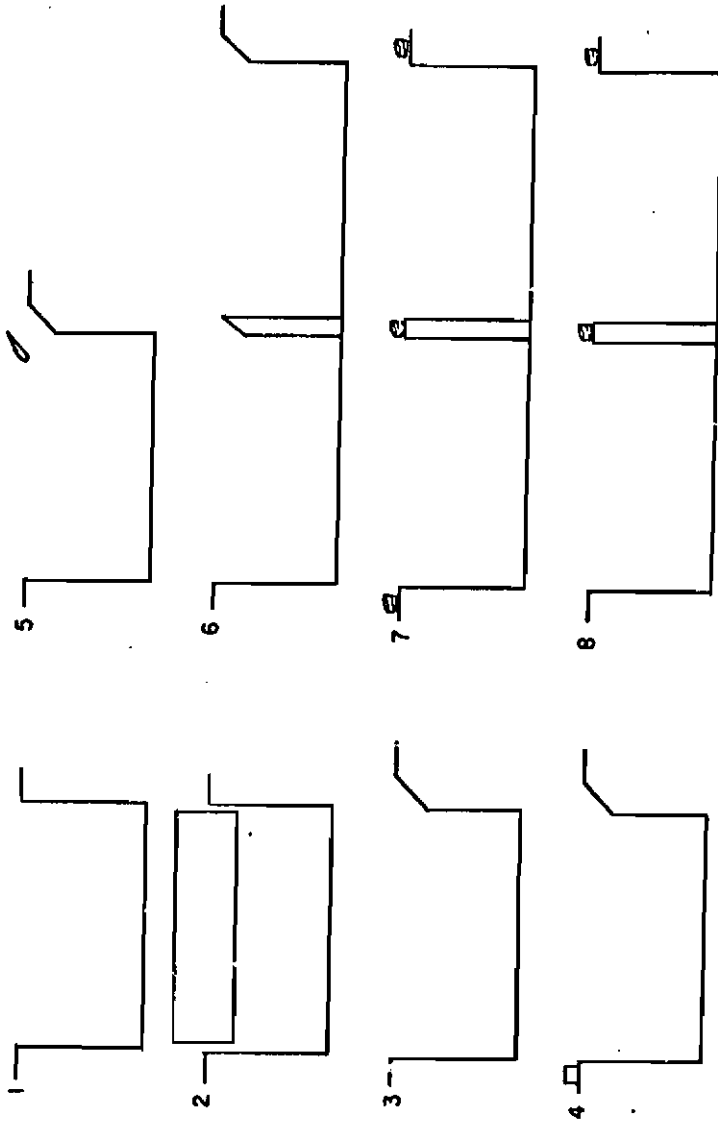

Figure 3. Cavity Configurations Tested: (1) Basic Cavity, (2) Doors, (3) Doors and Trailing Edge Ramp, (4) Doors, Trailing Edge Ramp, and Leading Edge Spoilers, (5) Doors, Trailing Edge Ramp, and Airfoil, (6) Double Cavity, Center Divider Ramp, and Trailing Edge Ramp, (7) Double Cavity, Flow Deflectors on Leading Edge, Center Divider, and Trailing Edge, (8) Double Cavity, Flow Deflectors on Center Divider and Trailing Edge

AFFDL-TR-79-3119

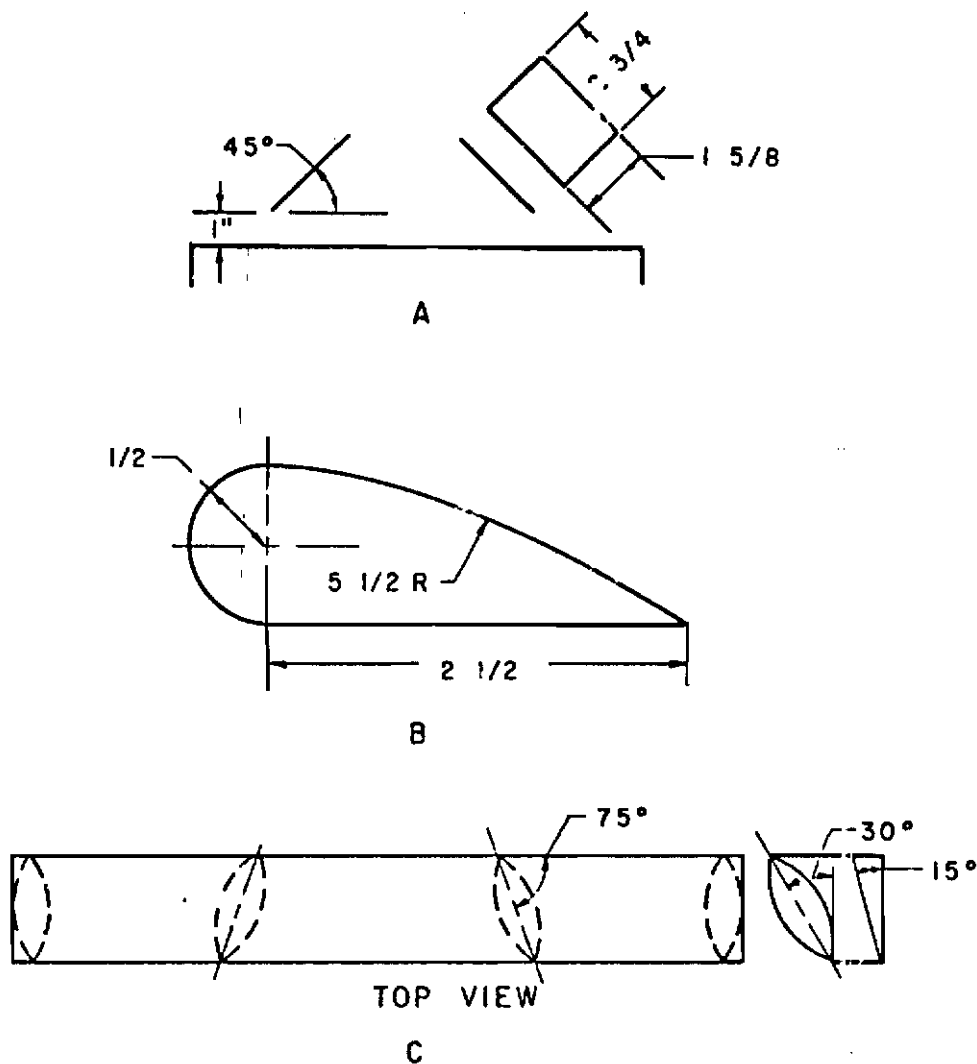

Figure 4. Detailed Sketch of the Suppression Devices: A-Spoiler, B-Airfoil, C-Flow Deflectors

AFFDL-TR-79-3119

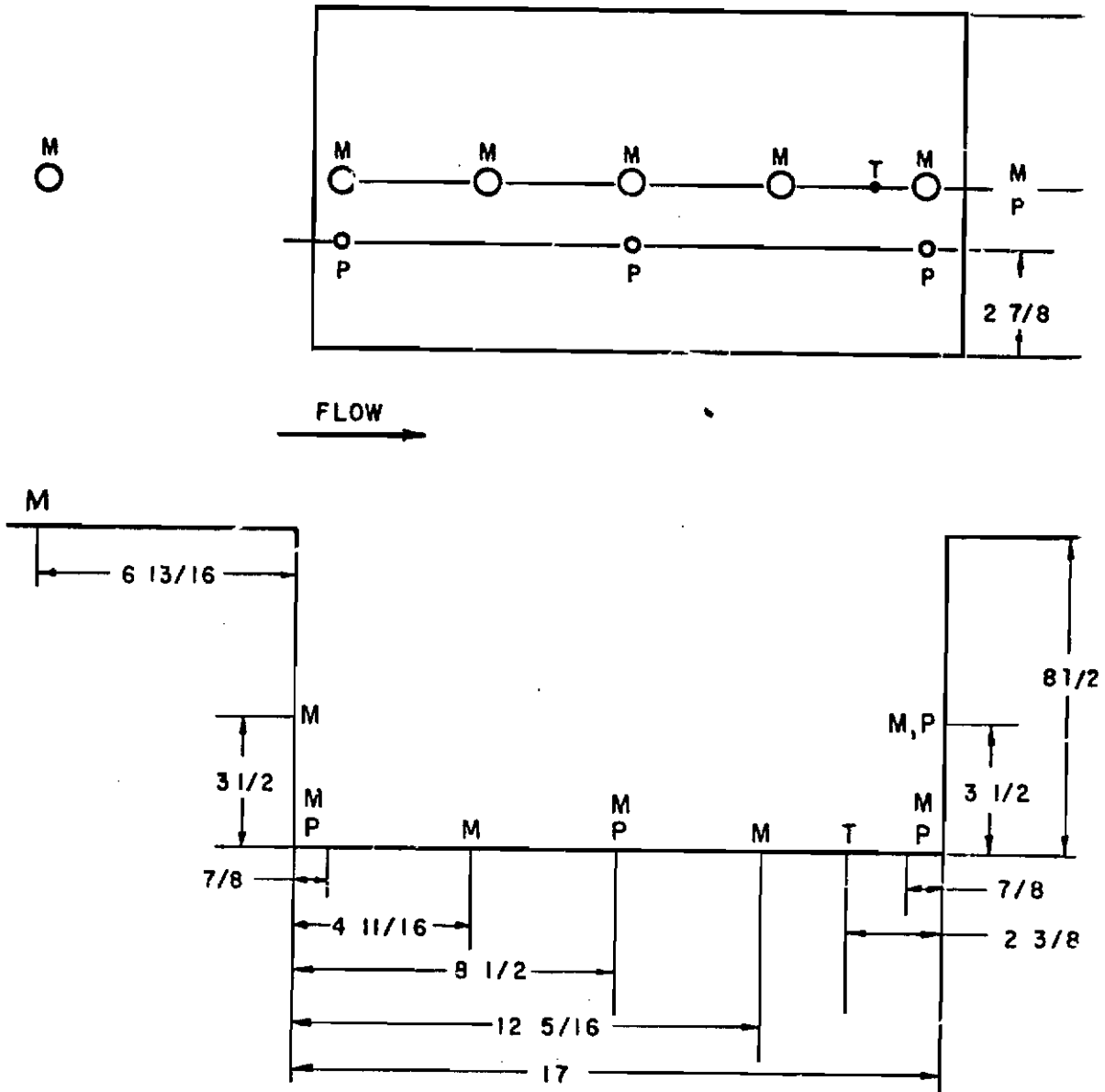

Figure 5. Instrumentation location in the Single Cavity:
M-Microphone, P-Static Pressure Tap, T-Thermocouple

AFFDL-TR-79-3119

located as shown. The microphones were flush-mounted. Figure 6 shows the instrumentation location for the double-cavity configuration. A total of 10 microphones, 8 static pressure taps, and one thermocouple were utilized for this configuration.

3. TEST PROCEDURES

The instrumented cavities were installed in the modified SSU-41 Pod mounted on a triple ejection rack on an RF-4C aircraft as shown in Figure 7. Flight tests were performed at 3,000, 20,000, and 30,000 feet. The Mach number ranges were 0.60 - 0.92, 0.60 - 1.20, and 0.60 - 1.30, respectively. During each flight the aircraft slowly accelerated from the lowest speed to the highest speed and then climbed to the next altitude and started again. All of the flights were flown over the Gulf of Mexico.

AFFDL-TR-79-3119

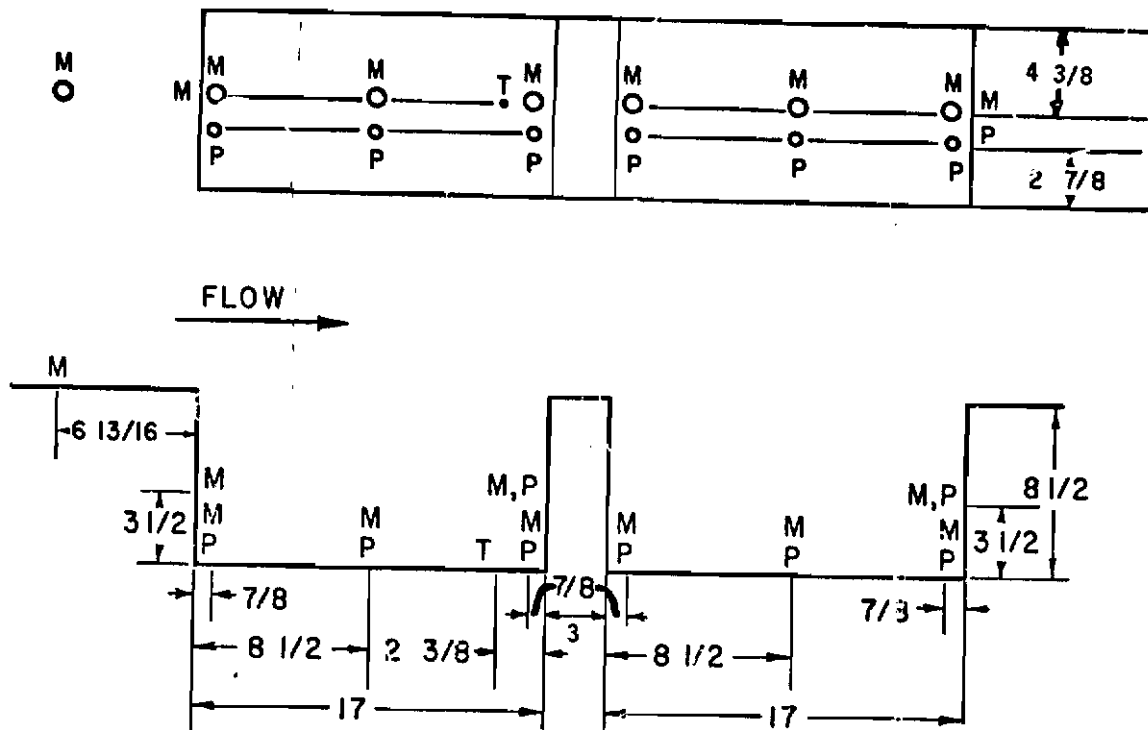

Figure 6. Instrumentation Location in the Double Cavity:
 M-Microphone, P-Static Pressure Tap, T-Thermocouple

AFFDL-TR-79-3119

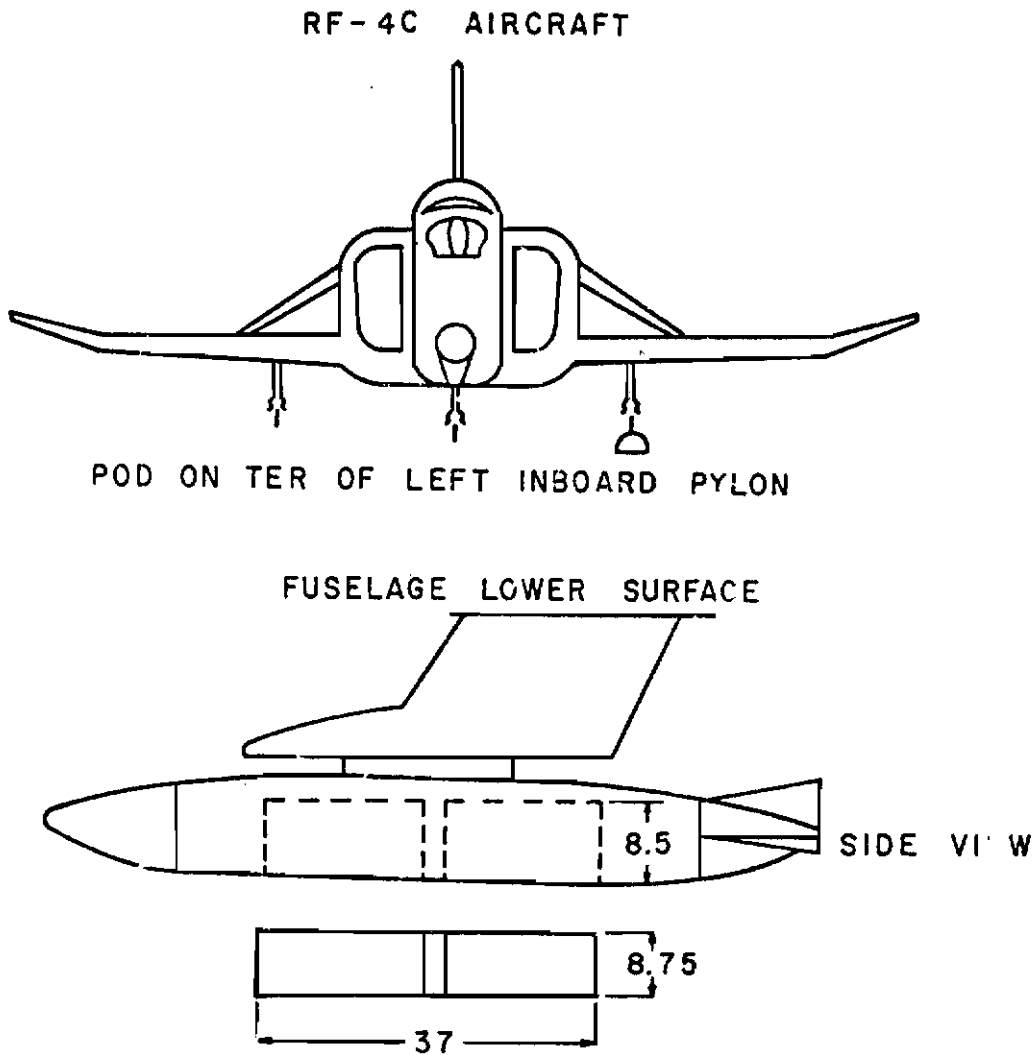

Figure 7. Modified SUU-41 Pod

AFFDL-TR-79-3119

SECTION III
DISCUSSION OF RESULTS

1. CAVITY TEMPERATURE VARIATIONS

To monitor the temperature in the cavity, one thermocouple was installed in each configuration tested. The thermocouple was located as shown in Figure 5. References 3, 4, and 15 show that the temperature in cavities exposed to free-stream flow approaches the free-stream stagnation temperature. Since the ambient temperature was not recorded during the current flight tests, it was impossible to determine if these data follow the same trend. The measurements were made to determine the effect of the suppression devices on the cavity temperature. Again, not knowing the ambient temperatures enters an unknown in comparing the cavity temperature from each of the configurations; that is, the flights were not all flown on the same day. Thus, if the ambient temperature changed significantly during the course of the flight tests, the internal cavity temperature would be affected. However, since all of the flight tests were completed within three weeks, the ambient temperature for the 30,000-foot altitude was considered fairly constant.

Temperature data obtained from the nearest weather station (Apalachicola, Florida) indicated that the ambient temperature at the 30,000-foot altitude varied less than 3°F from the average during the time of the flight tests. Analysis of other sources of temperature data near the flight test area indicates that the temperature variances for Apalachicola are representative of the subject test area.

Temperature results from the 30,000-foot altitude for each of the configurations are presented in Figure 8. Data are presented for Mach numbers from 0.6 to 1.3. The cavity temperatures are seen to decrease at the low Mach numbers and then rapidly increase at the higher Mach numbers. This is the case for nearly every configuration.

As explained in Reference 15, this behavior is essentially a result of the flight test sequence. The flight tests were flown from the lowest altitude to the highest altitude with the aircraft going immediately to

AFFDL-TR-79-3119

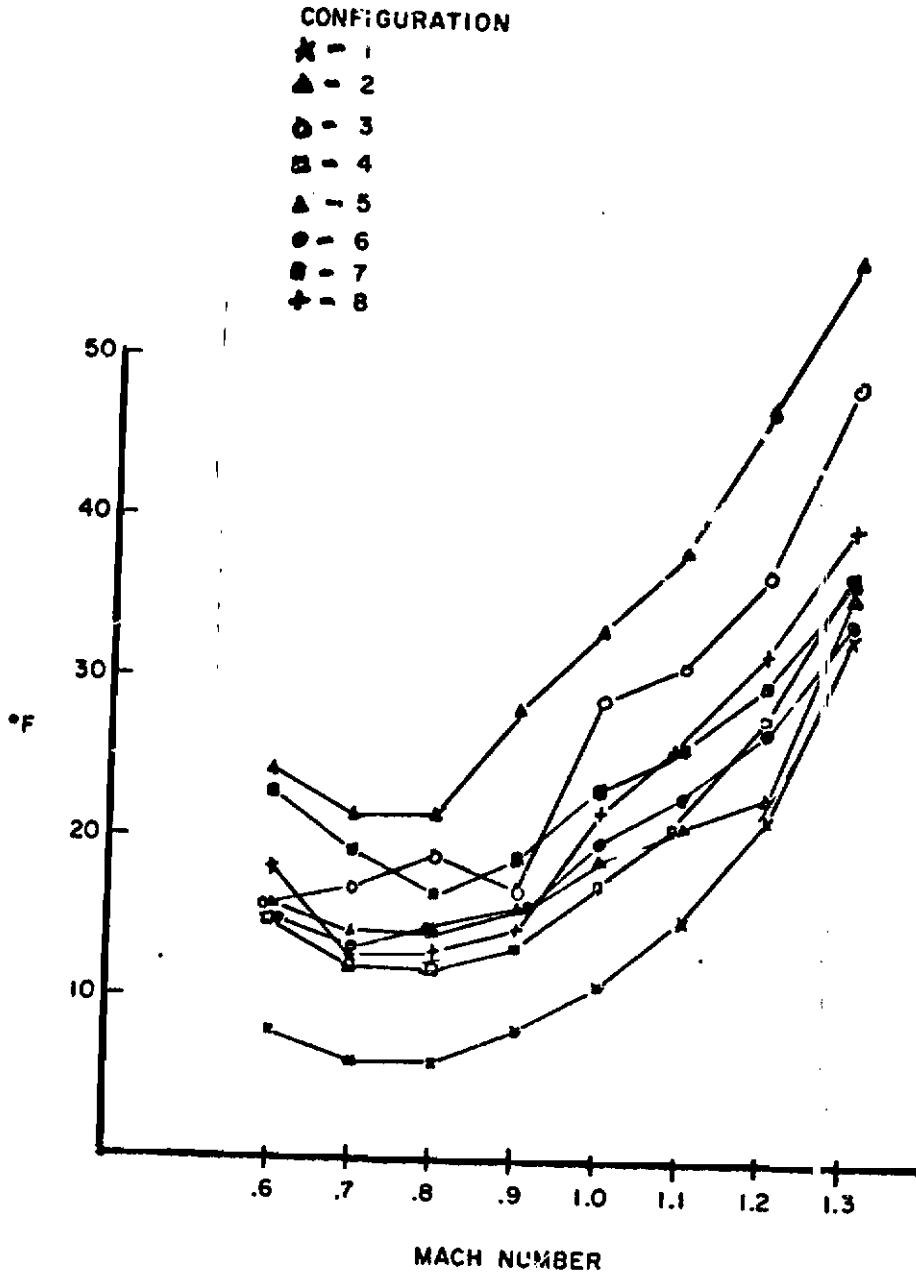

Figure 8. Comparison of the Temperature for Each of the Configurations for the 30,000-Foot Altitude

AFFDL-TR-79-3119

the higher altitude. The stagnation temperature at the 20,000-foot altitude for Mach number 1.2 is approximately 110°F higher than at 30,000 feet for Mach number 0.6. Thus, the cavity wall temperatures are significantly higher than the initial stagnation temperature at the start of the 30,000-foot run since the cavity did not have sufficient soak time at the speed and altitude. As the speed increases, the stagnation temperature increases and exceeds the temperature of the cavity, and the cavity temperature starts to increase and continues to rise for the remainder of the flight.

It is of interest to note the suppression device effect on the cavity temperature. Comparing the results at the maximum speed, one sees that most of the configurations displayed about the same temperature. Two of the configurations show temperatures well above the others. These are ramp and the ramp airfoil configurations. The conclusion drawn is that these configurations result in less turbulence in the cavity; thus, the temperature more closely approaches the stagnation temperature.

2. STATIC PRESSURES

In order to determine the effects of the suppression devices on the static pressure distribution in the cavities, they were instrumented with static pressure ports. Each cavity had four static pressure ports located as shown in Figures 5 and 6. The static pressures measured in flight were obtained via a scanivalve which had its reference port open to the ambient pressure, hence the measured levels were referenced to the local ambient pressure for each flight. The signal from the scanivalve was recorded on magnetic tape and later reduced in the laboratory.

The static pressures for configuration 1, clean single-cavity, are presented in Figure 9. Data are presented for 3,000- and 30,000-foot altitudes for the entire Mach number range of the test. The 3,000-foot altitude data only goes up to Mach number 0.9 which was the upper limit for the aircraft at that altitude. The insert in the figure indicates the relative location of the pressure ports. A comparison of the 3,000- and 30,000-foot data reveal a significant difference between the levels.

AFFDL-TR-79-3119

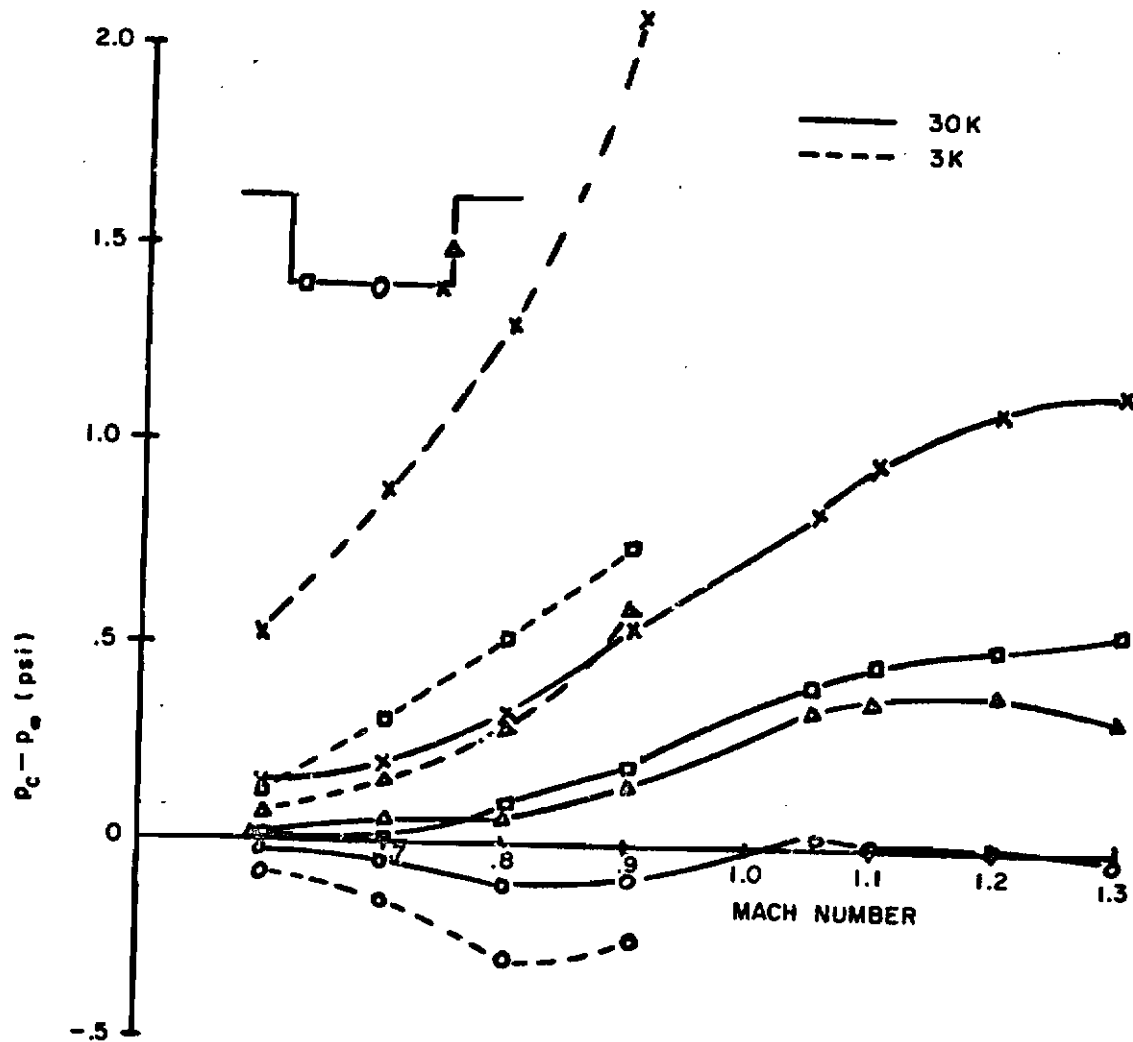

Figure 9. Static Pressure for the Clean Single-Cavity Configuration

AFFDL-TK-79-3119

This difference can be attributed essentially to the free-stream static pressure. However, normalizing with static pressure still results in the low-altitude data being greater than the high-altitude data.

The Mach-number effect for each port location is also shown in Figure 9. In general, the levels increase with Mach number. At negative pressure locations the pressure decreases some before increasing. The levels for the high altitude tend to show a maximum value at the higher Mach numbers. This is most evident for the results from the rear wall. The variation between the high- and low-altitude results displayed the same trend for each of the cavity configurations tested.

Another way to view the data is its longitudinal variation along the cavity. This was done in Figure 10. Data for four Mach numbers are shown revealing a dramatic variation along the cavity. The static pressures near the center are approximately equal to the free-stream value, while the levels at each end are well above the free-stream value, especially at the higher Mach numbers. These distributions give an indication of the flow pattern in the cavity. That is, for the low-Mach numbers the low-speed vorticity areas in the corners are low pressure and this should be fairly large in comparison to the high-Mach number - high-pressure size.

The static pressures on the rear wall are much lower than those just ahead of it on the floor of the cavity, for there is as much variation of the rear wall as on the floor. The distribution of the static pressure on the rear wall is shown in Reference 11. In Figure 11 the current flight data for Mach number 1.2 is compared to the wind tunnel results of Reference 11. The agreement is good considering the vast differences in test conditions. The levels near the front and rear are reasonably consistent, but the levels near the center tend to be higher for the current data. The levels on the rear wall are nearly the same.

The static pressures in the cavity were altered by the suppression devices. The results for each configuration are compared to a basic case to determine the effect of the devices. Only data for Mach number 0.8 and 1.2 from the 30,000-foot altitude were used. The first configuration

AFFDL-TR-79-3119

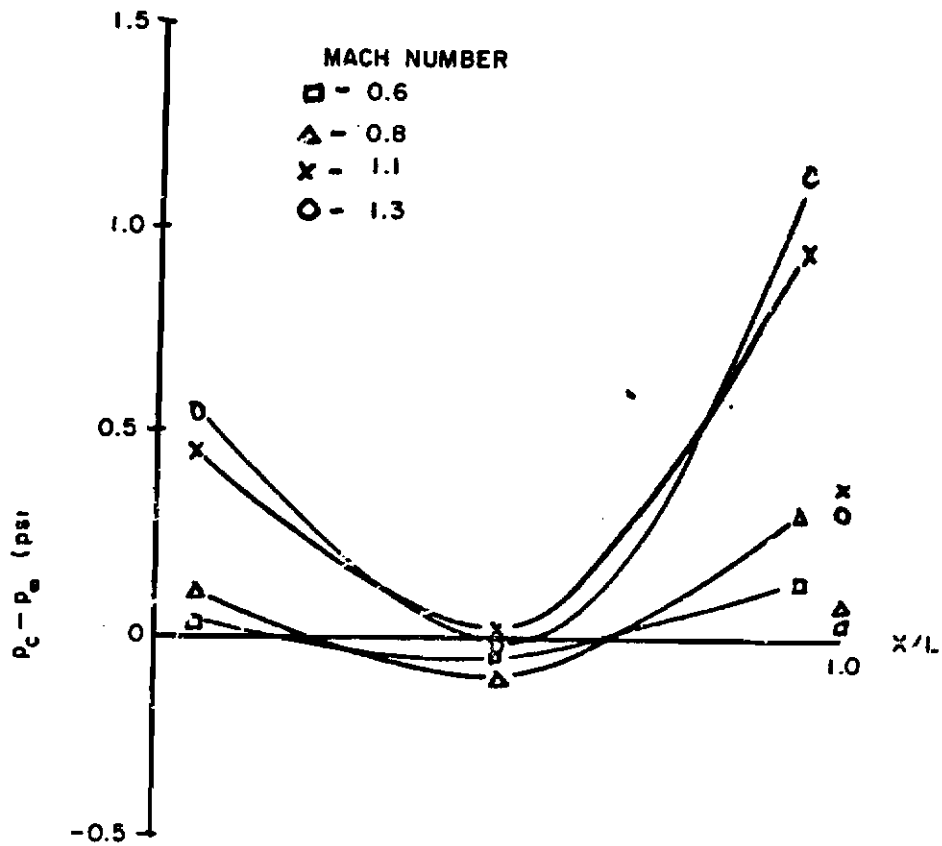

Figure 10. Static Pressure Longitudinal Variation for the Single-Cavity Configuration for 30,000-Foot Altitude

AFFDL-TR-79-3119

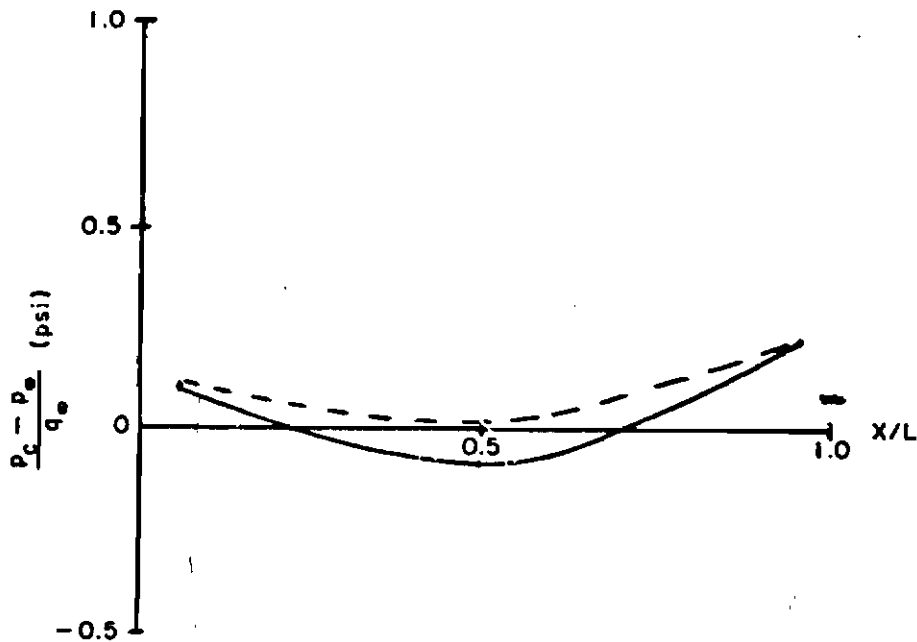

Figure 11. Comparison of Current Flight Data (-----) from the Single Cavity at 30,000 Feet at Mach Number 1.2 to the Wind Tunnel Data (——) in Reference 11

presented in Figure 12 is the single cavity with doors. The doors are not a suppression device but since they were installed for the other configuration, these data should be the baseline to which the others are compared. The doors only had a small affect on the distribution at subsonic speeds but had more affect at supersonic speeds as seen in Figure 12. At Mach number 1.2 the static pressure at the front remained the same while it was increased at the center and decreased at the rear. The real wall pressure decreased.

The first suppression device considered is the ramp. Figure 13 shows a comparison of the data from the single cavity with door configurations, with and without a ramp. The affect on the distribution is nearly the same for subsonic and supersonic speeds. The levels at each end of the cavity decreased, except for Mach number 0.8 at the front, and increased at the center. This could be interpreted as a reduction of the vorticity in the cavity since the distribution is more uniform.

AFFDL-TR-79-3119

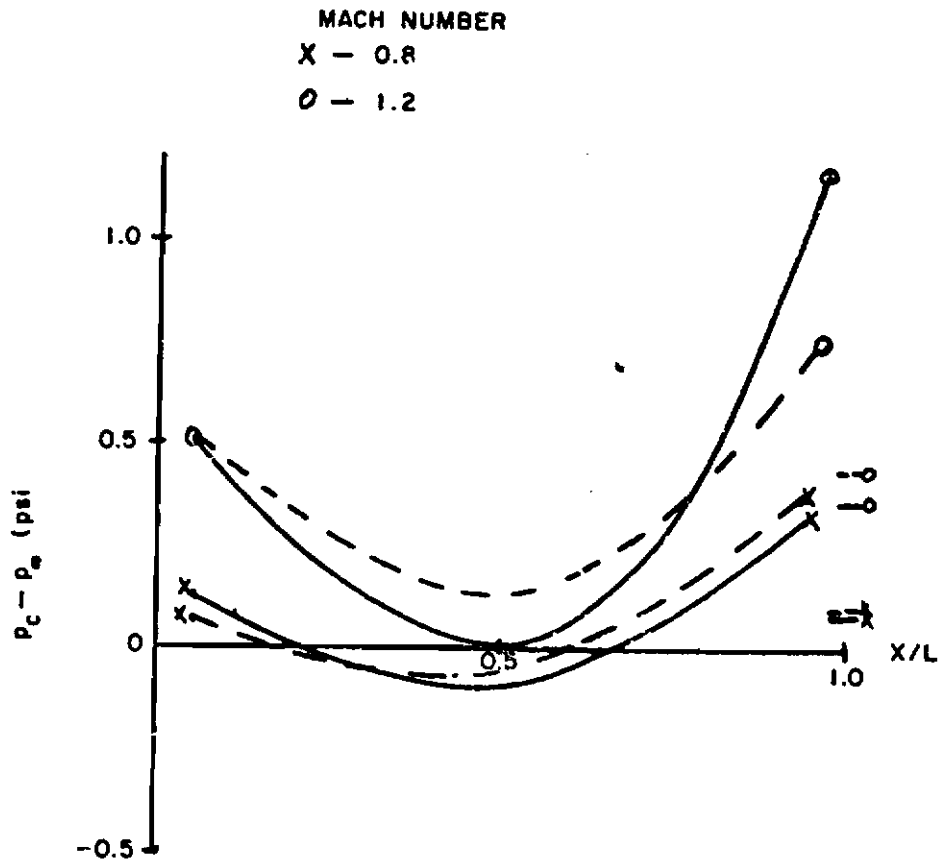

Figure 12. Comparison of Static Pressure Distribution for the Single Cavity with Doors (----) and without Doors (—) for 30,000-Foot Altitude

AFFDL-TR-79-3119

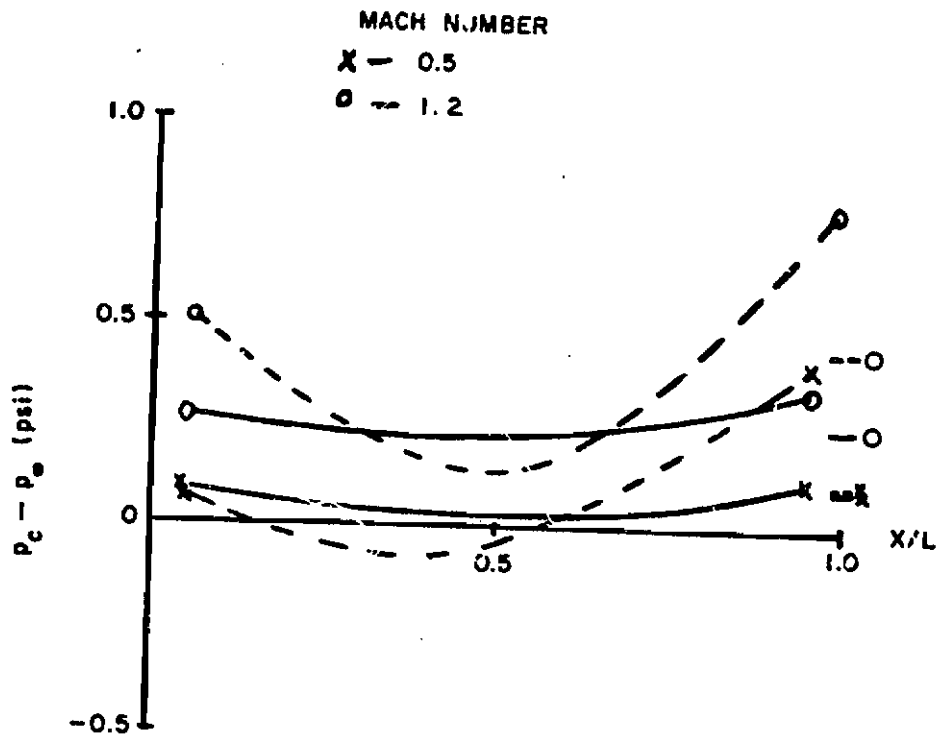

Figure 13. Comparison of the Static Pressure Distribution for the Single Cavity with Doors Configuration with a Ramp (—) and without a Ramp (----) for 30,000-Foot Altitude

The next configuration considered is the ramp-spoiler. These results are shown in Figure 14 along with the baseline case of single cavity with doors. Results from all four measurement locations decreased. The magnitude of reduction for the supersonic speed is much greater than for the subsonic speed. This could be an indication that the ramp-spoiler is more effective at the higher speeds.

Figure 15 displays the ramp-airfoil configuration results. Subsonic data are not available due to anomalies in the data acquisition system. The static pressure at the front was reduced and at the center it was increased while at the rear it was reduced only a small amount.

AFFDL-TR-79-3119

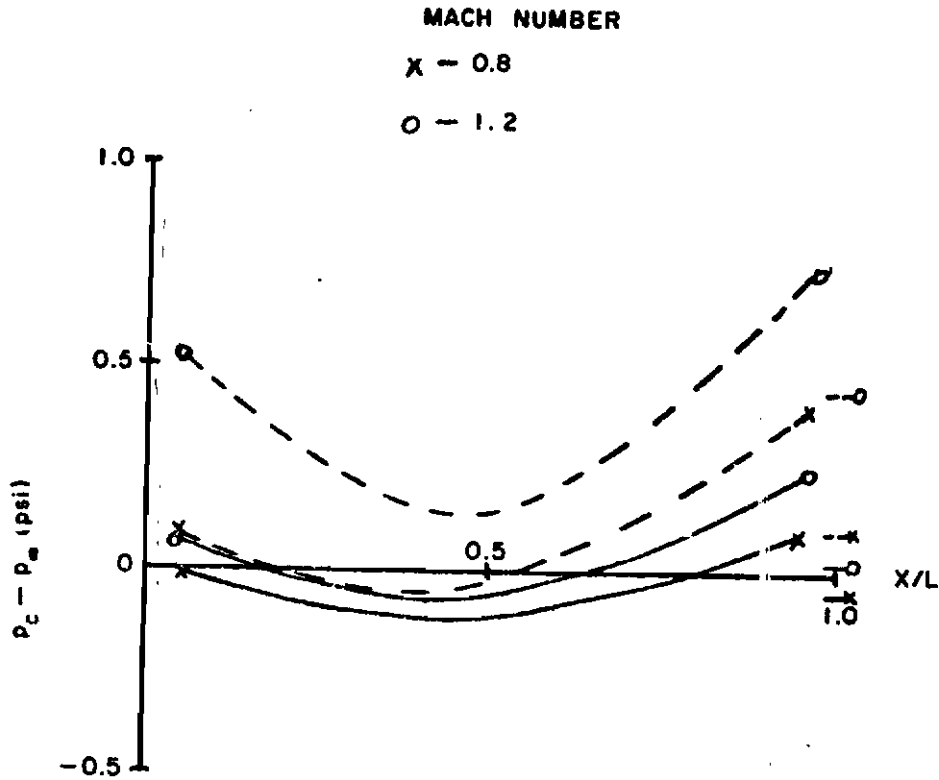

Figure 14. Comparison of the Static Pressure Distribution for the Single Cavity with Doors Configuration with (—) and without (----) a Ramp and Spoiler for 30,000-Foot Altitude

AFFDL-TR-79-3119

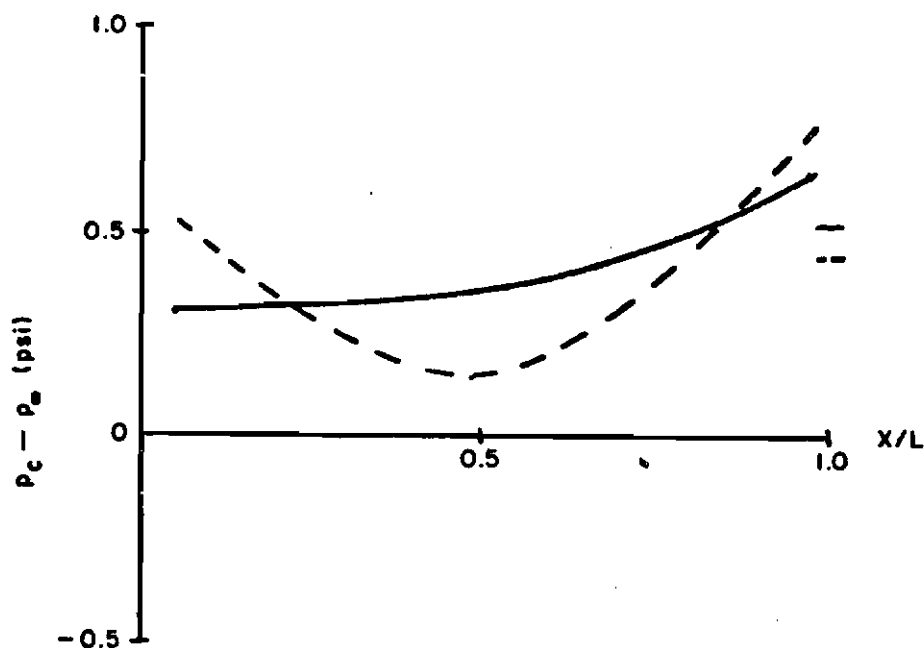

Figure 15. Comparison of the Static Pressure Distribution for the Single Cavity with Doors Configuration with (—) and without (-----) a Ramp and Airfoil for 30,000-Foot Altitude and Mach Number of 1.2

The next configuration discussed is the double cavity with doors and ramp on both cavities. Again, the baseline case is the single cavity with doors. It is used for each of the double cavities. Figure 16 shows the results for both fore and aft cavities. The distribution in the fore cavity is nearly the same as that shown in Figure 13 for the single cavity with ramp. The main difference is for Mach number 1.2. The levels in Figure 16 are lower than those in Figure 13. The influence of the aft cavity on the fore cavity appears to be greater at the supersonic speeds. The distribution in the aft cavity is seen to be different from the fore cavity. The levels at the front and center are lower but at the rear they are about the same. The airflow over the aft cavity is definitely altered from that over the fore cavity and thus is expected to have a different pressure distribution in it.

AFFDL-TR-79-3119

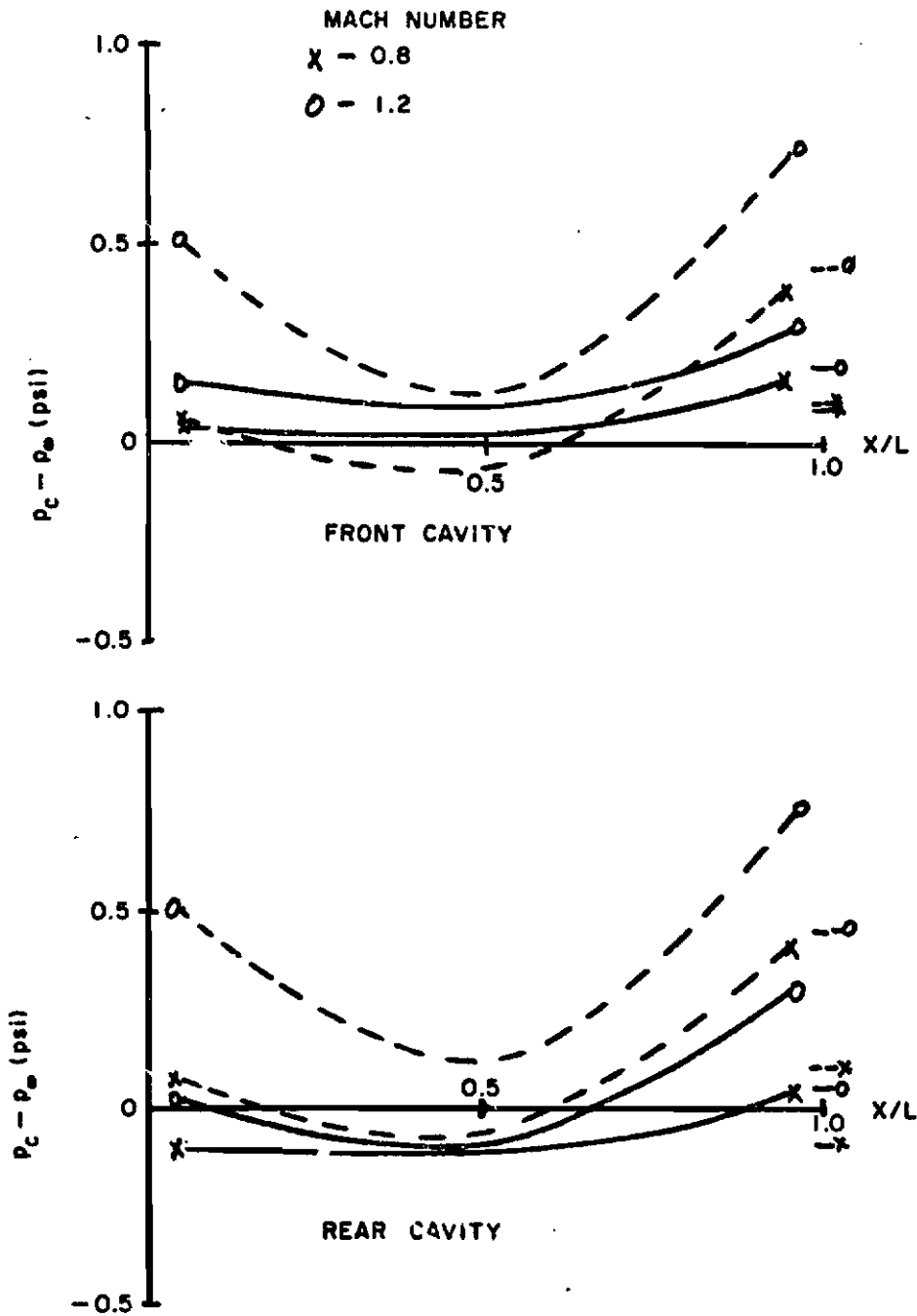

Figure 16. Comparison of the Static Pressure Distribution in the Single Cavity with Doors Configuration (-----) to the Double Cavity with Ramp on each Configuration (——) for 30,000-Foot Altitude

AFFDL-TR-79-3119

The results from the double-cavity configuration with the fore-center-aft deflectors are presented in Figure 17. An interesting result is observed in the forward cavity. The static pressure distribution is maximum at the center of the cavity instead of the rear. Essentially, the same levels were measured at both subsonic and supersonic speeds. An explanation for this variation is not readily apparent. The aft cavity has distributions consistent with the other configurations. The levels in the aft cavity are nearly equal to the free-stream value at the front and center and somewhat greater at the rear.

The last configuration presented is the double cavity with center and aft deflectors. These results are shown in Figure 18. The distribution in the forward cavity was changed only a little while that in the rear was significantly altered. For the deflector to be effective it must be at the leading edge of the cavity. Note that in the rear cavity the supersonic levels are lower than the subsonic ones for much of the cavity. The deflectors are apparently more effective at the higher speeds.

3. FLUCTUATING PRESSURE LEVEL VARIATIONS

Past research has shown that the fluctuating pressure levels in cavities can be significantly affected by the addition of suppression devices. An early example of suppressing the environment is given in Reference 11. Three different size spoilers were investigated. They were installed at the leading edge of the cavity perpendicular to the flow. Suppression as high as 26 dB in the peak level was obtained from the best device. Rossiter concluded that the pressure fluctuations may be suppressed by fixing a small spoiler ahead of the cavity. One must use caution in generalizing his conclusion, mainly because his results were for only one length-to-depth ratio ($L/D=1$) and the model size was fairly small ($L=8"$, $D=8"$). There is still concern that small scale results cannot be directly applied to full scale configurations. Frequencies have been shown to scale reasonably well with a Strouhal number based on cavity length but the amplitudes do not scale well.

A more recent and more extensive investigation into the effectiveness of suppression concepts is presented in Reference 3. Numerous concepts were evaluated by means of water table tests, low-speed open air jet,

AFFDL-TR-79-3119

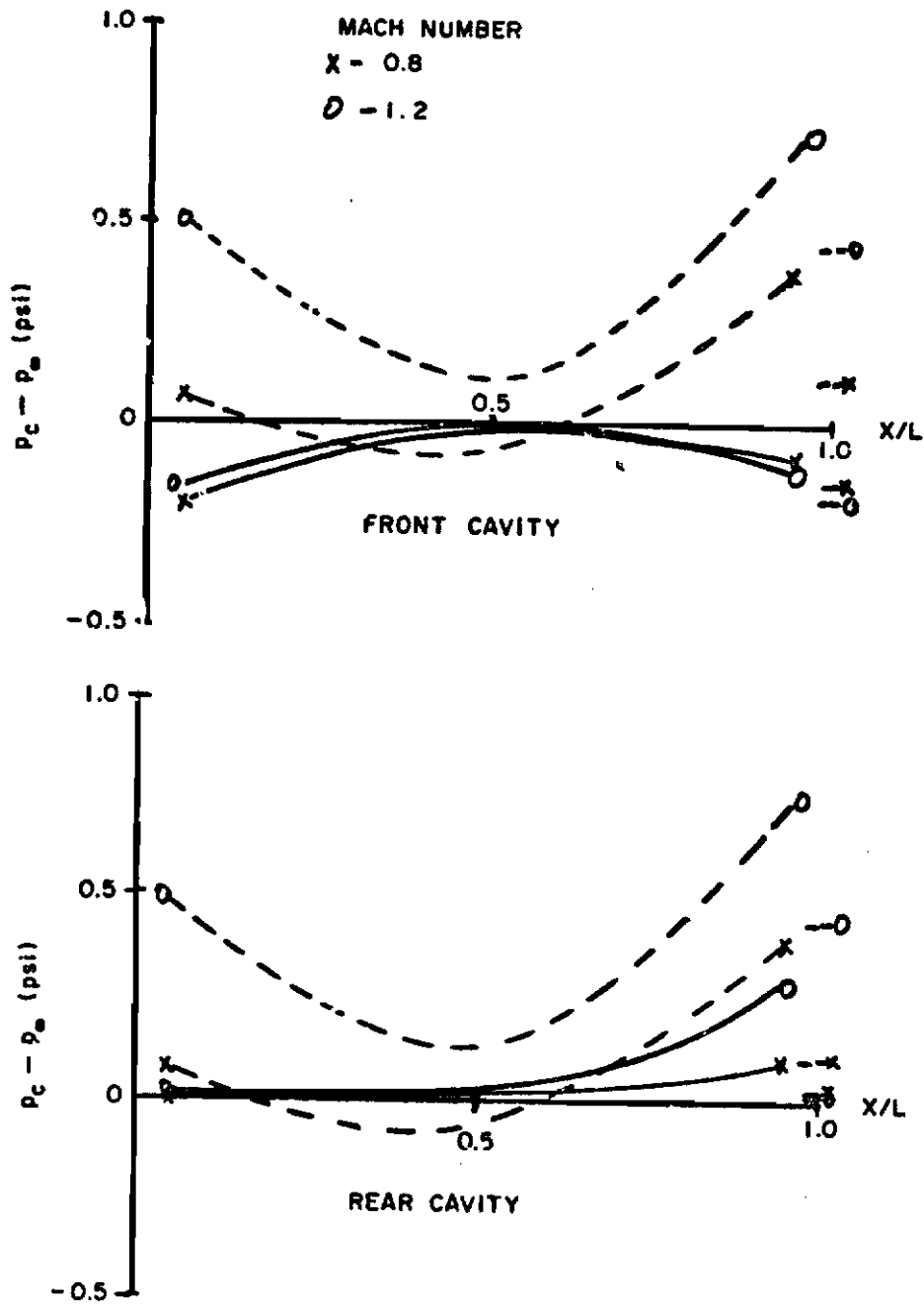

Figure 17. Comparison of the Static Pressure Distribution in the Single Cavity with Doors (-----) to the Double Cavity with Fore-Center-Aft Deflectors Configuration (——) for 30,000-Foot Altitude

AFFDL-TR-79-3119

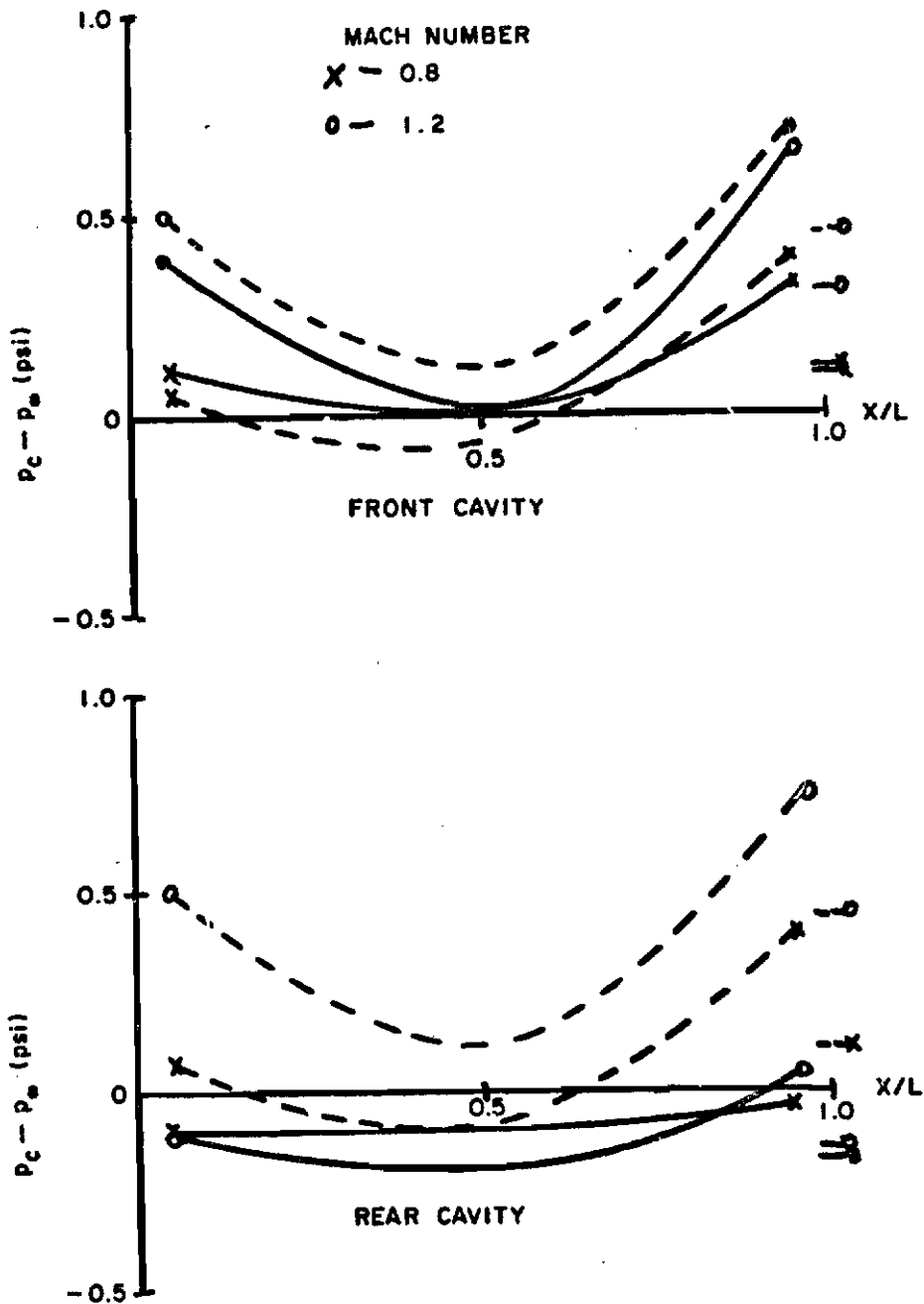

Figure 18. Comparison of the Static Pressure Distribution in the Single Cavity with Doors (-----) to the Double Cavity with Center and Aft Deflectors (——) for 30,000-Foot Altitude

AFFDL-TR-79-3119

and large wind tunnel tests. Four of the numerous concepts tested were shown to be successful. These four are shown in Figure 19. The effectiveness of the concepts are shown in Figures 20 through 22. Reductions as large as 25 dB were measured. As seen in Figure 3 these concepts were included in the current flight tests. The cavities tested were instrumented with microphones to measure the fluctuating pressure levels which were used to evaluate the effectiveness of the suppression concepts. The microphones were located in the cavities as illustrated in Figures 5 and 6. The results are presented as one-third octave band spectra. Due to anomalies in the data acquisition system, fluctuating pressure data were not obtained for configurations 7 and 8 (see Figure 3).

Figures 23 through 27 present spectra from the single basic cavity. The data in Figure 23 are from along the floor of the cavity for a Mach number 0.8 and 3,000-foot altitude. The narrow band energy at the modal frequencies is very pronounced for all locations on the floor. The peak levels occur at the second modal frequency for all locations. However, for other Mach numbers this is not always the case as will be shown below. One notes that there is a significant decrease, approximately 18 dB, in the maximum level at specific locations. This was anticipated because of the standing waves that exist in flow-induced cavity pressure oscillations. These standing waves have been documented in References 3, 4, and 15. Figure 24 illustrates the longitudinal variations of the resonant peaks for data from the 30,000-foot altitude. Maximum levels occur at the fore and aft bulkheads with the lowest levels at the center. As with the 3,000-foot data, the spread in the 30,000-foot data is also approximately 18 dB. The data from the other configurations showed similar longitudinal variations.

The variation of the levels with Mach number is illustrated in Figure 25. The levels in general increase with increasing Mach number. The magnitude of the increase is greater at the higher frequencies (above 500 Hz) than the lower. Note that the first and second modal frequencies do not display the same Mach number effect. The second modal frequency amplitude increases with increasing Mach number but the first modal frequency amplitude show a maximum level near Mach number 0.8.

AFFDL-TR-79-3119

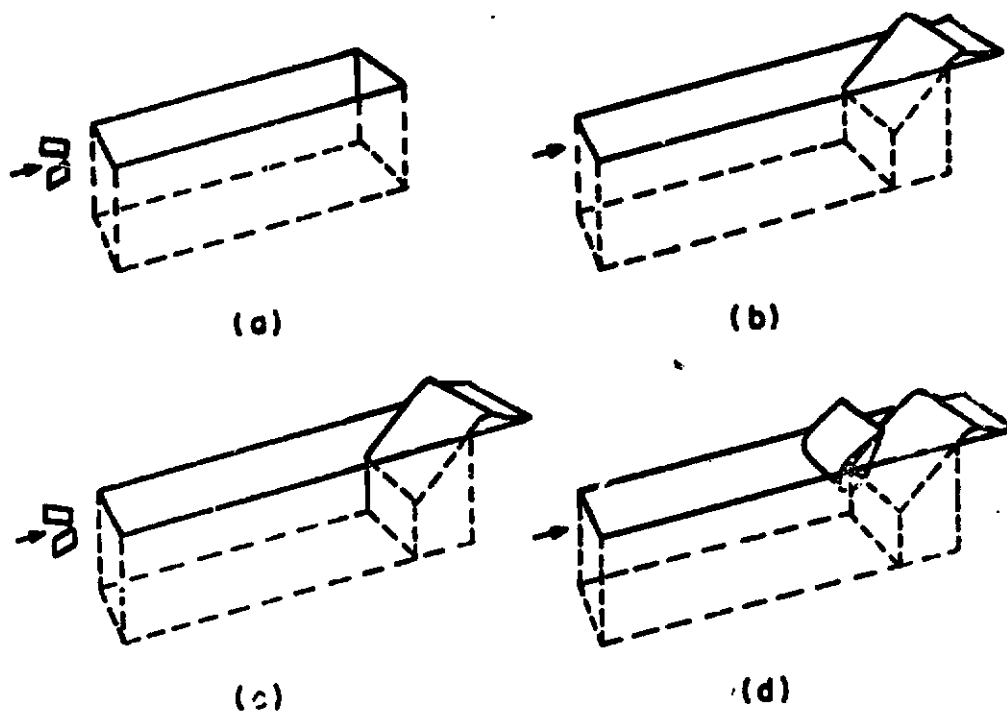

Figure 19. Perspective Representation of Successful Suppression Concepts

AFFDL-TR-79-3119

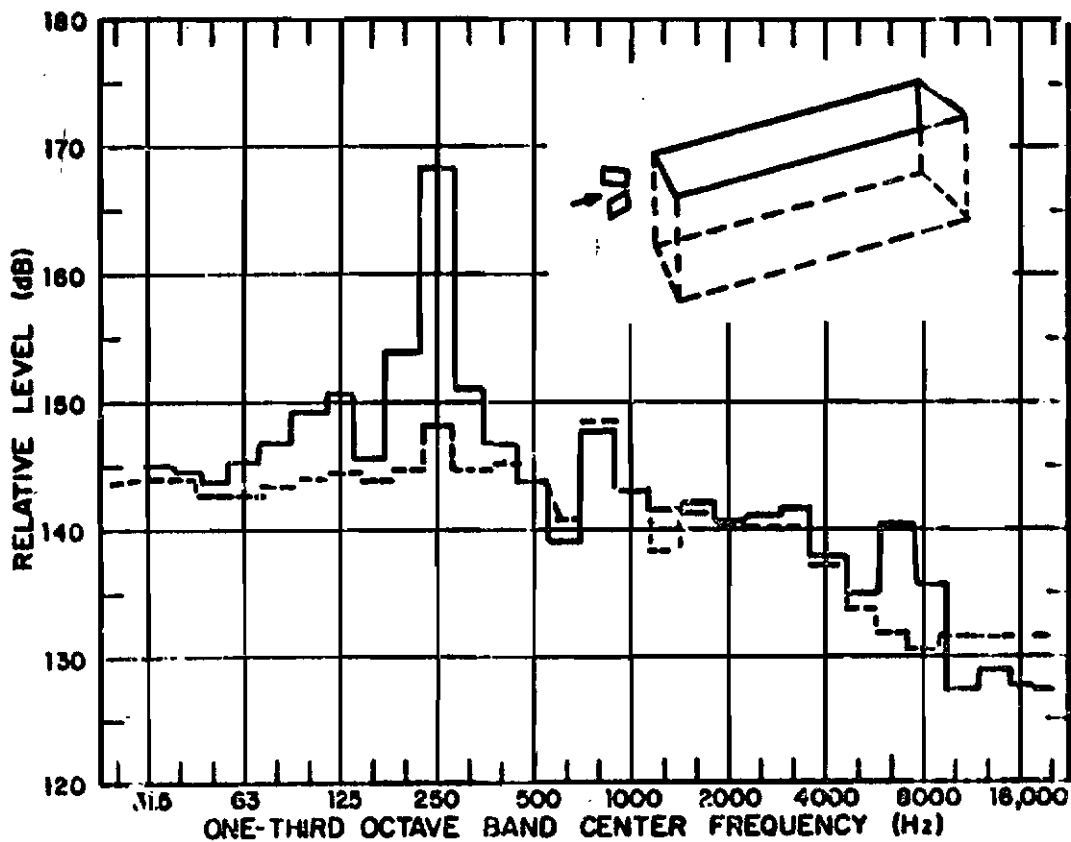

Figure 20. Effect of Upstream Spoilers at 45° Angle of Attack on Leading-Edge Bulkhead Pressure Signal: $M_\infty = 0.9$; $L/D = 2.3$ (continuous line refers to unmodified cavity)

AFFDL-TR-79-3119

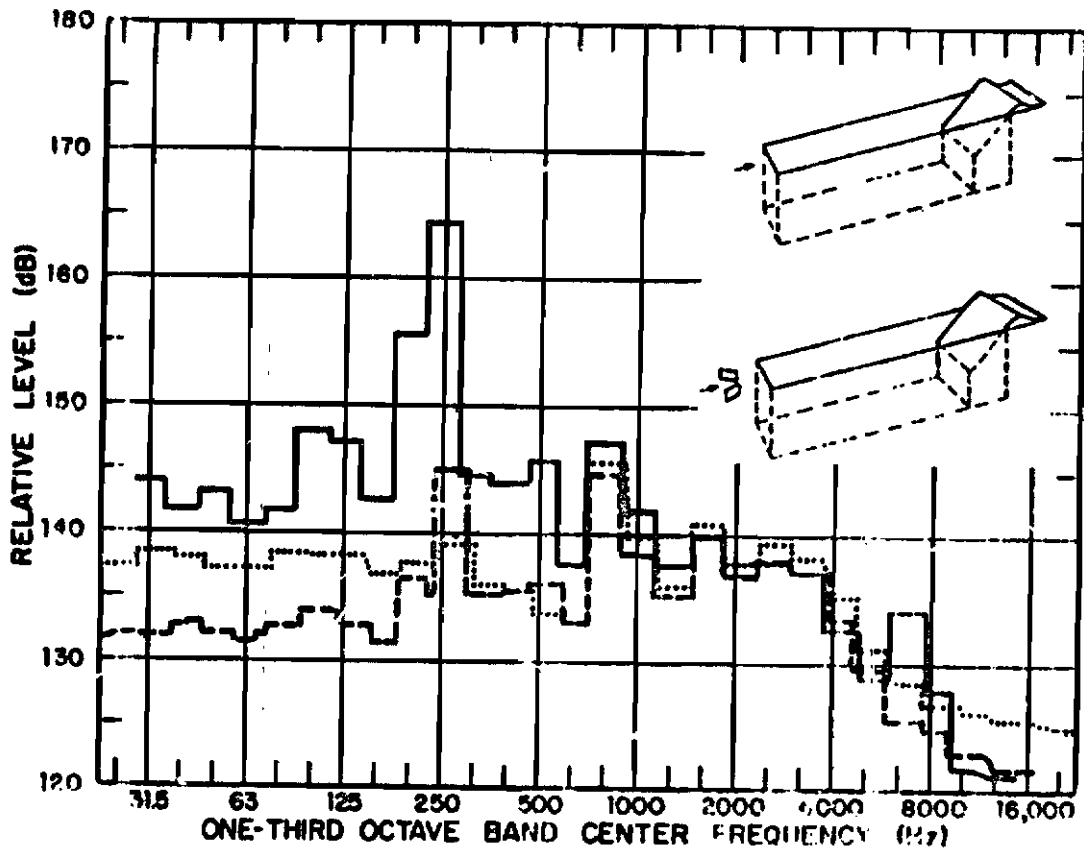

Figure 21. Effect of Training-Edge Slant with and without Upstream Spoilers on Leading-Edge Bulkhead Pressure Signal: $M_{\infty} = 0.8$; $L/D = 2.3$ (continuous line refers to unmodified cavity; dashed line refers to trailing edge slant only; dotted line refers to combination of trailing-edge slant and upstream spoilers)

AFFDL-TR-79-3119

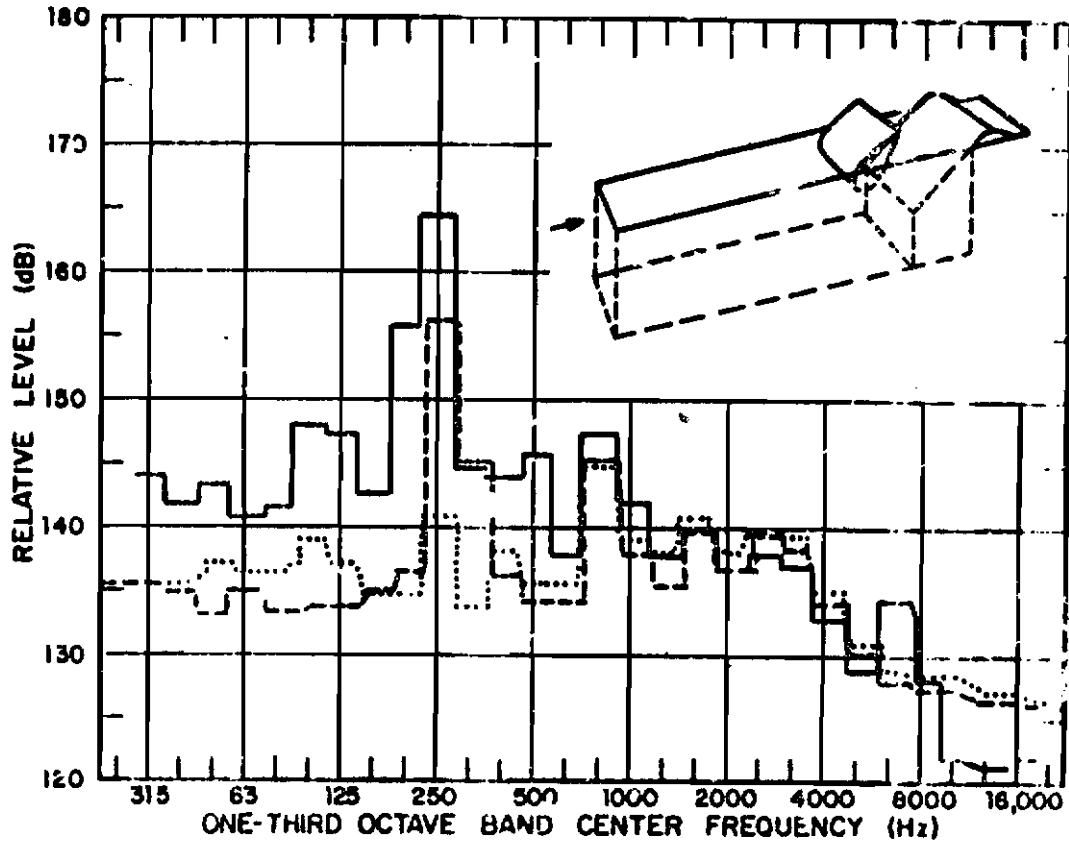

Figure 22. Effect of Trailing-Edge Slant in Combination with a Detached Cowl on Leading-Edge Bulkhead Pressure Signal: $M_0 = 0.8$; $L/D = 2.3$ (continuous line refers to unmodified cavity; dashed line refers to cowl trailing edge located at cavity mouth level; dotted line refers to cowl trailing edge located 2 in. above cavity mouth level).

AFFDL-TR-79-3119

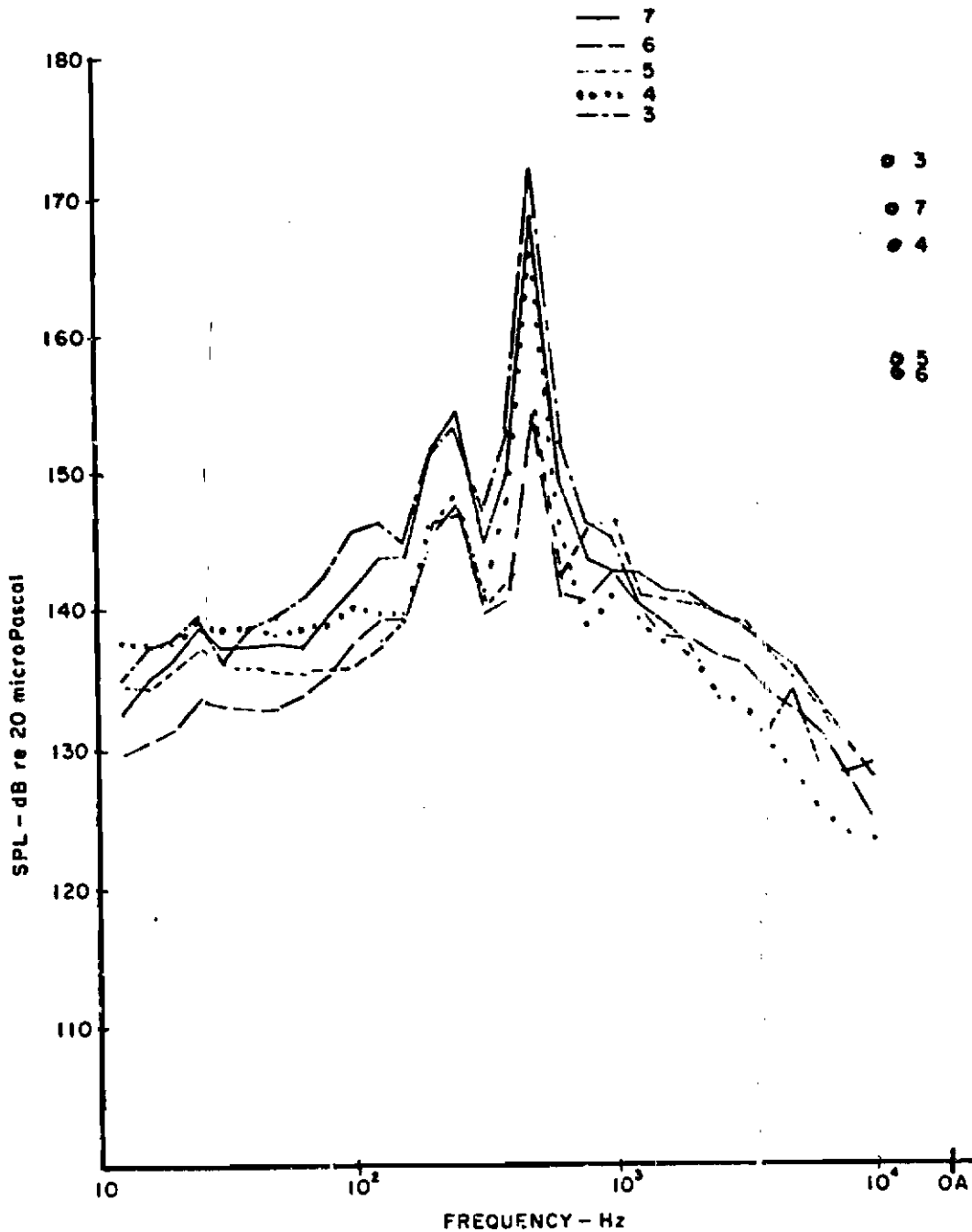

Figure 23. One-Third Octave Band Spectra for the Single Basic Cavity for Mach Number 0.8 and 3,000-Foot Altitude

AFFDL-TR-79-3119

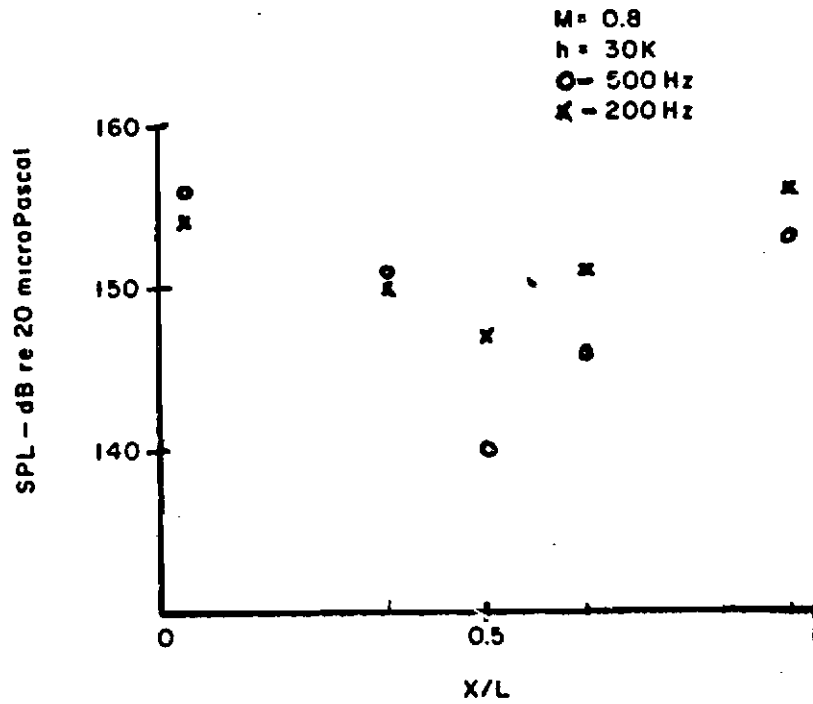

Figure 24. Longitudinal variation of the Modal Frequency Amplitudes

AFFDL-TR-79-3119

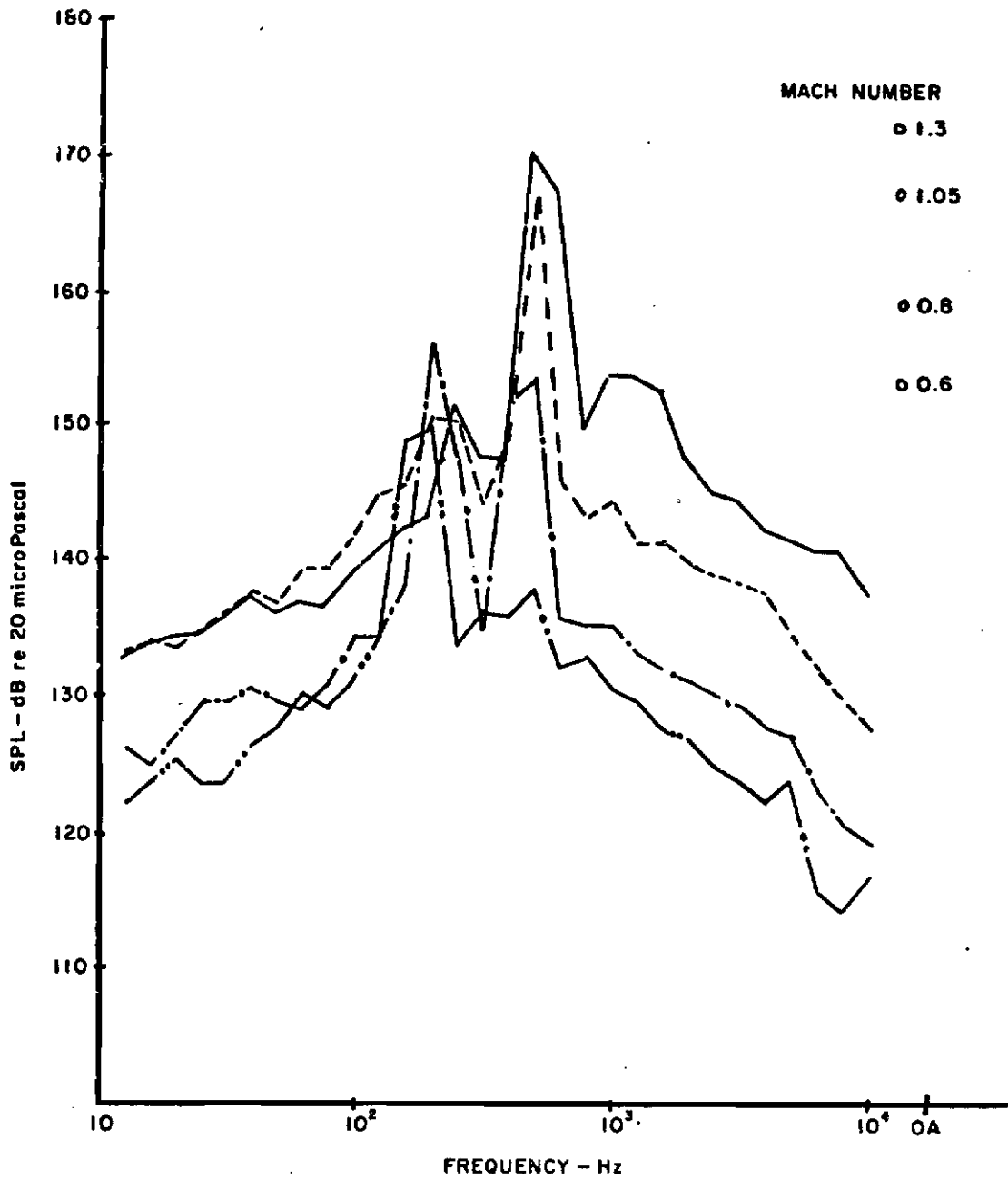

Figure 25. One-Third Octave Band Spectra From the Single Basic Cavity From Microphone 7 for 30,000-Foot Altitude

AFFDL-TR-79-3119

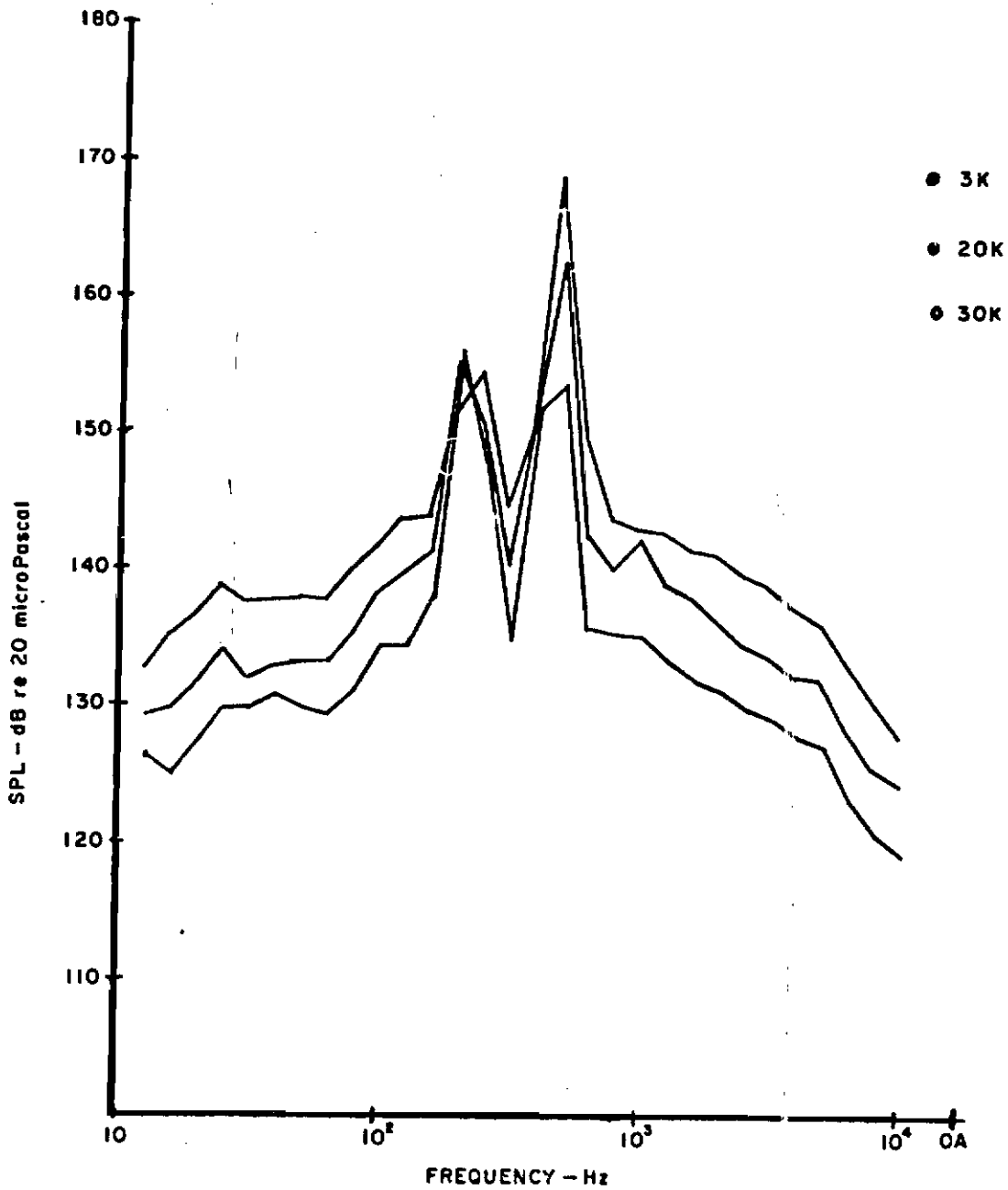

Figure 26. One-Third Octave Band Spectra from the Single Basic Cavity From Microphone 7 for Mach Number 0.8 for 3,000- 20,000- and 30,000-Foot Altitudes

AFFDL-TR-79-3119

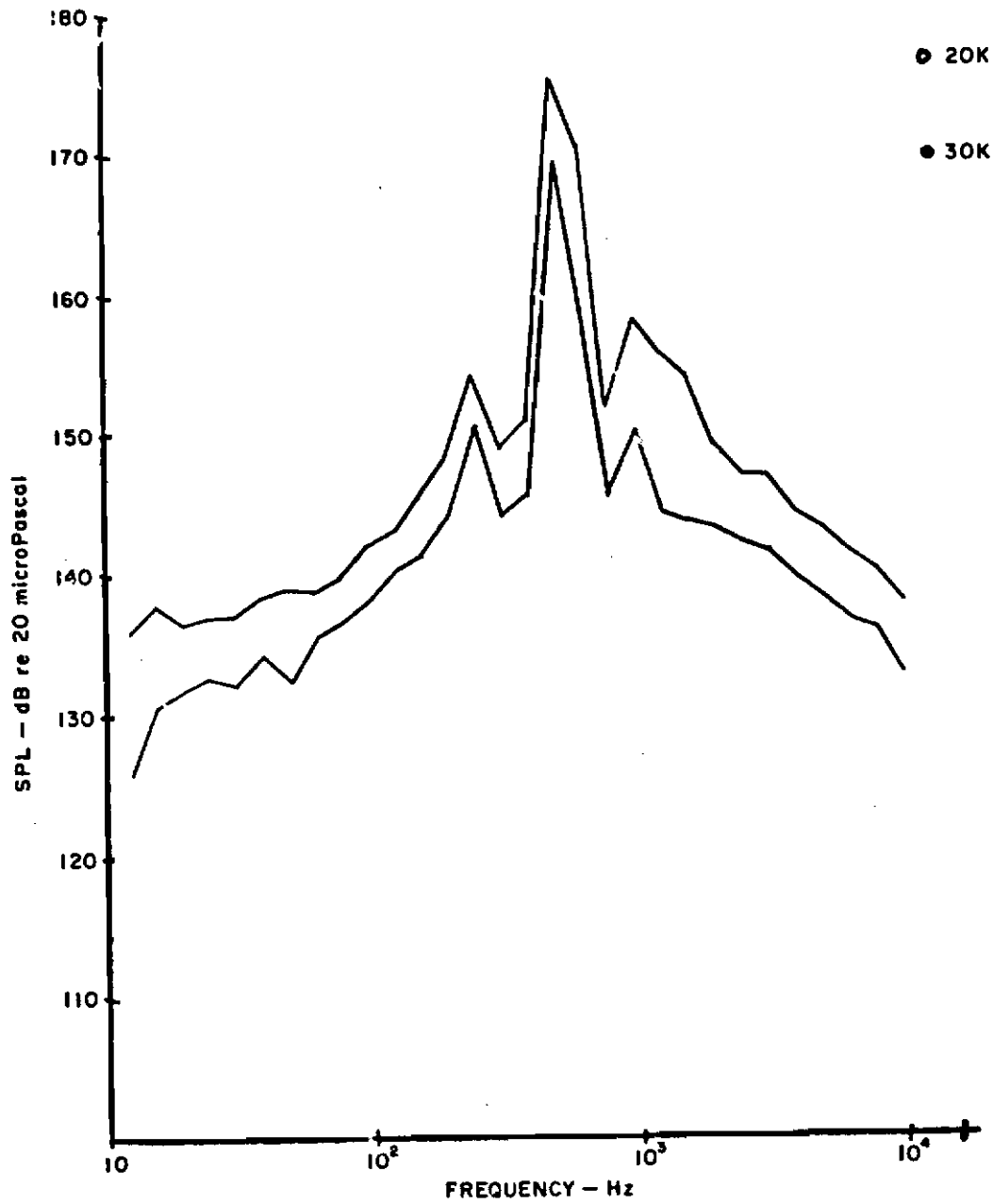

Figure 27. One-Third Octave Band Spectra from the Single Basic Cavity from Microphone 7 for Mach Number 1.20 for 20,000- and 30,000-Foot Altitudes

AFFDL-TR-79-3119

The reason for the difference is that the second modal frequency is not excited at the lower Mach numbers while the first modal frequency is not excited at the higher Mach numbers. This excitation phenomenon is not sufficiently understood to explain the Mach effect on the modal amplitude.

Flow-induced pressure oscillations in shallow cavities have been shown to scale with free-stream dynamic pressure. Spectra from the three test altitudes for the single basic cavity configurations are shown in Figure 26. The data are for a subsonic Mach number of 0.8. Normalizing with dynamic pressure accounts for 5 dB between the 3,000-foot and 20,000-foot data; 4 dB between 20,000-foot and 20,000-foot altitude data. The data are considered to scale well at most frequencies. Supersonic data, Mach number 1.2, are presented in Figure 27. Data for the 3,000-foot altitude are not available at this Mach number due to flight limitations. It is evident that the levels scale reasonably well at supersonic Mach numbers also. The data from all of the test configurations displayed, in general, good dynamic pressure scaling.

Figures 28 and 29 illustrate the effect the doors had on the levels in the cavity. Comparisons at Mach number 0.8 are seen in Figure 28. It is evident that the doors had a very small effect at almost all frequencies. The effect is somewhat greater at Mach number 1.2 as shown in Figure 29. The broadband levels were altered only 1-3 dB, but the first and third modal frequency amplitudes were altered 6-7 dB. The first modal frequency amplitude was increased by that amount, while the third was lowered by the same amount. The second modal frequency amplitude was not affected. Even though there were substantial variation at their frequencies, the overall level is the same for both configurations.

Figures 30 and 31 show the effectiveness of the aft bulkhead ramp in suppressing the internal levels. Mach number 0.8 data are presented in Figure 30. The second modal frequency amplitude is suppressed 20 dB, while the first is only suppressed 7 dB. The broadband levels are generally lowered 6-7 dB. In essence, it could be concluded that the first modal frequency amplitude was not suppressed at all since the broadband levels were lowered by the same amount. Regardless of how it is

AFFDL-TR-79-3119

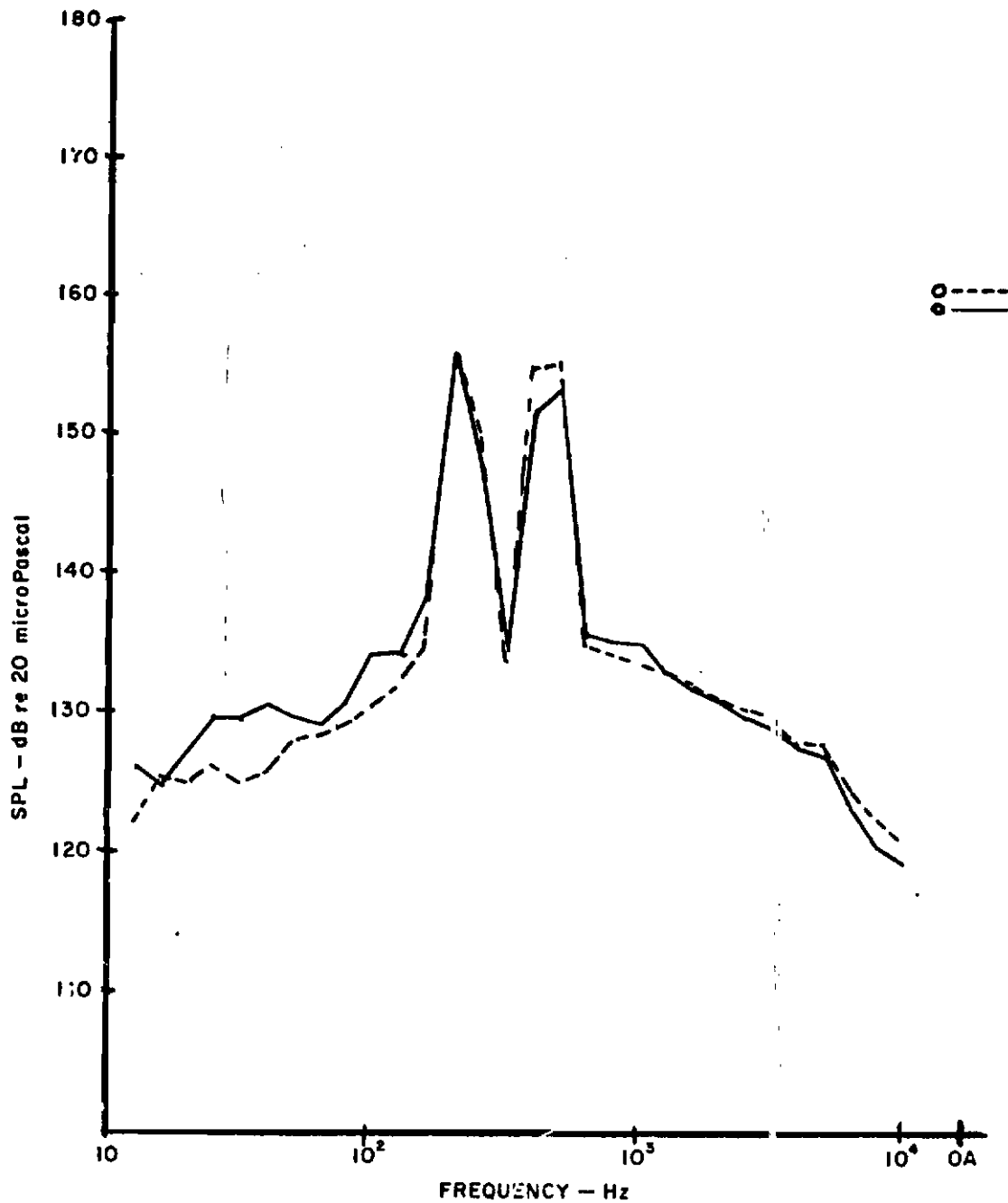

Figure 28. Comparison of the Spectra from the Single Cavity with (-----) and without: (——) Doors for Mach Number 0.8 and 30,000-Foot Altitude

AFFDL-TR-79-3119

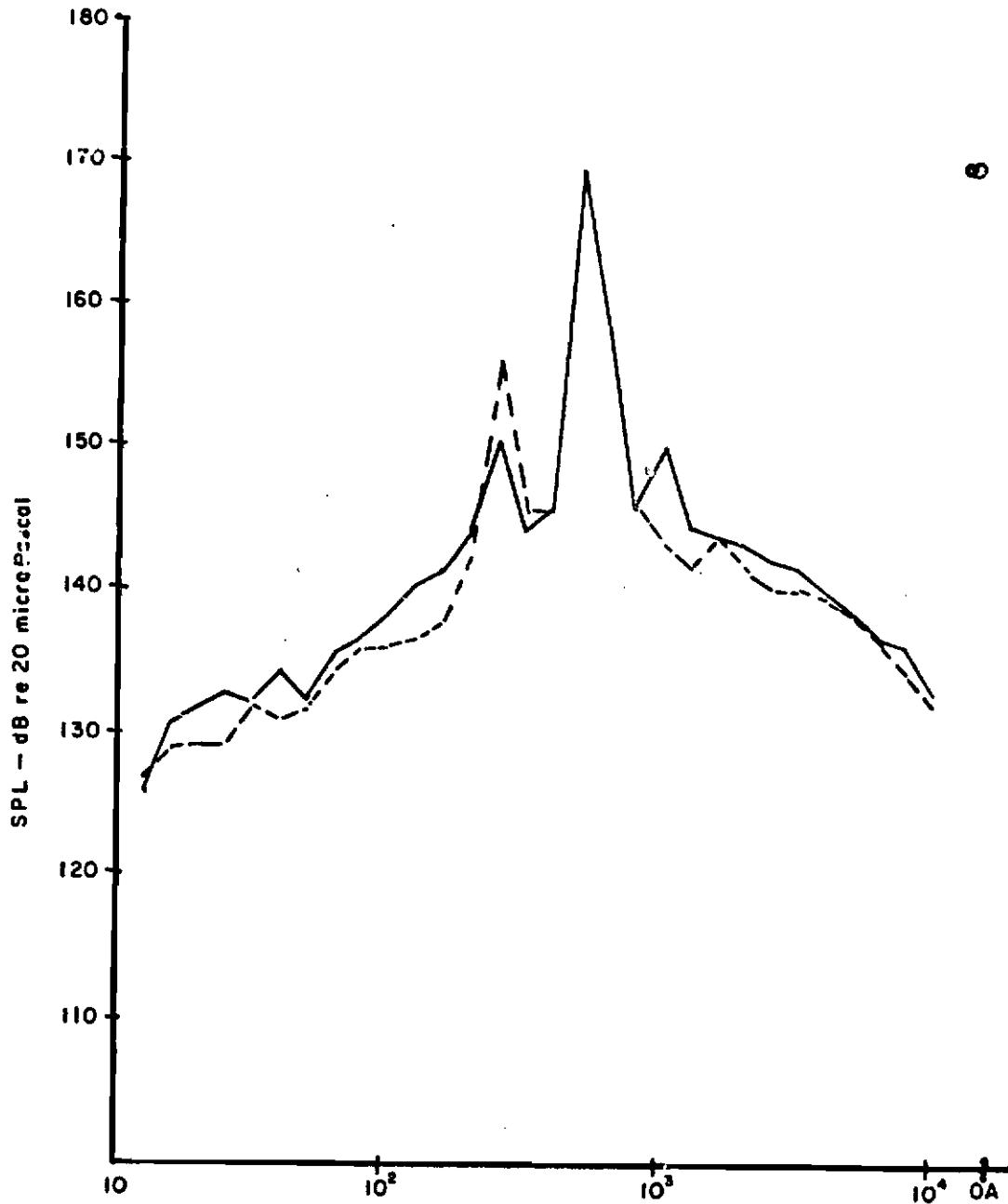

Figure 29. Comparison of the Spectra from the Single Cavity with (-----) and without (——) Doors for Mach Number 1.2 and 30,000-Foot Altitude

AFFDL TR-79-3119

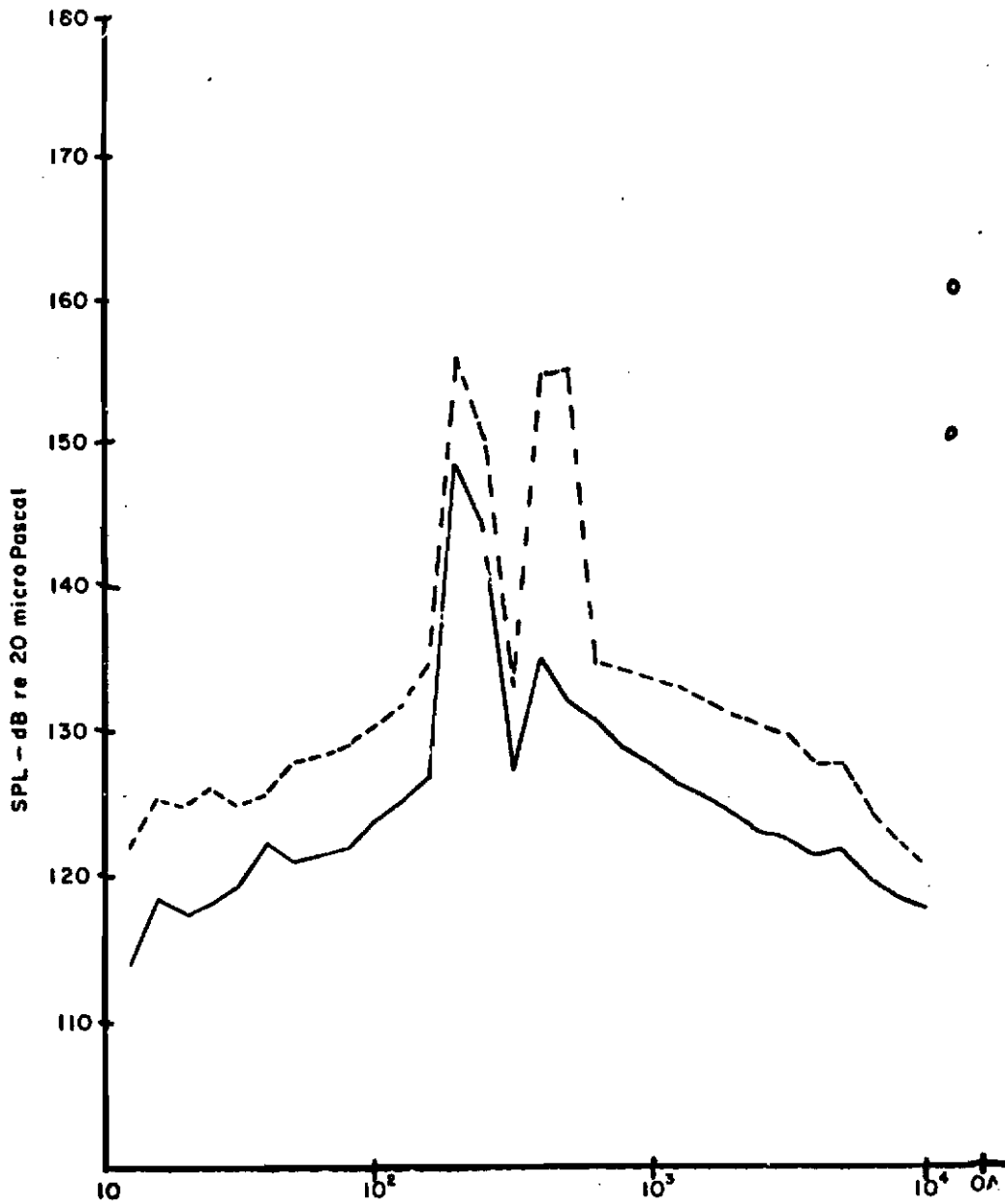

Figure 30. Comparison of the Spectra from the Single Cavity with Doors with (—) and without (-----) a Ramp for Mach Number 0.8 and 30,000-Foot Altitude

AFFDL-TR-79-3119

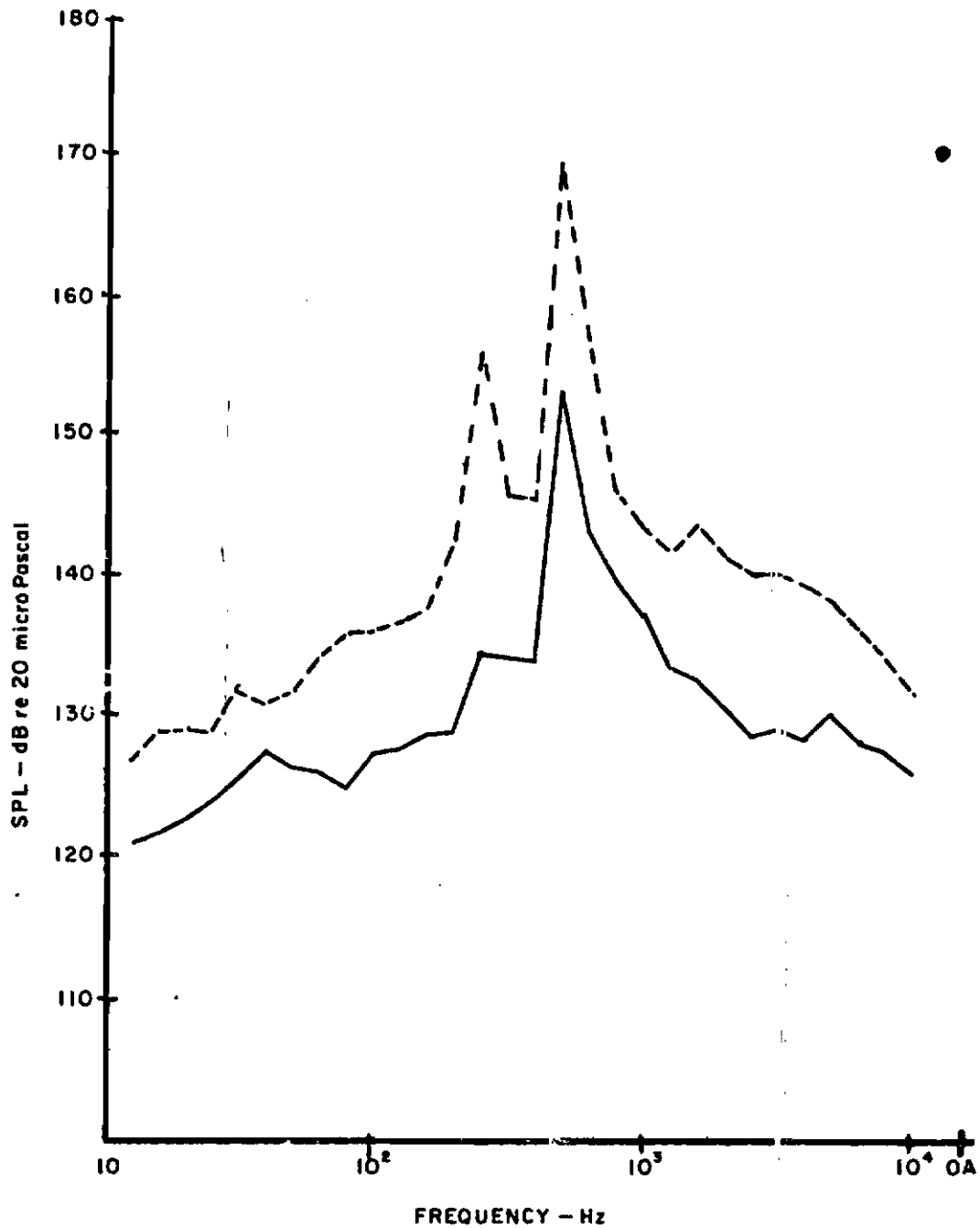

Figure 31. Comparison of the Spectra from the Single Cavity with Doors with (—) and without (----) a Ramp for Mach Number 1.2 and 30,000-Foot Altitude

AFFDL-TR-79-3119

viewed, the total energy in the cavity is lowered because the overall level is reduced by 10 dB. Significantly different results occurred at the supersonic Mach number of 1.2 (Figure 31). The first modal frequency amplitude was suppressed instead of the second, and the broadband levels were lowered approximately 8 dB. The reason for the switch in suppressed frequencies is not sufficiently understood to give a plausible explanation. The overall level was reduced 16 dB.

The trailing edge ramp is seen to be effective in suppressing one or the other frequencies. However, if spoilers are added at the leading edge of the cavity, both frequencies can be suppressed as seen in Figures 32 and 33. At Mach number 0.8 (Figure 32) the ramp and spoiler are seen to effectively suppress both the first and second modal frequency amplitudes. The levels are lowered by 20 dB which brings them down to the broadband levels. The broadband levels are only lowered by 1-2 dB. The overall level is reduced 16 dB. Somewhat better results are obtained at the supersonic speed as seen in Figure 33. Both frequencies are suppressed, and the broadband levels are lowered 4-5 dB. The overall level is reduced 20 dB.

The next configuration considered is the ramp with an airfoil (see Figures 3 and 4). The 1/3 octave band spectra for Mach number 0.8 are shown in Figure 34. It is revealed that the first modal frequency is completely eliminated, and the second frequency is reduced 5 dB, but the broadband levels were increased 2-3 dB. The overall level is lowered 8 dB. The supersonic spectra in Figure 35 revealed an interesting occurrence. The first modal frequency is eliminated as at the subsonic speed, and the second frequency is lowered about 4 dB but is shifted to a higher frequency. The explanation for this shift is a change in the effective length of the cavity. The airfoil is mounted ahead of the aft bulkhead. The perturbances in the shear layer interact with the airfoil and thus the effective length of the cavity opening is from the forward bulkhead to the airfoil instead of from the forward bulkhead to the rear bulkhead.

AFFDL-TR-79-3119

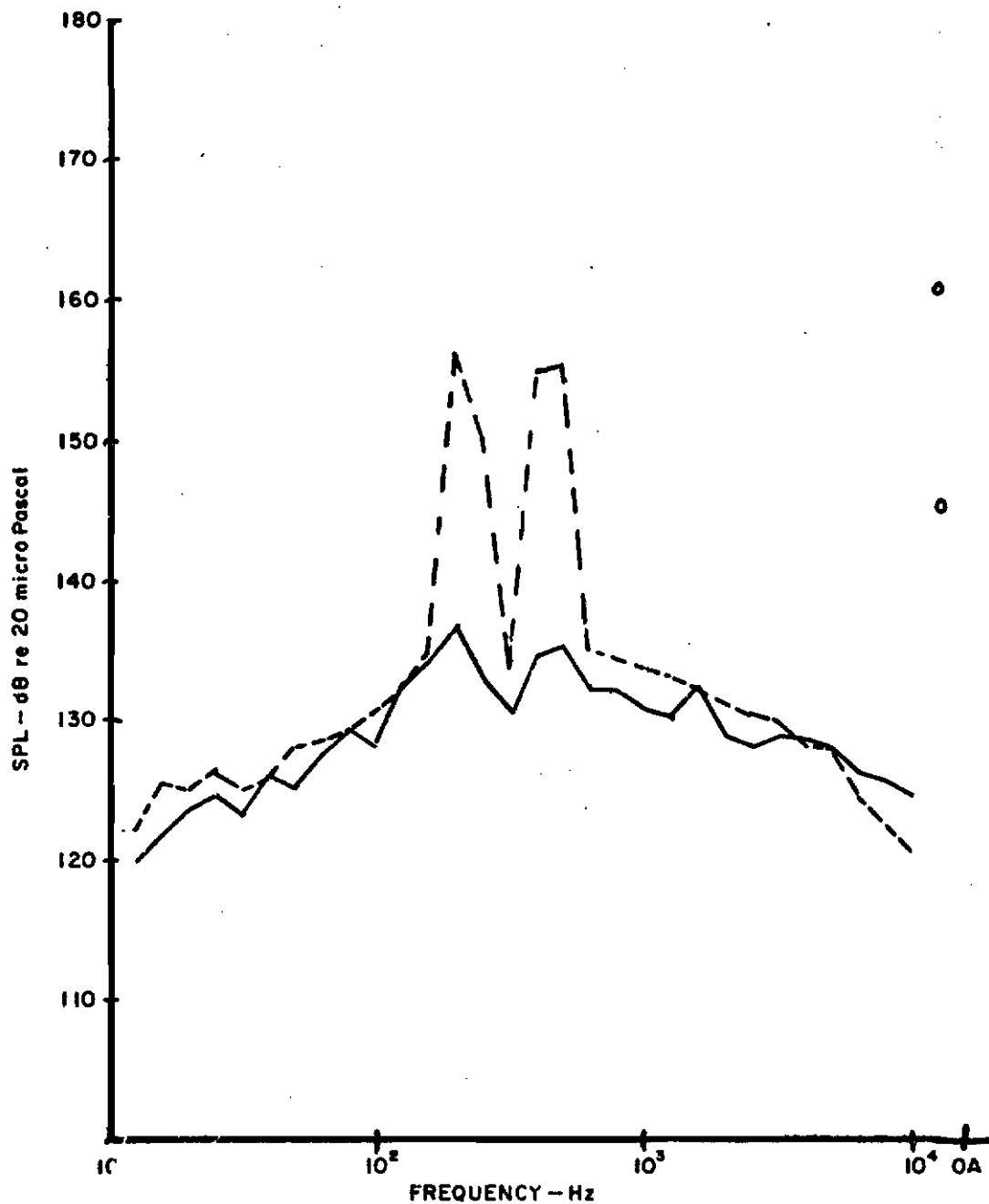

Figure 32. Comparison of the Spectra from the Single Cavity with Doors Configuration with (—) and without (-----) a Ramp and Spoiler for Mach Number 0.8 and 30,000-Foot Altitude

AFFDL-TR-79-3119

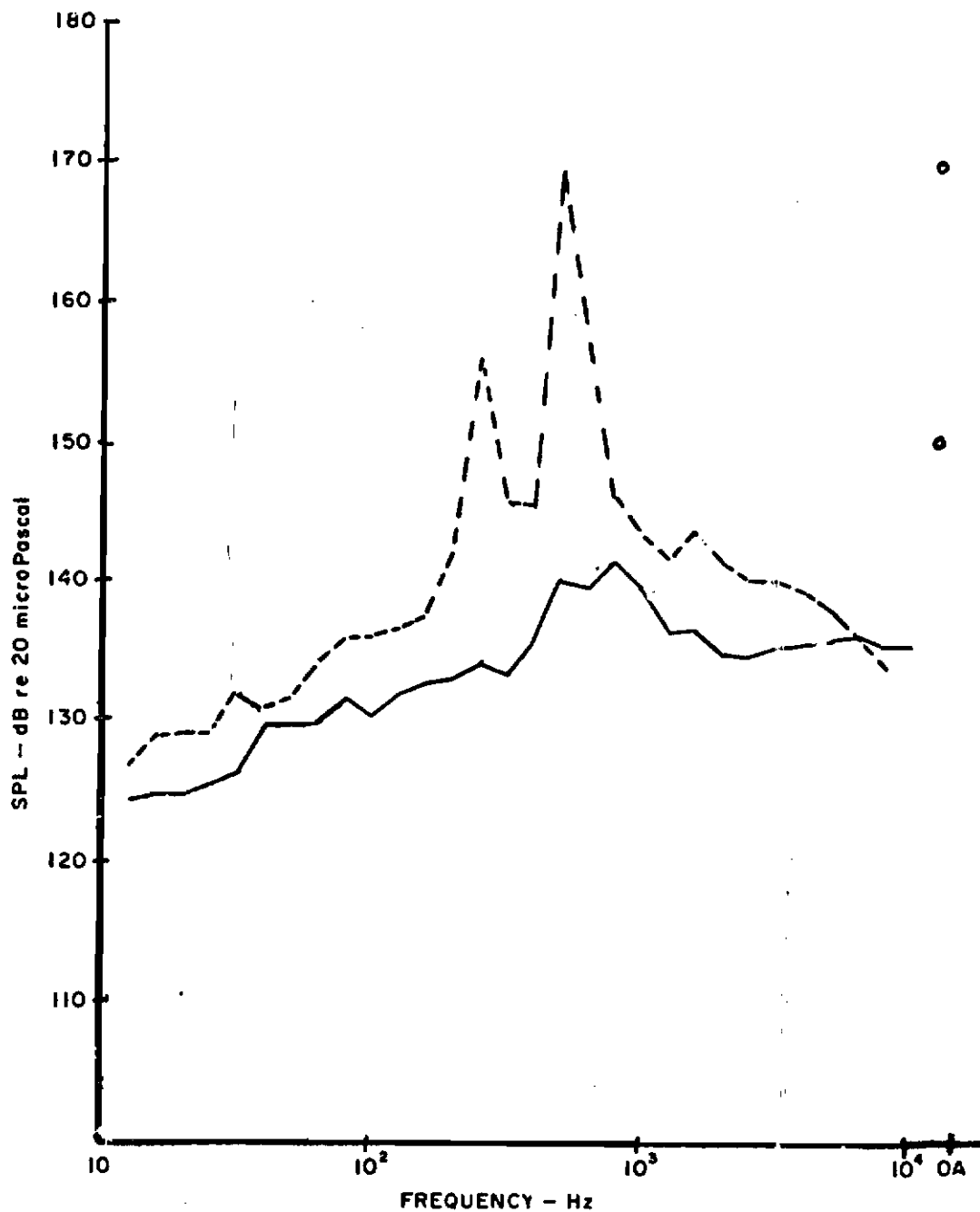

Figure 33. Comparison of the Spectra from the Single Cavity with Doors Configuration with (—) and without (----) a Ramp and Spoiler for Mach Number 1.2 and 30,000-Foot Altitude

AFFDL-TR-79-3119

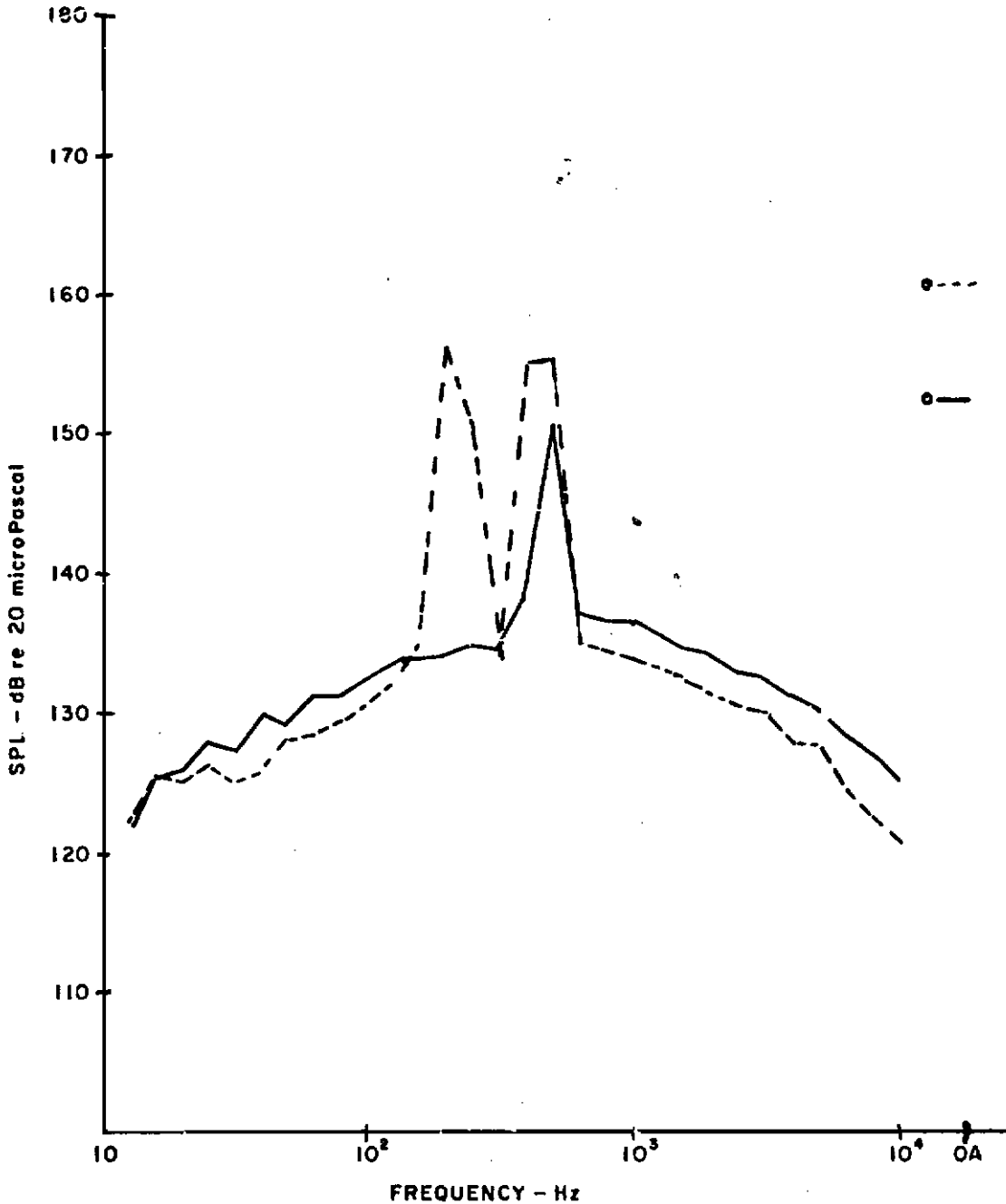

Figure 34. Comparison of the Spectra from the Single Cavity with Doors Configuration with (——) and without (-----) a Ramp and Airfoil for Mach Number 0.8 and 30,000-Foot Altitude

AFFDL-TR-79-3119

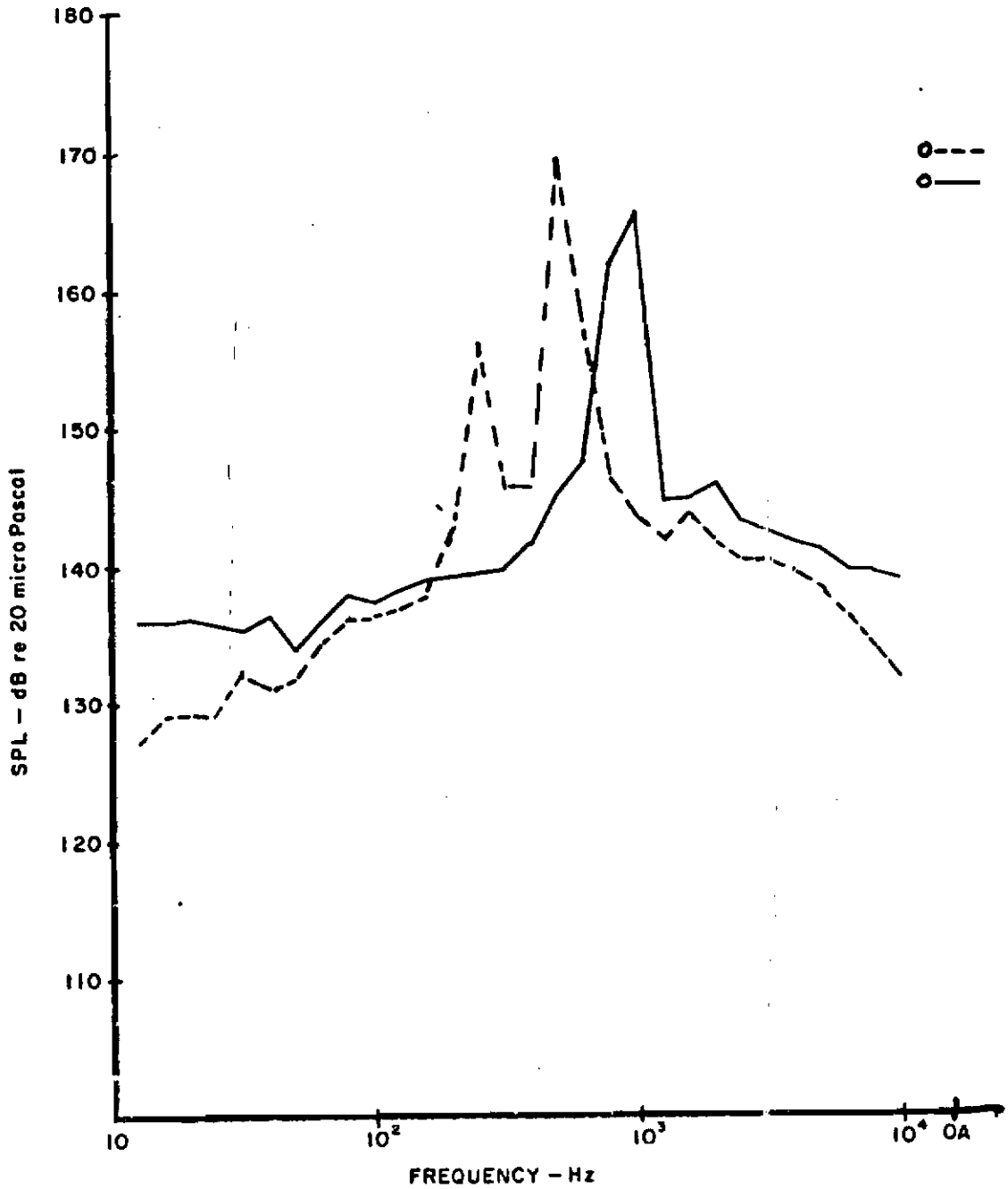

Figure 35. Comparison of the Spectra from the Single Cavity with Doors Configuration with (—) and without (----) a Ramp and Airfoil for Mach Number 1.2 and 30,000-Foot Altitude

AFFDL-TR-79-3119

The magnitude of the shift corresponds with that predicted by the Modified Rossiter equation:

$$f = (V/L)(m-0.25)/[M/(1+0.2M^2)^{1/2} + 1.75]$$

where

V = freestream velocity

L = cavity length

M = freestream Mach number

m = modal frequency number (1, 2, 3, etc)

The overall level is only reduced about 2 dB.

Figures 36 through 39 illustrate the effectiveness of the ramp for the double-cavity configuration. The spectra from the single cavity with doors and ramp, and front cavity with doors and ramp, for Mach number 0.8 are shown in Figure 36. The variation is seen to be on the order of 1-2 dB at most frequencies. The overall levels are within 1 dB. The results from the rear cavity with a ramp are compared to the single cavity with doors and ramp in Figure 37. The levels are again only affected a small amount at limited frequency bands. The modal frequency amplitudes are essentially the same as well as the overall levels. The spectra for supersonic Mach number 1.2 from the front cavity are seen in Figure 38. It is revealed that the ramp is not as effective in the front cavity at this speed. The second modal frequency amplitude is 4 dB higher, and the first is almost 8 dB. The overall level is 4 dB higher than the single-cavity configuration. The supersonic rear cavity results are shown in Figure 39. The ramp is even less effective in the rear cavity. Both modal frequency amplitudes are increased 7 dB, and the broadband levels are increased 5-7 dB. The overall level is increased 7 dB. Thus, the aft bulkhead ramp is essentially as effective for both double cavities as the single-cavity configuration at subsonic speeds but somewhat less effective at supersonic speeds.

Due to anomalies in the data acquisition system, fluctuating pressure data were not obtained from the last two double-cavity configurations (Figure 3).

AFFDL-TR-79-3119

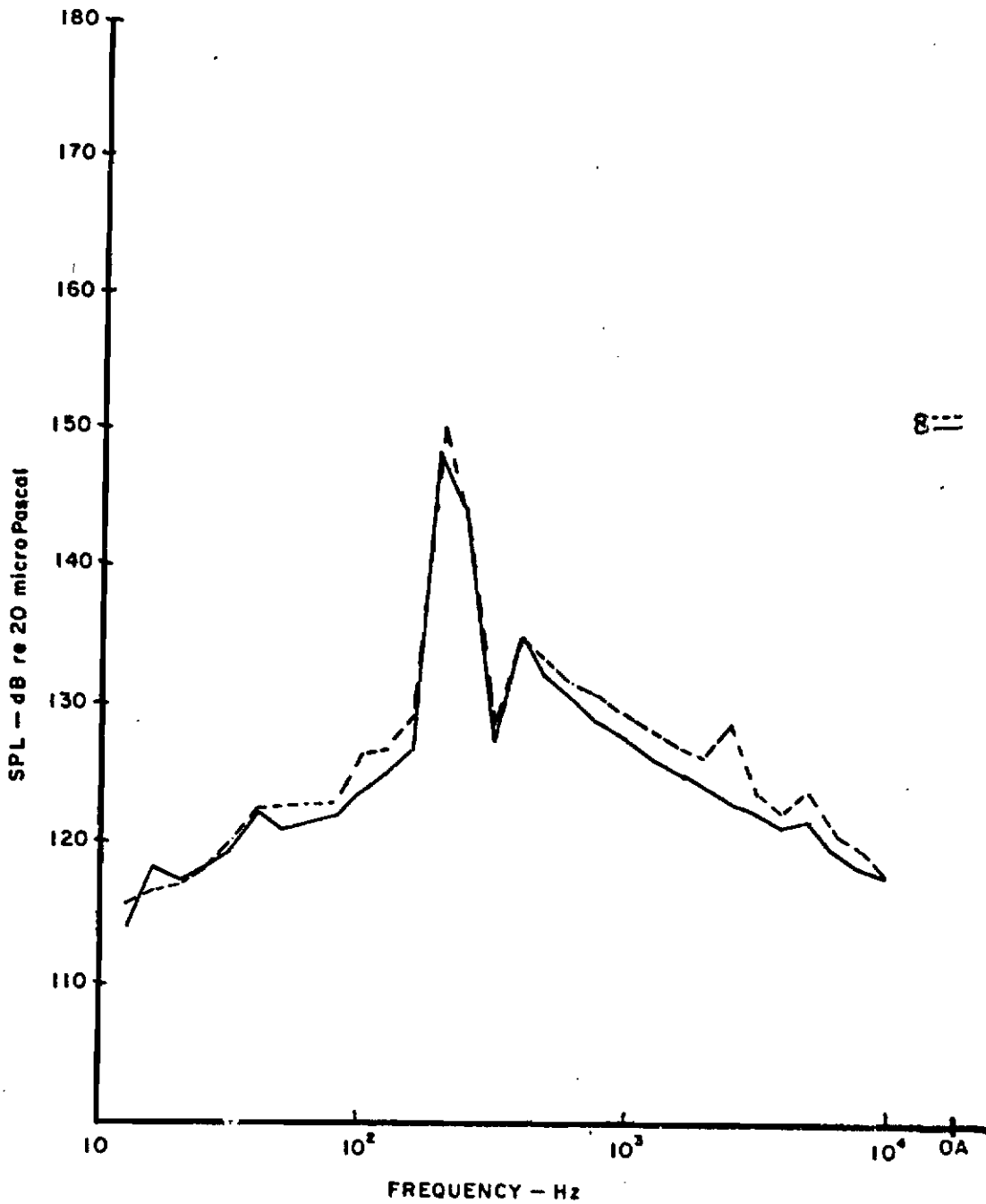

Figure 36. Comparison of the Spectra from the Single Cavity with Doors and Ramp (—) and the Front Cavity with Doors and Ramp (----) for Mach Number 0.8 and 30,000-Foot Altitude

AFFDL-TR-79-3119

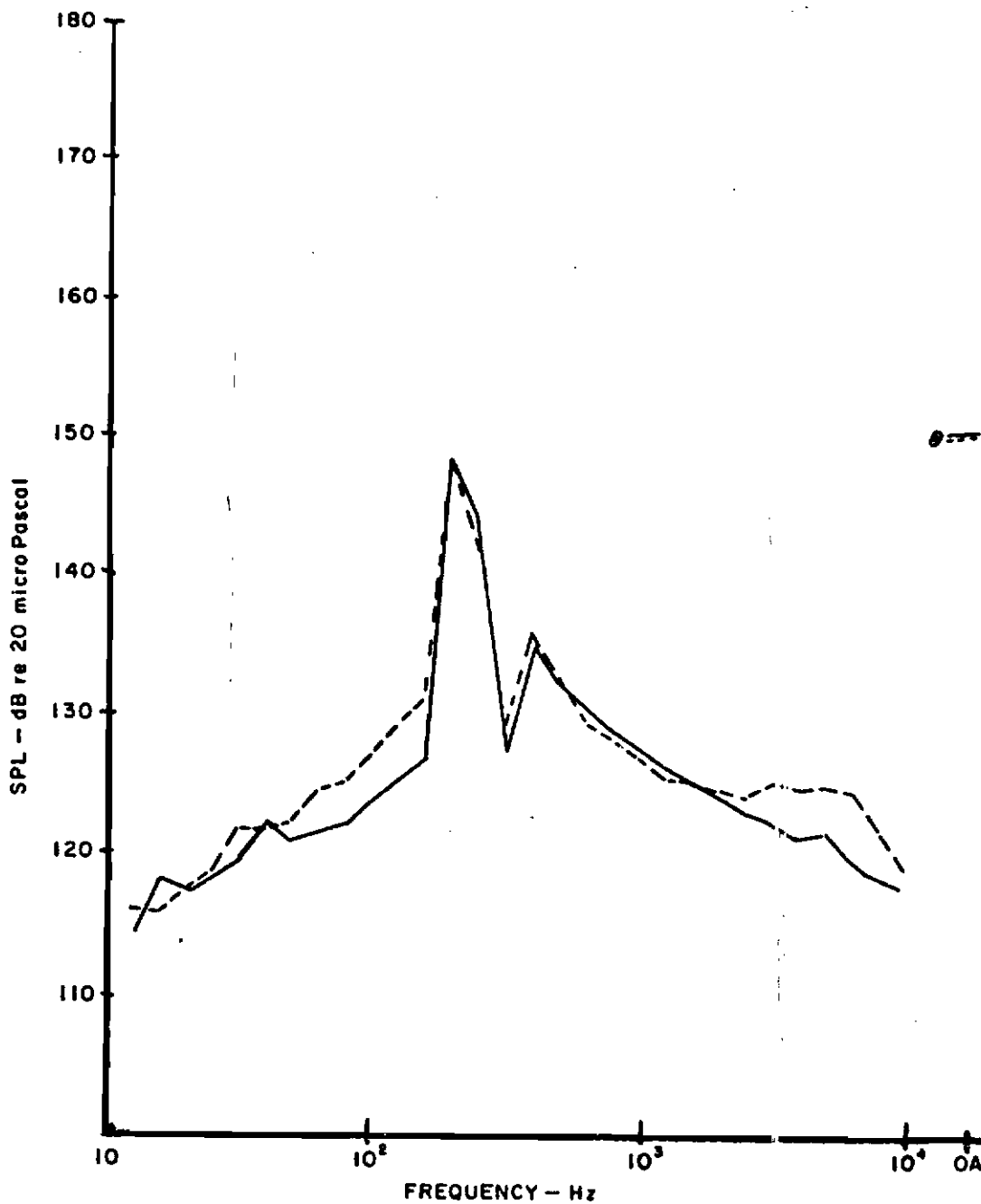

Figure 37. Comparison of the Spectra from the Single Cavity with Doors (—) and the Rear Cavity with Doors and Ramp (----) for Mach Number 0.8 and 30,000-Foot Altitude

AFFDL-TR-79-3119

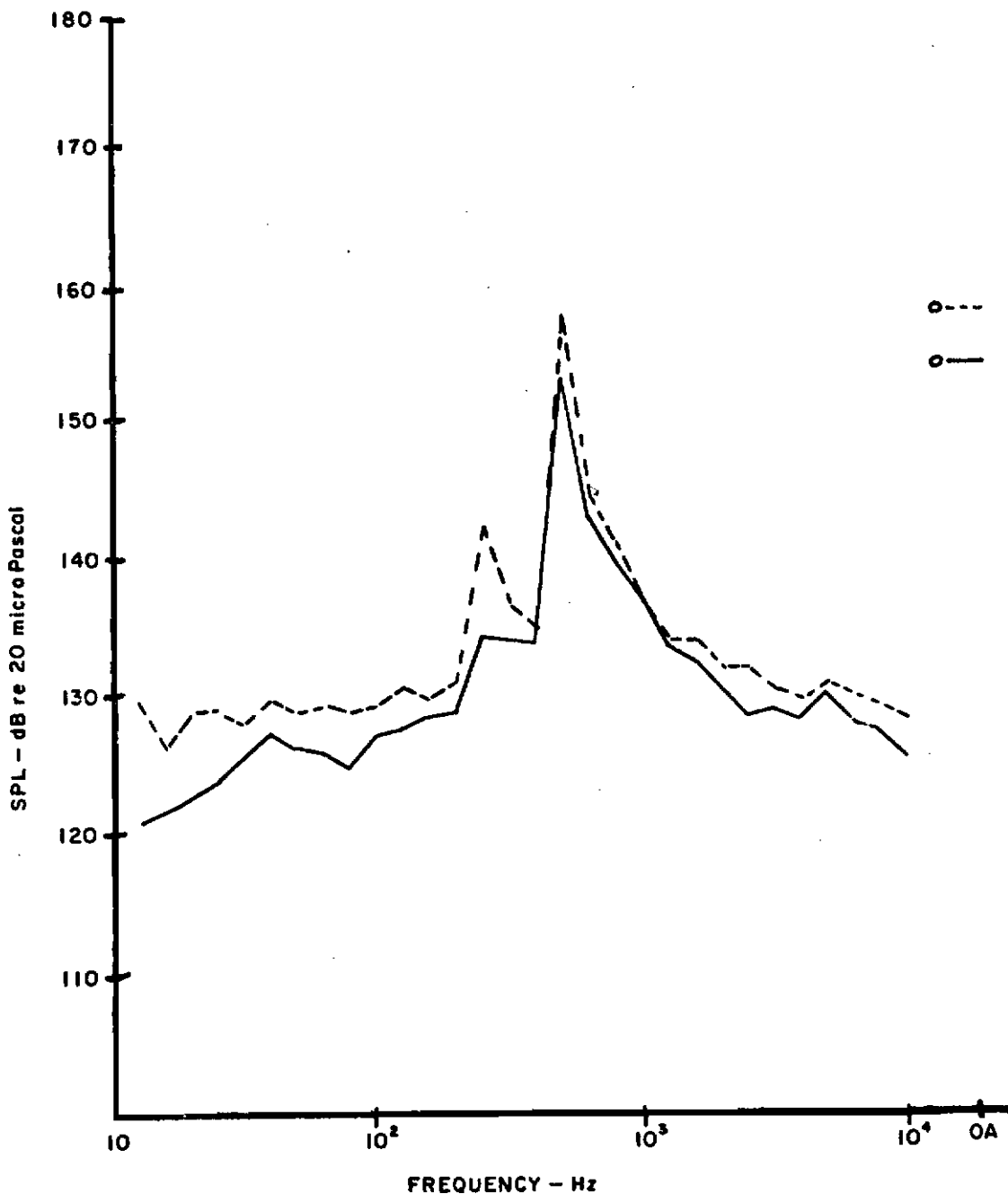

Figure 38. Comparison of the Spectra from the Single Cavity with Doors and Ramp (—) and the Front Cavity with Doors and Ramp (----) for Mach Number 1.2 and 30,000-Foot Altitude

AFFDL-TR-79-3119

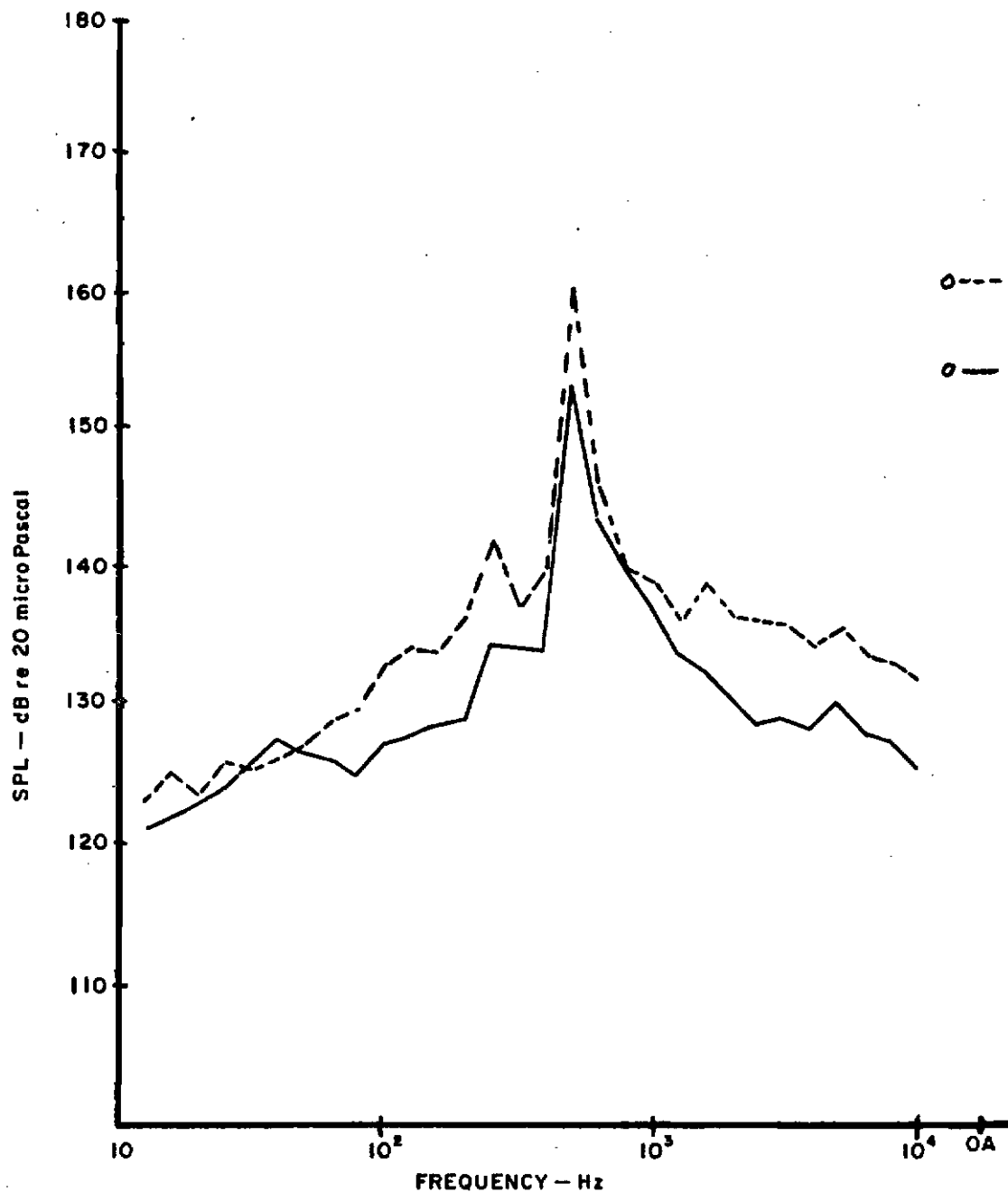

Figure 39. Comparison of the Spectra from the Single Cavity with Doors and Ramp (—) and the Rear Cavity with Doors and Ramp (----) for Mach Number 1.2 and 30,000-Foot Altitude

AFFDL-TR-79-3119

SECTION IV
CONCLUSIONS

A flight test was performed to evaluate the effectiveness of devices in suppressing the flow-induced pressure oscillations in cavities with a length-to-depth ratio of 2. The devices were leading edge spoilers, trailing edge ramp, and an airfoil located at the trailing edge. A basic unsuppressed cavity was tested, and the results compared well with other data in the literature. Another configuration with simulated doors was tested. It showed that the doors had a negligible effect on the fluctuating pressure levels in the cavities. The simulated doors were installed for all of the remaining tests. The trailing edge ramp was shown to effectively suppress one of the modal frequencies but not the other. By adding the leading edge spoilers in conjunction with the ramp, both modal frequencies were suppressed. This configuration was the most effective suppressor. The airfoil and ramp configuration only suppressed the first modal frequency effectively. A double-cavity configuration with both trailing edges ramped was tested. At subsonic speeds both cavities displayed nearly the same levels as the single cavity with a ramp. However, at supersonic speeds both cavities showed 4-7 dB less suppression than the single cavity with a ramp. Based on the above results, the following conclusions are shown:

1. The flow-induced cavity pressure oscillations for this cavity configuration ($L/D=2$) can be effectively suppressed by utilizing a trailing edge ramp in conjunction with leading edge spoilers.
2. The suppression was effective at both subsonic and supersonic speeds.
3. The effectiveness of the ramp suppressor for the double-cavity configuration is nearly equal to that of the single cavity for subsonic speeds, but significantly reduced for supersonic speeds.
4. The suppression devices raised the temperature in the cavity for all cases.

The suppression devices, for most cases, lowered the static pressure in the cavity.

REFERENCES

1. Carr, D. L., "An Experimental Investigation of Open Cavity Pressure Oscillations," M. S. Thesis, Air Force Institute of Technology, Wright-Patterson AFB, Ohio, 1974.
2. East, L. F., "Aerodynamical Induced Resonance in Rectangular Cavities," Journal of Vibration and Sound, May 1966.
3. Heller, H. H. & Bliss, D. B., "Aerodynamically Induced Pressure Oscillations in Cavities - Physical Mechanisms & Suppression Concepts," AFFDL-TR-74-133, August 1974.
4. Heller, H. H., Holmes, G. Covert, E. E., "Flow-Induced Pressure Oscillations in Shallow Cavities," AFFDL-TR-70-104, Dec 1970.
5. Krishnamurty, K., "Acoustic Radiation from Two-Dimensional Rectangular Cutouts in Aerodynamic Surfaces," NACA Tech Note 3487, August 1955.
6. Lawson, M. V., "Prediction of Boundary Layer Pressure Fluctuations," AFFDL-TR-67-167, April 1968.
7. Muall, D. J. and East, L. F., "Three-Dimensional Flow in Cavities," Journal of Fluid Mech 16, p 620, 1963.
8. Maurer, O., "Investigation and Reduction of Open Weapon Bay Pressure Oscillations in the B-1 Aircraft," AFFDL-TM-74-101-FYA, January 1974.
9. Plumbee, H. D., Gibson, J. S., and Lassiter, L. W., "A Theoretical and Experimental Investigation of the Acoustic Response of Cavities in Aerodynamic Flow," WADD-TR-61-75, 1962.
10. Roshko, A., "Some Measurements of Flow in a Rectangular Cutout," NACA Tech Note 3488, 1955.
11. Rossiter, J. F., "Wind Tunnel Experiments on the Flow Over Rectangular Cavities at Subsonic and Transonic Speeds," RAE Rep Nr 64027, R&M Nr 3438, 1966.
12. Shaw, L. L., et al, "Aero-Acoustic Environment of a Rectangular Cavity with a Length to Depth Ratio of Four," AFFDL-TM-74-19-FYA January 1974.
13. Shaw, L. L., and Smith, D. L., "Aero-Acoustic Environment of Rectangular Cavities with Length to Depth Ratios in the Range of Four to Seven," 45th Shock and Vibration Bulletin, June 1975.
14. Smith, D. L. et al, "Aero Acoustic Environment of Rectangular Cavities with Length to Depth Ratios of Five to Seven," AFFDL-TR-79-FYA, April 1974.
15. Smith, D. L., and Shaw, L. L., "Prediction of the Pressure Oscillations in Cavities Exposed to Aerodynamic Flow," AFFDL-TR-75-34, April 1975.