

Continued

WADC TECHNICAL REPORT 55-223

AIR-TO-AIR TRACKING WITH LINEAR AND NON-LINEAR YAW DAMPING

Gifford Bull and Edwin A. Kidd
CORNELL AERONAUTICAL LABORATORY, INC.

JUNE 1955

Aeronautical Research Laboratory
Contract No. AF 33(038)-12753
Task No. 70513
Project No. 1364

Wright Air Development Center
Air Research and Development Command
United States Air Force
Wright-Patterson Air Force Base, Ohio

~~_____~~

FOREWORD

This report covers work done by the Flight Research Department, Cornell Aeronautical Laboratory, Buffalo, New York, on Air Force Contract No. AF33(038)-12753, Project No. 1364, Task No. 70513, entitled, "Research in Non-Linear Mechanics". The work was administered under the direction of the Aeronautical Research Laboratory, Wright Air Development Center, with Mr. P. P. Cerussi acting as project engineer.

The work was started by Mr. I. C. Statler, of the Cornell Aeronautical Laboratory, who also performed the theoretical calculations upon which the design of the servo and computer were based. Design and development of the servo and computer system were the responsibility of the Instrumentation Section, Flight Research Department, Cornell Aeronautical Laboratory. Particular credit is due Mr. J. L. Beilman, who acted as Instrumentation Engineer throughout the project.

This document, excepting the title, is classified CONFIDENTIAL in its entirety because of the nature of, and potential military application of, the research work and data described herein.

ABSTRACT

Air-to-air tracking tests were made with a jet fighter airplane in which the damping of the Dutch roll could be varied in flight. Damping of the Dutch roll could be made a linear or non-linear function of the sideslip angle. Quantitative results are presented in terms of variations in tracking aim error with Dutch roll damping. The effects of non-linear damping are shown. Pilot opinion data is included.

PUBLICATION REVIEW

This report has been reviewed and is approved.

FOR THE COMMANDER:

Aldro Lingard

ALDRO LINGARD, Colonel, USAF
Chief, Aeronautical Research Laboratory
Directorate of Research

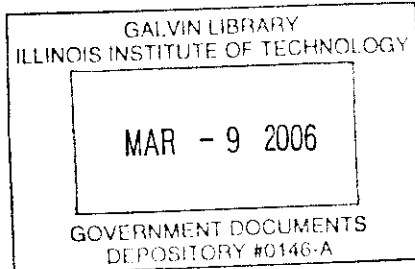

TABLE OF CONTENTS

	Page
LIST OF ILLUSTRATIONS	v
LIST OF TABLES	vi
INTRODUCTION	1
DESIGN OF YAW DAMPER SYSTEM	4
PERFORMANCE OF YAW DAMPER	10
RECORDING SYSTEM	12
CONDUCT OF THE TESTS	14
TREATMENT OF THE DATA	20
DISCUSSION OF TEST TECHNIQUES IN THE LIGHT OF THE ANALYZED DATA	27
CONCLUSIONS	32
REFERENCES	33
APPENDIX - THEORETICAL ANALYSIS	34
FIGURES	39
TABLES	64

LIST OF ILLUSTRATIONS

Figure	Title	Page
1	Schematic Drawing of Rudder Servo Installation	39
2	Block Diagram of Non-Linear Yaw Damper System	40
3	Manner In Which The Yaw Damping Was Varied To Make It Non-Linear	41
4	Variation of Rate Gyro Sensitivity With Dynamic Pressure .	42
5	Variation of Rate Gyro Sensitivity With Mach Number	43
6	Frequency Response of Yaw Damper Servo System	44
7	Flight Records Showing Effect of Linear Yaw Damper	45
8	Flight Records Comparing Effect of Linear and Non-Linear Yaw Damper Operation	46
9	Tracking Camera Installation	47
10	Sample Tracking Camera Picture	48
11	Comparison of Sideslip Calculated from Lateral Accelera- tion With Sideslip Measured By Vane	49
12	Demonstration of Statistical Normality of Tracking Data . . .	50
13	Aim Error vs. Number of Tracking Runs. Pilot A	51
14	Aim Error vs. Number of Tracking Runs. Pilot B	52
15	Aim Error vs. Number of Tracking Runs. Pilot C	53
16	Aim Error vs. Range. Pilot A	54
17	Aim Error vs. Range. Pilot B	55
18	Aim Error vs. Range. Pilot C	56
19	Aim Error In Straight Stern Chase	57
20	Mean Aim Error vs. Range. Pilot A	58
21	Mean Aim Error vs. Range. Pilot B	59
22	Mean Aim Error vs. Range. Pilot C	60
23	Pitch Aim Error vs. Range. Pilot A	61
24	Pitch Aim Error vs. Range. Pilot B	62
25	Pitch Aim Error vs. Range. Pilot C	63

LIST OF TABLES

Table		Page
I	Summary of Experience of Pilots	64
II	Data Summary, Tracking Errors. Pilot A	65
III	Data Summary, Tracking Errors. Pilot B	66
IV	Data Summary, Tracking Errors. Pilot C	67
V	Pilot Comments. Pilot A	68
VI	Pilot Comments. Pilot B	70
VII	Pilot Comments. Pilot C	72
A-I	Equations of Motion	74
A-II	List of Symbols	75

INTRODUCTION

Combat gun camera film taken in air-to-air gunnery action shows a marked yawing oscillation of the airplane as the pilot attempts to track the target. Such an oscillation increases the difficulty of the pilot's job of tracking the target, and decreases the chances of hitting the target when the guns are fired. This oscillation, known as the Dutch roll, is a familiar characteristic of airplanes, and is accentuated by the design features characteristic of modern high speed airplanes.

The lateral dynamics of an airplane can be improved by moving the control surfaces, through servos, in a fashion such as to damp the unwanted Dutch roll motion of the airplane. One method of increasing the damping of the Dutch roll is to move the rudder proportional to yaw rate. This is the method employed in a conventional yaw damper.

Making the rudder motion correspond to a function of yaw rate which varies with sideslip offers some advantages over a linear proportionality between rudder motion and yaw rate. Investigation of the merits of such a device is the purpose of the work reported here.

ADVANTAGE OF A NON-LINEAR YAW DAMPER

In a linear system a fundamental conflict in requirements exists. If the damping is made high, the airplane does not oscillate after a disturbance, but it is sluggish in returning to the original undisturbed position. On the other hand, light damping allows the airplane to return rapidly to neutral from a disturbance but allows the airplane to oscillate around neutral in the familiar Dutch roll.

Pilots presumably like an airplane to return promptly to neutral after a disturbance, without any oscillation. This type of motion cannot be obtained by a linear yaw damper system whereby the damping of the motion is increased and not the frequency. It can be obtained by a non-linear system in which the rudder motion tending to damp the airplane motion is made small while the

airplane is away from the neutral position after a disturbance, but becomes large when the airplane approaches the neutral position. The airplane, therefore, returns rapidly toward neutral, due to the light damping away from neutral, but does not overshoot because the damping becomes heavy around neutral.

Linear systems are usually employed where possible because not only are such control systems simpler, but also the mathematical methods used in analyzing and predicting their behavior are very much simpler than for non-linear systems. However, the calculations of the properties of a non-linear system has become practical with the availability of modern computational equipment. The application of a non-linear device should be considered, despite equipment and mathematical complications, if it can be shown that the non-linear device will provide the desired response characteristics where a linear device will not.

EXPERIENCE WITH F4U - EXTENSION OF F4U TESTS TO F-86

Flight tests of a non-linear yaw damper installed in an F4U-5 airplane were conducted by Cornell Aeronautical Laboratory for the Aeronautical Research Laboratory of Wright Air Development Center. These tests are described in Reference 1.

The consensus of the pilots who participated in those tests was that the airplane could be made into a better gun platform with the non-linear yaw damper than with the linear yaw damper, and that each of them was better than the normal airplane with no yaw damper.

The non-linear yaw damper, then, appeared to offer a means for improving the lateral dynamics of an airplane beyond what was practical by aerodynamic means alone (normal airplane) or by a linear yaw damper.

The Aeronautical Research Laboratory, Wright Air Development Center, contracted with Cornell Aeronautical Laboratory to extend the tests to an airplane representative of current design trends, and an F-86E was chosen as a suitable test airplane. In addition, it was planned to modify the system used to produce the non-linear damping in order to eliminate some undesirable aspects of the system which were observed during the tests reported in Refer-

ence 1.

The tests were to be arranged to provide a quantitative measure of the tracking ability of the airplane with various amounts of linear and non-linear damping, as well as pilot opinions on the suitability of the airplane as a gun platform for the various damping configurations.

DESIGN OF YAW DAMPER SYSTEM

Requirements of Yaw Damper System

Experience gained in conducting the tests of the non-linear yaw damper installed in the F4U airplane dictated several of the basic requirements for the design of a similar system for the F-86 airplane. The F4U tests had shown that pilots liked a relatively high damping of the lateral-directional oscillation of the airplane and in fact liked the motion to be deadbeat, provided the airplane still responded promptly to rudder pedal forces applied by the pilot. The particular form of yaw damper installed in the test F4U utilized an auxiliary rudder to provide the variable damping. Aerodynamic interference between the auxiliary and main rudders produced peculiar rudder pedal force feel characteristics. These force characteristics were somewhat distracting and annoying to the pilots, and it was considered worthwhile going to considerable effort, if necessary, to produce a system which did not alter significantly the normal airplane's control force feel.

Analog computations (see Appendix) indicated that the yawing moment due to aileron deflection would become objectionable under some circumstances, and some scheme for correcting for this yawing moment was to be incorporated in the design of the non-linear yaw damper system.

To summarize, the requirements for the non-linear yaw damper were as follows:

1. The type of non-linearity used in the experiments with the F4U (Reference 1) was satisfactory, and could be carried over to the newer airplane.
2. Sufficient damping must be provided to make the Dutch roll oscillation deadbeat over the operating speed and altitude range of the airplane.
3. Operation of the yaw damper must not spoil other aspects of the handling qualities of the airplane.
4. The control forces must be natural, and as close to the feel of the

- normal airplane as possible.
5. Means must be provided to counteract the yawing moment due to aileron deflection.
 6. The pilot must be able to trim the rudder if the system does not allow use of the normal ship's rudder trim.
 7. It must be possible to vary the damper setting in flight to allow convenient comparison, during a given flight, of the behavior of the airplane with linear and non-linear damping of various amounts.
 8. The equipment must be simple to operate, to allow the pilot to concentrate on tracking the target with a minimum of attention to the yaw damper system.
 9. The system should be designed to "fail safe".

Description of Yaw Damper

SERVO

The yaw damper system divides naturally into two parts, the sensing and computing part and the servo and rudder feel part, which will be described first.

TRIM TAB SYSTEM

With the above requirements in mind, a system was evolved in which the yaw damper servo was made to drive the rudder tab, which in turn drove the rudder to produce the required damping of the Dutch roll. The pilot's rudder pedals were to remain connected to the rudder, allowing him to superimpose his command rudder motion upon the rudder motion called for by the yaw damper. When the yaw damper moved the rudder, the pilot would be able to feel the motion in his pedals. This characteristic was considered acceptable since the amount of rudder motion required was expected to be small, and since pilots usually are not as concerned with control motion as they are with control force.

The servo actuator was to be installed inside the rudder in the space

normally occupied by the ship's rudder trim tab actuator. A system of this nature was designed, built, and installed. It was able to produce practically deadbeat damping of the Dutch roll. However, the additional weight of the servo, the larger trim tab which was required and the associated mass balances increased the mass and moment of inertia of the rudder to the point where vibration troubles were encountered. During the shakedown flight tests, the rudder broke off in flight. The failure was not due to the operation of the yaw damper or the servo, since the system was turned off and the airplane was being flown by manual control at the time. The trouble occurred because the installation of the servo inside the rudder changed the dynamic characteristics of the rudder for the worse.

RUDDER SYSTEM

The yaw damper system was redesigned to use the standard F-86 rudder, without alterations. The yaw damper servo was arranged to drive the rudder directly. The rudder was then operated by an irreversible power control and some form of artificial rudder feel was necessary. Rudder feel was provided by a spring, and the sensitivity of the rudder to rudder pedal force was made inversely proportional to dynamic pressure to simulate the normal airplane. When the yaw damper was disengaged, the rudder was connected directly to the rudder pedals, and the rudder control system was essentially in its normal configuration. The schematic diagram of Figure 1 shows the way in which the yaw damper servo was connected to the rudder, and the engaging mechanism. The development of the servo is described in Reference 2.

A pair of quadrants were inserted in the rudder cable system. The servo and rudder were connected to one of the quadrants. The rudder pedals were connected to the other. A hydraulic actuator (the "shifting actuator") operated a splined shaft to connect the two quadrants together, or disconnect them as required. Figure 1a shows the rudder control system connected for manual operation of the rudder. The shifting actuator was spring loaded to hold the spline shaft in a position which connected the two quadrants together. The pilot then had a solid connection from the pedal to the rudder. The servo had its by-pass valve open to allow oil to circulate freely from one side of

the piston to the other as the quadrant, and hence the servo piston, was moved by the pilot. The rudder pedal forces felt by the pilot consisted of the normal rudder pedal forces plus the friction in the quadrant bearings and servo packings, forces due to the inertia of the quadrant and servo piston, and the force required to circulate the oil from one side of the servo piston to the other. These forces were all small compared to the normal rudder forces, and the pilots considered that, as far as they could tell, they were operating a normal airplane.

Figure 1b shows the system connected to operate the rudder by the servo. Hydraulic pressure was supplied to the shifting actuator, overcoming the spring holding it in the "manual operation" position, and moving the splined shaft to the "servo operation" position. In this position, the two quadrants were disconnected from each other. The quadrant with the servo fastened to it remained connected to the rudder. At the same time, the servo by-pass valve was closed, allowing the servo to control the rudder. The quadrant connected to the rudder pedals was engaged by the splined shaft to a spring which provided the rudder pedal force feel. An electrical pickup was also connected to this quadrant to produce an electrical signal proportional to displacement of the rudder force spring. The excitation of this electrical pickup was made inversely proportional to dynamic pressure, making the output of the pickup proportional to:

$$\frac{\text{rudder pedal force}}{\text{dynamic pressure}}$$

This electrical signal was used to drive the rudder servo, so the rudder displacement was also proportional to this quantity. This behavior approximated the behavior of the normal airplane rudder in which the rudder displacement is also proportional to pedal force/dynamic pressure. The difference was that the pedals moved just as far for a given pedal force at high airspeeds as at low, whereas the pedal travel for a given pedal force in the normal airplane decreases as the speed, and hence the dynamic pressure, increases. It was felt that this system produced a satisfactory simulation of the force feel characteristics of the normal airplane because it was believed that pilots flew more by control forces than control positions, and the pedal

travel was small on the F-86 airplane under any circumstances. The pilots felt that the rudder feel was very nearly the same whether flown by manual or servo control.

When the airplane was flown manually, all hydraulic pressure to the servo systems was shut off. The actuator which moved the splined shaft and operated the servo by-pass valve was spring loaded in the manual operation position. Hydraulic pressure was required to shift from manual to servo operation. Loss of hydraulic pressure would, therefore, result in the system returning automatically to the manual operation configuration. Furthermore, the servo was designed to be unable to exert a force on the rudder greater than that corresponding to 300 lb of rudder pedal force.

In view of the loss of the rudder while flying with the trim tab actuated system installed, a fairly complete vibration survey was made of the redesigned system to make sure that the installation was safe. The vibration tests were made in consultation with the Aeromechanics Department, Cornell Aeronautical Laboratory, and the Dynamics Branch, Aircraft Laboratory, Wright Air Development Center. The results of the vibration tests, which indicated that the rudder and servo installations should be free from flutter troubles, were reported in Reference 3. The shakedown flights were arranged to allow increases in dynamic pressure and Mach number to be made in small increments, with inspection of flight oscillograph records between increments. No vibration troubles or servo instability problems were encountered in flight over the range of flight conditions covered, which included Mach numbers to .95 and altitudes from 5,000 to 32,000 feet.

SENSING AND COMPUTING ELEMENTS

Selection of the sensing elements to supply the signals for the yaw damper and design of the computing circuits was determined by the results of the analog computations described in the Appendix. The primary sensing element was a Doelcam Model K rate gyro, arranged to sense yaw rate.

A block diagram of the yaw damper system is shown in Figure 2.

The yaw rate signal was made non-linear by multiplying it by a function of lateral acceleration and dynamic pressure (approximately sideslip). The

function is shown graphically in Figure 3. The signal was further modified by functions of Mach number and dynamic pressure to produce a net signal which would move the rudder to produce constant damping of the Dutch roll regardless of altitude and speed. These functions were determined by the effect of dynamic pressure on the motion of the airplane and by the effect of Mach number on the stability derivatives and are shown in Figures 4 and 5. In addition, signals proportional to rudder pedal forces applied by the pilot were included in the net signal to the rudder, to allow the pilot to transmit his command signals to the rudder. The computer included provisions for rejecting the steady state yaw rate signals which would occur in a steady turn so the pilot would not have to produce command signals large enough to overpower the steady state yaw rate signals when he wanted to turn.

The net signal to the servo could be expressed in words as:

Rudder = Sensitivity x [yaw rate] x [non-linearity] x [corrections for Mach number and dynamic pressure] x [filtering to reject signals due to steady state turns] + pilot's rudder pedal forces x [correction for dynamic pressure] + sensitivity of aileron coordination system x [aileron motion.]

In more conventional symbols, this may be expressed as:

$$d_r = K[r][F(n_y/q)][F_1(M) F_2(q)][F_3(t)] + F_p[F_4(q)] + K_A[\dot{\alpha}]$$

The significance of the knobs by which the pilot selected linear or non-linear operation could be altered from flight to flight to minimize the chances of the pilot's opinions being colored by previous experience with a particular knob setting.

PERFORMANCE OF THE YAW DAMPER

Successful operation of the yaw damper demands that the servo be capable of moving the rudder essentially as called for by the yaw damper computer. As discussed in the Appendix, an investigation was made to determine how the dynamic characteristics of the servo affected the motion of the airplane. A servo system which behaved as a second order system with a natural frequency of about 10 cps and 70% critical damping was found to be fast enough for the purpose. The servo dynamics of any servo appreciably slower than this affected the motion of the airplane to an extent which was not acceptable. This was especially true of non-linear operation, where more rapid control surface motions were required.

Figure 6 compares the dynamic performance of the servo controlled rudder with the requirements just set forth. The frequency response of the servo controlled rudder, including the effects of air loading, was synthesized from measured servo characteristics, calculated control cable spring and rudder inertia characteristics, and calculated air load effects. The amplitude ratio of the servo system drops off a little more rapidly than that for the second-order system, but the phase lag behaves approximately as required. The servo system, as installed, was a fifth-order system, and caution must be used in applying familiar second-order system criteria in discussing the behavior of the servo.

The pilots reported that the servo-controlled rudder system felt very similar to the normal rudder control, implying that the servo performance was good enough to move the rudder in response to rudder pedal forces applied by the pilot in all the maneuvers tried, including small corrections in tracking where the servo performance might be expected to be most critical.

The ability of the yaw damper to increase the damping of the Dutch roll is shown in Figures 7 and 8. The motion could be made practically deadbeat, or 100% critically damped. The tap switches in the cockpit enabled the pilot to select the damping in increments of 30%, 70% and 100% critical damping



as well as normal airplane (approximately 10% critical damping at 25,000 feet and 0.7 Mach number). The difference between linear and non-linear operation of the yaw damper is easily seen in Figure 8. The pilot was able to select the amount of non-linearity, but in practice the runs were made with either a linear system or one with the degree of non-linearity shown in Figure 8 and as specifically defined in Figure 3.



RECORDING SYSTEM

Three distinct classes of data were to be recorded to provide the data used in evaluating the non-linear yaw damper. These were:

1. Aim error, recorded by a gun camera viewing both the target and the gunsight reticle.
2. Airplane motion, recorded on an oscillograph.
3. Pilot's comments, transmitted by radio to the ground and recorded on a wire recorder.

GUN CAMERA

A standard GSAP camera was arranged to provide a picture of both the reticle and the target. At the time the installation was made, there was no standard method for accomplishing this, and the installation, shown in Figure 9, was devised especially for this airplane. Figure 10 shows a typical picture made with this installation. The film magazines could be changed in flight. The pilot operated the camera by the trigger switch on the control stick.

OSCILLOGRAPH

An oscillograph and its associated sensing elements and circuitry were installed to obtain time histories of both airplane and control surface motions. Although not directly essential to the evaluation of the non-linear yaw damper, the oscillograph was installed for two reasons:

1. Oscillographic records of the behavior of the servo system were expected to be invaluable for trouble shooting and setting sensitivities during the development of the system.
2. Although, a considerable amount of gun camera film was available from various sources, there was a dearth of information on the motion of the airplane and the controls during the tracking maneuver. This project presented an opportunity to secure such data at a relatively

small expense, as a by-product of the flight tests which were necessary to the project.

The installation of the oscillograph, a Consolidated Model 5-118, and its related recording circuits was essentially straightforward. The quantities recorded were:

- roll angle
- roll rate
- rudder pedal force
- rudder position
- servo strut position
- lateral acceleration
- yaw rate gyro excitation
- yaw rate multiplied by gyro excitation
- dynamic pressure
- time
- voltage of a circuit which determined some of the recording sensing element sensitivities
- gun camera shutter operation

PILOT'S COMMENTS

The pilot's comments on the behavior of the airplane and its suitability as a gun platform were considered an essential part of the data obtained in the flight tests. The pilot transmitted his comments to the ground by radio, where they were recorded by a wire recorder. The comments were later transcribed verbatim, and kept as a permanent record. Comments were made during and immediately after each test run, while the impressions were still vivid.

CONDUCT OF FLIGHT TESTS

The flight tests divided naturally into three groups:

1. Shakedown flights, to demonstrate the structural integrity of the modifications made to the airplane's rudder controls, and to develop the yaw damper system to the point where it operated reliably and with the proper sensitivities.
2. Evaluation flights by CAL pilots, to develop the technique to be used by the Air Force pilots in their evaluation flights. The data reduction methods to be used were developed at this time.
3. Evaluation flights by Air Force pilots.

Sixty-four flights, totaling 55 hours, were made in the course of the program. Ten of these flights were evaluation flights by Air Force pilots, eight were evaluation flights by C. A. L. pilots, and the rest were shakedown flights largely devoted to proving the structural integrity of the modifications to the rudder control system. Twelve of the shakedown flights were made with the trim-tab-controlled rudder which was developed early in the program and then abandoned.

SHAKEDOWN FLIGHTS

The shakedown flights involving the trim-tab-controlled yaw damper will not be commented on here, since that system was abandoned after rudder vibration was encountered.

Several flights were made in which both sideslip and lateral acceleration were measured, to determine whether lateral acceleration could be used in lieu of sideslip to control the non-linearity of the yaw damper. If these two quantities were substantially equivalent, external booms carrying sideslip vanes would not be required. Figure 11 is a plot of the results of one of these flights and indicates that sideslip calculated from measured values of lateral acceleration and dynamic pressure agreed quite well with measured sideslip. The agreement was improved somewhat by including the effect of

lateral acceleration due to rudder deflection in the calculated expression, but the uncorrected values are shown in Figure 12 because it was planned to supply the yaw damper computer with the uncorrected values.

Shakedown flights on the system in which the yaw damper controlled the rudder directly were made to demonstrate that the modified rudder control system was free from vibration and that the complete yaw damper and servo system had no instability troubles. Increases in Mach number and dynamic pressure were made in small increments, and the flight records of the behavior of the airplane and the control system were studied carefully between flights. The yaw damper was operated only at flight conditions which had been investigated with the servo (but not the yaw damper) on, and the servo was operated only at flight conditions which had been checked previously under manual control. The pilot was provided with a rudder vibration warning meter which was operated by an angular accelerometer on the rudder. The meter was designed to provide the pilot with a warning of vibration amplitudes too small for him to feel in the airplane. In addition, the oscillograph recorded the output of a vibration pickup installed in the top of the fin.

The airplane and the yaw damper installation were shown to be safe over the anticipated operating range of Mach number and altitude, namely 5,000 - 32,000 feet and .3-.95 Mach number.

The sensitivity of the yaw damper was set to give about 100% critical damping of the Dutch roll at the maximum damper gain setting available to the pilot. The response to rudder kicks with various yaw damper settings is shown in Figures 7 and 8. Records similar to these were obtained at various dynamic pressures and Mach numbers. The damping of the Dutch roll was found to be constant for a given setting of the pilot's damping gain control, regardless of dynamic pressure and Mach number, indicating that the yaw damper computer was correcting properly for these two variables.

It will be recalled that the non-linear feature of this yaw damper was applied by making the yaw damper sensitivity become smaller as the sideslip angle increased. However, the yaw damper sensitivity was left high for a small sideslip angle range around zero. The shape of the curve of variations of yaw damper sensitivity with sideslip is shown in Figure 3. The width of the

~~Confidential~~

plateau at the top of the curve determined how great the sideslip angle had to be before the yaw damper sensitivity started decreasing. The width of the plateau could be varied in flight from infinitely wide (no variation in yaw damper sensitivity, i. e., a linear yaw damper) to some value, determined experimentally, which provided optimum response of the airplane. In practice it was found that the variations in sideslip produced by the pilots in the tracking maneuver and in normal flight were so small that the yaw damper never became non-linear unless the plateau width was made very small, approximately 0.5 deg.

The measured Dutch roll response of the airplane, shown in Figures 7 and 8, was obtained with the plateau width, or degree of non-linearity, which was used in the evaluation tests. At this setting, the yaw damper operation became non-linear at irregular intervals during most of the tracking runs whenever the pilot exceeded 0.5 deg. sideslip.

The feature of the servo system which moved the rudder to correct for yaw due to aileron deflection was experimented with during the shakedown flights. The evidence as to the usefulness of this correction was not conclusive. While a small amount of this correction was tried in the tracking flights made by the C. A. L. pilots, it was not used at all in the evaluation flights made by the Air Force pilots.

EVALUATION FLIGHTS

QUANTITATIVE DATA

One of the requirements of the evaluation flights was that the results should provide some quantitative measure of the tracking performance of the airplane with various settings of the yaw damper to supplement the opinions of the pilots on the subject. The tests were concerned only with air-to-air gunnery. A target airplane was used to provide the test airplane with a realistic moving target. A repeatable maneuver was required to allow comparison of the results of the various runs.

The maneuver chosen was considered representative of a typical gunnery situation and was essentially the same maneuver used by the USAF and the

~~Confidential~~

NACA in investigations of air-to-air tracking problems. The maneuver started in a stern chase in straight and level flight, with a range of about 2,000 feet. At some time after about fifteen seconds from the commencement of the run, the target airplane started a turn and held the turn for about fifteen to twenty seconds. The target airplane's acceleration was held constant at about $2\frac{1}{2}g$ in the turn. The airspeed was also held constant, which required a slight dive during the turn. A maneuver of this type provides samples of tracking in straight and level flight, steady turns, and during the transient which occurs during the entry and recovery to the turns. There was some element of surprise in the maneuver since the tracking pilot did not know exactly when the target pilot would enter or recover from the turn, nor did he know which direction the target pilot would choose for the turn.

The target airplane used for all of the shakedown and most of the data flights was an F-80C. An F-86A was used for the last three tracking flights, because the F-80C was not available. The tracking runs using the F-80C as a target airplane were done at a Mach number of about .7. When the F-86A was used as a target, the runs were made at a Mach number of .7 to .75, to keep the flight conditions comparable to the tests with the F-80C target.

Most of the tests were conducted at an altitude of 25,000 feet. Some test runs were made at 3,500 feet in rough air, and some were made at 10,000 and 12,000 feet because of weather limitations. The high altitude runs were made in smooth air, while rough air was encountered at the lower altitudes. Occasionally the pilot reported encountering the jet wash of the target airplane or buffeting due to approaching the stall in the turn. Comments of this nature are included in the resumé of the test runs.

Each Air Force pilot made four quantitative data flights. Each flight consisted of ten data runs, and since five configurations were evaluated, this program provided eight runs per pilot for each configuration. The configurations which were flown were:

1. Normal airplane
2. 30% damping of the Dutch roll, linear operation
3. 70% damping of the Dutch roll, linear operation
4. 70% damping of the Dutch roll, non-linear operation

5. 100% damping of the Dutch roll, non-linear operation

The shakedown flights had shown that linear operations with 100% critical damping made the airplane too sluggish in its response to be acceptable, while the difference between linear and non-linear operation at 30% critical damping was not large enough to be perceptible.

The pilots used the center of the target airplane's tail pipe as their aiming point. The gunsight was used in the caged position to avoid complicating the problem at this stage with the gunsight dynamics. The pilots were instructed to keep the gunsight pipper on the target rather than to lead the target as they would have to do in actual gunnery with a fixed sight.

It is difficult, in tests such as these, to avoid having the pilot's opinion of the effectiveness of the device being tested influenced by his knowledge of what the device was supposed to do. To relieve the pilot of the burden of consciously having to ignore this influence, the control panel of the yaw damper was arranged to allow the ground personnel to alter the meaning of the knob settings controlling the non-linearity. The pilot was therefore not troubled by a feeling that could be expressed as:

"I turned the knob up one more notch, so the effect must be stronger. I can't see any difference but there must be some, so I'll rate it like the last one but more so."

Instead, the pilot rated each configuration as it appeared to him without being affected by the knob settings.

The pilots were aware of the fact that the meaning of the knob settings could and would be varied from flight to flight.

At one knob setting, not "zero", the complete servo system was disengaged and the pilot was flying the normal airplane through his normal rudder pedal system, although the control panel pilot lights and the position of the switches indicated that the airplane was being flown through the servo. Thus the normal airplane was evaluated in three ways:

1. With the pilot flying it manually and aware that he was flying the normal airplane
2. With the pilot flying it manually but believing he was flying it by the servo
3. With the pilot flying it by the servo but with the yaw damper not opera-

tive, i. e. , simulated normal airplane.

This chicanery was designed to detect whether the pilots had any bias either for or against flying the airplane through the servo because such a bias would affect the rating of the damped airplane compared to the normal airplane. The pilots were not informed of the significance of that particular knob setting until after the flight program was completed.

QUALITATIVE DATA

In addition to the tracking flights, each pilot made a flight devoted to obtaining a qualitative assessment of the handling qualities of the test airplane with various yaw damper settings. The pilot's flight cards contained a number of questions designed to help him form his opinions of the airplane. The object of this flight was twofold: first, to ascertain whether operation of the yaw damper had altered some of the airplane's handling qualities for better or worse in maneuvers other than tracking, and second, to obtain the pilot's opinions of the suitability of the airplane as a gun platform, to compare with the numerical results of the tracking flights. In addition, during the tracking runs the pilots commented on the tracking performance of the airplane as it appeared to them at the time. Pilot's comments were transmitted to the C. A. L. ground radio station where they were recorded.

PILOTS

The pilots who flew the test airplane were experienced fighter pilots with considerable gunnery experience, in both practice and combat. Table I summarizes the experience of the pilots. Pilot A, the C. A. L. pilot, flew the airplane during the C. A. L. evaluation flights and some of the shakedown flights. Another C. A. L. pilot made most of the shakedown flights but did not participate in the evaluation flying.



TREATMENT OF THE DATA

The gun camera film was read to determine the aim errors in pitch and in yaw. Mean and root mean square values of the aim error were determined for each run. The root mean square values are the values about the mean. The root mean square of the aim error was assumed to be a significant measure of the ability of the pilot to hold the airplane on the target.

The gun camera ran at a speed of 16 frames per second, while the Dutch roll of the airplane has a period of 1.5 to 2 seconds. Data was thus taken 32 times per cycle of the motion. The motion could be described adequately with fewer points per cycle. Therefore, every fourth frame was read.

The film was read on a reading device equipped to record the data directly on IBM punch cards. The wing span of the target airplane was read at the beginning and end of each run to provide a stadiometrically determined value of range.

The data was processed on an IBM machine to compute mean and root mean square values of the pitch and yaw aim errors for the straight and level and turning portions of each run. The results are tabulated in Tables II, III, and IV.

DISTRIBUTION OF AIM ERRORS

Fourteen runs from two flights by pilot A were analyzed to determine whether the aim error during each run showed a normal distribution. These runs covered all the values of damping which were investigated and included linear and non-linear operation of the yaw damper. The data from only the turning portion of the tracking maneuver was included in these plots. The turning portion included the transient which occurs on entering the turn. The data from the straight flight portion of the maneuver will be discussed later.

The time histories of these runs were obtained from the IBM data, and the percent of the errors which were less than a certain value of error were tabulated as a function of the error. This information was then plotted on "proba-

bility" paper to determine whether the aim errors had a statistically normal distribution. The scales on probability paper are designed to make data plot in a straight line if the data has a normal distribution. The advantage of using this paper is simply that the familiar bell shaped distribution curve is converted to a straight line which makes it easier to determine the normality of the distribution of the data.

Figure 12 shows the data from Flight 45 by pilot A. Two runs were made at each of five configurations. The two corresponding runs were treated as one set of data for the purpose of this part of the analysis. A similar analysis was made for each individual run of the fourteen runs considered, and the results were similar to those for the runs which were combined. Figure 12 is a working plot, and the abscissa is actually Telereader machine units rather than miles. Furthermore, the mean errors were not removed from the data since the normality of the data could be determined without performing this additional step. Different mean errors for different runs would merely shift the position of the curves. The data plotted as a straight line (Figure 12) indicating a normal distribution of tracking aim errors. The fact that the data showed a normal distribution meant that the rms error was in fact a significant quantity for comparing results from run to run. Had the distribution not been normal, some additional quantities which describe the distribution of the data would be required to properly compare the results from run to run.

The slope of the lines in Figure 12 is inversely proportional to the root mean square of the aim error of the run. It will be seen from Figure 12 that the normal airplane spent more of its time at large aim errors than did the airplane with added damping. However, the data plotted in Figure 12 includes runs at different ranges. Range is later shown to affect the rms of the errors. This makes Figure 12 an unsatisfactory plot with which to compare errors from run to run.

DATA ANALYSIS

The data was plotted in several different ways, to illustrate the effect of several variables in the tracking problem. Figures 13, 14 and 15 show the effect of time, or more properly, learning, on the pilot's ability to track.

The runs made by each pilot were arranged in sequence along the abscissa, with the rms aim error in the turn portion of each individual run plotted vertically above the corresponding run number. No data was available for some runs, such as those for which the camera jammed. Such runs were included in Figures 14, 15 and 16 because they provided experience for the pilots just as much as the runs in which data was obtained. The dates on which the flights were made are shown to illustrate the variation in the test program for the three pilots. Figures 16, 17 and 18 show the rms error for the same runs plotted against range. When the tracking airplane closed on the target airplane during the run, the range used was the average of the range at the beginning and end of the run. Inspection of these six figures indicates that both parameters affect the tracking accuracy. However, the runs made early in each pilot's flight program, which show relatively large aim errors, were often also the runs made at the shorter ranges. It appears that the pilots were learning to estimate the range and to arrange the test maneuver to avoid closing and that this had more effect on their aim errors than did practice in tracking. It will be remembered that all the pilots who participated in the test program were experienced in gunnery maneuvers. Even when allowance is made for the fact that some of the points showing the larger errors in Figure 15 represent runs made at the shorter ranges, it appears that some effect of learning is present. A significant conclusion is that the learning effect is much less pronounced for the airplane with the heavily damped Dutch roll than it is for the more lightly damped airplane. In other words, the pilot could do well with the damped airplane the first time, while he required recent practice to do well with the lightly damped airplane, and, as shown graphically in Figure 15, never did do as well as he could with the more heavily damped airplane.

The effect of range on tracking performance is not unexpected and has been shown before in other studies of tracking, such as Reference 4. A given rate of change of linear position of the target airplane with respect to the sight line of the tracking airplane will produce a more rapid change in the angular error at short range than at long range. The tracking pilot then makes more rapid corrections, which are more likely to result in larger errors. It is also possible that the pilots would accept a certain amount of linear aim error as tolerable.



Again, at short ranges, this would permit larger angular tracking errors. However, when queried on this point, the pilots stated that at short ranges they picked a point on the target airplane to use as a target, and that they were not satisfied to let the pipper move around on the target airplane. Another possible cause for increasing errors at short ranges may be an increase in excitement as the target is neared, leading to overcorrecting and larger errors.

Averaging the rms error for all the runs for a given configuration would weight the short range points unduly and produce a misleading figure for the average. An average figure of a sort, for comparing the effects of various amounts of damping, was obtained by considering only the points occurring at ranges large enough to make the effect of range relatively unimportant. This range was determined by inspection of Figures 16, 17 and 18. It can be seen that the aim error decreased rapidly as the range increased and then started to level off and be relatively unaffected by further increases in range. The "critical" range varied from figure to figure. It is suspected that the variation was not caused by fundamental variations in "critical" range from pilot to pilot, but was due to the relatively small quantity of data and to the fact that the "critical" range was determined by eye in Figures 16, 17 and 18.

The values of the "critical" range which were used are shown on Figures 16, 17 and 18. Although the average values of the rms aim error varied from pilot to pilot, the effect of altering the damping of the Dutch roll was similar for each of them. Damping the Dutch roll cut the values of the rms aim error to about two-thirds that of the normal airplane, but the difference in aim error between the various amounts of damping was too small to have statistical significance. Whether the damping was linear or non-linear also appeared to make no significant difference in the rms aim error. At shorter ranges, the large aim errors for pilots B and C (Figures 17 and 18) tend to occur with the normal airplane or with 30% critical damping of the Dutch roll, while heavier damping, even at the same range, seems to produce smaller aim errors. This was not true for pilot A, where the larger aim errors associated with short ranges were about the same regardless of the damping, or whether the damping was linear or non-linear.

It will be remembered that the above discussion applied to data taken from

the time the target airplane started its turn until it rolled out of the turn or until the run was broken off, whichever occurred first. The aim error data for the straight and level stern chase part of the maneuver was not included because, as shown in Figure 19, there was no discernible effect of either range or damping on the aim errors. Most of the points for Figure 19 show a very small aim error (about one mil) and it is suspected that errors this small may represent the errors due to resolution of the pilot and gunsight.

Mean aim error vs range is shown in Figures 20, 21 and 22. Neither range nor damping had much effect on the mean errors, except that pilot B showed somewhat higher mean errors for the normal airplane than for the airplane with added damping. It is not surprising that the mean aim error does not depend on the damping of the Dutch roll; if the nose is moving back and forth across the target, the pilot would tend to keep the average, or mean, of the oscillation on the target, and wait for the motion to damp out. The yaw damper simply makes the motion damp out sooner. The mean errors were generally small except that pilot B, Figure 21, showed a number of runs with quite appreciable mean errors (3 to 6 mils).

PITCH AIM ERRORS

Projection of the tracking films showed quite a noticeable pitch oscillation, with a frequency very nearly that of the yawing oscillation. Normally, of course, the pitching motion is considered independent of the lateral and directional motion for small disturbances such as occur in the tracking maneuver. It was suspected, however, that suppression of the lateral-directional, or Dutch roll, oscillation might lead to smaller pitch aim errors, due either to a coupling of the two modes of motion or to coupling through the pilot. The latter coupling could conceivably have occurred because suppression of the Dutch roll would leave the pilot free to apply more effort to the pitching motion. (Pilot A commented that he felt that this appeared to be the case). Presumably the pitching oscillation would show up more if the yawing oscillation were not present and this might make the pilot put more effort into damping the pitch oscillation than he would when the pitch oscillation was masked by the yawing oscillation.

Rms pitch aim error for the turn maneuver is shown in Figures 23, 24 and 25. Damping the lateral motion had no effect on the pitch aim errors. This result is consistent with the usual separation of the lateral and longitudinal modes of motion, but is rather surprising in view of the pilots' comments. No further investigation of this point was made, since it did not seem to be relevant to the problem in hand.

PILOT OPINIONS

Tables V, VI, and VII summarize the opinions of the pilots concerning the suitability of the airplane for tracking. The comments were made in flight, during or immediately after each run. All of the available pilot comments are included in the tables. The comments were occasionally summarized, but the pilot's wording was retained.

There were occasional inconsistencies in the pilot's remarks. For example, a given amount of damping of the Dutch roll might be rated good on one try and mediocre on another. The inconsistencies were the exception rather than the rule. Pilot comments on roughness of the air and whether they hit the target airplane's jet wash are noted directly on Figures 14, 15 and 16.

The most noticeable characteristic of the pilot comments is the discrimination between runs with various amounts of added damping. The difference between 30%, 70% and 100% critical damping of the Dutch roll was apparently quite clear to the pilots although the quantitative aim errors of Figures 16, 17 and 18 do not show a very marked difference. The comments would lead one to expect more difference between the normal airplane and the damped airplane than shows in Figures 16, 17 and 18.

When fuel was available after the tracking runs were completed, the pilots were asked to make whatever maneuvers they pleased which would help them to notice whether there was any difference between the settings for linear and non-linear operation at 70% critical damping. The pilots did not know which of the two settings was linear and which was non-linear, but they did know that the damping was the same for the two settings. The comments concerning these comparisons are included in Tables V, VI and VII. In general, the pilots could not see much difference in the behavior of the airplane between linear and non-

linear operation, but, given the choice, they would usually pick the non-linear operation. The oscillograph records showed that the sideslip angles encountered in tracking were small and that the system frequently was not called upon to become non-linear in the runs when it was set for non-linear operation. The runs in which this was noticed to be the case are marked in the tables. Furthermore, runs for which oscillograph records were not available to determine whether the yaw damper became non-linear are also marked. The serious effect of the small aim errors on the difference between linear and non-linear operation of the yaw damper is discussed later, and must be kept in mind when considering the pilot's comments on the subject.

It will be remembered that each pilot made one flight in which no target airplane was used, to allow him to make a qualitative assessment of the effect of the various amounts of damping of the Dutch roll on the utility of the airplane as a fighter. The comments made on these flights are identified as such in the tables. They agreed with the comments made during the tracking flights.

DISCUSSION OF TEST TECHNIQUES, IN THE LIGHT OF THE ANALYZED DATA

In designing a test to measure some aspects of the tracking performance of a combat airplane, several courses are open to the experimenter. One course is to determine all of the relevant factors in the problem, make tests under the particular conditions which best bring out the effect of each factor, then synthesize the results into a complete picture of the tracking maneuver. Such a test technique presupposes knowledge of what the factors affecting the problem are, and of the way in which they are interrelated. At the other extreme, the tests may be made in actual combat. Such a statement may sound ill considered, but reflection will show that a good deal of experimentation goes on in combat conditions. New devices or techniques are concocted and the promising ones are given a try. Since the object of combat is to win, clearly only the optimum thing is tried. One would not knowingly try good, bad and indifferent variations merely to see what effect the variations had on the outcome of the combat. Even so, the effect of variations in technique and equipment can be determined as new and better variations supplant the old ones. Furthermore, even in combat a good deal of information is gathered which is most valuable, although gathering the information is not done to directly affect the outcome of the particular combat action. An example is combat gun camera film, which is useful in the problem under examination here.

The limitations of experimentation in combat, including the very fortunate one that combat conditions are not usually available, lead to tests done in simulated combat. Again, a choice in the philosophy of the tests is open to the experimenter. The tests can be designed to simulate combat as closely as possible, with careful separation of the variables in the test made subordinate to the requirements of realism. When this is done, statistical techniques may be used to separate the effect of the variables. Statistical techniques imply quantities of data, which usually require extensive tests to secure.

On the other hand, the experimenter can endeavor to sort out which

variables he can manipulate without prejudice to the realism of the tests and organize his tests to show the effect of these variables, leaving an unknown number of variables to be taken care of by simulating as closely as possible the actual operating conditions, i. e., combat. Tests of this type involving limited simulation of the actual operating conditions are widely used in engineering. It is usually possible to control the major variables and still provide sufficiently good simulation to take care of numerous other variables which might be hard to account for otherwise. This reduces the number of runs required compared to a purely statistical analysis of an experiment with full simulation.

A test technique of the limited simulation type was selected for the tests described in this report. Other investigations of various aspects of the tracking problem have also used this technique. In this case, a tracking maneuver which combat operations had shown to be useful and typical was formalized to make the maneuver repeatable, thus eliminating variations in the tracking maneuver from the problem. Some simulation of combat was retained in that the tracking pilot did not know precisely when or in what direction the target pilot would make his turn. Most of the runs were made in smooth air, to eliminate the effect of variations in air turbulence from run to run. Some runs were purposely made in rough air to see how much air turbulence affected the tracking performance of the airplane and pilot. The range was supposed to be held constant at a value typical of successful combat operations, and variations in range were taken into account in presenting the data. The order in which the various damping configurations were presented to the pilot for evaluation was made non-systematic in a given flight and was varied from flight to flight. The effects of learning were considered in analyzing the data. In short, an effort was made to allow explicitly for every way in which the tests were modified from an actual combat operation. Two known factors were not allowed for. One was the excitement and surprise of combat; the other was the knowledge on the part of the pilot that in combat he is a target as well as a tracker. It is undoubtedly true that pilots can concentrate on tracking much more effectively in practice and test runs than they can in combat.

In spite of the care which was taken in the design and conduct of the tests,

Confidential
[Redacted]

it seems clear that there is something wrong, and this is true of all the tracking tests which have come to the attention of the authors. First, the aim errors which were found in the tests were too small, compared to aim errors measured from combat gun camera film. Second, the numerical results which purport to show the effect of the damping of the Dutch roll on the tracking performance do not agree well with the opinion of the pilots on the subject.

The rms aim errors were of the order of 2 to 6 mils with occasional runs with higher errors, while combat films of Reference 5 showed rms aim errors of the order of 17 mils. If the difference between the test tracking errors and combat tracking errors had been small, it would have been reasonable to infer that differences in tracking performance shown in the tests would also show up in combat. However, the factors affecting large errors may well be different from the factors affecting small errors. The small errors may be small enough to lie within the range where resolution difficulties appear, both technical (the ability of the pilot to perceive and correct for small errors) and psychological (perhaps the pilot says, "So there's an error! It's too small to bother about. "). It is likely that the pilots can devote more of their attention to tracking in tests than in combat, and this may account, at least in part, for the smaller errors. This "attention factor" may have a profound effect on the tracking performance, and may produce results which bear little resemblance to what might be experienced in combat. This point will be dealt with later.

Finally, the small tracking errors practically invalidate a comparison of linear and non-linear operation of the yaw damper. It will be remembered that the non-linear yaw damper varied the damping of the Dutch roll as a function of sideslip, or lateral acceleration. If the rms aim error is small, the sideslip which is characteristic of the Dutch roll will also be small, and the difference between linear and non-linear yaw dampers becomes small or even nonexistent. It will be remembered that in some runs the sideslip remained so small that the yaw damper never became non-linear, although it was set for non-linear operation. Furthermore, the difference in the effect on the airplane's motion of the linear and non-linear yaw dampers becomes less noticeable for small errors, further distorting the results of the tests. Consider the case of a disturbance of the airplane away from the target. With a non-linear yaw

damper, the airplane returns toward the target at some angular rate which becomes smaller as the target is approached. With a linear yaw damper set to provide the same amount of damping that the non-linear yaw damper applied near zero error, the rate of return would be slower.

However, even at a relatively slow rate, the amount of time required for the nose to traverse a small angular error might be small simply because it did not have far to go. The time during which the nose was away from the target might be short enough to be acceptable to the pilot. In contrast, a large disturbance might make the difference in "time off target" between linear and non-linear operation become quite important to the pilot. Since the errors in these tracking tests were small compared to errors measured in combat, it is not possible to tell whether the non-linear feature of the yaw damper would be useful in combat. The tests neither prove nor disprove it; they are simply silent on the subject because they did not adequately cover the necessary conditions, specifically, disturbances comparable in size to those measured in combat operations.

It can be seen, then, that the fact the aim errors were small compared to combat aim errors casts doubt on the validity of the test results for several known reasons. The fact that the reason for the small errors is not positively known is another source of worry as to how well the test results can be carried over to combat conditions.

The disagreement between numerical measures of the tracking performance of an airplane and pilot opinion as to its suitability as a tracking airplane has been noted in other tests as well as in the tests reported here. As the damping of the Dutch roll is decreased the pilots rate the airplane as less and less suitable for tracking, and furthermore, can notice quite small changes in the damping of the airplane. The numerical results show little change in the tracking performance when the damping is decreased. For example, the comments of pilot C (Table VII) show quite a consistent variation in his impression of his ability to stay on the target as the Dutch roll damping of the airplane is varied. Measurements of his tracking errors, taken in the same runs during which his comments were collected, are plotted in Figure 18, and show little variation in his actual performance of that task. Presumably, what happens is that the

pilot supplies added damping through his controls as the damping of the airplane is decreased. In other words, he works harder and is able to keep his tracking score from deteriorating. The pilots, however, do not report merely that they had to work harder. They report that they had to work harder and that therefore the airplane was not as good for tracking as the Dutch roll damping decreased. It is believed, and this is borne out in conversations with the pilots, that they are taking into account the fact that their attention may be distracted in combat, and they are in this way putting back into the tests an important factor which was left out. Therefore, it would be a mistake to concentrate on the numerical results of these tests to the exclusion of the pilot opinion data.

The yaw damper, which changed the damping of the Dutch roll and made it non-linear when desired, operated smoothly and reliably and did not alter other characteristics of the airplane. The pilots were not confronted with peculiar rudder pedal forces, for example, which would have required conscious effort to ignore when rating the effects of varying the damping of the Dutch roll. Experience with tests in which variable stability equipment did produce undesirable side effects indicated that it is worth going to considerable trouble to make the test system free of side effects. As pointed out above, the job of evaluating tracking test results is inherently difficult enough without adding uncertainties over how much some side effects of the equipment have influenced the results. The pilots mentioned this same point.

To summarize, these tests were conducted in what has become a fairly standard manner. It is believed that, in some manner not presently understood, the test technique neglects several factors which are important in tracking, and that the results of the tests are therefore not as conclusive as one would desire. The fact that some factors are missing distorts the relationship between several factors which were accounted for, leading to conclusions which may be incorrect. It is believed that what is needed is a more basic study of the tracking problem aimed at producing a test technique which will account for all the important variables. The problem is two-headed; first the variables must be identified, and, second, ways of including them in the tests must be developed.

~~CONFIDENTIAL~~

CONCLUSIONS

1. Tracking aim errors were reduced to about two-thirds the value experienced with the normal airplane by increasing the damping of the Dutch roll to about 70% critical damping.
2. Increasing the damping of the Dutch roll from 70% to 100% critical damping did not appreciably reduce the tracking errors.
3. Making the damping non-linear did not materially reduce the tracking errors, although the pilots showed some preference for the non-linear damping. However, the difference between linear and non-linear damping would hardly be expected to be noticed for the small tracking aim errors measured in these tests.
4. The tracking aim errors measured in these tests were only about one-fifth of tracking errors measured in combat. It is suspected that the smallness of the errors exerted a profound influence on the results of the tests and that the results must be used with caution.
5. The tracking aim errors do not vary as much with damping of the Dutch roll motion as pilot comments, made during the tracking run, would lead one to expect. It is believed that the discrepancy is significant. It is suspected that the pilots may be allowing, in their opinions, for the possibility that the tension and distraction of combat may not permit them to concentrate upon tracking as much as they did in these tests. The freedom to concentrate presumably helped to produce good scores in the tests regardless of the damping of the Dutch roll motion of the airplane.
6. Use of a test vehicle in which the means for varying the desired characteristics produces the minimum of side effects is important in tracking tests. The installation in the airplane used for these tests was singularly free from such undesired side effects. The pilots stated that the simulated normal airplane felt almost identical to the actual normal airplane. The problem of tracking appears to be sufficiently complicated to make it important that side effects are not present so they will not affect the main results.

REFERENCES

1. Statler, I. C. and Beilman, J. L. Dynamic Lateral Stability Through Non-Linear Automatic Control. Cornell Aeronautical Laboratory Report TB-697-F-1 January 1952 (Confidential)
2. Thayer, W. J. and Muzzey, C. L. Flight Control Servo Development. Cornell Aeronautical Laboratory Report CAL-63 July 1954
3. Bull, G. and Kidd, E. A. Vibration Tests of EF-86E, Serial Number 50-588. Cornell Aeronautical Laboratory Flight Research Memorandum 207 April 1954
4. Weiss, H. K. Analysis of Tracking Errors. Ballistic Research Laboratories Report 649 September 1947 (Confidential)
5. Weiss, H. K. Analysis of World War II Air Combat Records. Ballistic Research Laboratories Report 727 July 1950 (Confidential)
6. Storms, H. A. Estimated Aerodynamic Characteristics For Design of the F-86E Airplane. North American Aviation, Inc. Report NA-50-1277 December 1950
7. Johnston, E. W. F-86E Characteristics for Lateral Directional Dynamic Stability Studies. North American Aviation, Inc. Report NA-52-286 March 1952
8. McNeill, W. E. and Cooper, G. E. A Comparison of the Measured and Predicted Lateral Oscillatory Characteristics of a 35° Swept Wing Fighter Airplane. NACA RM A51C28 1951 (Confidential)

APPENDIX

Theoretical Analysis

A theoretical analysis was made of the behavior of the airplane with the non-linear yaw damper and had three objectives:

1. Choose a suitable type of non-linearity.
2. Determine the sensitivities and other system characteristics necessary to produce the desired response.
3. Determine the effect on the motion of the airplane of variations in operating conditions to provide a basis for designing a system which would take these variations into account.

The plan used in the theoretical analysis is outlined below. Each step will be discussed more completely in subsequent paragraphs.

1. Assumptions were made of the flight conditions (Mach number and altitude) which were of interest, and of the general method of achieving the desired non-linearity. The latter assumption was based on experience gained in previous phases of the project in which a non-linear yaw damper for an F4U airplane was designed, built and operated.
2. The equations of motion of the airplane were set up to include the yaw damper, allowing for inputs from gusts and rudder motion and for the effects of servo dynamics.
3. Stability derivatives based on wind tunnel and flight tests were obtained from North American Aviation (References 6 and 7) and selected NACA reports.
4. With the assumption of a single degree of freedom system (no roll, no lateral displacement) the damping of the yawing motion of the airplane was computed. The damping of the yawing motion was also computed for the case of a perfect yaw damper with one value of sensitivity.
5. At operating conditions covering the extremes of likely operations of the airplane, analog computer investigation of various damping schemes was carried out. Both yaw rate and rate of change of sideslip were

considered as inputs to a linear system and the response of the airplane to disturbances in control motion and sideslip as well as unsymmetrical gusts was determined. The object of this set of computations was to select the best of several possible schemes for providing the damping.

6. In producing the non-linearity in the yaw damper, either lateral acceleration (n_y) or sideslip ($n_y/q \approx \beta$) could be used. Analog computations were made of the response of the airplane with each of these quantities used as the input, to determine if n_y , the simpler of the two quantities to measure, would be satisfactory, or if a q dividing circuit would have to be provided to furnish a signal of the form of n_y/q or approximately β .
7. Analog computations were made of the response of the airplane to step aileron deflections using rudder to neutralize the disturbing yawing moment due to aileron deflection.
8. The computations outlined above were made for the case of a perfect servo in the yaw damper and for the case of a servo with an assumed first order lag.
9. An analog computer study was made to show how variations in the servo dynamics affected the motion of the servo controlled airplane. The purpose of these calculations was to determine the requirements the servo system would have to meet.

EQUATIONS OF MOTION

The equations of motion which were used in the analog computations are given in Table A-I. The symbols are defined in Table A-II. It will be noticed that the inclination of the principal axes was taken into account. The cross coupling effect due to the inclination of the sensitive axis of the yaw rate gyro with respect to the airplane's flight path was also included.

Many of the analog computations were made for the trim tab system in which the servo moved the rudder indirectly by means of the trim tab. Many of the results could be carried over directly to the case of the "rudder" system, in which the servo drove the rudder directly. The important thing was that the

rudder was moved in some prescribed fashion, and whether the servo moved the rudder directly or by means of the trim tab, had no effect on the motion of the airplane.

The inputs used to disturb the airplane were:

1. Pulses in aileron motion, to represent a disturbance applied by the pilot.
2. Steps in sideslip, to represent a lateral gust.
3. A change in sideslip with a structure as shown below, to represent a more gradual gust than in (2) above.

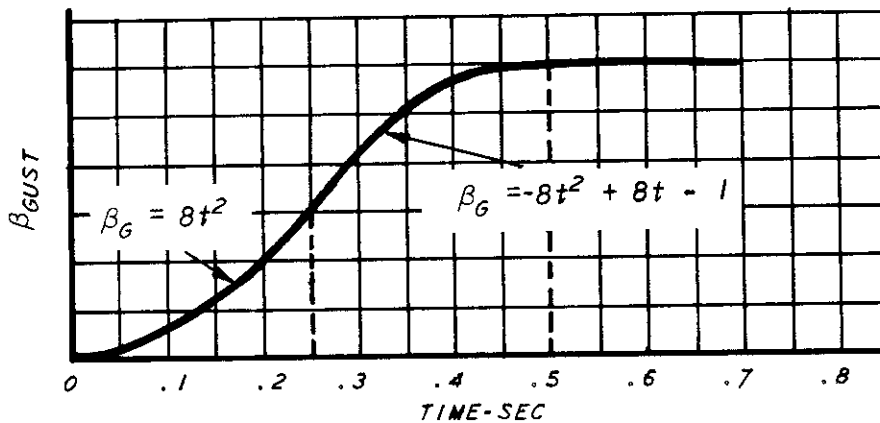

4. An applied rolling acceleration to represent an unsymmetrical vertical gust.

When a yaw rate sensing device is used as the signal source for a yaw damper, some scheme must be devised to prevent it from opposing a turn which is desired by the pilot. One scheme investigated for this yaw damper was to pass the signals from the yaw rate gyro through a filter which rejected steady or very low frequency signals but passed the higher frequency signals due to the motion in the Dutch roll or the response of the airplane to gusts. The effect of this filter upon the motion of the servo controlled airplane is accounted for in equation (5b).

Another scheme investigated was one in which the rudder was moved proportional to the difference between yaw rate and a function of bank angle. The idea was that a rate of turn desired by the pilot would always be accompanied by a

bank angle determined by the rate of turn and true airspeed. Therefore, a yaw rate accompanied by the proper bank angle meant that the pilot wanted this condition, and the yaw damper did not oppose the turn, while a yaw rate not accompanied by the proper bank angle caused the yaw damper to operate the rudder to decrease the yaw rate. The mathematical method for handling this scheme is given in equation (6).

The dynamics of the servo are included in equation (7).

Results of the Calculations

COMPARISON OF YAW RATE VS. RATE CHANGE OF SIDESLIP SENSING

Two quantities which might be used as the primary signal for a yaw damper are yaw rate and rate of change of sideslip. Each has specific advantages. In the lateral-directional oscillation, or Dutch roll, the two quantities amount to about the same thing as far as providing a signal to a yaw damper is concerned. In a steady turn, a yaw rate sensing device puts out a signal to move the rudder to decrease the yaw rate, or in other words, to stop the turn. If the pilot wants to make a turn he must either overpower the servo to prevent it from moving the rudder to stop the turn, or some scheme must be provided to discriminate between the unwanted motion of the Dutch roll and the motion desired by the pilot. A signal proportional to rate of change of sideslip does not oppose a steady turn since sideslip should not exist in a turn, as yaw rate does, so no schemes to correct for this effect need to be considered. However, if the airplane encounters a gust with a component producing some sideslip (and such gusts are common) the device sensing rate of change of sideslip will move the rudder to reduce this rate, which will have the effect of making the airplane turn into the gust. If the pilot is trying to track a target in rough air it will be detrimental to have the yaw damper attempting to turn the airplane away from the target to head it into every gust. Therefore, yaw rate was used as the primary signal for damping the Dutch roll, and means were provided to suppress the signals due to yaw rate desired by the pilot.

Both schemes for eliminating the tendency of the yaw damper to oppose the

pilot in a turn worked satisfactorily as far as the analog calculations showed. The filter was a simpler solution than measuring bank angle and generating the necessary function of bank angle so, since both schemes appeared to be satisfactory, the former was chosen.

The dynamic requirements which the servo would have to meet in order for it to move the rudder properly were determined by varying the servo natural frequency in equation (7), and noticing how low the natural frequency could be made before the response of the airplane began to be appreciably affected. A natural frequency of about 10 cps was found to be necessary for a servo with 70% critical damping. This damping is the damping of the servo loop itself, not the damping of the Dutch roll motion of the airplane. The 10 cps natural frequency requirement seems rather severe, in view of the fact that the natural frequency of the airplane Dutch roll oscillation is only about $\frac{1}{2}$ to 1 cps. The more severe requirement is explained by the assumption that the pilot may demand more rapid motion in response to his rudder pedal forces, and that the non-linear operation of the yaw damper requires a rudder motion which includes frequency components which are higher than the frequency of the oscillation of the airplane. A linear yaw damper, of course, would require rudder motion only of the frequency of the motion being damped; however, the servo natural frequency would still have to be considerably higher than that of the motion to be damped to provide the required minimum phase lag.

The calculated response of the airplane to step aileron motions showed that the airplane motion was affected by the yawing moment due to aileron deflection. The amount of rudder motion proportional to aileron motion necessary to cancel the yaw due to aileron motion was found by cut and try methods on the analog computer. The ratio of rudder to aileron motion was varied until the amount producing minimum lateral acceleration was found.

When lateral acceleration instead of sideslip (n_y instead of n_y/q where $n_y/q \approx \beta$) was used to produce the non-linear function which modified the yaw rate signal, the analog computations showed that the motion of the airplane was not what was desired. The damping of the Dutch roll varied too much with dynamic pressure. Therefore, the additional complication of dividing the lateral acceleration by the dynamic pressure was accepted as necessary.

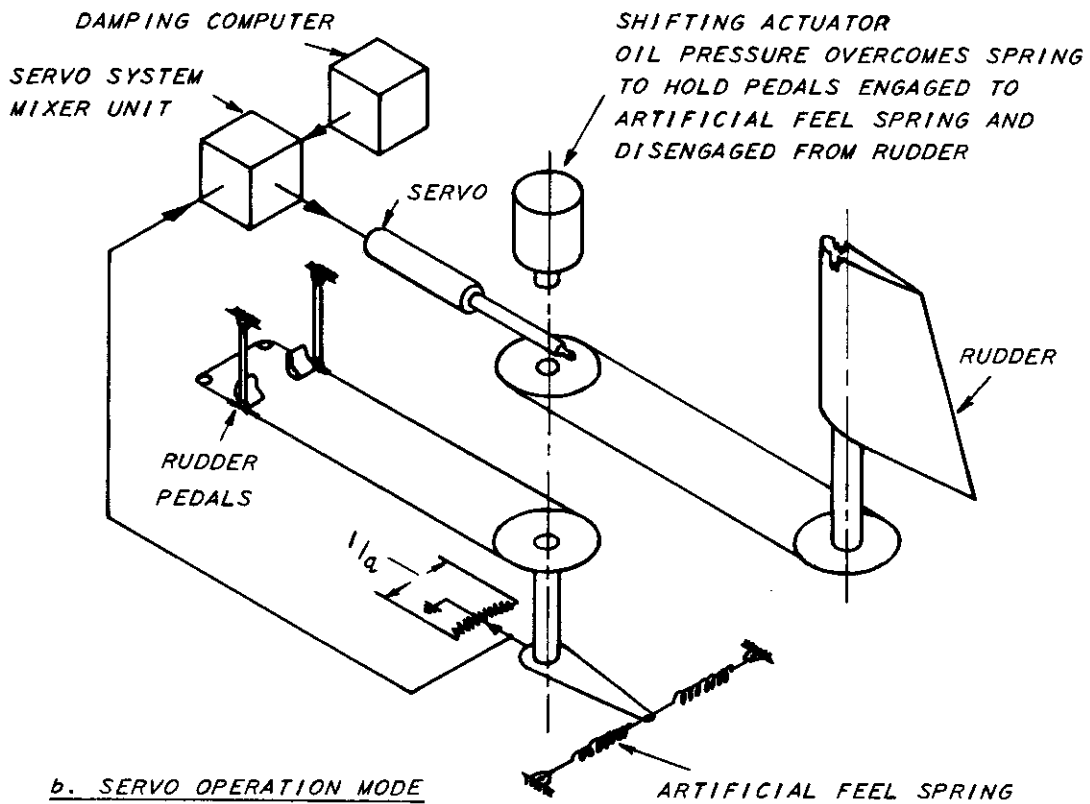
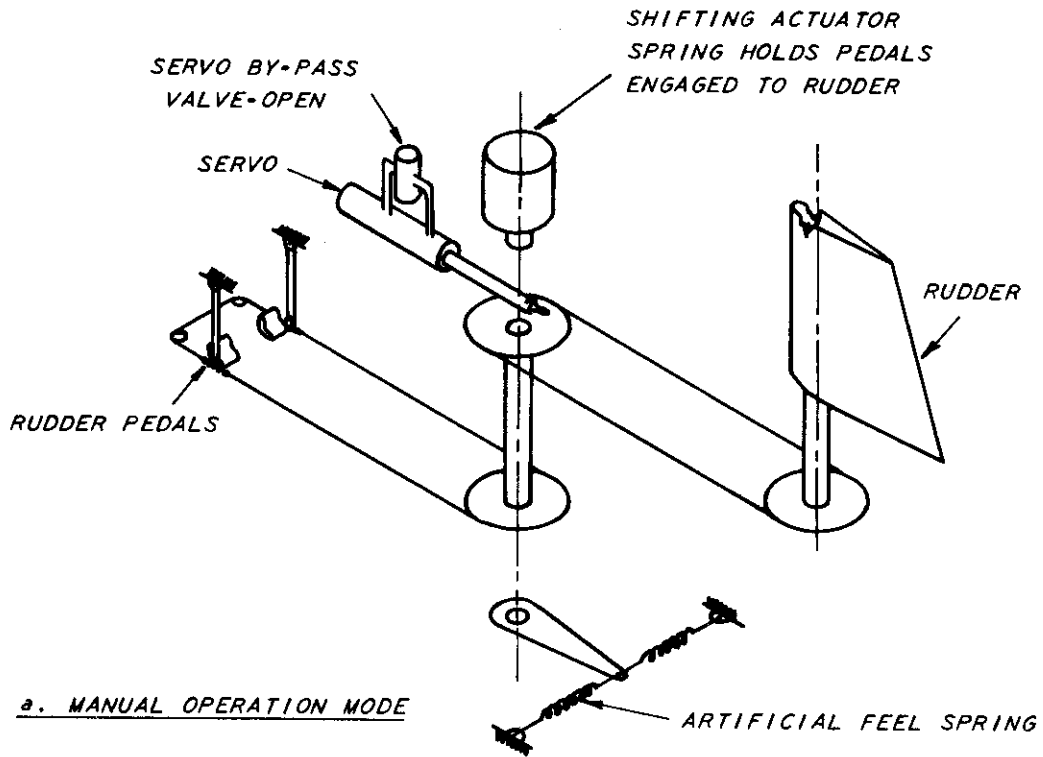

Fig. 1 SCHEMATIC DRAWING OF RUDDER SERVO INSTALLATION

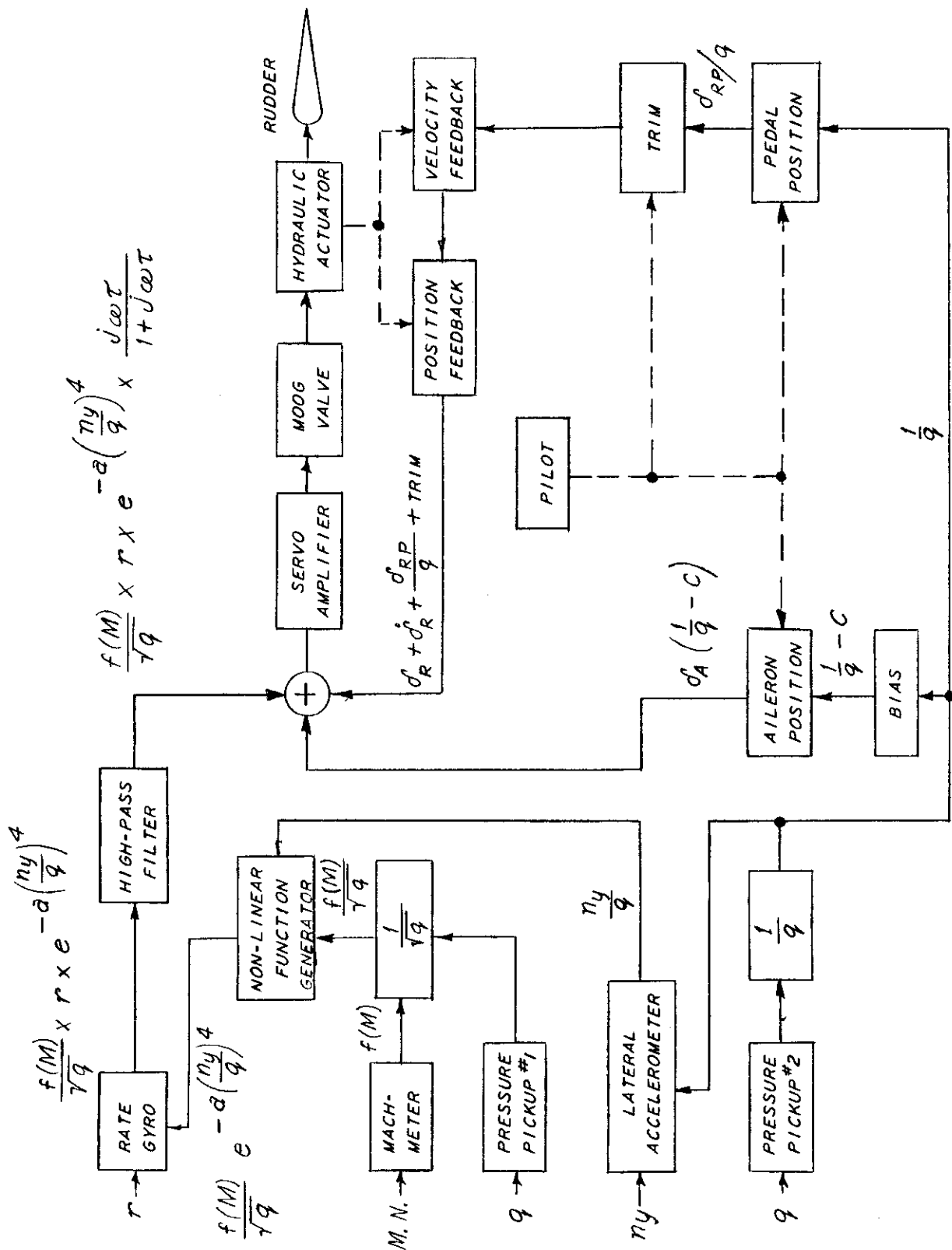

FIG. 2 BLOCK DIAGRAM OF NON-LINEAR YAW DAMPER SYSTEM

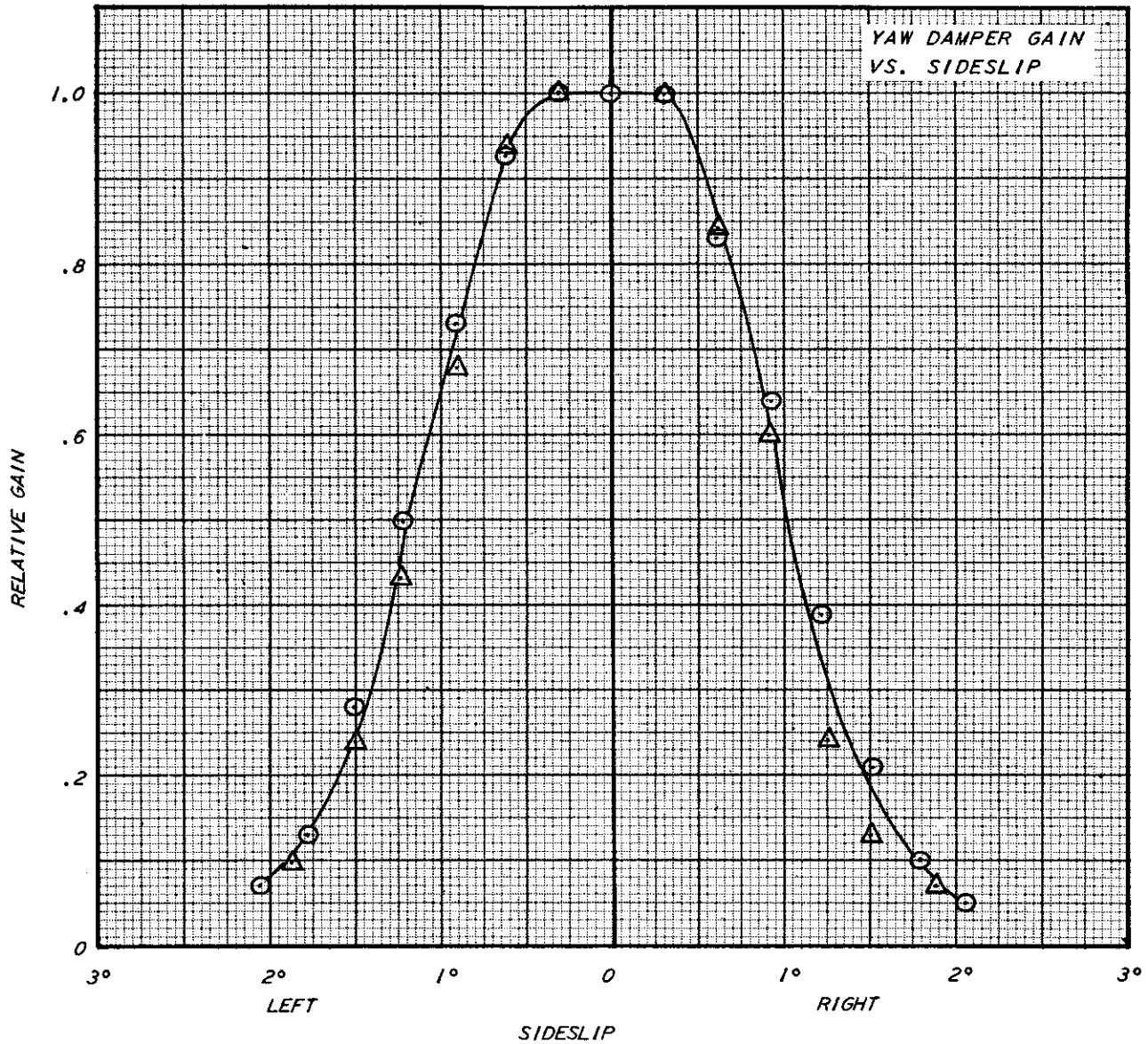

Fig. 3 MANNER IN WHICH YAW DAMPER GAIN WAS VARIED TO MAKE IT NON-LINEAR

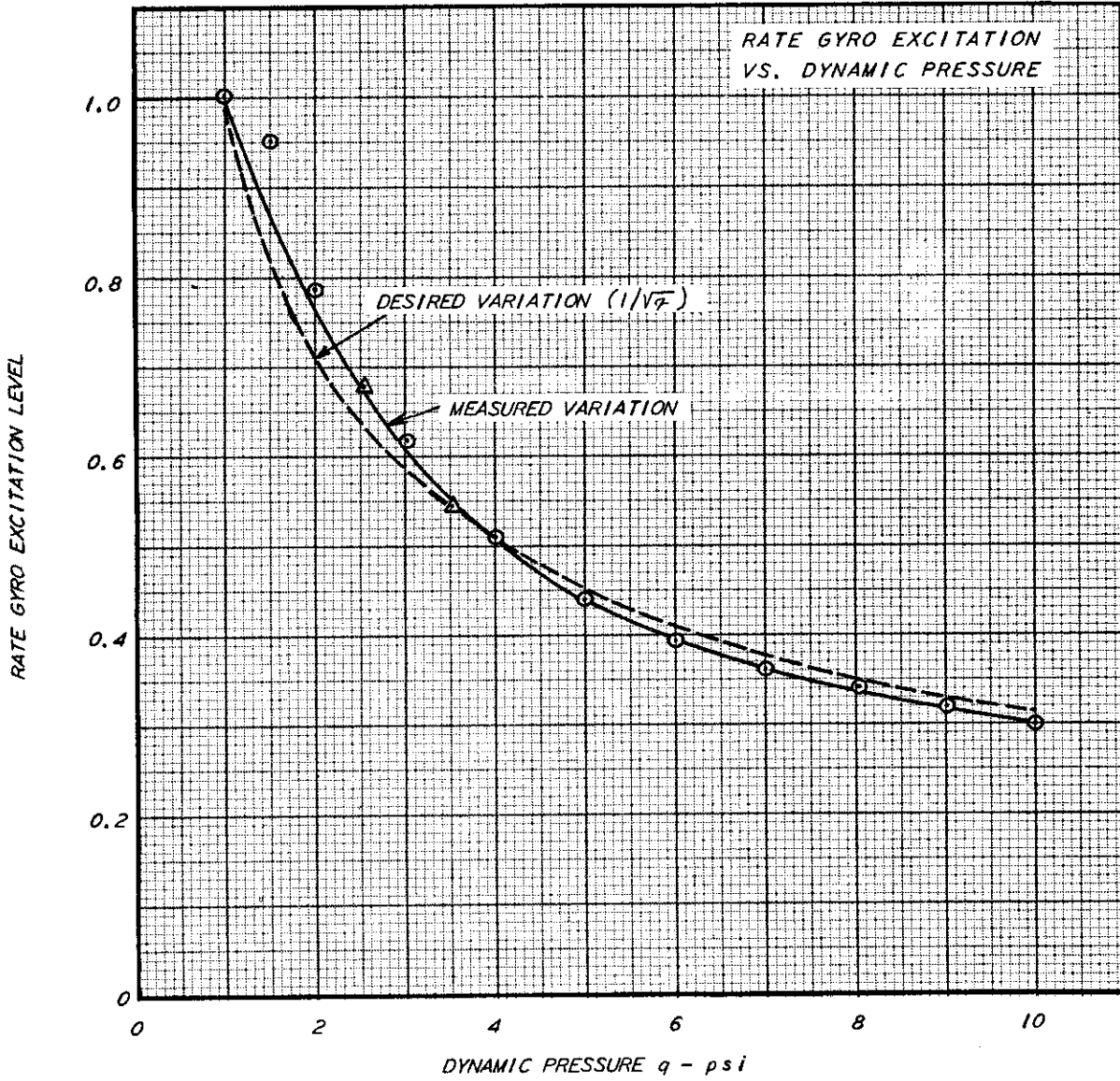

Fig. 4 VARIATION OF RATE GYRO SENSITIVITY WITH DYNAMIC PRESSURE

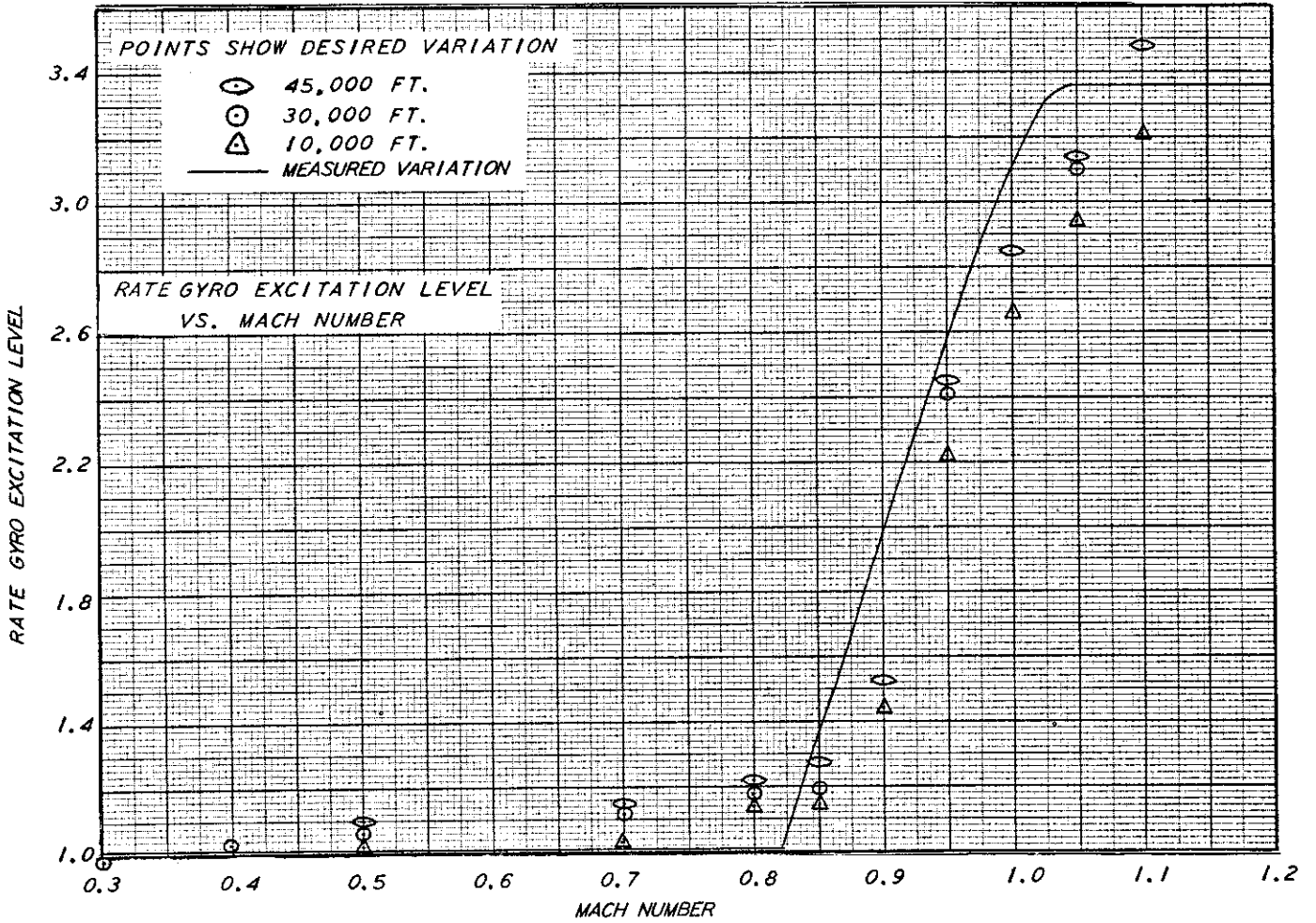

Fig. 5 VARIATION OF RATE GYRO SENSITIVITY WITH MACH NUMBER

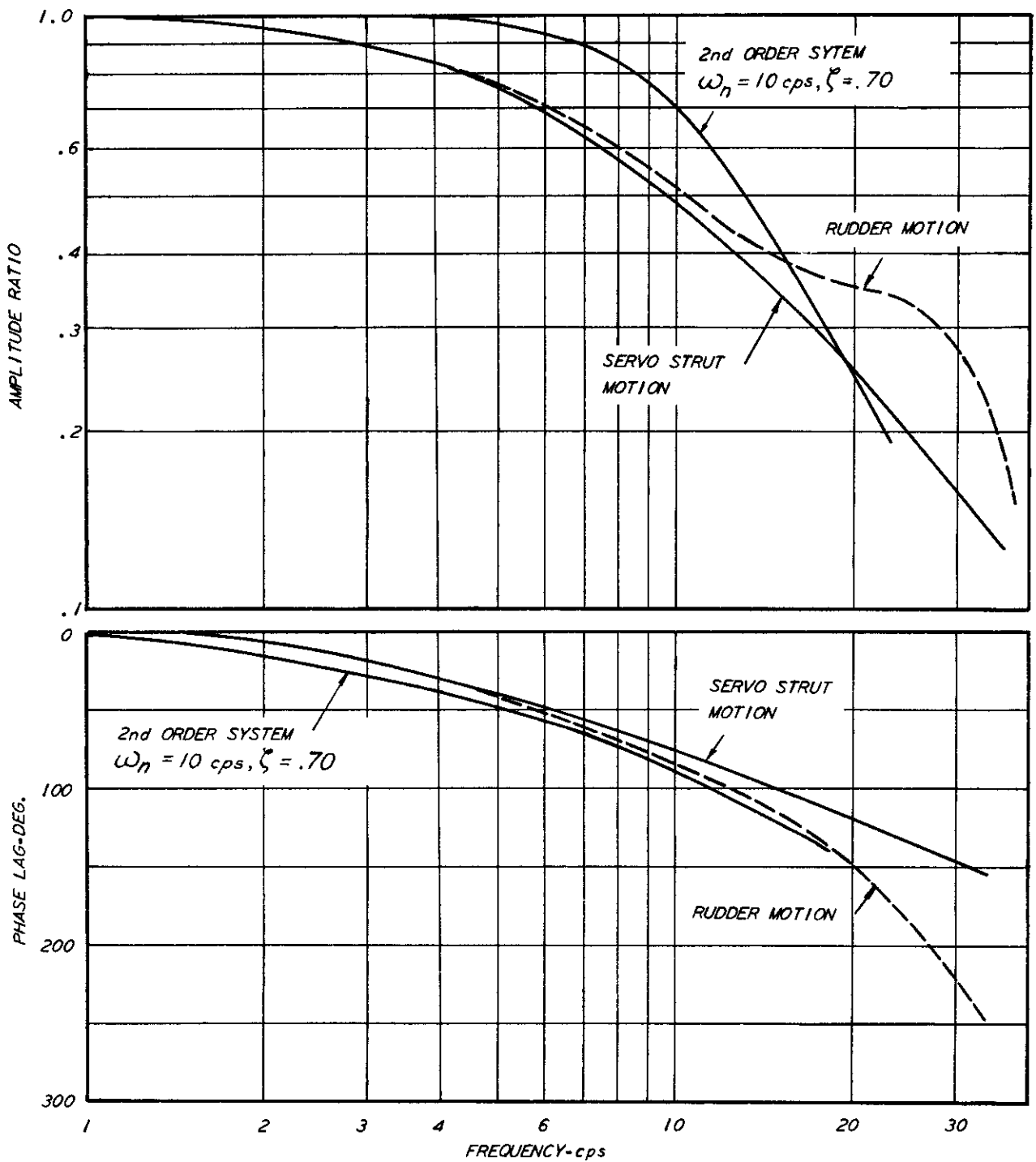

Fig. 6 FREQUENCY RESPONSE OF YAW DAMPER SERVO SYSTEM

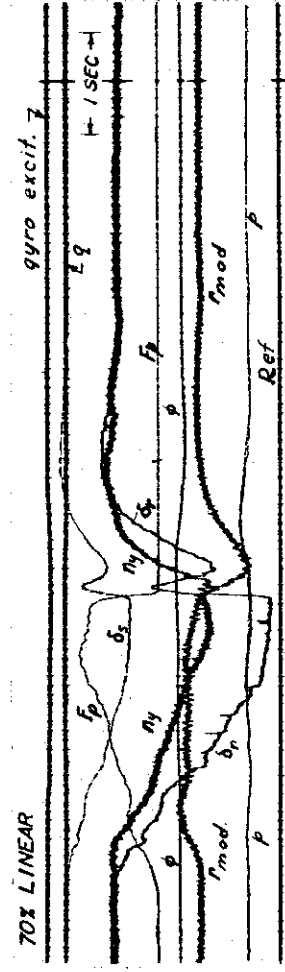
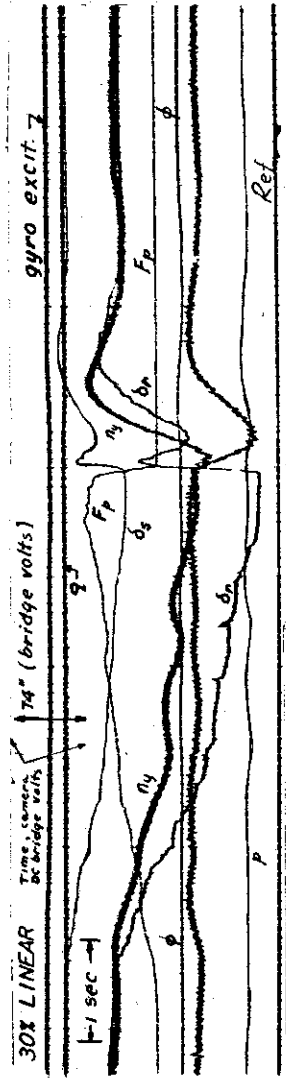
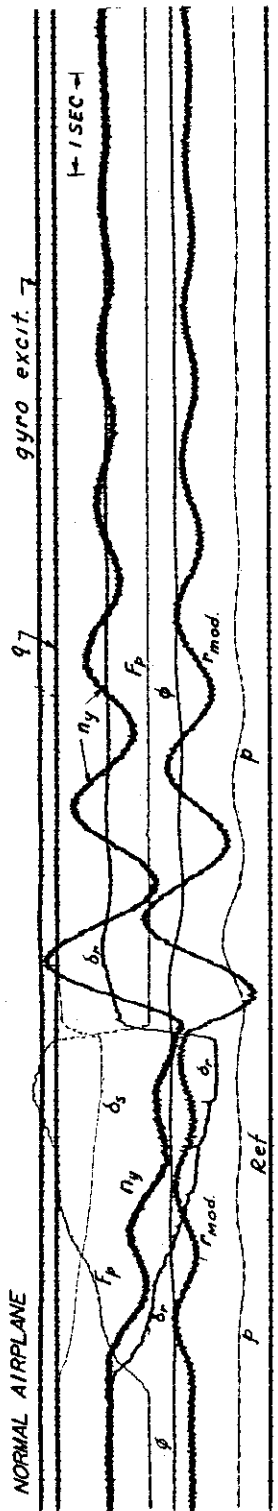

Fig. 7 FLIGHT RECORDS SHOWING EFFECT OF LINEAR YAW DAMPER

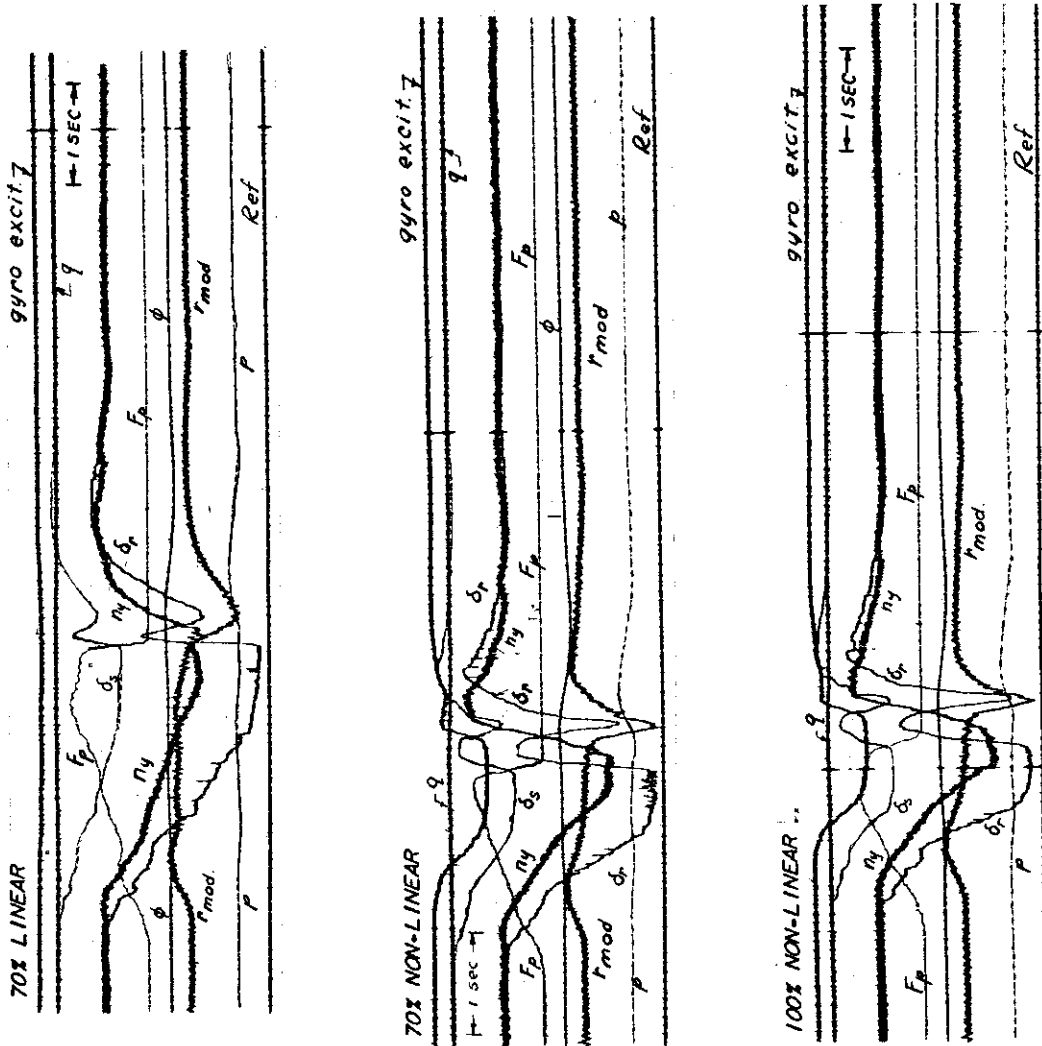

Fig. 8 FLIGHT RECORDS COMPARING EFFECT OF LINEAR AND NON-LINEAR YAW DAMPER OPERATION

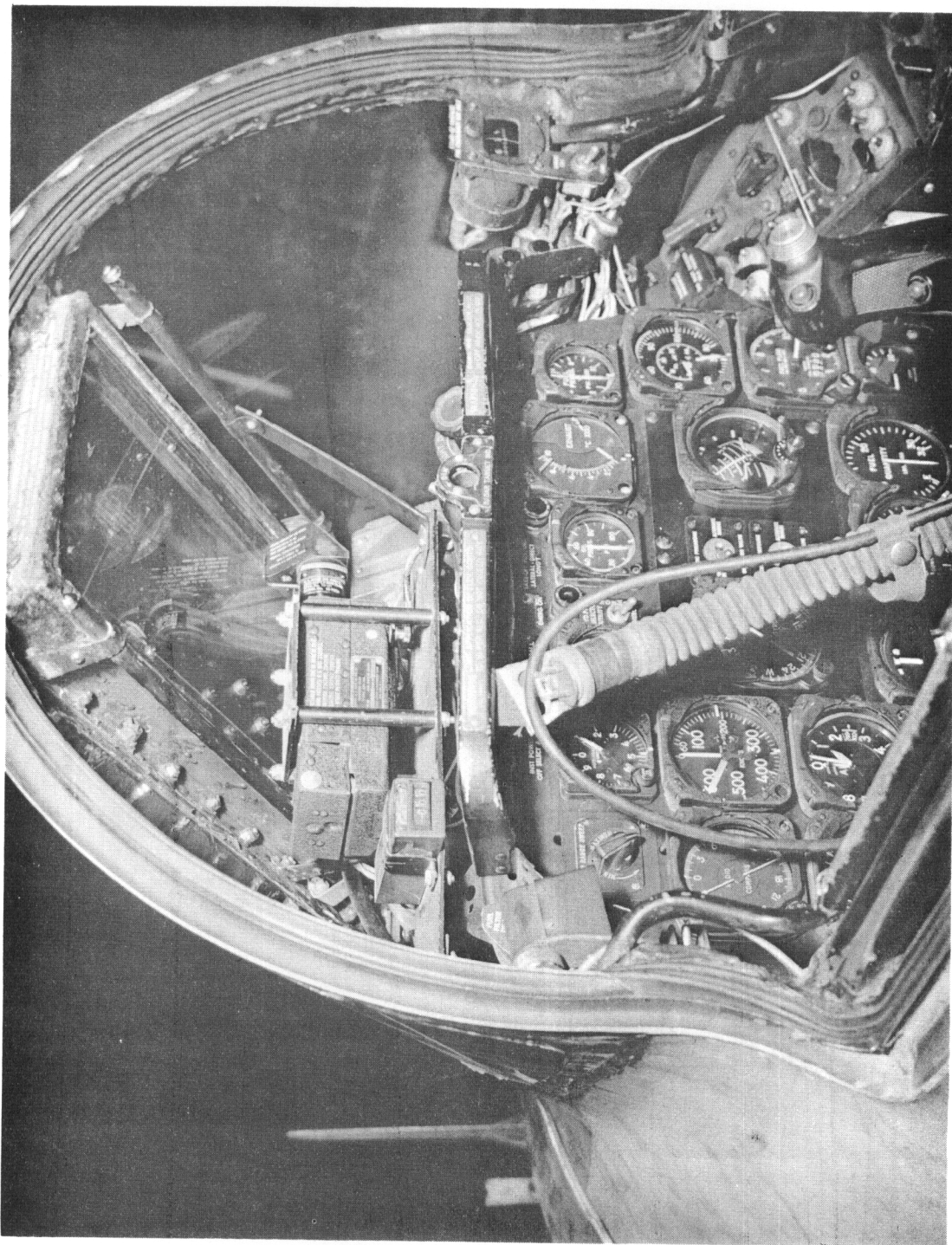

Fig. 9 TRACKING CAMERA INSTALLATION

Continuity

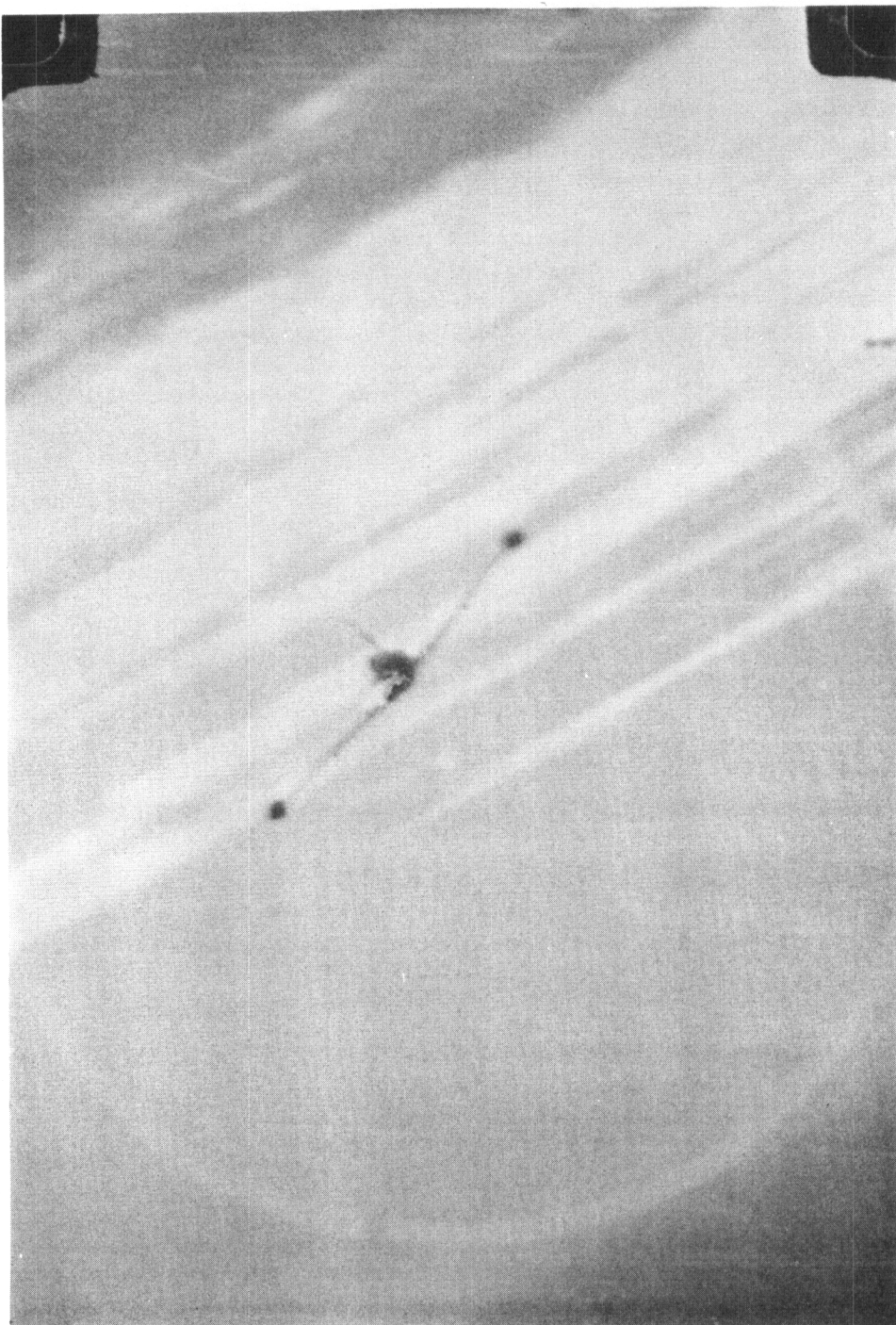

Fig. 10 SAMPLE TRACKING CAMERA PICTURE

Continuity

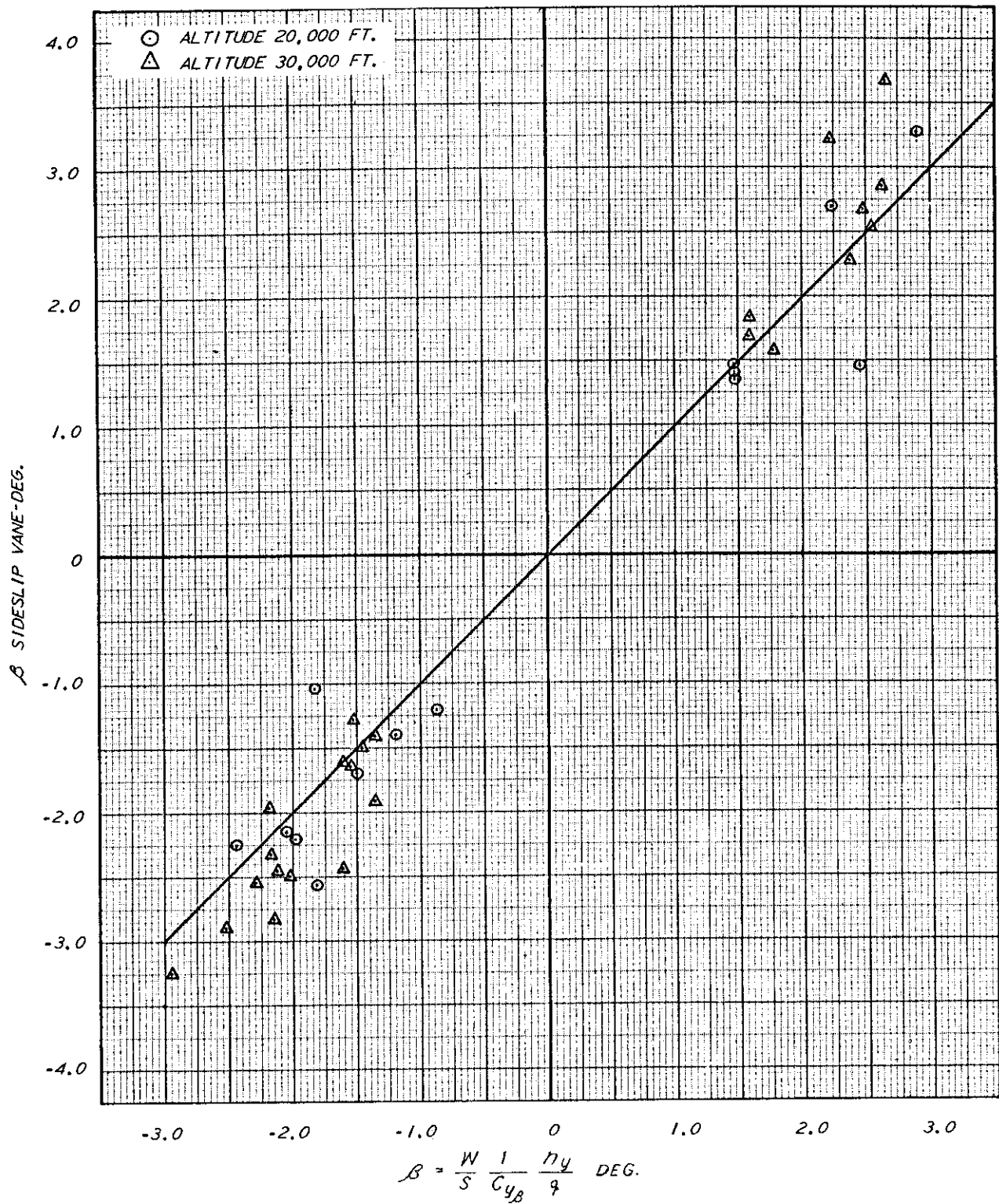

Fig. 11 COMPARISON OF SIDESLIP CALCULATED FROM LATERAL ACCELERATION WITH SIDESLIP MEASURED BY VANE

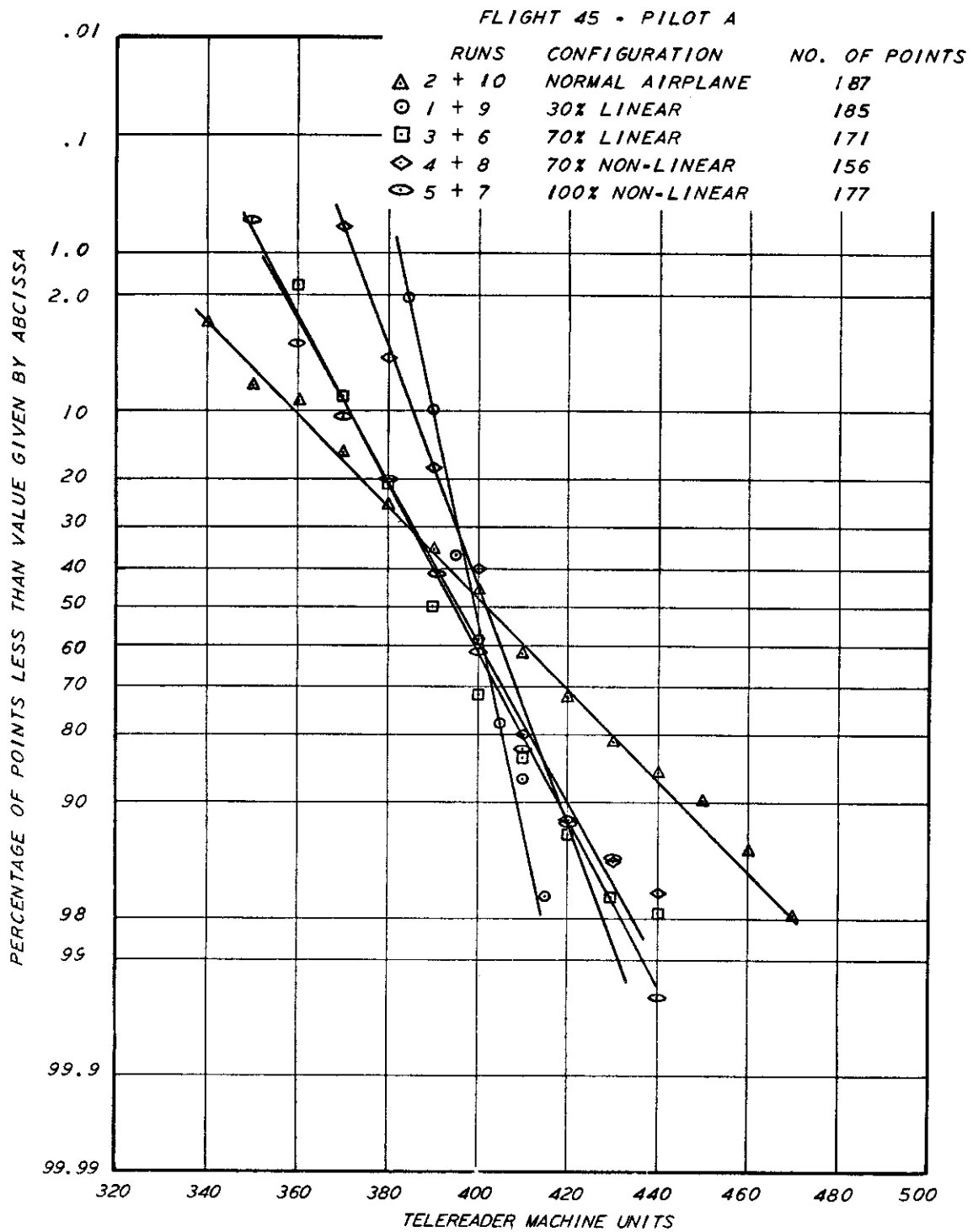

Fig. 12 DEMONSTRATION OF STATISTICAL NORMALITY OF TRACKING DATA

Confidential

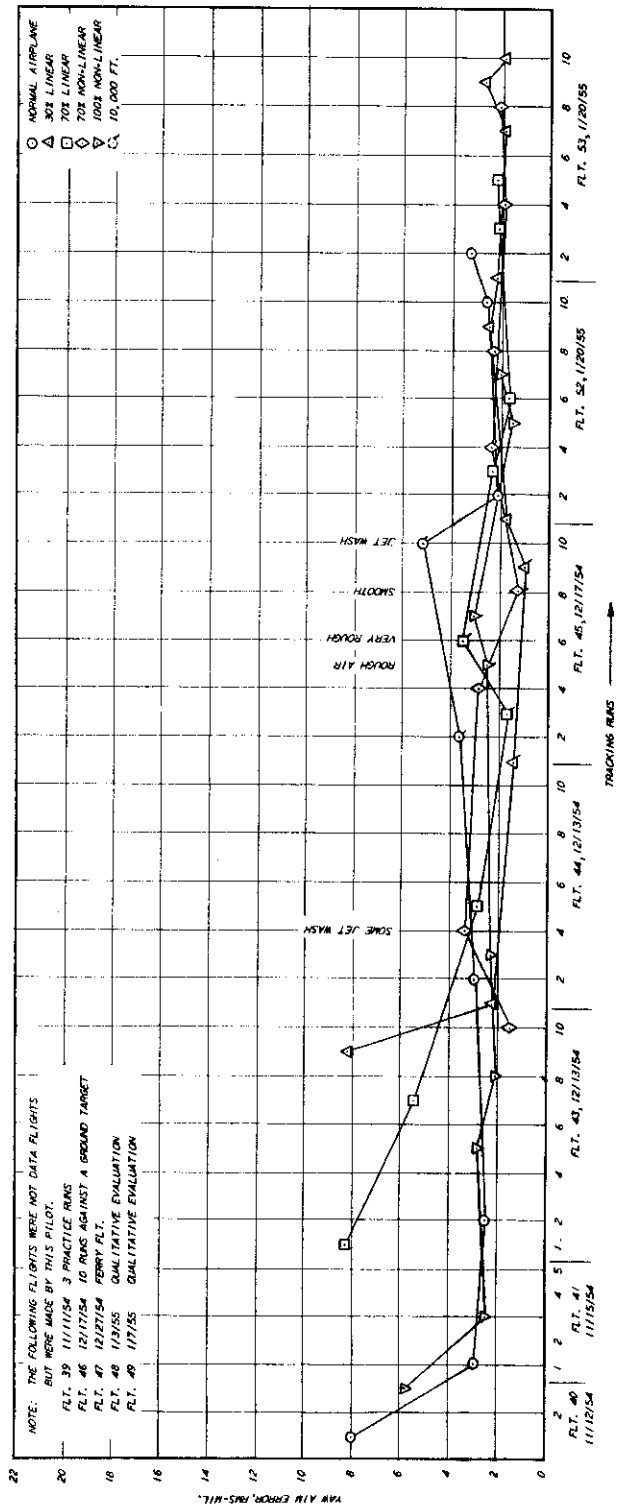

Fig. 13 AIM ERROR VS NUMBER OF TRACKING RUNS-PILOT A
 25,000 FT.
 DATA FROM TURN PORTION OF MANEUVER

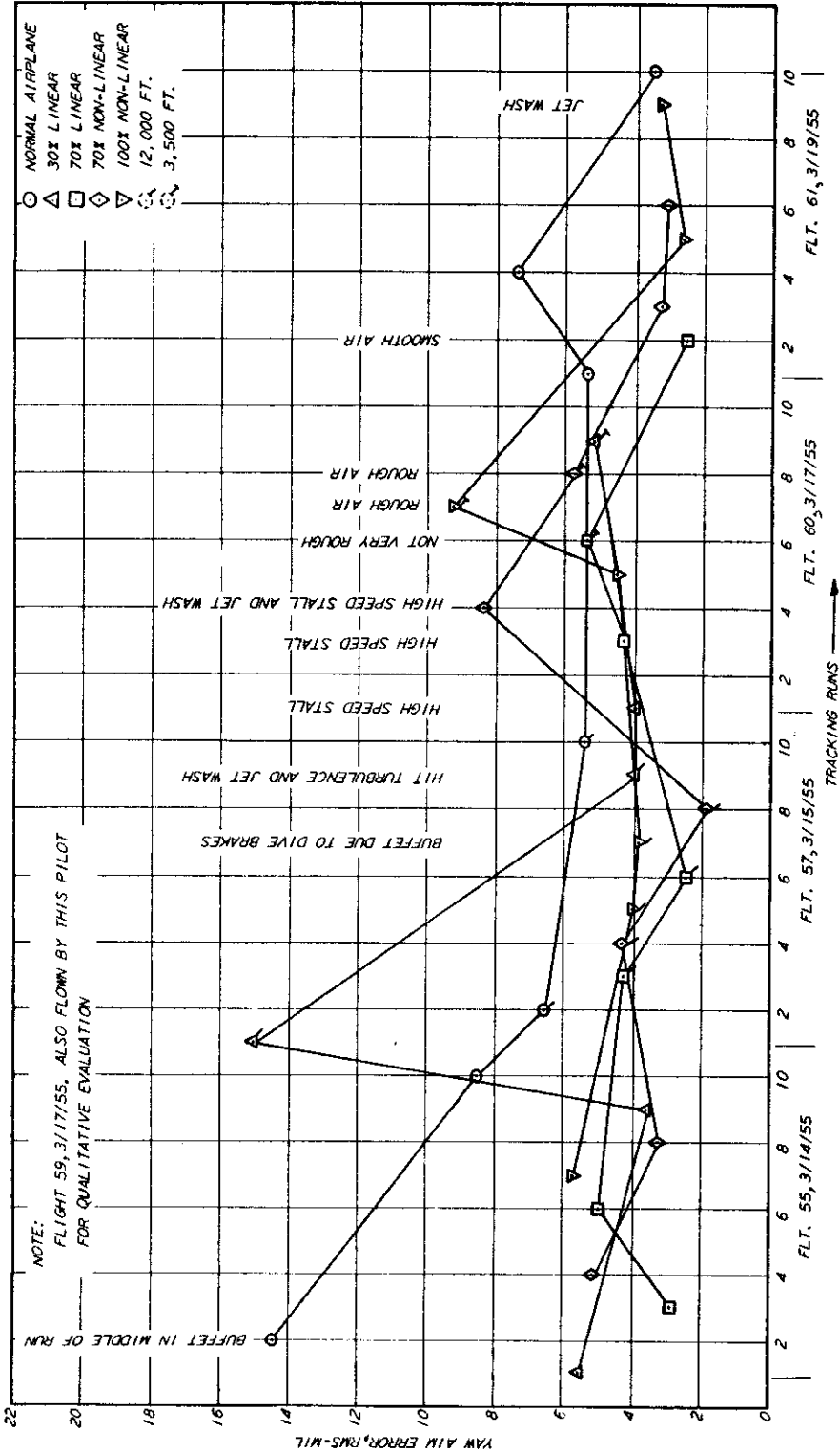
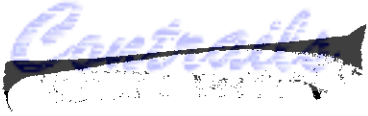

Fig. 14 AIM ERROR vs NUMBER OF TRACKING RUNS-PILOT B

25,000 FT.

DATA FROM TURN PORTION OF MANEUVER

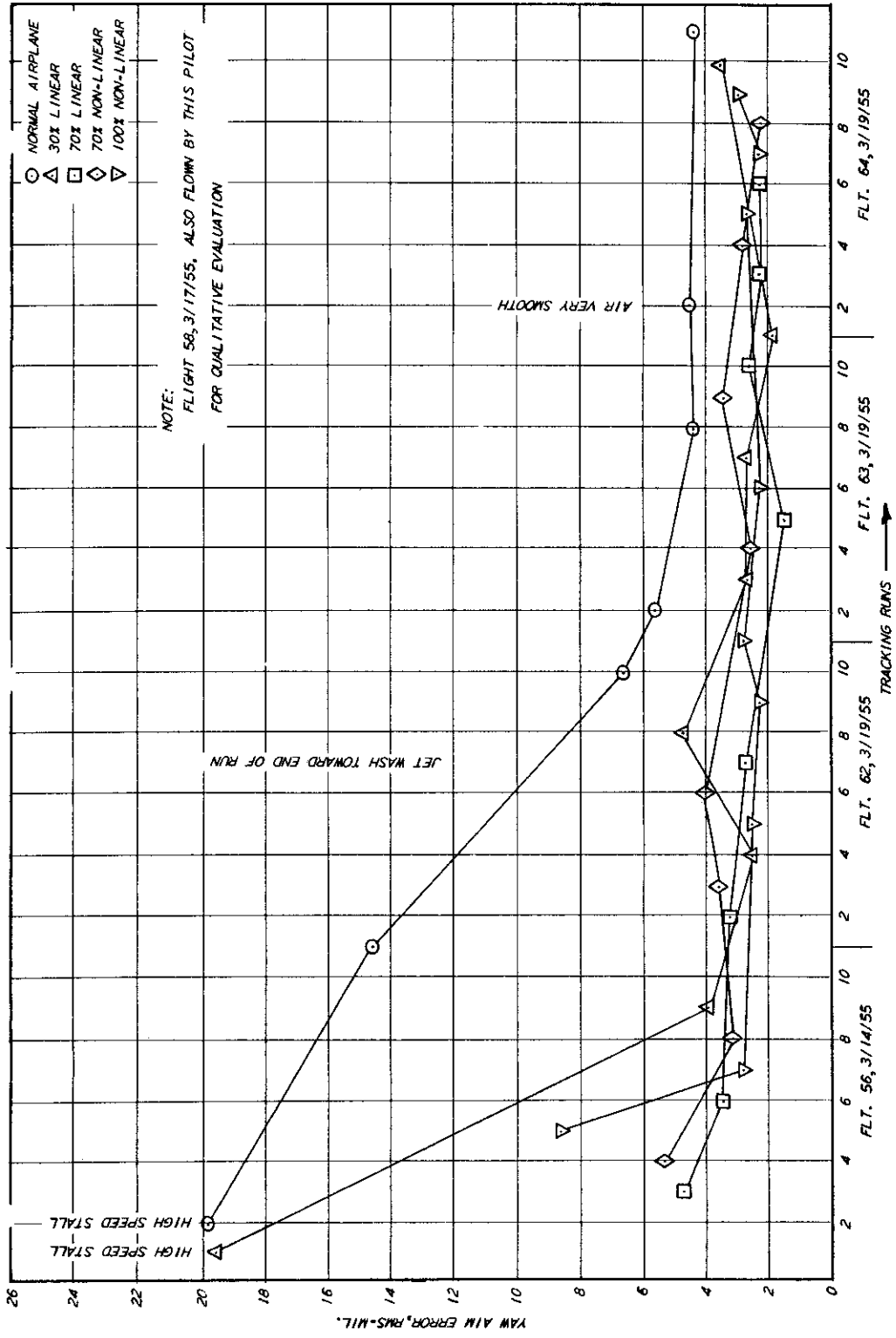

Fig. 15 AIM ERROR VS NUMBER OF TRACKING RUNS-PILOT C

25,000 FT.

DATA FROM TURN PORTION OF MANEUVER

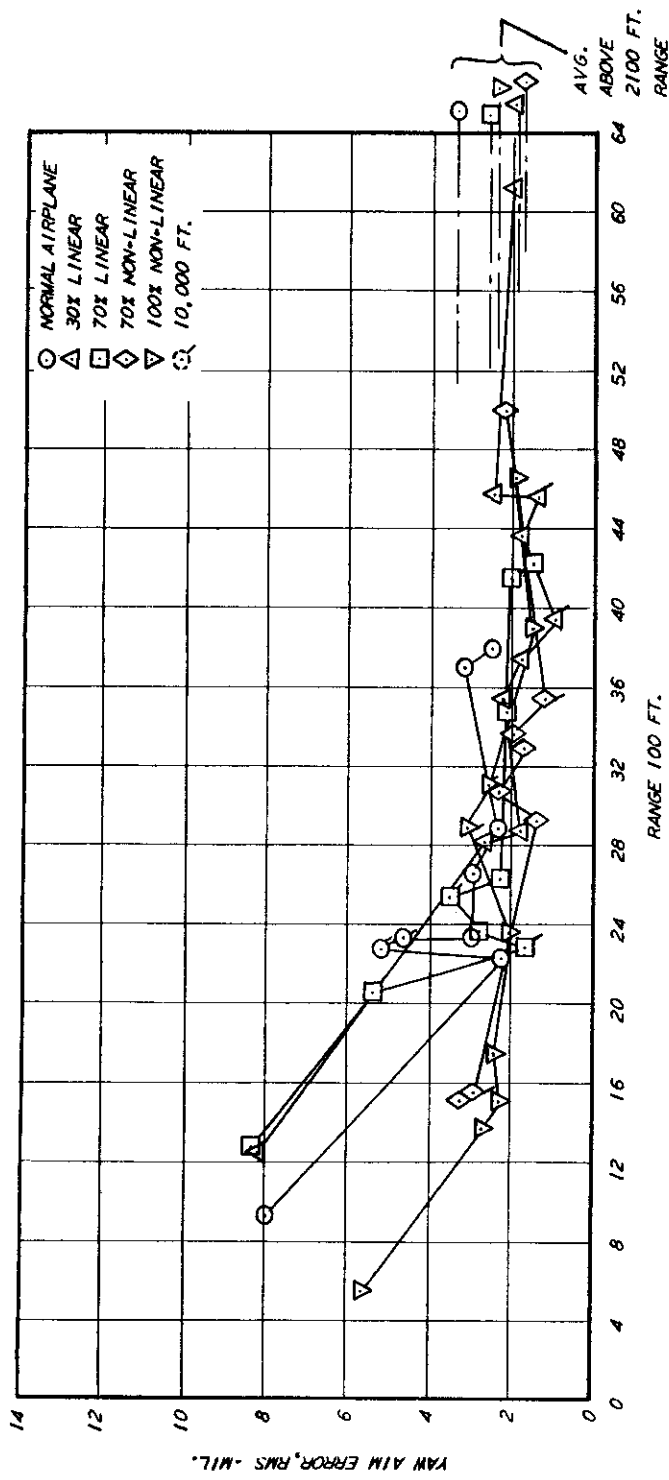

Fig. 16 AIM ERROR VS RANGE - PILOT A
DATA FROM TURN PORTION OF TRACKING MANEUVER
25,000 FT.
RANGE IS AVERAGE OF RANGE AT BEGINNING AND END OF RUN

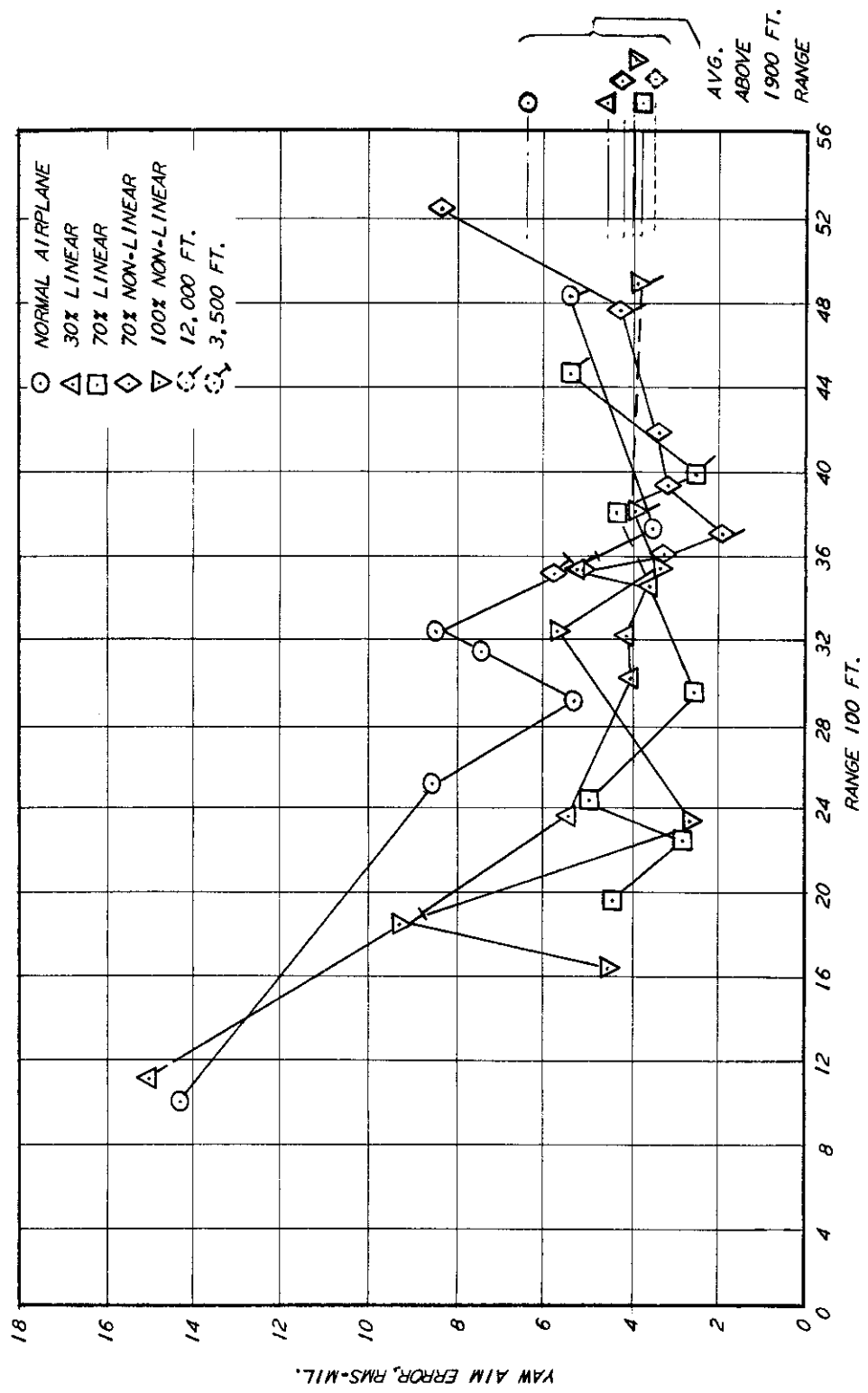

Fig. 17, AIM ERROR VS RANGE - PILOT B
 DATA FROM TURN PORTION OF MANEUVER
 25,000 FT.
 RANGE IS AVERAGE OF RANGE AT BEGINNING AND END OF RUN

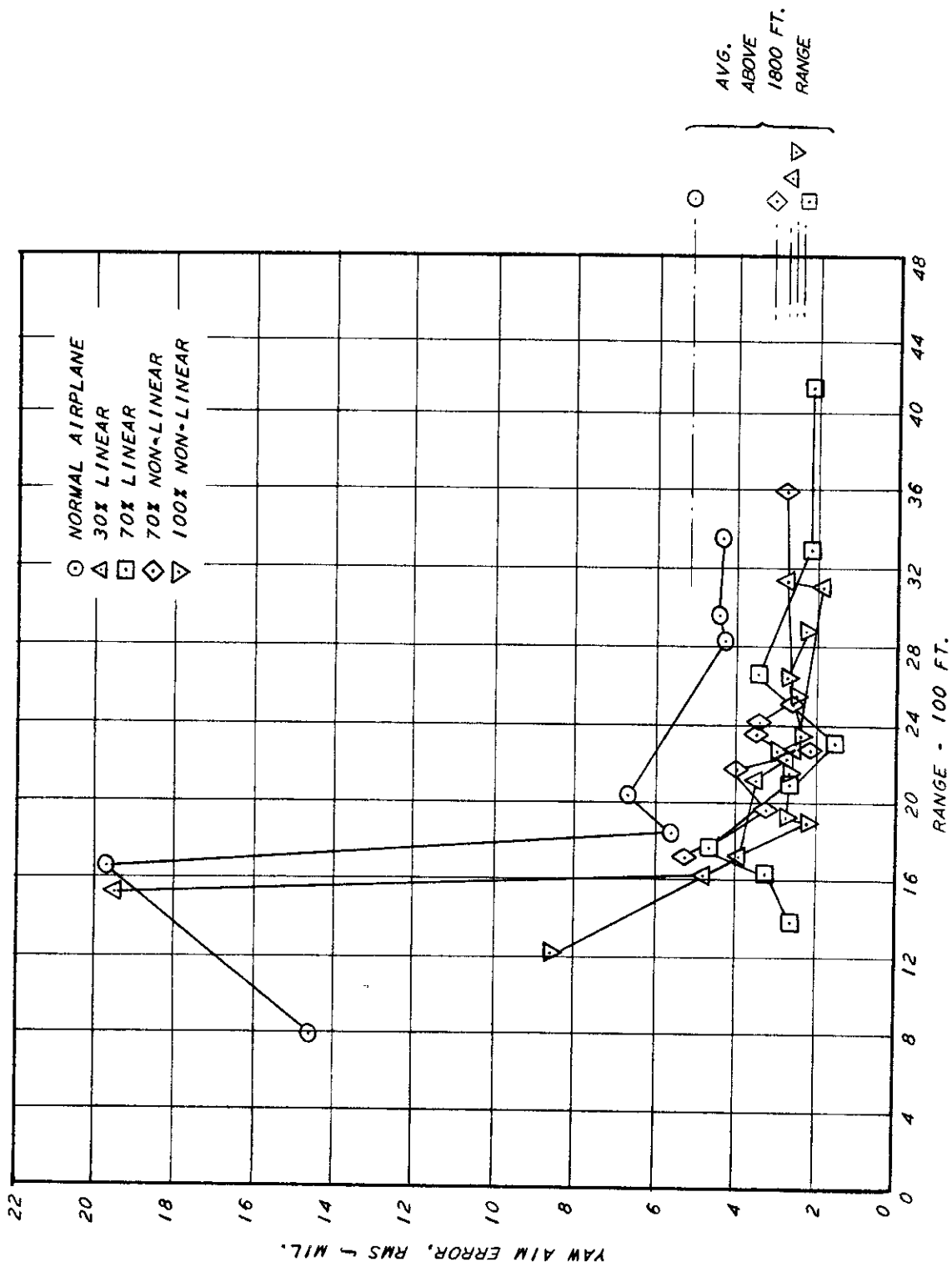

Fig. 18 AIM ERROR VS. RANGE. - PILOT C
 DATA FROM TURN PORTION OF MANEUVER
 25,000 FT.
 RANGE IS AVERAGE OF RANGE AT BEGINNING AND END OF RUN

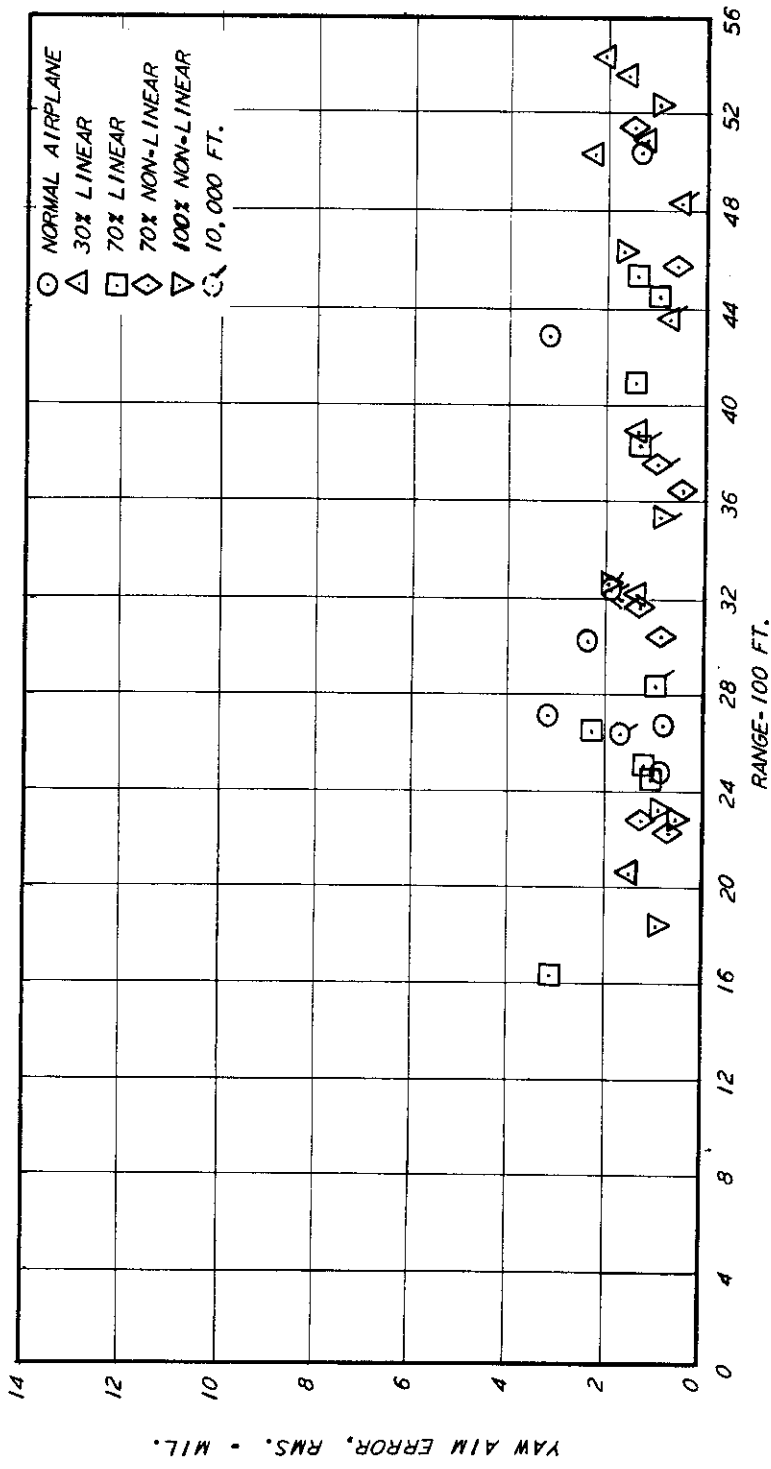

Fig. 19 AIM ERROR IN STRAIGHT STERN CHASE
25,000 FT.
YAW AIM ERROR vs RANGE-PILOT A
DATA FROM STRAIGHT PORTION OF MANEUVER

Continued

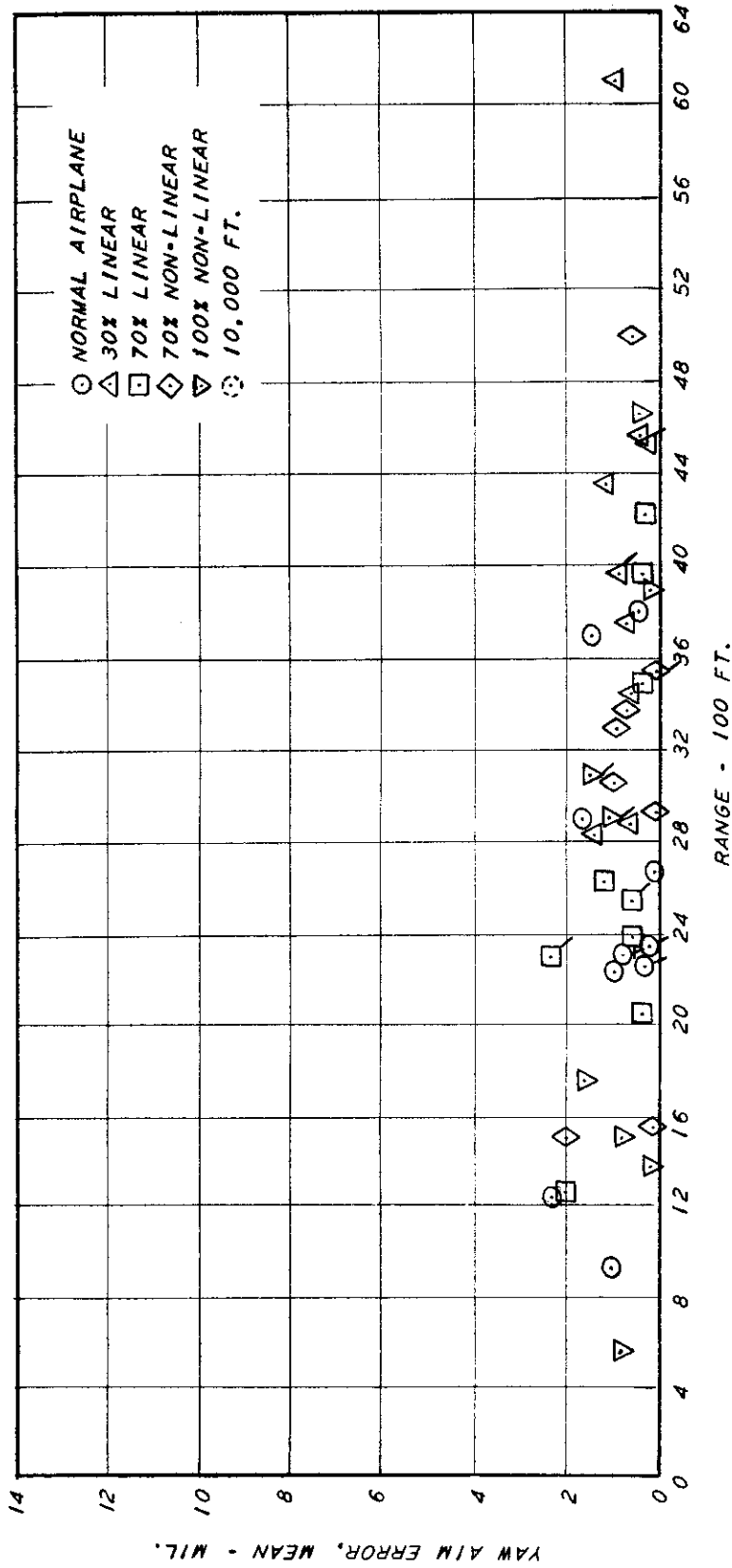

Fig. 20 MEAN AIM ERROR VS. RANGE. - PILOT A

25,000 FT.

DATA FROM TURN PORTION OF MANEUVER

Continued

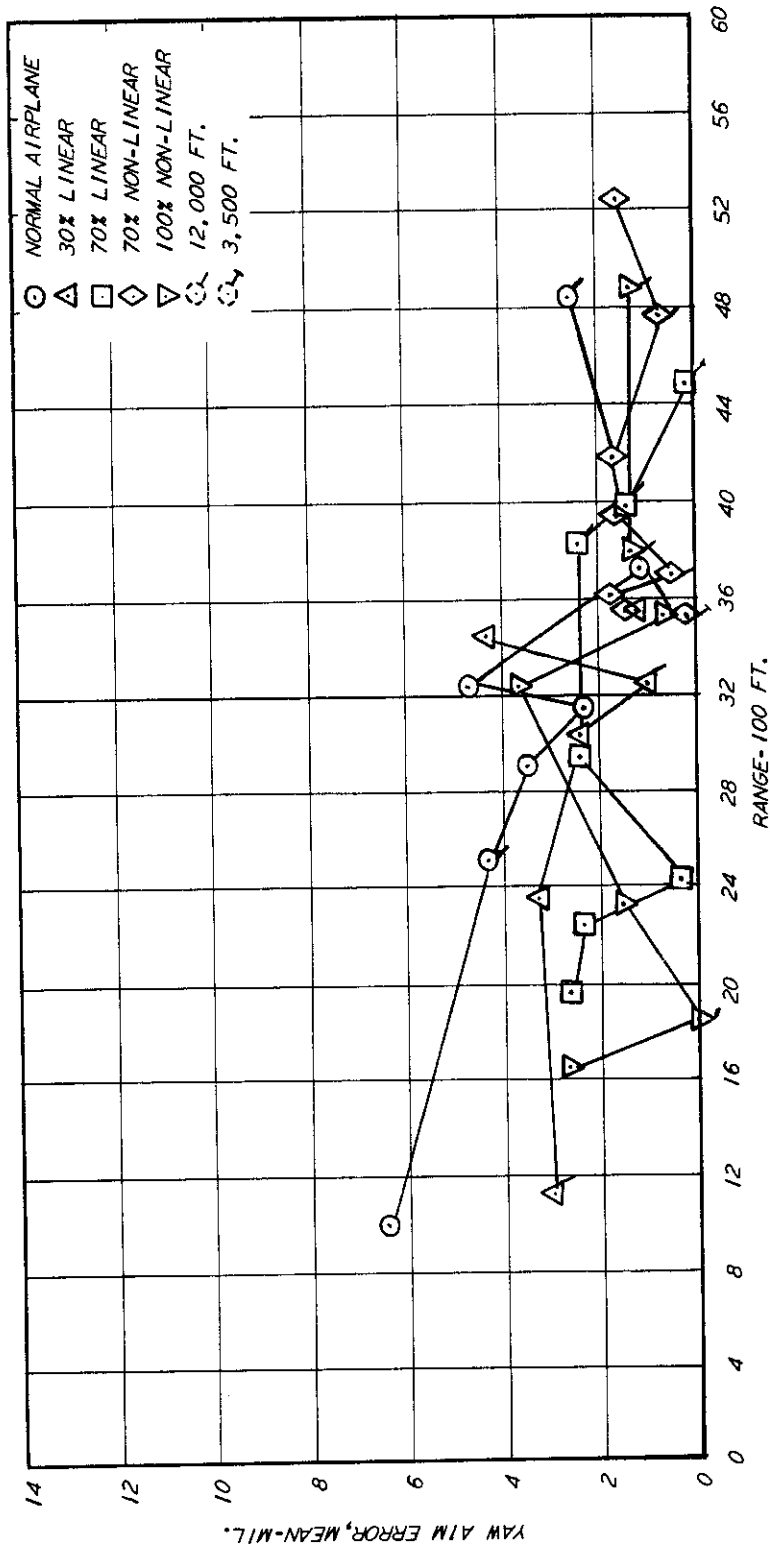

Fig. 21 MEAN AIM ERROR VS RANGE-PILOT B

25,000 FT.

DATA FROM TURN PORTION OF MANEUVER

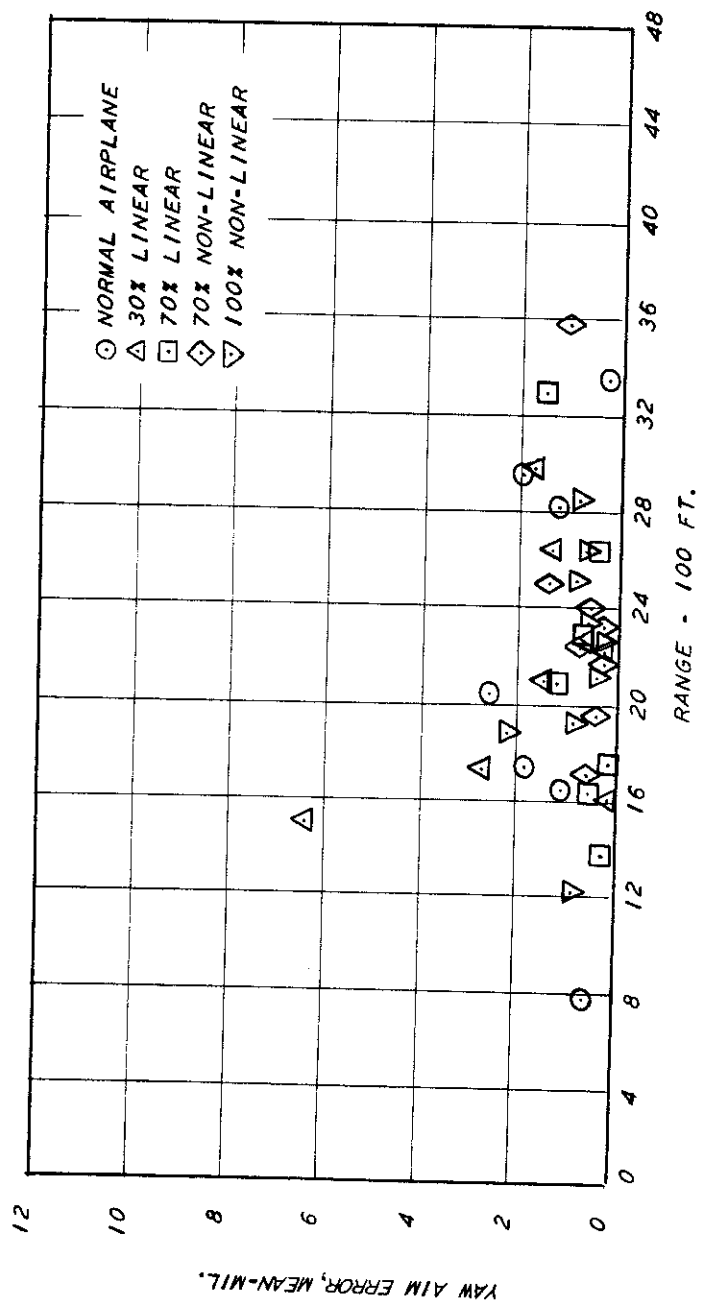

Fig. 22 MEAN AIM ERROR VS. RANGE. - PILOT C
25,000 FT.
DATA FROM TURN PORTION OF MANEUVER

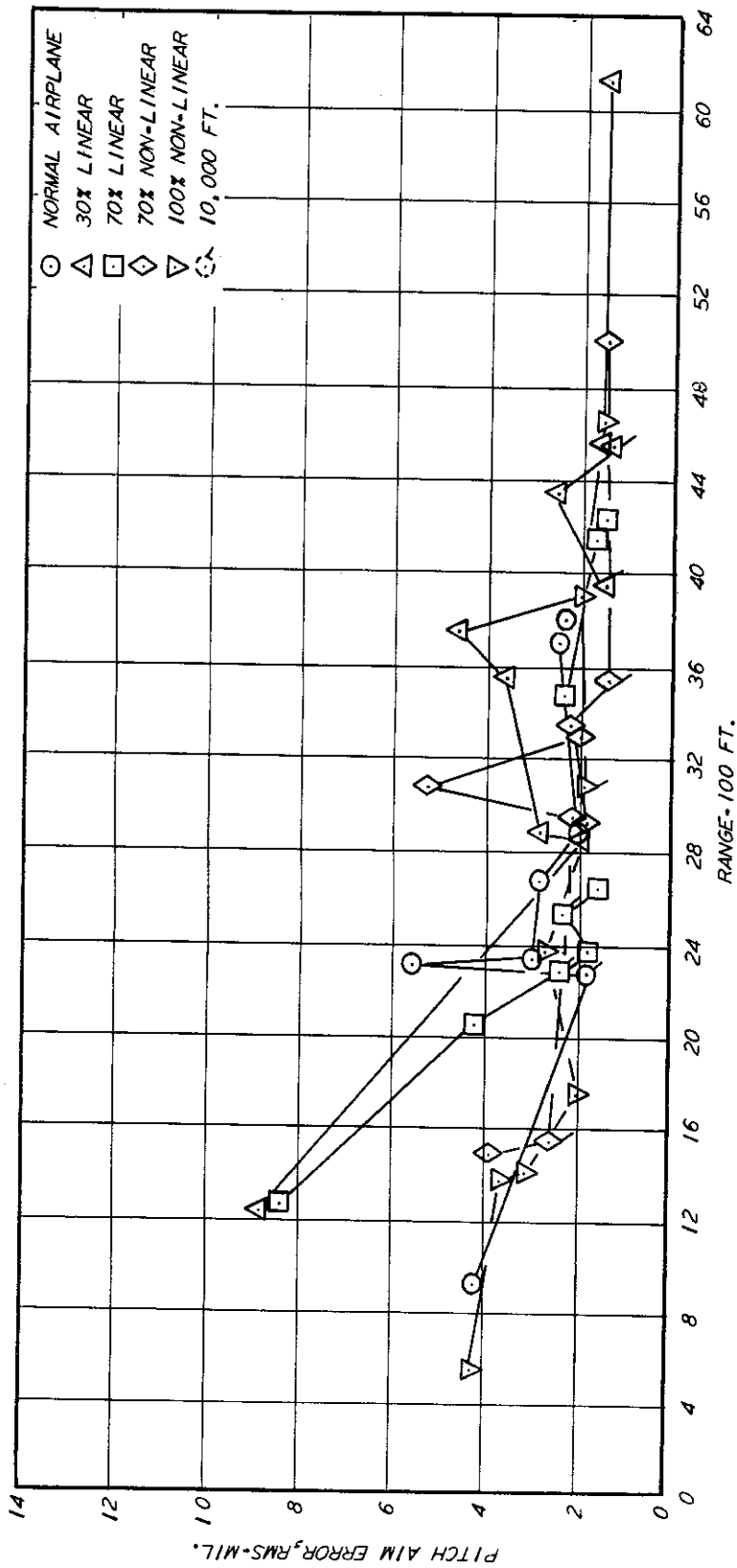

Fig. 23 PITCH AIM ERROR VS RANGE-PILOT A

25,000 FT.

DATA FROM TURN PORTION OF MANEUVER

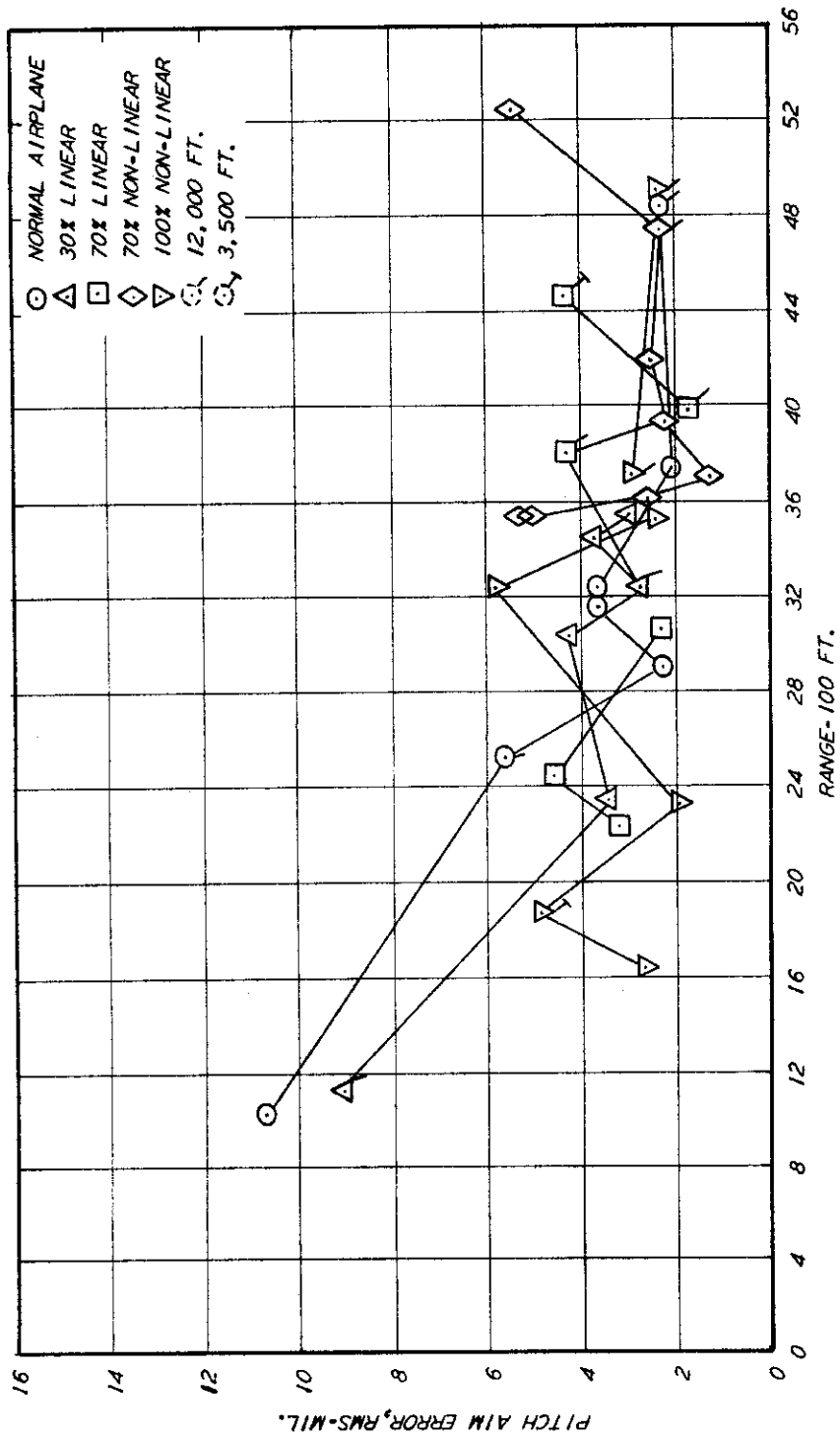

Fig. 24 PITCH AIM ERROR vs RANGE-PILOT B
25,000 FT.
DATA FROM TURN PORTION OF MANEUVER

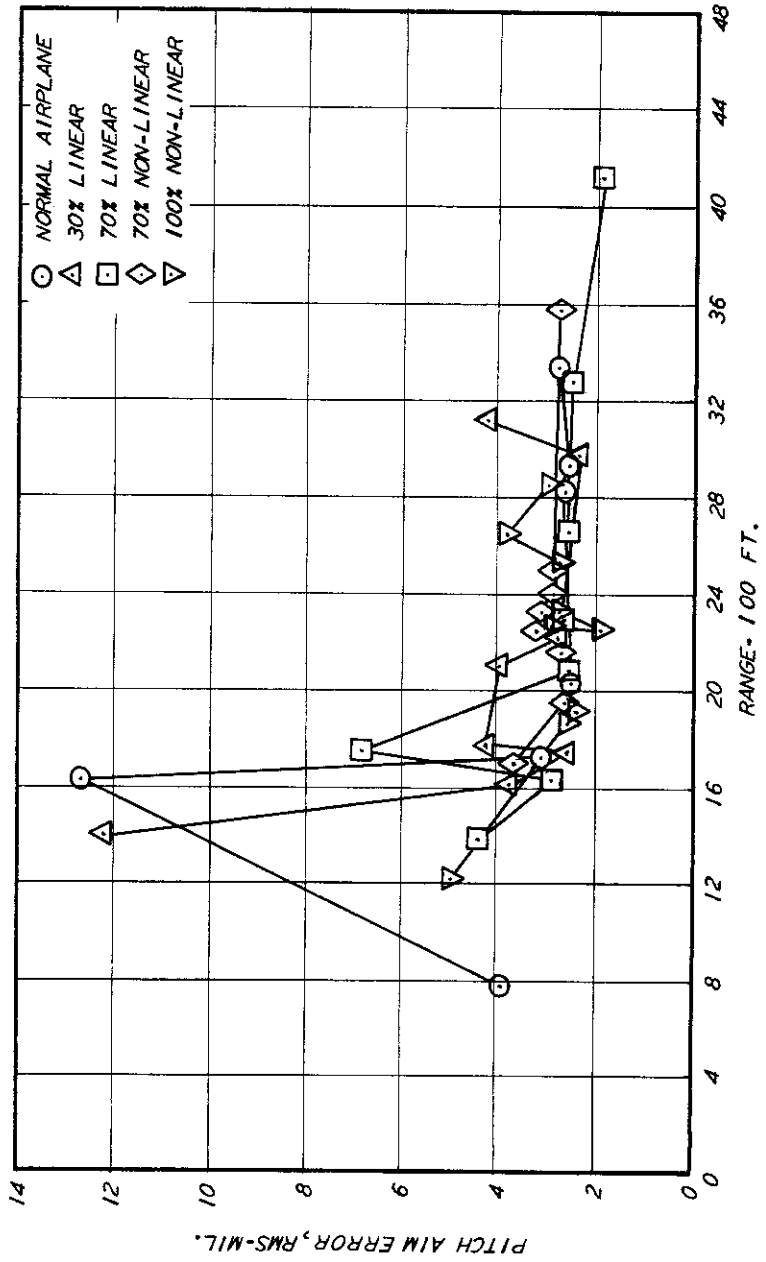

Fig. 25 PITCH AIM ERROR VS RANGE-PILOT C
25,000 FT.
DATA FROM TURN PORTION OF MANEUVER

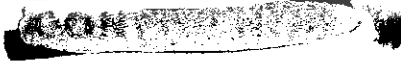

TABLE I

SUMMARY OF EXPERIENCE OF PILOTS

PILOT	A	B	C
TOTAL TIME	2200	3500	1300
FIGHTER TIME	1800	3000	1200
INSTRUMENT TIME	130	400	75
FLIGHT TEST TIME	400	500	150
TRACKING EXPERIENCE (missions)	150	100	50
ENGINEERING EDUCATION	NONE	USAF TEST PILOT TRAINING SCHOOL	U. S. NAVAL ACADEMY (ELECTRICAL ENGINEERING)



Continents

TABLE II
DATA SUMMARY TRACKING ERRORS
PILOT A

YAW	ST	MEAN	RMS	MEAN	RMS	MEAN	RMS	MEAN	RMS	MEAN	RMS	MEAN	RMS	MEAN	RMS	MEAN	RMS
NORMAL	TURN	1.00	6.00	.97	2.95	2.27	.89	.90	2.43	-.22	1.99	-1.27	1.73	.56	.93	.37	1.44
	PITCH			.97	1.51	1.55	2.38	-.04	2.98	.18	4.7	-.30	5.21	-.43	2.56	-.42	3.15
	TURN	1.69	4.10	.15	2.99	1.25	2.00	.67	2.86	0	3.02	-.28	1.79	.93	5.53	-.12	2.42
	FLT-RUN	40-1		41-1		43-2		44-2		45-2		45-10		52-2		52-10	
30% LINEAR	TURN	2.22	8.13	-.62	2.24	-.40	.65	.11	.90	.22	1.40	-.12	2.33	.46	2.10	.16	1.24
	PITCH			-.50	.88	-.20	.91	-.17	1.18	.71	1.17	.15	1.41	-.21	1.17	.70	1.87
	TURN	-2.67	8.88	-.26	3.57	-.03	1.29	.51	1.43	1.74	2.79	-.35	1.66	-.51	1.56	-.19	1.94
	FLT-RUN	43-9		44-1		45-1		45-9		52-1		52-9		53-1		53-7	
70% LINEAR	TURN	1.51	3.11	-.40	1.06	.59	1.23	-.53	1.29	-.82	1.02	-.07	2.27	.11	.99	-.11	1.44
	PITCH			-.98	3.41	-.49	2.90	-.23	1.70	-.53	3.56	1.24	2.34	.25	1.65	.29	2.08
	TURN	4.90	6.35	-.07	4.21	.75	1.71	.33	2.33	1.08	2.32	-.10	1.58	-.04	1.46	.06	1.37
	FLT-RUN	43-1		43-7		44-5		45-3		45-6		52-3		52-6		53-3	
70% NON-LINEAR	TURN	1.26	.93	.12	.74	-.60	1.29	.01	1.01	.10	1.37	.23	1.56	-.46	.71	.96	.56
	PITCH			-.54	1.18	.30	1.25	-.06	1.01	.29	1.32	-.43	.58	.97	1.17	-.29	.73
	TURN	-1.94	2.07	2.53	3.89	-.09	2.61	.46	1.35	-.61	5.18	-.13	1.51	-.49	1.96	-.99	2.19
	FLT-RUN	43-10		44-4		45-4		45-6		52-4		52-8		53-4		53-8	
100% NON-LINEAR	TURN	.85	5.7	1.62	2.43	1.14	.90	-.49	.68	.53	.96	-1.15	2.02	-1.50	.93	.68	1.74
	PITCH			-.22	1.03	-.22	1.03	-.22	1.03	-.22	1.03	-.22	1.03	-.22	1.03	-.22	1.03
	TURN	2.30	4.12	1.63	2.00	-.61	3.61	-.82	2.71	1.06	3.05	1.54	1.91	.04	1.90	-.15	2.01
	FLT-RUN	40-3		41-3		43-5		43-8		44-3		45-5		45-7		52-5	

Contrails

**TABLE III
DATA SUMMARY TRACKING ERRORS - PILOT B**

	MEAN	RMS	MEAN	RMS	MEAN	RMS	MEAN	RMS	MEAN	RMS	MEAN	RMS	MEAN	RMS	MEAN	RMS	
NORMAL	YAW	.34	1.95	.84	1.15	.88	4.88	3.91									
	PITCH	-6.4	14.4	4.78	8.51	-4.21	6.56	5.44	-3.48	5.28	2.20	7.43	-1.09	3.46			
	ST	.68	1.12	.29	1.05	-.55	2.29	2.47									
	TURN	1.49	10.7	.65	3.74	-.59	5.69	2.27	-.17	2.30	-.32	3.71	.74	2.09			
30% LINEAR	YAW	55.2	25000	55.10	12000	57.2	12000	4390.5260.4390	61.1	25000	61.4	25000	61.10	25000			
	PITCH	1510.1150.865	2820.3160.3320	3690.3350.1670	4390.5260.4390	2820.3160.3320	3690.3350.1670	4390.5260.4390	2820.3160.3320	3690.3350.1670	4390.5260.4390	2820.3160.3320	3690.3350.1670	4390.5260.4390	2820.3160.3320	3690.3350.1670	4390.5260.4390
	ST	1.42	1.33	.96	2.40	1.45	2.98	2.53	.005	1.63	.50	4.59					
	TURN	3.23	5.53	-4.28	3.59	-3.00	15.05	4.03	-2.39	4.00	1.13	5.24					
70% LINEAR	YAW	.54	1.61	.57	2.69	.42	2.07	1.48	.86	1.06	.11	5.39	2.29	2.52			
	PITCH	2.29	2.82	-.25	5.02	-2.38	4.27	2.45	-2.79	4.38							
	ST	.01	1.51	-.003	1.09	-.33	.81	1.13	.21	1.35							
	TURN	.85	3.17	.41	4.67	.60	4.32	1.85	1.12	5.61	-2.20	4.47	.09	2.32			
70% NON-LINEAR	YAW	55.3	25000	55.6	12000	57.3	12000	57.6	60.3	25000	60.6	3500	61.2	25000			
	PITCH	2440.2380.2140	2600.2580.2260	5800.5060.2550	4110.4650.3320	1620.1740.2200	1620.1740.2200	4110.4650.3320	1620.1740.2200	4110.4650.3320	1620.1740.2200	4110.4650.3320	1620.1740.2200	4110.4650.3320	1620.1740.2200	4110.4650.3320	1620.1740.2200
	ST	1.29	.86	.17	2.44	.44	1.06	2.33	.35	1.44	-.38	3.99	1.73	3.29	1.56	3.09	
	TURN	-1.41	5.11	-1.76	3.18	.73	4.31	1.88	-1.65	8.28	-.17	5.73					
100% NON-LINEAR	YAW	.06	1.38	-.33	1.08	-.41	.79	1.69	-.78	.91	.34	2.86	-.42	2.58			
	PITCH	1.03	5.35	-1.45	2.73	-1.10	2.46	1.28	.98	5.66	-.74	5.24					
	ST	55.4	25000	55.8	12000	57.4	12000	57.8	60.4	25000	60.8	3500	61.3	25000	61.6	25000	
	TURN	4340.4200.2880	4300.4340.2860	5270.5720.3830	3260.3760.3620	5990.6810.3650	5990.6810.3650	3260.3760.3620	5990.6810.3650	3260.3760.3620	5990.6810.3650	3260.3760.3620	5990.6810.3650	3260.3760.3620	5990.6810.3650	3260.3760.3620	5990.6810.3650
100% NON-LINEAR	YAW	.84	2.39	.48	2.24	.48	1.56	1.87	.02	9.23	-1.49	2.67	-.59	3.28			
	PITCH	3.67	5.75	1.18	3.96	1.31	3.88	4.52	2.72	4.52							
	ST	.23	1.23	-.11	1.95	-.71	.97	.94	-.06	.94							
	TURN	-.46	5.91	.75	2.99	-1.19	2.47	2.71	-.21	2.71	-1.03	2.06	1.04	2.54			
100% NON-LINEAR	YAW	55.7	25000	57.5	12000	57.7	12000	60.5	60.7	25000	61.5	25000	61.9	25000			
	PITCH	3370.3430.3020	5900.4490.2920	7190.6480.3260	2450.1880.1390	2450.1880.1390	2450.1880.1390	2450.1880.1390	2450.1880.1390	2450.1880.1390	2450.1880.1390	2450.1880.1390	2450.1880.1390	2450.1880.1390	2450.1880.1390	2450.1880.1390	2450.1880.1390
	ST	1.42	1.33	.96	2.40	1.45	2.98	2.53	.005	1.63	.50	4.59					
	TURN	3.23	5.53	-4.28	3.59	-3.00	15.05	4.03	-2.39	4.00	1.13	5.24					

**TABLE IV
DATA SUMMARY TRACKING ERRORS - PILOT C**

	MEAN	RMS	MEAN	RMS	MEAN	RMS	MEAN	RMS	MEAN	RMS	MEAN	RMS	MEAN	RMS	MEAN	RMS	MEAN	RMS
NORMAL	ST	2.26	3.34	-1.88	5.64	-1.16	4.35	-2.00	4.53	.22	4.39							
	TURN	1.08	19.78	.57	14.65	-2.64	6.71	-1.88	5.64	-1.16	4.35	-2.00	4.53	.22	4.39			
	ST	1.58	1.25	1.42	3.92	-.67	2.47	-.35	3.05	-1.01	2.53	.47	2.71					
	TURN	10.24	12.29	1.42	3.92	-.67	2.47	-.35	3.05	-1.01	2.53	.47	2.71					
	FLT-RUN ALT RANGE	56.2 25000 1570-1420-1880	62.1 25000 -800-770	62.1 25000 -3060-1030	63.2 25000 -2020-1470	63.8 25000 -3370-2260	64.2 25000 -3400-2510	64.11 25000 -3990-2740	64.11 25000 -3990-2740	64.2 25000 -3400-2510	64.2 25000 -3400-2510	64.2 25000 -3400-2510	64.11 25000 -3990-2740	64.11 25000 -3990-2740	64.11 25000 -3990-2740	64.11 25000 -3990-2740	64.11 25000 -3990-2740	64.11 25000 -3990-2740
30% LINEAR	ST	-.98	1.70	-.50	1.95	.14	2.74	1.30	2.71	1.86	1.85	1.47	3.54					
	TURN	6.37	19.65	2.80	3.97	-.57	2.54	.07	4.89	.14	2.74	1.30	2.71	1.86	1.85	1.47	3.54	
	ST	1.75	1.17	3.59	2.84	1.08	4.13	-.94	2.40	64.1	25000	25000	25000	-2180-2020				
	TURN	11.53	12.14	1.98	4.16	-1.00	2.66	-.87	3.75	1.08	4.13	-.94	2.40	64.1	25000	25000	25000	25000
	FLT-RUN ALT RANGE	56.1 25000 1830-1690-1315	56.9 25000 2530-2020-1520	62.4 25000 -3200-1330	62.8 25000 -1790-1430	63.3 25000 -2420-2000	63.7 25000 -3950-2290	64.1 25000 -3790-2180	64.1 25000 -3790-2180	63.7 25000 -3950-2290	63.7 25000 -3950-2290	63.7 25000 -3950-2290	64.1 25000 -3790-2180	64.1 25000 -3790-2180	64.1 25000 -3790-2180	64.1 25000 -3790-2180	64.1 25000 -3790-2180	64.1 25000 -3790-2180
70% LINEAR	ST	.78	2.26	.33	2.13	.67	1.60	-.123	2.69	1.59	2.13	-.60	2.19					
	TURN	-.08	4.78	-.32	3.49	.51	3.20	.18	2.68	-.123	2.69	1.59	2.13	-.60	2.19			
	ST	.57	1.11	-.10	1.52	-.107	2.87	-.173	4.33	.82	2.73	-.37	2.60	-.59	1.88			
	TURN	4.51	6.79	.08	2.56	-.107	2.87	-.173	4.33	.82	2.73	-.37	2.60	-.59	1.88			
	FLT-RUN ALT RANGE	56.3 25000 1640-1670-1850	56.6 25000 3110-2940-2350	62.2 25000 -1760-1480	62.7 25000 -1740-1040	63.5 25000 -2770-1810	63.10 25000 -2180-1970	64.3 25000 -3870-2670	64.3 25000 -3870-2670	63.10 25000 -2180-1970	63.10 25000 -2180-1970	63.10 25000 -2180-1970	64.3 25000 -3870-2670	64.3 25000 -3870-2670	64.3 25000 -3870-2670	64.3 25000 -3870-2670	64.3 25000 -3870-2670	64.3 25000 -3870-2670
70% NON-LINEAR	ST	-.84	.60	2.69	.93	-.19	3.64	.12	4.03	-1.45	2.68	.54	3.42	-1.04	2.66	.74	2.24	
	TURN	.55	5.34	.37	3.14	-.19	3.64	.12	4.03	-1.45	2.68	.54	3.42	-1.04	2.66	.74	2.24	
	ST	.18	1.28	.82	1.30	-.47	3.06	-.33	2.77	.24	2.78	.44	2.84	-.90	2.81	.07	3.19	
	TURN	2.10	3.73	.76	2.69	-.47	3.06	-.33	2.77	.24	2.78	.44	2.84	-.90	2.81	.07	3.19	
	FLT-RUN ALT RANGE	56.4 25000 2190-1860-1540	56.8 25000 2190-1990-1950	62.3 25000 -3040-1580	62.6 25000 -3170-1170	63.4 25000 -2920-2050	63.9 25000 -2810-1990	64.4 25000 -4120-3040	64.4 25000 -4120-3040	63.9 25000 -2810-1990	63.9 25000 -2810-1990	63.9 25000 -2810-1990	64.4 25000 -4120-3040	64.4 25000 -4120-3040	64.4 25000 -4120-3040	64.4 25000 -4120-3040	64.4 25000 -4120-3040	64.4 25000 -4120-3040
100% NON-LINEAR	ST	2.09	1.66	.29	1.89	-.88	2.63	-.87	2.27	.30	2.70	-.62	2.37	-.26	3.00			
	TURN	-.88	8.68	.77	2.78	.91	2.57	-2.21	2.23	-.88	2.63	-.87	2.27	.30	2.70	-.62	2.37	
	ST	-.43	1.35	-.65	1.37	-1.44	2.71	-1.05	2.55	-1.19	2.42	.02	2.95	.38	2.81	-.52	2.74	.32
	TURN	1.00	4.95	1.10	3.87	-1.44	2.71	-1.05	2.55	-1.19	2.42	.02	2.95	.38	2.81	-.52	2.74	.32
	FLT-RUN ALT RANGE	56.5 25000 1790-1420-1000	56.7 25000 3690-3260-2020	62.5 25000 -3600-1420	62.9 25000 -1630-2120	63.1 25000 -1930-1900	63.6 25000 -3560-2140	64.5 25000 -2750-1500	64.5 25000 -2750-1500	63.6 25000 -3560-2140	63.6 25000 -3560-2140	63.6 25000 -3560-2140	64.5 25000 -2750-1500	64.5 25000 -2750-1500	64.5 25000 -2750-1500	64.5 25000 -2750-1500	64.5 25000 -2750-1500	64.5 25000 -2750-1500

TABLE V
PILOT COMMENTS - PILOT A

SETTING					
NORMAL KNOWN	49-1 OSC. NOTICEABLE BUT SLIGHT. PROMPT RESPONSE TO RUDDER PEDAL. <u>ACCEPTABLE +</u>	49-3 QUITE A BIT OF YAW OSC. <u>ACCEPTABLE</u>	48-1 OSC. NOTICEABLE BUT CONTROLLABLE. HARD TO STOP OSC. ON TARGET. GOOD RESPONSE TO RUDDER. <u>ACCEPTABLE GOOD. -</u>		
NORMAL NOT KNOWN	53-2 YAW OSC. NOTICEABLE BUT CONTROLLABLE. NOT STIFF ENOUGH, OVERSHOTS. RUDDER FORCES GOOD, LIGHTER THAN NORMAL	52-2 NOT STIFF ENOUGH IN YAW. RUDDER FORCES ABOUT RIGHT. TURN ENTRY BELOW AVERAGE. <u>ACCEPTABLE</u>	52-10 OSC. EXCESSIVE. NOT STIFF IN YAW. RESPONSE (FORCE?) A LITTLE HEAVY. <u>UNACCEPTABLE +</u>	44-2 FAIRLY STIFF IN YAW. EASY TO MOVE NOSE TO NEW POSITION BUT TOO MUCH OVERSHOOT.	44-9 VERY POOR. TOO MUCH OVERSHOOT.
NORMAL SIMULATED	49-6 OSC. OBJECTIONABLE. FORCES GOOD. <u>UNACCEPTABLE</u>				
30% LINEAR	53-1 YAWING OSC. NOT NOTICEABLE, BUT NOT STIFF ENOUGH. RUDDER FORCES GOOD. <u>ACCEPTABLE GOOD</u>	53-7 YAW OSC. NOT NOTICEABLE, STIFF IN YAW. RUDDER FORCES GOOD. MAYBE LIGHT, TRIED TO GIVE TOO MUCH RUDDER. <u>ACCEPTABLE GOOD +</u>	53-9 OSC. NOTICEABLE CONTROLLABLE. NOT STIFF ENOUGH. RUDDER FORCES GOOD. <u>ACCEPTABLE GOOD</u>	53-10 OSC. NOT NOTICEABLE. FORCES GOOD, STIFF IN YAW. <u>ACCEPTABLE GOOD +</u>	52-1 NOT STIFF ENOUGH IN YAW. <u>ACCEPTABLE +</u>
70% LINEAR	53-3 YAW NOTICEABLE BUT CONTROLLABLE. RUDDER FORCES LIGHT AIRPLANE STIFF IN YAW. <u>ACCEPTABLE GOOD -</u>	53-5 YAW OSC. NOTICEABLE BUT CONTROLLABLE. RUDDER FORCE GOOD. NOT STIFF ENOUGH. <u>ACCEPTABLE GOOD</u>	52-3 OSC. NOT NOTICEABLE. STIFF IN YAW. RUDDER FORCES VERY GOOD. <u>OPTIMUM</u>	52-6 OSC. NOT NOTICEABLE. STIFF IN YAW, FORCES GOOD. ENTRY GOOD. <u>OPTIMUM</u>	49-2 OSC. NOT NOTICEABLE. RESPONSE SLIGHTLY SLUGGISH. FORCES A LITTLE HIGH. <u>ACCEPTABLE GOOD</u>
70% NON-LINEAR	✓ 53-4 YAW OSC. NOT NOTICEABLE. RUDDER FORCES GOOD. <u>ACCEPTABLE GOOD +</u>	✓ 53-6 AS (53-4) & STIFF IN YAW. <u>ACCEPTABLE GOOD</u>	✓ 53-8 YAW OSC. NOTICEABLE, WELL CONTROLLED. FORCES GOOD. NOT STIFF ENOUGH. <u>ACCEPTABLE GOOD</u>	⊗ 52-4 OSC. NOTICEABLE. NOT STIFF ENOUGH, FORCES TOO LIGHT. <u>ACCEPTABLE -</u>	✓ 52-8 OSC. NOTICEABLE; NOT STIFF ENOUGH, RESPONSE TOO ABRUPT, FORCES GOOD. <u>ACCEPTABLE +</u>
100% NON-LINEAR	✗ 52-5 OSC. NOT NOTICEABLE, STIFF IN YAW. FORCES GOOD, ENTRY, RECOVERY NOT TOO GOOD. <u>ACCEPTABLE GOOD</u>	✓ 52-7 OSC. NOT NOTICEABLE. RUDDER RESPONSE DELAYED, FORCES GOOD. TRACKING GOOD BUT DID NOT FEEL AS GOOD AS 52-6 (70% LINEAR). <u>ACCEPTABLE GOOD</u>	✓ 49-3 OSC. NOT NOTICEABLE, MUCH LESS THAN NORMAL AIRPLANE. RESPONSE SLUGGISH, FORCES HIGH. <u>ACCEPTABLE</u>	44-3 WELL DAMPED PROMPT RESPONSE.	✗ 45-5 VERY GOOD ON TARGET, RUDDER FORCES TOO HIGH.

53. AT 10,000 FT. COULD NOTICE DIFFERENCE BETWEEN LINEAR AND NON-LINEAR; AT 25,000 FT. COULD NOT. NON-LINEAR HAS FAST RESPONSE NO OVERSHOOT, LINEAR SLOW RESPONSE NO OVERSHOOT.

48. SERVOS OFF, GET A VERY GOOD OSC. SERVOS ON (70% LINEAR) GET NONE AT ALL.



TABLE V (contd.)
PILOT COMMENTS - PILOT A

LEGEND

_____ Rated on Qualitative flight (no target)

⊗ Did not become non-linear

X Became non-linear only slightly

✓ No oscillograph record. Could not tell whether became non-linear.

64-4 Identifies Flight 64, Run 4

45-2 UNSATISFACTORY	45-10 QUITE A BIT OF YAW REQUIRES CONSTANT CORRECTION. HARD TO STAY ON TARGET. FEELS LIKE NORMAL AIRPLANE.				
52-9 OSC. VERY NOTICEABLE, NOT STIFF. FORCES GOOD, RESPONSE GOOD BUT TOO MUCH.	49-5 OSC. NOT NOTICEABLE. RESPONSE TO RUDDER IS GOOD.	43-9 BAD RESPONSE GOOD BUT TOO MUCH OVERSHOOT.	43-3 LIKE (THIS SETTING) VERY MUCH.	45-9 GOOD AS LONG AS NOT DISTURBED.	
ACCEPTABLE -	ACCEPTABLE GOOD				
48-2 OSC. FORCES GOOD.	43-7	44-5 PROMPT RESPONSE, NO OVERSHOOT. THE BEST. (PRECEDED BY 70% NON-LINEAR).	44-6 VERY GOOD. SAME COMMENTS AS RUN 44-5, SAME SETTING.	45-7 RUDDER FORCES A LITTLE HIGH.	
	EXCELLENT				
✓ 49-4 OSC. NOT NOTICEABLE. RESPONSE TO PEDAL IS PROMPT.	43-6 BETTER THAN 43-5, (100% NON-LINEAR).	✓ 43-10 RESPONSE GOOD. TENDENCY TO OVERCONTROL.	X 44-4 WELL DAMPED PROMPT RESPONSE. LITTLE BIT OF OVERSHOOT.	X 45-4 WELL DAMPED. FORCES A LITTLE HIGH.	X 45-8 BEST (CONFIG.) TODAY. HOLDS TARGET STEADILY.
ACCEPTABLE +					
X 45-7 VERY EASY TO TRACK. RUDDER FORCES A LITTLE HIGH.					

~~CONFIDENTIAL~~

TABLE VI
PILOT COMMENTS - PILOT B

SETTING			
NORMAL KNOWN	61-1 LOT MORE DIFFICULT TO STAY ON TARGET (THAN 70% LINEAR)		
NORMAL NOT KNOWN	57-10 DIFFICULTY GETTING DAMPED AND STAYING ON TARGET IN TURN.	61-4 BETTER THAN 61-3 (70% NON-LINEAR), BUT NOTICES OSCILLATION.	61-8 TROUBLE STAYING ON TRIM, RUDDER SEEMED SO LIGHT I WAS YAWING BACK AND FORTH.
NORMAL SIMULATED			
30% LINEAR	57-9 PRETTY GOOD.	59-4 VERY SLIGHT YAWING.	59-5 RUDDER FORCES STRONGER THAN (SAME SETTING. (59-4)).
70% LINEAR	59-1 PRETTY GOOD, WELL DAMPED, STAYS RIGHT ON TARGET. RUDDER FORCES EXTREMELY LIGHT.	60-3 RESPONSE TO RUDDER VERY GOOD.	61-2 VERY GOOD. MUCH BETTER THAN NORMAL (61-1). RUDDER FORCES GOOD.
70% NON- LINEAR	✓ 57-4 BEST SO FAR (30 AND 70% LINEAR AND NORMAL PRECEDED THIS RUN.)	✓ 57-8 BEST SO FAR. (30, 70% LINEAR, 100% NON-LINEAR AND NORMAL PRECEDED THIS RUN.)	59-2 DAMPING VERY GOOD. RUDDER FORCES LITTLE HIGHER (THAN 59-1 (70% LINEAR)).
100% NON- LINEAR	✓ 57-7 PRETTY GOOD.	59-3 FEELS PRETTY GOOD. RUDDER FORCES A LITTLE HEAVIER. DAMPING NOT AS FAST (AS 70%) (?). OVERSHOTS A LITTLE.	60-5 HOLDING TARGET SEEMED SIMPLE.
	57- LIKE 70% NON-LINEAR BEST. 100% NON-LINEAR NOT MUCH DIFFERENT FROM 70% NON-LINEAR. LIKED NON-LINEAR BETTER THAN LINEAR. EASIER TO MOVE TO NEW POSITION.		



TABLE VI (contd.)
PILOT COMMENTS - PILOT B

		LEGEND	
		————— Rated on Qualitative flight (no target)	
		X	Did not become non-linear.
		X	Became non-linear only slightly
		✓	No oscillograph. Could not tell whether became non-linear.
		61-4	Identifies Flight 61, Run 4
61-10 LOUSY. HARD TO DAMP YAW ON TARGET. DIFFICULT TO GET BACK ON TRIM.		61-12 NOT SO GOOD. QUITE A BIT OF YAW. BACK AND FORTH THROUGH TARGET AT GOOD RATE.	
60-1 YO-YO BACK AND FORTH, TROUBLE KEEPING IT ON TARGET.			
61-7 VERY GOOD. FELT JUST FINE.		61-11 VERY GOOD.	
✓ 60-4 FELT VERY GOOD.	X 60-8 NOT TOO BAD. WHEN OFF TARGET, HARD TO PUT BACK ON. (HAD TO MOVE ENTIRE AIRPLANE, NOT JUST NOSE.	61-3 NOTICED OSCILLATION STAYING ON TARGET. ALL OVER SKY.	61-6 NOT AS GOOD AS 61-5 (100% NON-LINEAR). RUD- DER FORCES GOOD. SLIPPING AND SLIDING BIT MORE THAN USUAL.
60-7 DAMPING NOT VERY EFFECTIVE. OSCILLATED THROUGH TARGET. (ROUGH AIR SHORT RANGE)	61-5 VERY GOOD.	61-9 NOT SO GOOD. YO-YO. OVERSHOOTING (JET WASH)	
59- COMPARISON OF LINEAR AND NON-LINEAR 70%: (NON-LINEAR) SEEMS MORE DEFINITE RESPONSE. CAN'T NOTICE MUCH DIFFERENCE AT LOWER ALTITUDE. BOTH APPEAR SAME AT LOW SPEED (250 MPH).			





TABLE VII
PILOT COMMENTS - PILOT C

SETTING				
NORMAL KNOWN	58-6 MUST FIGHT RUD- DER ALL THE TIME.	62-1 LOT OF OVERSHOOT.		
NORMAL NOT KNOWN	63-8 JUMPIER. HARD TO SETTLE DOWN IN YAW. RUDDER FORCES VERY LIGHT.	64-2 SLOPPIER THAN 64-1 (30% LINEAR). RUDDER FORCES GOOD, HARD TO CONTROL HEAD- ING.	64-10 WORSE THAN (ANY ADDED DAMPING). QUITE A BIT HARDER TO HOLD ON TARGET. VERY TOUCHY. VERY LOOSE.	62-10 MORE JUMPY. HARDER TO CONTROL (THAN ANY DAMPED CON- FIG.).
NORMAL SIMULATED				
30% LINEAR	56-9 UNDER DAMPED QUITE A BIT OF OSCIL- LATION.	58-1 QUITE GOOD. SOME OSCILLATION.	62-4 GOOD BUT LITTLE HARDER TO HOLD. LITTLE JUMPY IN YAW. RUDDER FORCES NICE AND LIGHT.	62-8 HARDER TO SETTLE DOWN. NOTICEABLY MORE JUMPY THAN 62-7 (70%)
70% LINEAR	58-6 NOT AS GOOD AS 56-5 (100% NON-LINEAR).	58-3 ACCEPTABLE-GOOD. OSCILLATION BETTER THAN 58-1 (30%).	62-2 VERY GOOD. DAMPED REAL FINE.	62-7 GOOD. FORCES GOOD, DAMPING EXCEL- ENT.
70% NON-LINEAR	X 56-4 GOOD	X 56-8 PARTICULARLY GOOD. DEADBEAT. EASY TO CONTROL.	X 58-4 WELL DAMPED RUDDER FORCES BETTER THAN 58-3 (70% LINEAR). DAMPING SAME.	62-3 DAMPING GOOD, EASY TO HOLD TARGET. RUDDER FORCES SLIGHTLY HIGHER.
100% NON-LINEAR	X 56-5 GOOD. SAME AS 56-4. (70% NON-LINEAR)	58-5 VERY WELL DAMPED. LIKE 58-4 (70% NON- LINEAR).	X 62-5 QUITE GOOD. VERY STEADY.	62-9 DAMPING EXCELLENT, FORCES LITTLE HIGH.

56. LIKED 70%. LIKES NON-LINEAR. NOT A STRONG
BENEFIT, BUT NICE (56).

58. NEGLIG. DIFFERENCE IN DAMPING BETWEEN
LINEAR AND NON-LINEAR. RUDDER FORCES
LIGHTER WITH NON-LINEAR.



TABLE VII (contd.)
PILOT COMMENTS - PILOT C

<p>63-2 QUITE UNSTABLE HARD TO MAINTAIN ON TARGET. (NICE) LIGHT RUDDER FORCES.</p>	<p style="text-align: center;">LEGEND</p> <p>————— Rated on Qualitative Flight (No target to track).</p> <p>X Did not become non-linear.</p> <p>X Became non-linear only slightly.</p> <p>✓ No oscillograph; could not tell whether became non-linear.</p> <p>61-4 Identifies Flight 61, Run 4</p>			
<p>63-3 HARD TO HOLD ON TRACK. SLIGHTLY UN- STABLE IN YAW. RUDDER FORCES VERY LIGHT.</p>	<p>63-7 SLIGHTLY JUMPY BUT EASILY CONTROLLED. RUDDER LIGHT.</p>	<p>64-1 VERY GOOD. QUITE STEADY. LIGHT RUD- DER FORCES.</p>	<p>64-9 NOTICEABLY MORE DIFFICULT THAN (70 OR 100% DAMPING). TOUCHY RUDDER.</p>	
<p>63-5 STEADY, EASY TO HOLD ON TARGET. RUD- DER FORCES GOOD.</p>	<p>63-10 QUITE STEADY. SETTLED DOWN QUITE WELL. LIKE 63-9 (70% NON-LINEAR).</p>	<p>64-3 QUITE GOOD. RUD- DER FORCES SLIGHTLY HEAVY. VERY STEADY.</p>	<p>64-6 QUITE STEADY. THIS AND 64-3 (ALSO 70% LINEAR). RATED BEST</p>	
<p>X 62-6 VERY GOOD. QUITE STEADY, EASY TO HOLD ON TARGET.</p>	<p>✓ 63-4 STEADY, EASY TO HANDLE.</p>	<p>✓ 63-9 QUITE STEADY, SETTLED DOWN QUITE WELL.</p>	<p>✓ 64-4 EXACTLY AS 64-3 (70% LINEAR)</p>	<p>✓ 64-7 VERY GOOD. RUDDER FORCES LIGHTER THAN 64-6. (70% LIN- EAR). LIKES THIS BETTER.</p>
<p>✓ 63-1 VERY GOOD. VERY STEADY, FORCES SLIGHTLY HIGH.</p>	<p>✓ 63-6 EASY AND SMOOTH. NO DIFFERENCE FROM 63-5 LINEAR (70%).</p>	<p>✓ 64-5 LIKE 64-3,4 (70% LINEAR AND NON- LINEAR). MAYBE SLIGHTLY STIFFER.</p>	<p>✓ 64-8 VERY GOOD. TRIFLE STIFF BUT STAYED ON TARGET.</p>	

Table A-1
Equations of Motion

$$(1) \quad \dot{\beta} = -C_{y\beta} \frac{1}{\tau} \beta + \frac{C_L}{2\tau} \sin \phi - \frac{\mu_2}{\tau} \frac{rb}{2V} + C_{y\delta_R} \frac{1}{\tau} \delta_R$$

$$(2) \quad \frac{\dot{pb}}{2V} = -C_{l\beta} \frac{1}{i_A \tau} \beta - C_{lp} \frac{1}{i_A \tau} \frac{pb}{2V} + C_{lr} \frac{1}{i_A \tau} \frac{rb}{2V} \\ - \frac{i_E}{i_A} \frac{\dot{rb}}{2V} - C_{l\delta_A} \frac{1}{i_A \tau} \delta_A + C_{l\delta_R} \frac{1}{i_A \tau} \delta_R$$

$$(3) \quad \frac{\dot{rb}}{2V} = C_{n\beta} \frac{1}{i_c \tau} \beta + C_{np} \frac{1}{i_c \tau} \frac{pb}{2V} - \frac{i_E}{i_c} \frac{\dot{pb}}{2V} \\ - C_{nr} \frac{1}{i_c \tau} \frac{rb}{2V} + C_{n\delta_A} \frac{1}{i_c \tau} \delta_A - C_{n\delta_R} \frac{1}{i_c \tau} \delta_R$$

$$(4) \quad \dot{\phi} = \frac{\mu_2}{\tau} \frac{pb}{2V}$$

$$(5a) \quad \delta_D = \frac{\mu_2}{\tau} \frac{\delta_R}{r} e^{-a(ny/q)^4} \left[\frac{rb}{2V} \cos(\alpha_0 - 4^\circ) + \frac{pb}{2V} \sin(\alpha_0 - 4^\circ) \right]$$

$$(5b) \quad \delta_F = \frac{\delta_D}{D + 1/\tau_1} + K_A \delta_A$$

$$(6) \quad \delta_F = K_A \delta_A - \frac{\mu_2}{\tau} \frac{\delta_R}{r} e^{-a(ny/q)^4} \left[\frac{rb}{2V} \cos(\alpha_0 - 4^\circ) - \frac{K}{M^2} \sin \phi \right. \\ \left. + \frac{p\dot{\phi}}{2V} \sin(\alpha_0 - 4^\circ) \right]$$

$$(7) \quad \delta_R = \frac{\omega_n^2}{D^2 + 2\zeta\omega_n + \omega_n^2} \delta_F$$

**Table A-II
List of Symbols**

β - Sideslip angle

r - Yaw rate

p - Roll rate

ϕ - Bank angle

V - True airspeed along flight path

b - Wing span

c - Wing mean aerodynamic chord

C_L - Lift coefficient

m - Mass

ρ - Density of atmosphere

S - Wing area

$$\tau = \frac{m}{\rho S V}$$

W - Weight

$$C_{L\beta} = \frac{dC_L}{d\beta}$$

$$C_{n\beta} = \frac{dC_n}{d\beta}$$

$$C_{y\beta} = \frac{dC_y}{d\beta}$$

$$C_{Lp} = \frac{dC_L}{d(p b / 2V)}$$

$$C_{nr} = \frac{dC_n}{d(r b / 2V)}$$

$$C_{Lr} = \frac{dC_L}{d(r b / 2V)}$$

$$C_{nr} = \frac{dC_n}{d(r b / 2V)}$$

$$C_{L\delta_a} = \frac{dC_L}{d\delta_a}$$

$$C_{y\delta_a} = \frac{dC_y}{d\delta_a}$$

$$C_{n\delta_a} = \frac{dC_n}{d\delta_a}$$

$$C_{L\delta_r} = \frac{dC_L}{d\delta_r}$$



Table A-II (cont'd)

$$C_{y\delta_r} = \frac{dC_y}{d\delta_r}$$

$$C_{n\delta_r} = \frac{dC_n}{d\delta_r}$$

$$\mu_2 = \frac{2m}{\rho S b}$$

$$i_A = \frac{4I_x}{mb^2}$$

$$i_C = \frac{4I_z}{mb^2}$$

$$i_E = \frac{4I_{zz}}{mb^2}$$

I_x - Moment of inertia about principal X axis

I_z - Moment of inertia about principal Z axis

α_0 - Inclination of gyro mounting axis with respect to relative wind axis

q - Dynamic pressure

δ_A - Aileron deflection

δ_R - Rudder deflection

τ_f - Time constant of filter for steady turn yaw alleviation

$K_A \cdot \delta_r / \delta_A$ Gain yaw correction for aileron deflection