

FDL-TDR-64-105

Methods in Structural Dynamics
for
Thin Shell Clustered Launch Vehicles

TECHNICAL DOCUMENTARY REPORT NO. FDL-TDR-64-105

APRIL 1965

J. S. Keith, et al.
LTV Astronautics

AIR FORCE FLIGHT DYNAMICS LABORATORY
RESEARCH AND TECHNOLOGY DIVISION
AIR FORCE SYSTEMS COMMAND
WRIGHT-PATTERSON AIR FORCE BASE, OHIO

FOREWORD

This report covers research conducted by the LTV Astronautics Division, Ling-Temco-Vought, Inc., Dallas, Texas, for the Aerospace Dynamics Branch, Vehicle Dynamics Division, AF Flight Dynamics Laboratory, Wright-Patterson Air Force Base, Ohio, under Contract No. AF33(657)-9146. This work was performed to advance the dynamic loads state of the art for flight vehicles as part of the Research and Technology Division, Air Force Systems Command's exploratory development program. The research was conducted under Project No. 1370, "Dynamic Problems in Flight Vehicles," and Task No. 137008, "Prediction and Prevention of Dynamic Load Problems". Mr. Lynn C. Rogers and later Mr. T. D. Lemley of the Vehicle Dynamics Division, AF Flight Dynamics Laboratory were the project engineers.

The project engineer for LTV Astronautics was Mr. J. Stuart Keith. The principal authors were Mr. J. S. Keith and Mr. J. W. Lincoln; Mrs. Susan P. Shrader was responsible for coding the computer program in Appendix I. Mrs. Shrader was also the author of that part of the report. Mr. J. D. Chaney was responsible for the vibration analysis of the Saturn vehicle and he was the author of Appendix II which describes this analysis.

The cooperation of the NASA at Langley Field, Virginia, is gratefully acknowledged. LTV Astronautics is especially grateful to NASA, Langley for making available a complete set of blueprints for the 1/5 scale model of the Saturn vehicle and in particular for the close cooperation of Mr. Homer Morgan and Mr. John Mixson of the Dynamic Loads Division.

This is the final report on Contract AF33(657)-9146.

This report has been reviewed and is approved.

Walter J. Mykytow
WALTER J. MYKYTOW
Asst. for Research & Technology
Vehicle Dynamics Division
AF Flight Dynamics Laboratory

ABSTRACT

A general methodology in Structural Dynamics based on the use of generalized coordinates is presented. These general methods are demonstrated by analysis of some of the problems of slender, conventional, launch vehicles. Applications of the general methodology are also given for complex configurations employing thin shell tanks in clustered arrangements. The methods of structural analysis and vibration analysis that are presented are not restricted to any particular geometry and apply to any complex redundantly coupled structure.

To further demonstrate the general methods, a vibration analysis of the clustered Saturn I launch vehicle is presented.

Contrails

Contrails

	<u>Page</u>
1.0 INTRODUCTION.	1
2.0 INTRODUCTION TO METHODS IN DYNAMICS FOR FINITE DEGREE-OF-FREEDOM MECHANICAL SYSTEMS.	7
2.1 Principles of Analytical Mechanics for Continuous Finite Degree-of-Freedom Systems.	9
2.1.1 An Introduction to Continuum Mechanics.	9
2.1.1.1 The Eulerian and Lagrangian Coordinate Descriptions.	9
2.1.1.2 The Equations of Continuity and Momentum.	11
2.1.1.3 A Formulation of the Principle of Virtual Work for a Continuous System.	16
2.1.2 Lagrange's Equations for Continuous Elastic Systems.	19
2.1.2.1 Lagrange's Equations for an Independent Set of Generalized Coordinates.	19
2.1.2.2 Lagrange's Equations for a Redundant Set of Generalized Coordinates.	25
2.1.2.3 Lagrange's Equations for Quasi-Coordinates.	27
2.2 The General Theory of Small Motions about a Point of Minimum Potential.	33
2.2.1 The Kinetic and Potential Energies.	33
2.2.2 The Equations of Motion.	37
2.2.3 General Solutions to the Vibration Equations.	38
2.2.3.1 The Homogeneous Equations of Free Vibration.	38
2.2.3.2 Orthogonality Relations for the Modal Columns.	40
2.2.3.3 Response of the Undamped System to External Forces Which Are a Function of Time Only.	43
2.2.3.4 The Zero-Frequency Modes of an Unrestrained System.	46
2.2.3.5 Solutions to the Linearly Damped Vibration Equations.	59
2.3 The Applications of an Interpolation Procedure for Obtaining a Finite Degree-of-Freedom Approximation for Continuous Elastic Structures.	71

Contents

	<u>Page</u>
2.3.1 The Kinematics of Small Motions.	71
2.3.2 Interpolation in One-Dimension.	74
2.3.3 Application of the Interpolation Technique to Some Typical Structures Problems.	82
2.3.3.1 The Vibration of a Uniform Beam.	82
2.3.3.2 The Vibration of a Uniform Simply-Supported Plate.	95
2.3.3.3 The Vibration of a Uniform Thin Ring.	105
2.3.3.4 The Analysis of Structures with Nonuniform Properties.	117
3.0 METHODS IN DYNAMICS AND AEROELASTICITY FOR SLENDER LAUNCH VEHICLES IN PLANE MOTION.	121
3.1 The Linear Aeroelastic Equations Governing the Small Lateral Motions of a Slender Launch Vehicle.	123
3.1.1 The Kinetic and Potential Energy and the Virtual Work of Aerodynamic and Servo Forces.	123
3.1.1.1 The Calculation of Basic Data for a Slender Controlled Vehicle.	123
3.1.1.1.1 The Kinetic Energy.	123
3.1.1.1.2 The Strain Energy.	125
3.1.1.1.3 Aerodynamic Forces.	126
3.1.1.1.4 Control Forces.	130
3.1.1.2 Rigid Body Checks on the Basic Data.	131
3.1.2 The Equations for Determining "Loads" and Transient Motion.	136
3.1.2.1 The Equations for Calculating Transient Internal Loads.	136
3.1.2.2 The Modal Equations of Motion.	138
3.1.2.3 The "Quasi-Rigid" Approximation and Aeroelastic Corrections to the Rigid-Body Stability Derivatives.	143
3.1.2.4 "Unit" Internal Loads Based on the Quasi-Rigid Approximation.	150
3.1.2.5 The Aeroelastic Effects of Large Axial Loads on Lateral Motions.	152
3.1.2.6 Modification of the Loads Equations to Include Gravity, Thrust, Drag, and Air Loads Due to Asymmetries.	159
3.1.2.6.1 The Virtual Work of Distributed Lateral Forces.	160
3.1.2.6.2 The Loads Equations Including Axial and Lateral Forces.	164

Contents

	<u>Page</u>
3.1.3 Aeroelastic Stability.	166
3.1.3.1 "Static" Stability of a Free Missile with Locked Controls.	166
3.1.3.1.1 Divergence for the Vehicle in Rectilinear Flight.	169
3.1.3.1.1.1 Collocation Method.	169
3.1.3.1.1.2 Modal Method.	173
3.1.3.1.2 Divergence for the Vehicle in Steady Flight in a Circular Path.	179
3.1.3.1.2.1 Collocation Method.	180
3.1.3.1.2.2 Modal Method.	184
3.1.3.2 Dynamic Stability with Locked Controls.	188
3.1.3.3 Solution of the Eigenvalue Problem for the Aeroelastic System.	195
3.1.3.4 General "Point" Stability with Closed Control Loop	206
3.1.3.5 Gimbaleed Engine Considerations in Closed Loop Stability.	214
3.1.3.6 Some General Considerations of the Influence of Fuel Slosh on the Lateral Motions of a Slender Launch Vehicle.	225
3.1.3.6.1 Dynamics of the Motion of the Fuel.	227
3.1.3.6.2 Solution of the Integral Equation.	233
3.1.3.6.3 Coupling of Sloshing Fuel with Launch Vehicle Motion.	238
3.1.3.7 Flutter and Divergence of Launch Vehicle Lifting Surfaces.	240
3.1.3.7.1 A General Method of Flutter and Divergence Analysis.	240
3.1.3.7.2 A Root-Plane Method of Flutter Analysis for Quasi-Steady Aerodynamic Forces.	248
3.1.4 Response of the Missile to Continuous Random Turbulence.	250
3.1.5 Dynamic Loads during Ground Transportation.	258

Contents

	<u>Page</u>
3.2 The Nonlinear Aeroelastic Equations Governing the Plane Motion of a Flexible Missile Executing Arbitrarily Large "Rigid-Body" Displacements.	263
3.2.1 The Kinematics of the Plane Motion of a Flexible Missile.	263
3.2.2 The Kinetic Energy.	265
3.2.3 The Approximation of a Finite Number of Degrees-of-Freedom.	268
3.2.4 The Strain Energy and the Virtual Work of External Forces.	272
3.2.5 The Equations for Transient Loads.	273
3.2.6 The Equations for the Trajectory.	275
3.2.7 The Relation between the Total Forces, F_x , F_y , and G_y and the Generalized Forces.	278
3.2.8 Detailed Description of External Forces.	282
3.2.8.1 Aerodynamic Forces.	282
3.2.8.2 Gravity Forces.	287
3.2.8.3 Thrust Forces.	289
3.2.8.4 Control System Forces.	291
3.2.9 Summary of Equations of Motion.	292
3.2.10 Control System Equations.	294
3.2.11 The Transformation to Modal Coordinates.	296
3.2.12 The Quasi-Rigid Approximation.	300
4.0 THE DYNAMICS OF AN UNRESTRAINED ELASTIC STRUCTURE IN GENERAL SIX-DEGREE-OF-FREEDOM MOTION.	305
4.1 The Equations of Motion of a Single Elastic Body Constituting a Fixed Set of Particles and Executing Large "Rigid-Body" Motions.	307
4.1.1 The Kinematics of an Elastic Body Executing Arbitrarily Large Displacements.	309
4.1.2 Derivation of the Equations of Motion from the Principle of Virtual Work.	315
4.1.3 The Kinetic Energy of the Body.	323
4.1.4 The Strain Energy of the Body.	336
4.1.5 The Dissipation Function for the Body.	338
4.1.6 The Complete Set of Differential Equations Governing the Motion of the Body.	343
4.2 The Complete Simulation of the Dynamics of a Flexible Boost Vehicle during the "In-Flight" Phase.	357
4.2.1 The Differential Equations Governing the Orientation of the Body and the Trajectory of the Center of Mass.	357
4.2.1.1 Euler Angles for the $(\hat{i}, \hat{j}, \hat{k})$ Frame of Reference.	357
4.2.1.2 Trajectory of the Center of Mass.	359

Contents

	<u>Page</u>
4.2.2 External Forces.	359
4.2.2.1 Gravity Forces.	360
4.2.2.2 Aerodynamic Forces.	362
4.2.2.3 Thrust Forces.	368
4.2.2.4 Control System Forces.	368
4.2.2.5 Summary of External Generalized Forces.	369
4.2.3 The Transformation to Modal Coordinates.	370
4.2.4 Transient Loads and Stresses	372
4.2.5 Final Equations of Motion	373
5.0 METHODS TO OBTAIN VIBRATION MODES FOR LARGE REDUNDANTLY COUPLED STRUCTURES.	375
5.1 The Problem of Vibration Analysis in Analytical Mechanics.	377
5.1.1 General Methods of Structural Analysis.	377
5.1.1.1 The Direct Stiffness Method.	380
5.1.1.2 The Complementary Energy Method.	384
5.1.1.3 Some General Considerations of Beam Theory.	391
5.1.1.3.1 The Computation of Beam Section Properties.	394
5.1.1.3.1.1 Bending Rigidity.	394
5.1.1.3.1.2 Torsion Rigidity for Thin Wall Sections.	395
5.1.1.3.1.3 Shear Rigidity for Thin Wall Cylinders.	401
5.1.1.3.2 Influence Coefficients for a Beam by the Complementary Energy Method.	404
5.1.2 Procedures for Calculating Inertia Matrices for Components of a Complex Structure.	410
5.1.2.1 Rigid Components.	410
5.1.2.2 One-Dimensional Flexible Components.	414
5.1.2.3 Two-Dimensional Flexible Components.	419
5.1.2.4 Inertia Matrices for Complex Structures.	423
5.1.3 The Methods of Modal Coupling.	423
5.1.3.1 Introduction - A Summary of the General Vibration Problem.	423
5.1.3.2 Modal Coupling of Elastically Uncoupled Components.	424
5.1.3.3 Modal Coupling of Elastically Coupled Systems.	431

Contents

	<u>Page</u>
5.2 Vibration Problems in Launch Vehicle Structures.	435
5.2.1 A Numerical Study and Comparison of Methods to Obtain Vibration Modes for Straight Beams.	435
5.2.1.1 The Exact Solution for the Continuous Beam.	437
5.2.1.2 Influence Coefficients by the Direct Stiffness Method.	439
5.2.1.3 Inertia Matrix Corresponding to the Direct Stiffness Approach.	447
5.2.1.4 Influence Coefficients by the Complementary Energy Method.	450
5.2.1.5 Inertia Matrix by Trapezoidal Interpolation.	451
5.2.1.6 Comparison and Conclusions.	
5.2.2 Vibration of Thin-Wall Cylinders.	452
5.2.2.1 A Study of Vibration Modes of Straight Beams with Thin-Wall Cylindrical Cross Sections.	454
5.2.2.1.1 Equations for a Beam Including Shear Energy and Rotary Inertia.	455
5.2.2.1.1.1 Timoshenko Beam.	457
5.2.2.1.1.2 Shear Energy Uncoupled from Rotary Inertia.	459
5.2.2.1.1.3 Shear Energy with no Rotary Inertia.	461
5.2.2.1.1.4 Euler-Bernoulli Beam.	461
5.2.2.1.2 Comparison and Conclusions.	461
5.2.2.2 Some Considerations of the Vibrations of Axially and Circumferentially Loaded Thin Cylindrical Shells.	465
5.2.2.2.1 Strain Energy for a Cylindrical Shell.	465
5.2.2.2.1.1 Strain-Displacement Relations for a Cylindrical Shell.	466
5.2.2.2.1.2 The Total Strain Energy Including Nonlinear Terms in the Strain- Displacement Relations.	469

Contents

	<u>Page</u>
5.2.2.2.2 The Kinetic Energy.	474
5.2.2.2.3 A Finite Degree-of-Freedom Representation of a Cylindrical Shell using Diparabolic Interpolation.	474
5.2.2.2.3.1 Description of the Method.	474
5.2.2.2.3.2 Analysis of a Copper Shell.	482
5.2.2.3 The Effects of Axial Load and Internal Pressure on the Vibration of Beams as Derived from Thin Shell Theory.	483
6.0 CONCLUSIONS AND RECOMMENDATIONS	489
7.0 LIST OF REFERENCES	490
APPENDIX I A DIGITAL ROUTINE FOR SOLVING THE EQUATIONS OF MOTION OF A SINGLE ELASTIC BODY EXECUTING LARGE "RIGID-BODY" MOTIONS AND ACTED UPON BY FORCES WHICH ARE A FUNCTION OF TIME ALONE.	493
APPENDIX II A VIBRATION ANALYSIS OF A ONE-FIFTH SCALE MODEL OF THE SATURN VEHICLE.	593
APPENDIX III COMPUTATIONAL PROCEDURES FOR FINITE DEGREE-OF-FREEDOM EIGENVALUE PROBLEMS.	655
APPENDIX IV INTERPOLATION AND INTEGRATION COEFFICIENTS FOR DIPARABOLIC INTERPOLATION.	663
APPENDIX V GLOSSARY OF TERMS USED IN THE TEXT.	723
APPENDIX VI THE GILL-RUNGE-KUTTA SCHEME OF NUMERICAL INTEGRATION.	729

Contrails

Contrails

LIST OF ILLUSTRATIONS

<u>Figure No.</u>	<u>Title</u>	<u>Page</u>
1	A Portion of the Continuum	9
2	Eulerian and Lagrangian Coordinates	11
3	Surface and Body Forces	13
4	A Virtual Displacement of the System	17
5	Illustrating the Region of Integration	18
6	Rigid Body in Plane Motion	27
7	Damping Characteristics from Measurements of $\zeta_1 \omega_1$ and $\sqrt{1-\zeta_1^2} \omega_1$	62
8	A Portion of the System Displaced from Its Equilibrium Position	72
9	Trapezoidal Interpolation	75
10	Diparabolic Interpolation	78
11	Uniform Beam	82
12	The "Assumed Modes" Corresponding to the Diparabolic Interpolation Method	94
13	The "Assumed Modes" Corresponding to the Trapezoidal Interpolation Method	95
14	Uniform Plate	96
15	Collocation Points on the Plate	97
16	Numbering of Points in the i^{th} Region	
17	Collocation Points for Simply-Supported Plate	103
18	Uniform Thin Ring	106
19	Collocation Points	108
20	Relation between the First and Last Interval	114
21	Approximation of Distribution of Structural Properties	119
22	Slender Controlled Vehicle	124

Contrails

LIST OF ILLUSTRATIONS (Continued)

<u>Figure No.</u>	<u>Title</u>	<u>Page</u>
23	Mass Distribution for a Slender Launch Vehicle	125
24	Bending Rigidity Distribution for a Slender Launch Vehicle	126
25	Local Angle-of-Attack	127
26	Running Air Load Distribution for a Slender Launch Vehicle	129
27	Generalized Coordinates for Rigid Missile	132
28	Collocation Point Displacements for the Rigid Missile	132
29	Internal Loads at the Collocation Points	137
30	Sign Convention for Control "Hinge" Moments	146
31	Axially Loaded Launch Vehicle	154
32	Distribution of Axial Component of Thrust	156
33	Distribution of Lateral Component of Thrust	156
34	Moment of the Thrust for a Rigid Missile	159
35	Distributed Lateral Forces	160
36	Distributed Thrust Force on the Flexible Missile	161
37	Concentrated Thrust Force Misaligned at an Angle, ϵ	161
38	The Uncontrolled Missile	166
39	Distribution of Loads in the Divergence Mode-Case of Rectilinear Flight	173
40	Dynamic Pressure of Divergence as a Function of the Number of Modes Considered-Case of Rectilinear Flight	176
41	Shape of the Missile in the Divergence Mode-Rectilinear Flight	179

Contrails

LIST OF ILLUSTRATIONS (Continued)

<u>Figure No.</u>	<u>Title</u>	<u>Page</u>
42	The Missile in Steady Circular Flight	181
43	Dynamic Pressure of Divergence as a Function of the Number of Modes Considered - Circular Flight Case	187
44	Locus of Missile Stability Roots for Varying Dynamic Pressure	193
45	Damping and Frequency of the Short Period Mode	194
46	Slender Launch Vehicle with Gimballed Engine	215
47	Time History of Signal to Servo	224
48	Liquid Fuel Tank and Launch Vehicle	225
49	Displacements of Sloshing Fuel	228
50	Estimation of β from Ground Vibration Test Data	247
51	Graphical Representation of Solution of Flutter Determinant	247
52	Locus of the Flutter Roots for a Parametric Variation of Flight Time	249
53	Damping versus Flight Time	250
54	Missile Encountering a Turbulent Atmosphere	251
55	Transfer Functions for Atmospheric Turbulence	257
56	Missile Transporter System	258
57	Idealization of Shock Mount	259
58	Inertial and Body Reference Systems	263
59	Aerodynamic Assumptions	283
60	Local Angle-of-Attack	283
61	Winds Resolved in the Inertial Reference System	286
62	Approximations to Inverse Square Gravity Field	287

Contrails

LIST OF ILLUSTRATIONS (Continued)

<u>Figure No.</u>	<u>Title</u>	<u>Page</u>
63	Equations for Plane Motion of a Flexible Launch Vehicle	301
64	Motion of an Elastic Body	308
65	Center-of-Mass for an Elastic Body	309
66	A Point Fixed in "Body" Axis Frame of Reference	310
67	Euler Angles	358
68	Gravity Forces	360
69	Idealized Distribution of Aerodynamic Forces	363
70	The Local Angle-of-Attack	364
71	The Local Angle-of-Sideslip	365
72	Equations for the General Motion of a Flexible Launch Vehicle	374
73	Subdivisions of Structure into "Members" and "Elements"	378
74	Displacement Continuity at a Joint between Elements of a Member	380
75	Free Body of a Portion of the Member Acted upon by the Reactions in an Element	385
76	Summary Comparison of the Direct Stiffness and the Complementary Energy Methods of Structural Analysis	390
77	Structure Idealized as a Beam	391
78	Geometry of a Beam	392
79	Stress Resultants on a Section	393
80	Multi-Cell Thin Wall Section	395
81	A Single Cell	396
82	Shearing Stresses	397

Contrails

LIST OF ILLUSTRATIONS (Continued)

<u>Figure No.</u>	<u>Title</u>	<u>Page</u>
83	Shear Stress on a Thin-Wall Cylinder	402
84	Loaded Beam	404
85	Geometry of the Beam and Subdivision into Elements	404
86	Loads at the End of an Element	405
87	Free Body of an Element	406
88	Free Body of Structure Adjacent to Element	408
89	Generalized Coordinates for a Rigid Body	411
90	Generalized Coordinates for a One-Dimensional Component	415
91	Generalized Coordinates for a Two-Dimensional Component	419
92	Two Elastically Uncoupled Components	425
93	Displacements of (B) with (A) Motionless	426
94	Two Elastically Coupled Components	432
95	Uniform Straight Beam	436
96	Collocation Points	436
97	Typical Element	440
98	Loads on an Element	441
99	Loads on the Portion of the Beam to the Left of $x = x_i$	450
100	Geometry of the Structure	454
101	Modes of a Beam with a Thin-Wall Cylindrical Cross Section	464
102	Thin Cylindrical Shell	465
103	Shell Displacements	467
104	Collocation Points for a Cylindrical Shell	474

Contracts

LIST OF ILLUSTRATIONS (Continued)

<u>Figure No.</u>	<u>Title</u>	<u>Page</u>
105	Inside of Developed Shell Showing Typical Region	475
106	Influence Coefficients for Simply-Supported Shell	
107	Slender Cylindrical Shell	485
108	Beam Displacements for a Cylindrical Shell	486
109	Form for Presenting Data to Routine	511
110	Example Vehicle	537
111	Model Dimensions	537
112	Generalized Coordinates	538
113	Deflections in the Symmetric Plane	539
114	Deflections in the Anti-Symmetric Plane	539
115	Saturn SA-1 Launch Vehicle	597
116	Components of Saturn Model	598
117	Collocation Point Geometry	599
118	Equivalent Beam	600
119	Collocation Point Geometry for Middle Stage	602
120	Equivalent Beam	603
121	Degrees-of-Freedom for Adapter	604
122	Generalized Adapter Loads	605
123	Collocation Point Geometry for Spider Beam	606
124	Generalized Coordinates for Spider Beam	606
125	Collocation Point Geometry for Center Lox Tank	608
126	Equivalent Beam	609
127	Collocation Point Geometry for Fuel Tank	610

Contracts

LIST OF ILLUSTRATIONS (Continued)

<u>Figure No.</u>	<u>Title</u>	<u>Page</u>
128	Equivalent Beam for Fuel Tank	611
129	Outrigger Degrees-of-Freedom	613
130	Vehicle Without Outer Lox Tanks	624
131	Second Component of Vehicle Without Outer Lox Tanks	625
132	Third Component of Vehicle Without Outer Lox Tanks	626
133	Fourth Component of Vehicle Without Outer Lox Tanks	627
134	Modal Coordinates of Fuel Tanks	631
135	Geometry of Outer Lox Tank	639
136	Collocation Points	640
137	Generalized Coordinates for the Ends	640
138	Cantilevered Outer Lox Tank	641
139	Outer Lox Tank on Simple Supports	641
140	Arrangement of Four Outer Lox Tanks	643
141	Geometry of Outer Lox Tank-Outrigger	644
142	Spider Beam-Outer Lox Tank Compatibility	646

Contrails

Contrails

LIST OF TABLES

<u>Table No.</u>	<u>Title</u>	<u>Page</u>
1	Frequencies of Uniform Beam, Collocation Method	93
2	Frequencies of Uniform Beam, Exact Solution	93
3	Modes of Uniform Beam	93
4	Frequencies of Simply-Supported Plate, $L/b = 3$, $\nu = 0.3$, Diparabolic Collocation	104
5	Frequencies of Simply-Supported Plate, $L/b = 3$, Exact Solution	104
6	Influence Matrix for a Simply-Supported Plate	105
7	Inertia Matrix for a Simply-Supported Plate	105
8	Dynamic Pressure of Divergence	187
9	Tabulation of Experimental Data from Ground Vibration Test	247
10	A Comparison of Several Methods to Obtain the Frequencies of a Straight Beam	453
11	Frequencies for a Cylindrical, Thin-Wall, Straight Beam Showing the Effects of Shear Energy and Rotary Inertia	463
12	Comparison of Frequencies for a Thin Copper Shell	484
13	Fortran Source Program Listings of Routine "Pandora"	519
14	Inertia Matrices of Multi-Cylinder Model	544
15	Stiffness Matrix of Multi-Cylinder Model	550
16	Damping Matrix of Multi-Cylinder Model	551
17	Vibration Modes and Frequencies of Multi- Cylinder Model	552
18	Data Read Into the Computer for Sample Runs	556
19	Listings of Computer Runs for Transient Gust Response	557

Contracts

LIST OF TABLES (Continued)

<u>Table No.</u>	<u>Title</u>	<u>Page</u>
20	Listings of Computer Runs for Impulsive Spin-Up Response	573
21	Listings of Computer Runs for Response to Initial Deformation	589
22	Upper Stage (U) Mass, Stiffness, and Cantilevered Modes	615
23	Middle Stage (M) Mass Matrix	616
24	Middle Stage (M) Influence Coefficients and Modes Cantilevered with Rigid Adapter	617
25	Spider Beam (S) Collocation Point Structural Influence Coefficients Matrix	618
26	Center Lox Tank (L) Mass Matrix	619
27	Center Lox Tank (L) Cantilevered Influence Coefficients and Modes	620
28	Fuel Tanks (F) Mass Matrix	621
29	Fuel Tanks (F) Simply-Supported Influence Coefficients and Modes	622
30	Bending and Shear Rigidity of Beam-Like Components	623
31	Geometric Transformation Matrices for the Elastically Uncoupled Components	635
32	Component Modes of Vehicle Without Outer Lox Tanks	636
33	Frequencies of the Vehicle Without Outer Lox Tanks	637
34	Two-Dimensional Diparabolic Interpolation Coefficients	665
35	Two-Dimensional Diparabolic Integration Matrices	668
36	Fortran Source Program Listing of Runge-Kutta Subroutine	736

Contrails

1.0 INTRODUCTION

Contrails

1.1 THE NATURE AND PURPOSE OF THIS REPORT

The purpose of this report is to provide a consistent methodology for solving structural dynamics problems associated with the design and operation of large, clustered, launch vehicles. The methods are motivated by the need to obtain:

- o Structural load design criteria
- o Control system design criteria
- o Operational capability and performance boundaries for boosted flight through the atmosphere.

The emphasis has been more on the methodology than on the selection of detailed design criteria. The attempt to establish rational design criteria, however, has been the guiding motivation for the methods that are documented herein.

This report was written with the intention of fully documenting a specific methodology which is in common use in the aerospace industry, but which has received limited treatment in the published literature. To be specific, the methodology referred to could be called "a finite degree-of-freedom approach to structural dynamics." The major part of this report is devoted to the detailed development of this general methodology. In subsequent sections of the report this methodology is demonstrated to be applicable to the launch vehicle dynamics problems associated with complex clustered configurations. Sufficient information is given in these latter sections to show that the methods of this report are general enough to cover the structural dynamics problems associated with non-beam-like launch vehicles (such as Titan III C and Saturn I B).

An attempt has been made in writing this report to show the extensive generality of the methods. This motive influenced the arrangement of the subject material. The following steps were taken to achieve this:

- (1) Section 2.0 provides a complete development of the methods from basic principles of mechanics for a continuum.
- (2) Section 3.0 demonstrates the applications of these methods to conventional, slender, launch vehicles.
- (3) Section 4.1 demonstrates the applications of the methods of Section 2.0 to an arbitrary deformable body.
- (4) Section 4.2 specializes the development in Section 4.1 to an "arbitrary" launch vehicle in boosted flight through the atmosphere.

- (5) Section 5.0 considers in detail some aspects of structural dynamics concerned with thin-wall tanks and clustered arrangements.
- (6) Finally, Appendix II provides an example numerical analysis of a specific clustered configuration to further demonstrate the general application of the methods, and to clarify the discussion in Section 5.0.

The example analysis in Appendix II is a detailed documentation of a vibration analysis. The configuration chosen is that of the Saturn I launch vehicle. The vibration modes and frequencies are calculated for data corresponding to the NASA Langley one-fifth scale structural model of the first Saturn vehicle (serial designation SA-1) that was launched in October, 1961.

In addition to the Saturn analysis, several numerical examples are given where data have been conveniently available. The examples in Section 3.0 are primarily based on data for the NASA Scout solid-propellant launch vehicle. Practical limitations have made it necessary to omit additional numerical examples.

1.2 HISTORICAL INTRODUCTION TO THE METHODS OF THIS REPORT

The methods of this report are not novel, nor are they revolutionary or new to the aerospace industry. They have been used under many different names. Some typical examples are:

- o matrix method
- o generalized coordinate approach
- o collocation method
- o energy method
- o Lagrangian approach
- o Rayleigh-Ritz method
- o modal method

This report attempts to put these methods in order and show how they are all generated from the same basic notions. Since the scope of this report is necessarily restricted to launch vehicle dynamics this purpose is limited and the need still exists for a broader synthesis of these basic methods in structural dynamics.

It has been suggested in Paragraph 1.1 that we call this general method a "finite degree-of-freedom approach to structural dynamics," a name which must suffice until we can indicate more specifically what is involved.

Contrails

The methods of this report rely completely on the principles of Analytical Mechanics; namely, the Principle of Virtual Work and its extension to dynamics by D'Alembert's Principle. These principles were used by Lagrange to develop Analytical Mechanics by use of his method of generalized coordinates. Lagrange's boast was that his methods were independent of geometry and he took pride in noting that his treatise, Mécanique Analytique, did not contain a single figure. It seems remote, but it is this characteristic of Lagrange's method which makes it useful in structural dynamics. The usefulness stems from the fact that equations of motion are developed which apply to any configuration because they are essentially independent of the geometry of any particular configuration.

The engineering discipline which is currently called structural dynamics and aeroelasticity dates back to the beginning of powered flight and received impetus with the first mathematical analysis of the flutter mechanism by Theodorsen and Garrick in 1934. During this period of development, Lagrange's approach has been used repeatedly with success in vibration and aeroelastic problems. The British, however, have tended to use the method more faithfully than it has been used in this country.

The extensive use of the Lagrangian method at LTV Astronautics is principally due to S. J. Loring. As early as 1936, Loring had developed the use of the method in a general finite degree-of-freedom approach utilizing matrices. Loring came to Chance Vought Aircraft¹ in 1936 and exerted a significant influence on the structures capability of that company in the period from 1936 to 1948. Due to the obscurity of his publications², Loring's work did not influence the general trends in aeroelasticity during that period. Outside of Chance Vought, the subject evolved independently from the following sources:

- o NASA, Langley Field, Virginia, due to the contributions of T. Theodorsen and I. E. Garrick: NACA TR No. 496, General Theory of Aerodynamic Instability and the Mechanism of Flutter, 1934.
- o Wright Field, Dayton, Ohio, due to the basic approach documented by Smilg and Wasserman: Air Force Technical Report 4798, Application of Three-Dimensional Flutter Theory to Aircraft Structures, 1942. (The existing military specifications on aeroelastic problems have been largely influenced by this document.)
- o Massachusetts Institute of Technology, due to the contributions of R. L. Bisplinghoff, H. Ashley, G. Zartarian, R. L. Halfman and others in the Aeronautical Department and in the Aeroelastic and Structures Research Laboratory.

¹ Chance Vought is a parent organization of LTV Astronautics, a division of Ling-Temco-Vought, Inc.

² For example, Loring's publications in the SAE Journal are not included in the extensive bibliography of the book Aeroelasticity (Addison-Wesley, 1955) by Bisplinghoff, Ashley and Halfman.

Contrails

- o California Institute of Technology, due to the contributions of Y. C. Fung: Elastostatic and Aeroelastic Problems Relating to Thin Wings of High-Speed Airplanes, (Ph.D. Thesis, 1948) and Theory of Aeroelasticity (Wiley, 1955).

The methods of this report do not reflect directly the extensive and significant contributions of the above sources, but are almost entirely devoted to the independent contributions of Loring and the subsequent development of his ideas by M. J. Turner, Dr. W. W. Soroka, S. Rabinowitz, Dr. Conrad C. Wan, J. E. Stevens, R. Simon, Dr. H. A. Wood, Dr. Ta C. H. Li, Dr. J. K. Haviland, A. L. Head, Jr., and others who have been connected with Chance Vought over the past twenty years. In spite of the obscurity of his publications¹, Loring's work has, nevertheless, influenced the industry through the engineers which have left Chance Vought and gone to other companies.

¹ S. J. Loring, General Approach to the Flutter Problem, SAE Journal (Transactions) volume 49, No. 2, January 6, 1940 and Use of Generalized Coordinates in Flutter Analysis, SAE Journal, volume 52, No. 4, April 1944.

2.0 INTRODUCTION TO METHODS IN DYNAMICS
FOR
FINITE DEGREE-OF-FREEDOM MECHANICAL SYSTEMS

Contrails

2.1 PRINCIPLES OF ANALYTICAL MECHANICS FOR CONTINUOUS FINITE DEGREE-OF-FREEDOM SYSTEMS

2.1.1 An Introduction to Continuum Mechanics

In dealing with the motion of a flexible launch vehicle interacting with its fuel and the surrounding atmosphere there are numerous opportunities to call upon fundamental principles related to the dynamics of a continuum of mass particles. For this reason we want to review these principles, in this section, in a form and notation which will clarify discussions in subsequent sections.¹ Most of the conceptual difficulties with the dynamics of "open" systems (such as a vehicle losing mass) arise because care is not exercised in analyzing the detailed motions of the particles of the system. It is felt that these difficulties and others may be avoided by a preliminary consideration of the equations of continuum mechanics.

2.1.1.1 The Eulerian and Lagrangian Coordinate Descriptions

Consider an arbitrary, finite portion of a continuum of particles at a time, say, $t = 0$.

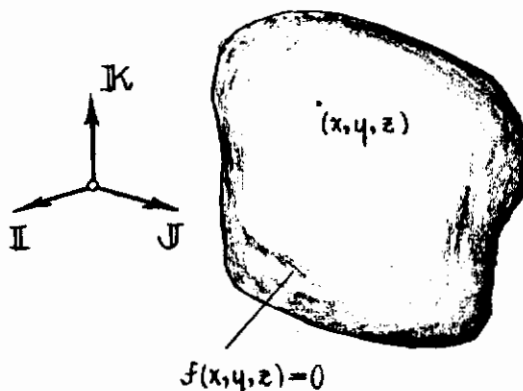

FIGURE 1 A PORTION OF THE CONTINUUM

Let \mathbf{I} , \mathbf{J} , and \mathbf{K} be a set of inertial unit base vectors directed along the axes of a rectangular coordinate system, (x, y, z) whose origin is fixed. At $t = 0$ let the arbitrary surface bounding this set of particles be given in

¹For a more complete discussion, reference should be made to Green and Zerna, Theoretical Elasticity, Oxford, 1954, or Truesdell, Principles of Continuum Mechanics, Colloquium Lectures in Pure and Applied Science No. 5 Socony Mobil Oil Co. Field Research Laboratory, Dallas, Texas, February 1960.

Contrails

the implicit form

$$f(x, y, z) = 0 \quad (2-1)$$

We may "tag" or give an identity to each of the continuum of particles by associating that particle with the coordinates, (x, y, z) , of the point occupied by the particle at $t = 0$. Even though the particle is displaced from this point in subsequent times, we continue to call it the "x-y-z particle." A set of coordinates, such as these, which label particles are termed "Lagrangian coordinates."

The particles which, at time $t = 0$, have coordinates, (x, y, z) , are continuously displaced to new positions which have coordinates, say, (ξ, η, ζ) referred to the original inertial reference frame. The kinematics of the motion is completely described by the set of functions

$$\begin{aligned} \xi &= \xi(x, y, z, t) \\ \eta &= \eta(x, y, z, t) \\ \zeta &= \zeta(x, y, z, t) \end{aligned} \quad (2-2)$$

These equations give the coordinates of a point which, at time t , is occupied by the x-y-z particle. Because of our definitions of x , y , and z , these equations satisfy the peculiar relations,

$$\begin{aligned} x &= \xi(x, y, z, 0) \\ y &= \eta(x, y, z, 0) \\ z &= \zeta(x, y, z, 0) \end{aligned} \quad (2-3)$$

In a concise manner we have the position vector, $\mathbb{M}(x, y, z, t)$, of the x-y-z particle at time, t , given by

$$\mathbb{M}(x, y, z, t) = \xi(x, y, z, t) \mathbb{I} + \eta(x, y, z, t) \mathbb{J} + \zeta(x, y, z, t) \mathbb{K} \quad (2-4)$$

The coordinates, (ξ, η, ζ) , are termed "Eulerian coordinates" for the particles.

The velocity of the x-y-z particle is defined by

$$\mathbb{V}(x, y, z, t) = \frac{\partial \mathbb{M}}{\partial t}(x, y, z, t) \quad (2-5)$$

and likewise the acceleration of the x-y-z particle is defined by

$$a(x, y, z, t) = \frac{\partial^2 \eta}{\partial t^2}(x, y, z, t) \quad (2-6)$$

The Eulerian and Lagrangian coordinate descriptions are summarized in Figure 2.

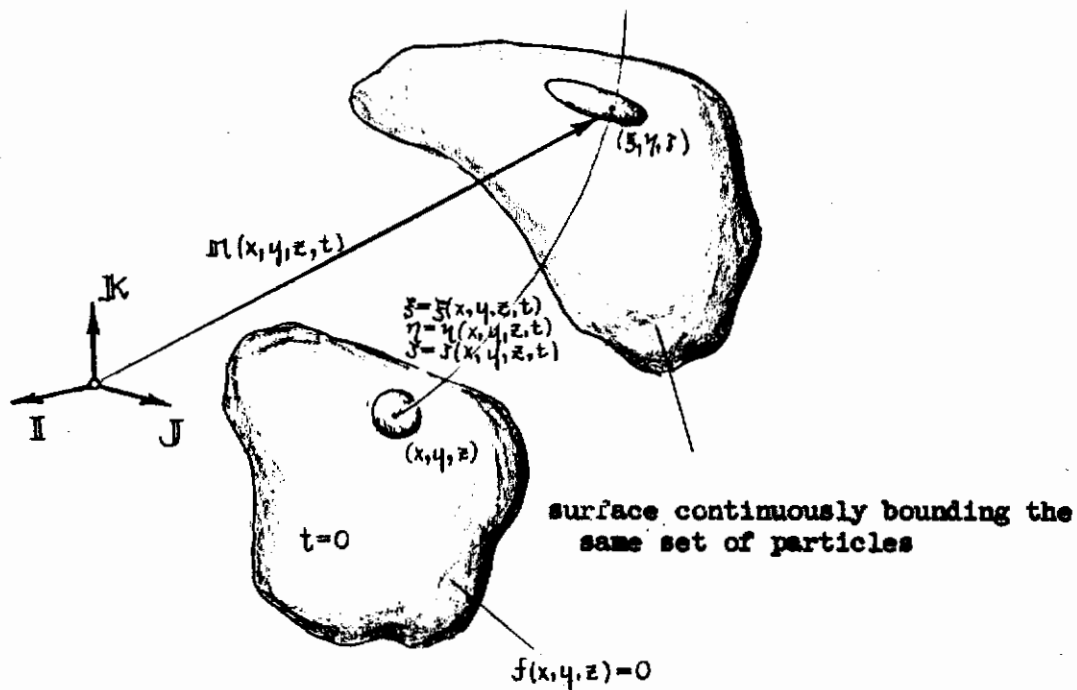

FIGURE 2 EULERIAN AND LAGRANGIAN COORDINATES

2.1.1.2 The Equations of Continuity and Momentum

Let the mass per unit of volume in the neighborhood of the point (x,y,z) at time, t = 0, be denoted by

$$\rho = \rho(x, y, z) \quad (2-7)$$

Contrails

The total mass of the arbitrary portion inside the surface, $f(x,y,z) = 0$, which bounds this fixed set of particles is given by¹

$$\int_{f(x,y,z)=0} \rho(x,y,z) dV \quad (2-8)$$

The conservation of mass in nonrelativistic continuum mechanics is expressed by the trivial relation

$$\frac{d}{dt} \int_{f(x,y,z)=0} \rho dV = 0 \quad (2-9)$$

The conservation of momentum is similar and is derived from a form of Newton's second law in classical mechanics. The problem, however, is not conceptually straightforward because of the nondifferentiable nature of the forces on a mass-point in a continuum. Invoking Newton's second law, we have

$$\int \frac{\partial^2 m}{\partial t^2}(x,y,z,t) \rho(x,y,z) dV = \int dF(x,y,z,t) \quad (2-10)$$

where the integral on the right should be interpreted as a generalization of the Stieltjes definition of an integral. Upon integrating over the fixed set of particles inside $f(x,y,z) = 0$ at $t = 0$, we have

$$\int_{f(x,y,z)=0} \frac{\partial^2 m}{\partial t^2} \rho dV = F \quad (2-11)$$

The total force, F , on this finite set of particles is given by contributions from a surface and a volume integral

$$F = \oint \Sigma \cdot dS + \int P dV \quad (2-12)$$

¹ $\int(\)dV$ is used to denote the volume integral $\iiint(\)dx dy dz$

Contrails

where Σ is the stress dyadic¹ and \mathbb{P} is the so-called body-force per unit of volume.

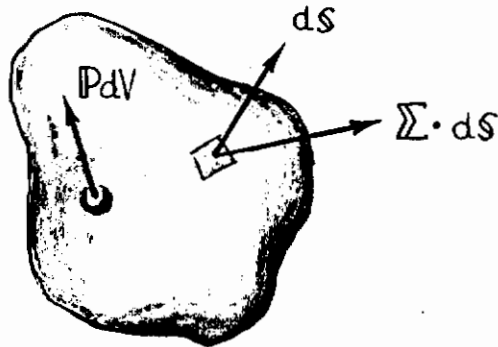

FIGURE 3 SURFACE AND BODY FORCES

The identity,

$$\frac{d}{dt} \int_{f(x,y,z)=0} \rho \frac{\partial \pi}{\partial t} dV = \int_{f(x,y,z)=0} \frac{\partial^2 \pi}{\partial t^2} \rho dV \quad (2-13)$$

is true because our consideration of a fixed set of particles makes the limits of integration independent of time. Using this, along with the definition of velocity (Equation 2-5), in Equation 2-11 yields

$$\frac{d}{dt} \int_{f(x,y,z)=0} \rho v dV = \oint \Sigma \cdot dS + \int_{f(x,y,z)=0} \mathbb{P} dV \quad (2-14)$$

Equations 2-9 and 2-14 express the principles of the conservation of mass and momentum in terms of Lagrangian coordinates. Our aim will be to transform these to expressions in Eulerian coordinates; but, before this, we want to introduce the Eulerian notion of mass density. The relations which give the "label," (x,y,z) , of a particle which at time, t , is at the point (ξ, η, ζ) are given by the inverse of Equations 2-2

$$\begin{aligned} x &= x(\xi, \eta, \zeta, t) \\ y &= y(\xi, \eta, \zeta, t) \\ z &= z(\xi, \eta, \zeta, t) \end{aligned} \quad (2-15)$$

¹See Constant, Theoretical Physics, Addison-Wesley, 1954 p. 40 and p. 201.

Contrails

If we use these equations to make a change of variable in Equation 2-9, we have

$$\int_{f(x,y,z)=0} \rho dV = \iiint_{f(x(\xi,\eta,\zeta,t), y(\xi,\eta,\zeta,t), z(\xi,\eta,\zeta,t))=0} \rho(x(\xi,\eta,\zeta,t), y(\xi,\eta,\zeta,t), z(\xi,\eta,\zeta,t)) \frac{\partial(x,y,z)}{\partial(\xi,\eta,\zeta)} d\xi d\eta d\zeta \quad (2-16)$$

where $\frac{\partial(x,y,z)}{\partial(\xi,\eta,\zeta)}$ is the Jacobian associated with the transformation expressed by Equations 2-15. The nature of the Jacobian plays an important part in the Eulerian notion of density. The Jacobian is the ratio of the volume element, $dx dy dz$, to the "deformed" volume element, $d\xi d\eta d\zeta$. From this it follows that

$$\rho(x,y,z) \frac{\partial(x,y,z)}{\partial(\xi,\eta,\zeta)}$$

has the physical interpretation of the mass per unit of deformed volume. We then define a density function for Eulerian variables by

$$\rho(\xi,\eta,\zeta,t) = \rho(x,y,z) \frac{\partial(x,y,z)}{\partial(\xi,\eta,\zeta)} \quad (2-17)$$

In like manner, we define a body force per unit mass for Eulerian variables by

$$P(\xi,\eta,\zeta,t) = \frac{P(x,y,z,t)}{\rho(x,y,z) \frac{\partial(x,y,z)}{\partial(\xi,\eta,\zeta)}} \quad (2-18)$$

For conciseness, we denote the instantaneous surface bounding the fixed set of particles by

$$F(\xi,\eta,\zeta,t) \equiv f(x(\xi,\eta,\zeta,t), y(\xi,\eta,\zeta,t), z(\xi,\eta,\zeta,t)) = 0 \quad (2-19)$$

If we use Equation 2-15 to transform Equations 2-9 and 2-14 to Eulerian variables, we obtain

$$\frac{d}{dt} \int_{F(\xi,\eta,\zeta,t)=0} \rho dV = 0 \quad (2-20)$$

$$\frac{d}{dt} \int_{F(\xi,\eta,\zeta,t)=0} \rho v dV = \iint \Sigma \cdot dS + \int_{F(\xi,\eta,\zeta,t)=0} P \rho dV \quad (2-21)$$

Contrails

The surface integral in Equation 2-21 is a vector invariant in form and hence unaltered by this consideration of a transformation to Eulerian coordinates. Also, it should be emphasized that the ρ , and \mathbb{P} , in Equations 2-20 and 2-21 are the Eulerian counterparts defined in Equations 2-17 and 2-18.

To derive the Eulerian differential equations of continuity and momentum, we must carry out the time differentiation indicated in Equations 2-20 and 2-21. It should be noted that this operation is not as trivial as for the case when the integral was expressed in Lagrangian coordinates. The integrals have time-dependent limits of integration when expressed in Eulerian coordinates. We must invoke a generalization of Leibnitz's rule for differentiating an integral. We state this theorem without proof¹.

$$\frac{d}{dt} \int () dV = \int \frac{\partial}{\partial t} () dV + \oint () \mathbf{v} \cdot d\mathbf{S} \quad (2-22)$$

In this expression, \mathbf{v} is the velocity of points on the surface that describe the limits of integration.

In our applications, the velocity of the surface coincides with the velocity of particles (since no mass crosses the bounding surface). Also, the last term in Equation 2-22 can be transformed into a volume integral by use of the divergence theorem.

$$\frac{d}{dt} \int () dV = \int \left(\frac{\partial}{\partial t} () + \nabla \cdot (\mathbf{v}) \right) dV \quad (2-23)$$

If we apply this to the left-hand side of Equations 2-20 and 2-21, we obtain

$$\frac{d}{dt} \int_{F(\xi, \eta, \zeta, t)=0} \rho \mathbf{v} dV = \int_{F(\xi, \eta, \zeta, t)=0} \left(\frac{\partial}{\partial t} (\rho \mathbf{v}) + \nabla \cdot (\rho \mathbf{v} \mathbf{v}) \right) dV \quad (2-24)$$

$$\frac{d}{dt} \int_{F(\xi, \eta, \zeta, t)=0} \rho dV = \int_{F(\xi, \eta, \zeta, t)=0} \left(\frac{\partial \rho}{\partial t} + \nabla \cdot (\rho \mathbf{v}) \right) dV \quad (2-25)$$

If we use the divergence theorem on the surface forces in Equation 2-21, we may write Equations 2-24 and 2-25 as

$$\int \left(\frac{\partial \rho}{\partial t} + \nabla \cdot (\rho \mathbf{v}) \right) dV = 0 \quad (2-26)$$

¹A heuristic proof for this theorem is given in several places. In particular it is discussed in Lectures in Fluid Mechanics by Sydney Goldstein, Interscience, 1960.

$$\int \left(\frac{\partial(\rho V)}{\partial t} + \nabla \cdot (\rho V V) - \nabla \cdot \Sigma - \rho P \right) dV = 0 \quad (2-27)$$

Since the portion of the continuum we considered was arbitrary, we must conclude that the integrands of the above expressions are zero at each point, (ξ, η, ζ) , of the continuum of mass particles. The Eulerian equations of continuity and momentum are then

$$\frac{\partial \rho}{\partial t} + \nabla \cdot (\rho V) = 0 \quad (2-28)$$

$$\frac{\partial(\rho V)}{\partial t} + \nabla \cdot (\rho V V) = \nabla \cdot \Sigma + \rho P \quad (2-29)$$

The Lagrangian counterpart of these equations is derived by applying the divergence theorem to the surface forces in Equation 2-12. The Lagrangian equations of continuity and momentum are then

$$\frac{\partial \rho}{\partial t} = 0 \quad (2-30)$$

$$\rho \frac{\partial^2 \pi}{\partial t^2} = \nabla \cdot \Sigma + P \quad (2-31)$$

The first equation just expresses the trivial fact that the Lagrangian density function is not dependent on time. It should be noted, again, that ρ , P , and Σ are defined differently in the above sets of equations, but there is rarely any occasion for using both the Eulerian and Lagrangian equations together so that no attempt will be made to give them different notations.

We will have numerous opportunities in this report to use Equations 2-28 and 2-29 or Equation 2-31. In particular, we want to use Equation 2-31 to derive a form of the Principle of Virtual Work which is useful for the derivation of the equations of motion of a flexible vehicle.

2.1.1.3 A Formulation of the Principle of Virtual Work for a Continuous System

In the conventional manner we define a virtual displacement as one which carries each particle of the system into an imagined configuration in the "neighborhood" of the true configuration of the system at time t .

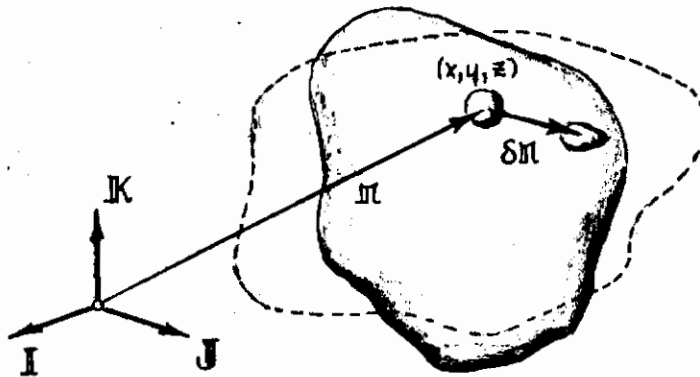

FIGURE 4 A VIRTUAL DISPLACEMENT OF THE SYSTEM

If we denote this virtual displacement by $\delta \mathbf{r}$, the position vector for the x-y-z particle in the neighboring configuration is $\mathbf{r} + \delta \mathbf{r}$. The virtual work of all the forces of the system (including the D'Alembert inertia forces) is

$$\delta W = \int_{f(x,y,z)=0} (\nabla \cdot \Sigma + \mathcal{P} - \rho \frac{\partial^2 \mathbf{r}}{\partial t^2}) \cdot \delta \mathbf{r} dV \quad (2-32)$$

which is zero because of Equation 2-31. We may elevate this statement to the level of a principle, or an axiom, by postulating that $\delta W = 0$ even when constraint forces are excluded from Σ and \mathcal{P} . With the understanding that constraint forces are not to be included in the definition of \mathcal{P} and Σ , we have

$$\delta W = \int_{f(x,y,z)=0} (\nabla \cdot \Sigma + \mathcal{P} - \rho \frac{\partial^2 \mathbf{r}}{\partial t^2}) \cdot \delta \mathbf{r} dV = 0 \quad (2-33)$$

which is the Principle of Virtual Work for a closed system (i.e., a fixed set of particles).

The Principle of Virtual Work can be extended to open systems (where mass crosses the boundary of the system) by considering the Eulerian equations of continuity and momentum (Equations 2-28 and 2-29). If we again exclude constraint forces from the body and surface forces and integrate over a fixed region in space, the total virtual work becomes

$$\delta W = \int_{F(\xi, \eta, \zeta) = 0} (\nabla \cdot \Sigma + \rho P - \frac{\partial}{\partial t}(\rho \mathbf{v}) - \nabla \cdot (\rho \mathbf{v} \mathbf{v})) \cdot \delta \mathbf{n} \, dV = 0 \quad (2-34)$$

If we now transform this back to Lagrangian coordinates, then

$$F(\xi(x, y, z, t), \eta(x, y, z, t), \zeta(x, y, z, t)) = f(x, y, z, t) = 0 \quad (2-35)$$

is the time varying surface bounding the particles which at time, t , are inside the fixed region in space described by $F(\xi, \eta, \zeta) = 0$.¹

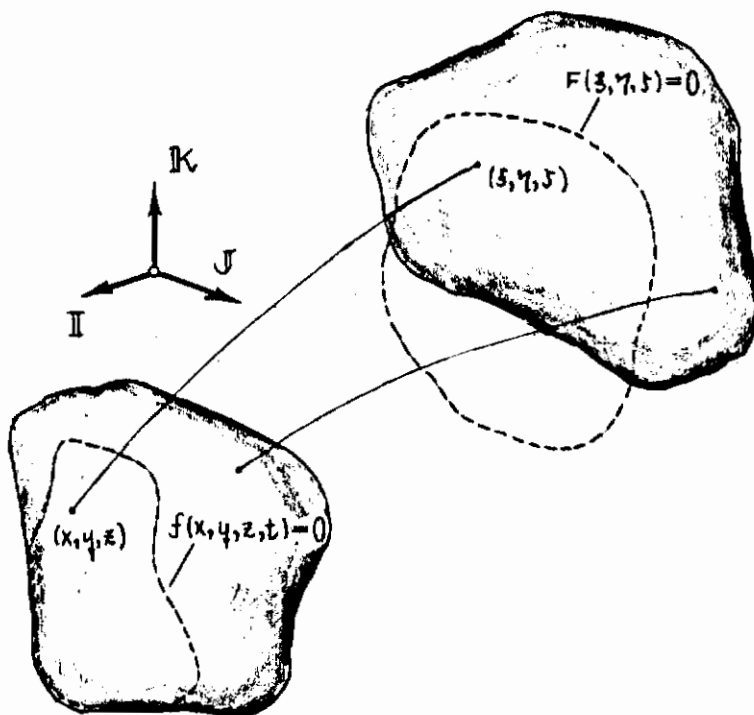

FIGURE 5 ILLUSTRATING THE REGION OF INTEGRATION

¹In the language of modern mathematical analysis, $f(x, y, z, t)$ is the "inverse image" of the region of the continuum inside $F(\xi, \eta, \zeta) = 0$ at time, t .

The integral (Equation 2-34) becomes (the derivation follows closely that given for the transformation leading to Equations 2-26 and 2-27)

$$\delta W = \int_{f(x,y,z,t)=0} (\nabla \cdot \Sigma + P - \rho \frac{\partial^2 \Pi}{\partial t^2}) \cdot \delta \Pi \, dV = 0 \quad (2-36)$$

From this we must conclude that the Principle of Virtual Work holds for open systems. This must be qualified by noting that forces acting at the boundary of the system that are constraint forces for the interaction of the system with its surroundings must, nevertheless, be included in the virtual work for the system alone.

Following the convention of Whittaker and Lanczos¹, we shall refer to the formulation of mechanics conceived by Lagrange and Hamilton as Analytical Mechanics in contrast to Newton's formulation which we shall call Vectorial Mechanics. The term "vectorial" refers to the fact that Newton's laws are relations between vectors. The governing equations in Analytical Mechanics, however, involve scalars such as kinetic energy and potential energy. In this report, the methods of Analytical Mechanics will be used exclusively. The fundamental principle of Analytical Mechanics is the Principle of Virtual Work.

2.1.2 Lagrange's Equations for Continuous Elastic Systems

A more practical formulation of the Principle of Virtual Work can be obtained for a system with a finite (or countably infinite) number of degrees-of-freedom. In those cases the configuration of the system can be prescribed by a finite number of functions of time. A set of such functions is called generalized coordinates. We shall call them independent generalized coordinates when they may be independently varied without violating the kinematical constraints of the system. In this case, the number of functions required is equal to the number of degrees-of-freedom. If the number of generalized coordinates is greater than the number of degrees-of-freedom, there must exist constraint relations between these coordinates which insure that the kinematical constraints of the system are not violated. We will call these "redundant generalized coordinates."

2.1.2.1 Lagrange's Equations for an Independent Set of Generalized Coordinates

If we denote the generalized coordinates by $p_j(t)$, $j = 1, 2, \dots, N$, the position vector of the x-y-z-particle can be written as a function of these N coordinates² (N is the number of degrees-of-freedom).

$$\Pi = \Pi(p_1, p_2, \dots, p_N; x, y, z, t) \quad (2-37)$$

¹See E. T. Whittaker, A Treatise on the Analytical Dynamics of Particles and Rigid Bodies, Cambridge, 1961, or Cornelius Lanczos, The Variational Principles of Mechanics, Toronto Press, 1949, p. 3.

²The assumption is tacitly made here that the constraints of the system are holonomic (see Lanczos, The Variational Principles of Mechanics, p. 24.).

Constraints

The explicit dependence on time is included to account for the case of time dependent constraints.

A completely general and arbitrary virtual displacement can be imagined by giving an arbitrary variation, δp_j , to each of the generalized coordinates. The position vector of each particle in this neighboring configuration is

$$\mathcal{M}(p_1 + \delta p_1, p_2 + \delta p_2, \dots, p_N + \delta p_N; x, y, z, t) \quad (2-38)$$

If we attribute a differential nature to the δp_j , the virtual displacement of each particle is

$$\delta \mathcal{M} = \sum_{j=1}^N \frac{\partial \mathcal{M}}{\partial p_j} \delta p_j \quad (2-39)$$

Substituting this into Equation 2-33 we obtain

$$\delta W = \sum_{j=1}^N \int (\nabla \cdot \Sigma + \mathcal{P} - e \frac{\partial^2 \mathcal{M}}{\partial t^2}) \cdot \frac{\partial \mathcal{M}}{\partial p_j} dV \delta p_j = 0 \quad (2-40)$$

Care must be exercised at this point because the partial derivatives of \mathcal{M} are defined differently in Equations 2-33 and 2-39. Difficulty may be avoided by regarding x , y , and z as only of parametric significance. By careful manipulation it can be shown that the following identity is true.

$$\int_{f(x,y,z)=0} e \frac{\partial^2 \mathcal{M}}{\partial t^2} \cdot \frac{\partial \mathcal{M}}{\partial p_j} dV = \frac{d}{dt} \left(\frac{\partial}{\partial p_j} \int_{f(x,y,z)=0} \frac{e}{2} \frac{\partial \mathcal{M}}{\partial t} \cdot \frac{\partial \mathcal{M}}{\partial t} dV \right) - \frac{\partial}{\partial p_j} \int_{f(x,y,z)=0} \frac{e}{2} \frac{\partial \mathcal{M}}{\partial t} \cdot \frac{\partial \mathcal{M}}{\partial t} dV \quad (2-41)$$

The derivation depends upon the limits of integration being independent of time so that our considerations here apply only to closed systems. Equation 2-41 can be written more concisely by introducing the definition of kinetic energy.

$$\tau = \frac{1}{2} \int_{f(x,y,z)=0} e \left(\frac{\partial \mathcal{M}}{\partial t} \right)^2 dV \quad (2-42)$$

We may then write

$$\int e \frac{\partial^2 \mathcal{M}}{\partial t^2} \cdot \frac{\partial \mathcal{M}}{\partial p_j} dV = \frac{d}{dt} \left(\frac{\partial \tau}{\partial p_j} \right) - \frac{\partial \tau}{\partial p_j} \quad (2-43)$$

Contrails

Let us now direct our attentions to the other terms in Equation 2-40. The expression

$$\int (\nabla \cdot \Sigma + P) \cdot \frac{\partial \pi}{\partial p_j} dV \quad (2-44)$$

is, by definition, the generalized force associated with the j^{th} generalized coordinate. We may separate this into internal and external forces by adding and subtracting the term

$$\int \nabla \cdot \left(\Sigma \cdot \frac{\partial \pi}{\partial p_j} \right) dV \quad (2-45)$$

We then have

$$\begin{aligned} \int (\nabla \cdot \Sigma + P) \cdot \frac{\partial \pi}{\partial p_j} dV &= \int \left(P \cdot \frac{\partial \pi}{\partial p_j} + \nabla \cdot \left(\Sigma \cdot \frac{\partial \pi}{\partial p_j} \right) \right) dV \\ &\quad + \int \left(\nabla \cdot \Sigma \cdot \frac{\partial \pi}{\partial p_j} - \nabla \cdot \left(\Sigma \cdot \frac{\partial \pi}{\partial p_j} \right) \right) dV \end{aligned} \quad (2-46)$$

The divergence theorem can be applied to the first term which we then recognize as the contribution from externally applied forces. Thus we define P_j to be the generalized forces other than internal forces.

$$P_j = \int P \cdot \frac{\partial \pi}{\partial p_j} dV + \oint \frac{\partial \pi}{\partial p_j} \cdot \Sigma \cdot dS \quad (2-47)$$

The external generalized forces can always be derived from the virtual work of the external forces in the form

$$\delta W = \int \delta \pi \cdot P dV + \oint \delta \pi \cdot \Sigma \cdot dS = \sum_{j=1}^N \delta p_j P_j \quad (2-48)$$

which is equivalent to Equation 2-47 because of Equation 2-39. Equation 2-46 then becomes

$$\int (\nabla \cdot \Sigma + P) \cdot \frac{\partial \pi}{\partial p_j} dV = P_j + \int \left(\nabla \cdot \Sigma \cdot \frac{\partial \pi}{\partial p_j} - \nabla \cdot \left(\Sigma \cdot \frac{\partial \pi}{\partial p_j} \right) \right) dV \quad (2-49)$$

Contrails

The second term is the contribution of internal forces to the j^{th} generalized force. The integrand of this term can be written slightly more concisely by using the notation of cartesian tensors¹.

$$\nabla \cdot \sum \frac{\partial \pi}{\partial p_j} - \nabla \cdot \left(\sum \frac{\partial \pi}{\partial p_j} \right) \rightarrow \frac{\partial \sigma_{ik}}{\partial x_i} \frac{\partial \xi_k}{\partial p_j} - \frac{\partial}{\partial x_i} \left(\sigma_{ik} \frac{\partial \xi_k}{\partial p_j} \right) = - \sigma_{ik} \frac{\partial}{\partial p_j} \left(\frac{\partial \xi_k}{\partial x_i} \right) \quad (2-50)$$

In the case of small motions and linear one-dimensional stress-strain relations, we can write

$$\sigma_{ik} \frac{\partial}{\partial p_j} \left(\frac{\partial \xi_k}{\partial x_i} \right) = \sigma \frac{\partial}{\partial p_j} \left(\frac{\sigma}{E} \right) = \frac{\partial}{\partial p_j} \left(\frac{\sigma^2}{2E} \right) = \frac{\partial}{\partial p_j} \left(\frac{1}{2} E \epsilon^2 \right) \quad (2-51)$$

which indicates the existence of a potential, $u = \frac{1}{2} E \epsilon^2$ (E is Young's modulus). In the general case we can do little more than postulate the existence of a potential for the internal forces. On the basis that the internal forces are conservative we assume that u exists such that²

$$\nabla \cdot \sum \frac{\partial \pi}{\partial p_j} - \nabla \cdot \left(\sum \frac{\partial \pi}{\partial p_j} \right) = - \frac{\partial u}{\partial p_j} \quad (2-52)$$

(u is called the specific internal energy for the x-y-z-particle at time, t.)

To account for non-conservative internal forces, we may achieve a little more generality by introducing a "dissipation function" r, such that

$$\nabla \cdot \sum \frac{\partial \pi}{\partial p_j} - \nabla \cdot \left(\sum \frac{\partial \pi}{\partial p_j} \right) = - \frac{\partial u}{\partial p_j} - \frac{\partial r}{\partial p_j} \quad (2-53)$$

A dissipation function will exist when the stress-strain relations are a generalization of the one-dimensional relation³

$$\sigma = E(\epsilon + \beta \dot{\epsilon}) \quad (2-54)$$

If we introduce Equation 2-53 into 2-49, we obtain

$$\int (\nabla \cdot \sum + P) \cdot \frac{\partial \pi}{\partial p_j} dV = P_j - \frac{\partial U}{\partial p_j} - \frac{\partial R}{\partial p_j} \quad (2-55)$$

¹H. Jeffreys, Cartesian Tensors, 1931.

²See Green and Zerna, Theoretical Elasticity Oxford, 1954, section 2.6, p. 71. This assumption is closely related to the First Principle of Thermodynamics.

³A rational generalization of Equation 2-54 has been given by Enrico Volterra, On Elastic Continua with Hereditary Characteristics, Journal of Applied Mechanics, September 1951. See also Section 4.1.5, Equations 4-182 through 4-187 in this report.

Contrails

where

$$U = \int u dV \quad (2-56)$$

and

$$R = \int \pi dV \quad (2-57)$$

U is the total internal or strain energy of the system and R is Rayleigh's dissipation function.

To summarize, we have obtained the following

$$\begin{aligned} \int (\nabla \cdot \Sigma + P) \cdot \frac{\partial \pi}{\partial p_j} dV - \int e \frac{\partial^2 \pi}{\partial t^2} \cdot \frac{\partial \pi}{\partial p_j} dV & \quad (2-58) \\ = p_j - \frac{\partial U}{\partial p_j} - \frac{\partial R}{\partial p_j} - \frac{d}{dt} \left(\frac{\partial T}{\partial p_j} \right) + \frac{\partial T}{\partial p_j} \end{aligned}$$

where

$$p_j = \int P \cdot \frac{\partial \pi}{\partial p_j} dV + \iint \frac{\partial \pi}{\partial p_j} \cdot \Sigma \cdot dS \quad (2-59)$$

$$U = \int u dV \quad (2-60)$$

$$R = \int \pi dV \quad (2-61)$$

$$T = \frac{1}{2} \int e \frac{\partial \pi}{\partial t} \cdot \frac{\partial \pi}{\partial t} dV \quad (2-62)$$

If we introduce this into Equation 2-40, we obtain

$$\delta W = \sum_{j=1}^N \left(p_j - \frac{\partial U}{\partial p_j} - \frac{\partial R}{\partial p_j} - \frac{d}{dt} \left(\frac{\partial T}{\partial p_j} \right) + \frac{\partial T}{\partial p_j} \right) \delta p_j = 0 \quad (2-63)$$

Contrails

We have assumed the p_j to be independent and the δp_j can be arbitrarily assigned, so that the only way the above sum can be zero is for each of the coefficients of the δp_j to be individually zero. The result is Lagrange's equations

$$\frac{d}{dt} \left(\frac{\partial T}{\partial \dot{p}_j} \right) - \frac{\partial T}{\partial p_j} + \frac{\partial U}{\partial p_j} + \frac{\partial R}{\partial p_j} = P_j \quad (2-64)$$

$$i = 1, 2, \dots, N$$

If part of the external body forces, P , is conservative, it too may be derived from a potential function. For example, if

$$\nabla \times P = 0 \quad (2-65)$$

then there exists a potential per unit volume, φ , such that

$$P = -\nabla \varphi \quad (2-66)$$

(Note, ∇ is the Eulerian gradient)

and we have

$$\begin{aligned} P_j &= \int P \cdot \frac{\partial \pi}{\partial p_j} dV & (2-67) \\ &= - \int \nabla \varphi \cdot \frac{\partial \pi}{\partial p_j} dV \\ &= - \int \frac{\partial \varphi}{\partial p_j} dV \\ &= - \frac{\partial V}{\partial p_j} \end{aligned}$$

Constraints

where

$$V(p_1, p_2 \dots p_N) = \int \theta dV \quad (2-68)$$

A typical example of such a force is the force of gravity.

2.1.2.2 Lagrange's Equations for a Redundant Set of Generalized Coordinates

If there is occasion to express the virtual work in terms of M generalized coordinates ($M > N$, the number of degrees-of-freedom), then

$$\delta W = \sum_{j=1}^M \left(P_j - \frac{\partial U}{\partial p_j} - \frac{\partial R}{\partial \dot{p}_j} - \frac{d}{dt} \left(\frac{\partial T}{\partial \dot{p}_j} \right) + \frac{\partial T}{\partial p_j} \right) \delta p_j = 0 \quad (2-69)$$

The p_j form a set of independent generalized coordinates only if $M = N$. If $M > N$, we must recognize that $M-N$ relations exist between these M coordinates which insure that the constraints are not violated

$$F_i(p_1, p_2 \dots p_M) = 0$$

$$i = 1, 2 \dots M-N$$

(2-70)

Since the p_j are not independent, we are not permitted to imply that the coefficients of δp_j in Equation 2-69 are zero. We may, instead, use Lagrange's method of undetermined multipliers. The derivation of Lagrange's equations in this case proceeds as follows.

The notion that the virtual displacements are consistent with the constraints is expressed by

$$F_i(p_1 + \delta p_1, p_2 + \delta p_2, \dots p_M + \delta p_M) = 0 \quad (2-71)$$

$$i = 1, 2 \dots M-N$$

Again, using the differential nature of virtual displacements, we obtain

$$\sum_{j=1}^M \frac{\partial F_i}{\partial p_j} \delta p_j = 0 \quad (2-72)$$

Contrails

If we introduce arbitrary multipliers, λ_i , we may also say that

$$\lambda_i \sum_{j=1}^M \frac{\partial F_i}{\partial p_j} \delta p_j = 0 \quad (2-73)$$

It is equally true that

$$\sum_{i=1}^{M-N} \sum_{j=1}^M \lambda_i \frac{\partial F_i}{\partial p_j} \delta p_j = 0 \quad (2-74)$$

If we add this zero-term to δW , we have

$$\begin{aligned} \delta W = & \sum_{j=1}^M \left(p_j - \frac{\partial U}{\partial p_j} - \frac{\partial R}{\partial p_j} - \frac{d}{dt} \left(\frac{\partial T}{\partial \dot{p}_j} \right) + \frac{\partial T}{\partial p_j} \right) \delta p_j \\ & + \sum_{j=1}^M \sum_{i=1}^{M-N} \lambda_i \frac{\partial F_i}{\partial p_j} \delta p_j = 0 \end{aligned} \quad (2-75)$$

We may choose values of λ_i that insure that the first $M-N$ coefficients of δp_j are zero; that is

$$p_j - \frac{\partial U}{\partial p_j} - \frac{\partial R}{\partial p_j} - \frac{d}{dt} \left(\frac{\partial T}{\partial \dot{p}_j} \right) + \frac{\partial T}{\partial p_j} + \sum_{i=1}^{M-N} \lambda_i \frac{\partial F_i}{\partial p_j} = 0 \quad (2-76)$$

$$j = 1, 2, \dots, M-N$$

The last N δp_j 's can be independently chosen so that

$$\sum_{j=M-N+1}^M \left(p_j - \frac{\partial U}{\partial p_j} - \frac{\partial R}{\partial p_j} - \frac{d}{dt} \left(\frac{\partial T}{\partial \dot{p}_j} \right) + \frac{\partial T}{\partial p_j} + \sum_{i=1}^{M-N} \lambda_i \frac{\partial F_i}{\partial p_j} \right) \delta p_j = 0 \quad (2-77)$$

implies

$$p_j - \frac{\partial U}{\partial p_j} - \frac{\partial R}{\partial p_j} - \frac{d}{dt} \left(\frac{\partial T}{\partial \dot{p}_j} \right) + \frac{\partial T}{\partial p_j} + \sum_{i=1}^{M-N} \lambda_i \frac{\partial F_i}{\partial p_j} = 0 \quad (2-78)$$

$$j = M-N+1, \dots, N$$

Equations 2-76 and 2-78 can very simply be written together as

$$\frac{d}{dt} \left(\frac{\partial T}{\partial \dot{p}_j} \right) - \frac{\partial T}{\partial p_j} + \frac{\partial U}{\partial p_j} + \frac{\partial R}{\partial p_j} = p_j + \sum_{i=1}^{M-N} \lambda_i \frac{\partial F_i}{\partial p_j} \quad (2-79)$$

$$F_i(p_1, p_2, \dots, p_M) = 0 \quad (2-80)$$

$$j = 1, 2, \dots, M$$

$$i = 1, 2, \dots, M-N$$

This is the form of Lagrange's equations which must be used when the generalized coordinates do not satisfy the constraints explicitly. It constitutes a set of $2M-N$ equations in the M redundant coordinates and the $M-N$ multipliers, λ_i .

2.1.2.3 Lagrange's Equations for Quasi-Coordinates

Occasionally in dynamics it is desirable to work with the kinetic energy expressed in terms of nonintegrable velocity components. For example, the kinetic energy of a rigid body can be expressed in terms of the velocity components of the mass-center referred to an axis system fixed in the body. Such considerations lead one to assume that the kinetic energy can be expressed in terms of N quantities, v_i , which are related to generalized coordinates for the system, by equations of the form

$$v_i = \sum_{j=1}^N a_{ij}(p_1, p_2, \dots, p_N) \dot{p}_j \quad (2-81)$$

An example is given by the motion of a rigid body in a plane. In this case we have

$$T = \frac{1}{2} (M v_1^2 + M v_2^2 + I v_3^2) \quad (2-82)$$

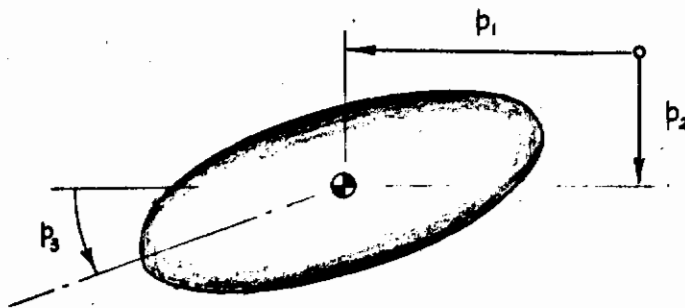

FIGURE 6 RIGID BODY IN PLANE MOTION

Contrails

In this expression v_1 and v_2 are the components of the velocity vector referred to principal axes. They are related to the generalized coordinates, p_1 , p_2 , and p_3 by

$$\begin{aligned}v_1 &= \cos p_3 \dot{p}_1 + \sin p_3 \dot{p}_2 \\v_2 &= -\sin p_3 \dot{p}_1 + \cos p_3 \dot{p}_2 \\v_3 &= \dot{p}_3\end{aligned}\tag{2-83}$$

which is the same form as that indicated in Equation 2-81. This example is also characterized by the fact that the set of first order equations, 2-83, are not integrable. That is, there does not exist a set of coordinates, s_1 , s_2 , and s_3 such that

$$\begin{aligned}v_1 &= \dot{s}_1 \\v_2 &= \dot{s}_2 \\v_3 &= \dot{s}_3\end{aligned}\tag{2-84}$$

To illustrate the point, the following similar set of equations is integrable in the above sense

$$\begin{aligned}v_1 &= \cos p_2 \dot{p}_1 - p_1 \sin p_2 \dot{p}_2 \\v_2 &= \sin p_2 \dot{p}_1 + p_1 \cos p_2 \dot{p}_2 \\v_3 &= \dot{p}_3\end{aligned}\tag{2-85}$$

It is easily verified, in fact, that in this case $v_1 = \dot{s}_1$ where

$$\begin{aligned}s_1 &= p_1 \cos p_2 \\s_2 &= p_1 \sin p_2 \\s_3 &= p_3\end{aligned}\tag{2-86}$$

which corresponds to a simple change from one set of generalized coordinates to another set of generalized coordinates. Our interests are specifically directed toward the case when the equations are nonintegrable.

In the general case we suppose that v_1 is one of a number of variables that may be appropriate for the description of the motion of a dynamical system. In particular we assume that

$$T = T(v_1, v_2, \dots, v_N; p_1, p_2, \dots, p_N)\tag{2-87}$$

Contrails

where

$$v_i = \sum_{j=1}^N \alpha_{ij} \dot{p}_j \quad (2-88)$$

Further, we suppose that $v_i dt$ is not an exact differential (i.e., there do not exist s_i , such that $ds_i = v_i dt$). It follows from this that

$$\frac{\partial \alpha_{ij}}{\partial p_k} = \frac{\partial \alpha_{kj}}{\partial p_i} \quad (2-89)$$

does not generally hold for all i, j , and k . (It can be shown that Equations 2-89 are necessarily true if s_i exists such that

$$\dot{s}_i = \sum_{j=1}^N \alpha_{ij} \dot{p}_j \quad (2-90)$$

If Equations 2-89 were true, our considerations here would reduce to a trivial change from one set of generalized coordinates to another.

In the nonintegrable case it is convenient to introduce the notion of a quasi-coordinate. The differentials of the quasi-coordinates are defined by

$$\delta s_i = \sum_{j=1}^N \alpha_{ij} \delta p_j \quad (2-91)$$

The quantity, δs_i , thus defined is not an exact differential and the existence of s_i is not implied by Equation 2-91.

If we can solve for \dot{p}_j in Equation 2-88, then

$$\dot{p}_j = \sum_{i=1}^N \beta_{ij} v_i \quad (2-92)$$

where α_{ij} are the elements in the inverse of the N by N matrix whose elements are β_{kj} . It follows that

$$\sum_{k=1}^N \alpha_{ik} \beta_{kj} = 1_{ij} = \begin{cases} 1 & i=j \\ 0 & i \neq j \end{cases} \quad (2-93)$$

Contrails

If we premultiply Lagrange's equations (Equation 2-64) by β_{ji} and sum over j , we obtain

$$\sum_{j=1}^N \beta_{ji} \left(\frac{d}{dt} \left(\frac{\partial T}{\partial \dot{p}_j} \right) - \frac{\partial T}{\partial p_j} \right) = \sum_{j=1}^N \beta_{ji} \left(P_j - \frac{\partial U}{\partial p_j} - \frac{\partial R}{\partial \dot{p}_j} \right) \quad (2-94)$$

The right-hand side is termed the "generalized forces associated with the quasi-coordinates." This follows from the fact that

$$S_i = \sum_{j=1}^N \beta_{ji} \left(P_j - \frac{\partial U}{\partial p_j} - \frac{\partial R}{\partial \dot{p}_j} \right) \quad (2-95)$$

is the coefficient of δs_j in the expression for the virtual work of the applied forces

$$\delta W = \sum_{j=1}^N \delta p_j \left(P_j - \frac{\partial U}{\partial p_j} - \frac{\partial R}{\partial \dot{p}_j} \right) = \sum_{i=1}^N \delta s_i \sum_{j=1}^N \beta_{ji} \left(P_j - \frac{\partial U}{\partial p_j} - \frac{\partial R}{\partial \dot{p}_j} \right) \quad (2-96)$$

where use has been made of Equation 2-91 to write

$$\delta p_j = \sum_{i=1}^N \beta_{ji} \delta s_i \quad (2-97)$$

To express Equations 2-94 in terms of the v_k , we note that

$$\frac{\partial T}{\partial \dot{p}_j} = \sum_{k=1}^N \frac{\partial T}{\partial v_k} \frac{\partial v_k}{\partial \dot{p}_j} \quad (2-98)$$

and

$$\frac{\partial T}{\partial p_j} = \sum_{k=1}^N \frac{\partial T}{\partial v_k} \frac{\partial v_k}{\partial p_j} + \frac{\partial T}{\partial p_j} \quad (2-99)$$

In these relations we may use Equation 2-88 to write

$$\frac{\partial v_k}{\partial \dot{p}_j} = \alpha_{kj} \quad (2-100)$$

Contrails

and

$$\frac{\partial v_k}{\partial p_j} = \sum_{l=1}^N \frac{\partial \alpha_{kl}}{\partial p_j} \dot{p}_l = \sum_{l=1}^N \sum_{n=1}^N \frac{\partial \alpha_{kl}}{\partial p_j} \theta_{ln} v_n \quad (2-101)$$

Substituting these into Equations 2-98 and 2-99, we obtain

$$\frac{\partial T}{\partial p_j} = \sum_{k=1}^N \frac{\partial T}{\partial v_k} \alpha_{kj} \quad (2-102)$$

$$\frac{\partial T}{\partial p_j} = \sum_{k=1}^N \sum_{l=1}^N \sum_{n=1}^N \frac{\partial T}{\partial v_k} \frac{\partial \alpha_{kl}}{\partial p_j} \theta_{ln} v_n + \frac{\partial T}{\partial p_j} \quad (2-103)$$

Substituting into Equations 2-94, we find that

$$\sum_{j=1}^N \beta_{ji} \sum_{k=1}^N \sum_{l=1}^N \sum_{n=1}^N \left(\alpha_{kj} \frac{d}{dt} \left(\frac{\partial T}{\partial v_k} \right) + \frac{\partial T}{\partial v_k} \left(\frac{\partial \alpha_{kj}}{\partial p_l} - \frac{\partial \alpha_{kl}}{\partial p_j} \right) \theta_{ln} v_n - \frac{\partial T}{\partial p_j} \right) = S_i \quad (2-104)$$

This can be simplified by using Equation 2-93

$$\frac{d}{dt} \left(\frac{\partial T}{\partial v_i} \right) - \sum_{j=1}^N \sum_{k=1}^N \sum_{l=1}^N \sum_{n=1}^N \left(\theta_{ki} \left(\frac{\partial \alpha_{jl}}{\partial p_k} - \frac{\partial \alpha_{jk}}{\partial p_l} \right) \theta_{ln} v_n \frac{\partial T}{\partial v_j} + \beta_{ji} \frac{\partial T}{\partial p_j} \right) = S_i \quad (2-105)$$

A further simplification results if the following definition is made

$$\Omega_{ij} = \sum_{k=1}^N \sum_{l=1}^N \sum_{n=1}^N \theta_{ki} \left(\frac{\partial \alpha_{jl}}{\partial p_k} - \frac{\partial \alpha_{jk}}{\partial p_l} \right) \theta_{ln} v_n \quad (2-106)$$

Contrails

We then have

$$\frac{d}{dt} \left(\frac{\partial T}{\partial v_i} \right) - \sum_{j=1}^N \Omega_{ij} \frac{\partial T}{\partial v_j} - \sum_{j=1}^N \Theta_{ji} \frac{\partial T}{\partial p_j} = S_i \quad (2-107)$$

It is interesting to note that in the case where Equations 2-88 are integrable we may use Equations 2-89 and 2-90 to write

$$\Omega_{ij} = 0 \quad (2-108)$$

and

$$\sum_{j=1}^N \Theta_{ji} \frac{\partial T}{\partial p_j} = \frac{\partial T}{\partial s_i} \quad (2-109)$$

and

$$v_i = \dot{s}_i \quad (2-110)$$

with the result that Equations 2-107 reduce to

$$\frac{d}{dt} \left(\frac{\partial T}{\partial \dot{s}_i} \right) - \frac{\partial T}{\partial s_i} = S_i \quad (2-111)$$

where

$$SW = \sum_{i=1}^N \delta s_i S_i \quad (2-112)$$

These are the Lagrange equations corresponding to the generalized coordinates, s_i , $i = 1, 2, \dots, N$.

Equations 2-107 have been called "Lagrange's equations for quasi-coordinates" by Whittaker¹. The coefficients, Ω_{ij} , depend only on the relation between v_i and the generalized coordinates. They are generally dependent, explicitly, only on the v_i .

¹Whittaker, A Treatise on the Analytical Dynamics of Particles and Rigid Bodies, Cambridge, 1961, p. 41.

2.2 THE GENERAL THEORY OF SMALL MOTIONS ABOUT A POINT OF MINIMUM POTENTIAL

The theory of vibrations which is the subject of this section plays an extremely important part in the methods of dynamic analysis which have been developed for elastic airframes and spacecraft. The generality of the concept of a mode of vibration is often obscured by fixing attention on special problems like beams and plates. It is possible, as we shall show, to introduce the theory of vibrations as a very general application of the fundamental principles of Analytical Mechanics. More specifically, we shall specialize the general principles of the preceding section by making the following assumptions:

1. The system has a finite number of degrees-of-freedom.
2. The system has a static or indifferent position of equilibrium when the external forces are zero.
3. There are no time dependent constraints (we assume this for simplicity only; actually, the theory we consider here can be generalized to include time dependent constraints.)
4. The displacements of the system from the equilibrium position are small in the sense that third order terms are negligible in comparison with quadratic terms.

With no essential loss in generality we shall assume that the position of equilibrium is given by

$$p_i = 0 \quad (2-113)$$

$$i = 1, 2, \dots, M$$

This is equivalent to saying that Lagrange's equations in the static case with no external forces (see Equation 2-64),

$$\frac{\partial U}{\partial p_i} = 0 \quad (2-114)$$

are satisfied by $p_i = 0$; that is,

$$\frac{\partial U}{\partial p_i} (0, 0, \dots, 0) = 0 \quad (2-115)$$

Because Equation 2-115 is a necessary condition for U having a minimum (actually a stationary) value, it is commonly said that $p_i = 0$ (in this case) is a "point of minimum potential."

2.2.1 The Kinetic and Potential Energies

If we denote the velocity of the x-y-z-particle by \mathcal{V} , then

$$\mathcal{V} = \frac{\partial \mathcal{M}}{\partial t}$$

Contrails

and the kinetic energy (Equation 2-62) is

$$T = \frac{1}{2} \int e v^2 dV \quad (2-116)$$

We want to show first that the kinetic energy is quadratic in the "generalized velocities," \dot{p}_j . We have, by differentiating Equation 2-37,

$$v = \sum_{j=1}^N \frac{\partial \pi}{\partial p_j} \dot{p}_j + \frac{\partial \pi}{\partial t} \quad (2-117)$$

The second term is zero if there are no time dependent constraints (assumption 3) because, in that case, time does not appear explicitly in Equation 2-37.

If we introduce Equation 2-117 into Equation 2-116, we obtain

$$T = \frac{1}{2} \int \sum_{i=1}^N \sum_{j=1}^N e \frac{\partial \pi}{\partial p_i} \cdot \frac{\partial \pi}{\partial p_j} \dot{p}_i \dot{p}_j dV \quad (2-118)$$

Integration and summation may be interchanged to obtain

$$T = \frac{1}{2} \sum_{i=1}^N \sum_{j=1}^N \int \frac{\partial \pi}{\partial p_i} \cdot \frac{\partial \pi}{\partial p_j} e dV \dot{p}_i \dot{p}_j \quad (2-119)$$

If we introduce

$$a_{ij}(p_1, p_2, \dots, p_N) = \int \frac{\partial \pi}{\partial p_i} \cdot \frac{\partial \pi}{\partial p_j} e dV \quad (2-120)$$

then

$$T = \frac{1}{2} \sum_{i=1}^N \sum_{j=1}^N a_{ij} \dot{p}_i \dot{p}_j \quad (2-121)$$

The generalized coordinates can generally be chosen so that

$$\frac{\partial \pi}{\partial p_i} = \text{a constant, independent of the } p_i. \quad (2-122)$$

Contrails

In this case, the a_{ij} are constants.

We have thus shown that the kinetic energy is a homogeneous quadratic expression in the generalized velocities. Note from Equation 2-120 that

$$a_{ij} = a_{ji} \quad (2-123)$$

Considering now the potential strain energy¹, we want to show that under assumptions 2 and 4 the strain energy is also a quadratic form. To do this we expand the strain energy in an N-dimensional Taylor's series about the point of equilibrium, $p_i = 0$.

$$U(p_1, p_2, \dots, p_N) = U(0, 0, \dots, 0) + \sum_{i=1}^N \frac{\partial U}{\partial p_i}(0, 0, \dots, 0) p_i + \frac{1}{2!} \sum_{i=1}^N \sum_{j=1}^N \frac{\partial^2 U}{\partial p_i \partial p_j}(0, 0, \dots, 0) p_i p_j + \dots \quad (2-124)$$

If the arbitrary reference for the potential is taken as zero at the equilibrium position, then

$$U(0, 0, \dots, 0) = 0 \quad (2-125)$$

Also, from Equation 2-115,

$$\frac{\partial U}{\partial p_i}(0, 0, \dots, 0) = 0 \quad (2-126)$$

Further, if we invoke assumption 4 and neglect terms in the series that are of a higher order than the quadratic terms, $p_i p_j$, then

$$U = \frac{1}{2} \sum_{i=1}^N \sum_{j=1}^N \frac{\partial^2 U}{\partial p_i \partial p_j}(0, 0, \dots, 0) p_i p_j \quad (2-127)$$

¹If part of the external forces is conservative, then their potential may also be included. For example, gravity forces are important to the vibration of a pendulum.

Contrails

If we introduce

$$k_{ij} = \frac{\partial^2 U}{\partial p_i \partial p_j} (0, 0, \dots, 0) \quad (2-128)$$

then the strain energy for small motions is

$$U = \frac{1}{2} \sum_{i=1}^N \sum_{j=1}^N k_{ij} p_i p_j \quad (2-129)$$

Since U is continuous and otherwise well-behaved at $p_i = 0$, we must have

$$\frac{\partial^2 U}{\partial p_i \partial p_j} = \frac{\partial^2 U}{\partial p_j \partial p_i} \quad (2-130)$$

Consequently,

$$k_{ij} = k_{ji} \quad (2-131)$$

Using the definition of matrix algebra, we can write Equation 2-121 and Equation 2-129 as

$$T = \frac{1}{2} \{ \dot{p} \}' [A] \dot{p} \quad (2-132)$$

and

$$U = \frac{1}{2} \{ p \}' [K] p \quad (2-133)$$

where $[A]$ is the N by N matrix of inertia coefficients, a_{ij} , and $[K]$ is the N by N matrix of stiffness coefficients, k_{ij} . It follows from Equations 2-123 and 2-131 that the inertia matrix and stiffness matrix are symmetric matrices, that is

$$[A]' = [A] \quad (2-134)$$

and

$$[K]' = [K] \quad (2-135)$$

In Equations 2-132 and 2-133, $\{p\}$ is a column matrix of the N generalized coordinates, p_j , $j = 1, 2, \dots, N$.

$$\{p\} = \begin{bmatrix} p_1 \\ p_2 \\ \vdots \\ p_N \end{bmatrix} \quad (2-136)$$

2.2.2 The Equations of Motion

We may employ Lagrange's equations (Equation 2-64) to derive the equations governing the motion of the system described by Equations 2-132 and 2-133. It can be shown that in the case where $\dot{p}_i \dot{p}_j \gg \dot{p}_i \dot{p}_j \dot{p}_k$ (in addition to assumptions 1 thru 4), the Rayleigh dissipation function can be approximated by

$$R = \frac{1}{2} \sum_{i=1}^N \sum_{j=1}^N b_{ij} \dot{p}_i \dot{p}_j = \frac{1}{2} \{\dot{p}\}' [B] \dot{p} \quad (2-137)$$

where the elements, b_{ij} , of the damping matrix, $[B]$, are constants. Also, the existence and continuity of the dissipation function in the neighborhood of the equilibrium position ($p_j = 0$) require that

$$[B]' = [B] \quad (2-138)$$

The virtual work δW of the external forces defines the generalized forces, P_j , associated with the generalized coordinates, p_j (see Equation 2-48).

$$\delta W = \sum_{j=1}^N \delta p_j P_j = \{\delta p\}' \{P\} \quad (2-139)$$

Substituting Equations 2-132, 2-133, and 2-137 into Equation 2-64 using 2-139, we obtain

$$[A] \ddot{p} + [B] \dot{p} + [K] p = \{P\} \quad (2-140)$$

where use has been made of the fact that

$$\frac{\partial T}{\partial \dot{p}_k} = \frac{1}{2} \sum_{i=1}^N \sum_{j=1}^N a_{ij} \frac{\partial (\dot{p}_i \dot{p}_j)}{\partial \dot{p}_k} = \sum_{j=1}^N a_{kj} \dot{p}_j \quad (2-141)$$

$$\frac{\partial I}{\partial p_R} = 0 \quad (2-142)$$

$$\frac{\partial U}{\partial p_R} = \frac{1}{2} \sum_{i=1}^N \sum_{j=1}^N k_{ij} \frac{\partial (p_i p_j)}{\partial p_R} = \sum_{j=1}^N k_{Rj} p_j \quad (2-143)$$

$$\frac{\partial R}{\partial \dot{p}_R} = \frac{1}{2} \sum_{i=1}^N \sum_{j=1}^N \epsilon_{ij} \frac{\partial (\dot{p}_i \dot{p}_j)}{\partial \dot{p}_R} = \sum_{j=1}^N \epsilon_{Rj} \dot{p}_j \quad (2-144)$$

Equations 2-140 are the classical equations of the theory of vibrations that were first derived by Lagrange and subsequently studied by Lord Rayleigh.

2.2.3 General Solutions to the Vibration Equations

2.2.3.1 The Homogeneous Equations of Free Vibration

We will first consider the case of free vibrations with no damping because of the importance these solutions have in the cases where $\{P\} \neq \{0\}$ and dissipation is present. We will consider then

$$[A]\ddot{\{p\}} + [K]\{p\} = \{0\} \quad (2-145)$$

These equations are a linear simultaneous set of coupled second-order differential equations. We may find a solution to these equations by assuming a "product" solution of the form

$$\{p(t)\} = \{\phi\} q(t) \quad (2-146)$$

where the elements of $\{\phi\}$ are not functions of time. Substituting this into Equation 2-145, we obtain

$$[A]\{\phi\} \ddot{q} + [K]\{\phi\} q = \{0\} \quad (2-147)$$

or

$$[A]\{\phi\} = -\frac{q}{\ddot{q}} [K]\{\phi\} \quad (2-148)$$

Contrails

Since the left side of the equation is independent of time, the right side must be also, so that

$$-\frac{\ddot{q}}{q} = \lambda = \text{a constant} \quad (2-149)$$

Equations 2-145 have then been "separated" into the equations

$$([A] - \lambda [K])\{\phi\} = \{0\} \quad (2-150)$$

and

$$\ddot{q} + \frac{1}{\lambda} q = 0 \quad (2-151)$$

In order that solutions (other than the trivial one, $\{\phi\} = \{0\}$) exist, it is necessary that the determinant of the coefficients in Equation 2-150 be zero

$$\Delta(\lambda) = |[A] - \lambda [K]| = 0 \quad (2-152)$$

This equation is an N^{th} order polynomial in λ which determines N discrete values of λ for which a product solution of the form in Equation 2-146 exists. It can be shown that, due to the symmetry properties of $[A]$ and $[K]$, the roots, λ_i , of $\Delta(\lambda) = 0$ are all real; and, further, they are positive because of the positive definite character of $[A]$ and $[K]$. For each of the N roots there corresponds a solution to Equation 2-150.

$$([A] - \lambda_i [K])\{\phi\}_i = \{0\} \quad (2-153)$$

It may be noted that any constant multiple of a solution is also a solution. To make the solution unique, an arbitrary normalizing condition can be imposed. Most often it is convenient to assume that

$$\{\phi\}_i^T [A] \{\phi\}_i = 1 \quad (2-154)$$

It is evident that if $\{\phi\}_i$ is any solution to Equation 2-153, then

$$\left(\frac{1}{\sqrt{\{\phi\}_i^T [A] \{\phi\}_i}} \right) \{\phi\}_i \quad (2-155)$$

Contrails

is a normalized solution; that is, one that satisfies Equation 2-154 as well as Equation 2-153.

Solutions to Equation 2-151 for each λ_i are

$$q_i(t) = a_i \cos \omega_i t + b_i \sin \omega_i t \quad (2-156)$$

where

$$\omega_i = \frac{1}{\sqrt{\lambda_i}} \quad (2-157)$$

By a theorem of linear differential equations the general solution to the homogeneous equations (Equation 2-145) is a linear combination of the N particular solutions,

$$\{\varphi\}_i q_i(t) \quad (2-158)$$

$$i = 1, 2, \dots, N$$

$$\{p(t)\} = \sum_{i=1}^N \{\varphi\}_i (a_i \cos \omega_i t + b_i \sin \omega_i t) \quad (2-159)$$

The constants, a_i and b_i , can be expressed in terms of initial conditions; but we will postpone this until the "orthogonality" relations are established.

2.2.3.2 Orthogonality Relations for the Modal Columns

Any two different solutions to Equation 2-150 corresponding to λ_i and λ_j ($i \neq j$) must satisfy

$$[A]\{\varphi\}_i = [K]\{\varphi\}_i \lambda_i \quad (2-160)$$

and

$$[A]\{\varphi\}_j = [K]\{\varphi\}_j \lambda_j \quad (2-161)$$

If we premultiply the first equation by $\{\varphi\}'_j$ and the second equation by $\{\varphi\}'_i$ then transpose the first equation, we obtain

$$\{\varphi\}'_i [A]\{\varphi\}_j = \{\varphi\}'_i [K]\{\varphi\}_j \lambda_i \quad (2-162)$$

Contrails

$$\{\varphi\}'_i [A] \{\varphi\}_j = \{\varphi\}'_i [K] \{\varphi\}_j \lambda_j \quad (2-163)$$

If Equation 2-162 is subtracted from Equation 2-163 and we note that $[A]' = [A]$ and $[K]' = [K]$, then

$$\{\varphi\}'_i [K] \{\varphi\}_j (\lambda_i - \lambda_j) = 0 \quad (2-164)$$

Since $i \neq j$, $\lambda_i - \lambda_j \neq 0$ so long as there are no repeated roots to the characteristic equation, $\Delta(\lambda) = 0$. Our discussion here will apply to the case of no repeated roots; however, some practical systems can have repeated roots although they usually present no problem.

If $\lambda_i - \lambda_j \neq 0$, then

$$\{\varphi\}'_i [K] \{\varphi\}_j = 0 \quad (2-165)$$

and from Equation 2-162

$$\{\varphi\}'_i [A] \{\varphi\}_j = 0 \quad (2-166)$$

If we premultiply Equation 2-160 by $\{\varphi\}'_i$, we obtain

$$\{\varphi\}'_i [K] \{\varphi\}_i = \frac{1}{\lambda_i} \{\varphi\}'_i [A] \{\varphi\}_i \quad (2-167)$$

Using Equation 2-154, we get

$$\{\varphi\}'_i [K] \{\varphi\}_i = \frac{1}{\lambda_i} = \omega_i^2 \quad (2-168)$$

In summary, the orthogonality relations are

$$\{\varphi\}'_i [A] \{\varphi\}_j = \begin{cases} 1 & i=j \\ 0 & i \neq j \end{cases} \quad (2-169)$$

$$\{\varphi\}'_i [K] \{\varphi\}_j = \begin{cases} \frac{1}{\lambda_i} & i=j \\ 0 & i \neq j \end{cases} \quad (2-170)$$

Contrails

In Equation 2-159 we may use the above equations to express the arbitrary constants, a_i and b_i , in terms of the initial values of the generalized coordinates and generalized velocities. Setting $t = 0$ in Equation 2-159, we get

$$\{p(0)\} = \sum_{i=1}^N \{\varphi\}_i a_i \quad (2-171)$$

and similarly

$$\{\dot{p}(0)\} = \sum_{i=1}^N \{\varphi\}_i b_i \omega_i \quad (2-172)$$

To solve for a_i and b_i , we premultiply by $\{\varphi\}'_j [A]$

$$\{\varphi\}'_j [A] \{p(0)\} = \sum_{i=1}^N \{\varphi\}'_j [A] \{\varphi\}_i a_i \quad (2-173)$$

$$\{\varphi\}'_j [A] \{\dot{p}(0)\} = \sum_{i=1}^N \{\varphi\}'_j [A] \{\varphi\}_i b_i \omega_i \quad (2-174)$$

Using the orthogonality relations (Equation 2-169 and 2-170), these simplify to

$$a_i = \{\varphi\}'_i [A] \{p(0)\} \quad (2-175)$$

$$b_i = \frac{1}{\omega_i} \{\varphi\}'_i [A] \{\dot{p}(0)\} \quad (2-176)$$

We obtain the complete solution to the homogeneous equations of free vibration by substituting Equations 2-175 and 2-176 into Equation 2-159.

$$\{p(t)\} = \sum_{i=1}^N \{\varphi\}_i \{\varphi\}'_i [A] \left(\{p(0)\} \cos \omega_i t + \{\dot{p}(0)\} \frac{\sin \omega_i t}{\omega_i} \right) \quad (2-177)$$

Finally, we conclude by noting that Equations 2-169 and 2-170 can be written concisely as

$$[\dot{\varphi}]' [A] [\varphi] = \{r_1\} \quad (2-178)$$

and

$$[\dot{\varphi}]' [K] [\varphi] = \{r_{1/\lambda}\} \quad (2-179)$$

where $[\phi]$ is the matrix of modal columns

$$[\varphi] = [\{\varphi\}_1, \{\varphi\}_2, \dots, \{\varphi\}_N] \quad (2-180)$$

commonly called the "modal matrix."

2.2.3.3 Response of the Undamped System to External Forces Which Are a Function of Time Only

In Equation 2-140 we assume, again, that $[B] = [0]$ but that the generalized forces, $\{P\}$, are a function of time explicitly.

$$[A] \{\ddot{p}\} + [K] \{p\} = \{P(t)\} \quad (2-181)$$

Let us assume as a solution, the series

$$\{p(t)\} = \sum_{i=1}^N \{\varphi\}_i q_i(t) \quad (2-182)$$

where the q_i are to be determined by the external forces. Equation 2-182 may also be written as

$$\{p(t)\} = [\varphi] \{q(t)\} \quad (2-183)$$

where $[\phi]$ is the modal matrix (Equation 2-180). The latter expression emphasizes the role of the q_i 's as coordinates to describe the motion of the system. Equation 2-183 is commonly called the normal coordinate transformation and the q_i 's are called normal coordinates. They are, in fact, a set of generalized coordinates which can be used to specify the configuration of the system in the same way the p_j 's do. The inverse transformation corresponding to Equation 2-183 can be obtained by premultiplying Equation 2-183 by $[\phi]'$ [A]

Contrails

$$[\varphi]'[A]\{p(t)\} = [\varphi]'[A][\varphi]\{q(t)\} \quad (2-184)$$

Using Equation 2-178, we have

$$\{q(t)\} = [\varphi]'[A]\{p(t)\} \quad (2-185)$$

Equations 2-181 are simplified when the q_i 's are used as generalized coordinates. To transform to normal coordinates let us substitute Equation 2-183 into Equation 2-181

$$[A][\varphi]\{\ddot{q}\} + [k][\varphi]\{q\} = \{P\} \quad (2-186)$$

We will transform the generalized forces consistently if we premultiply this equation by $[\varphi]'$

$$[\varphi]'[A][\varphi]\{\ddot{q}\} + [\varphi]'[k][\varphi]\{q\} = [\varphi]'\{P\} \quad (2-187)$$

Making use of Equations 2-178 and 2-179, we obtain

$$\{\ddot{q}\} + [\lambda]\{q\} = [\varphi]'\{P\} \quad (2-188)$$

The differential equations are uncoupled when expressed in normal coordinates. The i th equation is

$$\frac{d^2 q_i}{dt^2} + \lambda_i q_i = \{\varphi\}'_i \{P(t)\} \quad (2-189)$$

These differential equations may be solved by a variety of methods, but the Laplace transform has specific advantages in this case. We define

$$\bar{q}_i(s) = \int_0^{\infty} q_i(t) e^{-st} dt \quad (2-190)$$

Contrails

Operating on Equation 2-189, we obtain

$$s^2 \bar{q}_i(s) + \frac{1}{\lambda_i} \bar{q}_i(s) = \{\varphi\}'_i \{\bar{p}(s)\} + s q_i(0) + \dot{q}_i(0) \quad (2-191)$$

or

$$\bar{q}_i(s) = \frac{1}{s^2 + \omega_i^2} \{\varphi\}'_i \{\bar{p}(s)\} + \frac{s q_i(0) + \dot{q}_i(0)}{s^2 + \omega_i^2} \quad (2-192)$$

If we identify the following transforms

$$\int_0^{\infty} \cos \omega_i t e^{-st} dt = \frac{s}{s^2 + \omega_i^2} \quad (2-193)$$

$$\int_0^{\infty} \frac{\sin \omega_i t}{\omega_i} e^{-st} dt = \frac{1}{s^2 + \omega_i^2} \quad (2-194)$$

we can use the convolution theorem to write the solution

$$q_i(t) = \int_0^t \frac{\sin \omega_i(t-\tau)}{\omega_i} \{\varphi\}'_i \{P(\tau)\} d\tau + q_i(0) \cos \omega_i t + \dot{q}_i(0) \frac{\sin \omega_i t}{\omega_i} \quad (2-195)$$

Substituting into Equation 2-182 using Equation 2-185, we obtain

$$\begin{aligned} \{p(t)\} &= \sum_{i=1}^N \{\varphi\}_i \{\varphi\}'_i \int_0^t \frac{\sin \omega_i(t-\tau)}{\omega_i} \{P(\tau)\} d\tau \\ &+ \sum_{i=1}^N \{\varphi\}_i \{\varphi\}'_i [A] \left(\{p(0)\} \cos \omega_i t + \{\dot{p}(0)\} \frac{\sin \omega_i t}{\omega_i} \right) \end{aligned} \quad (2-196)$$

Contrails

The Green's function for the system is

$$[G(t)] = \sum_{i=1}^N \{\varphi\}_i \{\varphi\}'_i \frac{\sin \omega_i t}{\omega_i} \quad (2-197)$$

which has the property that the solution with zero initial energy is

$$\{p(t)\} = \int_0^t [G(t-\tau)] \{P(\tau)\} d\tau \quad (2-198)$$

The transform of the Green's function is the admittance matrix which, in this case, is

$$[H(s)] = \sum_{i=1}^N \frac{[\psi]_i}{s^2 + \omega_i^2} \quad (2-199)$$

where

$$[\psi]_i = \{\varphi\}_i \{\varphi\}'_i \quad (2-200)$$

It can also be shown that the admittance matrix has the property that

$$[H(s)] = ([A]s^2 + [K])^{-1} \quad (2-201)$$

2.2.3.4 The Zero-Frequency Modes of an Unrestrained System

All of the modes and frequencies must satisfy Equation 2-153 which may be written as

$$(-\omega_i^2 [A] + [K]) \{\varphi\}_i = \{0\} \quad (2-202)$$

Possible solutions for which $\omega_i = 0$ are called zero-frequency (or "rigid body") modes, and they must satisfy

$$[K] \{\varphi\}_i = \{0\} \quad (2-203)$$

Contrails

Modes which satisfy Equation 2-203 represent possible displacements for which the potential energy is zero. If

$$\{p\} = \{\varphi\}_i \quad (2-204)$$

where $\{\phi\}_i$ satisfies Equation 2-203, then

$$U = \frac{1}{2} \{p\}' [K] \{p\} = \frac{1}{2} \{p\}' ([K] \{\varphi\}_i) = 0 \quad (2-205)$$

These are then possible displacements which result in no elastic deformation. Thus, the term "rigid-body" modes.

In order that solutions other than the trivial one,

$$\{\varphi\}_i = \{0\} \quad (2-206)$$

exist, it is necessary that the determinant of the coefficients of $\{\phi\}_i$ be zero. That is

$$|[K]| = 0 \quad (2-207)$$

The stiffness matrix then is necessarily singular when there are rigid body modes. If we denote the rigid body modes by $\{\varphi_R\}_i$ and premultiply Equation 2-202 by $\{\varphi_R\}_j$, then

$$\omega_i^2 \{\varphi_R\}_j' [A] \{\varphi\}_i - \{\varphi_R\}_j' [K] \{\varphi\}_i = 0 \quad (2-208)$$

but

$$\{\varphi_R\}_j' [K] \{\varphi\}_i = \{\varphi\}_i' ([K] \{\varphi_R\}_j) = 0 \quad (2-209)$$

hence for $\omega_i \neq 0$,

$$\{\varphi_R\}_j' [A] \{\varphi\}_i = 0 \quad (2-210)$$

We thus conclude that all of the zero-frequency modes are orthogonal to the elastic modes for which $\omega_i \neq 0$.

Contrails

If the system is restrained so that the only possible displacements are ones for which the system is deformed and strain energy is stored, then rigid-body modes are not present and there are no solutions to Equation 2-202 corresponding to $\omega_i = 0$. In this case

$$|[K]| \neq 0 \quad (2-211)$$

and $[K]^{-1}$ exists. Lagrange's equations (Equation 2-64) in the static case give

$$\frac{\partial U}{\partial p_i} = P_i \quad (2-212)$$

or

$$[K]\{p\} = \{P\} \quad (2-213)$$

If there are no zero-frequency modes, then

$$\{p\} = [K]^{-1}\{P\} \quad (2-214)$$

which indicates that the displacements of an elastic system are linearly related to the loads acting on it (for small displacements). The matrix

$$[E] = [K]^{-1} \quad (2-215)$$

is called the influence matrix. The (i, j) element is the contribution to the i^{th} generalized coordinate by a unit value of the j^{th} generalized force.

$$p_i = \sum_{j=1}^N e_{ij} P_j \quad (2-216)$$

For a restrained system the strain energy may be expressed in terms of the applied loads acting on the system by using

$$\{p\} = [E]\{P\} \quad (2-217)$$

Contrails

$$\begin{aligned} U &= \frac{1}{2} \{p\}' [K] \{p\} \\ &= \frac{1}{2} \{p\}' [E] [K]^{-1} \{p\} \\ &= \frac{1}{2} \{p\}' [E] \{p\} \end{aligned} \quad (2-218)$$

From this, Castigliano's theorem is easily proven:

$$\frac{\partial U}{\partial p_i} = \sum_{j=1}^N e_{ij} p_j = p_i \quad (2-219)$$

For restrained systems, Equation 2-150 can be written as

$$\boxed{[E][A]\{\varphi\} = \lambda\{\varphi\}} \quad (2-220)$$

an expression which is suitable for a numerical solution by an iteration procedure. The practical importance of iterative procedures makes it desirable to derive a relation suitable for iteration of systems that are unrestrained. For such systems we have shown that $|[K]| = 0$ and thus $[E] = [K]^{-1}$ does not exist.

The essence of this problem can be posed as: Are there solutions to the static equations (Equations 2-213),

$$[K]\{p\} = \{p\} \quad (2-221)$$

even when $|[K]| = 0$ because of the unrestrained conditions?

From the theory of linear equations it is known that there are solutions to the set of equations, Equations 2-221, provided the right-hand side satisfies certain conditions. In particular, we note that the homogeneous equations,

$$[K]\{p\} = \{0\} \quad (2-222)$$

have a general solution which is a linear combination of all the distinct zero-frequency modes. That is,

$$\{p\} = \{\varphi_{R1}\} c_1 + \{\varphi_{R2}\} c_2 + \dots + \{\varphi_{RM}\} c_M, \quad (2-223)$$

Contrails

is a solution to Equations 2-222 for an arbitrary choice of the constants, c_1, c_2, \dots, c_M (where M is the number of zero-frequency modes).

Also, a theorem of the theory of linear equations states that the general solution to Equations 2-221 is the sum of the solution to the homogeneous equations (Equations 2-222) and a particular solution to the nonhomogeneous equations.

We will try to find a particular solution to Equations 2-221 in the form

$$[S]\{p^*\} \quad (2-224)$$

Let us then assume the general solution to be

$$\{p\} = \sum_{i=1}^M \{\varphi_R\}_i c_i + [S]\{p^*\} \quad (2-225)$$

and substitute this into Equations 2-221

$$[K] \left(\sum_{i=1}^M \{\varphi_R\}_i c_i + [S]\{p^*\} \right) = \{P\} \quad (2-226)$$

The definition of zero-frequency modes (Equation 2-203) gives

$$[K]\{\varphi_R\}_i = \{0\} \quad (2-227)$$

$$i = 1, 2, \dots, M$$

so that Equation 2-226 becomes

$$[K][S]\{p^*\} = \{P\} \quad (2-228)$$

It is evident that if these equations are to have a solution, then

$$\{\varphi_R\}'_i [K][S]\{p^*\} = \{\varphi_R\}'_i \{P\} \quad (2-229)$$

But the left side is zero from Equation 2-227; thus, it is necessary that

$$\{\varphi_R\}'_i \{P\} = 0 \quad (2-230)$$

$$i = 1, 2, \dots, M$$

Contrails

This is a condition which must be satisfied by $\{P\}$ in order that Equations 2-221 have a solution.

Assuming Equation 2-230 is true, we will attempt to obtain a solution to Equation 2-228 by premultiplying that equation by $[S]$.

$$[S]'[K][S]\{p\} = [S]\{P\} \quad (2-231)$$

Up to this point we have said very little about the matrix, $[S]'$. We now want to assume that $[S]$ is an $N \times N - M$ matrix, such that

$$[S]'[K][S] \quad (2-232)$$

is non-singular. It follows, that the columns of the $[S]$ -matrix must necessarily be linearly independent, but this is not sufficient to insure that Equation 2-232 is non-singular. A sufficient condition is provided by considering M arbitrary but independent constraints which would prevent rigid-body motion of the system. For a linear system these constraints can be expressed generally as

$$[L]\{p\} = \{0\} \quad (2-233)$$

We can pose a physical argument that at least M of the coordinates, p_j , $j = 1, 2, \dots, N$, must be involved in these constraints in such a way that there exist M columns of the $[L]$ -matrix that are linearly independent. If we assume that these columns appear as the first M columns of $[L]$, then

$$[\{L\}_1, \{L\}_2, \dots, \{L\}_M] \quad (2-234)$$

is a square, non-singular matrix. Stated differently, it is possible to partition Equations 2-233

$$[[L_1], [L_2]] \begin{Bmatrix} \{p_1\} \\ \{p_2\} \end{Bmatrix} = \{0\} \quad (2-235)$$

so that

$$\{p_1\} = -[L_1]^{-1}[L_2]\{p_2\} \quad (2-236)$$

Constraints

or

$$\{p\} = \begin{bmatrix} -[L_1]^{-1}[L_2] \\ \{1\} \end{bmatrix} \{p_2\} \quad (2-237)$$

The coefficient matrix in Equation 2-237 can be taken as an $[S]$ -matrix. If Equations 2-233 represent true constraints of rigid-body motion, it is physically evident that

$$[S]^{-1}[K][S] \quad \text{with} \quad [S] = \begin{bmatrix} -[L_1]^{-1}[L_2] \\ \{1\} \end{bmatrix} \quad (2-238)$$

is a stiffness matrix for the constrained system and hence should be non-singular.

A condition on $[S]$ which is sufficient but not necessary is that

$$[\varphi_R]'[S] = [0] \quad (2-239)$$

The proof that this is sufficient to insure that

$$[S]^{-1}[K][S] \quad (2-240)$$

is positive definite is long and involved and is omitted here. For completeness we note that an $[S]$ -matrix satisfying Equation 2-239 is easily constructed. For this purpose, partition $[\varphi_R]$ so that

$$[\varphi_R] = \begin{bmatrix} \text{---} \\ [\varphi_{R_1}] \\ [\varphi_{R_2}] \end{bmatrix} \quad (2-241)$$

and let

$$[S] = \begin{bmatrix} -[\varphi_{R_1}]^{-1}[\varphi_{R_2}] \\ \{1\} \end{bmatrix} \quad (2-242)$$

Contrails

We then have

$$[S]'[\varphi_R] = [\varphi_{R_2}][\varphi_{R_1}]^{-1}[\varphi_{R_1}] - [\varphi_{R_2}] = [0] \quad (2-243)$$

Returning to Equation 2-231, we have

$$\{p^*\} = ([S]'[K][S])^{-1}[S]'\{P\} \quad (2-244)$$

Substituting this into Equation 2-225, we obtain

$$\{p\} = \sum_{i=1}^M \{\varphi_{R_i}\} c_i + [S]([S]'[K][S])^{-1}[S]'\{P\} \quad (2-245)$$

which is the general solution to Equation 2-221 provided Equation 2-230 holds.

The matrix,

$$[E] = [S]([S]'[K][S])^{-1}[S]' \quad (2-246)$$

is a set of influence coefficients corresponding to some arbitrary constraint of the rigid-body motion. It is desirable for later discussions to express the c_i in Equation 2-245 in terms of the zero-frequency normal coordinates. This we proceed to do.

The general solution to the undamped vibration equations (Equations 2-145) is a linear combination of all the solutions to Equation 2-202 (including the modes corresponding to $\omega_i = 0$).

$$\{p(t)\} = \sum_{i=1}^M \{\varphi_{R_i}\} q_R^{(i)}(t) + \sum_{i=1}^{N-M} \{\varphi\}_i q_i(t) \quad (2-247)$$

If we premultiply this by $\{\phi_{R_j}\}'[A]$, then

$$\{\varphi_{R_j}\}'[A]\{p\} = \sum_{i=1}^M \{\varphi_{R_j}\}'[A]\{\varphi_{R_i}\} q_R^{(i)} \quad (2-248)$$

Contrails

where use has been made of Equation 2-210. If we introduce the matrix of zero-frequency modes

$$[\varphi_R] = [\{\varphi_{R1}\}, \{\varphi_{R2}\}, \dots, \{\varphi_{RM}\}] \quad (2-249)$$

then Equation 2-248 can be written as

$$[\varphi_R]'[A]\{p\} = [\varphi_R]'[A][\varphi_R]\{q_R\} \quad (2-250)$$

If we also premultiply Equation 2-245 by $[\varphi_R]'[A]$, then

$$[\varphi_R]'[A]\{p\} = [\varphi_R]'[A][\varphi_R]\{c\} + [\varphi_R]'[A][E]\{P\} \quad (2-251)$$

and

$$\{c\} = ([\varphi_R]'[A][\varphi_R])^{-1}[\varphi_R]'[A]\{p\} - ([\varphi_R]'[A][\varphi_R])^{-1}[\varphi_R]'[A][E]\{P\} \quad (2-252)$$

Substituting from Equation 2-250, we have

$$\{c\} = \{q_R\} - ([\varphi_R]'[A][\varphi_R])^{-1}[\varphi_R]'[A][E]\{P\} \quad (2-253)$$

Substituting this into Equation 2-245, we have

$$\{p\} = [\varphi_R]\{q_R\} + [E]\{P\} - [\varphi_R]([[\varphi_R]'[A][\varphi_R])^{-1}[\varphi_R]'[A][E]\{P\} \quad (2-254)$$

which can be simplified if we introduce the matrix

$$[\Gamma] = [I] - [A][\varphi_R]([[\varphi_R]'[A][\varphi_R])^{-1}[\varphi_R]'$$
 (2-255)

We then have

$$\{p\} = [\varphi_R]\{q_R\} + [\Gamma]'[E]\{P\} \quad (2-256)$$

Contrails

which is the general solution to the static equations,

$$[K]\{p\} = \{P\} \quad (2-257)$$

provided

$$[\varphi_R]'\{P\} = \{0\} \quad (2-258)$$

Many of the aeroelastic problems associated with unrestrained bodies are approximately solved by imposing the constraint,

$$\{q_R\} = \{0\} \quad (2-259)$$

so that the system can only take on a configuration that is a linear combination of its elastic modes,

$$\{p\} = \sum_{i=1}^{N-M} \{\varphi\}_i q_i \quad (2-260)$$

In particular, it is useful to impose this constraint in order to derive an equation governing only the elastic modes for the purpose of numerical solution. Equation 2-259 leads to the following conditions of constraint on the generalized coordinates, p_j ,

$$[\varphi_R]'\{A\}\{p\} = \{0\} \quad (2-261)$$

which follows by setting $\{q_R\} = \{0\}$ in Equation 2-250. If we recall that the kinetic and potential energy is

$$T = \frac{1}{2} \{\dot{p}\}'[A]\{\dot{p}\} \quad (2-262)$$

$$U = \frac{1}{2} \{p\}'[K]\{p\} \quad (2-263)$$

then we may use Lagrange's equations for coordinates which are not independent (Equation 2-79). The relations of constraint are

Constraints

$$F_i(p_1, p_2, \dots, p_N) = \{\varphi_R\}'_i [A] \{p\} = 0 \quad (2-264)$$

$$i = 1, 2, \dots, M$$

and the generalized constraint forces are

$$\sum_{i=1}^M \lambda_i \frac{\partial F_i}{\partial p_j} = \sum_{i=1}^M \lambda_i \frac{\partial}{\partial p_i} (\{\varphi_R\}'_i [A] \{p\}) \quad (2-265)$$

or

$$\left[\frac{\partial F}{\partial p} \right] \{ \lambda \} = [A] \{ \varphi_R \} \{ \lambda \} \quad (2-266)$$

Substituting this into Lagrange's equation, we obtain

$$[A] \{ \ddot{p} \} + [K] \{ p \} - [A] \{ \varphi_R \} \{ \lambda \} = \{ P \} \quad (2-267)$$

The Lagrangian multipliers, λ_i , may be eliminated by the following procedure. Premultiply Equation 2-267 by $[\varphi_R]'$.

$$[\varphi_R]' [A] \{ \ddot{p} \} + [\varphi_R]' [K] \{ p \} - [\varphi_R]' [A] \{ \varphi_R \} \{ \lambda \} = [\varphi_R]' \{ P \} \quad (2-268)$$

The second term is zero because of Equation 2-227. Solving for $\{ \lambda \}$, we have

$$\{ \lambda \} = ([\varphi_R]' [A] \{ \varphi_R \})^{-1} [\varphi_R]' ([A] \{ \ddot{p} \} - \{ P \}) \quad (2-269)$$

If this is substituted into Equation 2-267, we obtain

$$[K] \{ p \} = \{ P \} - [A] \{ \ddot{p} \} - [A] \{ \varphi_R \} ([\varphi_R]' [A] \{ \varphi_R \})^{-1} [\varphi_R]' (\{ P \} - [A] \{ \ddot{p} \}) \quad (2-270)$$

Contrails

Using Equation 2-255, this can be written as

$$[K] \{p\} = [\Gamma] (\{P\} - [A] \{ \ddot{p} \}) \quad (2-271)$$

This set of linear equations can be solved for the p's in terms of the right-hand side by the procedure which led to Equation 2-256. The only difference is that the right-hand side is

$$[\Gamma] (\{P\} - [A] \{ \ddot{p} \}) \quad (2-272)$$

in this case; whereas in the static case, considered before, the right-hand side was simply $\{P\}$. Condition 2-258 in the present case, is

$$[\varphi_R]' [\Gamma] (\{P\} - [A] \{ \ddot{p} \}) = \{0\} \quad (2-273)$$

which is identically satisfied because

$$\begin{aligned} [\varphi_R]' [\Gamma] &= [\varphi_R]' (\Gamma_{11} - [A] [\varphi_R]' ([\varphi_R]' [A] [\varphi_R])^{-1} [\varphi_R]') \\ &= [\varphi_R]' - [\varphi_R]' \\ &= [0] \end{aligned} \quad (2-274)$$

We may therefore write Equation 2-271 as

$$\{p\} = [\varphi_R] \{q_R\} + [\Gamma]' [E] [\Gamma] (\{P\} - [A] \{ \ddot{p} \}) \quad (2-275)$$

Consistent with our previous assumptions, however, we have $\{q_R\} = \{0\}$ (Equation 2-259), so that

$$\boxed{\{p\} = [\Gamma]' [E] [\Gamma] (\{P\} - [A] \{ \ddot{p} \})} \quad (2-276)$$

The coefficients, $[\Gamma]' [E] [\Gamma]$, come as close as anything to a generalized notion of influence coefficients. They appear to be the discrete analogy to the "generalized Green's function" introduced by Courant and discussed by Bisplinghoff in relation to aircraft structural analyses¹. In this report we

¹See R. Courant and D. Hilbert Methods of Mathematical Physics, Interscience, 1953, Vol. I, p. 354, and Bisplinghoff, Ashley, and Halfman Aeroelasticity, Addison-Wesley, 1955, p.24 .

shall refer to the coefficients in Equation 2-276 as the "free-body" influence coefficients¹. It is a curious consequence of the derivation given previously that the free-body influence coefficients are unique and independent of the arbitrary constraints assumed for the calculation of $[E]$. In some instances, a constrained influence coefficient matrix is calculated directly without using Equation 2-246. Such is the case when the "complementary strain energy" method is used (see Section 5.1.1.2 of this report).

Equation 2-276 is important for its application to some aeroelastic loads problems for unrestrained systems where the constraint, $\{q_R\} = \{0\}$, is not a serious one. We are presently interested, however, in its application to the problem of free vibrations.

For free vibrations we have $\{P\} = \{0\}$; and, as before, we assume a "product" solution,

$$\{p(t)\} = \{\varphi\} q(t) \quad (2-277)$$

in Equation 2-276 and arrive at

$$-\frac{q}{\delta} \{\varphi\} = [\Gamma]'[E][\Gamma][A]\{\varphi\} \quad (2-278)$$

which separates into the two equations

$$[\Gamma]'[E][\Gamma][A]\{\varphi\} = \lambda \{\varphi\} \quad (2-279)$$

$$\ddot{q} + \frac{1}{\lambda} q = 0 \quad (2-280)$$

Equation 2-279 is in a form suitable for a numerical solution by iteration. The results are the solutions to Equation 2-202 corresponding to $\omega_i \neq 0$. The zero-frequency modes, or rigid-body modes, can usually be written down immediately; however, in some rare cases Equation 2-203 must be used to calculate them.

In conclusion, we note that the response to time dependent forces (Equation 2-196) must be modified slightly in the case where there are zero-frequency modes. It can be shown that the Green's function, in this case, is

$$[G(t)] = \sum_{i=1}^M \{\varphi_R\}'_i ([\varphi_R]'[A][\varphi_R])^{-1} \{\varphi_R\}'_i \lim_{\omega_i \rightarrow 0} \left(\frac{\sin \omega_i t}{\omega_i} \right) + \sum_{i=1}^{N-M} \{\varphi\}'_i \{\varphi\}'_i \frac{\sin \omega_i t}{\omega_i} \quad (2-281)$$

¹See also the very interesting paper by B. M. Fraeys de Veubike, Iteration in Semidefinite Eigenvalue Problems, Journal of the Aeronautical Sciences, October, 1955.

Contrails

If we introduce the definitions,

$$[\psi]_0 = \sum_{i=1}^M \{\varphi_R\}_i ([\varphi_R]' [A] [\varphi_R])^{-1} \{\varphi_R\}'_i \quad (2-282)$$

$$[\psi]_i = \{\varphi\}_i \{\dot{\varphi}\}'_i \quad (2-283)$$

this can be written as

$$[G(t)] = [\psi]_0 t + \sum_{i=1}^{N-M} [\psi]_i \frac{\sin \omega_i t}{\omega_i} \quad (2-284)$$

and the general solution is

$$\begin{aligned} \{p(t)\} = \int_0^t [G(t-\tau)] \{P(\tau)\} d\tau + [\psi]_0 [A] (\{p(0)\} + t \{\dot{p}(0)\}) \\ + \sum_{i=1}^{N-M} [\psi]_i [A] (\{p(0)\} \cos \omega_i t \\ + \{\dot{p}(0)\} \frac{\sin \omega_i t}{\omega_i}) \end{aligned} \quad (2-285)$$

2.2.3.5 Solutions to the Linearly Damped Vibration Equations

The previous sections have dealt with Equation 2-140 in the case where the damping is zero. We want to consider, in this section, the damped equations with external forces which are a function of time only,

$$[A]\ddot{p} + [B]\dot{p} + [K]p = \{P(t)\} \quad (2-286)$$

In an attempt to solve these equations, we might be led to believe that the normal coordinate transformation (Equation 2-183) would uncouple these equations in the same way it uncoupled the equations with no damping. If we substitute

$$\{p\} = [\varphi] \{q\} \quad (2-287)$$

Contrails

into Equation 2-286 and premultiply by $[\phi]'$, we obtain

$$\{\ddot{q}\} + [\phi]'[B][\phi]\{\dot{q}\} + \{\lambda\}\{q\} = [\phi]'\{P\} \quad (2-288)$$

or

$$\{\ddot{q}\} + [R]\{\dot{q}\} + \{\lambda\}\{q\} = [\phi]'\{P\} \quad (2-289)$$

where

$$[R] = [\phi]'\{B\}[\phi] \quad (2-290)$$

is the damping matrix corresponding to the normal coordinates. The i^{th} equation is

$$\frac{d^2 q_i}{dt^2} + \sum_{j=1}^N r_{ij} \frac{dq_j}{dt} + \omega_i^2 q_i = \{\phi\}'_i \{P\} \quad (2-291)$$

These equations are only uncoupled when the modal damping matrix, $[R]$, is diagonal. There are some mechanical systems where the damping matrix is approximately proportional to the stiffness matrix (see also Section 3.1.1),

$$[B] = \beta [K] \quad (2-292)$$

and in this case

$$[R] = [\phi]'\{B\}[\phi] = \beta [\phi]'\{K\}[\phi] = \beta \{\lambda\} \quad (2-293)$$

so that

$$r_{ij} = \begin{cases} \beta \omega_i^2 & i=j \\ 0 & i \neq j \end{cases} \quad (2-294)$$

and Equation 2-291 becomes

$$\frac{d^2 q_i}{dt^2} + \beta \omega_i^2 \frac{dq_i}{dt} + \omega_i^2 q_i = \{\phi\}'_i \{P\} \quad (2-295)$$

Contrails

If we express this in terms of the "modal critical damping factor," ζ_i , we have

$$\frac{d^2 q_i}{dt^2} + 2\zeta_i \omega_i \frac{dq_i}{dt} + \omega_i^2 q_i = \{\varphi\}'_i \{P\} \quad (2-296)$$

with

$$\zeta_i = \frac{\beta}{2} \omega_i \quad (2-297)$$

For this type of damping the critical damping factor is higher in the higher frequency modes.

Lord Rayleigh has given a general proof that the solutions to Equation 2-291 are very little affected by assuming that

$$\pi_{ij} = 0 \quad (2-298)$$

$i \neq j$

when the damping is small¹. We then have the fairly general result that

$$\frac{d^2 q_i}{dt^2} + 2\zeta_i \omega_i \frac{dq_i}{dt} + \omega_i^2 q_i = \{\varphi\}'_i \{P\} \quad (2-299)$$

with

$$\zeta_i = \frac{\{\varphi\}'_i [B] \{\varphi\}_i}{2\omega_i} \quad (2-300)$$

For structures that are common in the aerospace industry, the damping factor defined in Equation 2-300 can be a very complicated function of the discrete undamped frequencies, ω_i . (Note, ω_i is a description, to some extent, of the stiffness distribution of the structure; ω_i^2 is sometimes called the generalized stiffness.) Figure 7 shows the type of empirical relations that are obtained from resonant frequency and decay measurements on a wide variety of structures. The last graph is indicative of systems characterized by Equation 2-292.

¹See Rayleigh, Theory of Sound Dover, 1945, Vol. I, Sec. 102, p. 136 and 137. Recently, Dr. T. K. Caughey has given a much more direct proof of this important result by using modern perturbation methods. See equation (44) in Effect of Damping on the Natural Frequencies of Linear Dynamic Systems by T. K. Caughey and M. E. J. O'Kelly; Journal of the Acoustical Society of America, Vol. 33, No. 11, pp. 1458-1461, November 1961.

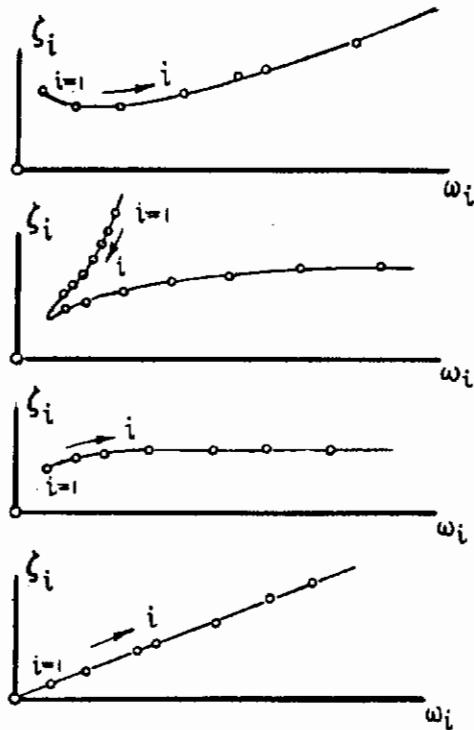

FIGURE 7 DAMPING CHARACTERISTICS FROM MEASUREMENTS OF $\zeta_i \omega_i$ AND $\sqrt{1-\zeta_i^2} \omega_i$

The solution to Equation 2-299 is fairly straightforward and we give only the final result so that we may direct our attention to the case where the [R]-matrix is not diagonal and the damping is not small. The Green's function for the system described by Equation 2-299 turns out to be

$$[G(t)] = \sum_{i=1}^N \{\varphi\}_i \{\varphi\}'_i e^{-\zeta_i \omega_i t} \frac{\sin \sqrt{1-\zeta_i^2} \omega_i t}{\sqrt{1-\zeta_i^2} \omega_i} \quad (2-301)$$

In the general case we must use a method devised by K. A. Foss¹ to find the solution for time dependent forces. A discussion of the general case follows.

¹K. A. Foss, Coordinates Which Uncouple the Equations of Motion of Damped Linear Dynamic Systems, Journal of Applied Mechanics, Sept., 1958.

Contrails

If we operate on Equation 2-286 with the Laplace transform, we obtain

$$(s^2[A] + s[B] + [K])\{\bar{p}(s)\} = \{\bar{P}(s)\} + s[A]\dot{p}(0) + [A]\dot{p}(0) + [B]p(0) \quad (2-302)$$

The formal solution to these equations is given by

$$\{\bar{p}(s)\} = (s^2[A] + s[B] + [K])^{-1} (\{\bar{P}(s)\} + s[A]\dot{p}(0) + [A]\dot{p}(0) + [B]p(0)) \quad (2-303)$$

We recall that, in the case of no damping, the admittance matrix (Equations 2-199 and 2-201) was given by

$$(s^2[A] + [K])^{-1} = \sum_{i=1}^N \frac{[\psi]_i}{s^2 + \omega_i^2} \quad (2-304)$$

Also, it can be shown that in the case leading to Equation 2-301, we have

$$(s^2[A] + s[B] + [K])^{-1} = \sum_{i=1}^N \frac{[\psi]_i}{s^2 + 2\gamma_i\omega_i s + \omega_i^2} \quad (2-305)$$

where

$$\gamma_i = \frac{\{\varphi\}'_i [B] \varphi'_i}{2\omega_i} \quad (2-306)$$

In both of these equations

$$[\psi]_i = \{\varphi\}'_i \{\varphi\}'_i \quad (2-307)$$

Our intentions are to show that in the general case of Equation 2-286, we have¹

$$(s^2[A] + s[B] + [K])^{-1} = \sum_{i=1}^N \frac{s[\psi]_i + [\psi_0]_i}{s^2 - 2\sigma_i s + \sigma_i^2 + \omega_i^2} \quad (2-308)$$

¹The principal difference between equations 2-305 and 2-308 reflects on the existence of the physical notion of a mode of vibration. This is discussed by T. K. Caughey in Classical Normal Modes in Damped Linear Dynamic Systems, Journal of Applied Mechanics, 27 E. (1960).

Contrails

where $[\psi_1]_i$ and $[\psi_0]_i$ are real matrices and $\sigma_i + i\omega_i$ is the i th complex root of the characteristic equation

$$\Delta(s) = |s^2[A] + s[B] + [K]| = 0 \quad (2-309)$$

We can reduce Equation 2-286 to a set of first order equations by introducing the generalized velocities as additional "coordinates." If we let

$$\{h\} = \{\dot{p}\} \quad (2-310)$$

then Equation 2-286 can be expressed as

$$[A]\dot{\{h\}} + [B]\{h\} + [K]\{p\} = \{P\} \quad (2-311)$$

with

$$\{h\} - \{\dot{p}\} = \{0\} \quad (2-312)$$

This set of first order equations can also be written as

$$[V]\frac{d\{p^*\}}{dt} + [W]\{p^*\} = \{P^*(t)\} \quad (2-313)$$

where

$$[V] = \begin{bmatrix} [A] & [0] \\ [0] & [1] \end{bmatrix} \quad (2-314)$$

$$[W] = \begin{bmatrix} [B] & [K] \\ -[1] & [0] \end{bmatrix} \quad (2-315)$$

$$\{p^*\} = \begin{bmatrix} \{h\} \\ \{p\} \end{bmatrix} \quad (2-316)$$

and

$$\{P^*\} = \begin{bmatrix} \{P\} \\ \{0\} \end{bmatrix} \quad (2-317)$$

Contrails

The Laplace transform of Equation 2-313 is

$$(s[V] + [W])\{\bar{p}^*(s)\} = \{\bar{p}^*(s)\} \quad (2-318)$$

We have assumed zero initial energy because we can generalize our final result by using Equation 2-303.

Equations 2-318 are easier to solve than the equations

$$(s^2[A] + s[B] + [K])\{\bar{p}(s)\} = \{\bar{p}(s)\} \quad (2-319)$$

although it is the latter set in which we are primarily interested.

To solve Equations 2-318 let us first consider the homogeneous equations

$$(s[V] + [W])\{\bar{p}^*\} = \{0\} \quad (2-320)$$

For non-trivial solutions we must have

$$\Delta(s) = |s[V] + [W]| = |s^2[A] + s[B] + [K]| = 0 \quad (2-321)$$

Corresponding to each root (which is, in general, complex), we have a solution to Equations 2-319 or 2-320. If $s = s_i$, $i = 1, 2, \dots, 2N$, are the solutions to $\Delta(s) = 0$, then

$$(s_i[V] + [W])\{\varphi^*\}_i = \{0\} \quad (2-322)$$

There are also solutions to the transposed equations

$$(s_i[V] + [W]')\{\eta^*\}_i = \{0\} \quad (2-323)$$

$$[V]' = [V] \quad \text{from Equation 2-314}$$

From these equations we can establish the following orthogonality relations

$$\{\eta^*\}_j' [V] \{\varphi^*\}_i = 0 \quad i \neq j \quad (2-324)$$

$$\{\eta^*\}_j' [W] \{\varphi^*\}_i = 0 \quad i \neq j \quad (2-325)$$

Contrails

$$s_i \{\eta^*\}'_i [V] \{\varphi^*\}_i + \{\eta^*\}'_i [W] \{\varphi^*\}_i = 0 \quad (2-326)$$

Let

$$[\varphi^*] = [\{\varphi^*\}_1, \{\varphi^*\}_2, \dots, \{\varphi^*\}_N, \{\bar{\varphi}^*\}_1, \{\bar{\varphi}^*\}_2, \dots, \{\bar{\varphi}^*\}_N] \quad (2-327)$$

$$[\eta^*] = [\{\eta^*\}_1, \{\eta^*\}_2, \dots, \{\eta^*\}_N, \{\eta^*\}_1, \{\eta^*\}_2, \dots, \{\eta^*\}_N] \quad (2-328)$$

In these matrices, the last N columns are the complex conjugate of the first N columns because the roots to $\Delta(s) = 0$ are generally complex and will occur in conjugate pairs. If we now consider the nonhomogeneous equations (Equations 2-318) and make the transformation,

$$\{\bar{p}^*\} = [\varphi^*] \{\bar{q}^*\} \quad (2-329)$$

in Equations 2-318, we obtain

$$(s[V] + [W])[\varphi^*] \{\bar{q}^*\} = \{\bar{p}^*\} \quad (2-330)$$

Premultiply by $[\eta^*]'$

$$[\eta^*]'(s[V] + [W])[\varphi^*] \{\bar{q}^*\} = [\eta^*]' \{\bar{p}^*\} \quad (2-331)$$

From the orthogonality relations (Equations 2-324 and 2-325), we have

$$[\eta^*]'(s[V] + [W])[\varphi^*] = \Gamma s \{\eta^*\}'_i [V] \{\varphi^*\}_i + \{\eta^*\}'_i [W] \{\varphi^*\}_i \quad (2-332)$$

Using Equation 2-326, we have

$$[\eta^*]'(s[V] + [W])[\varphi^*] = \Gamma s - s_i \quad (2-333)$$

where we have assumed the solutions to be normalized so that

$$\{\eta^*\}'_i [V] \{\varphi^*\}_i = 1 \quad (2-334)$$

Contrails

Using Equation 2-333 in Equation 2-331, we can solve for $\{\bar{q}^*\}$

$$\{\bar{q}^*\} = \Gamma \frac{1}{s-s_i} [\eta^*]' \{\bar{p}^*\} \quad (2-335)$$

Substituting this into Equation 2-329, we have

$$\{\bar{p}^*\} = [\varphi^*] \Gamma \frac{1}{s-s_i} [\eta^*]' \{\bar{p}^*\} \quad (2-336)$$

We can relate the modes of Equation 2-322 to the modes which satisfy

$$(s_i^2 [A] + s_i [B] + [K]) \{\varphi\}_i = \{0\} \quad (2-337)$$

By comparing Equation 2-337 with Equations 2-322 and 2-323, it can be shown that

$$\{\varphi^*\}_i = \begin{bmatrix} s_i \{\varphi\}_i \\ \{\varphi\}_i \end{bmatrix} \quad (2-338)$$

and

$$\{\eta^*\}_i = \begin{bmatrix} \{\varphi\}_i \\ \frac{1}{s_i} [K] \{\varphi\}_i \end{bmatrix} \quad (2-339)$$

$$s_i \neq 0$$

$$\{\eta^*\}_i = \begin{bmatrix} \{\varphi\}_i \\ [B] \{\varphi\}_i \end{bmatrix} \quad (2-340)$$

$$\text{for } s_i = 0$$

Substituting these in Equation 2-336 and using Equation 2-316, we have

$$\{\bar{h}\} = [\varphi] \Gamma s_i \Gamma \frac{1}{s-s_i} [\varphi]' \{\bar{p}\} \quad (2-341)$$

$$s_i \neq 0$$

Contrails

$$\{\bar{p}\} = [\varphi]^{-1} \frac{1}{s-s_i} [\varphi]' \{\bar{p}\} \quad (2-342)$$

The following identity is easily verified

$$[\varphi]^{-1} \frac{1}{s-s_i} [\varphi]' = \sum_{i=1}^{2N} \frac{1}{s-s_i} \{\varphi\}_i \{\varphi\}'_i \quad (2-343)$$

We can then express Equation 2-342 as

$$\begin{aligned} \{\bar{p}\} &= \sum_{i=1}^N \left(\frac{\{\varphi\}_i \{\varphi\}'_i}{s-s_i} + \frac{\{\bar{\varphi}\}_i \{\bar{\varphi}\}'_i}{s-\bar{s}_i} \right) \{\bar{p}\} \quad (2-344) \\ &= \sum_{i=1}^N \frac{(s-\bar{s}_i) \{\varphi\}_i \{\varphi\}'_i + (s-s_i) \{\bar{\varphi}\}_i \{\bar{\varphi}\}'_i}{(s-s_i)(s-\bar{s}_i)} \{\bar{p}\} \end{aligned}$$

If we let

$$s_i = \sigma_i + i\omega_i \quad (2-345)$$

and

$$[\psi_1]_i = 2 \operatorname{Re} (\{\varphi\}_i \{\varphi\}'_i) \quad (2-346)$$

$$[\psi_0]_i = -2 \operatorname{Re} (\bar{s}_i \{\varphi\}_i \{\varphi\}'_i) \quad (2-347)$$

then

$$\{\bar{p}\} = \sum_{i=1}^N \frac{s[\psi_1]_i + [\psi_0]_i}{s^2 - 2\sigma_i s + \sigma_i^2 + \omega_i^2} \{\bar{p}\} \quad (2-348)$$

Contrails

Comparing this with Equation 2-303, we must conclude that

$$\boxed{(s^2[A] + s[B] + [K])^{-1} = \sum_{i=1}^N \frac{s[\psi_1]_i + [\psi_0]_i}{s^2 - 2\sigma_i s + \sigma_i^2 + \omega_i^2}} \quad (2-349)$$

The above relation is for restrained systems only and it has been assumed that there are no zero roots. The case of common interest, however, is the case where the zero-frequency modes discussed in Paragraph 2.2.3.4 satisfy the relation

$$[B]\{\varphi_R\}_i = \{0\} \quad (2-350)$$

$$i = 1, 2, \dots, M$$

which is characteristic of internal damping in that no dissipation results from a mode in which there is no elastic deformation. The theoretical development is fairly complex in this case, but the result is what would be expected

$$(s^2[A] + s[B] + [K])^{-1} = \frac{1}{s^2}[\psi]_0 + \sum_{i=1}^{N-M} \frac{s[\psi_1]_i + [\psi_0]_i}{s^2 - 2\sigma_i s + \sigma_i^2 + \omega_i^2} \quad (2-351)$$

where $[\psi]_0$ is defined by Equation 2-282.

Numerical methods to solve either Equation 2-322 or Equation 2-337¹ are discussed in Appendix III.

In conclusion, we note that the Green's function corresponding to Equation 2-349 is

$$[G(t)] = \sum_{i=1}^N \frac{e^{\sigma_i t}}{\omega_i} (\sigma_i \sin \omega_i t + \omega_i \cos \omega_i t) [\psi_1]_i + \frac{e^{\sigma_i t}}{\omega_i} (\sin \omega_i t) [\psi_0]_i \quad (2-352)$$

and the general solution is the inverse transform of Equation 2-348

$$\{p(t)\} = \int_0^t [G(t-\tau)]\{P(\tau)\} d\tau \quad (2-353)$$

¹If unnormalized solutions to Equation 2-337 are obtained, then the following formulas must be used instead of Equations 2-346 and 2-347.

$$[\psi_1]_i = -2 \operatorname{Re} \left(\frac{\{\varphi\}_i \{\varphi'\}_i}{\{\varphi\}'_i [B] \{\varphi\}_i} \right) \quad [\psi_0]_i = 2 \operatorname{Re} \left(s_i \frac{\{\varphi\}_i \{\varphi'\}_i}{\{\varphi\}'_i [B] \{\varphi\}_i} \right)$$

Contrails

or

$$\{p(t)\} = \int_0^t \left(\frac{e^{\sigma_i(t-\tau)}}{\omega_i} (\sigma_i \sin \omega_i(t-\tau) + \omega_i \cos \omega_i(t-\tau)) [\psi_1]_i + \frac{e^{\sigma_i(t-\tau)}}{\omega_i} \sin \omega_i(t-\tau) [\psi_0]_i \right) \{P(\tau)\} d\tau \quad (2-354)$$

2.3 THE APPLICATIONS OF AN INTERPOLATION PROCEDURE FOR OBTAINING A FINITE DEGREE-OF-FREEDOM APPROXIMATION FOR CONTINUOUS ELASTIC STRUCTURES

In Sections 2.1 and 2.2 very little was said about the procedure for replacing a continuous system (with an infinite number of degrees-of-freedom) by one with only a finite number of degrees-of-freedom. In this section, attention will be given to discussion of the specific form of Equation 2-37 in the case of small motions.

2.3.1 The Kinematics of Small Motions

Let us suppose that the continuum of particles is in its equilibrium position at time, $t = 0$. Consistent with the assumptions of Section 2.2, the system of particles executes small motions about the equilibrium configuration. If we denote the position vector of the x-y-z particle at $t = 0$ by $\mathbb{L}(x,y,z)$, then

$$\mathbb{p}(x,y,z,t) = \mathbb{u}(x,y,z,t) - \mathbb{L}(x,y,z) \quad (2-355)$$

is the displacement vector of the x-y-z particle. Referred to the inertial base vectors introduced in Section 2.1, the position vector, \mathbb{L} , has components x, y, and z.

$$\mathbb{L}(x,y,z) = x \mathbb{I} + y \mathbb{J} + z \mathbb{K} \quad (3-256)$$

The instantaneous position vector of the x-y-z particle is then

$$\begin{aligned} \mathbb{u}(x,y,z,t) &= x \mathbb{I} + y \mathbb{J} + z \mathbb{K} + \mathbb{p}(x,y,z,t) \\ &= (x + p_x(x,y,z,t)) \mathbb{I} + (y + p_y(x,y,z,t)) \mathbb{J} \\ &\quad + (z + p_z(x,y,z,t)) \mathbb{K} \end{aligned} \quad (2-357)$$

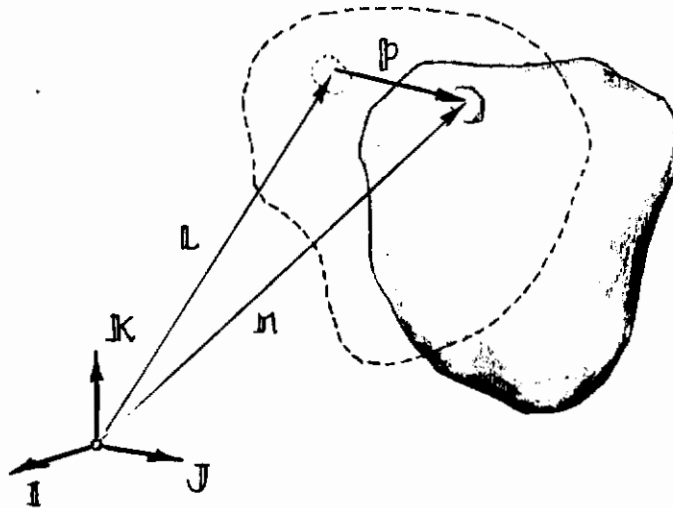

FIGURE 8 A PORTION OF THE SYSTEM DISPLACED FROM ITS EQUILIBRIUM POSITION

All of the assumptions of Section 2.2 are satisfied if we assume that

$$p(x, y, z, t) = \sum_{i=1}^N h_i(x, y, z) p_i(t) \quad (2-358)$$

We then have

$$\pi(p_1, p_2, \dots, p_N; x, y, z) = L(x, y, z) + \sum_{i=1}^N h_i(x, y, z) p_i \quad (2-359)$$

In particular,

$$\frac{\partial \pi}{\partial p_j} = h_j = \text{a constant, independent of the } p_i \quad (2-360)$$

as was assumed in Equation 2-122. Equation 2-358, expressed in components referred to I, J, and K, can be written as

$$p_x(x, y, z, t) = \sum_{i=1}^N h_x^{(i)}(x, y, z) p_i(t) \quad (2-361)$$

Contrails

$$p_y(x, y, z, t) = \sum_{i=1}^N h_y^{(i)}(x, y, z) p_i(t) \quad (2-362)$$

$$p_z(x, y, z, t) = \sum_{i=1}^N h_z^{(i)}(x, y, z) p_i(t) \quad (2-363)$$

The form of Equation 2-359 might be justified on the basis of small motions; that is, \mathcal{L} can be expanded in a Taylor's series,

$$\begin{aligned} \mathcal{L}(p_1, p_2, \dots, p_N; x, y, z) = & \mathcal{L}(0, 0, \dots, 0; x, y, z) + \sum_{i=1}^N \frac{\partial \mathcal{L}}{\partial p_i}(0, 0, \dots, 0; x, y, z) p_i \\ & + \frac{1}{2!} \sum_{i=1}^N \sum_{j=1}^N \frac{\partial^2 \mathcal{L}}{\partial p_i \partial p_j}(0, 0, \dots, 0; x, y, z) p_i p_j \end{aligned} \quad (2-364)$$

If the p_i are "small," then

$$\mathcal{L}(p_1, p_2, \dots, p_N; x, y, z) = \mathcal{L}(x, y, z) + \sum_{i=1}^N \frac{\partial \mathcal{L}}{\partial p_i}(0, 0, \dots, 0; x, y, z) p_i \quad (2-365)$$

which is the same as Equation 2-359. There is some indication, however, that the form of Equation 2-365 is justifiable even for "large" p_i .

The choice of the functions, $h_i(x, y, z)$, appears to be quite arbitrary; however, we must recall that the generalized coordinates can be independently varied without violating the constraints of the system. If, for example, the system is displaced so that $p_j = 1$ and $p_i = 0$ for $i \neq j$ then

$$p(x, y, z, t) = h_j(x, y, z) \quad (2-366)$$

From this we conclude that the h_i must satisfy all the physical constraints that are imposed on the displacements, $p(x, y, z, t)$. It also follows that no one of the h_i can be linear combination of the others; for if this were the case, the generalized coordinates would not be independent. These general conclusions were obtained by Rayleigh and were used as the basis of an approximate method devised by Ritz.

The interpolation procedure to be described below is concerned with an appropriate choice of the functions, $\{h_i\}$. This procedure has been considered only briefly in the literature although it has been used at Chance Vought (a parent organization of LTV Astronautics) for many years. The method had its origins in a paper by S. J. Loring published in 1941¹. By way of introduction, the method might be called a Rayleigh-Ritz approximation "in-the-small." In a very general sense, all finite degree-of-freedom approximations are Rayleigh-Ritz approximations in that the deformations of the structure are considered as a finite linear combination of known (assumed) deformation shapes. In the interpolation procedure the assumed functions are considered to be valid only over small regions of the system. In contrast to the conventional Rayleigh-Ritz technique, very little engineering judgement is required to pick approximate "assumed modes."

2.3.2 Interpolation in One-Dimension

To describe the values of a function in a region between points where the function is specified requires that some interpolation procedure be used. Any interpolation formula makes use of an assumed function for describing the ordinates between points where the ordinates are specified. To fix ideas we will consider first a very simple interpolation formula.

If a function, $p(x)$, is specified at a finite number of points in an interval, say $(0, L)$, then it is required to furnish values of the function at other points on the assumption that

$$p(x) = a_i x + b_i \quad (2-367)$$

$$\text{for } x_{i-1} \leq x \leq x_i$$

If p_i is the value of the function at $x = x_i$, then we also require that

$$p(x_i) = p_i \quad (2-368)$$

This is commonly called "trapezoidal interpolation" and it approximates the function $p(x)$ by a series of straight lines. Figure 9 shows the interval $(0, L)$ divided into N regions by $N + 1$ points, $0, x_1, x_2 \dots x_{N-1}, L$.

¹Loring, S. J., A General Approach to the Flutter Problem, Society of Automotive Engineering Journal, August 1941. This very fundamental paper, although specifically motivated by the wing flutter problem, developed a general approach to all vibration and aeroelastic problems. Loring developed his ideas while at Chance Vought in the period from 1936 to 1948. The general methodology presented in Section 2.0 of this report has principally evolved from Loring's original papers.

Contrails

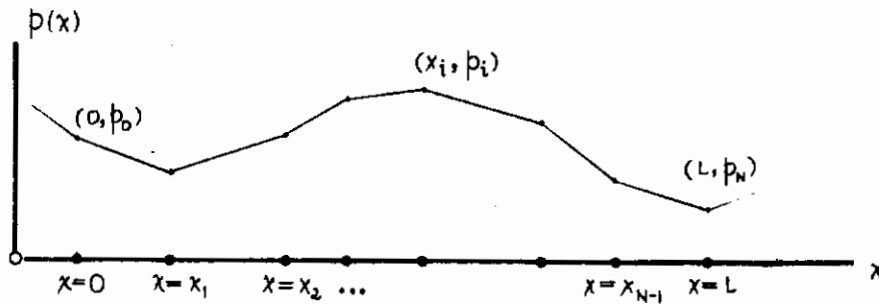

FIGURE 9 TRAPEZOIDAL INTERPOLATION

We may determine a_i in b_i in Equation 2-367 by using Equation 2-368.

$$p_{i-1} = p(x_{i-1}) = a_i x_{i-1} + b_i \quad (2-369)$$

$$p_i = p(x_i) = a_i x_i + b_i \quad (2-370)$$

Solving for a_i and b_i we obtain

$$\begin{bmatrix} a_i \\ b_i \end{bmatrix} = \begin{bmatrix} x_{i-1} & 1 \\ x_i & 1 \end{bmatrix}^{-1} \begin{bmatrix} p_{i-1} \\ p_i \end{bmatrix} \quad (2-371)$$

$$= \begin{bmatrix} \frac{-1}{x_i - x_{i-1}} & \frac{1}{x_i - x_{i-1}} \\ \frac{x_i}{x_i - x_{i-1}} & \frac{-x_{i-1}}{x_i - x_{i-1}} \end{bmatrix} \begin{bmatrix} p_{i-1} \\ p_i \end{bmatrix}$$

Contrails

If we substitute this into Equation 2-367, we have

$$p(x) = \begin{Bmatrix} x & 1 \end{Bmatrix} \begin{bmatrix} \frac{-1}{x_i - x_{i-1}} & \frac{1}{x_i - x_{i-1}} \\ \frac{x_i}{x_i - x_{i-1}} & \frac{-x_i}{x_i - x_{i-1}} \end{bmatrix} \begin{bmatrix} p_{i-1} \\ p_i \end{bmatrix} \quad (2-372)$$

valid for x on the interval
where $x_{i-1} \leq x \leq x_i$

Equation 2-372 relates the continuous function, $p(x)$, to the discrete values, p_i , on the interval $(0, L)$. If the matrix products are expanded, we obtain the more familiar form of the trapezoidal interpolation rule,

$$p(x) = p_{i-1} + \frac{x - x_{i-1}}{x_i - x_{i-1}} (p_i - p_{i-1}) \quad (2-373)$$

for $x_{i-1} \leq x \leq x_i$

In subsequent discussions we will find it very convenient to replace x by a "local" variable, ξ , which varies from 0 to 1 in the region where the interpolation formula is valid

$$\xi = \frac{x - x_{i-1}}{x_i - x_{i-1}} = \frac{x - x_{i-1}}{\Delta_i} \quad (2-374)$$

In terms of this variable, Equation 2-373 can be written as

$$p(x) = p(x_{i-1} + \xi \Delta_i) = p_{i-1} + \xi (p_i - p_{i-1}) \quad (2-375)$$

for $0 \leq \xi \leq 1$

and $x_{i-1} \leq x \leq x_i$

If this is expressed in the form of Equation 2-372, we have

$$p(x) = p(x_{i-1} + \xi \Delta_i) = \begin{Bmatrix} \xi & 1 - \xi \end{Bmatrix} \begin{bmatrix} \xi_i & -\xi_{i-1} \\ -1 & 1 \end{bmatrix} \begin{bmatrix} p_{i-1} \\ p_i \end{bmatrix} \quad (2-376)$$

or,

$$p(x) = \{1 \ \xi\} [S]_i \begin{bmatrix} p_{i-1} \\ p_i \end{bmatrix} \quad (2-377)$$

where

$$[S]_i = \begin{bmatrix} \xi_i & -\xi_{i-1} \\ -1 & 1 \end{bmatrix} = \begin{bmatrix} 1 & 0 \\ -1 & 1 \end{bmatrix} \quad (2-378)$$

for $i = 1, 2, \dots, N$

For applications to be considered in this report the trapezoidal formula is not adequate. A formula with more desirable properties has been developed by J. A. Griffin, Jr.¹ The formula, which he calls "diparabolic," has a simplicity, flexibility, and stability that is not achieved by many of the common interpolation methods.

The diparabolic formula is defined by averaging the "weighted" parabolic curves through each set of three adjacent points. More specifically, if $f_i(\xi)$ is the parabola through the points defined by the ordinates, p_{i-2} , p_{i-1} , and p_i ; and $f_{i+1}(\xi)$ is the parabola through the points defined by p_{i-1} , p_i , and p_{i+1} ; then the diparabolic formula approximates the function, $p(x)$, by

$$p(x) = (1-\xi)f_i(\xi) + \xi f_{i+1}(\xi) \quad (2-379)$$

for $x_{i-1} \leq x \leq x_i$

where, as before,

$$\xi = \frac{x - x_{i-1}}{x_i - x_{i-1}} \quad (2-380)$$

¹See Griffin, J. A., A Diparabolic Method of Four-Point Interpolation, Journal of the Aeronautical Sciences, Vol. 28, No. 2, Reader's Forum, February, 1961.

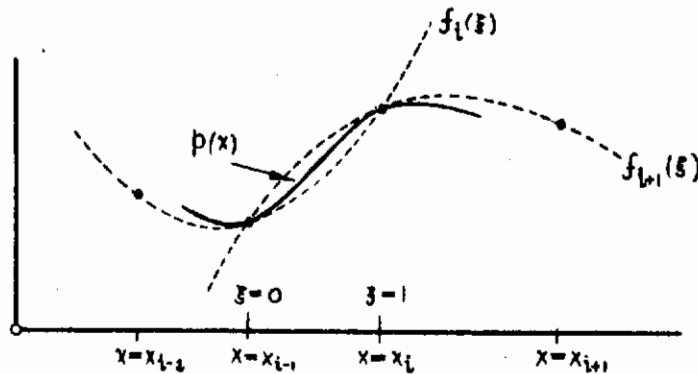

FIGURE 10 DIPARABOLIC INTERPOLATION

It is fairly straightforward to show that

$$f_i(s) = \{1 \ s \ s^2\} \begin{bmatrix} 1 & s_{i-2} & s_{i-2}^2 \\ 1 & s_{i-1} & s_{i-1}^2 \\ 1 & s_i & s_i^2 \end{bmatrix}^{-1} \begin{bmatrix} p_{i-2} \\ p_{i-1} \\ p_i \end{bmatrix} \quad (2-381)$$

Also, to simplify the discussion given here, we assume that the interval $(0, L)$ is divided into N equal intervals so that

$$x_i - x_{i-1} = h \quad \text{for all } i \quad (2-382)$$

We then have

$$\begin{aligned} s_{i-2} &= -1 \\ s_{i-1} &= 0 \\ s_i &= 1 \\ s_{i+1} &= 2 \end{aligned} \quad (2-383)$$

Contrails

and

$$f_i(s) = \{1 \ s \ s^2\} \begin{bmatrix} 0 & 1 & 0 \\ -\frac{1}{2} & 0 & \frac{1}{2} \\ \frac{1}{2} & -1 & \frac{1}{2} \end{bmatrix} \begin{bmatrix} p_{i-2} \\ p_{i-1} \\ p_i \end{bmatrix} \quad (2-384)$$

$$f_{i+1}(s) = \{1 \ s \ s^2\} \begin{bmatrix} 1 & 0 & 0 \\ -\frac{3}{2} & 2 & -\frac{1}{2} \\ \frac{1}{2} & -1 & \frac{1}{2} \end{bmatrix} \begin{bmatrix} p_{i-2} \\ p_{i-1} \\ p_i \end{bmatrix} \quad (2-385)$$

If we multiply Equation 2-384 by $(1 - \xi)$, then we may rearrange the terms in the form

$$(1-\xi)f_i(s) = \{1 \ s \ s^2 \ \xi s^3\} \begin{bmatrix} 0 & 1 & 0 \\ -\frac{1}{2} & -1 & \frac{1}{2} \\ 1 & -1 & 0 \\ -\frac{1}{2} & 1 & -\frac{1}{2} \end{bmatrix} \begin{bmatrix} p_{i-2} \\ p_{i-1} \\ p_i \end{bmatrix} \quad (2-386)$$

and in a similar manner,

$$\xi f_i(s) = \{1 \ s \ s^2 \ \xi s^3\} \begin{bmatrix} 0 & 0 & 0 \\ 1 & 0 & 0 \\ -\frac{3}{2} & 2 & -\frac{1}{2} \\ \frac{1}{2} & -1 & \frac{1}{2} \end{bmatrix} \begin{bmatrix} p_{i-1} \\ p_i \\ p_{i+1} \end{bmatrix} \quad (2-387)$$

Contrails

Substitution of these results in Equation 2-379 gives the desired form of the diparabolic formula

$$p(x) = \{1 \ s \ s^2 \ s^3\} \begin{bmatrix} 0 & 1 & 0 & 0 \\ -\frac{1}{2} & 0 & \frac{1}{2} & 0 \\ 1 & -\frac{3}{2} & 2 & -\frac{1}{2} \\ -\frac{1}{2} & \frac{3}{2} & -\frac{3}{2} & \frac{1}{2} \end{bmatrix} \begin{bmatrix} p_{i-2} \\ p_{i-1} \\ p_i \\ p_{i+1} \end{bmatrix} \quad (2-388)$$

valid for $x_{i-1} \leq x \leq x_i$

$0 \leq s = \frac{x - x_{i-1}}{L} < 1$

The above formula may be written more concisely as

$$p(x) = \{1 \ s \ s^2 \ s^3\} [\zeta] \{p\}_i \quad \text{for } x_{i-1} \leq x \leq x_i \quad (2-389)$$

where

$$\{p\}_i = \begin{bmatrix} p_{i-2} \\ p_{i-1} \\ p_i \\ p_{i+1} \end{bmatrix} \quad (2-390)$$

When unequal intervals are used, the interpolation coefficients, $[\zeta]$, are not the same for every interval; however, the set of 4 x 4 matrices,

$$[\zeta]_i \quad i = 1, 2, \dots, N \quad (2-391)$$

can be calculated when the coordinates, x_i , are specified.

It can be shown that the diparabolic formula defines a continuous curve with a continuous derivative on the interval from $x = 0$ to $x = L$. This important property of "smoothness" follows from the fact that Equation 2-389 satisfies

$$\lim_{s \rightarrow 1} \frac{dp}{dx} (x_{i-1} + sL) = \lim_{s \rightarrow 0} \frac{dp}{dx} (x_i + sL) \quad (2-392)$$

Constraints

Special consideration must be given to the end points if it is undesirable to have the collocation points, $x = x_i$, fall outside of the interval $(0, L)$. These points may be eliminated by arbitrarily imposing the conditions

$$\frac{d^2p}{dx^2}(0) = \frac{d^2p}{dx^2}(L) = 0 \quad (2-393)$$

In most applications this constraint introduces very little error¹. Using the relations

$$\frac{d^2p}{dx^2}(0) = \frac{1}{l^2} \{0 \ 0 \ 2 \ 0\} [\xi] \begin{bmatrix} p_{-1} \\ p_0 \\ p_1 \\ p_2 \end{bmatrix} = 0 \quad (2-394)$$

$$\frac{d^2p}{dx^2}(L) = \frac{1}{l^2} \{0 \ 0 \ 2 \ 6\} [\xi] \begin{bmatrix} p_{N-2} \\ p_{N-1} \\ p_N \\ p_{N+1} \end{bmatrix} = 0 \quad (2-395)$$

we can derive the following results which are appropriate for the first and N^{th} intervals

$$p(x) = \{1 \ \xi \ \xi^2 \ \xi^3\} \begin{bmatrix} 1 & 0 & 0 \\ -\frac{5}{4} & \frac{3}{2} & -\frac{1}{4} \\ 0 & 0 & 0 \\ \frac{1}{4} & -\frac{1}{2} & \frac{1}{4} \end{bmatrix} \begin{bmatrix} p_0 \\ p_1 \\ p_2 \end{bmatrix} \quad (2-396)$$

for $0 \leq x \leq x_1$

$$p(x) = \{1 \ \xi \ \xi^2 \ \xi^3\} \begin{bmatrix} 0 & 1 & 0 \\ -\frac{1}{2} & 0 & \frac{1}{2} \\ \frac{3}{4} & -\frac{3}{2} & \frac{3}{4} \\ -\frac{1}{4} & \frac{1}{2} & -\frac{1}{4} \end{bmatrix} \begin{bmatrix} p_{N-2} \\ p_{N-1} \\ p_N \end{bmatrix} \quad (2-397)$$

for $x_{N-1} \leq x \leq L$

¹No attempt is being made here to satisfy the "natural" boundary conditions for any particular problem. It is a consequence of the use of the Principles of Analytical Mechanics that the natural boundary conditions do not have to be considered, but are automatically satisfied.

2.3.3 Application of the Interpolation Technique to Some Typical Structures Problems

The concept of relating a continuous function to discrete values, as described above, can be generalized and applied to structures of widely varying geometries. To illustrate the technique we will consider briefly three problems:

- (1) the vibration of a uniform beam,
- (2) the vibration of a uniform simply-supported plate, and
- (3) the vibration of a uniform thin ring.

The numerical solution to these problems is compared with the exact solutions for the continuous case which is governed by a partial differential equation.

2.3.3.1 The Vibration of a Uniform Beam

The specific internal (strain) energy for a particle of a beam is

$$u(x, y, z, t) = \frac{1}{2} E \epsilon_{xx}^2 \quad (2-398)$$

If $p_z(x, t)$ is the lateral displacement of the neutral axis of the beam, the strain is given by

$$\epsilon_{xx} = -z \frac{\partial^2 p_z}{\partial x^2} \quad (2-399)$$

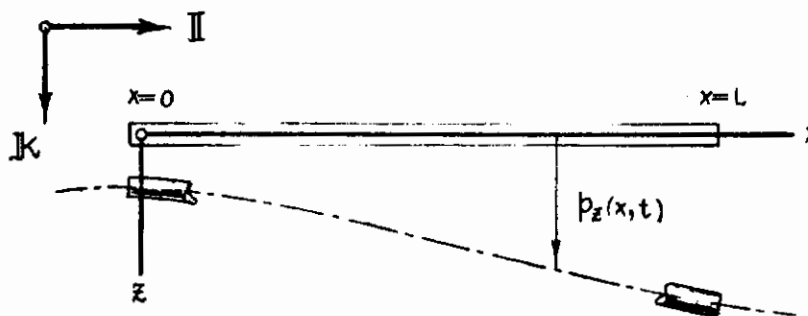

FIGURE 11 UNIFORM BEAM

Contrails

The total strain energy (Equation 2-56) is

$$\begin{aligned} U &= \int u \, dV & (2-400) \\ &= \iiint \frac{1}{2} E \left(z \frac{\partial^2 b_z}{\partial x^2} \right)^2 dx \, dy \, dz \\ &= \frac{1}{2} \int_0^L \iint E z^2 \, dy \, dz \left(\frac{\partial^2 b_z}{\partial x^2} \right)^2 dx \\ &= \frac{1}{2} \int_0^L EI(x) \left(\frac{\partial^2 b_z}{\partial x^2} \right)^2 dx. \end{aligned}$$

The total kinetic energy (Equation 2-42) is

$$\begin{aligned} T &= \frac{1}{2} \int \rho \left(\frac{\partial b_z}{\partial t} \right)^2 dV & (2-401) \\ &= \frac{1}{2} \int_0^L \iint \rho \, dy \, dz \left(\frac{\partial b_z}{\partial t} \right)^2 dx \\ &= \frac{1}{2} \int_0^L m(x) \left(\frac{\partial b_z}{\partial t} \right)^2 dx. \end{aligned}$$

In these expressions, $EI(x)$ is the beam "bending rigidity" and $m(x)$ is the mass per unit of length.

We want the elastic displacement of the continuous beam to be approximated by displacements at a finite number of discrete points. The procedure makes use of the diparabolic interpolation formula developed in Paragraph 2.3.2. For convenience, we will consider the points to be spaced at N equal intervals. The length of these intervals is

$$\ell = \frac{L}{N} = x_i - x_{i-1} \quad (2-402)$$

Contrails

If we denote the displacements at the points, $x = x_i$, by p_i , then

$$p_i(t) = p_x(x_i, t) \tag{2-403}$$

and from Equations 2-389, 2-396, and 2-397 we have

$$p_x(x, t) = \{1 \ \delta \ \delta^2 \ \delta^3\} [\mathcal{J}]_i \{p\}_i \tag{2-404}$$

$$\begin{aligned} \text{for } x_{i-1} \leq x \leq x_i \\ \delta = \frac{1}{L} (x - x_{i-1}) \end{aligned}$$

where

$$[\mathcal{J}]_i = \left\{ \begin{array}{l} \begin{bmatrix} 1 & 0 & 0 \\ -\frac{5}{4} & \frac{3}{2} & -\frac{1}{4} \\ 0 & 0 & 0 \\ \frac{1}{4} & -\frac{1}{2} & \frac{1}{4} \end{bmatrix} & \text{for } i = 1 \\ \begin{bmatrix} 0 & 1 & 0 & 0 \\ -\frac{1}{2} & 0 & \frac{1}{2} & 0 \\ 1 & -\frac{5}{2} & 2 & -\frac{1}{2} \\ -\frac{1}{2} & \frac{3}{2} & -\frac{3}{2} & \frac{1}{2} \end{bmatrix} & \text{for } i = 2, 3, \dots, N-1 \\ \begin{bmatrix} 0 & 1 & 0 \\ -\frac{1}{2} & 0 & \frac{1}{2} \\ \frac{3}{4} & -\frac{3}{2} & \frac{3}{4} \\ -\frac{1}{4} & \frac{1}{2} & -\frac{1}{4} \end{bmatrix} & \text{for } i = N \end{array} \right. \tag{2-405}$$

We can use Equation 2-404 to express the kinetic energy and strain energy in terms of the discrete displacements, p_i . Let us first write Equations 2-401 and 2-400 as

$$T = \frac{1}{2} \sum_{i=1}^N \int_{x_{i-1}}^{x_i} m \left(\frac{\partial p_x}{\partial t} \right)^2 dx \tag{2-406}$$

Contrails

$$U = \frac{1}{2} \sum_{i=1}^N \int_{x_{i-1}}^{x_i} EI \left(\frac{\partial^2 p_x}{\partial x^2} \right)^2 dx \quad (2-407)$$

and then make the following change of variable-of-integration

$$x = x_{i-1} + l\xi \quad (2-408)$$

for which

$$dx = l d\xi \quad (2-409)$$

and

$$\frac{\partial^2 p_x}{\partial x^2} = \frac{1}{l^2} \frac{\partial^2 p_x}{\partial \xi^2} \quad (2-410)$$

On substituting these into Equations 2-406 and 2-407, we find

$$T = \frac{1}{2} \sum_{i=1}^N \int_0^1 m \left(\frac{\partial p_x}{\partial t} \right)^2 l d\xi \quad (2-411)$$

$$U = \frac{1}{2} \sum_{i=1}^N \int_0^1 EI \left(\frac{\partial^2 p_x}{\partial x^2} \right)^2 \frac{1}{l^3} d\xi \quad (2-412)$$

From Equation 2-404 we have

$$\frac{\partial p_x}{\partial t} = \{1 \ \xi \ \xi^2 \ \xi^3\} [J]_i \{\dot{p}\}_i \quad (2-413)$$

$$\frac{\partial^2 p_x}{\partial \xi^2} = \{0 \ 0 \ 2 \ 6\xi\} [J]_i \{\dot{p}\}_i \quad \text{for } x_{i-1} \leq x \leq x_i \quad (2-414)$$

Contrails

By transposing Equations 2-413 and 2-414 and multiplying them by themselves, we obtain

$$\left(\frac{\partial p_x}{\partial t}\right)^2 = \{ \dot{p} \}_i' [J]_i' \begin{bmatrix} 1 \\ s \\ s^2 \\ s^3 \end{bmatrix} \{ 1 \ s \ s^2 \ s^3 \} [J]_i \{ p \}_i \quad (2-415)$$

$$\left(\frac{\partial p_x}{\partial s^2}\right)^2 = \{ p \}_i' [J]_i' \begin{bmatrix} 0 \\ 0 \\ 2 \\ 6s \end{bmatrix} \{ 0 \ 0 \ 2 \ 6s \} [J]_i \{ p \}_i \quad (2-416)$$

Substitution of Equations 2-415 and 2-416 into Equations 2-411 and 2-412 gives

$$T = \frac{1}{2} \sum_{i=1}^N \{ \dot{p} \}_i' [J]_i' \int_0^1 ml \begin{bmatrix} 1 & s & s^2 & s^3 \\ s & s^2 & s^3 & s^4 \\ s^2 & s^3 & s^4 & s^5 \\ s^3 & s^4 & s^5 & s^6 \end{bmatrix} ds [J]_i \{ \dot{p} \}_i \quad (2-417)$$

and

$$U = \frac{1}{2} \sum_{i=1}^N \{ p \}_i' [J]_i' \int_0^1 \frac{EI}{l^3} \begin{bmatrix} 0 & 0 & 0 & 0 \\ 0 & 0 & 0 & 0 \\ 0 & 0 & 4 & 12s \\ 0 & 0 & 12s & 36s^2 \end{bmatrix} ds [J]_i \{ p \}_i \quad (2-418)$$

If we define

$$[A]_i = [J]_i' \int_0^1 ml \begin{bmatrix} 1 & s & s^2 & s^3 \\ s & s^2 & s^3 & s^4 \\ s^2 & s^3 & s^4 & s^5 \\ s^3 & s^4 & s^5 & s^6 \end{bmatrix} ds [J]_i \quad (2-419)$$

Contrails

and

$$[K]_i = [J]_i \int_0^l \frac{EI}{l^3} \begin{bmatrix} 0 & 0 & 0 & 0 \\ 0 & 0 & 0 & 0 \\ 0 & 0 & 4 & 12l \\ 0 & 0 & 12l & 36l^2 \end{bmatrix} dz [J]_i \quad (2-420)$$

then a laborious numerical calculation gives

$$[A]_i = \begin{cases} \frac{ml}{6720} \begin{bmatrix} 1880 & 1224 & -164 \\ 1224 & 3264 & -288 \\ -164 & -288 & 32 \end{bmatrix} & \text{for } i = 1 \\ \frac{ml}{6720} \begin{bmatrix} 16 & -188 & -120 & 12 \\ -188 & 2720 & 1228 & -120 \\ -120 & 1228 & 2720 & -188 \\ 12 & -120 & -188 & 16 \end{bmatrix} & \text{for } i = 2, 3, \dots, N-1 \\ \frac{ml}{6720} \begin{bmatrix} 32 & -288 & -164 \\ -288 & 3264 & 1224 \\ -164 & 1224 & 1880 \end{bmatrix} & \text{for } i = N \end{cases} \quad (2-421)$$

and

$$[K]_i = \begin{cases} \frac{EI}{4l^3} \begin{bmatrix} 3 & -6 & 3 \\ -6 & 12 & -6 \\ 3 & -6 & 3 \end{bmatrix} & \text{for } i = 1 \\ \frac{EI}{4l^3} \begin{bmatrix} 4 & -10 & 8 & -2 \\ -10 & 28 & -26 & 8 \\ 8 & -26 & 28 & -10 \\ -2 & 8 & -10 & 4 \end{bmatrix} & \text{for } i = 2, 3, \dots, N-1 \\ \frac{EI}{4l^3} \begin{bmatrix} 3 & -6 & 3 \\ -6 & 12 & -6 \\ 3 & -6 & 3 \end{bmatrix} & \text{for } i = N \end{cases} \quad (2-422)$$

Contrails

For a nonuniform beam $[A]_i$ and $[K]_i$ must be calculated using a numerical integration (this is discussed in Paragraph 2.3.3.4). In either case, Equations 2-417 and 2-418 can be written as

$$\tau = \frac{1}{2} \sum_{i=1}^N \{p\}_i' [A]_i \{p\}_i \quad (2-423)$$

$$u = \frac{1}{2} \sum_{i=1}^N \{p\}_i' [K]_i \{p\}_i \quad (2-424)$$

If we define

$$\{p\} = \begin{bmatrix} p_0 \\ p_1 \\ \vdots \\ p_{N-1} \\ p_N \end{bmatrix} \quad (2-425)$$

then we can introduce transformation matrices that are defined by the relations

$$\{p\}_i = [\tau]_i \{p\} \quad (2-426)$$

Constraints

For the purpose of calculating an influence coefficient matrix, we assume the following constraints

$$p_z(L, t) = 0 \quad (2-438)$$

$$\frac{\partial p_z}{\partial x}(L, t) = 0 \quad (2-439)$$

which are just sufficient to prevent rigid-body motion. These constraints "cantilever" the beam at $x = L$. Using Equation 2-404, Equations 2-438 and 2-439 lead to

$$p_z(L, t) = \{1 \ 1 \ 1 \ 1\} \begin{bmatrix} 0 & 1 & 0 \\ -\frac{1}{2} & 0 & \frac{1}{2} \\ \frac{3}{4} & -\frac{3}{2} & \frac{3}{4} \\ -\frac{1}{4} & \frac{1}{2} & -\frac{1}{4} \end{bmatrix} \begin{bmatrix} p_{N-2} \\ p_{N-1} \\ p_N \end{bmatrix} = 0 \quad (2-440)$$

$$\frac{\partial p_z}{\partial x}(L, t) = \frac{1}{l} \{0 \ 1 \ 2 \ 3\} \begin{bmatrix} 0 & 1 & 0 \\ -\frac{1}{2} & 0 & \frac{1}{2} \\ \frac{3}{4} & -\frac{3}{2} & \frac{3}{4} \\ -\frac{1}{4} & \frac{1}{2} & -\frac{1}{4} \end{bmatrix} \begin{bmatrix} p_{N-2} \\ p_{N-1} \\ p_N \end{bmatrix} = 0 \quad (2-441)$$

or

$$\begin{bmatrix} 0 & 0 & 1 \\ \frac{1}{4} & -\frac{3}{2} & \frac{3}{4} \end{bmatrix} \begin{bmatrix} p_{N-2} \\ p_{N-1} \\ p_N \end{bmatrix} = \begin{bmatrix} 0 \\ 0 \end{bmatrix} \quad (2-442)$$

Constraints

which we may solve to find that

$$p_N = 0 \quad (2-443)$$

$$p_{N-1} = \frac{1}{6} p_{N-2} \quad (2-444)$$

We may also write these constraints in the form of the [S]-matrix discussed in Paragraph 2.2.3.4 (Equation 2-225).

$$\begin{bmatrix} p_0 \\ p_1 \\ p_2 \\ \vdots \\ p_{N-2} \\ p_{N-1} \\ p_N \end{bmatrix} = \begin{bmatrix} 1 & 0 & 0 & \dots & 0 \\ 0 & 1 & 0 & \dots & 0 \\ 0 & 0 & 1 & \dots & 0 \\ \vdots & \vdots & \vdots & \ddots & \vdots \\ 0 & 0 & 0 & \dots & 1 \\ 0 & 0 & 0 & \dots & \frac{1}{6} \\ 0 & 0 & 0 & \dots & 0 \end{bmatrix} \begin{bmatrix} p_0 \\ p_1 \\ p_2 \\ \vdots \\ p_{N-2} \end{bmatrix} \quad (2-445)$$

If we let the coefficient matrix in the above equation be [S], then

$$[E] = [S]([S]^{-1}[K][S])^{-1}[S]' \quad (2-446)$$

is an influence matrix for the beam cantilevered at $x = L$. The [Γ]-matrix defined in Equation 2-255, in this particular case, is

$$[\Gamma] = [1] - [A] \left\{ \begin{matrix} \vdots \\ \vdots \\ \vdots \end{matrix} \right\} \left\{ \begin{matrix} \vdots \\ \vdots \\ \vdots \end{matrix} \right\}' \frac{1}{mL} + \frac{12}{N^2} \left\{ \begin{matrix} i - \frac{1}{2} \\ i - \frac{1}{2} \\ i - \frac{1}{2} \end{matrix} \right\} \left\{ \begin{matrix} \vdots \\ \vdots \\ \vdots \end{matrix} \right\}' \frac{1}{mL} \quad (2-447)$$

Solution of the equation,

$$[\Gamma]'[E][\Gamma][A]\{\varphi\} = \lambda\{\varphi\} \quad (2-448)$$

by iteration gave the following values for the non-dimensional frequency parameter, $\omega_i^2 \frac{mL^4}{EI}$

TABLE 1 FREQUENCIES OF UNIFORM BEAM, COLLOCATION METHOD

	i = 1	i = 2	i = 3
$\omega_i^2 \frac{mL^4}{EI}$	517.66	4246.77	17,819.1

The exact solution of the partial differential equation,

$$EI \frac{\partial^4 p_z}{\partial x^4} = m \frac{\partial^2 p_z}{\partial t^2} \quad (2-449)$$

for the case of free-free boundary conditions gives¹

TABLE 2 FREQUENCIES OF UNIFORM BEAM, EXACT SOLUTION

	i = 1	i = 2	i = 3
$\omega_i^2 \frac{mL^4}{EI}$	500.42	3303.19	14,616.8

Also, for comparison, the first two vibration modes are given in Table 3

TABLE 3 MODES OF UNIFORM BEAM

FIRST MODE		SECOND MODE			
	Exact Solution		Exact Solution		
$\{\phi\}_1 =$	$\begin{bmatrix} 1.000 \\ 0.531 \\ 0.093 \\ -0.271 \\ -0.514 \\ -0.599 \\ -0.514 \\ -0.271 \\ 0.093 \\ 0.531 \\ 1.000 \end{bmatrix}$	$\begin{bmatrix} 1.0000 \\ 0.5372 \\ 0.0977 \\ -0.2720 \\ -0.5203 \\ -0.6078 \\ -0.5203 \\ -0.2720 \\ 0.0977 \\ 0.5372 \\ 1.0000 \end{bmatrix}$	$\{\phi\}_2 =$	$\begin{bmatrix} 1.000 \\ 0.212 \\ -0.393 \\ -0.639 \\ -0.462 \\ 0.000 \\ 0.462 \\ 0.639 \\ 0.393 \\ -0.212 \\ -1.000 \end{bmatrix}$	$\begin{bmatrix} 1.0000 \\ 0.2274 \\ -0.3973 \\ -0.6620 \\ -0.4830 \\ 0.0000 \\ 0.4830 \\ 0.6620 \\ 0.3973 \\ -0.2274 \\ -1.0000 \end{bmatrix}$

¹These values are taken from Scanlan and Rosenbaum, An Introduction to the Study of Aircraft Vibration and Flutter, Macmillan, 1951, p. 146.

The exact modes were obtained from Tables of Characteristic Functions Representing Normal Modes of Vibration of a Beam, University of Texas Publication No. 4913, July 1, 1941, by Dana Young and Robert P. Felgar, Jr.

Contrails

The comparison, for this case of 10 intervals, shows the diparabolic method to give favorable results. The agreement can be expected to be much better when more intervals are used. These results should also be compared with the "complementary strain energy" method discussed in Section 5.1.1.2. (A numerical comparison is considered in Section 5.2.1 of this report.)

In conclusion, we note that the interpolation scheme can be viewed as a Rayleigh-Ritz method. Equation 2-363, in the case of a beam, is

$$p_z(x,t) = \sum_{i=0}^{N+1} h_z^{(i)}(x) p_i(t) \quad (2-450)$$

Comparison of this with Equation 2-404 will show that the "assumed modes," $h_z^{(i)}(x)$, have the form indicated in Figure 12.

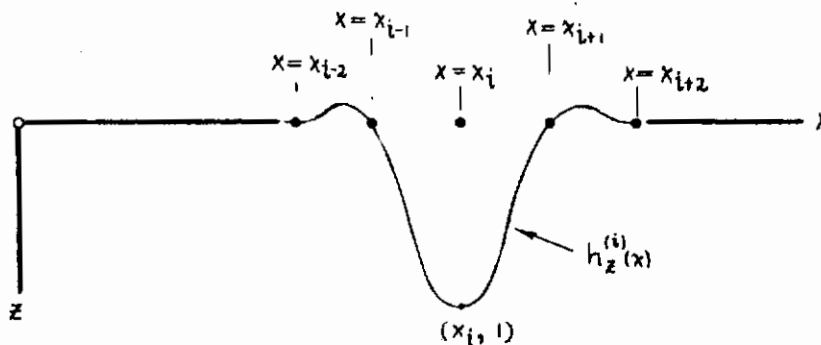

FIGURE 12 THE "ASSUMED MODES" CORRESPONDING TO THE DIPARABOLIC INTERPOLATION METHOD

The function in Figure 12 is defined by

$$h_z^{(i)}(x) = \begin{cases} 0 & \text{when } x < x_{i-2} \\ -0.5 \left(\frac{x-x_{i-2}}{l} \right) + 0.5 \left(\frac{x-x_{i-2}}{l} \right)^2 & x_{i-2} \leq x < x_{i-1} \\ 0.5 + 2 \left(\frac{x-x_{i-1}}{l} \right)^2 - 1.5 \left(\frac{x-x_{i-1}}{l} \right)^3 & x_{i-1} \leq x \leq x_i \\ 1.0 - 2.5 \left(\frac{x-x_i}{l} \right)^2 + 1.5 \left(\frac{x-x_i}{l} \right)^3 & x_i \leq x \leq x_{i+1} \\ -0.5 + \left(\frac{x-x_{i+1}}{l} \right)^2 - 0.5 \left(\frac{x-x_{i+1}}{l} \right)^3 & x_{i+1} \leq x \leq x_{i+2} \\ 0 & x > x_{i+2} \end{cases} \quad (2-451)$$

For comparison, Figure 13 shows the "assumed modes" corresponding to the trapezoidal interpolation assumption.

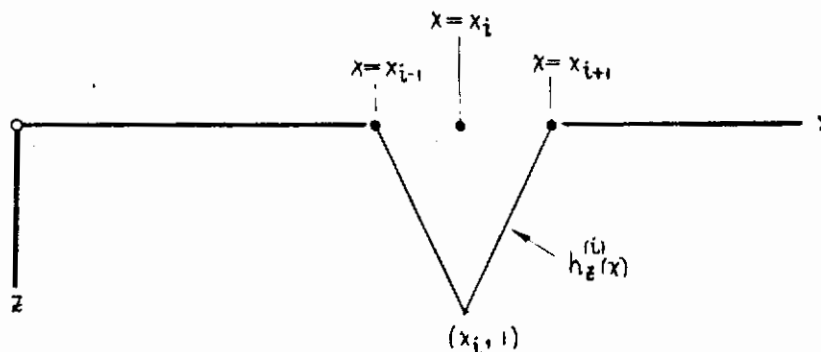

FIGURE 13 THE "ASSUMED MODES" CORRESPONDING TO THE TRAPEZOIDAL INTERPOLATION METHOD

2.3.3.2 The Vibration of a Uniform Simply-Supported Plate

The specific internal energy for a particle of a plate is

$$u(x,y,z,t) = \frac{1}{2} \frac{E}{1-\nu^2} (\epsilon_{xx}^2 + \epsilon_{yy}^2 + 2\nu\epsilon_{xx}\epsilon_{yy}) + \frac{1}{2} \frac{E}{2(1+\nu)} \epsilon_{xy}^2 \quad (2-452)$$

If $p_z(x,y,t)$ is the lateral displacement of the neutral surface of the plate, the components of strain are given by

$$\epsilon_{xx} = -z \frac{\partial^2 p_z}{\partial x^2} \quad (2-453)$$

$$\epsilon_{yy} = -z \frac{\partial^2 p_z}{\partial y^2} \quad (2-454)$$

$$\epsilon_{xy} = -2z \frac{\partial^2 p_z}{\partial x \partial y} \quad (2-455)$$

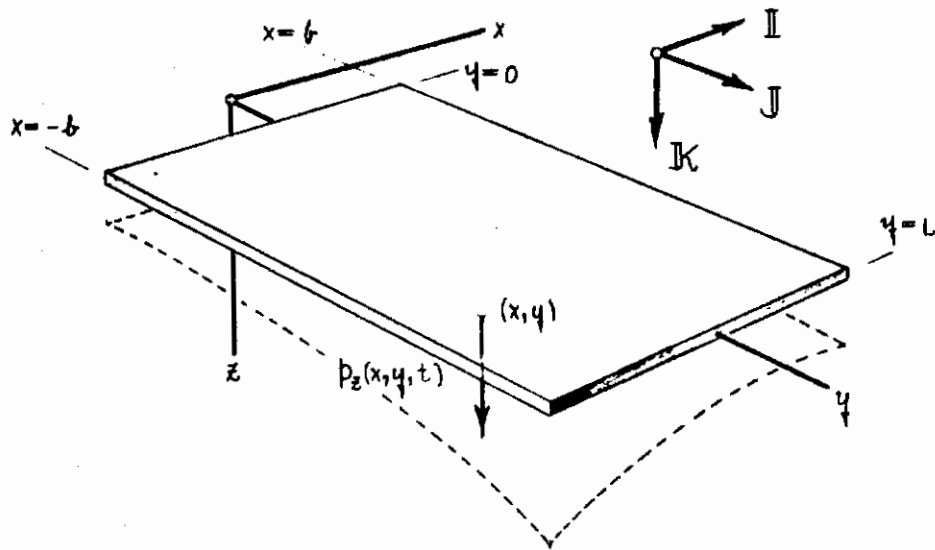

FIGURE 14 UNIFORM PLATE

The total strain energy is

$$\begin{aligned}
 U &= \int u \, dV && (2-456) \\
 &= \iiint \frac{E z^2}{2(1-\nu^2)} \left(\left(\frac{\partial^2 p_z}{\partial x^2} \right)^2 + \left(\frac{\partial^2 p_z}{\partial y^2} \right)^2 + 2\nu \left(\frac{\partial^2 p_z}{\partial x^2} \right) \left(\frac{\partial^2 p_z}{\partial y^2} \right) + 2(1-\nu) \left(\frac{\partial^2 p_z}{\partial x \partial y} \right)^2 \right) dx dy dz \\
 &= \frac{1}{2} \int_0^L \int_{-b}^b EI(x, y) \left(\left(\frac{\partial^2 p_z}{\partial x^2} \right)^2 + \left(\frac{\partial^2 p_z}{\partial y^2} \right)^2 + 2\nu \left(\frac{\partial^2 p_z}{\partial x^2} \right) \left(\frac{\partial^2 p_z}{\partial y^2} \right) + 2(1-\nu) \left(\frac{\partial^2 p_z}{\partial x \partial y} \right)^2 \right) dx dy
 \end{aligned}$$

where

$$EI(x,y) = \int \frac{Ez^2}{1-\nu^2} dz \quad (2-457)$$

is the plate "bending rigidity." For a plate of uniform thickness, τ , we have

$$EI = \frac{E\tau^3}{12(1-\nu^2)} \quad (2-458)$$

The total kinetic energy of the plate is

$$\begin{aligned} T &= \frac{1}{2} \int \rho \left(\frac{\partial b_z}{\partial t} \right)^2 dV & (2-459) \\ &= \frac{1}{2} \int_0^L \int_{-b}^b \int \rho dz \left(\frac{\partial b_z}{\partial t} \right)^2 dx dy \\ &= \frac{1}{2} \int_0^L \int_{-b}^b m(x,y) \left(\frac{\partial b_z}{\partial t} \right)^2 dx dy \end{aligned}$$

where $m(x,y)$ is the mass per unit of area which, for a uniform plate, is

$$m(x,y) = m = \rho\tau \quad (2-460)$$

In analogy to the procedures in Paragraph 2.3.3.1, we will divide the plate into a number of equal regions as shown in Figure 15.

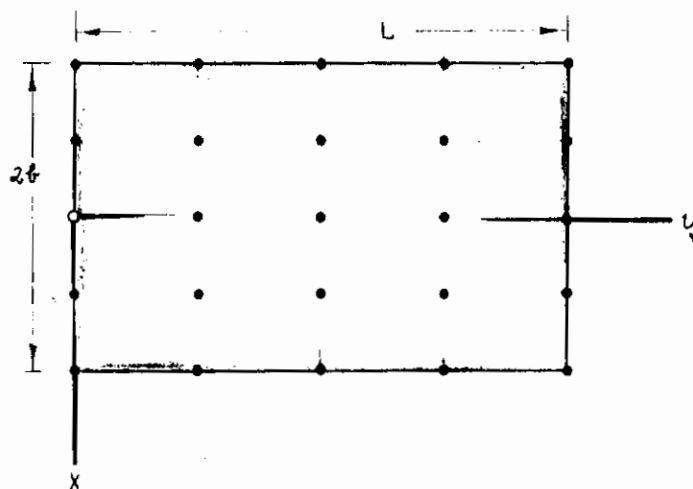

FIGURE 15 COLLOCATION POINTS ON THE PLATE

Contrails

If we let N be the number of equal intervals in the y -direction and M be the number of intervals in the x -direction, the length of these intervals will be

$$w = \frac{L}{N} \tag{2-461}$$

$$l = \frac{2b}{M} \tag{2-462}$$

We then introduce the following "local" coordinates

$$\xi = \frac{x - x_i}{l} \tag{2-463}$$

$$\eta = \frac{y - y_i}{w} \tag{2-464}$$

where (x_i, y_i) are the coordinates of the upper left corner (in Figure 16) of the i^{th} region.

For the i^{th} region it is possible to construct an interpolation formula which is a two-dimensional generalization of Equation 2-404.

$$p_2(x, y, t) = \{f(\xi, \eta)\}' [\xi]_i \{p\}_i \tag{2-465}$$

(x, y) in the i^{th} region

where

$$\{f(\xi, \eta)\} = \begin{bmatrix} 1 \\ \xi \\ \xi^2 \\ \eta \\ \eta\xi \\ \eta\xi^2 \\ \eta^2 \\ \eta^2\xi \\ \eta^2\xi^2 \\ \eta^3 \\ \eta^3\xi \\ \eta^3\xi^2 \\ \xi^3 \\ \eta\xi^3 \\ \eta^2\xi^3 \\ \eta^3\xi^3 \end{bmatrix} \tag{2-466}$$

Contrails

The displacement at any point in the region is given in terms of the discrete displacements at 16 neighboring points as shown in Figure 16. The resulting matrix of interpolation coefficients is 16 by 16.

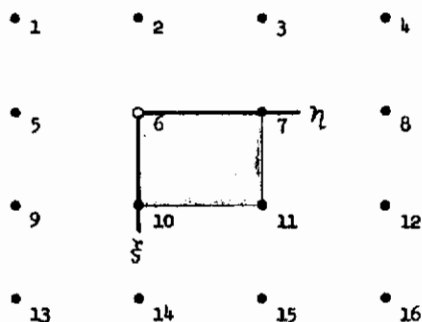

FIGURE 16 NUMBERING OF POINTS IN THE i^{th} REGION

The interpolation coefficients for edge regions are derived by eliminating the virtual points with the arbitrary conditions,

$$\frac{\partial^2 p_z}{\partial \xi^2} + 0.3 \frac{\partial^2 p_z}{\partial \eta^2} = 0 \quad (2-467)$$

and

$$\frac{\partial^2 p_z}{\partial \xi \partial \eta} = 0 \quad (2-468)$$

evaluated at the two discrete points in the region which fall on the edge¹. This leads to

$$\begin{bmatrix} 0 & 0 & 2 & 0 & 0 & 0 & 0.6 & 0 & 0 & 0 & 0 & 0 & 0 & 0 & 0 \\ 0 & 0 & 0 & 0 & 1 & 0 & 0 & 0 & 0 & 0 & 0 & 0 & 0 & 0 & 0 \\ 0 & 0 & 0 & 0 & 0 & 2 & 0.6 & 0 & 2 & 1.8 & 0 & 2 & 0 & 0 & 0 \\ 0 & 0 & 0 & 0 & 1 & 0 & 0 & 2 & 0 & 0 & 3 & 0 & 0 & 0 & 0 \end{bmatrix} [\xi] \{p\}_i = \{0\} \quad (2-469)$$

for edges on the top ($x = -b$, in this case). In this relation, $[\xi]$ is the two-dimensional equal interval interpolation matrix for interior regions which is tabulated in Appendix IV. Equation 2-469 can be used to eliminate points 1, 2, 3 and 4, and arrive at an interpolation matrix which is 16 by 12. A similar procedure can be used to obtain interpolation coefficients for the bottom, left-hand, and right-hand edges. The edge interpolation coefficients are also tabulated in Appendix IV.

¹The comments made previously about Equation 2-393 apply here also. The motive for choosing Equations 2-467 and 2-468 stems from the Kirchoff conditions for a plate (see Section 22 on page 83 of Timoshenko and Woinowsky-Krieger, Theory of Plates and Shells, McGraw-Hill, 1959).

Contrails

From Equation 2-465 we have

$$\frac{\partial p_z}{\partial t}(x, y, t) = \{f(s, \eta)\}' [s]_i \dot{p}_i \quad (2-470)$$

and from this,

$$\left(\frac{\partial p_z}{\partial t}\right)^2 = \{\dot{p}_i\}' [s]_i' \{f(s, \eta)\} \{f(s, \eta)\}' [s]_i \dot{p}_i \quad (2-471)$$

Let us write Equation 2-459 as

$$T = \frac{1}{2} \sum_{i=1}^{N \cdot M} \iint m \left(\frac{\partial p_z}{\partial t}\right)^2 dx dy \quad (2-472)$$

and make the following change of variable-of-integration

$$x = l s + x_i \quad (2-473)$$

$$y = w \eta + y_i \quad (2-474)$$

for which

$$dx dy = w l ds d\eta \quad (2-475)$$

Equation 2-472 becomes

$$T = \frac{1}{2} \sum_{i=1}^{N \cdot M} \int_0^1 \int_0^1 m w l \left(\frac{\partial p_z}{\partial t}\right)^2 ds d\eta \quad (2-476)$$

Substituting Equation 2-471, we get

$$T = \frac{1}{2} \sum_{i=1}^{N \cdot M} \{\dot{p}_i\}' [A]_i \dot{p}_i \quad (2-477)$$

Contrails

where

$$[A]_i = [J]_i' \int_0^1 \int_0^1 m w l \{f(x, \eta)\} \{f(x, \eta)\}' d\xi d\eta [J]_i \quad (2-478)$$

The matrix,

$$[\Gamma_1] = \int_0^1 \int_0^1 \{f(x, \eta)\} \{f(x, \eta)\}' d\xi d\eta \quad (2-479)$$

is tabulated in Appendix IV of this report. We can also write the strain energy in a similar manner. From Equation 2-456, we write

$$U = \frac{1}{2} \sum_{i=1}^{N-M} \int_0^1 \int_0^1 EI w l \left(\left(\frac{\partial^2 p_E}{\partial x^2} \right)^2 + \left(\frac{\partial^2 p_E}{\partial y^2} \right)^2 + 2\gamma \left(\frac{\partial^2 p_E}{\partial x^2} \right) \left(\frac{\partial^2 p_E}{\partial y^2} \right) + 2(1-\gamma) \left(\frac{\partial^2 p_E}{\partial x \partial y} \right)^2 \right) d\xi d\eta \quad (2-480)$$

From Equation 2-465, we have

$$\frac{\partial^2 p_E}{\partial x^2} = \frac{1}{l^2} \left\{ \frac{\partial^2 f}{\partial \xi^2} \right\}' [J]_i \{p\}_i \quad (2-481)$$

$$\frac{\partial^2 p_E}{\partial y^2} = \frac{1}{w^2} \left\{ \frac{\partial^2 f}{\partial \eta^2} \right\}' [J]_i \{p\}_i \quad (2-482)$$

$$\frac{\partial^2 p_E}{\partial x \partial y} = \frac{1}{w l} \left\{ \frac{\partial^2 f}{\partial \xi \partial \eta} \right\}' [J]_i \{p\}_i \quad (2-483)$$

We then define

$$[K]_i = \frac{EI}{w l} [J]_i' \left(\left(\frac{w}{l} \right)^2 [\Gamma_2] + \left(\frac{l}{w} \right)^2 [\Gamma_3] + 2\gamma [\Gamma_4] + 2(1-\gamma) [\Gamma_5] \right) [J]_i \quad (2-484)$$

Contrails

where

$$[\Gamma_2] = \int_0^1 \int_0^1 \left\{ \frac{\partial^2 f}{\partial \xi^2} \right\} \left\{ \frac{\partial^2 f}{\partial \xi^2} \right\}' d\xi d\eta \quad (2-485)$$

$$[\Gamma_3] = \int_0^1 \int_0^1 \left\{ \frac{\partial^2 f}{\partial \eta^2} \right\} \left\{ \frac{\partial^2 f}{\partial \eta^2} \right\}' d\xi d\eta \quad (2-486)$$

$$[\Gamma_4] = \int_0^1 \int_0^1 \frac{1}{2} \left(\left\{ \frac{\partial^2 f}{\partial \xi^2} \right\} \left\{ \frac{\partial^2 f}{\partial \eta^2} \right\}' + \left\{ \frac{\partial^2 f}{\partial \eta^2} \right\} \left\{ \frac{\partial^2 f}{\partial \xi^2} \right\}' \right) d\xi d\eta \quad (2-487)$$

$$[\Gamma_5] = \int_0^1 \int_0^1 \left\{ \frac{\partial^2 f}{\partial \xi \partial \eta} \right\} \left\{ \frac{\partial^2 f}{\partial \xi \partial \eta} \right\}' d\xi d\eta \quad (2-488)$$

(These matrices are also tabulated in Appendix IV.)

Equation 2-480 can then be written as

$$U = \frac{1}{2} \sum_{i=1}^{N \cdot M} \{p\}_i \{K\}_i \{p\}_i \quad (2-489)$$

As in Paragraph 2.3.3.1, we introduce transformation matrices defined by

$$\{p\}_i = [T]_i \{p\} \quad (2-490)$$

For the case of $N = 4$ and $M = 4$, there are 25 points (see Figure 15). For the case of simple supports on all edges, it can be shown that the interpolation formula (Equation 2-465) dictates that $p_i = 0$ for all points on the edges. If the remaining points are numbered as shown in Figure 17, then

$$\{p\} = \begin{bmatrix} p_1 \\ p_2 \\ \vdots \\ p_9 \end{bmatrix} \quad (2-491)$$

and the transformation matrices in Equation 2-490 have zeros in the appropriate rows corresponding to the boundary points.

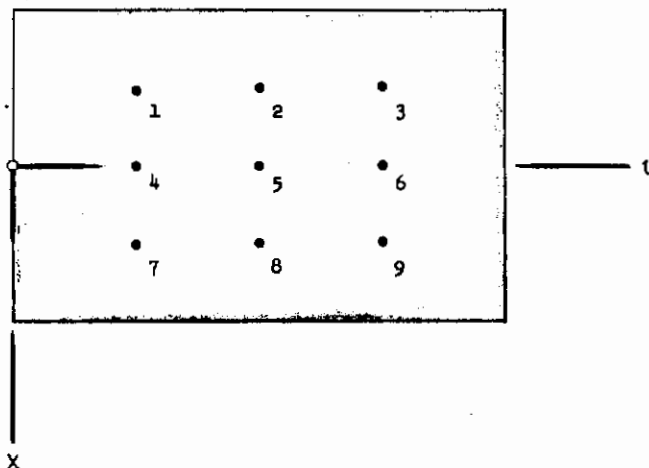

FIGURE 17 COLLOCATION POINTS FOR SIMPLY-SUPPORTED PLATE

Equations 2-477 and 2-489 then become

$$\tau = \frac{1}{2} \{p\}' [A] \{p\} \quad (2-492)$$

and

$$u = \frac{1}{2} \{p\}' [K] \{p\} \quad (2-493)$$

where

$$[A] = \sum_{i=1}^{N \cdot M} [\tau]_i' [A]_i [\tau]_i \quad (2-494)$$

and

$$[K] = \sum_{i=1}^{N \cdot M} [\tau]_i' [K]_i [\tau]_i \quad (2-495)$$

Contrails

For this problem the inertia and stiffness matrices are 9 by 9. The influence coefficients are given by

$$[E] = [K]^{-1} \quad (2-496)$$

These matrices are listed in Tables 6 and 7 for a steel plate ($\nu = 0.3$) with $L/b = 3$. The following tables compare the frequencies calculated from the equation,

$$[E][A]\{\varphi\} = \lambda\{\varphi\} \quad (2-497)$$

with the "exact" solutions¹.

TABLE 4 FREQUENCIES OF SIMPLY - SUPPORTED PLATE, $L/b = 3$, $\nu = 0.3$, DIPARABOLIC COLLOCATION

$\frac{\omega_i^2 mL^4}{EI}$	$i = 1$	$i = 2$	$i = 3$	$i = 4$	$i = 5$
	1,098	4,378	11,827	16,316	19,600

TABLE 5 FREQUENCIES OF SIMPLY - SUPPORTED PLATE, $L/b = 3$, EXACT SOLUTION

$\frac{\omega_i^2 mL^4}{EI}$	$i = 1$	$i = 2$	$i = 3$	$i = 4$	$i = 5$
	1,029	3,805	9,740	12,328	15,585

¹The exact solutions are obtained from Timoshenko and Woinowsky-Krieger; Theory of Plates and Shells, McGraw-Hill, 1959, Section 28, by using equation (g) on page 335.

TABLE 6 INFLUENCE MATRIX FOR A SIMPLY - SUPPORTED PLATE

1.413	0.904	0.364	1.355	1.109	0.487	0.740	0.708	0.337	} × 10 ⁻³
0.904	1.806	0.904	1.12	1.846	1.112	0.708	1.080	0.708	
0.364	0.904	1.413	0.487	1.109	1.355	0.337	0.708	0.740	
1.355	1.12	0.487	2.13	1.57	0.683	1.355	1.12	0.487	
1.109	1.846	1.109	1.568	2.811	1.568	1.109	1.846	1.109	
0.487	1.12	1.355	0.683	1.568	2.129	9.487	1.12	1.355	
0.740	0.708	0.337	1.355	1.109	0.487	1.413	0.904	0.364	
0.708	1.080	0.708	1.12	1.846	1.12	0.904	1.806	0.904	
0.337	0.708	0.740	0.487	1.109	1.355	0.364	0.904	1.413	

TABLE 7 INERTIA MATRIX FOR A SIMPLY - SUPPORTED PLATE

1.953	0.251	-0.079	0.251	0.031	-0.010	-0.079	-0.010	0.003	} × 10 ⁻¹
0.251	1.811	0.251	0.031	0.227	0.031	-0.010	0.072	-0.010	
-0.079	0.251	1.953	-0.010	0.031	0.251	0.003	-0.010	-0.079	
0.251	0.031	-0.010	1.811	0.227	-0.072	0.251	0.031	-0.010	
0.031	0.227	0.031	0.227	1.66	0.227	0.031	0.227	0.031	
-0.010	0.031	0.251	-0.072	0.227	1.811	-0.010	0.031	0.251	
-0.079	-0.010	0.003	0.251	0.031	-0.010	1.953	0.251	-0.079	
-0.010	0.072	-0.010	0.031	0.227	0.031	0.251	1.81	0.251	
0.003	-0.010	-0.079	-0.010	0.031	0.251	-0.079	0.251	1.953	

2.3.3.3 The Vibration of a Uniform Thin Ring

In the general development and also in the specific problems we have considered, it has been convenient to use rectangular coordinates, (x,y,z), as the Lagrangian particle variables. For a thin ring, however, the geometry is better suited to a set of cylindrical coordinates for use as Lagrangian variables. For this purpose, we introduce (r, θ, x) such that

Contrails

$$\begin{aligned} x &= r \cos \theta \\ y &= r \sin \theta \\ z &= r \cos \theta \end{aligned} \quad (2-498)$$

The specific internal energy for a particle of a thin ring is then

$$u(r, \theta, x, t) = \frac{1}{2} \frac{E}{1-\gamma^2} \epsilon_{\theta\theta}^2 \quad (2-499)$$

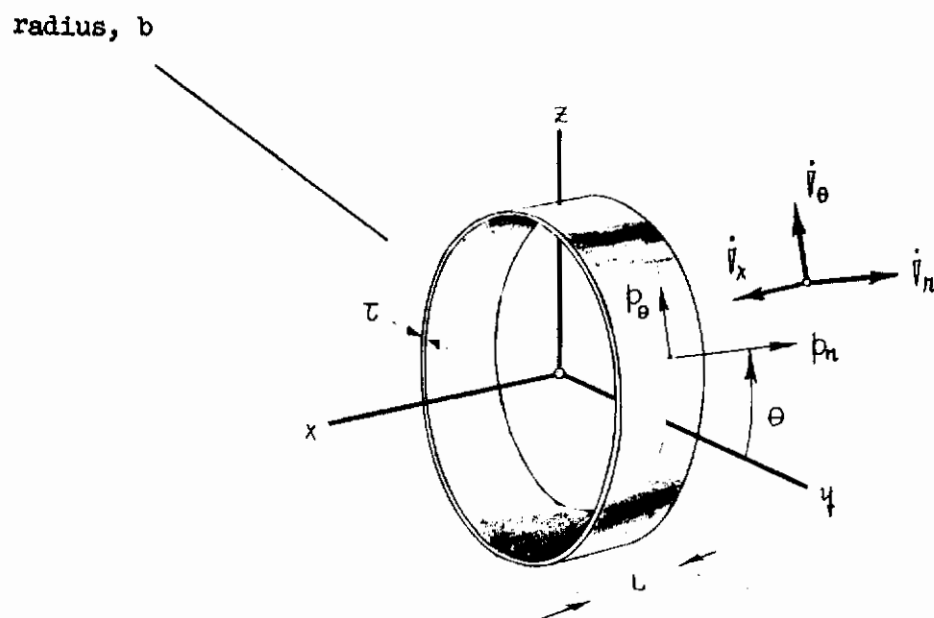

FIGURE 18 UNIFORM THIN RING

A position vector for the r- θ -x particle is

$$r(r, \theta, x, t) = L(r, \theta, x) + p(\theta, t) \quad (2-500)$$

where

$$\mathbf{p} = p_r(\theta, t) \hat{r}_r + p_\theta(\theta, t) \hat{r}_\theta \quad (2-501)$$

The strain is related to the tangential and radial components of displacement by

$$\epsilon_{\theta\theta} = \frac{1}{r} \left(\frac{\partial p_\theta}{\partial \theta} + p_r \right) - \frac{(r-b)}{r^2} \left(\frac{\partial^2 p_r}{\partial \theta^2} + \frac{\partial p_\theta}{\partial \theta} \right) \quad (2-502)$$

The total strain energy is

$$\begin{aligned} U &= \int u dV & (2-503) \\ &= \frac{1}{2} \int_0^{2\pi} \int_0^L \int_{b-\frac{\tau}{2}}^{b+\frac{\tau}{2}} \frac{E}{1-\nu^2} \left(\frac{1}{r} \left(\frac{\partial p_\theta}{\partial \theta} + p_r \right) - \frac{(r-b)}{r^2} \left(\frac{\partial^2 p_r}{\partial \theta^2} + \frac{\partial p_\theta}{\partial \theta} \right) \right)^2 t dr dx d\theta \\ &= \frac{1}{2} \int_0^{2\pi} \frac{EL}{1-\nu^2} \left(\frac{\tau}{r^2} \left(\frac{\partial p_\theta}{\partial \theta} + p_r \right)^2 + \frac{\tau^3}{12b^4} \left(\frac{\partial^2 p_r}{\partial \theta^2} + \frac{\partial p_\theta}{\partial \theta} \right)^2 \right) t d\theta \\ &= \underbrace{\frac{1}{2} \int_0^{2\pi} \frac{E\tau^3 L}{12(1-\nu^2)} \left(\frac{\partial^2 p_r}{\partial \theta^2} + \frac{\partial p_\theta}{\partial \theta} \right)^2 t d\theta}_{\text{bending energy}} + \underbrace{\frac{1}{2} \int_0^{2\pi} \frac{EL\tau}{(1-\nu^2)} \left(\frac{\partial p_\theta}{\partial \theta} + \frac{p_r}{r} \right)^2 t d\theta}_{\text{tensile energy}} \end{aligned}$$

The total kinetic energy is

$$\begin{aligned}
 T &= \frac{1}{2} \int \rho \frac{\partial \pi}{\partial t} \cdot \frac{\partial \pi}{\partial t} dV & (2-504) \\
 &= \frac{1}{2} \int_0^{2\pi} \int_0^L \int_{t-\tau/2}^{t+\tau/2} \rho \left(\left(\frac{\partial \pi}{\partial t} \right)^2 + \left(\frac{\partial \pi}{\partial t} \right)^2 \right) t dx d\theta \\
 &= \frac{1}{2} \int_0^{2\pi} \rho \tau L \left(\left(\frac{\partial \pi}{\partial t} \right)^2 + \left(\frac{\partial \pi}{\partial t} \right)^2 \right) t d\theta
 \end{aligned}$$

Let the circumferential length be divided into N equal segments each of arc length,

$$w = \frac{2\pi t}{N} \quad (2-505)$$

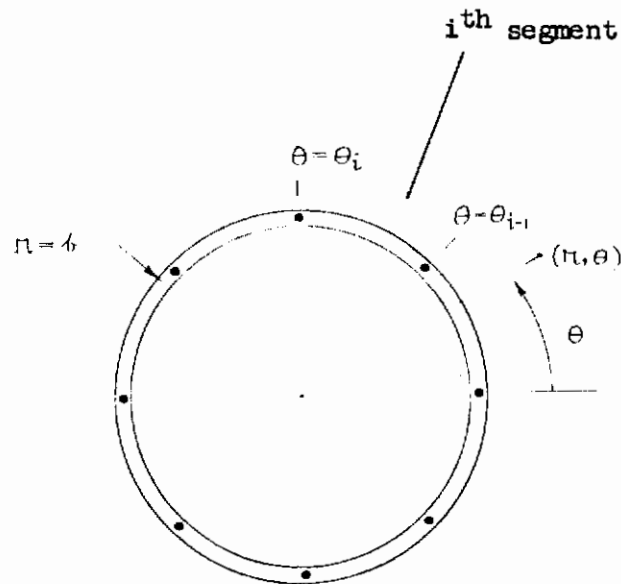

FIGURE 19 COLLOCATION POINTS

Contrails

The location of the i^{th} collocation point is given by

$$\theta = \theta_i = \frac{2\pi}{N} i \quad (2-506)$$

We then write Equation 2-504 as

$$T = \frac{1}{2} \sum_{i=1}^N \int_{\theta_{i-1}}^{\theta_i} \rho \tau L \left(\left(\frac{\partial p_r}{\partial t} \right)^2 + \left(\frac{\partial p_\theta}{\partial t} \right)^2 \right) b d\theta \quad (2-507)$$

and introduce a local variable, η , such that

$$\eta = \frac{b\theta - b\theta_i}{w} \quad (2-508)$$

Then, in Equation 2-507, we make the change of variable

$$b\theta = w\eta + b\theta_i \quad (2-509)$$

$$T = \frac{1}{2} \sum_{i=1}^N \int_0^1 m \left(\left(\frac{\partial p_r}{\partial t} \right)^2 + \left(\frac{\partial p_\theta}{\partial t} \right)^2 \right) w d\eta \quad (2-510)$$

where

$$m = \rho \tau L \quad (2-511)$$

If we define

$$p_r^{(i)}(t) = p_r(\theta_i, t) \quad (2-512)$$

and

$$p_\theta^{(i)}(t) = p_\theta(\theta_i, t) \quad (2-513)$$

Contrails

then we may approximate the functions $p_r(\theta, t)$ and $p_\theta(\theta, t)$ by use of the diparabolic formula.

$$p_r(\theta, t) = \{ \eta \eta^t \eta^3 \} [J] \{ p_r \}_i \quad (2-514)$$

$$p_\theta(\theta, t) = \{ \eta \eta^2 \eta^3 \} [J] \{ p_\theta \}_i \quad (2-515)$$

for $\theta_{i-1} \leq \theta \leq \theta_i$

where (see Equation 2-388)

$$[J] = \begin{bmatrix} 0 & 1 & 0 & 0 \\ -\frac{1}{2} & 0 & \frac{1}{2} & 0 \\ 1 & -\frac{3}{2} & 2 & -\frac{1}{2} \\ -\frac{1}{2} & \frac{3}{2} & -\frac{3}{2} & \frac{1}{2} \end{bmatrix} \quad (2-516)$$

for every interval, and

$$\{ p_r \}_i = \begin{bmatrix} p_r^{(i-2)} \\ p_r^{(i-1)} \\ p_r^{(i)} \\ p_r^{(i+1)} \end{bmatrix} \quad \{ p_\theta \}_i = \begin{bmatrix} p_\theta^{(i-2)} \\ p_\theta^{(i-1)} \\ p_\theta^{(i)} \\ p_\theta^{(i+1)} \end{bmatrix} \quad (2-517)$$

Substitution into Equation 2-510 gives

$$T = \frac{1}{2} \sum_{i=1}^N \left(\{ p_r \}'_i [A_{rr}]_i \{ p_r \}_i + \{ p_\theta \}'_i [A_{\theta\theta}]_i \{ p_\theta \}_i \right) \quad (2-518)$$

Contrails

where

$$[A_{nr}]_i = [A_{\theta\theta}]_i = [J]' \int_0^1 m \begin{bmatrix} 1 \\ \eta \\ \eta^2 \\ \eta^3 \end{bmatrix} \{ 1 \ \eta \ \eta^2 \ \eta^3 \} w d\eta [J] \quad (2-519)$$

$$= \frac{mW}{6720} \begin{bmatrix} 16 & -168 & -120 & 12 \\ -168 & 2720 & 1228 & -120 \\ -120 & 1228 & 2720 & -168 \\ 12 & -120 & -168 & 16 \end{bmatrix} \quad \begin{array}{l} \text{for all } i, \\ i = 1, 2, \dots, N \end{array}$$

For the strain energy, we have

$$U = \frac{1}{2} \sum_{i=1}^N \int_0^1 EI \left(\frac{1}{w^2} \frac{\partial^2 p_n}{\partial \eta^2} + \frac{1}{wb} \frac{\partial p_\theta}{\partial \eta} \right)^2 w d\eta + \int_0^1 \frac{E L I}{1-\nu^2} \left(\frac{1}{w} \frac{\partial p_\theta}{\partial \eta} + \frac{p_n}{b} \right)^2 w d\eta \quad (2-520)$$

$$= \frac{1}{2} \sum_{i=1}^N \int_0^1 EI \left(\frac{1}{w^2} \left(\frac{\partial^2 p_n}{\partial \eta^2} + \frac{w}{b} \frac{\partial p_\theta}{\partial \eta} \right)^2 + \frac{12}{E^2 w} \left(\frac{\partial p_\theta}{\partial \eta} + \frac{w}{b} p_n \right)^2 \right) d\eta$$

where

$$EI = \frac{E r^2 I}{12(1-\nu^2)} \quad (2-521)$$

and from Equation 2-505,

$$\frac{w}{b} = \frac{2r}{\sqrt{3}} \quad (2-522)$$

Using Equations 2-514 and 2-515, we have

$$\frac{\partial p_\theta}{\partial \eta} + \frac{w}{b} p_n = \{ 0 \ 2\eta \ 3\eta^2 \} [J] \{ p_\theta \}_i + \frac{2r}{N} \{ 1 \ \eta \ \eta^2 \ \eta^3 \} [J] \{ p_n \}_i \quad (2-523)$$

Contrails

and

$$\frac{\partial^2 p_n}{\partial \eta^2} + \frac{w}{t} \frac{\partial p_n}{\partial \eta} = \{0 \ 0 \ 2 \ 6\eta\} [J] \{p_n\}_i + \frac{2\pi}{N} \{0 \ 1 \ 2\eta \ 3\eta^2\} [J] \{p_\theta\}_i \quad (2-524)$$

Substituting these into the strain energy, we obtain

$$U = \frac{1}{2} \sum_{i=1}^N \{p_n\}_i' [K_{nn}]_i \{p_n\}_i + 2 \{p_n\}_i' [K_{n\theta}]_i \{p_\theta\}_i + \{p_\theta\}_i' [K_{\theta\theta}]_i \{p_\theta\}_i \quad (2-525)$$

where

$$[K_{nn}]_i = [J]' \left(\int_0^1 \frac{EI}{w^3} \begin{bmatrix} 0 \\ 0 \\ 2 \\ 6\eta \end{bmatrix} \{0 \ 0 \ 2 \ 6\eta\} d\eta + \int_0^1 \frac{EI}{w^3} 12 \left(\frac{t}{L}\right)^2 \left(\frac{2\pi}{N}\right)^4 \begin{bmatrix} 1 \\ \eta \\ \eta^2 \\ \eta^3 \end{bmatrix} \{1 \ \eta \ \eta^2 \ \eta^3\} d\eta \right) [J] \quad (2-526)$$

$$[K_{n\theta}]_i = [J]' \left(\int_0^1 \frac{EI}{w^3} \left(\frac{2\pi}{N}\right) \begin{bmatrix} 0 \\ 0 \\ 2 \\ 6\eta \end{bmatrix} \{0 \ 0 \ 2 \ 6\eta\} d\eta + \int_0^1 \frac{EI}{w^3} 12 \left(\frac{t}{L}\right)^2 \left(\frac{2\pi}{N}\right)^3 \begin{bmatrix} 1 \\ \eta \\ \eta^2 \\ \eta^3 \end{bmatrix} \{1 \ \eta \ \eta^2 \ \eta^3\} d\eta \right) [J] \quad (2-527)$$

$$[K_{\theta\theta}]_i = [J]' \left(\int_0^1 \frac{EI}{w^3} \left(1 + 12 \frac{t^2}{L^2}\right) \left(\frac{2\pi}{N}\right)^2 \begin{bmatrix} 0 \\ 1 \\ 2\eta \\ 3\eta^2 \end{bmatrix} \{0 \ 1 \ 2\eta \ 3\eta^2\} d\eta \right) [J] \quad (2-528)$$

If the definite integral in these expressions is evaluated and the matrix products are evaluated, the following numerical results are obtained

$$[K_{nn}]_i = \frac{EI}{w^3} \left(\frac{1}{4} \begin{bmatrix} 4 & -10 & 8 & -2 \\ -10 & 28 & -26 & 8 \\ 8 & -26 & 28 & -10 \\ -2 & 8 & -10 & 4 \end{bmatrix} + \frac{12 \left(\frac{t}{L}\right)^2 \left(\frac{2\pi}{N}\right)^4}{6720} \begin{bmatrix} 16 & -108 & -120 & 12 \\ -108 & 2720 & 1228 & -120 \\ -120 & 1228 & 2720 & -108 \\ 12 & -120 & -108 & 16 \end{bmatrix} \right) \quad (2-529)$$

Contrails

$$[K_{1\theta}]_i = \frac{EI}{W^3} \left(\frac{1}{16} \begin{bmatrix} -1 & -3 & 5 & -1 \\ 3 & 1 & 7 & 3 \\ -3 & 7 & -1 & -3 \\ 1 & -5 & 3 & 1 \end{bmatrix} + \frac{12(\frac{L}{\xi})^2(\frac{2\pi}{N})^3}{240} \begin{bmatrix} 0 & 11 & -12 & 1 \\ -11 & -120 & 143 & -12 \\ 12 & -140 & 120 & 11 \\ -1 & 12 & -11 & 0 \end{bmatrix} \right) \quad (2-530)$$

$$[K_{\theta\theta}]_i = \frac{EI}{W^3} \frac{(1 + 12(\frac{L}{\xi})^2)(\frac{2\pi}{N})^2}{120} \begin{bmatrix} 4 & -7 & 2 & 1 \\ -7 & 136 & -131 & 2 \\ 2 & -131 & 136 & -7 \\ 1 & 2 & -7 & 4 \end{bmatrix} \quad (2-531)$$

Finally, we introduce the definitions

$$\begin{bmatrix} \{b_n\}_i \\ \{b_\theta\}_i \end{bmatrix} = [T]_i \{b\} \quad (2-532)$$

in which we identify (see Figure 20),

$$\theta_{-1} = \theta_{N-1} \quad (2-533)$$

$$\theta_{N+1} = \theta_1 \quad (2-534)$$

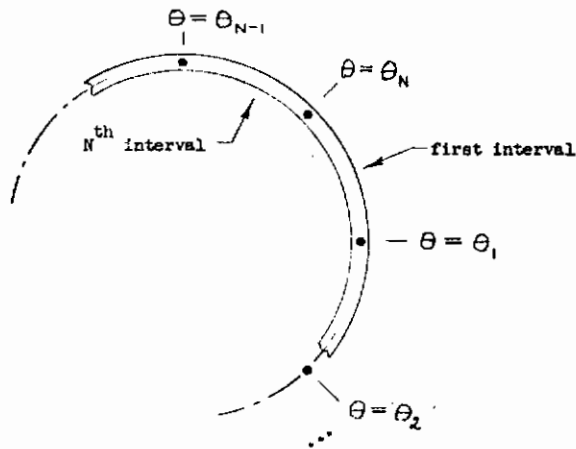

FIGURE 20 RELATION BETWEEN THE FIRST AND LAST INTERVAL

If we define,

$$\{p\} = \begin{bmatrix} p_r^{(1)} \\ p_r^{(2)} \\ \vdots \\ p_r^{(N)} \\ p_e^{(1)} \\ p_e^{(2)} \\ \vdots \\ p_e^{(N)} \end{bmatrix} \quad (2-535)$$

then

$$\tau = \frac{1}{2} \{p\}' [A] \{p\} \quad (2-536)$$

Contrails

and

$$U = \frac{1}{2} \{p\}^T [K] \{p\} \quad (2-537)$$

where

$$[A] = \sum_{i=1}^N [T]_i^T \begin{bmatrix} [A_{\pi\pi}]_i & [0] \\ [0] & [A_{\theta\theta}]_i \end{bmatrix} [T]_i \quad (2-538)$$

and

$$[K] = \sum_{i=1}^N [T]_i^T \begin{bmatrix} [K_{\pi\pi}]_i & [K_{\pi\theta}]_i \\ [K_{\pi\theta}]_i^T & [K_{\theta\theta}]_i \end{bmatrix} [T]_i \quad (2-539)$$

It can be verified that there are three zero-frequency modes for the unrestrained ring which represent displacements of the ring as a rigid body. These modes can be taken as:

$$\{\varphi_R\}_1 = \begin{bmatrix} 0 \\ 0 \\ \vdots \\ 0 \\ \vdots \\ \vdots \\ \vdots \\ 1 \end{bmatrix} \quad \{\varphi_R\}_2 = \begin{bmatrix} \cos \theta_1 \\ \cos \theta_2 \\ \vdots \\ \cos \theta_N \\ -\sin \theta_1 \\ -\sin \theta_2 \\ \vdots \\ -\sin \theta_N \end{bmatrix} \quad \{\varphi_R\}_3 = \begin{bmatrix} -\sin \theta_1 \\ -\sin \theta_2 \\ \vdots \\ -\sin \theta_N \\ \cos \theta_1 \\ \cos \theta_2 \\ \vdots \\ \cos \theta_N \end{bmatrix} \quad (2-540)$$

The first represents a unit rotation while the last two represent unit translations in the y and z directions.

The solution to the eigenvalue problem,

$$(-\omega^2 [A] + [K]) \{\varphi\} = \{0\} \quad (2-541)$$

Contrails

follows that outlined in Paragraph 2.2.3.4. For $N = 8$, ($\frac{2\pi}{4} = 0.78539816$) the following results are obtained

$$[A_{\Pi\Pi}] = [A_{\Theta\Theta}] = \frac{\pi 2\pi^{1/2}}{6720} \begin{bmatrix} 5472 & 852 & -240 & 12 & 0 & 12 & -240 & 852 \\ 852 & 5472 & 852 & -240 & 12 & 0 & 12 & -240 \\ -240 & 852 & 5472 & 852 & -240 & 12 & 0 & 12 \\ 12 & -240 & 852 & 5472 & 852 & -240 & 12 & 0 \\ 0 & 12 & -240 & 852 & 5472 & 852 & -240 & 12 \\ 12 & 0 & 12 & -240 & 852 & 5472 & 852 & -240 \\ -240 & 12 & 0 & 12 & -240 & 852 & 5472 & 852 \\ 852 & -240 & 12 & 0 & 12 & -240 & 852 & 5472 \end{bmatrix} \quad (2-542)$$

$$[K_{\Pi\Pi}] = \frac{EI 512}{4(2\pi b)^3} \begin{bmatrix} 64 & -46 & 16 & -2 & 0 & -2 & 16 & -46 \\ -46 & 64 & -46 & 16 & -2 & 0 & -2 & 16 \\ 16 & -46 & 64 & -46 & 16 & -2 & 0 & -2 \\ -2 & 16 & -46 & 64 & -46 & 16 & -2 & 0 \\ 0 & -2 & 16 & -46 & 64 & -46 & 16 & -2 \\ -2 & 0 & -2 & 16 & -46 & 64 & -46 & 16 \\ 16 & -2 & 0 & -2 & 16 & -46 & 64 & -46 \\ -46 & 16 & -2 & 0 & -2 & 16 & -46 & 64 \end{bmatrix} \quad (2-543)$$

$$[K_{\Theta\Theta}] = \frac{EI 512}{(2\pi b)^3 16} \begin{bmatrix} 0 & -13 & 8 & -1 & 0 & 1 & -8 & 13 \\ 13 & 0 & -13 & 8 & -1 & 0 & 1 & -8 \\ -8 & 13 & 0 & -13 & 8 & -1 & 0 & 1 \\ 1 & -8 & 13 & 0 & -13 & 8 & -1 & 0 \\ 0 & 1 & -8 & 13 & 0 & -13 & 8 & -1 \\ -1 & 0 & 1 & -8 & 13 & 0 & -13 & 8 \\ 8 & -1 & 0 & 1 & -8 & 13 & 0 & -13 \\ -13 & 8 & -1 & 0 & 1 & -8 & 13 & 0 \end{bmatrix} + \frac{EI 512}{(2\pi b)^3 6720} 12 \left(\frac{4}{\tau}\right)^2 \left(\frac{2\pi}{8}\right)^4 \begin{bmatrix} 5472 & 852 & -240 & 12 & 0 & 12 & -240 & 852 \\ 852 & 5472 & 852 & -240 & 12 & 0 & 12 & -240 \\ -240 & 852 & 5472 & 852 & -240 & 12 & 0 & 12 \\ 12 & -240 & 852 & 5472 & 852 & -240 & 12 & 0 \\ 0 & 12 & -240 & 852 & 5472 & 852 & -240 & 12 \\ 12 & 0 & 12 & -240 & 852 & 5472 & 852 & -240 \\ -240 & 12 & 0 & 12 & -240 & 852 & 5472 & 852 \\ 852 & -240 & 12 & 0 & 12 & -240 & 852 & 5472 \end{bmatrix} \quad (2-544)$$

$$+ \frac{EI 512}{(2\pi b)^3 240} 12 \left(\frac{4}{\tau}\right)^2 \left(\frac{2\pi}{8}\right)^3 \begin{bmatrix} 0 & 165 & -24 & 1 & 0 & -1 & 24 & -165 \\ -165 & 0 & 165 & -24 & 1 & 0 & -1 & 24 \\ 24 & -165 & 0 & 165 & -24 & 1 & 0 & -1 \\ -1 & 24 & -165 & 0 & 165 & -24 & 1 & 0 \\ 0 & -1 & 24 & -165 & 0 & 165 & -24 & 1 \\ 1 & 0 & -1 & 24 & -165 & 0 & 165 & -24 \\ -24 & 1 & 0 & -1 & 24 & -165 & 0 & 165 \\ 165 & -24 & 1 & 0 & -1 & 24 & -165 & 0 \end{bmatrix}$$

$$[K_{\Theta\Theta}] = \frac{EI 512}{(2\pi b)^3} \frac{(1 + 12(\frac{4}{\tau})^2)(\frac{2\pi}{N})^2}{120} \begin{bmatrix} 280 & -145 & 4 & 1 & 0 & 1 & 4 & -145 \\ -145 & 280 & -145 & 4 & 1 & 0 & 1 & 4 \\ 4 & -145 & 280 & -145 & 4 & 1 & 0 & 1 \\ 1 & 4 & -145 & 280 & -145 & 4 & 1 & 0 \\ 0 & 1 & 4 & -145 & 280 & -145 & 4 & 1 \\ 1 & 0 & 1 & 4 & -145 & 280 & -145 & 4 \\ 4 & 1 & 0 & 1 & 4 & -145 & 280 & -145 \\ -145 & 4 & 1 & 0 & 1 & 4 & -145 & 280 \end{bmatrix} \quad (2-545)$$

2.3.3.4 The Analysis of Structures with Nonuniform Properties

When the inertia and stiffness properties of the structure are nonuniform, then integrals like those in Equations 2-419, 2-420, 2-478, 2-519, 2-526, 2-527, and 2-528 must be evaluated by some numerical process. This may easily be done with the aid of a digital computer by using, for example, a Simpson's rule integration. Another alternative is to use an approximate method based on the mean value theorem. To illustrate, consider Equation 2-419 in the case where $m(x)$ is not constant.

$$[A]_i = [J]_i \int_0^l m(x) \begin{bmatrix} 1 & x & x^2 & x^3 \\ x & x^2 & x^3 & x^4 \\ x^2 & x^3 & x^4 & x^5 \\ x^3 & x^4 & x^5 & x^6 \end{bmatrix} dx [J]_i \quad (2-546)$$

By the mean value theorem for integrals, there are values of $m(x)$ in the interval $x_{i-1} \leq x \leq x_i$ such that

$$\int_0^l m(x) dx = m_i \int_0^l dx = m_i l \quad (2-547)$$

$$\int_0^l m(x) x dx = m_i^{(1)} \int_0^l x dx = \frac{1}{2} m_i^{(1)} l^2 \quad (2-548)$$

$$\int_0^l m(x) x^2 dx = m_i^{(2)} \int_0^l x^2 dx = \frac{1}{3} m_i^{(2)} l^3 \quad (2-549)$$

$$\vdots$$

$$\int_0^l m(x) x^6 dx = m_i^{(6)} \int_0^l x^6 dx = \frac{1}{7} m_i^{(6)} l^7 \quad (2-550)$$

From Equation 2-547 we note that m_i is the average value of $m(x)$ on the interval, $x_{i-1} \leq x \leq x_i$. On the basis that $m(x)$ is a "slowly" varying function, we may make the approximation

$$m_i^{(1)} = m_i^{(2)} = \dots = m_i^{(6)} = m_i \quad (2-551)$$

We then have

$$[A]_i = [J]_i m_i l \begin{bmatrix} 1 & \frac{1}{2} & \frac{1}{3} & \frac{1}{4} \\ \frac{1}{2} & \frac{1}{3} & \frac{1}{4} & \frac{1}{5} \\ \frac{1}{3} & \frac{1}{4} & \frac{1}{5} & \frac{1}{6} \\ \frac{1}{4} & \frac{1}{5} & \frac{1}{6} & \frac{1}{7} \end{bmatrix} [J]_i \quad (2-552)$$

Contrails

which reduces to Equation 2-421 with m replaced by m_1 . This approximation is not good when there are "concentrated" mass items, but these can be considered separately, on the basis that they act like Dirac delta-functions. Say, for example, that

$$m(x) = m + m_k \delta(x-x_k) \quad (2-553)$$

that is, $m(x)$ is constant with the exception of a single concentrated mass, m_k , at $x = x_k$. $\delta(x)$ is the Dirac "function" with the property

$$\int \delta(x-x_k) f(x) dx = f(x_k) \quad (2-554)$$

in this case Equation 2-546 becomes

$$[A]_i = [J]_i \left(\ell m \int_0^1 \begin{bmatrix} 1 & \xi & \xi^2 & \xi^3 \\ \xi & \xi^2 & \xi^3 & \xi^4 \\ \xi^2 & \xi^3 & \xi^4 & \xi^5 \\ \xi^3 & \xi^4 & \xi^5 & \xi^6 \end{bmatrix} d\xi + m_k \int_0^1 \delta(\xi-\xi_k) \begin{bmatrix} 1 & \xi & \xi^2 & \xi^3 \\ \xi & \xi^2 & \xi^3 & \xi^4 \\ \xi^2 & \xi^3 & \xi^4 & \xi^5 \\ \xi^3 & \xi^4 & \xi^5 & \xi^6 \end{bmatrix} d\xi \right) [J]_i \quad (2-555)$$

where

$$\xi_k = \frac{x_k - x_{i-1}}{\ell} \quad (2-556)$$

Using the property described in Equation 2-554, we have

$$[J]_i m_k \begin{bmatrix} 1 & \xi_k & \xi_k^2 & \xi_k^3 \\ \xi_k & \xi_k^2 & \xi_k^3 & \xi_k^4 \\ \xi_k^2 & \xi_k^3 & \xi_k^4 & \xi_k^5 \\ \xi_k^3 & \xi_k^4 & \xi_k^5 & \xi_k^6 \end{bmatrix} [J]_i \quad (2-557)$$

as the contribution to $[A]_i$ from the concentrated mass at $x = x_k$.

In a practical case the actual distribution, $m(x)$, can be broken down into two parts: one is a slowly varying part which can be approximated as in Equation 2-522; the second is a part which can be idealized as a concentrated item. Figure 21 is a typical example

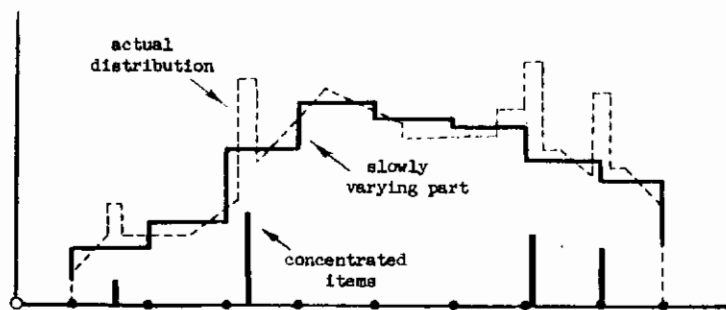

FIGURE 21 APPROXIMATION TO DISTRIBUTION OF STRUCTURAL PROPERTIES

Contrails

3.0 METHODS IN DYNAMICS AND AEROELASTICITY
FOR
SLENDER LAUNCH VEHICLES IN PLANE MOTION

Contrails

3.1 THE LINEAR AEROELASTIC EQUATIONS GOVERNING THE SMALL LATERAL MOTIONS OF A SLENDER LAUNCH VEHICLE

Most aspects of launch vehicle dynamics are adequately described by a set of linear equations. The linear analyses also form a firm conceptual basis for the understanding of dynamics problems involving nonlinearities. Traditionally, nonlinear dynamic analyses have only been considered in missile performance where the determination of the trajectory has assumed the missile to be rigid. There has been some question, in the past, whether the linear equations, in terms of small motions from an inertial-axis, are equivalent to a set of nonlinear body-axis equations which have been linearized. This question is of fundamental importance in the discussion of Section 3.2. In this section, however, we will review the methods of aeroelastic analysis for small motions from an inertial frame-of-reference¹.

For the purposes of illustration, we will confine our attentions to the dynamics of a slender launch vehicle whose aeroelastic properties are sufficiently described as functions of a single coordinate, x , measured from the nose of the missile and considered positive in the aft direction. We will also assume that there is a mechanism for control and guidance. This might be a gimballed engine, jet vane, and/or aerodynamic control. We will assume, however, that it is an aerodynamic control device for the purposes of concentrating on the method of analysis. Further we will assume that the control surface is rigid. Many of the assumptions made in this section are not essential but are made only to simplify the preliminary discussion. It is an advantage of the methods of Analytical Mechanics that many of the derived relations are independent of the geometry of the particular system being considered.

3.1.1 The Kinetic and Potential Energy and the Virtual Work of Aerodynamics and Servo Forces

3.1.1.1 The Calculation of Basic Data for a Slender Controlled Vehicle

3.1.1.1.1 The Kinetic Energy

If we let the displacement of the axis of the missile (from an inertial frame) be denoted by $p_z(x,t)$, the kinetic energy of the missile is

$$T = \frac{1}{2} \int_0^L m(x) \left(\frac{\partial p_z}{\partial t} \right)^2 dx \quad (3-1)$$

where

$m(x)$ = mass/unit of length along the vehicle

¹In order to distinguish the linear analyses from the flexible-body trajectory analyses described in Section 3.2, the term "time-slice analysis" is coming into common use. The advantages and disadvantages of both the "time-slice" and "flexible-trajectory" analyses were recently aired in a NASA informal conference on Winds Aloft and Application to Launch Vehicle Design held at Langley Research Center April 22-23, 1964 (Proceedings not suitable for referencing).

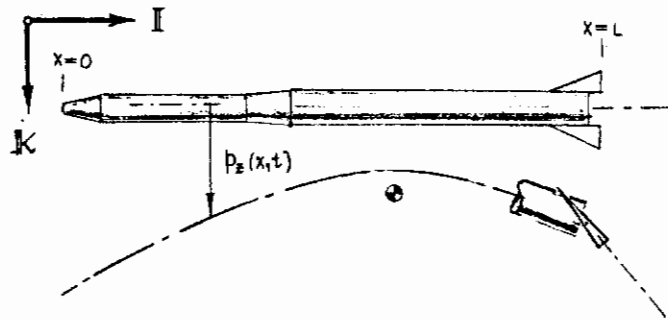

FIGURE 22 SLENDER CONTROLLED VEHICLE

Using the interpolation methods developed in Section 2.3, we may divide the missile into a number of intervals or "bays" and approximate the continuous displacement curve, p_z , by displacements at discrete points. The result may be expressed as (see Paragraph 2.3.3.1, Equation 2-404).

$$p_z(x,t) = \{1 \ \xi \ \xi^2 \ \xi^3\} [\mathcal{J}]_i [\mathcal{T}]_i \{p\} \quad (3-2)$$

$$\text{for } x_{i-1} \leq x \leq x_i$$

Substituting these expressions into the kinetic energy, we obtain

$$T = \frac{1}{2} \{p\}' [A] \{p\} \quad (3-3)$$

where

$$[A] = \sum_{i=1}^N [\mathcal{T}]_i' [\mathcal{J}]_i' \int_{x_{i-1}}^{x_i} m(x) \begin{bmatrix} 1 \\ \xi \\ \xi^2 \\ \xi^3 \end{bmatrix} \{1 \ \xi \ \xi^2 \ \xi^3\} dx [\mathcal{J}]_i [\mathcal{T}]_i \quad (3-4)$$

Figure 23 shows a typical mass distribution for a slender launch vehicle.

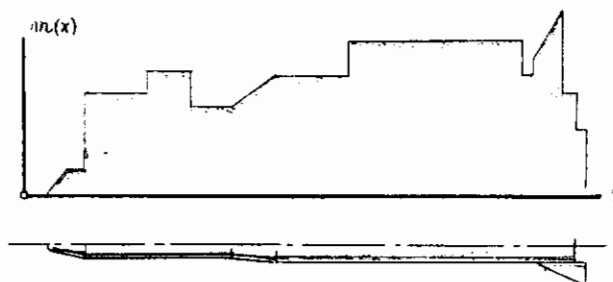

FIGURE 23 MASS DISTRIBUTION FOR A SLENDER LAUNCH VEHICLE

3.1.1.1.2 The Strain Energy

The strain energy in bending is

$$U = \frac{1}{2} \int_0^L EI(x) \left(\frac{\partial^2 p_z}{\partial x^2} \right)^2 dx \quad (3-5)$$

where $EI(x)$ is the bending rigidity of the missile¹. The interpolation procedure may also be used to express this in terms of a finite number of degrees-of-freedom.

$$\int_0^L EI(x) \left(\frac{\partial^2 p_z}{\partial x^2} \right)^2 dx = \{p\}' [K] \{p\} \quad (3-6)$$

The total strain energy is then

$$U = \frac{1}{2} \{p\}' [K] \{p\} \quad (3-7)$$

where $[K]$ is the unrestrained, "free-free," stiffness matrix,

$$[K] = \sum_{i=1}^N [\tau]'_i [\mathcal{J}]'_i \int_{x_{i-1}}^{x_i} EI(x) \begin{bmatrix} 0 & 0 & 2 & 6x \\ 0 & 2 & 6x & 6 \\ 2 & 6x & 6 & 6x \\ 6x & 6 & 6x & 6 \end{bmatrix} \frac{1}{2l_i} dx [\mathcal{J}]_i [\tau]_i \quad (3-8)$$

¹The effect of axial loads is discussed in Paragraph 3.1.2.5. The effect of shear energy and rotary inertia is considered in Paragraph 5.2.2.1. Also, it must be noted that the "complementary energy" techniques give much more accurate results than the diparabolic interpolation (see Paragraph 5.2.1). The method is only used here for its conceptual simplicity.

Figure 24 shows a typical bending rigidity distribution for a slender launch vehicle

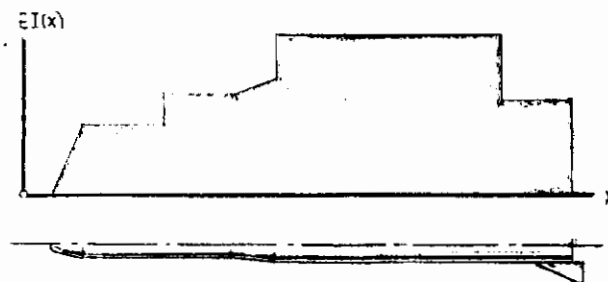

FIGURE 24 BENDING RIGIDITY DISTRIBUTION FOR A SLENDER LAUNCH VEHICLE

3.1.1.1.3 Aerodynamic Forces

For the purposes of illustration we shall assume that the aerodynamic forces can be described by the following expression.

$$L(x,t) = \frac{1}{2} \rho a V_\infty^2 \frac{\partial C_L}{\partial \alpha}(x) \alpha(x,t) \quad (3-9)$$

where $L(x,t)$ is the lift (positive "up") per unit of length along the missile; $\frac{1}{2} \rho a V_\infty^2$ is the free stream dynamic pressure; and

$$\frac{\partial C_L}{\partial \alpha}(x)$$

is the running lift coefficient for the rigid missile at unit angle-of-attack. The assumption in Equation 3-9 that the local lift is only dependent on the local angle-of-attack is actually not valid except at Mach numbers nominally greater than 2.5. There is, however, some empirical evidence that the adverse effect of this assumption on missile loads and stability is not great and Equation 3-9 may even be used at subsonic Mach numbers. It is more important that the lift distribution reflect the proper total lift and aerodynamic center for the rigid missile.

The use of Equation 3-9 in dynamic analyses is based on the "quasi-steady" assumption that Equation 3-9 is valid in the case of unsteady flow if α is interpreted as the ratio of induced downwash to the forward velocity.

$$\alpha = \frac{w}{V_\infty} \quad (3-10)$$

The boundary condition of tangent flow gives the following relation for the fluid velocity, or downwash, normal to the free stream:

$$w = V_\infty \frac{\partial p_z}{\partial x} + \frac{\partial p_z}{\partial t} \quad (3-11)$$

The quasi-steady lift is then given by

$$L(x,t) = \frac{1}{2} \rho_\infty V_\infty^2 \frac{\partial C_L}{\partial \alpha}(x) \left(\frac{\partial p_z}{\partial x} + \frac{1}{V_\infty} \frac{\partial p_z}{\partial t} \right) \quad (3-12)$$

A more direct interpretation is that the angle-of-attack is composed of two parts: one, due to the slope, $\frac{\partial p_z}{\partial x}$, of the missile; and, two, due to the shift in the direction of the relative wind caused by the velocity of the missile normal to the free stream, $\frac{\partial p_z}{\partial t}$.

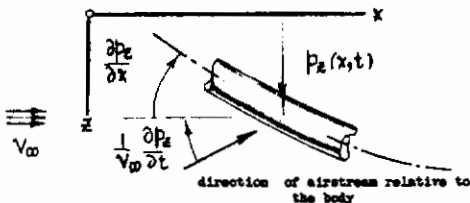

FIGURE 25 LOCAL ANGLE-OF-ATTACK

The virtual work of the aerodynamic forces on the missile is then

$$\delta W = -\frac{1}{2} \rho_\infty V_\infty^2 \int_0^L \delta p_z \frac{\partial C_L}{\partial \alpha}(x) \left(\frac{\partial p_z}{\partial x} + \frac{1}{V_\infty} \frac{\partial p_z}{\partial t} \right) dx \quad (3-13)$$

Contrails

Equation 3-13 can be expressed in terms of the discrete displacements on the body in much the same way as was done for the kinetic and potential energies. From the interpolation formula,

$$p_z(x,t) = \{1 \ \xi \ \xi^2 \ \xi^3\} [\xi]_i [\tau]_i \{p\} \quad (3-14)$$

we have

$$\delta p_z = \{1 \ \xi \ \xi^2 \ \xi^3\} [\xi]_i [\tau]_i \{\delta p\} \quad (3-15)$$

Also, we may interpolate on the angle-of-attack

$$\alpha(x,t) = \{1 \ \xi \ \xi^2 \ \xi^3\} [\xi]_i [\tau]_i \{\alpha\} \quad (3-16)$$

where $\{\alpha\}$ is the matrix of angle-of-attack's at the collocation points. Substitution into Equation 3-13 results in

$$\delta W = -\frac{1}{2} \rho \omega^2 \{\delta p\}' \sum_{i=1}^N [\tau]_i' [\xi]_i \int_{x_{i-1}}^{x_i} \frac{\partial C_L}{\partial \alpha} \begin{bmatrix} 1 & \xi & \xi^2 & \xi^3 \\ \xi & \xi^2 & \xi^3 & \xi^4 \\ \xi^2 & \xi^3 & \xi^4 & \xi^5 \\ \xi^3 & \xi^4 & \xi^5 & \xi^6 \end{bmatrix} dx [\xi]_i [\tau]_i \{\alpha\} \quad (3-17)$$

It is convenient to introduce the matrix of aerodynamic influence coefficients,

$$[\Lambda] = \sum_{i=1}^N [\tau]_i' [\xi]_i \int_{x_{i-1}}^{x_i} \frac{\partial C_L}{\partial \alpha} \begin{bmatrix} 1 & \xi & \xi^2 & \xi^3 \\ \xi & \xi^2 & \xi^3 & \xi^4 \\ \xi^2 & \xi^3 & \xi^4 & \xi^5 \\ \xi^3 & \xi^4 & \xi^5 & \xi^6 \end{bmatrix} dx [\xi]_i [\tau]_i \quad (3-18)$$

We can then write Equation 3-17 as

$$\delta W = -\frac{1}{2} \rho \omega^2 \{\delta p\}' [\Lambda] \{\alpha\} \quad (3-19)$$

Figure 26 shows a typical air load distribution.

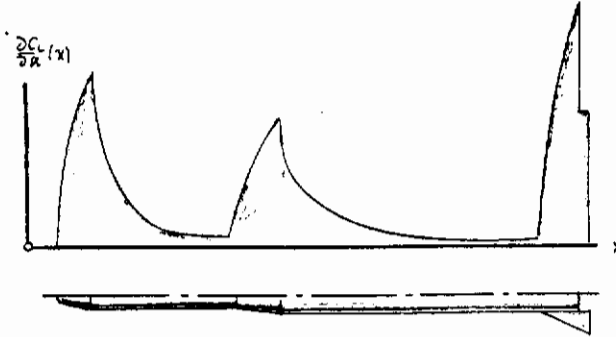

FIGURE 26 RUNNING AIR LOAD DISTRIBUTION FOR A SLENDER LAUNCH VEHICLE

Using the interpolation formula, we can calculate a "differentiation" matrix, $[\Delta]$, with the property

$$\left\{ \frac{\partial p}{\partial x} \right\} \equiv \begin{bmatrix} \frac{\partial p_z}{\partial x}(x_0, t) \\ \frac{\partial p_z}{\partial x}(x_1, t) \\ \vdots \\ \frac{\partial p_z}{\partial x}(x_N, t) \end{bmatrix} = [\Delta] \{p\} \quad (3-20)$$

and the relation

$$\alpha(x, t) = \frac{\partial p_z}{\partial x} + \frac{1}{v_\infty} \frac{\partial p_z}{\partial t} \quad (3-21)$$

can be used to derive

$$\{R\} = [\Delta] \{p\} + \frac{1}{v_\infty} \dot{\{p\}} \quad (3-22)$$

Controls

3.1.1.1.4 Control Forces

We must also include the virtual work done by the moment, Γ , exerted on the control surface by the servo or other means of power control.

$$\delta W = \delta \mathcal{J} \Gamma \quad (3-23)$$

where \mathcal{J} is the control rotation relative to the body. The control rotation is not an independent generalized coordinate, but is related to the p_i by:

$$\mathcal{J} = -\left(\frac{\partial p_i}{\partial x}\right)_{x=x_c} \quad + \quad \left(\frac{\partial p_i}{\partial x}\right)_{x=x_c} \quad (3-24)$$

(on body) (on control surface)

or

$$\mathcal{J} = \{\eta\}' \{p\} \quad (3-25)$$

We then have the virtual work of the servo moment given by

$$\delta W = \{\delta p\}' \{\eta\} \Gamma \quad (3-26)$$

To summarize this section, we have

$$T = \frac{1}{2} \{p\}' [A] \{p\} \quad (3-27)$$

$$U = \frac{1}{2} \{p\}' [K] \{p\} \quad (3-28)$$

$$\delta W = -\frac{1}{2} \rho \alpha \nu_a^2 \{\delta p\}' [A] \{a\} + \{\delta p\}' \{\eta\} \Gamma \quad (3-29)$$

Contrails

where

$$\{\alpha\} = [\Delta] \{p\} + \frac{1}{v_\omega} \dot{\{p\}} \quad (3-30)$$

If we substitute Equation 3-30 into Equation 3-29 and define

$$[L_R] = [\Lambda][\Delta] \quad (3-31)$$

$$[L_I] = [\Lambda] \quad (3-32)$$

we obtain

$$T = \frac{1}{2} \dot{\{p\}}' [A] \{p\} \quad (3-33)$$

$$U = \frac{1}{2} \{p\}' [K] \{p\} \quad (3-34)$$

$$SW = -\frac{1}{2} \rho_\infty v_\infty^2 \{\delta p\}' \left([L_R] \{p\} + \frac{1}{v_\omega} [L_I] \dot{\{p\}} \right) + \{\delta p\}' \{\eta\} r \quad (3-35)$$

$$F = \{\eta\}' \{p\} \quad (3-36)$$

3.1.1.2 Rigid Body Check on the Basic Data

A numerical check can be made on the proper calculation of the matrices in Equations 3-33, 3-34, 3-35, and 3-36. This check is based on comparing the expressions with the corresponding ones for a rigid missile (the check can also be performed for the data associated with the control, but the discussion below will suffice to illustrate the procedure). For the rigid missile with locked control we have

$$T = \frac{1}{2} (M \dot{\theta}^2 + I \dot{\theta}^2) \quad (3-37)$$

$$U = 0 \quad (3-38)$$

$$SW = -\frac{1}{2} \rho_\infty v_\infty^2 \delta \theta \left(C_{L_\alpha} \alpha + C_{L_\theta} \frac{\dot{\theta}}{v_\omega} \right) \quad (3-39)$$

$$-\frac{1}{2} \rho_\infty v_\infty^2 \delta \theta \left(C_{M_\alpha} \alpha + C_{M_\theta} \frac{\dot{\theta}}{v_\omega} \right) \quad (3-40)$$

$$\alpha = -\theta + \frac{1}{v_\omega} \dot{\theta}$$

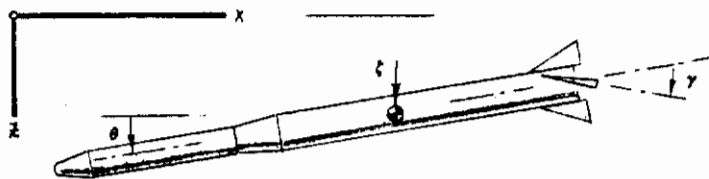

FIGURE 27 GENERALIZED COORDINATES FOR THE RIGID MISSILE

We may also note that for the rigid missile, with locked control,

$$\{p(t)\} = \{1\} J(t) + \{\bar{x}-x\} \theta(t) \quad (3-41)$$

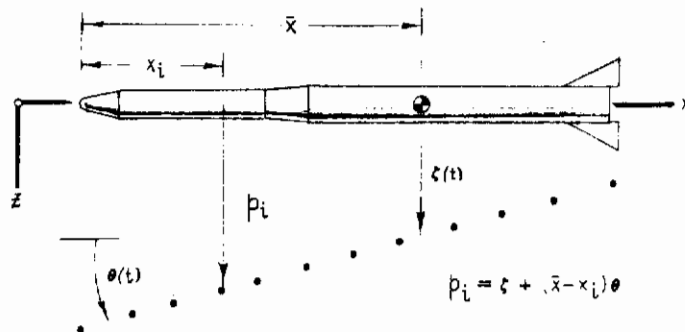

FIGURE 28 COLLOCATION POINT DISPLACEMENTS FOR THE RIGID MISSILE

Substitution of Equation 3-41 into Equations 3-33, 3-34, 3-35, and 3-36 gives

$$T = \frac{1}{2} \{1\}' [A] \{1\} J^2 + 2 \{1\}' [A] \{\bar{x}-x\} \dot{\theta} J + \{\bar{x}-x\}' [A] \{\bar{x}-x\} \dot{\theta}^2 \quad (3-42)$$

$$U = \frac{1}{2} \{1\}' [K] \{1\} J^2 + 2 \{1\}' [K] \{\bar{x}-x\} J \theta + \{\bar{x}-x\}' [K] \{\bar{x}-x\} \theta^2 \quad (3-43)$$

Contrails

$$\begin{aligned}
 \delta W = & -\frac{1}{2} \rho_{\infty} V_{\infty}^2 \left(\delta J \{1\}' [L_R] \{1\} J + \delta J \{1\}' [L_R] \{1\} \delta \theta \right. & (3-44) \\
 & + \delta \theta \{\bar{x}-x\}' [L_R] \{1\} J + \delta \theta \{\bar{x}-x\}' [L_R] \{1\} \delta \theta \\
 & + \delta J \{1\}' [L_I] \{1\} \frac{\dot{J}}{V_{\infty}} + \delta J \{1\}' [L_I] \{1\} \delta \theta \frac{\dot{\theta}}{V_{\infty}} \\
 & \left. + \delta \theta \{\bar{x}-x\}' [L_I] \{1\} \frac{\dot{J}}{V_{\infty}} + \delta \theta \{\bar{x}-x\}' [L_I] \{1\} \delta \theta \frac{\dot{\theta}}{V_{\infty}} \right)
 \end{aligned}$$

By comparing Equation 3-37 with Equation 3-42, we must conclude that

$$M = \{1\}' [A] \{1\} \quad (3-45)$$

$$I = \{\bar{x}-x\}' [A] \{\bar{x}-x\} \quad (3-46)$$

also

$$\{\bar{x}-x\}' [A] \{1\} = \{0\} \quad (3-47)$$

gives

$$\bar{x} = \frac{\{x\}' [A] \{1\}}{\{1\}' [A] \{1\}} \quad (3-48)$$

Equations 3-45, 3-46, and 3-48 are independent checks on the proper calculation of the mass matrix.

By comparing Equation 3-43 with Equation 3-38, we conclude that

$$[K] \{1\} = \{0\} \quad (3-49)$$

$$[K] \{\bar{x}-x\} = \{0\} \quad (3-50)$$

We also have the following relations

$$[L_R] \{\bar{x}-x\} = -[L_I] \{1\} \quad (3-51)$$

$$[L_R] \{1\} = \{0\} \quad (3-52)$$

Contrails

which is true because of properties of the differentiation matrix like:

$$[\Delta] \{x\} = \{1\} \quad (3-53)$$

and

$$[\Delta] \{1\} = \{0\} \quad (3-54)$$

Equation 3-44 then becomes

$$\begin{aligned} \delta W = & -\frac{1}{2} \rho a V_0^2 \left(\delta J \{1\}' [L_I] \{1\} \left(\frac{\dot{J}}{V_0} - \theta \right) + \delta J \{1\}' [L_I] \{ \bar{x} - x \} \frac{\dot{\theta}}{V_0} \right. \\ & \left. + \delta \theta \{ \bar{x} - x \}' [L_I] \{1\} \left(\frac{\dot{J}}{V_0} - \theta \right) + \delta \theta \{ \bar{x} - x \}' [L_I] \{ \bar{x} - x \} \frac{\dot{\theta}}{V_0} \right) \end{aligned} \quad (3-55)$$

By comparison with Equations 3-39 and 3-40 we must conclude that

$$C_{L_R} = \{1\}' [L_I] \{1\} = -\{1\}' [L_R] \{ \bar{x} - x \} \quad (3-56)$$

$$C_{M_R} = \{ \bar{x} - x \}' [L_I] \{1\} = -\{ \bar{x} - x \}' [L_R] \{ \bar{x} - x \} \quad (3-57)$$

$$C_{L_{\dot{\theta}}} = \{1\}' [L_I] \{ \bar{x} - x \} \quad (3-58)$$

$$C_{M_{\dot{\theta}}} = \{ \bar{x} - x \}' [L_I] \{ \bar{x} - x \} \quad (3-59)$$

which are several independent checks on the proper calculation of the aerodynamic matrices.

Under circumstances in which the aerodynamic forces can be expressed completely by:

Contrails

$$\delta W = -\frac{1}{2} \rho_0 v_0^2 \{ \delta p \}' [\Lambda] \{ \alpha \} \quad (3-60)$$

$$\{ \alpha \} = [\Delta] H \{ \beta \} + \frac{1}{v_0} \{ \dot{\beta} \} \quad (3-61)$$

we have

$$C_{L\alpha} = \{ 1 \}' [\Lambda] H \{ 1 \} \quad (3-62)$$

$$C_{M\alpha} = \{ \bar{x} - x \}' [\Lambda] H \{ 1 \} \quad (3-63)$$

$$C_{L\dot{\alpha}} = \{ 1 \}' [\Lambda] \{ \bar{x} - x \} \quad (3-64)$$

$$C_{M\dot{\alpha}} = \{ \bar{x} - x \}' [\Lambda] H \{ \bar{x} - x \} \quad (3-65)$$

as checks on the aerodynamic influence coefficients with the following checks on the differentiation matrix

$$[\Delta] H \{ \bar{x} - x \} = -\{ 1 \} \quad (3-66)$$

$$[\Delta] H \{ 1 \} = \{ 0 \} \quad (3-67)$$

All of the properties in Equations 3-45 through 3-48 and 3-56 through 3-59 may be calculated from the original expressions for the continuous missile. For example, the total mass is

$$M = \int_0^L m(x) dx \quad (3-68)$$

the total moment of inertia is

$$I = \int_0^L (\bar{x} - x)^2 m(x) dx \quad (3-69)$$

and the total rigid body moment coefficient is

$$C_{M_R} = \int_0^L (\bar{x}-x) \frac{\partial C_L}{\partial x}(x) dx \quad (3-70)$$

In a similar manner the damping derivatives are

$$C_{L\dot{\theta}} = \int_0^L (\bar{x}-x) \frac{\partial C_L}{\partial \dot{x}}(x) dx \quad (3-71)$$

$$C_{M\dot{\theta}} = \int_0^L (\bar{x}-x)^2 \frac{\partial C_L}{\partial \dot{x}}(x) dx \quad (3-72)$$

Lastly,

$$\bar{x} = \frac{\int_0^L x m(x) dx}{\int_0^L m(x) dx} \quad (3-73)$$

may be checked by comparison with Equation 3-48.

3.1.2 The Equations for Determining "Loads" and Transient Motion

3.1.2.1 The Equations for Calculating Transient Internal Loads

The equations relating internal stresses to the generalized coordinates, velocities, and accelerations are derived by applying Lagrange's equations to the expressions for the kinetic and potential energy. Using Equations 3-33, 3-34 and 3-35 in Lagrange's equations (Equation 2-64), we obtain

$$\begin{aligned} [A]\ddot{p}\} + [K]p\} \\ = -\frac{1}{2}\rho\omega^2 \left([L_R]p\} + \frac{1}{V_0} [L_I]\dot{p}\} \right) + \{q\} \quad (3-74) \end{aligned}$$

We may arrange this equation as

$$[K]p\} = -[A]\ddot{p}\} - \frac{1}{2}\rho\omega^2 \left([L_R]p\} + \frac{1}{V_0} [L_I]\dot{p}\} \right) + \{q\} \quad (3-75)$$

These are the "loads" equations for the missile; the left-hand side is the "effective" loads which are directly related to the internal stresses of the structure¹. If we introduce the definition

$$\{F\} = [K]\{p\} \quad (3-76)$$

then we can derive a matrix which relates the shears and bending moments along the missile to the "effective" loads, $\{F\}$. The shears and bending moments just to the right of the collocation points are

$$V_i = \sum_{j \leq i}^N F_j \quad ; \quad M_i = \sum_{j \leq i}^N (x_i - x_j) F_j \quad (3-77)$$

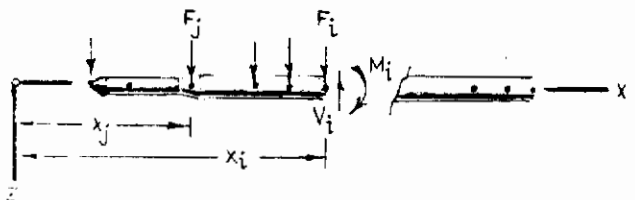

FIGURE 29 INTERNAL LOADS AT THE COLLOCATION POINTS

Equations 3-77 can be written as

$$\begin{bmatrix} V_0 \\ V_1 \\ \vdots \\ V_N \\ M_0 \\ M_1 \\ \vdots \\ M_N \end{bmatrix} = \begin{bmatrix} \vdots & 0 & 0 & \dots & 0 \\ \vdots & \vdots & 0 & \dots & 0 \\ \vdots & \vdots & \vdots & \dots & \vdots \\ \vdots & \vdots & \vdots & \dots & \vdots \\ \vdots & \vdots & \vdots & \dots & \vdots \\ x_0 - x_0 & 0 & 0 & \dots & 0 \\ x_1 - x_0 & x_1 - x_1 & 0 & \dots & 0 \\ \vdots & \vdots & \vdots & \dots & \vdots \\ x_N - x_0 & \dots & \dots & \dots & x_N - x_N \end{bmatrix} \begin{bmatrix} F_0 \\ F_1 \\ \vdots \\ F_N \end{bmatrix} \quad (3-78)$$

¹If internal damping is included, and described by the Rayleigh dissipation function, then the internal stresses are related to

$$\{F\} = [K]\{p\} + [B]\{\dot{p}\} \quad \text{see also Paragraph 5.1.1.1, Equation 5-54}$$

or simply as

$$\begin{bmatrix} \{V\} \\ \{M\} \end{bmatrix} = [R]\{F\} \quad (3-79)$$

If the time histories of the generalized coordinates are known, then either side of Equation 3-75 may be used in Equation 3-79 to compute the internal loads. When the modal approximation is made, however, the right-hand side gives better results. This is the so-called "modal-acceleration" method.¹ Substituting Equation 3-75 into Equation 3-79, we obtain

$$\begin{bmatrix} \{V\} \\ \{M\} \end{bmatrix} = -[R][A]\{\ddot{p}\} - \frac{1}{2}\rho v^2 [R]([L_R]\{\dot{p}\} + \frac{1}{v_\infty}[L_I]\{\dot{p}\}) + [R]\{\eta\}r \quad (3-80)$$

In addition to the inertia loads and aerodynamic loads, there are generally external loads forcing the system and these forces must be included as additional terms in Equation 3-80. Additional forces are considered in Paragraph 3.1.2.6.

It is conceivable that Equation 3-74 could be integrated to obtain the time histories of the quantities which appear in Equation 3-80. This is not usually done, however, because it is expedient to reduce the number of degrees-of-freedom of the problem by transforming to "modal" generalized coordinates. This is the subject of the next section.

3.1.2.2 The Modal Equations of Motion

The vibration modes of the missile are obtained from Equation 3-74 with no external forces and the control surface locked in the position, $\gamma = 0$.

$$[A]\{\ddot{p}\} + [K]\{p\} = \{0\} \quad (3-81)$$

The solution of these equations is important for deriving a transformation which simplifies the solution of the differential equations governing the motion of the system (see Paragraph 2.2.3.1). If we assume a separated solution to these equations,

$$\{p(t)\} = \{\varphi\} q(t) \quad (3-82)$$

¹See, for example, Bisplinghoff, Ashley, and Halfman Aeroelasticity pp. 642.

Contrails

we obtain

$$(-\omega^2[A] + [K])\{\varphi\} = \{0\} \quad (3-83)$$

In the case of an unrestrained missile we have two zero-frequency modes (see Paragraph 2.2.3.4);

$$\{\varphi_R\}_1 = \{1\}; \quad \{\varphi_R\}_2 = \{\bar{x} - x\} \quad (3-84)$$

which represent a rigid-body displacement and rotation about the center of mass. From Equation 3-83, we have

$$[K]\{1\} = \{0\} \quad (3-85)$$

$$[K]\{\bar{x} - x\} = \{0\} \quad (3-86)$$

The non-zero frequency modes are calculated from

$$[\Gamma][E][\Gamma][A]\{\varphi\} = \lambda\{\varphi\} \quad (3-87)$$

as discussed in Paragraph 2.2.3.4. In the present case, we have

$$[\Gamma] = [I] - [A] \left(\frac{1}{M} \{1\}\{1\}' + \frac{1}{I} \{\bar{x} - x\}\{\bar{x} - x\}' \right) \quad (3-88)$$

(also, the influence coefficients are derived with the control locked, $\gamma = 0$). The solutions to Equations 3-83 are used to form the following transformation of coordinates

$$\begin{aligned} \{p(t)\} &= \{1\}\delta(t) + \{\bar{x} - x\}\theta(t) + \sum_{i=1}^M \{\varphi_i\} q_i(t) + \{\varphi_0\}\gamma \\ &= \begin{bmatrix} \{1\}, \{\bar{x} - x\}, \{\varphi_1\}, \dots, \{\varphi_{M+1}\}, \{\varphi_0\} \end{bmatrix} \begin{bmatrix} \delta \\ \theta \\ q_1 \\ q_2 \\ \vdots \\ q_M \\ \gamma \end{bmatrix} \end{aligned} \quad (3-89)$$

Contrails

Where $\{\phi_j\}$ are the values of the generalized coordinates for a unit rotation of the rigid control relative to the rigid body.

An interpretation of the significance of the zero-frequency modal coordinates, ζ and θ , is given by premultiplying Equation 3-89 by $\{1\}'[A]$ and $\{\bar{x}-x\}'[A]$ and making use of the orthogonality conditions for the modal columns (see Equation 2-210, Paragraph 2.2.3.4).

$$\{1\}'[A]\{\dot{p}\} = \{1\}'[A]\{\dot{1}\}\zeta + \{1\}'[A]\{\bar{x}-x\}\dot{\theta} \quad (3-90)$$

$$\{\bar{x}-x\}'[A]\{\dot{p}\} = \{\bar{x}-x\}'[A]\{\dot{1}\}\zeta + \{\bar{x}-x\}'[A]\{\bar{x}-x\}\dot{\theta} \quad (3-91)$$

Making use of Equations 3-45, 3-46, and 3-47 we have

$$\zeta(t) = \frac{1}{M} \{1\}'[A]\{\dot{p}\} \quad (3-92)$$

$$\dot{\theta}(t) = \frac{1}{I} \{\bar{x}-x\}'[A]\{\dot{p}\} \quad (3-93)$$

In the first of these equations ζ can be interpreted as the lateral displacement of the instantaneous center of mass of the missile. The analogous relation for the "continuous" description of the missile is

$$\zeta(t) = \frac{1}{M} \int_0^L m(x) p_z(x,t) dx. \quad (3-94)$$

A corresponding interpretation of θ is not so direct, nevertheless we have the relation,

$$\dot{\theta}(t) = \frac{1}{I} \int_0^L (\bar{x}-x) m(x) \dot{p}_z(x,t) dx, \quad (3-95)$$

in analogy to Equation 3-93. We can write Equation 3-89 as

$$\{\dot{p}\} = [q] \{H_0\} \quad (3-96)$$

Contrails

where

$$[q] = [f(t), f(\dot{x}-x), f(\phi), f(\psi)_1, f(\psi)_2, \dots, f(\psi)_M, f(\psi)_N] \quad (3-97)$$

and

$$\{q\} = \begin{bmatrix} \dot{x} \\ \phi \\ \psi_1 \\ \psi_2 \\ \vdots \\ \psi_M \\ \psi_N \end{bmatrix} \quad (3-98)$$

The modal transformation matrix, $[\phi]$, is not generally square because the high frequency modes are omitted on the basis that they have little effect on the dynamics of the system. Generally the number of degrees-of-freedom in Equation 3-96 can be reduced in this way without compromising the description of the dynamics of the missile. This constraint is not serious in most response problems; however, due to this approximation, Equation 3-75 can never be satisfied exactly. This results in the difference in accuracy between the "modal-displacement" and "modal-acceleration" method of loads analysis.

To transform to modal coordinates we substitute Equation 3-96 into Equations 3-33, 3-34, and 3-35 which gives

$$T = \frac{1}{2} \{\dot{q}\}' [M] \{\dot{q}\} \quad (3-99)$$

$$U = \frac{1}{2} \{q\}' [F] \{q\} \quad (3-100)$$

$$\delta W = -\frac{1}{2} \rho \omega^2 \{ \delta q \}' \left([C_R] \{q\} + \frac{1}{v_\omega} [C_I] \{\dot{q}\} \right) + \{ \delta q \}' [\varphi]' \{ \eta \} \quad (3-101)$$

where

$$[M] = [\varphi]' [A] [\varphi] \quad (3-102)$$

$$[F] = [\varphi]' [K] [\varphi] \quad (3-103)$$

Contrails

$$[C_R] = [\varphi]' [L_R] [\varphi] \quad (3-104)$$

$$[C_I] = [\varphi]' [L_I] [\varphi] \quad (3-105)$$

The final form of Equations 3-99, 3-100, and 3-101 is quite general, being independent of many of the simplifying assumptions that were made in the derivation. It is often important to account for flexibility of the control surface, particularly when investigating problems of "control effectiveness." It can be shown that Equation 3-35 is the same, in this case, although the coefficients are different. Also, steady-state aerodynamic interference between control surface and body can be accounted for "exactly" in the case of a flexible control surface by including a full matrix of aerodynamic influence coefficients.

The equations of motion are obtained by using relations 3-99, 3-100, and 3-101 in Lagrange's equations (Equation 2-64, Paragraph 2.1.2.1) regarding ζ , θ , γ , and the q_i 's as independent generalized coordinates. The result is

$$[M] \ddot{q} + [F] \dot{q} + \frac{1}{2} \rho v \omega^2 ([C_R] \dot{q} + \frac{1}{v \omega} [C_I] \dot{q}) = [q]' \{ \eta \} \Gamma \quad (3-106)$$

The solution to the above differential equations can be used in Equation 3-80 to obtain the transient shears and bending moments¹. If ζ , θ , γ , and the q_i 's have been obtained as functions of time, then the collocation point coordinates are obtained from:

$$\{ p \} = [\varphi] \{ q(t) \} \quad (3-107)$$

Substituting this into Equation 3-80, we obtain the final form of the transient loads equations

$$\begin{bmatrix} \{ V \} \\ \{ M \} \end{bmatrix} = - [R] [A] [\varphi] \ddot{q} - \frac{1}{2} \rho v \omega^2 [R] [L_R] [\varphi] \dot{q} - \frac{1}{2} \rho v \omega [R] [L_I] [\varphi] \dot{q} + [R] \{ \eta \} \Gamma$$

(3-108)

¹Transient loads problems such as response to gusts and impulsive control motions can be handled effectively by a computer program which solves a general set of equations similar to Equations 3-106. The second part of Appendix VI describes such a set of equations and a method for their solution.

3.1.2.3 The "Quasi-Rigid" Approximation and Aeroelastic Corrections to the Rigid-Body Stability Derivatives

It is sometimes undesirable to have to solve the differential equations, 3-106, in order to obtain transient loads. This is particularly true in view of the fact that an approximate solution of Equations 3-106 can be used to obtain preliminary loads for structural design purposes.

For the purpose of obtaining an approximate solution to Equations 3-106, we partition the equations into a rigid body part and an elastic part.

To simplify the discussion we will, in this section, redefine $\{\phi\}$, and $\{q\}$ so that they are the elastic modes and coordinates only. We then have

$$\{p\} = \{1\}\dot{\gamma} + \{\bar{x}-x\}\dot{\theta} + [\varphi]\{\dot{z}\} + \{\varphi_p\}\dot{\gamma} \quad (3-109)$$

for Equation 3-89. By expanding the products in Equations 3-102, 3-103, 3-104 and 3-105, it can be shown that

$$[M] = \begin{bmatrix} \{1\}'[A]H\{1\} & \{1\}'[A]H\{\bar{x}-x\} & \{1\}'[A][\varphi] & \{1\}'[A]\{\varphi_p\} \\ \{\bar{x}-x\}'[A]H\{1\} & \{\bar{x}-x\}'[A]H\{\bar{x}-x\} & \{\bar{x}-x\}'[A][\varphi] & \{\bar{x}-x\}'[A]H\{\varphi_p\} \\ [\varphi]'[A]H\{1\} & [\varphi]'[A]H\{\bar{x}-x\} & [\varphi]'[A][\varphi] & [\varphi]'[A]H\{\varphi_p\} \\ \{\varphi_p\}'[A]H\{1\} & \{\varphi_p\}'[A]H\{\bar{x}-x\} & \{\varphi_p\}'[A][\varphi] & \{\varphi_p\}'[A]H\{\varphi_p\} \end{bmatrix} \quad (3-110)$$

$$[F] = \begin{bmatrix} \{1\}'[K]H\{1\} & \{1\}'[K]H\{\bar{x}-x\} & \{1\}'[K][\varphi] & \{1\}'[K]H\{\varphi_p\} \\ \{\bar{x}-x\}'[K]H\{1\} & \{\bar{x}-x\}'[K]H\{\bar{x}-x\} & \{\bar{x}-x\}'[K][\varphi] & \{\bar{x}-x\}'[K]H\{\varphi_p\} \\ [\varphi]'[K]H\{1\} & [\varphi]'[K]H\{\bar{x}-x\} & [\varphi]'[K][\varphi] & [\varphi]'[K]H\{\varphi_p\} \\ \{\varphi_p\}'[K]H\{1\} & \{\varphi_p\}'[K]H\{\bar{x}-x\} & \{\varphi_p\}'[K][\varphi] & \{\varphi_p\}'[K]H\{\varphi_p\} \end{bmatrix} \quad (3-111)$$

Contrails

$$[C_R] = \begin{bmatrix} \{1\}'[L_R H 1] & \{1\}'[L_R H \bar{x}-x] & \{1\}'[L_R](\varphi) & \{1\}'[L_R]H\varphi_p\} \\ \{\bar{x}-x\}'[L_R H 1] & \{\bar{x}-x\}'[L_R H \bar{x}-x] & \{\bar{x}-x\}'[L_R](\varphi) & \{\bar{x}-x\}'[L_R]H\varphi_p\} \\ [\varphi]'[L_R H 1] & [\varphi]'[L_R H \bar{x}-x] & [\varphi]'[L_R](\varphi) & [\varphi]'[L_R]H\varphi_p\} \\ \{\varphi_p\}'[L_R H 1] & \{\varphi_p\}'[L_R H \bar{x}-x] & \{\varphi_p\}'[L_R](\varphi) & \{\varphi_p\}'[L_R]H\varphi_p\} \end{bmatrix} \quad (3-112)$$

$$[C_I] = \begin{bmatrix} \{1\}'[L_I H 1] & \{1\}'[L_I H \bar{x}-x] & \{1\}'[L_I](\varphi) & \{1\}'[L_I]H\varphi_p\} \\ \{\bar{x}-x\}'[L_I H 1] & \{\bar{x}-x\}'[L_I H \bar{x}-x] & \{\bar{x}-x\}'[L_I](\varphi) & \{\bar{x}-x\}'[L_I]H\varphi_p\} \\ [\varphi]'[L_I H 1] & [\varphi]'[L_I H \bar{x}-x] & [\varphi]'[L_I](\varphi) & [\varphi]'[L_I]H\varphi_p\} \\ \{\varphi_p\}'[L_I H 1] & \{\varphi_p\}'[L_I H \bar{x}-x] & \{\varphi_p\}'[L_I](\varphi) & \{\varphi_p\}'[L_I]H\varphi_p\} \end{bmatrix} \quad (3-113)$$

Using Equations 3-45 through 3-48 and the orthogonality relations (Equation 2-169, 2-170 and 2-210 of Paragraph 2.2.3), we can write these more simply as

$$[M] = \begin{bmatrix} M & 0 & \{0\}' & 0 \\ 0 & I & \{0\}' & 0 \\ \{0\} & \{0\} & [A] & [\varphi]'[A]H\varphi_p\} \\ 0 & 0 & \{\varphi_p\}'[A] & J \end{bmatrix} \quad (3-114)$$

where

$$\begin{aligned} M &= \{1\}'[A]H1\} \\ I &= \{\bar{x}-x\}'[A]H\bar{x}-x\} \\ J &= \{\varphi_p\}'[A]H\varphi_p\} \end{aligned}$$

Controls

(We have assumed that the control mode is orthogonal to the rigid body modes.
For further discussion see Paragraph 3.1.3.5, Equations 3-508 and 3-509).

$$[F] = \begin{bmatrix} 0 & 0 & \{0\}' & 0 \\ 0 & 0 & \{0\}' & 0 \\ \{0\} & \{0\} & \{k_{\lambda}\} & \{0\} \\ 0 & 0 & \{0\}' & 0 \end{bmatrix} \quad (3-115)$$

$$[C_R] = \begin{bmatrix} 0 & -C_{L\alpha} & \{1\}'[L_R][\varphi] & C_{L\beta} \\ 0 & -C_{M\alpha} & \{\bar{x}-x\}'[L_R][\varphi] & C_{M\beta} \\ \{0\}' & -[\varphi]'[L_I]H\{1\} & [\varphi]'[L_R][\varphi] & [\varphi]'[L_R]H\{\varphi_{\beta}\}' \\ 0 & -C_{H\alpha} & \{\varphi_{\beta}\}'[L_R][\varphi] & C_{H\beta} \end{bmatrix} \quad (3-116)$$

$$[C_I] = \begin{bmatrix} C_{L\alpha} & C_{L\theta} & \{1\}'[L_I][\varphi] & C_{L\beta} \\ C_{M\alpha} & C_{M\theta} & \{\bar{x}-x\}'[L_I][\varphi] & C_{M\beta} \\ [\varphi]'[L_I]H\{1\}' & [\varphi]'[L_I]H\{\bar{x}-x\}' & [\varphi]'[L_I][\varphi] & [\varphi]'[L_I]H\{\varphi_{\beta}\}' \\ C_{H\alpha} & C_{H\theta} & \{\varphi_{\beta}\}'[L_I][\varphi] & C_{H\beta} \end{bmatrix} \quad (3-117)$$

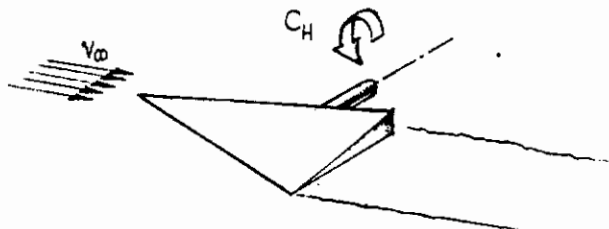

FIGURE 30 SIGN CONVENTION FOR CONTROL "HINGE" MOMENTS

We may now use these results to rewrite Equations 3-106 as:

$$M\ddot{\theta} + \frac{1}{2}\rho V_\infty^2 \left(C_{L\alpha} \left(\frac{\dot{\theta}}{V_\infty} - \theta \right) + C_{L\dot{\theta}} \frac{\dot{\theta}}{V_\infty} + C_{L\dot{\gamma}} \dot{\gamma} + C_{L\ddot{\gamma}} \frac{\ddot{\gamma}}{V_\infty} \right) + \frac{1}{2}\rho V_\infty^2 \left(\dot{\gamma} \dot{\theta} [L_R][\varphi] \dot{q} + \frac{1}{V_\infty} \dot{\gamma} \dot{\theta} [L_I][\varphi] \dot{q} \right) = 0 \quad (3-118)$$

$$I\ddot{\theta} + \frac{1}{2}\rho V_\infty^2 \left(C_{M\alpha} \left(\frac{\dot{\theta}}{V_\infty} - \theta \right) + C_{M\dot{\theta}} \frac{\dot{\theta}}{V_\infty} + C_{M\dot{\gamma}} \dot{\gamma} + C_{M\ddot{\gamma}} \frac{\ddot{\gamma}}{V_\infty} \right) + \frac{1}{2}\rho V_\infty^2 \left(\dot{\gamma} \dot{\theta} [L_R][\varphi] \dot{q} + \frac{1}{V_\infty} \dot{\gamma} \dot{\theta} [L_I][\varphi] \dot{q} \right) = 0 \quad (3-119)$$

$$\dot{q} \ddot{\theta} + \Gamma \frac{1}{\lambda} \dot{q} \dot{\theta} + \frac{1}{2}\rho V_\infty^2 \left([\varphi]' [L_I] \dot{\gamma} \dot{\theta} \left(\frac{\dot{\theta}}{V_\infty} - \theta \right) + [\varphi]' [L_I] \dot{\gamma} \dot{\theta} \frac{\dot{\theta}}{V_\infty} \right) + \frac{1}{2}\rho V_\infty^2 \left([\varphi]' [L_R][\varphi] \dot{q} \dot{\theta} + \frac{1}{V_\infty} [\varphi]' [L_I][\varphi] \dot{q} \dot{\theta} \right) + [\varphi]' [A] \dot{q} \dot{\theta} \ddot{\gamma} + \frac{1}{2}\rho V_\infty^2 \left([\varphi]' [L_R][\varphi] \dot{q} \dot{\theta} \dot{\gamma} + [\varphi]' [L_I][\varphi] \dot{q} \dot{\theta} \frac{\ddot{\gamma}}{V_\infty} \right) \quad (3-120)$$

$$J\ddot{\gamma} + \dot{\varphi} \dot{\gamma}' [A][\varphi] \dot{q} \ddot{\theta} + \frac{1}{2}\rho V_\infty^2 \left(C_{H\alpha} \left(\frac{\dot{\theta}}{V_\infty} - \theta \right) + C_{H\dot{\theta}} \frac{\dot{\theta}}{V_\infty} + C_{H\dot{\gamma}} \dot{\gamma} + C_{H\ddot{\gamma}} \frac{\ddot{\gamma}}{V_\infty} \right) + \frac{1}{2}\rho V_\infty^2 \left(\dot{\varphi} \dot{\gamma}' [L_R][\varphi] \dot{q} \dot{\theta} + \frac{1}{V_\infty} \dot{\varphi} \dot{\gamma}' [L_I][\varphi] \dot{q} \dot{\theta} \right) = \Gamma \quad (3-121)$$

where we have used the fact that

$$\{\eta\}'\{1\} = 0 \quad (3-122)$$

$$\{\eta\}'\{\bar{x}-x\} = 0 \quad (3-123)$$

$$\{\eta\}'\{\varphi_r\} = 1 \quad (3-124)$$

$$\{\eta\}'\{\varphi\} = \{0\} \quad (3-125)$$

Up to this point we have done little more than change the form of Equations 3-106; the above equations are still a set of linear, second order, differential equations. On the basis that we are interested only in response to "slowly" varying forces, we make the approximation

$$\{\dot{q}\} = \{\ddot{q}\} = \{0\} \quad (3-126)$$

which we shall call the "quasi-rigid" approximation. In addition, we will assume that

$$\ddot{r} = \dot{r} = 0 \quad (3-127)$$

Equations 3-118 through 3-121 can then be replaced by

$$M\ddot{J} + \frac{1}{2}\rho_0 V_0^2 \left(C_{L_R} \left(\frac{\dot{J}}{V_0} - \theta \right) + C_{L_\theta} \frac{\dot{\theta}}{V_0} + C_{L_J} J \right) + \frac{1}{2}\rho_0 V_0^2 \{1\}' [L_R] [\varphi] \{q\} = 0 \quad (3-128)$$

$$I\ddot{\theta} + \frac{1}{2}\rho_0 V_0^2 \left(C_{M_R} \left(\frac{\dot{\theta}}{V_0} - \theta \right) + C_{M_\theta} \frac{\dot{\theta}}{V_0} + C_{M_J} J \right) + \frac{1}{2}\rho_0 V_0^2 \{\bar{x}-x\}' [L_R] [\varphi] \{q\} = 0 \quad (3-129)$$

Contrails

$$\begin{aligned}
 & \left(\frac{2}{\rho \omega v_0^2} \Gamma'_{\lambda_j} + [\varphi]' [L_R] [\varphi] \right) \{q_j\} & (3-130) \\
 & = - [\varphi]' [L_I] H \{ \dot{\lambda}_j - \theta \} - [\varphi]' [L_I] H \bar{x} - x \} \frac{\dot{\theta}}{v_0} \\
 & \quad - [\varphi]' [L_R] H \varphi_j \gamma
 \end{aligned}$$

$$\frac{1}{2} \rho \omega v_0^2 \left(C_{H\lambda} \left(\frac{\dot{\lambda}_j}{v_0} - \theta \right) + C_{H\dot{\theta}} \frac{\dot{\theta}}{v_0} + C_{H\gamma} \gamma + \{q_j\}' [L_R] [\varphi] H \{q_j\} \right) = \Gamma \quad (3-131)$$

When the quasi-rigid approximation is made, the modal equations are no longer differential equations and may be solved algebraically for the q's.

$$\begin{aligned}
 \{q_j\} & = - \left(\frac{2}{\rho \omega v_0^2} \Gamma'_{\lambda_j} + [\varphi]' [L_R] [\varphi] \right)^{-1} [\varphi]' [L_I] H \{ \dot{\lambda}_j - \theta \} & (3-132) \\
 & - \left(\frac{2}{\rho \omega v_0^2} \Gamma'_{\lambda_j} + [\varphi]' [L_R] [\varphi] \right)^{-1} [\varphi]' [L_I] H \bar{x} - x \} \frac{\dot{\theta}}{v_0} \\
 & - \left(\frac{2}{\rho \omega v_0^2} \Gamma'_{\lambda_j} + [\varphi]' [L_R] [\varphi] \right)^{-1} [\varphi]' [L_R] H \varphi_j \gamma
 \end{aligned}$$

Equation 3-132 can be used to eliminate the q's from the rigid-body equations

$$\begin{aligned}
 & M \ddot{\lambda}_j + \frac{1}{2} \rho \omega v_0^2 \left(C_{L\lambda} \left(\frac{\dot{\lambda}_j}{v_0} - \theta \right) + C_{L\dot{\theta}} \frac{\dot{\theta}}{v_0} + C_{L\gamma} \gamma \right) & (3-133) \\
 & - \frac{1}{2} \rho \omega v_0^2 \{q_j\}' [L_R] [\varphi] \left(\frac{2}{\rho \omega v_0^2} \Gamma'_{\lambda_j} + [\varphi]' [L_R] [\varphi] \right)^{-1} \left([\varphi]' [L_I] H \{ \dot{\lambda}_j - \theta \} + [L_I] H \bar{x} - x \} \frac{\dot{\theta}}{v_0} \right. \\
 & \quad \left. + [L_R] H \varphi_j \gamma \right) = 0
 \end{aligned}$$

Contrails

$$\begin{aligned}
 & I\ddot{\theta} + \frac{1}{2}\rho_0 V_0^2 \left(C_{M\alpha} \left(\frac{\dot{\theta}}{V_0} - \theta \right) + C_{M\dot{\theta}} \frac{\dot{\theta}}{V_0} + C_{M\gamma} \gamma \right) \\
 & - \frac{1}{2}\rho_0 V_0^2 \{ \bar{x} - x \} \{ [L_R][\varphi] \left(\frac{2}{\rho_0 V_0^2} \Gamma \lambda_J + [\varphi]' [L_R][\varphi] \right)^{-1} [\varphi]' \left([L_I][\dot{\theta}] \left(\frac{\dot{\theta}}{V_0} - \theta \right) \right. \\
 & \qquad \qquad \qquad \left. + [L_I][\bar{x} - x] \frac{\dot{\theta}}{V_0} \right. \\
 & \qquad \qquad \qquad \left. + [L_R][\varphi] \gamma \right) \\
 & = 0
 \end{aligned} \tag{3-134}$$

$$\begin{aligned}
 & \frac{1}{2}\rho_0 V_0^2 \left(C_{H\alpha} \left(\frac{\dot{\theta}}{V_0} - \theta \right) + C_{H\dot{\theta}} \frac{\dot{\theta}}{V_0} + C_{H\gamma} \gamma \right) \\
 & - \frac{1}{2}\rho_0 V_0^2 \{ \varphi_0 \} \{ [L_R][\varphi] \left(\frac{2}{\rho_0 V_0^2} \Gamma \lambda_J + [\varphi]' [L_R][\varphi] \right)^{-1} [\varphi]' \left([L_R][\varphi_0] \gamma + [L_I][\dot{\theta}] \left(\frac{\dot{\theta}}{V_0} - \theta \right) + [L_I][\bar{x} - x] \frac{\dot{\theta}}{V_0} \right) = \Gamma
 \end{aligned} \tag{3-135}$$

If we introduce the notion of "flexible aerodynamic coefficients," we can write Equations 3-133 and 3-134 as

$$M\ddot{J} + \frac{1}{2}\rho_0 V_0^2 \left(C_{L\alpha}^F \left(\frac{\dot{\theta}}{V_0} - \theta \right) + C_{L\dot{\theta}}^F \frac{\dot{\theta}}{V_0} + C_{L\gamma}^F \gamma \right) = 0 \tag{3-136}$$

$$I\ddot{\theta} + \frac{1}{2}\rho_0 V_0^2 \left(C_{M\alpha}^F \left(\frac{\dot{\theta}}{V_0} - \theta \right) + C_{M\dot{\theta}}^F \frac{\dot{\theta}}{V_0} + C_{M\gamma}^F \gamma \right) = 0 \tag{3-137}$$

$$\frac{1}{2}\rho_0 V_0^2 \left(C_{H\alpha}^F \left(\frac{\dot{\theta}}{V_0} - \theta \right) + C_{H\dot{\theta}}^F \frac{\dot{\theta}}{V_0} + C_{H\gamma}^F \gamma \right) = \Gamma \tag{3-138}$$

where, the flexible coefficients are given by

$$C_{L\alpha}^F = C_{L\alpha} - \{ \dot{\theta} \} \{ [L_R][\varphi] \left(\frac{2}{\rho_0 V_0^2} \Gamma \lambda_J + [\varphi]' [L_R][\varphi] \right)^{-1} [\varphi]' [L_I][\dot{\theta}] \} \tag{3-139}$$

$$C_{M\alpha}^F = C_{M\alpha} - \{\bar{x}-x\}' [L_R] [\varphi] \left(\frac{2}{\rho_0 v_0^2} \Gamma_{\lambda}^L + [\varphi]' [L_R] [\varphi] \right)^{-1} [\varphi]' [L_I] \{1\} \quad (3-140)$$

$$C_{L\dot{\theta}}^F = C_{L\dot{\theta}} - \{1\}' [L_R] [\varphi] \left(\frac{2}{\rho_0 v_0^2} \Gamma_{\lambda}^L + [\varphi]' [L_R] [\varphi] \right)^{-1} [\varphi]' [L_I] \{\bar{x}-x\} \quad (3-141)$$

$$C_{M\dot{\theta}}^F = C_{M\dot{\theta}} - \{\bar{x}-x\}' [L_R] [\varphi] \left(\frac{2}{\rho_0 v_0^2} \Gamma_{\lambda}^L + [\varphi]' [L_R] [\varphi] \right)^{-1} [\varphi]' [L_I] \{\bar{x}-x\} \quad (3-142)$$

$$C_{L\gamma}^F = C_{L\gamma} - \{1\}' [L_R] [\varphi] \left(\frac{2}{\rho_0 v_0^2} \Gamma_{\lambda}^L + [\varphi]' [L_R] [\varphi] \right)^{-1} [\varphi]' [L_R] \{\varphi_{\gamma}\} \quad (3-143)$$

$$C_{M\gamma}^F = C_{M\gamma} - \{\bar{x}-x\}' [L_R] [\varphi] \left(\frac{2}{\rho_0 v_0^2} \Gamma_{\lambda}^L + [\varphi]' [L_R] [\varphi] \right)^{-1} [\varphi]' [L_R] \{\varphi_{\gamma}\} \quad (3-144)$$

$$C_{H\alpha}^F = C_{H\alpha} - \{\varphi_{\gamma}\}' [L_R] [\varphi] \left(\frac{2}{\rho_0 v_0^2} \Gamma_{\lambda}^L + [\varphi]' [L_R] [\varphi] \right)^{-1} [\varphi]' [L_I] \{1\} \quad (3-145)$$

$$C_{H\dot{\theta}}^F = C_{H\dot{\theta}} - \{\varphi_{\gamma}\}' [L_R] [\varphi] \left(\frac{2}{\rho_0 v_0^2} \Gamma_{\lambda}^L + [\varphi]' [L_R] [\varphi] \right)^{-1} [\varphi]' [L_I] \{\bar{x}-x\} \quad (3-146)$$

$$C_{H\gamma}^F = C_{H\gamma} - \{\varphi_{\gamma}\}' [L_R] [\varphi] \left(\frac{2}{\rho_0 v_0^2} \Gamma_{\lambda}^L + [\varphi]' [L_R] [\varphi] \right)^{-1} [\varphi]' [L_R] \{\varphi_{\gamma}\} \quad (3-147)$$

3.1.2.4 "Unit" Internal Loads Based on the Quasi-Rigid Approximation

We can now use the solutions to the quasi-rigid equations to obtain loads consistent with this approximation. In Equation 3-109 we make the quasi-rigid assumption and obtain

$$\{\ddot{p}\} = \{1\} \ddot{\gamma} + \{\bar{x}-x\} \ddot{\theta} \quad (3-148)$$

$$\{\dot{p}\} = \{1\} \dot{\gamma} + \{\bar{x}-x\} \dot{\theta} \quad (3-149)$$

$$\{p\} = \{1\} \gamma + \{\bar{x}-x\} \theta + [\varphi] \{q\} \quad (3-150)$$

but from Equations 3-136, 3-137, and 3-132 we have

$$\ddot{\gamma} = - \frac{\rho_0 v_0^2}{2M} (C_{L\alpha}^F a + C_{L\dot{\theta}}^F \dot{\theta} + C_{L\gamma}^F \gamma) \quad (3-151)$$

$$\ddot{\theta} = - \frac{\rho_0 v_0^2}{2I} (C_{M\alpha}^F a + C_{M\dot{\theta}}^F \dot{\theta} + C_{M\gamma}^F \gamma) \quad (3-152)$$

Controls

(The control surface relation given in Equation 3-138 is of interest in defining the demands on the servo to produce a required control surface deflection, γ .)

$$\{q\} = - \left(\frac{2}{\rho \omega^2} \Gamma' \lambda_J + [\varphi]' [L_R] [\varphi] \right)^{-1} \left([L_I] \{I\} a + [L_I] \{ \bar{x} - x \} \frac{\dot{\theta}}{V_\omega} + [L_R] \{ \varphi_p \} \gamma \right) \quad (3-153)$$

where we have introduced the rigid-body angle-of-attack

$$\alpha = \frac{\dot{I}}{V_\omega} - \theta \quad (3-154)$$

We may simplify the discussion further by introducing the following notation:

$$\left\{ \frac{\partial q}{\partial a} \right\} = - \left(\frac{2}{\rho \omega^2} \Gamma' \lambda_J + [\varphi]' [L_R] [\varphi] \right)^{-1} [\varphi]' [L_I] \{I\} \quad (3-155)$$

$$\left\{ \frac{\partial q}{\partial \theta} \right\} = - \left(\frac{2}{\rho \omega^2} \Gamma' \lambda_J + [\varphi]' [L_R] [\varphi] \right)^{-1} [\varphi]' [L_I] \{ \bar{x} - x \} \quad (3-156)$$

$$\left\{ \frac{\partial q}{\partial \gamma} \right\} = - \left(\frac{2}{\rho \omega^2} \Gamma' \lambda_J + [\varphi]' [L_R] [\varphi] \right)^{-1} [\varphi]' [L_R] \{ \varphi_p \} \quad (3-157)$$

so that

$$\{q\} = \left\{ \frac{\partial q}{\partial a} \right\} \alpha + \left\{ \frac{\partial q}{\partial \theta} \right\} \frac{\dot{\theta}}{V_\omega} + \left\{ \frac{\partial q}{\partial \gamma} \right\} \gamma \quad (3-158)$$

These equations may now be substituted into Equation 3-80 to obtain the quasi-rigid approximation to the loads

$$\begin{aligned} \{L\} \equiv \begin{Bmatrix} \{V\} \\ \{M\} \end{Bmatrix} &= [R] [A] \{I\} \frac{\rho \omega^2}{2M} (C_{L\alpha}^F \alpha + C_{L\dot{\theta}}^F \frac{\dot{\theta}}{V_\omega} + C_{L\gamma}^F \gamma) \\ &+ [R] [A] \{ \bar{x} - x \} \frac{\rho \omega^2}{2I} (C_{M\alpha}^F \alpha + C_{M\dot{\theta}}^F \frac{\dot{\theta}}{V_\omega} + C_{M\gamma}^F \gamma) \\ &+ \frac{\rho \omega^2}{2} [R] [L_I] \{I\} \alpha + \frac{\rho \omega^2}{2} [R] [L_I] \{ \bar{x} - x \} \frac{\dot{\theta}}{V_\omega} \\ &- \frac{\rho \omega^2}{2} [R] [L_R] [\varphi] \left(\left\{ \frac{\partial q}{\partial a} \right\} \alpha + \left\{ \frac{\partial q}{\partial \theta} \right\} \frac{\dot{\theta}}{V_\omega} + \left\{ \frac{\partial q}{\partial \gamma} \right\} \gamma \right) \\ &+ [R] \{ \tau \} \Gamma \end{aligned} \quad (3-159)$$

Contrails

Now, since

$$\Gamma = \frac{\rho v_0^2}{2} (C_{H\alpha}^F \alpha + C_{H\dot{\theta}}^F \frac{\dot{\theta}}{v_0} + C_{H\gamma}^F \gamma) \quad (3-160)$$

we can write the loads in the form of "unit solutions."

$$\{L\} = \left\{ \frac{\partial L}{\partial \alpha} \right\} \alpha + \left\{ \frac{\partial L}{\partial \dot{\theta}} \right\} \frac{\dot{\theta}}{v_0} + \left\{ \frac{\partial L}{\partial \gamma} \right\} \gamma \quad (3-161)$$

where

$$\left\{ \frac{\partial L}{\partial \alpha} \right\} = \frac{\rho v_0^2}{2} [R] \left([A] \{ \dot{\gamma} \} \frac{C_M^F}{M} + [A] \{ \bar{x} - x \} \frac{C_{M\alpha}^F}{I} + [L_I] \{ \dot{\theta} \} \right. \\ \left. - [L_R] \{ \varphi \} \frac{\partial \varphi}{\partial \alpha} \right) + \{ \eta \} C_{H\alpha}^F \quad (3-162)$$

$$\left\{ \frac{\partial L}{\partial \dot{\theta}} \right\} = \frac{\rho v_0^2}{2} [R] \left([A] \{ \dot{\gamma} \} \frac{C_M^F}{M} + [A] \{ \bar{x} - x \} \frac{C_{M\dot{\theta}}^F}{I} + [L_I] \{ \bar{x} - x \} \right. \\ \left. - [L_R] \{ \varphi \} \frac{\partial \varphi}{\partial \dot{\theta}} \right) + \{ \eta \} C_{H\dot{\theta}}^F$$

$$\left\{ \frac{\partial L}{\partial \gamma} \right\} = \frac{\rho v_0^2}{2} [R] \left([A] \{ \dot{\gamma} \} \frac{C_M^F}{M} + [A] \{ \bar{x} - x \} \frac{C_{M\gamma}^F}{I} \right. \\ \left. - [L_R] \{ \varphi \} \frac{\partial \varphi}{\partial \gamma} \right) + \{ \eta \} C_{H\gamma}^F$$

3.1.2.5 The Aeroelastic Effects of Large Axial Loads on Lateral Motions

In our discussions of beam theory in Paragraph 2.3.3.1, we assumed that the specific strain energy for a particle of a beam is given by

$$u(x, y, z, t) = \frac{1}{2} E \epsilon_{xx}^2 \quad (3-165)$$

Contrails

and that the strain is related to the displacements by

$$\epsilon_{xx} = -z \frac{\partial^2 b_z}{\partial x^2} \quad (3-166)$$

In the presence of large axial loads, however, a more precise description of strain must be used. The Lagrangian-coordinate strain for arbitrary displacements of a one-dimensional beam (whose curvature is small) is¹

$$\epsilon_{xx} = -z \frac{\partial^2 b_z}{\partial x^2} + \frac{\partial b_x}{\partial x} + \frac{1}{2} \left(\frac{\partial b_x}{\partial x} \right)^2 + \frac{1}{2} \left(\frac{\partial b_z}{\partial x} \right)^2 \quad (3-167)$$

The last three terms are the contribution from longitudinal strain of the neutral surface. On the basis that the longitudinal strain is small, we have

$$\left(\frac{\partial b_x}{\partial x} \right)^2 \ll \left(\frac{\partial b_x}{\partial x} \right) \quad (3-168)$$

so that

$$\epsilon_{xx} = -z \frac{\partial^2 b_z}{\partial x^2} + \frac{\partial b_x}{\partial x} + \frac{1}{2} \left(\frac{\partial b_z}{\partial x} \right)^2 \quad (3-169)$$

Using Equation 2-56, the total strain energy is

$$U = \frac{1}{2} \int_0^L \left(\iint E z^2 dy dz \left(\frac{\partial^2 b_z}{\partial x^2} \right)^2 - 2 \iint E z dy dz \left(\frac{\partial^2 b_z}{\partial x^2} \right) \left(\frac{\partial b_x}{\partial x} + \frac{1}{2} \left(\frac{\partial b_z}{\partial x} \right)^2 \right) + \iint E dy dz \left(\frac{\partial b_x}{\partial x} + \frac{1}{2} \left(\frac{\partial b_z}{\partial x} \right)^2 \right)^2 \right) dx \quad (3-170)$$

For symmetrical cross sections, the second term is zero because

$$\iint E z dy dz = 0 \quad (3-171)$$

If we neglect the fourth order terms, $\left(\frac{\partial b_z}{\partial x} \right)^4$, then Equation 3-170 becomes

$$U = \frac{1}{2} \int_0^L \left[EI(x) \left(\frac{\partial^2 b_z}{\partial x^2} \right)^2 + EA(x) \left(\frac{\partial b_x}{\partial x} + \frac{1}{2} \left(\frac{\partial b_z}{\partial x} \right)^2 \right)^2 \right] dx \quad (3-172)$$

¹See Green and Zerna Theoretical Elasticity, Oxford, 1954.

The virtual work of the internal forces can be obtained from

$$\begin{aligned} \delta W &= -\delta U & (3-173) \\ &= -\int_0^L \delta p_z \left(-\frac{\partial^2}{\partial x^2} (EI \frac{\partial^2 p_z}{\partial x^2}) + \frac{\partial}{\partial x} (EA \frac{\partial p_x}{\partial x} \frac{\partial p_z}{\partial x}) \right) \\ &\quad + \delta p_x \left(\frac{\partial}{\partial x} (EA \frac{\partial p_x}{\partial x}) + \frac{1}{2} \frac{\partial^2}{\partial x^2} (EA (\frac{\partial p_z}{\partial x})^2) \right) dx. \end{aligned}$$

If we write the virtual work of external forces as

$$\int_0^L (\delta p_z P_z + \delta p_x P_x) dx \quad (3-174)$$

then using D'Alembert's Principle, the Principle of Virtual Work, in this case, becomes

$$\begin{aligned} \int_0^L \delta p_z \left(P_z + \frac{\partial^2}{\partial x^2} (EI \frac{\partial^2 p_z}{\partial x^2}) - \frac{\partial}{\partial x} (EA \frac{\partial p_x}{\partial x} \frac{\partial p_z}{\partial x}) - m \frac{\partial^2 p_z}{\partial t^2} \right) & (3-175) \\ + \delta p_x \left(P_x - \frac{\partial}{\partial x} (EA \frac{\partial p_x}{\partial x}) + \frac{EA}{2} \frac{\partial^2 p_z}{\partial x^2} - m A_x \right) dx &= 0 \end{aligned}$$

In this expression A_x is the uniform rectilinear acceleration of every particle parallel to the I -axis.

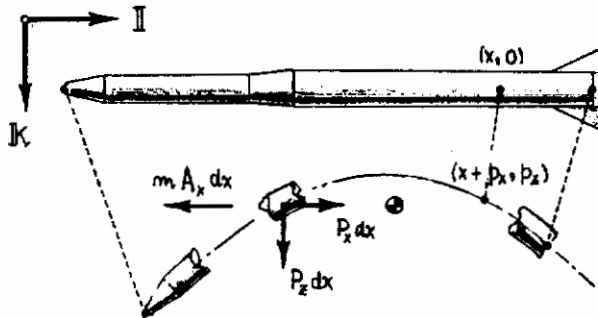

FIGURE 31 AXIALLY LOADED LAUNCH VEHICLE

Contrails

Since δP_x and δP_x are arbitrary, we must have

$$m \frac{\partial^2 b_x}{\partial t^2} = P_x + \frac{\partial^2}{\partial x^2} (EI \frac{\partial^2 b_x}{\partial x^2}) - \frac{\partial}{\partial x} (EA \frac{\partial P_x}{\partial x} \frac{\partial b_x}{\partial x}) \quad (3-176)$$

$$m A_x = P_x - \frac{\partial}{\partial x} (EA \frac{\partial b_x}{\partial x} + \frac{EA}{2} (\frac{\partial b_x}{\partial x})^2) \quad (3-177)$$

We cannot solve these nonlinear equations exactly; however, we can use the last equation to solve for $\frac{\partial b_x}{\partial x}$ and eliminate this term in the nonlinear part of the strain energy (Equation 3-172). This procedure would be equivalent to the first iteration in a Picard solution to the nonlinear Equations 3-176 and 3-177.

From Equation 3-177, we have then

$$EA \frac{\partial b_x}{\partial x} = - \int_0^x (P_x - m A_x) dx - \frac{EA}{2} (\frac{\partial b_x}{\partial x})^2 \quad (3-178)$$

If we introduce the definition,

$$N(x) = - \int_0^x (P_x - m(x) A_x) dx \quad (3-179)$$

then

$$\frac{\partial b_x}{\partial x} = \frac{N}{EA} - \frac{1}{2} (\frac{\partial b_x}{\partial x})^2 \quad (3-180)$$

Substituting this into the nonlinear term (only) in Equation 3-172, we obtain¹

¹If we denote the order-of-magnitude of N by κ and the order-of-magnitude of $(\frac{\partial b_x}{\partial x})$ by ϵ , then the limiting process is defined by

$$\frac{N}{2} (\frac{\partial b_x}{\partial x})^2 = \mu = a = \text{"constant"}$$

and

$$EA = \text{order-of-magnitude of } \kappa^2$$

If we then let $\epsilon \rightarrow 0$ and $\kappa \rightarrow \infty$, we have from Equation 3-180 that

$$\epsilon = \frac{\kappa}{k\epsilon} - \frac{1}{2} \kappa$$

and hence

$$\kappa \epsilon \rightarrow \kappa^2 \kappa^{-1} - \mu = 1 - \mu$$

Thus $N (\frac{\partial b_x}{\partial x})$ is of the same order-of-magnitude as $\frac{N}{2} (\frac{\partial b_x}{\partial x})^2$, and $EA (\frac{\partial b_x}{\partial x})$ is of the order-of-magnitude of

$$(k\epsilon)^2 = (1 - \mu)^2 = a \text{ "constant"}$$

$$U = \frac{1}{2} \int_0^L \left(EI(x) \left(\frac{\partial^2 \epsilon}{\partial x^2} \right)^2 + EA(x) \left(\frac{\partial \epsilon}{\partial x} \right)^2 + N(x) \left(\frac{\partial \epsilon}{\partial x} \right)^2 \right) dx \quad (3-181)$$

where, consistent with approximations already made, we have neglected terms in the strain energy of fourth order.

In the case of a slender missile the axial loads arise from distributed drag, thrust, and gravity (see Figure 35)

$$P_x = \frac{1}{2} \rho v^2 C_D(x) - T(x) \cos \epsilon(x) + m(x) g \sin \theta \quad (3-182)$$

where $T(x)$ is the magnitude of the thrust per unit of length along the missile and $\epsilon(x)$ is the misalignment of the thrust distribution from the body axis.

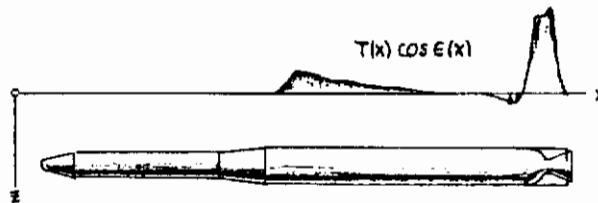

FIGURE 32 DISTRIBUTION OF AXIAL COMPONENT OF THRUST

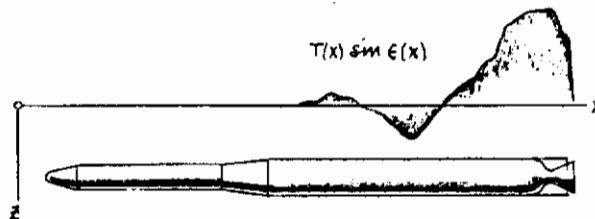

FIGURE 33 DISTRIBUTION OF LATERAL COMPONENT OF THRUST

Contrails

Substituting Equation 3-182 into Equation 3-179, we obtain

$$N(x) = - \int_0^x \left(\frac{\rho_0 v_0^2}{2} C_D(x) - T(x) \cos \epsilon(x) + m(x) q \sin \theta \right) - m(x) A_x \quad dx \quad (3-183)$$

We then note that

$$N(L) = - \int_0^L \left(\frac{\rho_0 v_0^2}{2} C_D(x) - T(x) \cos \epsilon(x) - m(x) A_x + m(x) q \sin \theta \right) dx = F_x - M A_x \quad (3-184)$$

where

$$F_x = \frac{\rho_0 v_0^2}{2} \int_0^L C_D(x) dx - \int_0^L T(x) \cos \epsilon(x) dx + q \sin \theta \int_0^L m(x) dx \quad (3-185)$$

= the total applied axial force

and

$$M = \int_0^L m(x) dx = \text{total mass} \quad (3-186)$$

From longitudinal equilibrium

$$F_x = M A_x \quad (3-187)$$

so

$$N(L) = 0 \quad (3-188)$$

We can use the relation

$$A_x - q \sin \theta = \frac{\frac{\rho_0 v_0^2}{2} \int_0^L C_D(x) dx - \int_0^L T(x) \cos \epsilon(x) dx}{M} \quad (3-189)$$

to eliminate the axial acceleration from Equation 3-183 and express $N(x)$ in terms of the drag and thrust only.

$$N(x) = - \frac{\rho_0 v_0^2}{2} \int_0^x \left(C_D(x) - \frac{m(x)}{M} \int_0^L C_D(\xi) d\xi \right) dx + \int_0^x \left(T(x) \cos \epsilon(x) - \frac{m(x)}{M} \int_0^L T(\xi) \cos \epsilon(\xi) d\xi \right) dx \quad (3-190)$$

Contrails

The third term in Equation 3-181 can then be treated in the same manner as the first term (the second term which is involved in longitudinal dynamics does not concern us here). Using the interpolation formula, we have

$$\frac{\partial b}{\partial x} = \frac{1}{l_i} \{0 \quad 1 \quad 2s \quad 3s^2\} [s]_i \{b\}_i \quad (3-191)$$

$x_{i-1} \leq x \leq x_i$

Using this in Equation 3-181, we obtain

$$U = \frac{1}{2} \int_0^L N(x) \left(\frac{\partial b}{\partial x}\right)^2 dx + \frac{1}{2} \int_0^L EI(x) \left(\frac{\partial^2 b}{\partial x^2}\right)^2 dx \quad (3-192)$$

$$= \frac{1}{2} \sum_{i=1}^N \{b\}_i' [K]_i \{b\}_i + \{b\}_i' [N]_i \{b\}_i$$

where, if we make the same approximations discussed in Paragraph 2.3.3.4, we obtain

$$[N]_i = \frac{N_i}{120l_i} \begin{bmatrix} 4 & -7 & 2 & 1 \\ -7 & 136 & -131 & 2 \\ 2 & -131 & 136 & -7 \\ 1 & 2 & -7 & 4 \end{bmatrix} \quad (3-193)$$

with N_i = average value of $N(x)$ on the i^{th} interval.

The appropriate expression for the contribution of axial loads that is valid in the first and last bay is

$$[N]_i = \frac{N_i}{120l_i} \begin{bmatrix} 126 & -132 & 6 \\ -132 & 144 & -12 \\ 6 & -12 & 6 \end{bmatrix} \quad \text{for } i = 1 \quad (3-194)$$

(3-195)

$$[N]_i = \frac{N_i}{120L_i} \begin{bmatrix} 126 & -132 & 6 \\ -132 & 144 & -12 \\ 6 & -12 & 6 \end{bmatrix} \text{ for } i = N$$

Using

$$\{p\}_i = [T]_i \{p\} \quad (3-196)$$

we have

$$U = \frac{1}{2} \left(\{p\}' [K] \{p\} + \frac{1}{2} \{p\}' [N] \{p\} \right) \quad (3-197)$$

where

$$[N] = \sum_{i=1}^N [T]_i' [N]_i [T]_i \quad (3-198)$$

3.1.2.6 Modification of the Loads Equations to Include Gravity, Thrust, Drag, and Air Loads Due to Asymmetries

In our considerations of axial loads in the preceding section, we included only the component of thrust parallel to the x-axis. If we were to include only this effect, we would obtain unrealistic results in the consideration of loads and stability of the missile. To illustrate, for the rigid missile if we were to assume that the thrust acts tangent to the missile axis, then the moment of the thrust (assumed concentrated at $x=L$) about the center of mass is given by a contribution from the axial component, $T \cos \theta ((L-\bar{x}) \sin \theta)$

and a contribution from the lateral component, $-T \sin \theta ((L-\bar{x}) \cos \theta)$

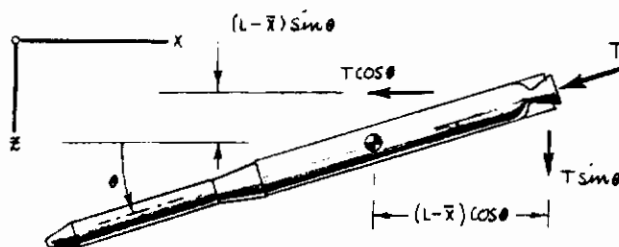

FIGURE 34 MOMENT OF THE THRUST FOR A RIGID MISSILE

The total moment of the thrust is the sum of two effects

$$T \cos \theta (L - \bar{x}) \sin \theta - T \sin \theta (L - \bar{x}) \cos \theta$$

which is identically zero, reflecting the fact that the thrust, in this case, acts through the center of mass. It can be shown that the moment contributed by the axial component of thrust, in the case of a flexible missile, is exactly accounted for when the axial effects are considered as in the previous section. The moment contributed by the lateral component is computed in a straightforward fashion from the virtual work of the distributed lateral forces. The argument presented here applies only to forces, like the thrust, which act tangent to the body. The drag, for example, is assumed to act parallel to the x-axis (i.e., to the free-stream) independently of the motions of the body.

3.1.2.6.1 The Virtual Work of Distributed Lateral Forces

The virtual work of gravity, thrust, and air loads at zero angle-of-attack is given by

$$\begin{aligned} \delta W = & - \int_0^L \delta p_z \left(m(x) q \cos \vartheta + T(x) \sin \epsilon(x) \right. \\ & \left. + \left(\frac{\partial p_z}{\partial x} \right) T(x) \cos \epsilon(x) \right) dx \\ & - \frac{1}{2} \rho a V^2 \int_0^L \delta p_z C_{L0}(x) dx \end{aligned} \quad (3-199)$$

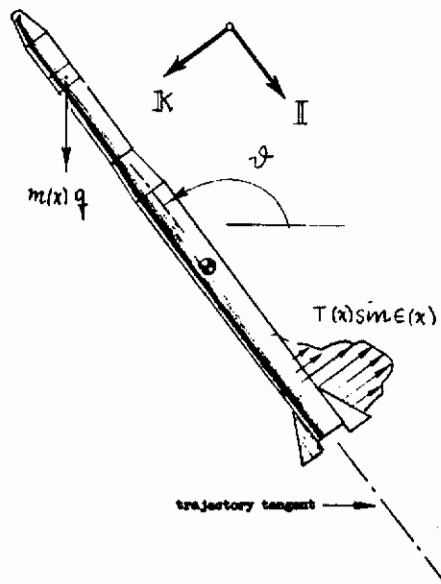

FIGURE 35 DISTRIBUTED LATERAL FORCES

If the thrust is assumed to be concentrated, then

$$-\int_0^L \delta p_z \left(T(x) \sin \epsilon(x) + \left(\frac{\partial p_z}{\partial x} \right) T(x) \cos \epsilon(x) \right) dx$$

is replaced by

$$- \left(\delta p_z (T \sin \epsilon + \left(\frac{\partial p_z}{\partial x} \right) T \cos \epsilon) \right)_{x=L}$$

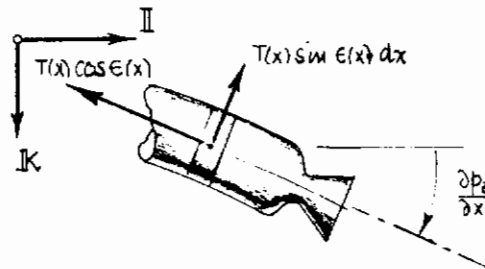

FIGURE 36 DISTRIBUTED THRUST FORCE ON THE FLEXIBLE MISSILE

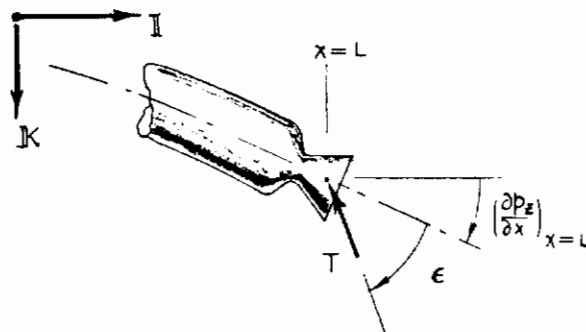

FIGURE 37 CONCENTRATED THRUST FORCE MISALIGNED AT AN ANGLE, ϵ

Contrails

In order to compute the generalized forces, we may use the interpolation equation (Equation 3-2) to express Equation 3-199 in terms of the generalized coordinates, p_i .

$$p_z(x,t) = \{1 \ \xi \ \xi^2 \ \xi^3\} [J]_i^{-1} [T]_i \{p\} \quad (3-200)$$

$$\text{for } x_{i-1} \leq x \leq x_i$$

which we may write as

$$p_z(x,t) = \{h_z(x)\}' \{p\} \quad (3-201)$$

where

$$\{h_z(x)\}' = \{1 \ \xi \ \xi^2 \ \xi^3\} [J]_i^{-1} [T]_i \quad (3-202)$$

$$\text{for } x_{i-1} \leq x \leq x_i$$

(see also Equation 2-451 and Figure 12)

we then can write

$$\begin{aligned} \delta W = & -\{sp\}' \int_0^L \{h_z\}' / m(x) q \cos \theta \, dx & (3-203) \\ & -\{sp\}' \int_0^L \{h_z\}' T(x) \sin \epsilon(x) \, dx \\ & -\{sp\}' \int_0^L \{h_z\}' \left\{ \frac{dh_z}{dx} \right\}' T(x) \cos \epsilon(x) \, dx \{p\} \\ & - \frac{1}{2} \rho_0 v_0^2 \{sp\}' \int_0^L \{h_z\}' C_D(x) \, dx \end{aligned}$$

Now, when

$$\{p\} = \{1\} \quad (3-204)$$

we have

$$p(x,t) = 1 \quad \text{for all } x. \quad (3-205)$$

Contrails

so that

$$V = \{h_z\}' \{I\} \quad (3-206)$$

and the virtual work of gravity forces can be written as

$$- \{Sp\}' \int_0^L \{h_z\} \{h_z\}' m(x) dx \{I\} g \cos \theta$$

but

$$[A] = \int_0^L \{h_z\} \{h_z\}' m(x) dx = \text{the inertia matrix} \quad (3-207)$$

so that the gravity forces are

$$\delta W = - \{Sp\}' [A] \{I\} g \cos \theta \quad (3-208)$$

If we introduce

$$\{H_0\} = \int_0^L \{h_z\} T(x) \sin \epsilon(x) dx. \quad (3-209)$$

and

$$[H] = \int_0^L \{h_z\} \left\{ \frac{dh_z}{dx} \right\}' T(x) \cos \epsilon(x) dx \quad (3-210)$$

and

$$\{L_0\} = \int_0^L \{h_z\} C_{L_0}(x) dx \quad (3-211)$$

the virtual work of the distributed lateral forces in Equation 3-199 becomes

$$\begin{aligned} \delta W = & - \{Sp\}' [A] \{I\} g \cos \theta \\ & - \{Sp\}' (\{H_0\} + [H] \{p\}) \\ & - \frac{1}{2} \rho \omega^2 \{Sp\}' \{L_0\} \end{aligned} \quad (3-212)$$

3.1.2.6.2 The Loads Equations Including Axial and Lateral Forces

The kinetic energy, from Equation 3-33, is

$$T = \frac{1}{2} \dot{\mathbf{p}}^T [\mathbf{A}] \dot{\mathbf{p}} \quad (3-213)$$

The strain energy, including axial load effects, is

$$U = \frac{1}{2} \mathbf{p}^T [\mathbf{K}] \mathbf{p} + \frac{1}{2} \mathbf{p}^T [\mathbf{N}] \mathbf{p} \quad (3-214)$$

and the virtual work of all external forces is

$$\begin{aligned} \delta W = & - \frac{1}{2} \rho_0 v_0^2 \{ \delta \mathbf{p}^T ([L_R] \mathbf{H} \mathbf{p} + \frac{1}{v_0} [L_I] \dot{\mathbf{H}} \mathbf{p}) + \{ \delta \mathbf{p} \}^T \boldsymbol{\eta} \} \Gamma \\ & - \{ \delta \mathbf{p} \}^T [\mathbf{A}] \mathbf{H} \mathbf{1} \} q \cos \vartheta - \{ \delta \mathbf{p} \}^T (\{ \mathbf{H}_0 \} + [\mathbf{H}] \mathbf{H} \mathbf{p}) \\ & - \frac{1}{2} \rho_0 v_0^2 \{ \delta \mathbf{p} \}^T \{ \mathbf{L}_0 \} \end{aligned} \quad (3-215)$$

The control deflection is related to the generalized coordinates of the system by

$$\boldsymbol{\eta} = \boldsymbol{\eta} \{ \mathbf{p} \} \quad (3-216)$$

We may also generalize the previous results by accounting for energy dissipation in the structure through Rayleigh's dissipation function (see Paragraph 2.2.2)

$$R = \frac{1}{2} \dot{\mathbf{p}}^T [\mathbf{B}] \dot{\mathbf{p}} \quad (3-217)$$

Employing Lagrange's equations in conjunction with the above system of equations, we obtain

$$\begin{aligned} & \mathbf{M} \ddot{\mathbf{p}} + [\mathbf{B}] \dot{\mathbf{p}} + [\mathbf{K}] \mathbf{p} + [\mathbf{N}] \mathbf{p} \\ & = - \frac{1}{2} \rho_0 v_0^2 ([L_R] \mathbf{H} \mathbf{p} + \frac{1}{v_0} [L_I] \dot{\mathbf{H}} \mathbf{p} + \{ \mathbf{L}_0 \}) \\ & - ([\mathbf{H}] \mathbf{H} \mathbf{p} + \{ \mathbf{H}_0 \}) - [\mathbf{A}] \mathbf{H} \mathbf{1} \} q \cos \vartheta + \boldsymbol{\eta} \Gamma \end{aligned} \quad (3-218)$$

Contrails

If we assume that the structural loads are given by

$$\{F\} = [K] \{p\} + [B] \{\dot{p}\} \quad (3-219)$$

then the loads equations are:

$$\begin{aligned} \{F\} = & -[A] \{\ddot{p}\} - [N] \{\dot{p}\} - \frac{1}{2} \rho v_0^2 ([L_R] \{p\} + \frac{1}{v_0} [L_I] \{\dot{p}\} + \{L_0\}) \\ & - [A] \{I\} q \cos \psi + \{\eta\} \Gamma - [H] \{p\} - \{H_0\} \end{aligned} \quad (3-220)$$

The internal loads, member loads, and stresses are related to these loads by a simple transformation. The modal equations of motion that are compatible with the above equations are given by

$$\begin{aligned} & [M] \{\ddot{q}\} + [R] \{\dot{q}\} + [F] \{q\} + [U] \{q\} \\ & + \frac{1}{2} \rho v_0^2 ([C_R] \{q\} + \frac{1}{v_0} [C_I] \{\dot{q}\}) \\ & = - \frac{1}{2} \rho v_0^2 [\varphi] \{L_0\} - [\varphi]' [A] \{I\} q \cos \psi \\ & \quad - [\varphi]' \{H_0\} + [\varphi] \{\eta\} \Gamma \end{aligned} \quad (3-221)$$

where

$$[U] = [\varphi]' ([N] + [H]) [\varphi] \quad (3-222)$$

and

$$[R] = [\varphi]' [B] [\varphi] \quad (3-223)$$

3.1.3 Aeroelastic Stability

3.1.3.1 "Static" Stability of a Free Missile with Locked Controls

Our preliminary discussion will exclude the effect of axial loads even though these effects are a source of destabilizing moments on the unrestrained missile. We will assume the system to be completely described, for stability purposes, by its kinetic energy, strain energy, and the virtual work done by aerodynamic forces. In this section the control surface is assumed to be constrained at the $\gamma = 0$ position.

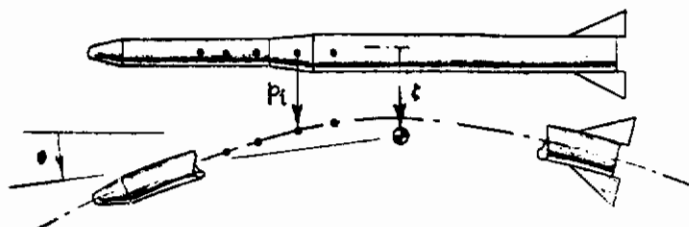

FIGURE 38 THE UNCONTROLLED MISSILE

The equations governing the motion of the system in this case are obtained from Equations 3-27, 3-28, and 3-29 by setting $\gamma = 0$

$$T = \frac{1}{2} \dot{p}^T [A] \dot{p} \quad (3-224)$$

$$U = \frac{1}{2} p^T [K] p \quad (3-225)$$

$$\delta W = -\frac{1}{2} \rho v_\infty^2 \delta p^T [\Lambda] \xi \quad (3-226)$$

where

$$\xi = [\Delta] p + \frac{1}{v_\infty} \dot{p} \quad (3-227)$$

The fact that the body is unrestrained is evidenced by (Equations 3-85 and 3-86)

$$[K] \xi = \{0\} \quad (3-228)$$

Contrails

$$[K]\{\bar{x} - x\} = \{0\} \quad (3-229)$$

Because of the subtle nature of the stability of an unrestrained body, it is best to introduce the subject by briefly discussing the complete dynamic stability which should cover static stability as a special case.

Lagrange's equations (Equation 2-64) may be applied to Equations 3-224, 3-225, and 3-226 to obtain the following equations of motion

$$[A]\{\ddot{p}\} + [K]\{\dot{p}\} + \frac{1}{2}\rho v_\infty^2 \left([\Lambda][\Delta]\dot{p} + \frac{1}{v_\infty} [\Lambda]\dot{p} \right) = \{0\} \quad (3-230)$$

To investigate the stability of the system described by these linear differential equations, we shall use the conventional Laplace transform techniques. Application of the Laplace transform,

$$\{\bar{p}(s)\} = \int_0^\infty \{p(t)\} e^{-st} dt, \quad (3-231)$$

to Equation 3-230 yields

$$\left(s^2[A] + s \frac{\rho v_\infty^2}{2} [\Lambda] + [K] + \frac{\rho v_\infty^2}{2} [\Lambda][\Delta] \right) \{\bar{p}\} = \{0\} \quad (3-232)$$

The stability of the system is governed by the equation

$$\Delta\left(s, \frac{\rho v_\infty^2}{2}\right) = \left| s^2[A] + s \frac{\rho v_\infty^2}{2} [\Lambda] + [K] + \frac{\rho v_\infty^2}{2} [\Lambda][\Delta] \right| = 0 \quad (3-233)$$

In the conventional sense the static stability would be governed by the special case,

$$\lim_{s \rightarrow 0} \Delta\left(s, \frac{\rho v_\infty^2}{2}\right) = \Delta\left(0, \frac{\rho v_\infty^2}{2}\right) = 0 \quad (3-234)$$

which yields

$$\left| [K] + \frac{1}{2}\rho v_\infty^2 [\Lambda][\Delta] \right| = 0 \quad (3-235)$$

Contrails

The associated eigenvalue problem is given by setting $s = 0$ in Equation 3-232

$$([K] + \frac{1}{2} \rho_{\infty} V_{\infty}^2 [A][\Delta]) \{ \bar{p} \} = \{ 0 \} \quad (3-236)$$

It is quickly shown that this problem has an infinity of eigenvalues. To illustrate, for any value of the dynamic pressure, $\frac{1}{2} \rho_{\infty} V_{\infty}^2$, we have

$$[K] \{ \bar{p} \} = \{ 0 \} \quad (3-237)$$

This is true because

$$[K] \{ \bar{p} \} = \{ 0 \} \quad (3-238)$$

from Equation 3-228, and

$$[\Delta] \{ \bar{p} \} = \{ 0 \} \quad (3-239)$$

from Equation 3-67. As a consequence, all the coefficients in the polynomial $\Delta(0, \frac{1}{2} \rho_{\infty} V_{\infty}^2)$ are zero. It is more convenient, perhaps, to say that the problem has no eigenvalues.

The physical significance of these conclusions is that the system governed by Equation 3-230 is, in the strictest sense, incipiently unstable at any air-speed or altitude. The system, however, acts passively and the only result of the "instability" is the fact that the missile can translate laterally in a quasi-static fashion without producing forces which would restore it to its initial position.

The straightforwardness of this problem is also obscured in the dynamic case. We will find that Equation 3-233 has a repeated zero root in s (for any fixed value of the dynamic pressure). The result of our discussion in this section will show that the logical criterion for "static" stability is that

$$\lim_{s \rightarrow 0} \frac{\Delta(s, \frac{1}{2} \rho_{\infty} V_{\infty}^2)}{s^2} = 0 \quad (3-240)$$

The lowest value of dynamic pressure which satisfies this equation will be called the "dynamic pressure of divergence."

3.1.3.1.1 Divergence for the Vehicle in Rectilinear Flight

In spite of the fact that the missile is inherently unstable in the static case, it is instructive to look at the problem from a physical standpoint and imagine an artificial set of forces which constantly maintain lateral equilibrium. To insure that the problem is uniquely defined, we will require that the true center of mass of the missile move with constant velocity, V_∞ , along a straight path. The instantaneous displacement of the center of mass is given by (see the comments regarding Equation 3-92)

$$\dot{z} = \frac{1}{M} \{1\}' [A] \{p\} \quad (3-241)$$

The requirement of rectilinear flight is then equivalent to $\dot{z} = 0$ which leads to the following constraint on the generalized coordinates, p_i .

$$\{1\}' [A] \{p\} = 0 \quad (3-242)$$

In the static case,

$$\{p\} = \{0\} \quad (3-243)$$

and the governing equations are given by Equations 3-225 and 3-226

$$U = \frac{1}{2} \{p\}' [K] \{p\} \quad (3-244)$$

$$\delta W = -\frac{1}{2} \rho_\infty V_\infty^2 \{p\}' [\Lambda] [\Delta] \{p\} \quad (3-245)$$

subject to the constraint,

$$\{1\}' [A] \{p\} = \{0\} \quad (3-246)$$

3.1.3.1.1.1 Collocation Method

Using Lagrange's equations for a redundant set of coordinates (Equation 2-79 of Paragraph 2.1.2.2), we have, in this case,

$$\frac{\partial U}{\partial p_i} = \lambda \frac{\partial}{\partial p_i} (\{1\}' [A] \{p\}) + P_i \quad (3-247)$$

$$\delta W = \sum_i \delta p_i P_i \quad (3-248)$$

Contrails

where λ is Lagrange's undetermined multiplier corresponding to the constraint, $\zeta = 0$. Using Equations 3-244 and 3-245 in Equation 3-247, we obtain

$$[K]\{p\} = \lambda [A]\{i\} - \frac{1}{2}\rho_0 v_0^2 [A][\Delta]\{p\} \quad (3-249)$$

For the purpose of arriving at an eigenvalue problem governing the effective loads instead of displacements, we introduce

$$\{F\} = [K]\{p\} \quad (3-250)$$

We can then write Equation 3-249 as

$$\{F\} = \lambda [A]\{i\} - \frac{1}{2}\rho_0 v_0^2 [A][\Delta]\{p\} \quad (3-251)$$

Even though $[K]$ is singular it is possible to rewrite Equation 3-250 as

$$\{p\} = \{i\} + \{\bar{x}-x\}\theta + [\Gamma][\Delta]\{F\} \quad (3-252)$$

provided

$$\{i\}'\{F\} = 0 \quad (3-253)$$

and

$$\{\bar{x}-x\}'\{F\} = 0 \quad (3-254)$$

This is a special application of the result we obtained in Equation 2-256 of Paragraph 2.2.3.4. Equations 3-253 and 3-254, in this case, correspond to Equation 2-258 of the same paragraph.

Using Equation 3-251, Equations 3-253 and 3-254 lead to

$$\lambda \{i\}'[A]\{i\} - \frac{1}{2}\rho_0 v_0^2 \{i\}'[A][\Delta]\{p\} = 0 \quad (3-255)$$

$$\lambda \{\bar{x}-x\}'[A]\{i\} - \frac{1}{2}\rho_0 v_0^2 \{\bar{x}-x\}'[A][\Delta]\{p\} = 0 \quad (3-256)$$

Contrails

We can use the first equation to eliminate λ from Equation 3-251

$$\lambda = \frac{1}{\{1\}'[A]\{1\}} \frac{1}{2} \rho_0 v_0^2 \{1\}'[A][\Delta]\{p\} \quad (3-257)$$

Substituting this into Equation 3-251, we obtain

$$\{F\} = -\rho_0 \frac{v_0^2}{2} \left(\Gamma_1 - \frac{1}{M} [A] \{1\} \{1\}' \right) [A][\Delta]\{p\} \quad (3-258)$$

where we have used Equation 3-45,

$$\{1\}'[A]\{1\} = M \quad (3-259)$$

Using Equation 3-47,

$$\{\bar{x} - x\}'[A]\{1\} = 0 \quad (3-260)$$

in Equation 3-256 along with Equation 3-252, we obtain

$$\{\bar{x} - x\}'[A][\Delta] \left(\{1\}\{p\} + \{\bar{x} - x\}\theta + [\Gamma]'[E]\{F\} \right) = 0 \quad (3-261)$$

Further, if we make use of (Equations 3-66 and 3-67)

$$[\Delta]\{1\} = \{0\} \quad (3-262)$$

and

$$[\Delta]\{\bar{x} - x\} = -\{1\} \quad (3-263)$$

then from Equation 3-261, we obtain

$$\theta = \frac{1}{\{\bar{x} - x\}'[A]\{1\}} \{\bar{x} - x\}'[A][\Delta][\Gamma]'[E]\{F\} \quad (3-264)$$

Contrails

where we may recognize (from Equation 3-63) that

$$\{\bar{x}-x\}'[\Lambda]\{1\} = C_{M\alpha} \quad (3-265)$$

Since $\zeta = 0$, we have

$$\{p\} = \{\bar{x}-x\}\theta + [\Gamma]'[E]\{F\} \quad (3-266)$$

and using Equation 3-252

$$[\Lambda][\Delta]\{p\} = -[\Lambda]\{1\}\theta + [\Lambda][\Delta][\Gamma]'[E]\{F\} \quad (3-267)$$

and from Equation 3-264,

$$[\Lambda][\Delta]\{p\} = \left(r_{11} - \frac{1}{C_{M\alpha}}[\Lambda]\{1\}\{\bar{x}-x\}' \right) [\Lambda][\Delta][\Gamma]'[E]\{F\} \quad (3-268)$$

Substituting this into Equation 3-258, we obtain

$$[Z][\Lambda][\Delta][\Gamma]'[E]\{F\} = \frac{2}{\rho a V_a^2} \{F\} \quad (3-269)$$

where

$$[Z] = \left(r_{11} - \frac{1}{M}[\Lambda]\{1\}\{1\}' \right) \left(\frac{1}{C_{M\alpha}}[\Lambda]\{1\}\{\bar{x}-x\}' - r_{11} \right) \quad (3-270)$$

This equation can be solved by iteration in much the same way as the equation governing the vibration modes (Equations 2-220 or 2-279 of Paragraph 2.2.3.4). The result converges to the lowest value of dynamic pressure and the corresponding distribution of effective loads¹. Figure 39 shows the results of the application of this method to data for the NASA Scout solid-propellant launch vehicle.

¹The method, presented here, of introducing the loads as eigenvectors instead of the displacements is due to Vernon L. Alley, Jr. of the NASA Langley Research Center. We will make use of it again in the next section.

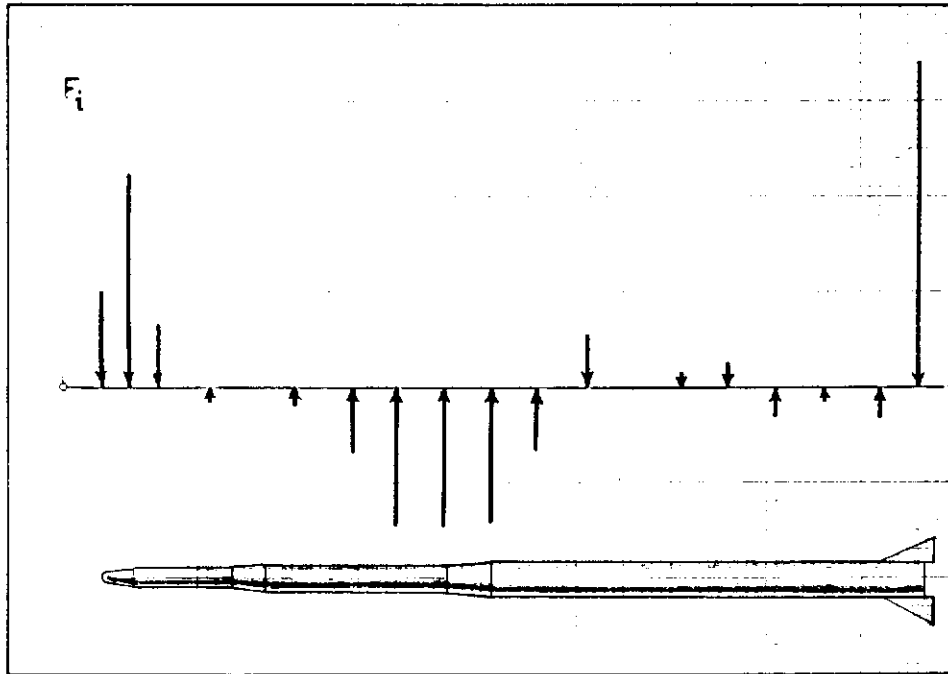

FIGURE 39 DISTRIBUTION OF LOADS IN THE DIVERGENCE MODE - CASE OF RECTILINEAR FLIGHT

3.1.3.1.1.2 Modal Method

An alternative to the above approach is to use a modal approximation. If we use Equation 3-109, we can write (for $\gamma = 0$)

$$\{p\} = \{f\}\xi - \{x-x_0\}\theta - \{q\}H\xi \quad (3-271)$$

Substituting this into Equations 3-224, 3-225, and 3-226, we obtain

$$T = \frac{1}{2} (M\dot{\xi}^2 + I\dot{\theta}^2 + \xi^T \{q\}^T [A] \{q\} H \xi) \quad (3-272)$$

$$U = \frac{1}{2} \xi^T \{q\}^T [K] \{q\} H \xi \quad (3-273)$$

Constraints

$$\begin{aligned}
 \delta W = & -\frac{1}{2} \rho_a v_a^2 \{ \delta q \}' [\varphi]' [\Lambda]' \left([\psi] \dot{q} \right) + \frac{1}{v_a} [\varphi] \dot{q} \} \\
 & - \frac{1}{2} \rho_a v_a^2 \delta J \left(C_{L\kappa} \left(\frac{\dot{\zeta}}{v_a} - \theta \right) + C_{L\theta} \frac{\dot{\theta}}{v_a} \right) \\
 & - \frac{1}{2} \rho_a v_a^2 \delta \Theta \left(C_{M\kappa} \left(\frac{\dot{\zeta}}{v_a} - \theta \right) + C_{M\theta} \frac{\dot{\theta}}{v_a} \right) \\
 & - \frac{1}{2} \rho_a v_a^2 \delta J \{ i \}' [\Lambda]' \left([\psi] \dot{q} \right) + \frac{1}{v_a} [\varphi] \dot{q} \} \\
 & - \frac{1}{2} \rho_a v_a^2 \delta \Theta \{ i \bar{x} - x \}' [\Lambda]' \left([\psi] \dot{q} \right) + \frac{1}{v_a} [\varphi] \dot{q} \} \\
 & - \frac{1}{2} \rho_a v_a^2 \{ \delta q \}' [\varphi]' [\Lambda]' \left(i \dot{\zeta} - \dot{\theta} + i \bar{x} - x \right) \frac{\dot{\theta}}{v_a}
 \end{aligned} \tag{3-274}$$

In the static case, we have $\dot{\zeta} = 0$, $\dot{\theta} = 0$, and also, consistent with the assumptions made in the first method, we constraint the center-of-mass to move in a straight line by taking

$$\zeta = 0 \tag{3-275}$$

Using Equation 2-179 of Paragraph 2.2.3.2

$$[\varphi]' [\kappa] [\varphi] = -\kappa \tag{3-276}$$

we obtain

$$U = \frac{1}{2} \{ \dot{q} \}' \kappa \{ \dot{q} \} \tag{3-277}$$

$$\begin{aligned}
 \delta W = & -\frac{1}{2} \rho_a v_a^2 \delta \Theta \{ i \bar{x} - x \}' [\Lambda]' [\psi] \dot{q} \} - C_{M\kappa} \dot{\theta} \\
 & - \frac{1}{2} \rho_a v_a^2 \{ \delta q \}' [\varphi]' [\Lambda]' [\psi] \dot{q} \} \\
 & - [\varphi]' [\Lambda] \dot{\theta} \}
 \end{aligned} \tag{3-278}$$

Constraints

The constraint, $\zeta = 0$, is satisfied explicitly in terms of modal generalized coordinates so that we may use Lagrange's equations for a set of independent generalized coordinates (Equation 2-64 of Paragraph 2.1.2.1) to obtain

$$\left(\Gamma_{\lambda}^1 + \frac{1}{2} \rho \omega^2 [\varphi]' [\Lambda] [\psi] \right) \{q\} = \frac{1}{2} \rho \omega^2 [\varphi]' [\Lambda] \{1\} \theta \quad (3-279)$$

$$\{\bar{x} - x\}' [\Lambda] [\psi] \{q\} - \{\bar{x} - x\}' [\Lambda] \{1\} \theta = 0 \quad (3-280)$$

using

$$c_{m\kappa} = \{\bar{x} - x\}' [\Lambda] \{1\} \quad (3-281)$$

we can eliminate θ from Equation 3-279 and substitute it into Equation 3-280 with the result that

$$\left(\Gamma_{\lambda}^1 + \frac{1}{2} \rho \omega^2 [\varphi]' \left(\Gamma_{11} - \frac{1}{c_{m\kappa}} [\Lambda] \{1\} \{\bar{x} - x\}' \right) [\Lambda] [\psi] \right) \{q\} = \{0\} \quad (3-282)$$

which we can also write as

$$- \Gamma_{\lambda}^1 [\varphi]' \left(\Gamma_{11} - \frac{1}{c_{m\kappa}} [\Lambda] \{1\} \{\bar{x} - x\}' \right) [\Lambda] [\psi] \{q\} = \frac{\lambda}{2 \rho \omega^2} \{q\} \quad (3-283)$$

This equation can also be solved by the method of iteration, and the eigenvalues will approach the eigenvalues of Equation 3-269 as the number of modes considered approaches the number of degrees-of-freedom used in Equation 3-269. Figure 40 illustrates this for the case where 25 collocation points are used in Equation 3-269. In the modal case, the number of degrees-of-freedom is equal to 2 plus the number of elastic modes.

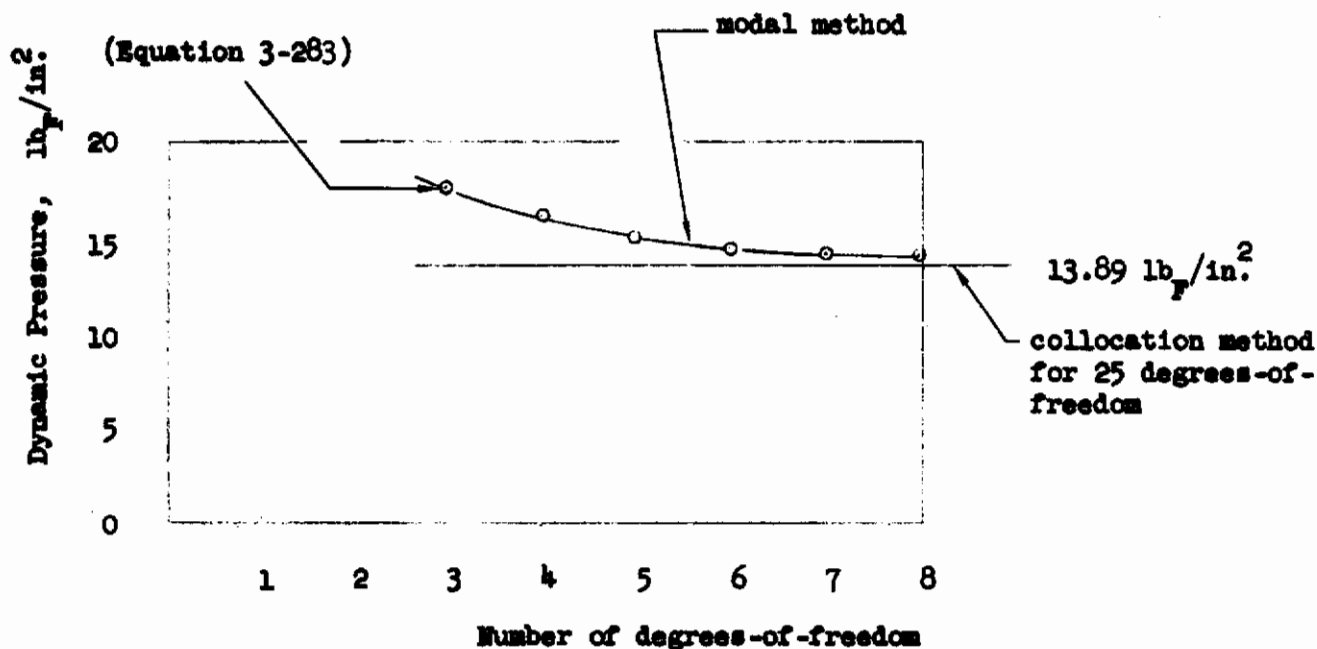

FIGURE 40 DYNAMIC PRESSURE OF DIVERGENCE AS A FUNCTION OF THE NUMBER OF MODES CONSIDERED - CASE OF RECTILINEAR FLIGHT

As a matter of practical computation, Equation 3-283 can be expressed as,

$$-\Gamma \lambda \left([C_{\dot{q}\dot{q}}^R] - \frac{1}{C_{\theta\theta}^R} \{C_{\dot{q}\theta}^R\} \{C_{\theta\dot{q}}^R\}' \right) \{q\} = \frac{\lambda}{\rho b V_\infty^2} \{q\} \tag{3-284}$$

where the C^R 's are elements from the matrix

$$\begin{bmatrix} \{\dot{x}\}' \\ \{\ddot{x}-x\}' \\ \{\psi\}' \end{bmatrix} [\Lambda] [\Delta] \begin{bmatrix} \{\dot{x}\} \\ \{\ddot{x}-x\} \\ \{\psi\} \end{bmatrix} = \begin{bmatrix} 0 & C_{\dot{x}\theta}^R & \{C_{\dot{x}\dot{q}}^R\}' \\ 0 & C_{\theta\theta}^R & \{C_{\theta\dot{q}}^R\}' \\ \{0\} & \{C_{\dot{q}\theta}^R\} & [C_{\dot{q}\dot{q}}^R] \end{bmatrix} \tag{3-285}$$

Contrails

Also, from Equation 3-284 we may derive the following approximate formula based on using only one mode:

$$\frac{1}{2} \rho v_0^2 = \frac{1}{\lambda} \frac{1}{\frac{C_{q\theta}^R C_{\theta q}^R}{C_{\theta\theta}^R} - C_{q\theta}^R} \quad (3-286)$$

$C_{\theta\theta}^R \equiv -C_{M_{\dot{\theta}}}$

For preliminary design purposes, these terms can be calculated from

$$C_{\theta\theta}^R = - \int_0^L \frac{\partial C_L}{\partial \alpha} (\bar{x}-x) dx \quad (3-287)$$

$$C_{\theta q}^R = \int_0^L (\bar{x}-x) \frac{\partial C_L}{\partial \alpha} \frac{dq}{dx} dx \quad (3-288)$$

$$C_{q\theta}^R = - \int_0^L q(x) \frac{\partial C_L}{\partial \alpha} dx \quad (3-289)$$

$$C_{qq}^R = \int_0^L q(x) \frac{\partial C_L}{\partial \alpha} \frac{dq}{dx} dx \quad (3-290)$$

$$\lambda = \frac{1}{\int_0^L EI(x) \frac{d^4 y}{dx^4} dx} \quad (3-291)$$

Contrails

with $\phi(x)$ normalized so that

$$\int_0^L m(x) \phi^2(x) dx = 1 \quad (3-292)$$

These formulas are fairly useful even when the shape of the first mode, $\phi(x)$, is assumed. If an assumed mode is used, it should satisfy the "rigid-body" orthogonality conditions:

$$\int_0^L m(x) \phi'(x) dx = 0 \quad (3-293)$$

$$\int_0^L (x-x_0) m(x) \phi(x) dx = 0 \quad (3-294)$$

The approximate formula, Equation 3-286, should be used with caution since Figure 40 shows the one-mode formula (three degrees-of-freedom) to give results on the unconservative side. For example, the one-mode formula gives

$$\frac{1}{2} \rho_a V a^2 = 17.428 \text{ lb/in}^2 \quad (3-295)$$

whereas the "exact" collocation method gives

$$\frac{1}{2} \rho_a V a^2 = 13.886 \text{ lb/in}^2 \quad (3-296)$$

The actual shape of the missile in the divergence mode may be calculated from the eigenvector in Equation 3-284 by using Equation 3-271 with

$$\zeta = 0 \quad (3-297)$$

and

$$\varepsilon = -\frac{1}{C_{\infty}^2} \{C_{\theta q}^2\} \{i q\} \quad (3-298)$$

(See Equation 3-280)

so that

$$\{p\} = \left([\varphi] - \frac{1}{C_{R_{00}}} \{x-x\} [C_{0q}^R] \right) \{q\} \quad (3-299)$$

Using this relation along with the eigenvector obtained by iteration of Equation 3-284, the result shown by Figure 41 was obtained.

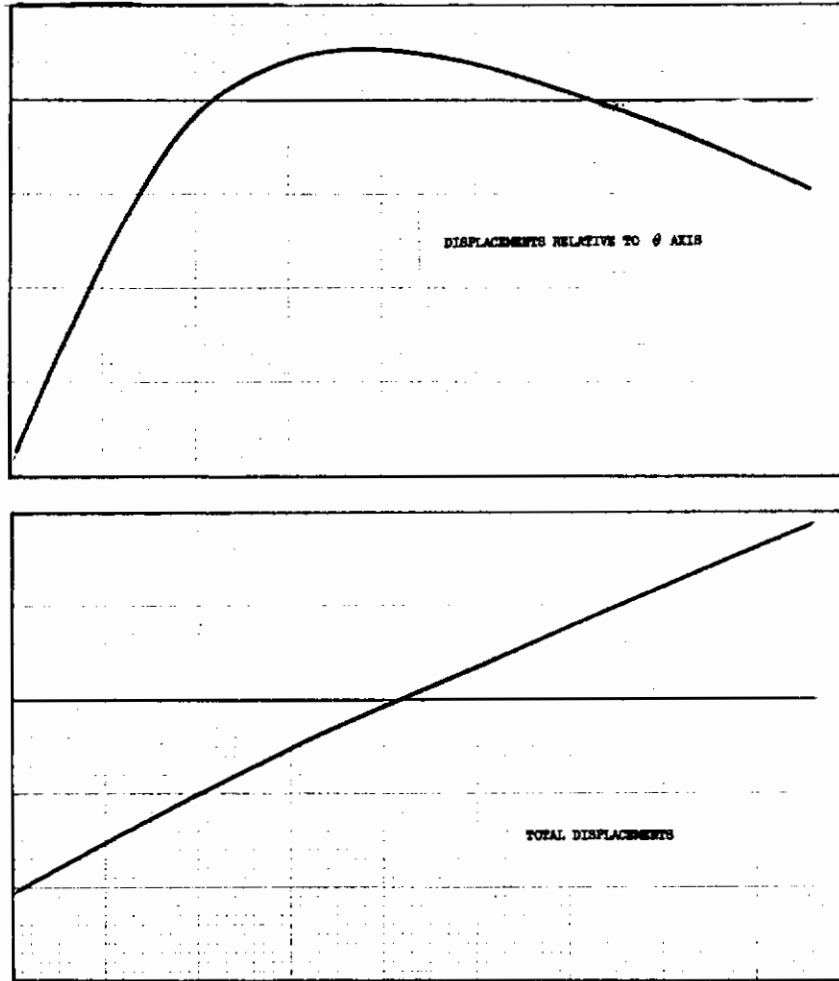

FIGURE 41 SHAPE OF THE MISSILE IN THE DIVERGENCE MODE - RECTILINEAR FLIGHT CASE

3.1.3.1.2 Divergence for the Vehicle in Steady Flight in a Circular Path¹

We have noted that it is impossible for an uncontrolled vehicle to be completely stable, in the strictest sense, when perturbed from a straight line path. It is possible, however, that the missile can achieve a configuration of stable equilibrium when the center of mass follows a trajectory which is a circle of radius, say, R.

¹The collocation method of analysis in this section is due principally to Vernon L. Alley, Jr., of the NASA Langley Research Center.

3.1.3.1.2.1 Collocation Method

The complete dynamic equations of motion are given by Equation 3-230. If we introduce the definition,

$$\{F\} = [K]\{p\} \quad (3-300)$$

then we can write Equation 3-230 as

$$\{F\} = -[A]\{\ddot{p}\} - \frac{1}{2} \rho_{\infty} V_{\infty}^2 [A][\Delta]\{p\} - \frac{\rho_{\infty} V_{\infty}^2}{2} [A]\{\dot{p}\} \quad (3-301)$$

If

$$\{1\}'\{F\} = 0 \quad (3-302)$$

and

$$\{\bar{x} - x\}'\{F\} = 0 \quad (3-303)$$

then we can write Equation 3-300 as

$$\{p\} = \{1\} \gamma + \{\bar{x} - x\} \theta + [P][E]\{F\} \quad (3-304)$$

(This follows the same line of reasoning as the procedure in Paragraph 3.1.3.1.1.1.)

We can satisfy both Equations 3-302 and 3-303 by assuming that the trajectory of the center of mass is a circle of radius, R; and that the motion is otherwise steady; and, in particular, $\dot{\theta} = 0$. These assumptions imply

$$\ddot{\gamma} = \frac{V_{\infty}^2}{R} \quad (3-305)$$

$$\dot{\theta} = \frac{V_{\infty}}{R} \quad (3-306)$$

Contraails

If we integrate these equations, we obtain

$$J(t) = \frac{v_{\omega}^2}{2R} t^2 + \dot{J}(0)t + J(0) \quad (3-307)$$

$$\theta(t) = \frac{v_{\omega}}{R} t + \theta(0) \quad (3-308)$$

Further, we note that the "rigid-body" angle-of-attack, α , is given by

$$\begin{aligned} \alpha &= \frac{\dot{J}(t)}{v_{\omega}} - \theta(t) \\ &= \frac{v_{\omega} t}{R} + \frac{\dot{J}(0)}{R} - \frac{v_{\omega} t}{R} - \theta(0) \\ &= \frac{\dot{J}(0)}{R} - \theta(0) \end{aligned} \quad (3-309)$$

= a constant

With no essential loss in generality, we assume

$$\dot{J}(0) = J'(0) = 0 \quad (3-310)$$

so that

$$\theta(0) = -\alpha \quad (3-311)$$

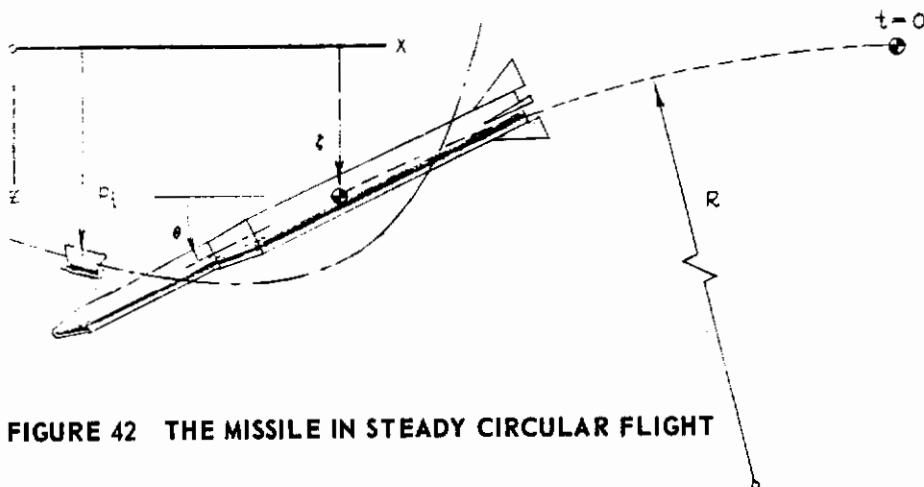

FIGURE 42 THE MISSILE IN STEADY CIRCULAR FLIGHT

Contrails

The trajectory of the collocation points is given by

$$p_i(t) = p_i(0) + \frac{v_0^2}{2R} t^2 + (\bar{x} - x_i) \frac{v_0}{R} t \quad (3-312)$$

or

$$\{p(t)\} = \{p(0)\} + \{1\} \frac{v_0^2}{2R} t^2 + \{\bar{x} - x\} \frac{v_0}{R} t \quad (3-313)$$

where

$$\{p(0)\} = -\{\bar{x} - x\} \alpha + [\Gamma]'[E]\{F\} \quad (3-314)$$

Under these assumptions, we have

$$\{\ddot{p}\} = \{1\} \frac{v_0^2}{R} \quad (3-315)$$

$$\begin{aligned} \{\alpha\} &= [\Delta]\{\dot{p}\} + \frac{1}{v_0} \{\dot{p}\} \\ &= [\Delta][\Gamma]'[E]\{F\} - \{1\} \left(\frac{v_0}{R} t - \alpha \right) \\ &\quad + \{1\} \frac{v_0}{R} t + \{\bar{x} - x\} \frac{1}{R} \end{aligned} \quad (3-316)$$

or

$$\{\alpha\} = \{1\} \alpha + \{\bar{x} - x\} \frac{1}{R} + [\Delta][\Gamma]'[E]\{F\} \quad (3-317)$$

Substitution of Equations 3-315 and 3-317 into Equation 3-301, we obtain

$$\{F\} = -[A]\{1\} \frac{v_0^2}{R} - \frac{1}{2\rho_0 v_0^2} [\Lambda]\{1\} \alpha - \frac{1}{2\rho_0 v_0^2} [\Lambda]\{\bar{x} - x\} \frac{1}{R} - \frac{1}{2\rho_0 v_0^2} [\Lambda][\Delta][\Gamma]'[E]\{F\} \quad (3-318)$$

Contrails

or

$$\{F\} = -\frac{1}{2}\rho\omega^2 \left([A]\{f\} \frac{z}{\rho R} + [A]\{f\}\alpha + [A]\{\bar{x}-x\} \frac{1}{R} \right) - \frac{1}{2}\rho\omega^2 [A][\Delta][\Gamma]'[E]\{F\} \quad (3-319)$$

In this expression, for a given value of $\rho\omega$ (i.e., at a given altitude), the flight curvature and angle of attack can be chosen so that Equations 3-302 and 3-303 are satisfied. Premultiplying by $\{1\}'$ and $\{\bar{x}-x\}'$, we obtain

$$\{1\}'\{F\} = -\frac{1}{2}\rho\omega^2 \left(\frac{zM}{\rho R} + C_{L\beta} \frac{1}{R} + C_{L\alpha} \alpha \right) - \frac{1}{2}\rho\omega^2 \{1\}'[A][\Delta][\Gamma]'[E]\{F\} = 0 \quad (3-320)$$

$$\{\bar{x}-x\}'\{F\} = -\frac{1}{2}\rho\omega^2 \left(C_{M\beta} \frac{1}{R} + C_{M\alpha} \alpha \right) - \frac{1}{2}\rho\omega^2 \{\bar{x}-x\}'[A][\Delta][\Gamma]'[E]\{F\} = 0 \quad (3-321)$$

If we solve these equations for $1/R$ and α , we obtain

$$\begin{bmatrix} \alpha \\ \frac{1}{R} \end{bmatrix} = - \begin{bmatrix} C_{L\alpha} & \frac{zM}{\rho\omega} + C_{L\beta} \\ C_{M\alpha} & C_{M\beta} \end{bmatrix}^{-1} \begin{bmatrix} \{1\}' \\ \{\bar{x}-x\}' \end{bmatrix} [A][\Delta][\Gamma]'[E]\{F\} \quad (3-322)$$

Substitution back into Equation 3-319 gives

$$[z][A][\Delta][\Gamma]'[E]\{F\} = \frac{z}{\rho\omega^2} \{F\} \quad (3-323)$$

where

$$[z] = -[1] + [A]\{f\}, \quad [A]\{f\} \frac{z}{\rho\omega} + [A]\{\bar{x}-x\} \begin{bmatrix} C_{L\alpha} & \frac{zM}{\rho\omega} + C_{L\beta} \\ C_{M\alpha} & C_{M\beta} \end{bmatrix}^{-1} \begin{bmatrix} \{1\}' \\ \{\bar{x}-x\}' \end{bmatrix} \quad (3-324)$$

Equation 3-323 can be solved by the same procedure used for Equation 3-269 in the case of level flight. Curiously enough, the results for the two cases are not significantly different. This bears out the fact that the approximation of artificially constraining the true center of mass of the missile does not introduce serious error. Again, for data corresponding to the NASA Scout, Equation 3-323 gives

$$\frac{1}{2} \rho_0 v_0^2 = 13.986 \text{ lb}_F/\text{in}^2, \quad (3-325)$$

for the curved flight case; whereas, Equation 3-269, for the rectilinear flight case, gave

$$\frac{1}{2} \rho_0 v_0^2 = 13.886 \text{ lb}_F/\text{in}^2 \quad (3-326)$$

The curved flight case was calculated at an altitude corresponding to:

$$\rho_0 = 1.241 \times 10^{-5} \text{ lb}_M/\text{in}^3 \quad (3-327)$$

There is some danger in generalizing the conclusions drawn here for the Scout vehicle, since they are based solely on the evidence of numerical results. Also, the curved flight effects are relatively easy to incorporate, particularly when a modal method is used as explained in the next paragraph.

3.1.3.1.2.2 Modal Method

The complete modal equations of motion can be obtained by applying Lagrange's equations to Equations 3-272, 3-273, and 3-274 with the result that

$$M \ddot{J} + \frac{1}{2} \rho_0 v_0^2 \left(C_{L_N} \left(\frac{\dot{J}}{V_0} - \theta \right) + C_{L_\dot{\theta}} \frac{\dot{\theta}}{V_0} \right) + \frac{1}{2} \rho_0 v_0^2 \left(\{1\}' [\Lambda] [\psi] \{ \dot{q} \} + \frac{1}{V_0} \{1\}' [\Lambda] [\varphi] \{ \dot{q} \} \right) = 0 \quad (3-328)$$

$$I \ddot{\theta} + \frac{1}{2} \rho_0 v_0^2 \left(C_{M_N} \left(\frac{\dot{J}}{V_0} - \theta \right) + C_{M_\dot{\theta}} \frac{\dot{\theta}}{V_0} \right) + \frac{1}{2} \rho_0 v_0^2 \left(\{ \ddot{x} - \lambda \}' [\Lambda] [\psi] \{ \dot{q} \} + \frac{1}{V_0} \{ \ddot{x} - \lambda \}' [\Lambda] [\varphi] \{ \dot{q} \} \right) = 0 \quad (3-329)$$

Contrails

$$\ddot{q}_z + r'_{\lambda} \dot{q}_z + \frac{1}{2} \rho_0 v_w^2 \left([\varphi]'[\Lambda] \dot{q}_z \left(\frac{\dot{z}}{v_w} - \theta \right) + [\varphi]'[\Lambda] \{ \bar{x} - x \} \frac{\dot{\theta}}{v_w} \right) + \frac{1}{2} \rho_0 v_w^2 \left([\varphi]'[\Lambda][\psi] \dot{q}_z + \frac{1}{v_w} [\varphi]'[\Lambda][\psi] \dot{z} \right) \quad (3-330)$$

The circular flight conditions are

$$\ddot{r} = \frac{v_w^2}{R}, \text{ a constant} \quad (3-331)$$

$$\frac{\dot{r}}{v_w} = \frac{1}{R}, \text{ a constant} \quad (3-332)$$

$$\dot{q}_z = \dot{q}_z(0) = \text{a constant} \quad (3-333)$$

which implies, as before,

$$\frac{\dot{z}}{v_w} - \theta = \alpha, \text{ a constant} \quad (3-334)$$

$$\dot{q}_z = \dot{q}_z = \dot{z} \quad (3-335)$$

$$\ddot{\theta} = 0 \quad (3-336)$$

Introducing these equations into Equations 3-328, 3-329, and 3-330, we obtain

$$\frac{M v_w^2}{R} + \frac{\rho_0 v_w^2}{2} \left(C_{L\alpha} \alpha + C_{L\theta} \frac{1}{R} + \dot{z}'[\Lambda][\psi] \dot{q}_z \right) = 0 \quad (3-337)$$

$$\frac{\rho_0 v_w^2}{2} \left(C_{M\alpha} \alpha + C_{M\theta} \frac{1}{R} + \{ \bar{x} - x \}'[\Lambda][\psi] \dot{q}_z \right) = 0 \quad (3-338)$$

$$r'_{\lambda} \dot{q}_z + \frac{\rho_0 v_w^2}{2} \left([\varphi]'[\Lambda] \dot{z} \alpha + [\varphi]'[\Lambda] \{ \bar{x} - x \} \frac{1}{R} \right) = \dot{z} \quad (3-339)$$

Contrails

If we solve the lift and moment equations for α and l/R and substitute into the elastic equations, we obtain

$$-\tau_{\lambda} [\varphi]' / r_{\lambda} - [\Lambda] \begin{bmatrix} \xi_1 \\ \bar{x}-x \end{bmatrix} \begin{bmatrix} C_{\lambda} \frac{2M}{\rho b} + C_{\lambda}^I \\ C_{M\alpha} \end{bmatrix}^{-1} \begin{bmatrix} \xi_1 \\ \bar{x}-x \end{bmatrix} [\Lambda] \begin{bmatrix} \psi \\ \psi' \end{bmatrix} = \frac{2}{2\pi V_{\infty}^2} \begin{bmatrix} q \\ q' \end{bmatrix} \quad (3-340)$$

As a matter of practical computation, Equation 3-340 can be written as

$$-\tau_{\lambda} / [C_{q\theta}^R] - \begin{bmatrix} \xi_1 \\ \bar{x}-x \end{bmatrix} \begin{bmatrix} C_{\lambda}^I & C_{\lambda}^I \\ C_{\theta\lambda}^I & C_{\theta\theta}^I \end{bmatrix} \begin{bmatrix} C_{\lambda}^I & \frac{2M}{\rho b} + C_{\lambda}^I \\ C_{\theta\lambda}^I & C_{\theta\theta}^I \end{bmatrix}^{-1} \begin{bmatrix} \xi_1 \\ \bar{x}-x \end{bmatrix} \begin{bmatrix} C_{\lambda}^R \\ C_{\theta\lambda}^R \end{bmatrix} \begin{bmatrix} \psi \\ \psi' \end{bmatrix} = \frac{2}{2\pi V_{\infty}^2} \begin{bmatrix} q \\ q' \end{bmatrix} \quad (3-341)$$

where the C^R 's and C^I 's are elements from the matrices

$$\begin{bmatrix} \xi_1 \\ \bar{x}-x \\ [\varphi]' \end{bmatrix} [\Lambda] \begin{bmatrix} \xi_1 \\ \bar{x}-x \\ [\varphi] \end{bmatrix} = \begin{bmatrix} 0 & C_{\lambda\theta}^R & \xi_1 C_{\lambda q}^R \\ 0 & C_{\theta\theta}^R & \xi_1 C_{\theta q}^R \\ \xi_1 C_{\theta\lambda}^R & \xi_1 C_{\theta\theta}^R & C_{q\theta}^R \end{bmatrix} \quad (3-342)$$

$$\begin{bmatrix} \xi_1 \\ \bar{x}-x \\ [\varphi]' \end{bmatrix} [\Lambda] \begin{bmatrix} \xi_1 \\ \bar{x}-x \\ [\varphi] \end{bmatrix} = \begin{bmatrix} C_{\lambda\lambda}^I & C_{\lambda\theta}^I & \xi_1 C_{\lambda q}^I \\ C_{\theta\lambda}^I & C_{\theta\theta}^I & \xi_1 C_{\theta q}^I \\ \xi_1 C_{\lambda q}^I & \xi_1 C_{\theta q}^I & C_{q\theta}^I \end{bmatrix} \quad (3-343)$$

The results of the solution of Equation 3-341 and comparison with solution of Equation 3-323 are shown by Figure 43.

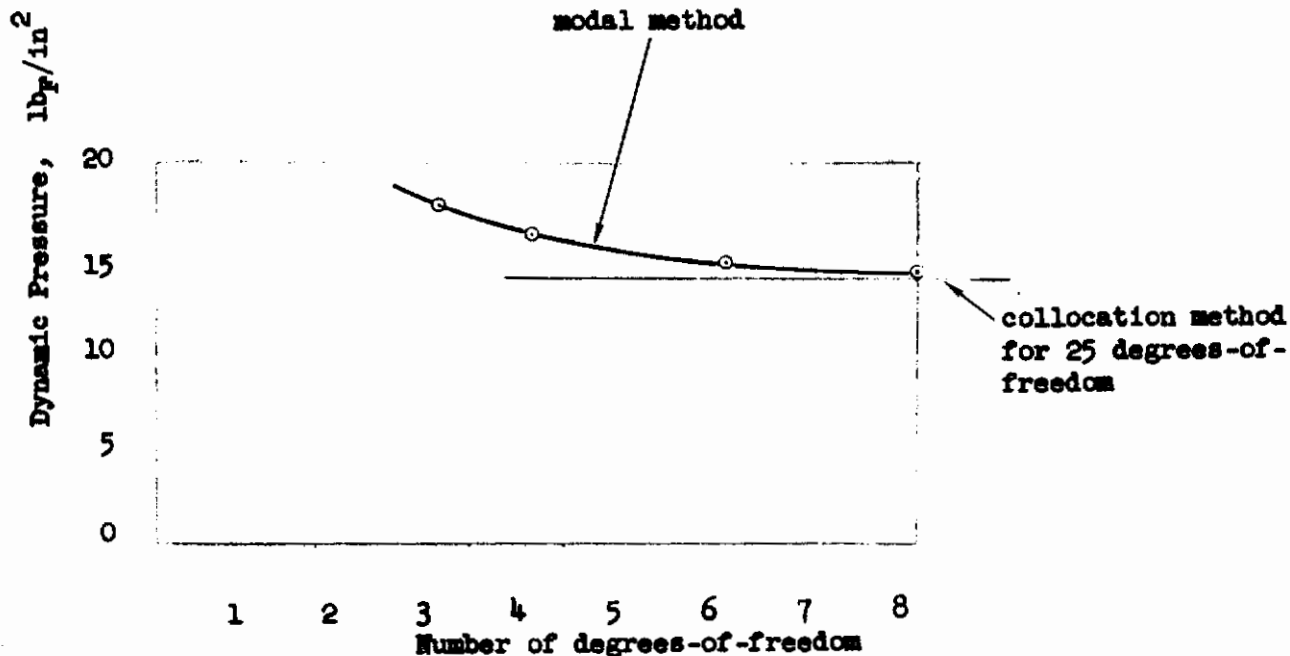

FIGURE 43 DYNAMIC PRESSURE OF DIVERGENCE AS A FUNCTION OF THE NUMBER OF MODES CONSIDERED - CIRCULAR FLIGHT CASE

To summarize the results of Paragraph 3.1.3.1, the following table is given

**TABLE 8
DYNAMIC PRESSURE OF DIVERGENCE**

	VEHICLE CONSTRAINED TO RECTILINEAR FLIGHT (lb _F /in ²)	VEHICLE IN CIRCULAR FLIGHT (lb _F /in ²)
MODAL METHOD		
one elastic mode	17.322977	17.428000
two elastic modes	15.744623	15.857967
five elastic modes	14.568644	14.673300
six elastic modes	14.157779	14.259390
COLLOCATION METHOD	13.886316	13.986051

3.1.3.2 Dynamic Stability with Locked Controls

In the dynamic case, we are interested in solving the equation (see Equation 3-232),

$$\left(s^2 [A] + s \frac{\omega_Y \omega}{2} [\Lambda] + [K] + \frac{\omega_Y \omega^2}{2} [\Lambda][\Delta] \right) \{\bar{p}\} = \{0\} \quad (3-344)$$

We want to prove, first, that this equation has a repeated zero root. To do this, let us transform to a complete set of normal coordinates by introducing the square modal matrix.

$$\{\bar{p}\} = [\{1\} \{x-x\} \{p\} \dots \{\phi\}_{n-2}] \{\bar{q}\} \quad (3-345)$$

or

$$\{\bar{p}\} = [\phi] \{\bar{q}\} \quad (3-346)$$

(The notation here departs slightly from Paragraphs 3.1.1 and 3.1.2 in that $[\phi]$ includes the rigid-body modes.) In Equation 3-346, $[\phi]$ is an $N \times N$ matrix of all the eigenvectors of the equation

$$\left(s^2 [A] + [K] \right) \{\varphi\} = \{0\} \quad (3-347)$$

If we substitute Equation 3-346 into Equation 3-344 and premultiply by $[\phi]'$, we obtain

$$\left(s^2 [M] + s \frac{\omega_Y \omega}{2} [C_I] + [F] + \frac{\omega_Y \omega^2}{2} [C_R] \right) \{\bar{q}\} = \{0\} \quad (3-348)$$

where

$$[\phi]' [A] [\phi] = [M] \quad (3-349)$$

$$[\phi]' [K] [\phi] = [F] \quad (3-350)$$

Contrails

$$[\varphi]'[\Lambda][\Delta][\varphi] = [C_R] \quad (3-351)$$

$$[\varphi]'[\Lambda][\varphi] = [C_I] \quad (3-352)$$

It can be shown that the roots to Equation 3-233 are invariant under this transformation, so that

$$\Delta(s, \frac{1}{2} \rho V_\infty^2) = |s^2 \Gamma_{MJ} + s \rho \frac{V_\infty}{2} [C_I] + \Gamma_{FJ} + \frac{\rho V_\infty^2}{2} [C_R]| = 0 \quad (3-353)$$

where, from previous results, we have

$$\Gamma_{MJ} = \begin{bmatrix} M & 0 & \{0\}' \\ 0 & I & \{0\}' \\ \{0\} & \{0\} & \Gamma_{1J} \end{bmatrix} \quad (3-354)$$

$$\Gamma_{FJ} = \begin{bmatrix} 0 & 0 & \{0\}' \\ 0 & 0 & \{0\}' \\ \{0\} & \{0\} & \Gamma_{\chi J} \end{bmatrix} \quad (3-355)$$

$$[C_R] = \begin{bmatrix} 0 & -C_{\alpha} & \{C_{\alpha q}^R\}' \\ 0 & -C_{\alpha} & \{C_{\alpha q}^R\}' \\ \{0\} & \{C_{\alpha q}^R\} & [C_{\alpha q}^R] \end{bmatrix} \quad (3-356)$$

$$[C_I] = \begin{bmatrix} C_{\alpha} & C_{L\alpha} & \{C_{\alpha q}^I\}' \\ C_{\alpha} & C_{M\alpha} & \{C_{\alpha q}^I\}' \\ \{C_{\alpha q}^I\} & \{C_{\alpha q}^I\} & [C_{\alpha q}^I] \end{bmatrix} \quad (3-357)$$

Contrails

Reference to Equations 3-116 and 3-117 will indicate that

$$\{C_{q\theta}^R\} = -\{C_{q\dot{\theta}}^I\} \quad (3-358)$$

a fact we will want to refer to presently. Equation 3-353 then has the form

$$\Delta(s, \frac{1}{2} \rho_{\infty} V_{\infty}^2) = \begin{vmatrix} Ms^2 + s \frac{\rho_{\infty} V_{\infty}}{2} C_{L\alpha} & s \frac{\rho_{\infty} V_{\infty}}{2} C_{L\dot{\theta}} - \frac{\rho_{\infty} V_{\infty}^2}{2} C_{L\alpha} & s \frac{\rho_{\infty} V_{\infty}}{2} \{C_{Y\dot{\theta}}^I\}' + \frac{\rho_{\infty} V_{\infty}^2}{2} \{C_{Y\dot{\theta}}^R\}' \\ s \frac{\rho_{\infty} V_{\infty}}{2} C_{M\alpha} & Is^2 + s \frac{\rho_{\infty} V_{\infty}}{2} C_{M\dot{\theta}} - \frac{\rho_{\infty} V_{\infty}^2}{2} C_{M\alpha} & s \frac{\rho_{\infty} V_{\infty}}{2} \{C_{\theta\dot{\theta}}^I\}' + \frac{\rho_{\infty} V_{\infty}^2}{2} \{C_{\theta\dot{\theta}}^R\}' \\ s \frac{\rho_{\infty} V_{\infty}}{2} \{C_{\dot{\theta}\dot{\theta}}^I\} & s \frac{\rho_{\infty} V_{\infty}}{2} \{C_{\dot{\theta}\dot{\theta}}^I\} + \frac{\rho_{\infty} V_{\infty}^2}{2} \{C_{\dot{\theta}\dot{\theta}}^R\} & [s^4 + \frac{1}{\lambda}] + s \frac{\rho_{\infty} V_{\infty}}{2} [C_{\dot{\theta}\dot{\theta}}^I] + \frac{\rho_{\infty} V_{\infty}^2}{2} [C_{\dot{\theta}\dot{\theta}}^R] \end{vmatrix} \quad (3-359)$$

Inspection will show that s appears as a common factor in the first column of this determinant. If we factor $s/\sqrt{V_{\infty}}$ out of the determinant and then add the first column to the second column and make note of Equation 3-358, we obtain

$$\Delta(s, \frac{1}{2} \rho_{\infty} V_{\infty}^2) = \frac{s}{V_{\infty}} \begin{vmatrix} V_{\infty} s M + \frac{\rho_{\infty} V_{\infty}^2}{2} C_{L\alpha} & s \frac{\rho_{\infty} V_{\infty}}{2} C_{L\dot{\theta}} + V_{\infty} s M & s \frac{\rho_{\infty} V_{\infty}}{2} \{C_{Y\dot{\theta}}^I\}' + \frac{\rho_{\infty} V_{\infty}^2}{2} \{C_{Y\dot{\theta}}^R\}' \\ \frac{\rho_{\infty} V_{\infty}^2}{2} C_{M\alpha} & Is^4 + s \frac{\rho_{\infty} V_{\infty}}{2} C_{M\dot{\theta}} & s \frac{\rho_{\infty} V_{\infty}}{2} \{C_{\theta\dot{\theta}}^I\}' + \frac{\rho_{\infty} V_{\infty}^2}{2} \{C_{\theta\dot{\theta}}^R\}' \\ \frac{\rho_{\infty} V_{\infty}^2}{2} \{C_{\dot{\theta}\dot{\theta}}^I\} & s \frac{\rho_{\infty} V_{\infty}}{2} \{C_{\dot{\theta}\dot{\theta}}^I\} & [s^4 + \frac{1}{\lambda}] + s \frac{\rho_{\infty} V_{\infty}}{2} [C_{\dot{\theta}\dot{\theta}}^I] + \frac{\rho_{\infty} V_{\infty}^2}{2} [C_{\dot{\theta}\dot{\theta}}^R] \end{vmatrix} \quad (3-360)$$

Inspection now shows that s is a common factor in the second column. Factoring out $s/\sqrt{V_{\infty}}$ again, we finally obtain

Contrails

$$\Delta(s, \frac{1}{2} \rho V_{\infty}^2) = \left(\frac{s}{V_{\infty}} \right)^2 \begin{vmatrix} V_{\infty} s M + \frac{\rho V_{\infty}^2}{2} C_{L\alpha} & V_{\infty}^2 M + \frac{\rho V_{\infty}^2}{2} C_{L\dot{\theta}} & s \frac{\rho V_{\infty}^2}{2} \{C_{Y\beta}^I\}' + \frac{\rho V_{\infty}^2}{2} \{C_{Y\beta}^R\}' \\ \frac{\rho V_{\infty}^2}{2} C_{M\alpha} & I s V_{\infty} + \frac{\rho V_{\infty}^2}{2} C_{N\dot{\theta}} & s \frac{\rho V_{\infty}^2}{2} \{C_{\sigma\beta}^I\}' + \frac{\rho V_{\infty}^2}{2} \{C_{\sigma\beta}^R\}' \\ \frac{\rho V_{\infty}^2}{2} \{C_{Y\beta}^I\} & \frac{\rho V_{\infty}^2}{2} \{C_{\sigma\beta}^I\} & [s^2 + \lambda] + s \frac{\rho V_{\infty}^2}{2} [C_{Y\beta}^I] + \frac{\rho V_{\infty}^2}{2} [C_{Y\beta}^R] \end{vmatrix} \quad (3-361)$$

The remaining determinant is still a polynomial in s , now of order $2N-2$. We have then shown that there is, in general, a repeated zero root to the dynamic stability determinant. The remaining polynomial governs the short period and elastic roots. In the case of the rigid missile, we have

$$\frac{\Delta(s, \frac{1}{2} \rho V_{\infty}^2)}{\left(\frac{s}{V_{\infty}} \right)^2} = \begin{vmatrix} M V_{\infty} s + \frac{\rho V_{\infty}^2}{2} C_{L\alpha} & M V_{\infty}^2 + \frac{\rho V_{\infty}^2}{2} C_{L\dot{\theta}} \\ \frac{\rho V_{\infty}^2}{2} C_{M\alpha} & I V_{\infty} s + \frac{\rho V_{\infty}^2}{2} C_{M\dot{\theta}} \end{vmatrix} = 0 \quad (3-362)$$

which is nothing more than the conventional "short-period quadratic,"

$$\left(s + \frac{\rho V_{\infty}^2}{2M} C_{L\alpha} \right) \left(s + \frac{\rho V_{\infty}^2}{2I} C_{M\dot{\theta}} \right) - \frac{\rho V_{\infty}^2 C_{M\alpha}}{2I} \left(1 + \frac{\rho V_{\infty}^2}{2M} C_{L\dot{\theta}} \right) = 0 \quad (3-363)$$

In the case of the rigid missile, "static" stability (i.e., $s = 0$) is given by

$$C_{M\alpha} + \frac{\rho V_{\infty}^2}{2M} (C_{M\alpha} C_{L\dot{\theta}} - C_{L\alpha} C_{M\dot{\theta}}) = 0 \quad (3-364)$$

Contrails

The second term is usually small and the criterion for static stability of a rigid body is taken as

$$C_{M\alpha} < 0 \tag{3-365}$$

For the case of an elastic body, the natural generalization for the criteria of static stability is to take

$$\lim_{s \rightarrow 0} \Delta(s, \frac{1}{2}\rho\omega^2) = 0 \tag{3-366}$$

as an equation governing the dynamic pressure of marginal static stability. From Equation 3-361, this is the condition

$$\begin{vmatrix} C_{M\alpha} & \frac{2M}{\rho\alpha} + C_{M\dot{\theta}} & \{C_{\eta\beta}^R\}' \\ C_{M\alpha} & C_{M\dot{\theta}} & \{C_{\theta\theta}^R\}' \\ \{C_{\eta\beta}^I\} & \{C_{\theta\theta}^I\} & \frac{2}{\rho\omega^2} [\lambda] + [C_{\eta\beta}^R] \end{vmatrix} = 0 \tag{3-367}$$

The lowest dynamic pressure for which this determinant is zero is exactly the same as the dynamic pressure of divergence in the curved flight case considered in Paragraph 3.1.3.1.2. This is easily shown by observing that Equation 3-367 is the determinant of the matrix of coefficients in Equations 3-337, 3-338, and 3-339.

Using the above results, we may draw some general conclusions about the complete dynamic stability determinant,

$$\Delta(s, \frac{1}{2}\rho\omega^2) = |s^2[A] + s\frac{\rho\omega^2}{2}[L] + [K] + \frac{\rho\omega^2}{I}[L][\Delta]| = 0 \tag{3-368}$$

1. This is a 2Nth order polynomial in s with real coefficients having a repeated zero root for any dynamic pressure.

2. The remainder of the roots vary with dynamic pressure in such a way that at least one root passes into the unstable part of the "root-plane" at the dynamic pressure of circular-flight divergence.

It could be proved, although it seems fairly evident, that the root which passes into the unstable part of the plane is the "short-period root" for the flexible missile.

The results of solving the stability determinant for a parametric variation of the dynamic pressure is shown by Figure 44. These results were obtained using the modal approximation and solving Equation 3-353 (instead of Equation 3-368) expressed in terms of only six elastic modes. (This equation was first expanded into a polynomial and then solved by appropriate numerical techniques.)

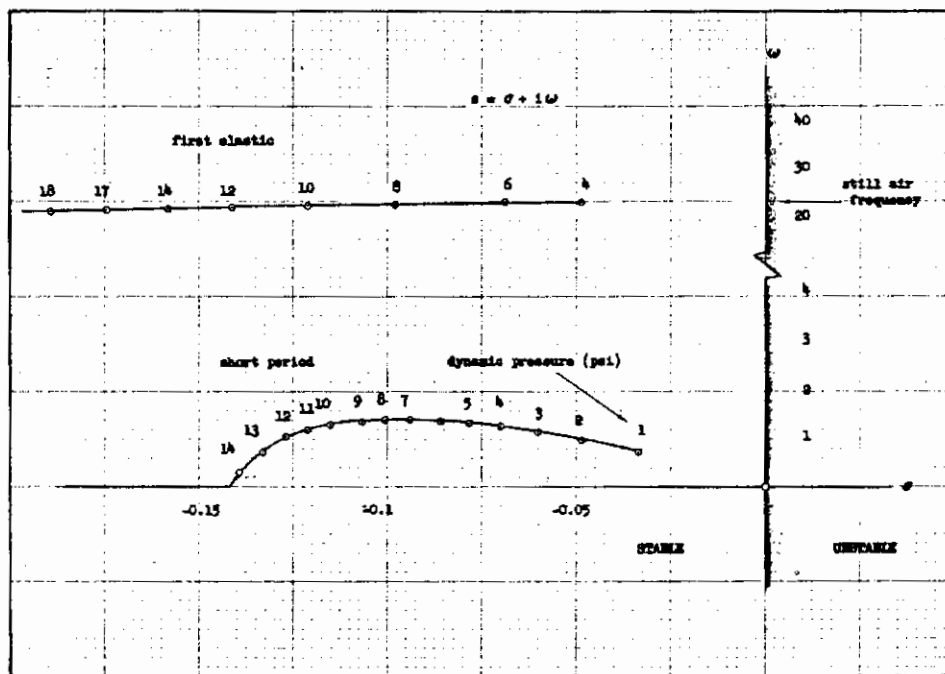

FIGURE 44 LOCUS OF MISSILE STABILITY ROOTS FOR VARYING DYNAMIC PRESSURE

The critical value of dynamic pressure is indicated better if the real and imaginary parts of the short period root are plotted versus the dynamic pressure as shown by Figure 45.

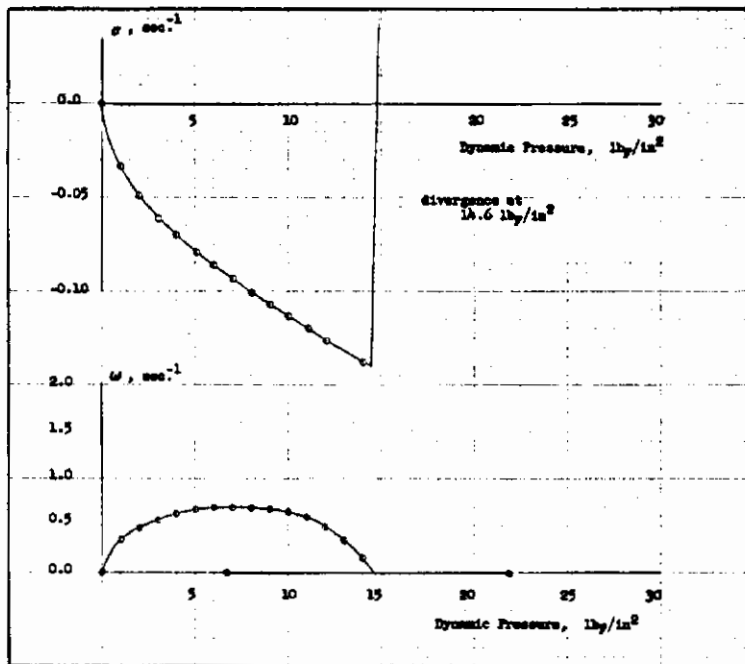

FIGURE 45 DAMPING AND FREQUENCY OF THE SHORT PERIOD MODE

The estimated point where $\sigma = 0$ in Figure 45 should agree with the six-elastic mode approximation for the circular-flight case. Reference to Table 8 gives

$$\frac{1}{2} \rho_{\infty} V_{\infty}^2 = 14.26 \text{ lb /in}^2 \quad (3-369)$$

while from Figure 45, we have

$$\frac{1}{2} \rho_{\infty} V_{\infty}^2 = 14.4 \text{ lb /in}^2 \quad (3-370)$$

The difference results from the error produced by expanding the determinant in Equation 3-353.

The stability roots may be determined more accurately by a method which does not require the expansion of a determinant. Also, in some applications, the eigenvectors, as well as the eigenvalues, are required.

Because the locked-control eigenvectors can be used in the analysis of a missile with active control, we want to consider, in the next paragraph, a method of solving the eigenvalue problem associated with Equation 3-353. We will consider then

$$\left(s^2 [M] + s \frac{\rho_{\infty} V_{\infty}^2}{2} [C_I] + [F] + \frac{\rho_{\infty} V_{\infty}^2}{2} [C_R] \right) \{ \bar{q} \} = \{ \bar{Q} \} \quad (3-371)$$

This problem is similar to that considered in Paragraph 2.2.3.5. In particular, Equation 3-371 should be compared with Equation 2-319. The only essential difference is that in Equation 3-371 the matrices are not all symmetric. We have already shown that there is a repeated zero root to this problem; it will be important to show that there is only one independent eigenvector corresponding to this zero root.

3.1.3.3 Solution of the Eigenvalue Problem for the Aeroelastic System

As in Paragraph 2.2.3.5, we will transform Equation 3-371 to a set of first-order equations. Consider the differential equations

$$[M] \ddot{\eta} + \frac{\rho a V_0}{2} [C_I] \dot{\eta} + \left([F] + \frac{\rho a V_0^2}{2} [C_R] \right) \eta = \{Q\} \quad (3-372)$$

Let us introduce

$$\{z\} = \dot{\eta} \quad (3-373)$$

Then we can write Equation 3-372 as

$$[M] \dot{z} + \frac{\rho a V_0}{2} [C_I] z + \left([F] + \frac{\rho a V_0^2}{2} [C_R] \right) \eta = \{Q\} \quad (3-374)$$

or

$$[V] \begin{Bmatrix} \dot{z} \\ \eta \end{Bmatrix} + [W] \begin{Bmatrix} z \\ \eta \end{Bmatrix} = \begin{Bmatrix} \{Q\} \\ \{0\} \end{Bmatrix} \quad (3-375)$$

where

$$[V] = \begin{bmatrix} [M] & [0] \\ [0] & [I_1] \end{bmatrix} \quad (3-376)$$

and

$$[W] = \begin{bmatrix} \frac{\rho a V_0}{2} [C_I] & [F] + \frac{\rho a V_0^2}{2} [C_R] \\ -[I_1] & [0] \end{bmatrix} \quad (3-377)$$

Contrails

The Laplace transform of the homogeneous equations is

$$(s[V] + [W]) \begin{Bmatrix} \{\dot{r}\} \\ \{\dot{q}\} \end{Bmatrix} = \{0\} \quad (3-378)$$

The stability determinant, $\Delta = 0$, in Equation 3-353 can also be written as

$$\Delta(s, \frac{1}{2}\rho\omega^2) = |s[V] + [W]| = 0 \quad (3-379)$$

which has $2N$ roots, two of which are zero. We will suppose that they are arranged in the following order

$$s = 0, 0, s_2, s_3, \dots, s_N, \bar{s}_2, \bar{s}_3, \dots, \bar{s}_N \quad (3-380)$$

where $s_i, i = 2, 3, \dots, N$, are complex roots with the conjugate denoted by \bar{s}_i . The eigenvectors corresponding to these roots are defined by

$$(s_i[V] + [W]) \{\dot{\varphi}\}_i = \{0\} \quad (3-381)$$

$$(s_i[V] + [W]') \{\dot{\gamma}\}_i = \{0\} \quad (3-382)$$

$$i = 2, 3, \dots, N$$

Corresponding to the zero root, we have

$$[W] \{\dot{\varphi}\}_0 = \{0\} \quad (3-383)$$

$$[W]' \{\dot{\gamma}\}_0 = \{0\} \quad (3-384)$$

It can be shown that $[W]$ is only simply degenerate¹ provided $\frac{1}{2}\rho\omega^2 \neq$ the divergence dynamic pressure. Thus, there is only one independent eigenvector corresponding to the repeated zero root. We can, however, introduce a pseudo zero-root eigenvector defined by

¹See Frazer, Duncan, and Collar, Elementary Matrices, Cambridge Univ. Press, 1950, for a definition of simple degeneracy.

Contrails

$$[W]\{\varphi^*\}_i = \{\varphi^*\}_0 \quad (3-385)$$

$$[W]'\{\eta^*\}_i = \{\eta^*\}_0 \quad (3-386)$$

The following orthogonality conditions can be derived from Equations 3-381, 3-382, 3-383, 3-384, 3-385, and 3-386.

$$\{\eta^*\}'_i [V]\{\varphi^*\}_j = 0 \quad (3-387)$$

$$\{\eta^*\}'_i [W]\{\varphi^*\}_j = 0 \quad (3-388)$$

for $i = j$ $i = 2, 3 \dots N$
 $j = 2, 3 \dots N$

$$\{\eta^*\}'_0 [W]\{\varphi^*\}_0 = 0 \quad (3-389)$$

$$\{\eta^*\}'_1 [W]\{\varphi^*\}_0 = 0 \quad (3-390)$$

$$\{\varphi^*\}'_0 [W]'\{\eta^*\}_0 = 0 \quad (3-391)$$

$$\{\varphi^*\}'_1 [W]'\{\eta^*\}_0 = 0 \quad (3-392)$$

We shall also show, below, that, in this problem

$$\{\eta^*\}'_0 [V]\{\varphi^*\}_0 = 0 \quad (3-393)$$

The eigenvectors of the original second-order system are

$$\left(s_i^2 [M] + s_i \frac{\omega \nu \omega}{2} [C_I] + [F] + \frac{\omega \nu \omega^2}{2} [C_R] \right) \{\varphi\}_i = \{0\} \quad (3-394)$$

$$\left(s_i^2 [M] + s_i \frac{\omega \nu \omega}{2} [C_I]' + [F] + \frac{\omega \nu \omega^2}{2} [C_R]' \right) \{\eta\}_i = \{0\} \quad (3-395)$$

Contrails

$$([F] + \frac{\rho_0 \gamma_0^2}{2} [C_R]) \{\varphi\}_0 = \{0\} \quad (3-396)$$

$$([F] + \frac{\rho_0 \gamma_0^2}{2} [C_R']) \{\gamma\}_0 = \{0\} \quad (3-397)$$

Comparison of these equations with Equations 3-381, 3-382, 3-383, and 3-384, using Equations 3-376 and 3-377, will give the following relation between the eigenvectors of the two systems of equations.

$$\{\varphi^*\}_i = \begin{bmatrix} s_i \{\varphi\}_i \\ \{\varphi\}_i \end{bmatrix} \quad (3-398)$$

$$\{\gamma^*\}_i = \begin{bmatrix} \{\gamma\}_i \\ \frac{1}{s_i} ([F] + \frac{\rho_0 \gamma_0^2}{2} [C_R']) \{\gamma\}_i \end{bmatrix} \quad (3-399)$$

for $i = 2, 3, \dots, N$

$$\{\varphi^*\}_0 = \begin{bmatrix} \{0\} \\ \{\varphi\}_0 \end{bmatrix} \quad (3-400)$$

Contrails

and

$$\{y^*\}_0 = \begin{bmatrix} \{y\}_0 \\ \frac{\rho_0 V_0}{\lambda} [C_I] \{y\}_0 \end{bmatrix} \quad (3-401)$$

If we introduce pseudo eigenvectors for the original system, defined by

$$([F] + \frac{\rho_0 V_0^2}{2} [C_R]) \{\varphi\}_1 = \frac{\rho_0 V_0}{2} [C_I] \{\varphi\}_0 \quad (3-402)$$

$$([F] + \frac{\rho_0 V_0^2}{2} [C_R])' \{y\}_1 = \frac{\rho_0 V_0}{2} [C_I]' \{y\}_0 \quad (3-403)$$

then we can relate these to the pseudo eigenvectors defined in Equations 3-385 and 3-386.

$$\{\varphi^*\}_1 = \begin{bmatrix} -\{\varphi\}_0 \\ \{\varphi\}_1 \end{bmatrix} \quad (3-404)$$

$$\{y^*\}_1 = \begin{bmatrix} \{y\}_1 \\ \frac{\rho_0 V_0}{2} [C_I]' \{y\}_1 - \{y\}_0 \end{bmatrix} \quad (3-405)$$

Contrails

We are then in a position to show that Equation 3-393 is true. From Equations 3-400, 3-401, and 3-376, we have

$$i\gamma'_0 [V] \{\varphi\}_0 = [i\gamma'_0] \frac{\rho\omega^2}{2} \{\gamma\}'_0 [C_I] \begin{bmatrix} [M] \{0\} \\ \{\varphi\}_0 \end{bmatrix} = \frac{\rho\omega^2}{2} \{\gamma\}'_0 [C_I] \{\varphi\}_0 \quad (3-406)$$

but from Equation 3-402,

$$\begin{aligned} \frac{\rho\omega^2}{2} \{\gamma\}'_0 [C_I] \{\varphi\}_0 &= \{\gamma_0\}' / ([F] + \frac{\rho\omega^2}{2} [C_R]) \{\varphi\}_1 \\ &= \{\varphi\}'_1 ([F] + \frac{\rho\omega^2}{2} [C_R]) \{\gamma\}_0 \\ &= 0 \end{aligned} \quad (3-407)$$

because of Equation 3-397.

Let us consider the nonhomogeneous equations,

$$({}^s[V] + [W]) \begin{bmatrix} \{\bar{\pi}\} \\ \{\bar{q}\} \end{bmatrix} = \begin{bmatrix} \{\bar{Q}\} \\ \{0\} \end{bmatrix} \quad (3-408)$$

and make the following transformation of coordinates

$$\begin{bmatrix} \{\bar{\pi}\} \\ \{\bar{q}\} \end{bmatrix} = [\varphi^*] \{\bar{q}^*\} \quad (3-409)$$

Contrails

where

$$[\varphi^*] = [\{\varphi^*\}_0 \ \{\varphi^*\}_1 \ \{\varphi^*\}_2 \dots \{\varphi^*\}_m \ \{\bar{\varphi}^*\}_2 \dots \{\bar{\varphi}^*\}_m] \quad (3-410)$$

and then premultiply the equations by

$$[\eta^*] = [\{\eta^*\}_1 \ \{\eta^*\}_0 \ \{\eta^*\}_2 \dots \{\eta^*\}_m \ \{\bar{\eta}^*\}_2 \dots \{\bar{\eta}^*\}_m] \quad (3-411)$$

We then obtain

$$(\{ \eta^* \}' [V] [\varphi^*] + \{ \eta^* \}' [W] [\varphi^*]) \{\bar{\eta}^*\} = \{ \eta^* \}' \begin{bmatrix} \{\bar{a}\} \\ \{0\} \end{bmatrix} \quad (3-412)$$

From the orthogonality conditions, we have

$$\{ \eta^* \}' [W] [\varphi^*] = \begin{bmatrix} \{\eta^*\}'_1 [W] \{\varphi^*\}_0 & \{\eta^*\}'_1 [W] \{\varphi^*\}_1 & & \\ \{\eta^*\}'_0 [W] \{\varphi^*\}_0 & \{\eta^*\}'_0 [W] \{\varphi^*\}_1 & & \\ & & \ddots & \\ & & & \{\eta^*\}'_i [W] \{\varphi^*\}_i & & \\ & & & & & \ddots \end{bmatrix} \quad (3-413)$$

$$\{ \eta^* \}' [V] [\varphi^*] = \begin{bmatrix} \{\eta^*\}'_1 [V] \{\varphi^*\}_0 & \{\eta^*\}'_1 [V] \{\varphi^*\}_1 & & \\ \{\eta^*\}'_0 [V] \{\varphi^*\}_0 & \{\eta^*\}'_0 [V] \{\varphi^*\}_1 & & \\ & & \ddots & \\ & & & \{\eta^*\}'_i [V] \{\varphi^*\}_i & & \\ & & & & & \ddots \end{bmatrix} \quad (3-414)$$

Contrails

and from Equation 3-381

$$s_i \{y^*_i\}' [V] \{\varphi^*_i\} + \{y^*_i\}' [W] \{\varphi^*_i\} = 0 \quad (3-415)$$

$$i = 2, 3, \dots, N$$

Now it is possible to choose $\{\eta^*_i\}$, such that Equation 3-386 is satisfied and at the same time

$$\{y^*_i\}' [V] \{\varphi^*_i\} = 0 \quad (3-416)$$

This is true because

$$\{y^*_i\}' + \mu \{y^*_i\}'_0 \quad (3-417)$$

satisfies Equation 3-386 for any value of μ , and μ can be chosen so that

$$(\{y^*_i\}' + \mu \{y^*_i\}'_0) [V] \{\varphi^*_i\} = 0 \quad (3-418)$$

Then

$$\{y^*_i\}' \rightarrow \{y^*_i\}' - \frac{\{y^*_i\}' [V] \{\varphi^*_i\}}{\{y^*_i\}'_0 [V] \{\varphi^*_i\}} \quad (3-419)$$

satisfies both Equation 3-386 and Equation 3-416. We note also that from Equations 3-376 and 3-400

$$[V] \{\varphi^*_i\}_0 = \{\varphi^*_i\}_0 \quad (3-420)$$

and hence, from Equation 3-385

$$\{y^*_i\}' [V] \{\varphi^*_i\}_0 = \{y^*_i\}'_0 \{\varphi^*_i\}_0 = \{y^*_i\}' [W] \{\varphi^*_i\} \quad (3-421)$$

We then have

$$s \{y^*\}' [V] \{\varphi^*\} + \{y^*\}' [W] \{\varphi^*\} = \begin{bmatrix} s \{y^*_1\}' [V] \{\varphi^*_1\}_0 & \{y^*_1\}' [V] \{\varphi^*_1\}_0 \\ 0 & s \{y^*_2\}'_0 [V] \{\varphi^*_2\}_1 \\ & \vdots \\ s \{y^*_i\}' [V] \{\varphi^*_i\}_i + \{y^*_i\}' [W] \{\varphi^*_i\}_i \\ & \vdots \end{bmatrix} \quad (3-422)$$

Contrails

If we normalize the eigenvectors so that

$$\{\eta^* \}'_0 [V] \{\varphi^* \}'_0 = 1 \quad (3-423)$$

$$\{\eta^* \}'_1 [V] \{\varphi^* \}'_1 = 1 \quad (3-424)$$

$$\{\eta^* \}'_i [V] \{\varphi^* \}'_i = 1 \quad (3-425)$$

$$i = 2, 3 \dots N$$

and use Equation 3-415, then

$$s [\eta^*]' [V] [\varphi^*] + [\eta^*]' [W] [\varphi^*] = \begin{bmatrix} s & & & \\ 0 & s & & \\ & & s-s_2 & \\ & & & \dots & \\ & & & & s-s_i & \\ & & & & & \dots & \\ & & & & & & s-s_N \end{bmatrix} \quad (3-426)$$

We then have, from Equation 3-412,

$$\begin{aligned} \{\bar{q}^* \}' &= (s [\eta^*]' [V] [\varphi^*] + [\eta^*]' [W] [\varphi^*])^{-1} [\eta^*]' \begin{bmatrix} \{\bar{q}\}' \\ \{0\}' \end{bmatrix} \\ &= \begin{bmatrix} \frac{1}{s} & & & & \\ & -\frac{1}{s_2} & & & \\ 0 & & \frac{1}{s} & & \\ & & & \frac{1}{s-s_2} & \\ & & & & \dots & \\ & & & & & \frac{1}{s-s_N} \\ & & & & & & \frac{1}{s-s_2} & \\ & & & & & & & \dots & \\ & & & & & & & & \frac{1}{s-s_N} \end{bmatrix} [\eta^*]' \begin{bmatrix} \{\bar{q}\}' \\ \{0\}' \end{bmatrix} \end{aligned} \quad (3-427)$$

Contrails

Substitution into Equation 3-409 gives

$$\begin{bmatrix} \{\bar{\pi}\} \\ \{\bar{q}\} \end{bmatrix} = [\phi^*] \begin{bmatrix} \frac{1}{s} & -\frac{1}{s_1} & & \\ 0 & \frac{1}{s} & & \\ & & \dots & \\ & & & \frac{1}{s-s_i} & \dots \end{bmatrix} [\eta^*] \begin{bmatrix} \{\bar{q}\} \\ \{0\} \end{bmatrix} \quad (3-428)$$

We can partition these equations, using the bottom half of $[\phi^*]$ and the top half of $[\eta^*]$ to obtain

$$\{\bar{q}\} = [\phi] \begin{bmatrix} \frac{1}{s} & -\frac{1}{s_1} & & \\ 0 & \frac{1}{s} & & \\ & & \dots & \\ & & & \frac{1}{s-s_i} & \dots \end{bmatrix} [\eta] \{\bar{q}\} \quad (3-429)$$

where, from Equations 3-398, 3-399, 3-400, 3-401, 3-404, and 3-405, we have

$$[\phi] = \{i\phi_0, i\phi_1, i\phi_2, \dots, i\phi_N, i\bar{q}_2, \dots, i\bar{q}_N\} \quad (3-430)$$

$$[\eta] = \{i\eta_1, i\eta_0, i\eta_2, \dots, i\eta_N, i\bar{\eta}_2, \dots, i\bar{\eta}_N\} \quad (3-431)$$

By expanding the indicated products, we have the following identity

$$\begin{bmatrix} [\phi] \begin{bmatrix} \frac{1}{s} & -\frac{1}{s_1} & & \\ 0 & \frac{1}{s} & & \\ & & \dots & \\ & & & \frac{1}{s-s_i} & \dots \end{bmatrix} [\eta]' \end{bmatrix} = \frac{1}{s} (i\phi_0 i\eta_1' + i\phi_1 i\eta_0') \\ - \frac{1}{s_1} i\phi_0 i\eta_1' \\ + \sum_{i=2}^N \left(\frac{i\phi_1 i\eta_i'}{s-s_i} + \frac{i\bar{q}_i i\bar{\eta}_i'}{s-s_i} \right) \quad (3-432)$$

In this expression we have

$$\sum_{i=2}^N \frac{\{\varphi\}_i \{\eta\}'_i}{s-s_i} + \frac{\{\bar{\varphi}\}_i \{\bar{\eta}\}'_i}{s-\bar{s}_i} = \sum_{i=2}^N \frac{(s-\bar{s}_i)\{\varphi\}_i \{\eta\}'_i + (s-s_i)\{\bar{\varphi}\}_i \{\bar{\eta}\}'_i}{(s-s_i)(s-\bar{s}_i)} \quad (3-433)$$

If we let

$$s = \tau_i + i\omega_i \quad (3-434)$$

$$[\psi_0]_i = -\{\varphi\}'_0 \{\eta\}'_0 \quad (3-435)$$

$$[\psi_1]_i = \{\varphi\}'_0 \{\eta\}'_1 + \{\varphi\}'_1 \{\eta\}'_0 \quad (3-436)$$

$$[\psi_0]_i = -2 \operatorname{Re} (\bar{s}_i \{\varphi\}'_i \{\eta\}'_i) \quad (3-437)$$

$$[\psi_1]_i = 2 \operatorname{Re} (\{\varphi\}'_i \{\eta\}'_i) \quad (3-438)$$

then

$$\{\bar{q}\}_s = \left(\frac{s[\psi_1]_1 + [\psi_0]_1}{s^2} + \sum_{i=2}^N \frac{s[\psi_1]_i + [\psi_0]_i}{s^2 - 2\tau_i s + \tau_i^2 + \omega_i^2} \right) \{\bar{q}\}_s \quad (3-439)$$

Comparing this with Equation 3-371, we must conclude that

$$\begin{aligned} & \left(s^2[M] + s \frac{1}{2} \omega \gamma \omega [C_I] + [F] + \frac{1}{2} \omega \gamma \omega^2 [C_R] \right)^{-1} \\ & = \frac{s[\psi_1]_i + [\psi_0]_i}{s^2} + \sum_{i=2}^N \frac{s[\psi_1]_i + [\psi_0]_i}{s^2 - 2\sigma_i s + \sigma_i^2 + \omega_i^2} \end{aligned} \quad (3-440)$$

The $[\psi]$ matrices in the above equation are all real matrices. We shall have occasion to use Equation 3-440 in the closed-loop stability analysis in the next section. Numerical methods for obtaining the eigenvectors are given in Appendix III of this report.

3.1.3.4 General "Point" Stability with Closed Control Loop

In the case where the control surface is active, the stability problem is far more involved than that considered in the previous section. When the control position is governed by information gained from sensors of the vehicle's attitude, the whole question of stability depends on the characteristics of the sensing elements and the power source for positioning the control mechanism. The equations governing the airframe, in this case, are given by Equation 3-106,

$$[M] \begin{bmatrix} \ddot{\gamma} \\ \ddot{\theta} \\ \ddot{q} \\ \ddot{\delta} \end{bmatrix} + [F] \begin{bmatrix} \dot{\gamma} \\ \dot{\theta} \\ \dot{q} \\ \dot{\delta} \end{bmatrix} + \frac{1}{2} \rho v \omega^2 \left([C_R] \begin{bmatrix} \dot{\gamma} \\ \dot{\theta} \\ \dot{q} \\ \dot{\delta} \end{bmatrix} + \frac{1}{v \omega} [C_I] \begin{bmatrix} \ddot{\gamma} \\ \ddot{\theta} \\ \ddot{q} \\ \ddot{\delta} \end{bmatrix} \right) = \begin{bmatrix} 0 \\ 0 \\ \{o\} \\ \Gamma \end{bmatrix} \quad (3-441)$$

where use has been made of Equations 3-122 through 3-125.

The derivation of these equations in Paragraph 3.1.2 was based on the use of an aerodynamic surface control. The general form of these equations, however, is valid for most other important cases. The particular aspects of gimballed engine control are considered in Paragraph 3.1.3.5.

The control moment, Γ , is derived from

$$\delta W = \delta \delta \Gamma \quad (3-442)$$

Contrails

which is the virtual work of the forces exerted on the control by the control servo-mechanism.

The Laplace transform of Equation 3-441 is

$$\left(s^2 [M] + [F] + \frac{1}{2} \rho_a V_0^2 [C_R] + \frac{s}{V_0} [C_I] \right) \begin{bmatrix} \bar{\delta} \\ \bar{\theta} \\ \bar{q} \\ \bar{p} \end{bmatrix} = \begin{bmatrix} 0 \\ 0 \\ \bar{q}_0 \\ \bar{p} \end{bmatrix} \quad (3-443)$$

If we partition Equation 3-443 into airframe equations and the single control equation, we have

$$\begin{bmatrix} [N_{11}(s)] & [N_{12}(s)] \\ [N_{21}(s)] & [N_{22}(s)] \end{bmatrix} \begin{bmatrix} \bar{q}_1(s) \\ \bar{q}_2(s) \end{bmatrix} = \begin{bmatrix} \bar{Q}_1(s) \\ \bar{Q}_2(s) \end{bmatrix} \quad (3-444)$$

where

$$\bar{q}_2(s) = \bar{p}(s), \quad \bar{Q}_2(s) = \bar{p}(s) \quad (3-445)$$

$$\bar{q}_1(s) = \begin{bmatrix} \bar{\delta} \\ \bar{\theta} \\ \bar{q} \\ \bar{p} \end{bmatrix}, \quad \bar{Q}_1(s) = \begin{bmatrix} 0 \\ 0 \\ \bar{q}_0 \\ \bar{p} \end{bmatrix} \quad (3-446)$$

and the coefficients are

$$[N_{11}(s)] = s^2 [M_{11}] + [F_{11}] + \frac{1}{2} \rho_a V_0^2 [C_{R_{11}}] + \frac{s}{V_0} [C_{I_{11}}] \quad (3-447)$$

$$[N_{12}(s)] = s^2 [M_{12}] + [F_{12}] + \frac{1}{2} \rho_a V_0^2 [C_{R_{12}}] + \frac{s}{V_0} [C_{I_{12}}] \quad (3-448)$$

Contrails

$$\{N_{21}(s)\} = s^{-1}\{M_{21}\} + \{F_{21}\} + \frac{1}{2}\rho_0 V_0^2 \{C_{R21}\} + \frac{s}{\omega} \{C_{I21}\} \quad (3-449)$$

$$N_{22}(s) = s^{-1}M_{22} + F_{22} + \frac{1}{2}\rho_0 V_0^2 (C_{R22} + \frac{s}{V_0} C_{I22}) \quad (3-450)$$

More explicitly, Equation 3-444 can be written as

$$\{N_{11}(s)\} \{ \bar{q}_1(s) \} + \{N_{12}(s)\} \bar{\theta}(s) = \{0\} \quad (3-451)$$

$$\{N_{21}(s)\}' \{ \bar{q}_1(s) \} + N_{22}(s) \bar{\theta}(s) = \bar{\Gamma}(s) \quad (3-452)$$

It may be noted that Equation 3-451 is expressed in terms of the locked-control coefficients considered in Paragraph 3.1.3.3. In fact, we may use the result of Equation 3-440 to write

$$[N_{11}(s)]^{-1} = \sum_{i=1}^N \frac{s [\psi_1]_i + [\psi_0]_i}{s^2 - 2\zeta_i s + \zeta_i^2 + \omega_i^2} \quad (3-453)$$

where the $[\psi]$'s are obtained from solving the locked control eigenvalue problem as described in Paragraph 3.1.3.3. This formulation of the problem makes it feasible to solve Equation 3-451 for the airframe coordinates,

$$\{ \bar{q}_1(s) \} = -[N_{11}(s)]^{-1} \{N_{12}(s)\} \bar{\theta}(s) \quad (3-454)$$

Substituting this into the control equation, we obtain

$$(N_{22}(s) - \{N_{21}(s)\}' [N_{11}(s)]^{-1} \{N_{12}(s)\}) \bar{\theta}(s) = \bar{\Gamma}(s) \quad (3-455)$$

Contrails

If we introduce the "aero-inertia impedance" of the control,

$$N(s) = N_{22}(s) - \{N_{21}(s)\}' [N_{11}(s)]^{-1} \{N_{12}(s)\} \quad (3-456)$$

then we can write Equation 3-455 as

$$N(s) \bar{\mathcal{F}}(s) = \bar{\Gamma}(s) \quad (3-457)$$

The moment from the control servo is usually governed by a mechanical or electrical signal which dictates a given control deflection, say, ϵ . Because of the impedance the control mechanism faces, the signal deflection, ϵ , is never equal to the actual control deflection, γ . A fairly general expression for the control moment developed is given by

$$\bar{\Gamma}(s) = -I(s) \left(\bar{\mathcal{F}}(s) - G(s) \bar{\epsilon}(s) \right) \quad (3-458)$$

where $I(s)$ and $G(s)$ can be given "empirical" definitions which may be used to measure them experimentally. The "power control impedance" can be defined by

$$I(s) = - \left(\frac{\bar{\Gamma}(s)}{\bar{\mathcal{F}}(s)} \right)_{\bar{\epsilon}(s)=0} \quad (3-459)$$

This is obtained experimentally by applying an oscillatory load on the control and measuring the response of the control with zero signal input to the servo. The "servo no-load impedance" can be defined by

$$G(s) = \left(\frac{\bar{\mathcal{F}}(s)}{\bar{\epsilon}(s)} \right)_{\bar{\Gamma}(s)=0} \quad (3-460)$$

which can be obtained from measurements of the response of the unloaded surface to oscillatory signals to the servo. In most cases, the control mechanism must be dismantled because its own inertia will load the servo at high frequencies.

Contrails

In many instances, theoretical expressions for $G(s)$ and $I(s)$ may be obtained from analysis of the servo¹. A useful approximation for preliminary analysis is the assumption

$$G(s) = 1 \quad (3-461)$$

Also, the power control impedance can usually be approximated by the impedance of an equivalent spring-damper system with undamped frequency, ω_p , and critical damping factor, ζ_p

$$I(s) = J\omega_p^2 + s J 2\zeta_p \omega_p \quad (3-462)$$

(J is the control hinge-line moment of inertia).

The complete control loop is closed when the signal to the servo, ϵ , is described in terms of the vehicle's attitude as seen by the gyros, and other sensing elements like angle-of-attack vanes and accelerometers. The sensing elements' estimate of the missile attitude can generally be expressed as

$$\{T(s)\} \begin{bmatrix} \{\xi(s)\} \\ \{\theta(s)\} \\ \{\bar{q}(s)\} \end{bmatrix} \quad (3-463)$$

For example, a single displacement gyro at a point $x = x_D$ on the missile would sense an attitude, θ_D , given by

$$\theta_D = -\frac{\partial \xi}{\partial x}(x_D, t)$$

Using the interpolation formula (see Equation 3-2), this can be expressed in terms of collocation point displacements

$$\frac{\partial \xi}{\partial x}(x_D, t) = \frac{1}{L} \{0 \ 1 \ 2\zeta_p \ 3\zeta_p^2\} [s] [T] \{\xi\} \quad (3-464)$$

where $x_{i-1} \leq x_D \leq x_i$

¹Expressions for $G(s)$ and $I(s)$ for an electrically energized hydraulic servo are given in Aeroelastic Analyses of Multi-Stage Rocket Systems, AGARD Report 390 July, 1961, equations A-65 and A-66.

Contrails

Substituting

$$\{p\} = \{1\} \dot{\theta} + \{\bar{x} - x\} \theta + [\varphi] \{q\} \quad (3-465)$$

we obtain

$$\begin{aligned} \theta_D = \frac{\partial p_x}{\partial x}(x_D, t) &= -\theta + \frac{1}{L} \{0, 2\dot{x}_D, 3\dot{x}_D^2\} \{s\} [\tau] [\varphi] \{q\} \\ &= \{0, -1, \frac{1}{L} \{0, 1, 2\dot{x}_D, 3\dot{x}_D^2\} \{s\} [\tau] [\varphi]\} \begin{bmatrix} \dot{\theta} \\ \theta \\ \{q\} \end{bmatrix} \end{aligned} \quad (3-466)$$

$$\bar{\theta}_D(s) = \{T(s)\}' \begin{bmatrix} \dot{\theta} \\ \theta \\ \{q\} \end{bmatrix} \quad (3-467)$$

Also, outputs from several displacement and/or rate gyros might be filtered and combined to arrive at an estimate of the vehicle attitude so that, in general, $T(s)$ in Equation 3-467 will depend upon the characteristics of all of the sensing elements and the shaping and filtering networks.

If $\mathcal{V}(t)$ is the required program of the vehicle's attitude, then the Laplace transform of the instantaneous attitude error is

$$\left(\{T(s)\}' \{ \bar{q}_i(s) \} - \bar{\mathcal{V}}(s) \right)$$

This error is monitored and used to command a control deflection, ϵ , according to some control law which, in a fairly general form, can be expressed as

$$\bar{\epsilon}(s) = K(s) \left(\{T(s)\}' \{ \bar{q}_i(s) \} - \bar{\mathcal{V}}(s) \right) \quad (3-468)$$

where $K(s)$ is a gain function with the units of radians of control deflection per unit radian of attitude error. An example, representative of a rigid missile with a perfect gyro is,

$$\bar{\epsilon}(s) = K_D \left(\bar{\theta}(s) - \bar{\mathcal{V}}(s) \right) \quad (3-469)$$

where K_D is a constant.

Contrails

Equation 3-454 can be used to write the sensed attitude as

$$\{T(s)\} \{ \bar{\theta}_1(s) \} = - \{T(s)\} \{N_{11}(s)\}^{-1} \{N_{12}(s)\} \bar{\theta}(s) = R(s) \bar{\theta}(s) \quad (3-470)$$

The function,

$$R(s) = - \{T(s)\} \{N_{11}(s)\}^{-1} \{N_{12}(s)\} \quad (3-471)$$

is usually termed the "airframe transfer function." It gives the sensed attitude of the missile in terms of control deflection. By way of summary, we have the following equations

$$N(s) \bar{\theta}(s) = \bar{\Gamma}(s) \quad (3-472)$$

$$\bar{\Gamma}(s) = -I(s) \{ \bar{\theta}(s) - G(s) \bar{e}(s) \} \quad (3-473)$$

$$\bar{e}(s) = K(s) \{ R(s) \bar{\theta}(s) - \bar{\Gamma}(s) \} \quad (3-474)$$

The only functions that depend on the aeroelastic parameters of the missile are $N(s)$ and $R(s)$, and these are both independent of the more important parameters involved in the design of the control system. $N(s)$ and $R(s)$ may be calculated in terms of polynomials in s by using Equation 3-453.

$$N(s) = \left(s^2 M_{22} + F_{22} + \frac{1}{2} \rho V a^2 (C_{R12} + \frac{s}{V a} C_{I22}) \right) - \left(s^2 \{M_{21}\}' + \{F_{21}\}' + \frac{1}{2} \rho V a^2 \left(\{C_{R21}\}' + \frac{s}{V a} \{C_{I21}\}' \right) \right) \left(\sum_{i=1}^N \frac{s [\psi_1]_i + [\omega_0]_i}{s^2 - 2\sigma_1 s + \sigma_1^2 + \omega_1^2} \right) \left(s^2 \{M_{12}\} + \{F_{12}\} + \frac{1}{2} \rho V a^2 \left(\{C_{R12}\} + \frac{s}{V a} \{C_{I12}\} \right) \right) \quad (3-475)$$

Controls

$$R(s) = - \{T(s)\} \left(\sum_{i=1}^N \frac{s [\psi_1]_i + [\psi_0]_i}{s^2 - 2\sigma_i s + \sigma_i^2 + \omega_i^2} \right) \left(s^2 \{M_{12}\} + \{F_{12}\} + \frac{1}{2} \rho_{\infty} V_{\infty}^2 \{C_{R_{12}}\} + \frac{s}{V_{\infty}} \{C_{I_{12}}\} \right) \quad (3-476)$$

If we eliminate $\bar{\gamma}$ and $\bar{\Gamma}$ in Equations 3-472 and 3-473, we find

$$\bar{\gamma}(s) = \frac{G(s)}{1 + \frac{N(s)}{I(s)}} \bar{e}(s) \quad (3-477)$$

Substituting this into Equation 3-474 gives

$$\bar{e}(s) = K(s)R(s) \left(\frac{G(s)}{1 + \frac{N(s)}{I(s)}} \right) \bar{e}(s) - K(s)\bar{\gamma}(s) \quad (3-478)$$

or

$$\left(\frac{K(s)G(s)R(s)I(s)}{I(s) + N(s)} - 1 \right) \bar{e}(s) = K(s)\bar{\gamma}(s) \quad (3-479)$$

The stability of the system is governed by the equation

$$\left(K(s)G(s)R(s) - \frac{N(s)}{I(s)} - 1 \right) = 0 \quad (3-480)$$

The three functions, $K(s)$, $G(s)$, and $I(s)$, associated with the control system can usually be written as rational functions of s (i.e., as the ratio of two polynomials in s). It is also clear from Equations 3-475 and 3-476 that the two functions, $N(s)$ and $R(s)$, associated with the aeroelastic system can be written as rational functions of s . It is then possible, by multiplying and adding polynomials coefficients, to express Equation 3-480 as a single polynomial equation which may be solved for the stability roots of the whole system. The principal advantage of this technique is that a characteristic polynomial may be developed which has important control system gains appearing explicitly so that they may be varied without having to reconsider the whole aeroelastic system.

Contrails

It is characteristic of mass-balanced, aerodynamically-balanced control surfaces that

$$\frac{N(s)}{I(s)} \rightarrow 0 \quad (3-481)$$

so that Equation 3-480, in this case, reduces to the equation

$$K(s)G(s)R(s) - 1 = 0 \quad (3-482)$$

This is far from the actual fact in the case of a gimbale engine, but for the aerodynamically controlled NASA Scout launch vehicle, it proves to be a valid approximation. The control equation

$$N(s)\bar{p} = \bar{r} = -I(s)(\bar{p} - G(s)\bar{e}) \quad (3-483)$$

in this case, reduces to

$$\bar{p} = G(s)\bar{e} \quad (3-484)$$

In subsequent sections, this approximation is referred to as the "perfect servo assumption."

3.1.3.5 Gimbale Engine Considerations in Closed Loop Stability

There are some important dynamic effects of gimbale, thrusting engines which have not been considered in the previous sections. The most important of these effects is the loss in control effectiveness due to engine inertia at high control frequencies. The particular frequency where the control force is zero is commonly called the "dog-wags-tail" frequency.

In the discussion below, we will assume the vehicle in a vacuum with no external forces other than the thrust and the control force from the actuator.

Let $p_z(x,t)$ be the continuous displacement of the missile

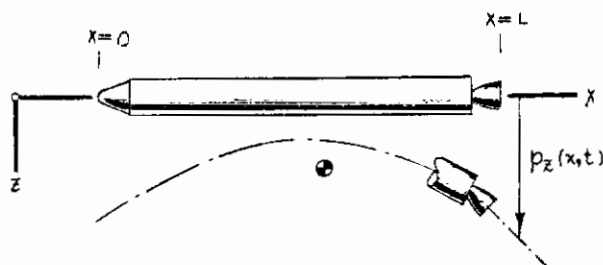

FIGURE 46 SLENDER LAUNCH VEHICLE WITH GIMBALED ENGINE

The total kinetic energy of the system is

$$T = \frac{1}{2} \int_0^L m(x) \left(\frac{\partial p_z}{\partial t} \right)^2 dx \quad (3-485)$$

and the total strain energy is

$$U = \frac{1}{2} \int_0^L EI(x) \left(\frac{\partial^2 p_z}{\partial x^2} \right)^2 dx + \frac{1}{2} \int_0^L N(x) \left(\frac{\partial p_z}{\partial x} \right)^2 dx \quad (3-486)$$

where the axial resultant, $N(x)$, is given by

$$N(x) = \int_0^x \left(T(x) - \frac{m(x)}{M} \int_0^L T(s) ds \right) dx \quad (3-487)$$

The virtual work of external forces is

$$\delta W = - \int_0^L \delta p_z \left(T(x) \frac{\partial p_z}{\partial x} \right) dx + \delta \theta \Gamma \quad (3-488)$$

Contrails

The gimbal angle γ is given by the jump in the slope at the gimbal,
 $x = x_C$

$$\gamma = \left(\frac{\partial p_z}{\partial x}\right)_{x=x_C^+} - \left(\frac{\partial p_z}{\partial x}\right)_{x=x_C^-} \quad (3-489)$$

We will suppose that the system can be approximated by one with a finite number of degrees-of-freedom as in the previous sections.

$$p_z(x,t) = \{h_z(x)\}' \{\dot{p}(t)\} \quad (3-490)$$

Expressed in terms of the generalized coordinates, \dot{p}_i , the kinetic energy is

$$\begin{aligned} T &= \frac{1}{2} \{\dot{p}\}' \int_0^L \{h_z(x)\}' \{h_z(x)\}' m(x) dx \{\dot{p}\} \\ &= \frac{1}{2} \{\dot{p}\}' [A] \{\dot{p}\} \end{aligned} \quad (3-491)$$

where

$$[A] = \int_0^L \{h_z(x)\}' \{h_z(x)\}' m(x) dx \quad (3-492)$$

The strain energy is

$$\begin{aligned} U &= \frac{1}{2} \{\dot{p}\}' \int_0^L EI(x) \left\{ \frac{d^2 h_z}{dx^2}(x) \right\}' \left\{ \frac{d^2 h_z}{dx^2}(x) \right\}' dx \{\dot{p}\} \\ &\quad + \frac{1}{2} \{\dot{p}\}' \int_0^L N(x) \left\{ \frac{dh_z}{dx}(x) \right\}' \left\{ \frac{dh_z}{dx}(x) \right\}' dx \{\dot{p}\} \\ &= \frac{1}{2} \{\dot{p}\}' [K] \{\dot{p}\} + \frac{1}{2} \{\dot{p}\}' [N] \{\dot{p}\} \end{aligned} \quad (3-493)$$

where

$$[K] = \int_0^L EI(x) \left\{ \frac{d^2 h_z}{dx^2}(x) \right\}' \left\{ \frac{d^2 h_z}{dx^2}(x) \right\}' dx \quad (3-494)$$

Contrails

$$[N] = \int_0^L N(x) \left\{ \frac{dh_z}{dx}(x) \right\} \left\{ \frac{dh_z}{dx}(x) \right\}' dx \quad (3-495)$$

Equation 3-489 becomes

$$\begin{aligned} \gamma &= \left\{ \frac{dh_z}{dx}(x_c^+) \right\}' \{p\} - \left\{ \frac{dh_z}{dx}(x_c^-) \right\}' \{p\} \\ &= \{\eta_p\}' \{p\} \end{aligned} \quad (3-496)$$

where

$$\{\eta_p\}' = \left\{ \frac{dh_z}{dx}(x_c^+) \right\}' - \left\{ \frac{dh_z}{dx}(x_c^-) \right\}' \quad (3-497)$$

If the control moment, Γ , from the servo is zero, the system has three zero-frequency modes. One is a translation mode defined by

$$p_z(x,t) = 1 = \{h_z(x)\}' \{\varphi_R\}_1 \quad (3-498)$$

(In the case the generalized coordinates are collocation point displacements, we have

$$\{\varphi_R\}_1 = \{1\}$$

A second rigid-body mode is defined by

$$p_z(x,t) = -x = \{h_z(x)\}' \{\varphi_R\}_2 \quad (3-499)$$

A third zero-frequency mode is given by

$$p_z(x,t) = \begin{cases} 0 & x < x_c \\ x - x_c & x \geq x_c \end{cases} = \{h_z(x)\}' \{\varphi_R\}_3 \quad (3-500)$$

which represents a unit deflection of the control.

Controls

An important simplification has resulted in previous sections because the rigid-body modes were mutually orthogonal. We can introduce a set of orthogonal rigid-body modes by taking

$$\{\varphi_r\} = \{\varphi_R\}_1 \quad (3-501)$$

and

$$\{\varphi_\theta\} = \{\varphi_R\}_2 + c \{\varphi_R\}_1 \quad (3-502)$$

such that

$$\{\varphi_r\}'[A]\{\varphi_\theta\} = 0 \quad (3-503)$$

This gives

$$c \{\varphi_R\}_1'[A]\{\varphi_R\}_1 + \{\varphi_R\}_1'[A]\{\varphi_R\}_2 = 0 \quad (3-504)$$

or

$$c = - \frac{\{\varphi_R\}_1'[A]\{\varphi_R\}_2}{\{\varphi_R\}_1'[A]\{\varphi_R\}_1} \quad (3-505)$$

$$\{\varphi_\theta\} = - \frac{\{\varphi_R\}_1'[A]\{\varphi_R\}_2}{\{\varphi_R\}_1'[A]\{\varphi_R\}_1} \{\varphi_R\}_1 + \{\varphi_R\}_2 \quad (3-506)$$

An orthogonal control mode is constructed in a similar fashion. Take

$$\{\varphi_p\} = \{\varphi_R\}_3 + c_1 \{\varphi_r\} + c_2 \{\varphi_\theta\} \quad (3-507)$$

and require

$$\{\varphi_p\}'[A]\{\varphi_p\} = 0 \quad (3-508)$$

$$\{\varphi_\theta\}'[A]\{\varphi_p\} = 0 \quad (3-509)$$

Contrails

This gives

$$\{\varphi_p\}'[A]H\varphi_p\} = \{\varphi_p\}'[A]H\varphi_R\}_3 + c_1 M = 0 \quad (3-510)$$

$$\{\varphi_0\}'[A]H\varphi_p\} = \{\varphi_0\}'[A]H\varphi_R\}_3 + c_2 I = 0 \quad (3-511)$$

where

$$M = \{\varphi_p\}'[A]H\varphi_p\} \quad (3-512)$$

$$I = \{\varphi_0\}'[A]H\varphi_0\} \quad (3-513)$$

We then have

$$c_1 = -\frac{1}{M} \{\varphi_p\}'[A]H\varphi_R\}_3 \quad (3-514)$$

$$c_2 = -\frac{1}{I} \{\varphi_0\}'[A]H\varphi_R\}_3 \quad (3-515)$$

Substitution into Equation 3-507 gives

$$\begin{aligned} \{\varphi_p\} &= \{\varphi_R\}_3 - \frac{1}{M} (\{\varphi_p\}'[A]H\varphi_R\}_3) \{\varphi_p\} \\ &\quad - \frac{1}{I} (\{\varphi_0\}'[A]H\varphi_R\}_3) \{\varphi_0\} \\ &= \left(I_1 - \frac{1}{M} \{\varphi_p\}'\{\varphi_p\}[A] - \frac{1}{I} \{\varphi_0\}'\{\varphi_0\}[A] \right) \{\varphi_R\}_3 \\ &= [C]'\{\varphi_R\}_3 \end{aligned} \quad (3-516)$$

Contrails

The virtual work of external forces is

$$\begin{aligned} \delta W &= -\{\delta p\}' \int_0^L \{h_z\} \tau(x) \left\{ \frac{dh_z}{dx} \right\}' dx \{p\} + \delta p \Gamma \\ &= -\{\delta p\}' [H] \{p\} + \delta p \Gamma \end{aligned} \quad (3-517)$$

where

$$[H] = \int_0^L \{h_z(x)\} \tau(x) \left\{ \frac{dh_z(x)}{dx} \right\}' dx \quad (3-518)$$

To derive the elastic modes, we impose the constraint $\gamma = 0$. From Lagrange's equations we obtain

$$[\Gamma]' [E] [\Gamma] [A] \{ \varphi \} = \lambda \{ \varphi \} \quad (3-519)$$

where $[E]$ is an influence matrix for the missile with locked controls and

$$[\Gamma] = \begin{bmatrix} 1 \\ -\frac{1}{M} \{ \varphi_s \} H \{ \varphi_s \}' \\ -\frac{1}{I} \{ \varphi_\theta \} H \{ \varphi_\theta \}' \end{bmatrix} \quad (3-520)$$

We then make the following transformation of coordinates

$$\{p\} = \{ \varphi_s \} \delta + \{ \varphi_\theta \} \theta + [\phi] \{q\} + \{ \varphi_p \} \nu \quad (3-521)$$

where $[\phi]$ is the matrix of locked-control elastic modes. By this transformation we obtain

$$\tau = \frac{1}{2} \begin{bmatrix} \dot{\delta} \\ \dot{\theta} \\ \dot{q} \\ \dot{\nu} \end{bmatrix} [M] \begin{bmatrix} \delta \\ \theta \\ q \\ \nu \end{bmatrix} \quad (3-522)$$

$$U = \frac{1}{2} [\delta \theta \ \{\delta q\}' \ \delta \varphi] [F] \begin{bmatrix} \delta \\ \theta \\ \{q\}' \\ \varphi \end{bmatrix} \quad (3-523)$$

$$\delta W = - [\delta \gamma \ \delta \theta \ \{\delta q\}' \ \delta \varphi] [U] \begin{bmatrix} \delta \\ \theta \\ \{q\}' \\ \varphi \end{bmatrix} + \delta \gamma \Gamma \quad (3-524)$$

where the axial load part of the strain energy has been included in [U]. In these expressions we have

$$[M] = \begin{bmatrix} M & 0 \\ 0 & I \\ & & \{1\} [\varphi]' [A] \{\varphi_p\}' \\ & & \{\varphi_p\}' [A] [\varphi] & J \end{bmatrix} \quad (3-525)$$

where

$$J = \{\varphi_p\}' [A] \{\varphi_p\} \quad (3-526)$$

$$[F] = \begin{bmatrix} 0 & 0 & & \\ 0 & 0 & & \\ & & \{k\} & \\ & & & 0 \end{bmatrix} \quad (3-527)$$

Contrails

$$\begin{aligned}
 [U] = & \begin{bmatrix} 0 & 0 & \{\dot{\phi}_0\}' & 0 \\ 0 & \{\phi_0\}'[N][\phi_0] & \{\phi_0\}'[N][\phi] & \{\phi_0\}'[N][\phi_p] \\ \{\dot{\phi}_0\}' & [\phi]'[N][\phi_0] & [\phi]'[N][\phi] & [\phi]'[N][\phi_p] \\ 0 & \{\phi_p\}'[N][\phi_0] & \{\phi_p\}'[N][\phi] & \{\phi_p\}'[N][\phi_p] \end{bmatrix} \\
 + & \begin{bmatrix} 0 & \{\phi_p\}'[H][\phi_0] & \{\phi_p\}'[H][\phi] & \{\phi_p\}'[H][\phi_p] \\ 0 & \{\phi_0\}'[H][\phi_0] & \{\phi_0\}'[H][\phi] & \{\phi_0\}'[H][\phi_p] \\ \{\dot{\phi}_0\}' & [\phi]'[H][\phi_0] & [\phi]'[H][\phi] & [\phi]'[H][\phi_p] \\ 0 & \{\phi_p\}'[H][\phi_0] & \{\phi_p\}'[H][\phi] & \{\phi_p\}'[H][\phi_p] \end{bmatrix}
 \end{aligned}$$

(3-528)

Now,

$$\begin{aligned}
 & \{\phi_0\}'[N][\phi_0] + \{\phi_0\}'[H][\phi_0] \\
 &= \int_0^L N(x) dx - \int_0^L (\bar{x}-x)T(x) dx \\
 &= \int_0^L N(x) dx - (\bar{x}-L) \int_0^L T(x) dx - \int_0^L \int_0^x T(s) ds dx \\
 &= - \int_0^L \int_0^x m(s) \frac{T}{M} ds dx - (\bar{x}-L)T \\
 &= - \frac{T}{M} (L-\bar{x})M - (\bar{x}-L)T \\
 &= 0
 \end{aligned}$$

(3-529)

Controls

From Lagrange's equations we obtain

$$M\ddot{\theta} + U_{\theta\theta}\theta + \{U_{\theta q}\}'\{q\} + U_{\theta\gamma}\gamma = 0 \quad (3-530)$$

$$I\ddot{\theta} + \{U_{\theta q}\}'\{q\} + U_{\theta\gamma}\gamma = 0 \quad (3-531)$$

$$\{M_{pq}\}'\ddot{\theta} + \{q\} + \left\{ \frac{r}{\lambda} \right\} \{q\} + \{U_{q\theta}\}\theta + \{U_{q\theta}\}'\{q\} + \{U_{q\gamma}\}'\gamma = \{0\} \quad (3-532)$$

$$J\ddot{\theta} + U_{\theta\theta}\theta + \{U_{\theta q}\}'\{q\} + U_{\theta\gamma}\gamma = \Gamma + \{M_{pq}\}'\{q\} \quad (3-533)$$

Eliminating $\{q\}$ from the control equation by use of Equation 3-532, we obtain

$$\begin{aligned} & (J - \{M_{pq}\}'\{M_{qp}\})\ddot{\theta} \\ & + (U_{\theta\theta} - \{M_{pq}\}'\{U_{q\theta}\})\theta \\ & + (\{U_{\theta q}\}' - \{M_{pq}\}'\{U_{q\theta}\} - \{M_{pq}\}'\left\{ \frac{r}{\lambda} \right\})\{q\} \\ & + (U_{\theta\gamma} - \{M_{pq}\}'\{U_{q\gamma}\})\gamma = \Gamma \end{aligned} \quad (3-534)$$

The "dog-wags-tail" frequency is determined from

$$(J - \{M_{pq}\}'\{M_{qp}\})\ddot{\theta} + (U_{\theta\theta} - \{M_{pq}\}'\{U_{q\theta}\})\theta = 0 \quad (3-535)$$

At this frequency the shear force across the gimbal point approaches zero, and the effective control moment is reduced.

Contrails

In concluding these comments on gimballed engine effects, we note that the equations of motion can be used to obtain the response to "hard-over" engine. In this case, we assume that the signal to the servo is a step input to command a constant gimbal angle, γ^* .

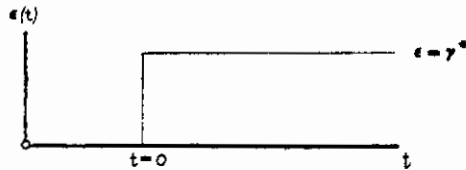

FIGURE 47 TIME HISTORY OF SIGNAL TO SERVO

The actuator moment is then given by

$$\begin{aligned} \Gamma &= J\omega_p^2 (\epsilon - \gamma) \\ &= -J\omega_p^2 \gamma + J\omega_p^2 \gamma^* \mathcal{H}(t) \end{aligned} \quad (3-536)$$

The equations of motion are

$$\begin{aligned} [M] \begin{bmatrix} \ddot{\gamma} \\ \ddot{\theta} \\ \{\ddot{q}\} \\ \ddot{\gamma} \end{bmatrix} + \left([F] + [U] + \begin{bmatrix} 0 & 0 & 0 \\ 0 & 0 & 0 \\ 0 & 0 & 0 \\ 0 & 0 & J\omega_p^2 \end{bmatrix} \right) \begin{bmatrix} \gamma \\ \theta \\ \{q\} \\ \gamma \end{bmatrix} \\ = \begin{bmatrix} 0 \\ 0 \\ \{0\} \\ J\omega_p^2 \gamma^* \end{bmatrix} \mathcal{H}(t) \end{aligned} \quad (3-537)$$

which can be solved by the routine discussed in the second part of Appendix VI.

Contrails

In the case that the thrust forces can be ignored in comparison with the inertia forces, the above equations reduce to the following simple forms

$$M\ddot{f} = 0 \quad (3-538)$$

$$I\ddot{\theta} = 0 \quad (3-539)$$

$$\{\ddot{q}\} + \{\omega^2\}\{q\} + \{M_{q\ddot{q}}\}\ddot{f} = \{0\} \quad (3-540)$$

$$J(\ddot{f} + \omega_f^2 f) + \{M_{f\ddot{q}}\}\{\ddot{q}\} = J\omega_f^2 f^* N(t) \quad (3-541)$$

3.1.3.6 Some General Considerations of the Influence of Fuel Slosh on the Lateral Motions of a Slender Launch Vehicle

We will only consider a vehicle having a single, unsegmented tank as shown by Figure 48.

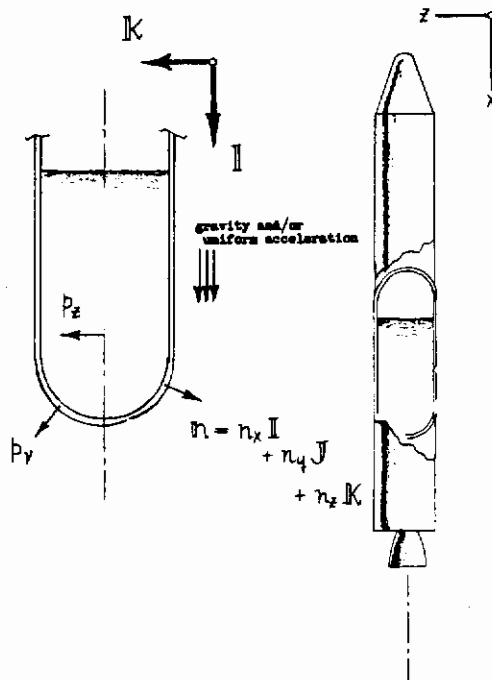

FIGURE 48 LIQUID FUEL TANK AND LAUNCH VEHICLE

Contrails

The displacement normal to the tank walls is given by

$$p_V = n \cdot p = n \cdot K p_z = n_z p_z \quad (3-542)$$

where n is a unit vector normal to the wall.

The virtual work of the wall forces is given by

$$\delta W = \iint \delta p \cdot \Sigma \cdot dS \quad (3-543)$$

For an inviscid fluid

$$\Sigma = -p \mathbf{1} \quad (3-544)$$

where p is the fluid pressure.

For the launch vehicle with empty fuel tank we have

$$T = \frac{1}{2} \int m(x) \left(\frac{\partial b_z}{\partial t} \right)^2 dx \quad (3-545)$$

$$U = \frac{1}{2} \int E(x) \left(\frac{\partial^2 b_z}{\partial x^2} \right)^2 dx \quad (3-546)$$

The influence of the fuel and its inertia is described in the virtual work of the wall pressure (Equation 3-543).

$$\delta W = \iiint \delta p_V p \, d\mu \, dk \quad (3-547)$$

If p_i , $i = 1, 2, \dots, N$ are a set of generalized coordinates for the launch vehicle, then the transformation

$$p_z = \{h_z\} \{p\} \quad (3-548)$$

gives

$$T = \frac{1}{2} \{ \dot{p} \} [A] \{ p \} \quad (3-549)$$

$$U = \frac{1}{2} \{ p \} [K] \{ p \} \quad (3-550)$$

$$\delta W = \{ \delta p \} \{ P \} \quad (3-551)$$

where

$$[A] = \int m(x) \{ h_z \} \{ h_z \}' dx \quad (3-552)$$

$$[K] = \int E(x) \left\{ \frac{d^2 h_z}{dx^2} \right\} \left\{ \frac{d^2 h_z}{dx^2} \right\}' dx \quad (3-553)$$

$$\{ P \} = \iint \{ h_z \} n_z p du dv \quad (3-554)$$

Since the pressure will depend on the motion of the walls, the fuel motion is coupled in a complicated way with the launch vehicle motion.

3.1.3.6.1 Dynamics of the Motion of the Fuel

If we let $[p(x,y,z,t)]$ be the displacement of the x-y-z particle of fluid, then we have the problem of determining the displacements of the fluid in terms of the displacements of the walls of the tank.

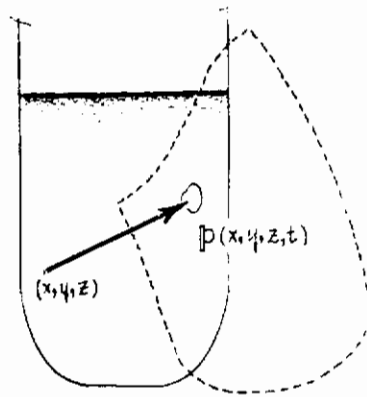

FIGURE 49 DISPLACEMENTS OF SLOSHING FUEL

The equations governing the motion are (see Paragraph 2.1.1.2, Equation 2-31)

$$\rho \frac{\partial^2 \phi}{\partial t^2} = \nabla \cdot \Sigma + P \quad (3-555)$$

In the present case

$$\Sigma = xI + yJ + zK + p \quad (3-556)$$

and thus

$$\rho \frac{\partial^2 \phi}{\partial t^2} = \nabla \cdot \Sigma + P \quad (3-557)$$

Contrails

If it is assumed that the displacements are small, the Eulerian coordinates

$$\begin{aligned} \xi &= x + p_x(x, y, z, t) \\ \eta &= y + p_y(x, y, z, t) \\ \zeta &= z + p_z(x, y, z, t) \end{aligned} \quad (3-558)$$

are approximately equal to the Lagrangian coordinates; and, moreover

$$\begin{aligned} \frac{\partial(\)}{\partial x} &= \frac{\partial(\)}{\partial \xi} \frac{\partial \xi}{\partial x} + \frac{\partial(\)}{\partial \eta} \frac{\partial \eta}{\partial x} + \frac{\partial(\)}{\partial \zeta} \frac{\partial \zeta}{\partial x} \\ &= \frac{\partial(\)}{\partial \xi} \left(1 + \frac{\partial p_x}{\partial x}\right) + \frac{\partial(\)}{\partial \eta} \frac{\partial p_y}{\partial x} + \frac{\partial(\)}{\partial \zeta} \frac{\partial p_z}{\partial x} \\ &\doteq \frac{\partial(\)}{\partial \xi} \end{aligned} \quad (3-559)$$

when the displacement gradients are small.

If the fluid is inviscid, then

$$\Sigma = -p \mathbf{1} \quad (p \text{ is the fluid pressure}) \quad (3-560)$$

for the Eulerian representation. The only body forces are those of gravity which are assumed to act parallel to the x-axis.

$$\mathbb{P} = +e g \mathbf{I} \quad (3-561)$$

and Equation 3-557 becomes

$$\rho \frac{\partial^2 \mathbf{p}}{\partial t^2} = -\nabla p + e g \mathbf{I} \quad (3-562)$$

If the fluid is assumed incompressible, the Jacobian of the deformation must be constant.

$$\begin{aligned} J &= \frac{\partial \xi}{\partial x} \cdot \frac{\partial \eta}{\partial y} \cdot \frac{\partial \zeta}{\partial z} \\ &= \left(1 + \frac{\partial p_x}{\partial x}\right) \cdot \left(1 + \frac{\partial p_y}{\partial y}\right) \cdot \left(1 + \frac{\partial p_z}{\partial z}\right) \end{aligned} \quad (3-563)$$

Continuity

for small displacements

$$\begin{aligned} J &= I \cdot J_x K + I \frac{\partial p}{\partial x} + J \frac{\partial p}{\partial y} + K \frac{\partial p}{\partial z} \\ &= 1 + \nabla \cdot \mathbf{p} \end{aligned} \quad (3-564)$$

If the Jacobian is constant, then

$$\nabla \cdot \mathbf{p} = 0 \quad (3-565)$$

If the fluid has uniform density in the undeformed state, the density is constant in space and time and the body forces have a potential,

$$\mathbf{b} = -\rho g \mathbf{z} \mathbf{I} \quad (3-566)$$

such that

$$\rho = -\nabla \cdot \mathbf{v} \quad \left(\nabla \cdot I \frac{\partial \mathbf{v}}{\partial t} + J \frac{\partial \mathbf{v}}{\partial y} + K \frac{\partial \mathbf{v}}{\partial z} \right) \quad (3-567)$$

Equation 3-562 then becomes

$$\rho \frac{\partial^2 \mathbf{p}}{\partial t^2} = -\nabla(\rho + \mathbf{v}) \quad (3-568)$$

Finally, if the deformation is assumed to be irrotational,

$$\nabla \times \mathbf{p} = 0 \quad (3-569)$$

then there exists a displacement potential, θ , such that

$$\mathbf{p} = \nabla \theta \quad (3-570)$$

From Equation 3-565 we conclude that θ satisfies Laplace's equation,

$$\nabla^2 \theta = 0 \quad (3-571)$$

Contrails

and, further, Equation 3-568 becomes

$$\nabla \left(\rho \frac{\partial^2 \vartheta}{\partial t^2} \right) = - \nabla (p + \vartheta) \quad (3-572)$$

or

$$\rho \frac{\partial^2 \vartheta}{\partial t^2} + p + \vartheta = 0 \quad (3-573)$$

The boundary condition is that the normal component of the displacement is specified on the boundary.

Since the walls and free surface constitute a closed volume, we can introduce a set of curvilinear coordinates (μ, ν, κ) such that $\nu(x, y, z) = 0$ describes the undeformed surface of this volume. The transformation from the cartesian coordinates (x, y, z) is

$$\begin{aligned} x &= x(\mu, \kappa, \nu) \\ y &= y(\mu, \kappa, \nu) \\ z &= z(\mu, \kappa, \nu) \end{aligned} \quad (3-574)$$

A point of the surface is described by μ and κ in the sense that

$$\begin{aligned} \kappa &= \kappa(\mu, \nu, 0) \\ y &= y(\mu, \nu, 0) \\ z &= z(\mu, \nu, 0) \end{aligned} \quad (3-575)$$

are the parametric equations of the surface bounding the volume of fluid.

If \mathbf{n} is a normal to this surface, then

$$p_\nu(\mu, \kappa, t) = (\mathbf{p} \cdot \mathbf{n})_{\nu=0} \quad (3-576)$$

is the normal component of the displacement at the boundary.

At those points of the boundary constituting the tank walls, p_ν is assumed to be known in terms of generalized coordinates describing the configuration of the rest of the launch vehicle.

At those points of the boundary which constitute the free surface, $p_\nu(\mu, \kappa, t)$ is not known; but on these boundaries the pressure is zero and, consequently, from Equation 3-573

$$\rho \frac{\partial^2 \vartheta}{\partial t^2} + \vartheta = 0 \quad (3-577)$$

on the free surface

but

$$\psi = -\rho g z = -\rho g (x + p_x(x, y, z, t)) \quad (3-578)$$

If \mathcal{F} is defined so that $\mathcal{F} = 0$ at the free surface, then

$$\mathcal{F} = -\rho g (x - x_f + p_x(x, y, z, t)) \quad (3-579)$$

where $x = x_f$ is the equation of the particles on the free surface. Since

$$p_x = p \cdot n \quad (3-580)$$

on the free surface, we have

$$\rho \frac{\partial \mathcal{F}}{\partial t^2} = \rho g p \cdot n \quad (3-581)$$

Thus, if we write,

$$p \cdot n - \nabla \theta \cdot n = \frac{\partial \theta}{\partial \nu} \quad (3-582)$$

we have

$$\frac{\partial \theta}{\partial \nu} = \begin{cases} p_\nu(\mu, \kappa, \nu, t) & \text{on the walls} \\ \frac{1}{g} \frac{\partial^2 \theta}{\partial t^2} & \text{on the free surface} \end{cases} \quad (3-583)$$

Now, the general solution to Laplace's equation which is defined on the interior of a closed volume and has its normal derivative specified on the boundary is

$$\theta(\mu, \kappa, \nu, t) = \iint G(\mu, \kappa, \nu; \sigma, \tau) \frac{\partial \theta}{\partial \nu}(\sigma, \tau, 0, t) d\sigma d\tau \quad (3-584)$$

This is the Neumann problem for the closed region bounded by the walls and the free surface¹. G is the Green's function of the second kind.

Use of Equation 3-583 yields

$$\theta(\mu, \kappa, \nu, t) = \iint_{(W)} G(\mu, \kappa, \nu; \sigma, \tau) p_\nu(\sigma, \tau, t) d\sigma d\tau + \iint_{(S)} \frac{1}{g} G(\mu, \kappa, \nu; \sigma, \tau) \frac{\partial^2 \theta}{\partial t^2}(\sigma, \tau, 0, t) d\sigma d\tau \quad (3-585)$$

¹See Kellogg, O. D., Foundations of Potential Theory, Dover, 1953, p. 246.

We then have the following integral equation for θ

$$\begin{aligned} \theta(\mu, \kappa, \nu, t) &= \iint_{(s)} \frac{1}{q} G(\mu, \kappa, \nu; \sigma, \tau) \frac{\partial^2 \theta}{\partial t^2}(\sigma, \tau, 0, t) d\sigma d\tau. \\ &= \iint_{(w)} G(\mu, \kappa, \nu; \sigma, \tau) p_\nu(\sigma, \tau, t) d\sigma d\tau \end{aligned} \quad (3-586)$$

At points of the interior, the pressure is given by

$$p = -\rho \frac{\partial^2 \theta}{\partial t^2} + \rho g(x-x_s) - \rho g \frac{\partial \theta}{\partial x} \quad (3-587)$$

3.1.3.6.2 Solution of the Integral Equation

Consider the homogeneous equation

$$\theta(\mu, \kappa, \nu, t) = \frac{1}{q} \iint_{(s)} G(\mu, \kappa, \nu; \sigma, \tau) \frac{\partial^2 \theta}{\partial t^2}(\sigma, \tau, 0, t) d\sigma d\tau. \quad (3-588)$$

and let

$$K(\mu, \kappa; \sigma, \tau) = -\lim_{\nu \rightarrow 0} \frac{1}{q} G(\mu, \kappa, \nu; \sigma, \tau) \quad (3-589)$$

and assume a separated solution

$$\theta(\mu, \kappa, 0, t) = \psi(\mu, \kappa) q'(t) \quad (3-590)$$

Then

$$\psi(\mu, \kappa) q''(t) = \iint_{(s)} -K(\mu, \kappa; \sigma, \tau) \psi(\sigma, \tau) d\sigma d\tau q''(t) \quad (3-591)$$

which requires

$$-\frac{q''}{q} = \text{a constant, say, } \lambda \quad (3-592)$$

Contrails

then we have the following integral equation for $\psi(\mu, \kappa)$

$$\iint_{(s)} K(\mu, \kappa; \sigma, \tau) \psi(\sigma, \tau) d\sigma d\tau = \lambda \psi(\mu, \kappa) \quad (3-593)$$

From general properties of the Green's function, we have the following symmetry condition for the kernel function, K ,

$$K(\mu, \kappa; \sigma, \tau) = K(\sigma, \tau; \mu, \kappa) \quad (3-594)$$

Equation 3-593 has a sequence of solutions

(3-595)

$$\psi = \psi_i(\mu, \kappa), \quad \lambda_i \quad i = 1, 2, \dots$$

From the symmetry condition of K , one can derive the following orthogonality conditions for the solutions

$$\iint_{(s)} \psi_i(\mu, \kappa) \psi_j(\mu, \kappa) d\mu d\kappa = 0 \quad i \neq j \quad (3-596)$$

$$\iint_{(s)} \iint_{(s)} \psi_i(\mu, \kappa) K(\mu, \kappa; \sigma, \tau) \psi_j(\sigma, \tau) d\sigma d\tau d\mu d\kappa = 0 \quad i \neq j \quad (3-597)$$

A normalizing condition can be imposed by considering the kinetic energy of the fluid¹.

$$T = -\frac{1}{2} \iint \dot{\phi} \frac{\partial \dot{\phi}}{\partial \nu} \rho d\mu d\kappa \quad (3-598)$$

for the homogeneous solution

$$\frac{\partial \phi}{\partial \nu} = \begin{cases} 0 & \text{on the walls} \\ \frac{1}{q} \frac{\partial^2 \phi}{\partial t^2} & \text{on the surface} \end{cases} \quad (3-599)$$

¹See Lamb, H., Hydrodynamics, Dover, 1945, p. 46, Equation (4).

Contrails

so that

$$\tau = -\frac{1}{2} \iint_{(s)} \dot{\Theta} \frac{\rho}{g} \bar{\Theta} \, d\mu d\kappa \quad (3-600)$$

when

$$\Theta = \psi \varrho \quad (3-601)$$

$$\tau = -\frac{1}{2} \iint_{(s)} \psi^2 \frac{\rho}{g} \, d\mu d\kappa \quad \dot{\varrho} \bar{\varrho} \quad (3-602)$$

We then choose the normalizing condition to be

$$\iint_{(s)} \frac{\rho}{g} \psi_i^2 \, d\mu d\kappa = -1 \quad (3-603)$$

or

$$\iint_{(s)} \psi_i^2 \, d\mu d\kappa = -\frac{g}{\rho} \quad (3-604)$$

Since

$$\iint_{(s)} \mathcal{K} \psi_i \, d\sigma d\tau = \lambda_i \psi_i \quad (3-605)$$

we have

$$\begin{aligned} \iint_{(s)} \psi_i \iint_{(s)} \mathcal{K} \psi_i \, d\sigma d\tau \, d\mu d\kappa & \quad (3-606) \\ &= \lambda_i \iint_{(s)} \psi_i^2 \, d\mu d\kappa \\ &= -\frac{g\lambda_i}{\rho} \end{aligned}$$

In summary

$$\iint_{(s)} \iint_{(s)} \psi_i \mathcal{K} \psi_j \, d\sigma d\tau \, d\mu d\kappa = \begin{cases} 0 & i \neq j \\ -\frac{g\lambda_i}{\rho} & i = j \end{cases} \quad (3-607)$$

$$\iint_{(s)} \psi_i \psi_j \, d\mu d\kappa = \begin{cases} 0 & i \neq j \\ -\frac{g}{\rho} & i = j \end{cases} \quad (3-608)$$

Contrails

Returning to the nonhomogeneous equation, we have

$$\begin{aligned} \theta(\mu, \kappa, 0, t) + \iint_{(S)} \mathcal{K}(\mu, \kappa; \sigma, \tau) \frac{\partial^2 \theta}{\partial t^2}(\sigma, \tau, 0, t) d\sigma d\tau \\ - \iint_{(W)} q \mathcal{K}(\mu, \kappa; \sigma, \tau) p_\gamma(\sigma, \tau, t) d\sigma d\tau \end{aligned} \quad (3-609)$$

We will try to find a solution in the form

$$\begin{aligned} \theta(\mu, \kappa, 0, t) = \sum_i \psi_i(\mu, \kappa) q_i(t) \\ - \iint_{(W)} q \mathcal{K}(\mu, \kappa; \sigma, \tau) p_\gamma(\sigma, \tau, t) d\sigma d\tau \end{aligned} \quad (3-610)$$

Substituting this into Equation 3-609, we obtain

$$\begin{aligned} \sum_i \psi_i q_i + \iint_{(S)} \mathcal{K} \sum_i \psi_i d\sigma d\tau \ddot{q}_i \\ - \iint_{(S)} \mathcal{K} \iint_{(W)} q \mathcal{K} \frac{\partial^2 p_\gamma}{\partial t^2} d\mu d\kappa d\sigma d\tau = 0 \end{aligned} \quad (3-611)$$

but

$$\psi_i = \frac{1}{\lambda_i} \iint_{(S)} \mathcal{K} \psi_i d\sigma d\tau \quad (3-612)$$

so that

$$\iint_{(S)} \left(\sum_i \frac{1}{\lambda_i} \mathcal{K} \psi_i q_i + \mathcal{K} \sum_i \psi_i \ddot{q}_i - \mathcal{K} \iint_{(W)} q \mathcal{K} \frac{\partial^2 p_\gamma}{\partial t^2} d\mu d\kappa \right) d\sigma d\tau = 0 \quad (3-613)$$

or

$$\sum_i \frac{1}{\lambda_i} \psi_i q_i + \psi_i \ddot{q}_i = \iint_{(W)} q \mathcal{K} \frac{\partial^2 p_\gamma}{\partial t^2} d\sigma d\tau \quad (3-614)$$

On multiplying by $\psi_j(\mu, \kappa)$ and integrating over (S), we obtain

$$\begin{aligned} \sum_i \iint_{(S)} \psi_j \psi_i d\mu d\kappa \left(q_i \frac{1}{\lambda_i} + \ddot{q}_i \right) \\ = \iint_{(S)} \psi_j \iint_{(W)} q \mathcal{K} \frac{\partial^2 p_\gamma}{\partial t^2} d\sigma d\tau d\mu d\kappa \end{aligned} \quad (3-615)$$

Using the orthogonality conditions, we obtain

$$\ddot{q}_i + \frac{1}{\lambda_i} \dot{q}_i = -e \int_{(s)} \psi_i \int_{(w)} K \frac{\partial^2 p_v}{\partial t^2} d\sigma d\tau d\mu d\kappa \quad (3-616)$$

Interchanging the order of integration on the right, we obtain

$$\begin{aligned} \int_{(s)} \psi_i \int_{(w)} K \frac{\partial^2 p_v}{\partial t^2} d\sigma d\tau d\mu d\kappa \\ = \int_{(w)} \frac{\partial^2 p_v}{\partial t^2} \int_{(s)} \psi_i K d\sigma d\tau d\mu d\kappa \\ = \int_{(w)} \frac{\partial^2 p_v}{\partial t^2} \lambda_i \psi_i d\mu d\kappa \end{aligned} \quad (3-617)$$

Using this result in Equation 3-616, we finally obtain

$$\frac{d^2 q_i}{dt^2} + \frac{1}{\lambda_i} \dot{q}_i = -e \lambda_i \int_{(w)} \psi_i(\mu, \kappa) \frac{\partial^2 p_v}{\partial t^2}(\mu, \kappa, t) d\mu d\kappa \quad (3-618)$$

Now the pressure on the walls is, from Equation 3-587,

$$p = -e \frac{\partial^2 \phi}{\partial t^2} + e q (\lambda - x_s + p_x) \quad (3-619)$$

in which we neglect the contribution of p_x to the total force on the walls, so that

$$p = -e \frac{\partial^2 \phi}{\partial t^2} + e q (\lambda - x_s) \quad (3-620)$$

Now, from Equation 3-610,

$$e \frac{\partial^2 \phi}{\partial t^2} = e \sum_i \psi_i \ddot{q}_i - e q \int_{(w)} K \frac{\partial^2 p_v}{\partial t^2} d\sigma d\tau \quad (3-621)$$

but from Equation 3-614,

$$\rho \iint_{(w)} \kappa \frac{\partial^2 \psi}{\partial t^2} d\omega d\tau = \sum_i \frac{1}{\lambda_i} \psi_i \dot{q}_i + \psi_i \ddot{q}_i \quad (3-622)$$

so that

$$e \frac{\partial^2 \theta}{\partial t^2} = -e \sum_i \frac{1}{\lambda_i} \psi_i \dot{q}_i \quad (3-623)$$

The wall pressure is then

$$p = e \sum_i \frac{1}{\lambda_i} \psi_i \dot{q}_i + \rho g (x - x_s) \quad (3-624)$$

3.1.3.6.3 Coupling of Sloshing Fuel with Launch Vehicle Motion

In order to express these results in terms of the launch vehicle generalized coordinates, we use Equations 3-542 and 3-548

$$p_v = n_z \{h_z\}' \{p\} \quad (3-625)$$

and write Equation 3-618 as

$$\{\ddot{q}\} + \left\{ \frac{1}{\lambda} \right\} \{q\} = -e \left\{ \lambda \right\} \iint_{(w)} \{\psi\} \{h_z\}' n_z d\omega d\kappa \{\ddot{p}\} \quad (3-626)$$

and Equation 3-547 becomes

$$\begin{aligned} \delta W &= \iint_{(w)} \delta p_v p d\omega d\kappa \\ &= \{\delta p\}' \iint_{(w)} \{h_z\} \{\psi\}' n_z d\omega d\kappa e \left\{ \frac{1}{\lambda} \right\} \{q\} \\ &\quad + \rho g \{\delta p\}' \iint_{(w)} \{h_z\} n_z (x - x_s) d\omega d\kappa \end{aligned} \quad (3-627)$$

Contrails

If the tank has axial symmetry, the net hydrostatic force in the lateral direction is zero.

$$\iint_{(w)} \{h_z\} (x-x_s) n_z d\mu d\kappa = \{0\} \quad (3-628)$$

The generalized forces defined in Equation 3-554 are then

$$\{P\} = \rho \iint_{(w)} \{h_z\} \{i\psi\}' n_z d\mu d\kappa \{r'_{\lambda}\} \{q\} \quad (3-629)$$

If we introduce

$$[\eta] = \iint_{(w)} \{h_z\} \{i\psi\}' n_z d\mu d\kappa \quad (3-630)$$

then we have

$$\{i\ddot{q}\} + \{r'_{\lambda}\} \{q\} = -\rho \{r_{\lambda}\} [\eta]' \{i\ddot{p}\} \quad (3-631)$$

and Lagrange's equations for expressions (Equations 3-549, 3-550, and 3-551) give

$$[A] \{i\ddot{p}\} + [K] \{p\} = \rho [\eta] \{r'_{\lambda}\} \{q\} \quad (3-632)$$

These may be rearranged by substituting Equation 3-631 into Equation 3-632.

$$\begin{aligned} ([A] + \rho^2 [\eta] \{r_{\lambda}\} [\eta]') \{i\ddot{p}\} + [K] \{p\} \\ = -\rho [\eta] \{r_{\lambda}\} \{i\ddot{q}\} \end{aligned} \quad (3-633)$$

$$\{i\ddot{q}\} + \{r'_{\lambda}\} \{q\} = -\rho \{r_{\lambda}\} [\eta]' \{i\ddot{p}\} \quad (3-634)$$

These equations can be somewhat simplified if we introduce the transformation

$$\{q\} = e^{r\lambda^2} [\eta]' (\{s\} - \{p\}) \quad (3-635)$$

where the s_i , $i = 1, 2, \dots, N$ are the "sloshing coordinates." Equations 3-633 and 3-634 become

$$([A] + [A_R] + [A_S]) \{\ddot{p}\} + [K] \{p\} = -[A_S] \{\ddot{s}\} \quad (3-636)$$

$$[A_S] \{\ddot{s}\} + [K_S] \{s\} = -[K_S] \{p\} \quad (3-637)$$

where

$$[A_R] = e^2 [\eta] r \lambda [\eta]' \quad = \text{the rigid fuel mass matrix} \quad (3-638)$$

$$[A_S] = e^2 [\eta] r \lambda^2 [\eta]' \quad = \text{the sloshing fuel mass matrix} \quad (3-639)$$

$$[K_S] = e^2 [\eta] r \lambda [\eta]' \quad = \text{the sloshing fuel stiffness matrix} \quad (3-640)$$

Equations 3-636 and 3-637 are the basis for a mechanical analogy in which the motion of the fuel is represented by the motion of an equivalent set of masses and springs.

3.1.3.7 Flutter and Divergence of Launch Vehicle Lifting Surfaces

3.1.3.7.1 A General Method of Flutter and Divergence Analysis

In considering the aeroelastic stability of stabilizing fins or other launch vehicle lifting surfaces, the generalized coordinates chosen to describe the system may include coordinates defining the motion of the launch vehicle itself although constraint of this motion usually has very little effect on the flutter speed. In any case, the equations are of the same form and are derived from Lagrange's equations.

$$\frac{d}{dt} \left(\frac{\partial T}{\partial \dot{p}_i} \right) - \frac{\partial T}{\partial p_i} + \frac{\partial U}{\partial p_i} + \frac{\partial R}{\partial p_i} = P_i \quad (3-641)$$

where, for small motions,

Contrails

$T = \text{kinetic energy} = \frac{1}{2} \{\dot{p}\}' [A] \{\dot{p}\}$

$U = \text{potential energy} = \frac{1}{2} \{p\}' [K] \{p\}$

$R = \text{Rayleigh dissipation function} = \frac{1}{2} \{\dot{p}\}' [B] \{\dot{p}\}$

$P_i = \text{generalized external forces}$

$\{p\} = \text{matrix of displacements}$

$[A] = \text{inertial coefficient matrix}$

$[K] = \text{stiffness coefficient matrix}$

$[B] = \text{viscous damping coefficient matrix}$

The damping may be assumed to have the same distribution as the structural stiffness, so that the damping coefficient matrix is proportional to the stiffness matrix (see also Paragraph 2.2.3.5).

$$[B] = \rho [K] \quad (3-642)$$

The vibration modes of the surface may be derived and used as a transformation to reduce the number of degrees-of-freedom:

$$\{p\} = [\varphi] \{q\} \quad (3-643)$$

where $\{q\}$ is the column of "modal" generalized coordinates.

Lagrange's equations in terms of modal generalized coordinates are:

$$\frac{d}{dt} \left(\frac{\partial T}{\partial \dot{q}_i} \right) - \frac{\partial T}{\partial q_i} + \frac{\partial U}{\partial q_i} + \frac{\partial R}{\partial \dot{q}_i} = Q_i \quad (3-644)$$

Then:

$$T = \frac{1}{2} \{\dot{p}\}' [A] \{\dot{p}\} = \frac{1}{2} \{\dot{q}\}' [M] \{\dot{q}\} \quad (3-645)$$

$$U = \frac{1}{2} \{p\}' [K] \{p\} = \frac{1}{2} \{q\}' [F] \{q\} \quad (3-646)$$

$$R = \frac{1}{2} \{\dot{p}\}' [B] \{\dot{p}\} = \frac{1}{2} \{\dot{q}\}' [R] \{\dot{q}\} \quad (3-647)$$

$$\delta W = \{\delta p\}' \{P\} = \{\delta q\}' \{Q\} \quad (3-648)$$

where

$$[M] = [\varphi]' [A] [\varphi] \quad (3-649)$$

$$[F] = [\varphi]' [K] [\varphi] \quad (3-650)$$

Contrails

$$[R] = [\varphi]'[B][\varphi] \quad (3-651)$$

$$\{Q\} = [\varphi]'\{P\} \quad (3-652)$$

Substitution of these relations into Lagrange's equations gives

$$[M]\{\ddot{q}\} + [R]\{\dot{q}\} + [F]\{q\} = \{Q\} \quad (3-653)$$

Since the solution to Equation 3-653 is extremely complex with q a function of time, in the flutter equations it is convenient to calculate forces as a function of the frequency, ω . This can be done by using Fourier transforms as shown below.

The Fourier transform is defined by

$$\{q(t)\} = \int_{-\infty}^{\infty} \{\bar{q}(\omega)\} e^{i\omega t} d\omega \quad (3-654)$$

Now, the virtual work of aerodynamic forces can be expressed as:

$$\delta W = -\frac{1}{2} \rho \omega^2 \int_{-\infty}^{\infty} \{\delta q\}' [C(\frac{\omega}{V_\infty}, M_\infty)] \{\bar{q}(\omega)\} e^{i\omega t} d\omega \quad (3-655)$$

where:

ω = Fourier transform variable (circular frequency)

ρ = air density

V_∞ = airspeed

M_∞ = Mach number

$[C(\frac{\omega}{V_\infty}, M_\infty)]$ = matrix of generalized airforces

The generalized forces associated with the q_i are

$$\{Q(t)\} = -\frac{1}{2} \rho \omega^2 \int_{-\infty}^{\infty} [C(\frac{\omega}{V_\infty}, M_\infty)] \{\bar{q}(\omega)\} e^{i\omega t} d\omega \quad (3-656)$$

and the Fourier transform of these forces is

$$\{\bar{Q}(\omega)\} = -\frac{1}{2} \rho \omega^2 [C(\frac{\omega}{V_\infty}, M_\infty)] \{\bar{q}(\omega)\} \quad (3-657)$$

Equation 3-655 can be taken as an expression defining the aerodynamic matrix, $[C]$. If quasi-steady airforces are used, then

$$\delta W = -\frac{1}{2} \rho \omega^2 \{\delta q\}' \left([C_R]\{q\} + \frac{1}{V_\infty} [C_I]\{\dot{q}\} \right) \quad (3-658)$$

Contrails

and, for this case, the complex aerodynamic matrix is

$$[C(\frac{\omega}{V_\infty}, M_\infty)] = [C_R] + i(\frac{\omega}{V_\infty})[C_I] \quad (3-659)$$

Substitution of Equations 3-654 and 3-656 into Equation 3-653 gives

$$\begin{aligned} \int_{-\infty}^{\infty} -\omega^2 [M] \{ \bar{q} \} e^{i\omega t} d\omega \\ + \int_{-\infty}^{\infty} i\omega [R] \{ \bar{q} \} e^{i\omega t} d\omega \\ + \int_{-\infty}^{\infty} [F] \{ \bar{q} \} e^{i\omega t} d\omega \\ = -\frac{1}{2} \rho_\infty V_\infty^2 \int_{-\infty}^{\infty} [C] \{ \bar{q} \} e^{i\omega t} d\omega \end{aligned} \quad (3-660)$$

or

$$\int_{-\infty}^{\infty} (-\omega^2 [M] + i\omega [R] + [F] + \frac{1}{2} \rho_\infty V_\infty^2 [C]) \{ \bar{q} \} e^{i\omega t} d\omega = \{ 0 \} \quad (3-661)$$

which implies

$$(-[M] + \frac{i\omega}{\omega^2} [R] + \frac{1}{\omega^2} [F] + \frac{\rho_\infty}{2} (\frac{V_\infty}{\omega})^2 [C]) \{ \bar{q} \} = \{ 0 \} \quad (3-662)$$

Now, consider

$$\frac{i\omega}{\omega^2} [R] + \frac{1}{\omega^2} [F]$$

By using Equations 3-642, 3-650, and 3-651, we have

$$[R] = \beta [F] \quad (3-663)$$

Then, substituting, we have

$$\frac{i\omega}{\omega^2} [R] + \frac{1}{\omega^2} [F] = (\frac{i\omega\beta}{\omega^2} + \frac{1}{\omega^2}) [F] \quad (3-664)$$

Rewriting Equation 3-662, and substituting Equation 3-664, we have:

$$(-[M] + \frac{1+i\omega\beta}{\omega^2} [F] + \frac{\rho_\infty}{2} (\frac{V_\infty}{\omega})^2 [C]) \{ \bar{q} \} = \{ 0 \} \quad (3-665)$$

Contrails

Premultiplying by¹

$$[G] = [F]^{-1} \quad (3-666)$$

and introducing

$$\lambda = \frac{1 + i\omega\beta}{\omega^2} \quad (3-667)$$

we obtain

$$(\lambda [1] - [N])\{\bar{q}\} = \{0\} \quad (3-668)$$

where

$$[N(\frac{\omega}{v_\infty}, M_\infty, \rho_\infty)] = [G] \left([M] - \frac{\rho_\infty}{2(\frac{\omega}{v_\infty})^2} [C(\frac{\omega}{v_\infty}, M_\infty)] \right) \quad (3-669)$$

The solution to Equation 3-668 yields the following:

$$\{\bar{q}\} = \{0\} \quad (3-670)$$

or

$$\Delta(\lambda) = |\lambda [1] - [N]| = 0 \quad (3-671)$$

For other than the trivial solution $\{\bar{q}(\omega)\} = \{0\}$, the determinant must be equal to zero. This can be expanded for each value of ω/v_∞ as an N^{th} order polynomial in λ with complex coefficients. Several methods of expansion are available; for example, Danielewski's method. The roots of the polynomial, $\Delta(\lambda) = 0$, are obtained by Newton's method². The damping, β , frequency, ω , and speed, v_∞ , are then calculated from these roots by the following relationships.

From Equation 3-667, we have

$$\lambda = \lambda_R + i\lambda_I = \frac{1 + i\omega\beta}{\omega^2} \quad (3-672)$$

$$\lambda_R = \frac{1}{\omega^2} \quad (3-673)$$

¹The flutter equations can be reduced to the form of Equation 3-668 even when $[F]^{-1}$ does not exist so that the method is also appropriate for unrestrained systems.

²A method employing direct solution of the eigenvalue problem has lately been used with success on systems requiring a large number of modes for their description. See W. P. Rodden, et al, Flutter and Vibration Analysis by a Modal Method: Analytical Development and Computational Procedure, Aerospace Corporation, Report No. TDR-169(3230-11) TN-15, 31 July 1963.

Contrails

$$\lambda_I = \frac{\beta}{\omega} \quad (3-674)$$

So that:

$$\beta = \frac{\lambda_I}{\sqrt{\lambda_R}} \quad (3-675)$$

$$\omega = \frac{1}{\sqrt{\lambda_R}} \quad (3-676)$$

The airspeed is then calculated from the value of $\omega/\sqrt{\lambda_R}$ which has been selected:

$$v_{\omega} = \frac{v_{\infty}}{\omega} \omega = \frac{1}{\left(\frac{\omega}{v_{\infty}}\right)} \sqrt{\frac{1}{\lambda_R}} \quad (3-677)$$

The flutter solution is obtained when the value of β calculated from Equation 3-657 agrees with experimental or theoretical estimates of β . This is the airspeed at which neutral stability exists. True flutter speed occurs where the airspeed calculated in Equation 3-677 coincides with the assumed Mach number.

To determine the aeroelastic divergence speed, that is, where neutral stability exists as the frequency approaches zero, refer to Equation 3-661, and rewrite with $\omega = 0$.

$$\left(\frac{1}{2} \rho \alpha v_{\infty}^2 [C(0, M_{\infty})] + [F] \right) \{ \bar{q} \} = \{ 0 \} \quad (3-678)$$

Let

$$[F]^{-1} = [G] \quad (3-679)$$

This becomes a simple relationship of real equations dependent upon the dynamic pressure and the internal restoring forces. If we assume a solution other than the trivial solution $\{ \bar{q}(\omega) \} = \{ 0 \}$, the following determinant can be expanded as an N^{th} order polynomial with real coefficients in $\frac{\rho \alpha v_{\infty}^2}{2}$ for each value of Mach number.

$$\left| \frac{1}{2} \rho \alpha v_{\infty}^2 [G] + [C(0, M_{\infty})] \right| = 0 \quad (3-680)$$

From this relationship the solution for $\frac{1}{2} \rho \alpha v_{\infty}^2$ can be easily obtained. It should be pointed out that this is a special case in the flutter equations whereby selection of the parameter $(\omega/v_{\infty}) = 0$ (frequency equal to zero) will also yield the aeroelastic divergence speed.

To correlate the modal solutions with test data for checking flutter analyses, consider the following. The equations of motion, including viscous damping, can be written in the following form (see Equation 2-296):

Contrails

$$\frac{d^2 q_n}{dt^2} + 2\zeta_n \omega_n \frac{dq_n}{dt} + \omega_n^2 q_n = Q_n \quad (3-681)$$

where:

q_n = the normal coordinate for the n^{th} mode of vibration

Q_n = generalized forces in the n^{th} mode of vibration

From Equation 3-653

$$[M]\ddot{\mathbf{q}} + [R]\dot{\mathbf{q}} + [F]\mathbf{q} = \mathbf{Q} \quad (3-682)$$

By comparison of Equations 3-681 and 3-682, we must have

$$[M] = [1] \quad (3-683)$$

$$[R] = [2\zeta_n \omega_n] \quad (3-684)$$

$$[F] = [\omega_n^2] \quad (3-685)$$

But, from Equation 3-663,

$$[R] = \beta [F] \quad (3-686)$$

Hence:

$$2\zeta_n \omega_n = \beta \omega_n^2 \quad (3-687)$$

or

$$\beta = \frac{2\zeta_n}{\omega_n} \quad (3-688)$$

This implies that there is a different percent of critical damping present in each mode which varies with the natural frequency and mode number. For structures where the damping distribution is proportional to the stiffness distribution, the critical damping factor, ζ_n , is higher in the higher frequency modes, that is:

$$\zeta_n = \frac{\beta}{2} \omega_n \quad (3-689)$$

An example of determining β experimentally is shown by Figure 50. The data have been obtained from a restrained surface ground vibration test. These data are listed in Table 9 and pictured in Figure 50.

Figure 51 shows the graphical representation of the solution of the flutter determinant.

TABLE 9
TABULATION OF EXPERIMENTAL DATA FROM GROUND VIBRATION TEST

Mode Number n	Critical Damping Factor ζ_n	Frequency (Rad/Sec) ω_n	$\frac{2\zeta_n}{\omega_n} \times 10^3$ (Sec)
1	0.00945	41.91	0.451
2	0.0087	104.74	0.166
3	0.0196	139.61	0.281
4	0.0154	176.56	0.174
5	Not available	206.15	Not available
6	0.0152	255.10	0.1192

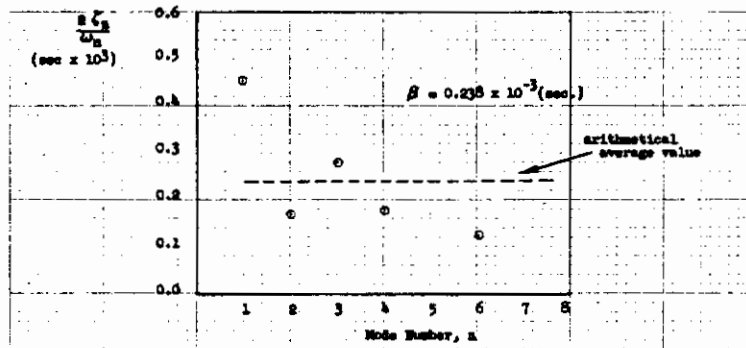

FIGURE 50 ESTIMATION OF β FROM GROUND VIBRATION TEST DATA

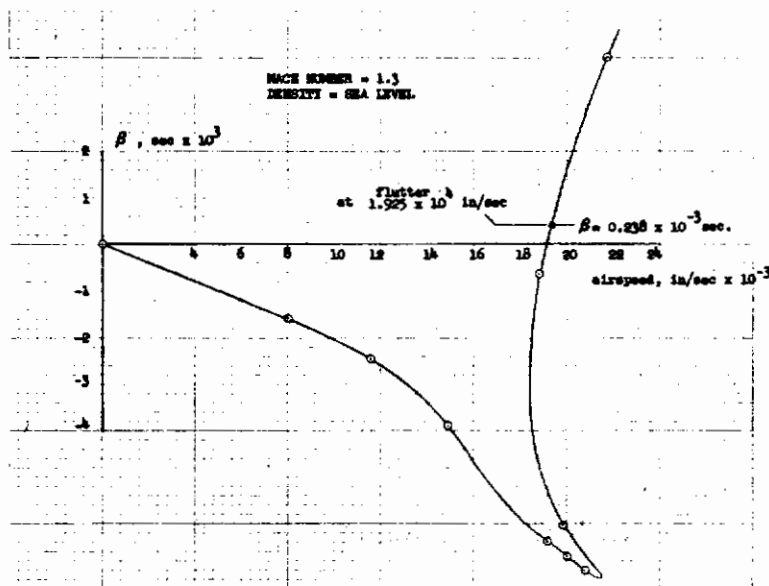

FIGURE 51 GRAPHICAL REPRESENTATION OF SOLUTION OF FLUTTER DETERMINANT

3.1.3.7.2 A Root-Plane Method of Flutter Analysis for Quasi-Steady Aerodynamic Forces

If quasi-steady aerodynamic forces are assumed, the equations of the previous section (Equation 3-653) can be written as

$$[M]\ddot{q} + [R]\dot{q} + [F]q = \{Q\} \quad (3-690)$$

with

$$\{Q\} = -\frac{1}{2}\rho_0 v_0^2 ([C_R]Hq + \frac{1}{v_0} [C_I]H\dot{q}) \quad (3-691)$$

(see Equation 3-658)

In the present case we will not assume any relation between the damping and stiffness matrix (such as Equation 3-642)

If we introduce

$$\{n\} = \{\dot{q}\} \quad (3-692)$$

Then the above equations can be written as

$$\begin{aligned} \{\dot{n}\} + [M]^{-1}[R]n + [M]^{-1}[F]q \\ + \frac{1}{2}\rho_0 v_0^2 [M]^{-1}([C_R]Hq + \frac{1}{v_0} [C_I]Hn) = \{0\} \end{aligned} \quad (3-693)$$

$$\{\dot{q}\} - \{n\} = \{0\} \quad (3-694)$$

These equations may be rewritten as a single matrix equation

$$\begin{bmatrix} \{\dot{n}\} \\ \{\dot{q}\} \end{bmatrix} - [N] \begin{bmatrix} \{n\} \\ \{q\} \end{bmatrix} = \{0\} \quad (3-695)$$

where

$$[N] = \begin{bmatrix} -[M]^{-1}([R] + \frac{\rho_0 v_0}{2} [C_I]) & -[M]^{-1}([F] + \frac{\rho_0 v_0^2}{2} [C_R]) \\ \mathbf{1} & [0] \end{bmatrix} \quad (3-696)$$

If we take the Laplace transform of these equations, we obtain

$$(s \mathbf{I}_1 - [\mathbf{N}]) \begin{Bmatrix} \{\tilde{u}\} \\ \{\tilde{v}\} \end{Bmatrix} = \{0\} \quad (3-697)$$

The stability of the system is described by the characteristic equation

$$\Delta(s) = |s \mathbf{I}_1 - [\mathbf{N}]| = 0 \quad (3-698)$$

Unlike the polynomial in Equation 3-671, the above polynomial has real coefficients and thus the roots of this polynomial occur in conjugate pairs.

The matrix, $[\mathbf{N}]$, is a function of airspeed V_∞ , Mach number, M_∞ , and air density, ρ_∞ . For the trajectory of a launch vehicle, these parameters can be related to flight time. For a given trajectory then, the matrix, $[\mathbf{N}]$, can be related to a single variable. Thus, the roots to Equation 3-698 can be regarded as changing continuously with a parametric variation of flight time along the boost trajectory.

If we let σ and ω be the real and imaginary parts of the i^{th} root to Equation 3-698, then

$$s_i = \sigma_i + i\omega_i \quad (3-699)$$

which may be plotted as a point in the (σ, ω) plane.

Flutter or divergence is indicated when one of the roots passes into the unstable part of the root plane ($\sigma > 0$). Figure 52 is a typical plot.

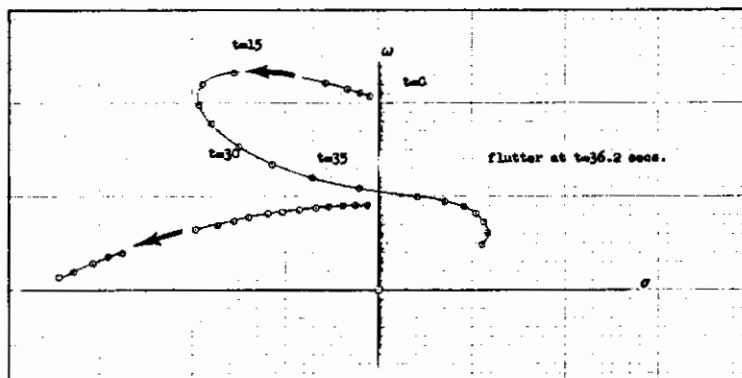

FIGURE 52 LOCUS OF THE FLUTTER ROOTS FOR A PARAMETRIC VARIATION OF FLIGHT TIME

The stability of the system is more evident from a plot of the real part of the root as shown in Figure 53.

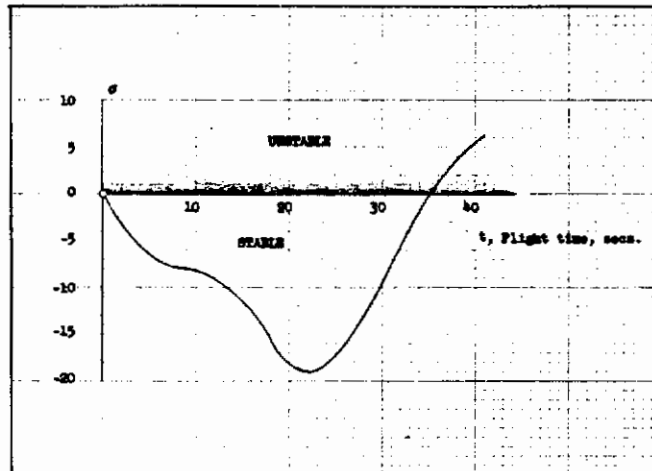

FIGURE 53 DAMPING VERSUS FLIGHT TIME

3.1.4 Response of the Missile to Continuous Random Turbulence

If it is assumed that the control system does not respond to the frequencies of turbulence in the atmosphere, the loads due to atmospheric turbulence may be obtained by assuming the control locked in the $\gamma = 0$ position. The appropriate equations may be obtained from Equations 3-27, 3-28, and 3-29 by setting $\gamma = 0$.

$$T = \frac{1}{2} \{ \dot{p} \}^T [A] \{ \dot{p} \} \quad (3-700)$$

$$U = \frac{1}{2} \{ p \}^T [K] \{ p \} \quad (3-701)$$

$$\delta W = -\frac{1}{2} \rho \omega^2 \{ \delta p \}^T [A] \{ \alpha \} \quad (3-702)$$

$$\{ \alpha \} = [\Delta] \{ p \} + \frac{1}{v_\omega} \{ \dot{p} \} \quad (3-703)$$

In addition, we have the virtual work done by the gust forces

$$\delta W = -\frac{1}{2} \rho \omega^2 \int_0^L \delta p_z \frac{\partial C_L}{\partial \alpha}(x) \frac{w(x,t)}{v_\omega} dx \quad (3-704)$$

where $w(x,t)$ is the downwash of the turbulent atmosphere at a point, x , on the missile. Assuming that the velocity of atmospheric particles is stationary in space, we have

$$w(x,t) = f(v_0 t - x) \quad (3-705)$$

where $f(\lambda)$ is a function giving the distribution of gust velocities as a function of the distance, λ , along a fixed path in space.

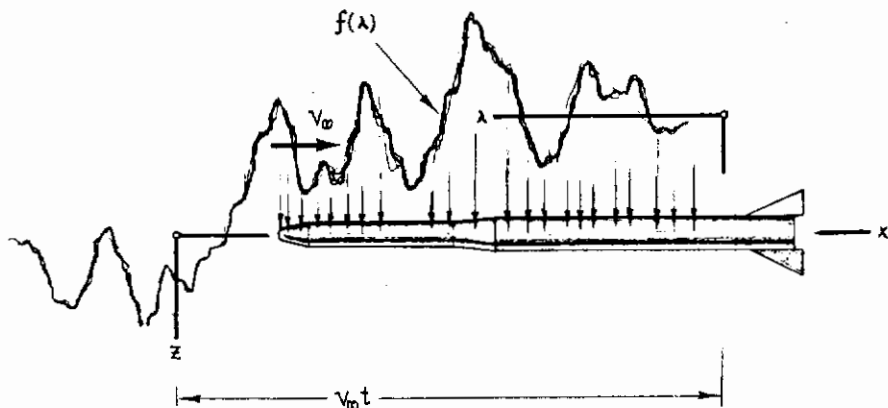

FIGURE 54 MISSILE ENCOUNTERING A TURBULENT ATMOSPHERE

The function $f(\lambda)$ is assumed to be a random function whose statistical characteristics are described by von Karman's well-known formula for the power spectrum of fluid velocities in a locally turbulent fluid¹.

$$\Phi[f(\lambda); \Omega] = \sigma \frac{L}{\pi} \frac{1 + 3\Omega^2 L^2}{(1 + \Omega^2 L^2)^2} \quad (3-706)$$

The power spectrum is a "functional" of the random function, $f(\lambda)$, and an ordinary function of the frequency variable, Ω . In this expression, Ω has the units of (length)⁻¹; and corresponds to a "wave length" variable for the oscillations in space of the gust velocities. Also, σ is the root mean square value of $f(\lambda)$ and L is the "scale" of the turbulence².

The gust forces can be written for the discrete system by using the interpolation method which gives a relation of the form

$$p_z(x,t) = \{h_z(x)\} \{p(t)\} \quad (3-707)$$

¹This is discussed in several sources; in particular, H. S. Tsien, Engineering Cybernetics, McGraw-Hill, 1954.

²See NASA Report 1272, A Reevaluation of Data on Atmospheric Turbulence for Application in Spectral Calculations, by Harry Press, May T. Meadows, and Ivan Hadlock, 1956.

Contrails

The functions, $h_z^{(i)}(x)$, for the diparabolic formula are given in Equation 2-451 of Paragraph 2.3.3.1 of this report. Equation 3-704 can then be written as

$$\delta W = \frac{1}{2} \rho_w v_w^2 \{ \delta p \}^T \int_0^L \{ h_z(x) \} \frac{\partial C_L(x)}{\partial \alpha} \frac{w(x,t)}{v_w} dx \quad (3-708)$$

The gust downwash at the i^{th} collocation point can be written as

$$w_i(t) = w(x_i, t) = f(v_w t - x_i) \quad (3-709)$$

and the interpolation formula can be used to write

$$\begin{aligned} w(x, t) &= \{ h_z(x) \}^T \{ w(t) \} \\ &= \{ h_z(x) \}^T \{ f(v_w t - x_i) \} \end{aligned} \quad (3-710)$$

We then have

$$\delta W = \frac{1}{2} \rho_w v_w^2 \{ \delta p \}^T [A] \{ \frac{f(v_w t - x_i)}{v_w} \} \quad (3-711)$$

where

$$[A] = \int_0^L \{ h_z(x) \} \frac{\partial C_L(x)}{\partial \alpha} \{ h_z(x) \}^T dx \quad (3-712)$$

which is the matrix of aerodynamic influence coefficients introduced in Equation 3-18.

Using Lagrange's equations, we obtain

$$\begin{aligned} [A] \ddot{\{p\}} + [K] \{p\} + \frac{1}{2} \rho_w v_w^2 [A] \left([\Delta] \{p\} + \frac{1}{v_w} \dot{\{p\}} \right) \\ = \frac{1}{2} \rho_w v_w^2 [A] \left\{ \frac{f(v_w t - x_i)}{v_w} \right\} \end{aligned} \quad (3-713)$$

The effective loads are

$$\begin{aligned} \{F\} = - [A] \ddot{\{p\}} - \frac{1}{2} \rho_w v_w^2 [A] \left([\Delta] \{p\} + \frac{1}{v_w} \dot{\{p\}} \right) \\ + \frac{1}{2} \rho_w v_w^2 [A] \left\{ \frac{f(v_w t - x_i)}{v_w} \right\} \end{aligned} \quad (3-714)$$

To solve the equations of motion, we make the modal transformation

$$\{p\} = [\varphi] \{q\} \quad (3-715)$$

Contrails

which is assumed to include rigid body modes; i.e.,

$$\{\varphi\}_1 = \{1\}, \quad q_1 = J, \quad \{\varphi\}_2 = \{\bar{x} - x\}, \quad q_2 = \theta \quad (3-716)$$

Substituting this into Equation 3-713 and premultiplying by $[\phi]'$, we obtain

$$[M]\ddot{\bar{q}} + [F]\dot{\bar{q}} + \frac{1}{2}\rho a v_\infty^2 \left([C_R]\bar{q} + \frac{1}{v_\infty} [C_I]\dot{\bar{q}} \right) = \{Q\} \quad (3-717)$$

where

$$\{Q(\omega)\} = \frac{1}{2}\rho a v_\infty^2 [\varphi]' [\Lambda] \left\{ \frac{f(y_\infty t - x_i)}{v_\infty} \right\} \quad (3-718)$$

and

$$[M] = [\varphi]' [A] [\varphi] \quad (3-719)$$

$$[F] = [\varphi]' [K] [\varphi] \quad (3-720)$$

$$[C_R] = [\varphi]' [\Lambda] [\Delta] [\varphi] \quad (3-721)$$

$$[C_I] = [\varphi]' [\Lambda] [\varphi] \quad (3-722)$$

In order to solve Equation 3-717 and obtain appropriate transfer functions, we assume $\{q(t)\}$ to be expressed in terms of its Fourier transform as follows:

$$\{q(t)\} = \int_{-\infty}^{\infty} \{\bar{q}(\omega)\} e^{i\omega t} d\omega \quad (3-723)$$

The corresponding inverse transform is¹

$$\{\bar{q}(\omega)\} = \frac{1}{2\pi} \int_{-\infty}^{\infty} \{q(t)\} e^{-i\omega t} dt \quad (3-724)$$

Introducing Equation 3-723 into Equation 3-717, we obtain

$$\int_{-\infty}^{\infty} \left(-\omega^2 [M] + [F] + \frac{1}{2}\rho a v_\infty^2 \left([C_R] + \frac{i\omega}{v_\infty} [C_I] \right) \right) \{\bar{q}(\omega)\} e^{i\omega t} d\omega = \{Q(t)\} \quad (3-725)$$

By definition of the Fourier transform, we have

$$\{Q(t)\} = \int_{-\infty}^{\infty} \{\bar{Q}(\omega)\} e^{i\omega t} d\omega \quad (3-726)$$

¹The convention for the form of the Fourier transform used here agrees with the engineering artifice of assuming "harmonic motion" of the form $\{q(t)\} = \{\bar{q}\} e^{i\omega t}$.

and by comparison with Equation 3-725,

$$\left(-\omega^2[M] + [F] + \frac{1}{2} \rho_0 v_0^2 ([C_R] + \frac{i\omega}{v_0} [C_I]) \right) \{ \bar{q}(\omega) \} = \{ \bar{Q}(\omega) \} \quad (3-727)$$

Using Equation 3-718, we obtain the inverse transform

$$\begin{aligned} \{ \bar{Q}(\omega) \} &= \frac{1}{2\pi} \int_{-\infty}^{\infty} \frac{\rho_0 v_0^2}{2} [\varphi]'[\Lambda] \{ f(v_0 t - x_i) \} e^{-i\omega t} dt \\ &= \frac{\rho_0 v_0^2}{2} [\varphi]'[\Lambda] \frac{1}{2\pi} \int_{-\infty}^{\infty} \{ f(v_0 t - x_i) \} e^{-i\omega t} dt \end{aligned} \quad (3-728)$$

If we change the variable of integration from t to

$$\lambda = v_0 t - x_i \quad (3-729)$$

then we have

$$\begin{aligned} \frac{1}{2\pi} \int_{-\infty}^{\infty} \{ f(v_0 t - x_i) \} e^{-i\omega t} dt &= \frac{1}{2\pi} \int_{-\infty}^{\infty} \{ f(\lambda) e^{-i\frac{\omega}{v_0} x_i} \} e^{-i\frac{\omega}{v_0} \lambda} \frac{d\lambda}{v_0} \\ &= \frac{1}{v_0} \{ e^{-i\frac{\omega}{v_0} x_i} \} \frac{1}{2\pi} \int_{-\infty}^{\infty} f(\lambda) e^{-i\frac{\omega}{v_0} \lambda} d\lambda \end{aligned} \quad (3-730)$$

Now, in this expression, we recognize the Fourier transform of the special distribution of fluid velocities based on the "special" frequency

$$\Omega = \frac{\omega}{v_0} \quad (3-731)$$

That is

$$\bar{f}(\Omega) = \frac{1}{2\pi} \int_{-\infty}^{\infty} f(\lambda) e^{-i\Omega \lambda} d\lambda \quad (3-732)$$

We then have

$$\{ \bar{Q}(\omega) \} = \frac{\rho_0}{2} [\varphi]'[\Lambda] \{ e^{-i\frac{\omega}{v_0} x_i} \} \bar{f}(\Omega) \quad (3-733)$$

We have the theorem¹ that any variable linearly related to $\bar{F}(\Omega)$, say

$$\bar{q}(\omega) = \tau(\omega) \bar{f}(\Omega) \quad (3-734)$$

¹ See Truxal, John G., Control System Synthesis, McGraw-Hill, 1955, Chaps. 7 and 8 in particular, equation 8.3, p. 455.

has a power spectrum given by

$$\Phi[q(t); \omega] = |T(\omega)|^2 \Phi[f(\lambda); \Omega] \quad (3-735)$$

Using Equations 3-727 and 3-733, we obtain

$$\begin{aligned} \{\bar{q}(\omega)\} &= \left(-\left(\frac{\omega}{V_0}\right)^2 [M] + \frac{1}{V_0^2} [F] + \frac{\rho_0}{2} [C_R] + i\frac{\omega}{V_0} \frac{\rho_0}{2} [C_I] \right)^{-1} \\ &\quad \frac{\rho_0}{2V_0^2} [\varphi] [\Lambda] e^{-i\frac{\omega}{V_0} x_i} \bar{f}\left(\frac{\omega}{V_0}\right) \end{aligned} \quad (3-736)$$

The loads equations (3-714) in the frequency domain are

$$\begin{aligned} \{\bar{F}(\omega)\} &= \left(-\omega^2 [A] + \frac{\rho_0 V_0^2}{2} ([\Lambda] [\Delta] + i\frac{\omega}{V_0} [\Lambda]) \right) \{\bar{P}(\omega)\} \\ &\quad + \frac{\rho_0}{2} [\Lambda] e^{-i\frac{\omega}{V_0} x_i} \bar{f}(\Omega) \end{aligned} \quad (3-737)$$

For the purpose of being specific let us take the bending moment at the center of mass, $x = \bar{x}$, as a typical load

$$\begin{aligned} M(t) &= \{\bar{x} \quad \bar{x} - x_1 \dots \bar{x} - x_i \quad 0, 0, \dots, 0\} \{F(t)\} \\ &= \{R\}' \{F(t)\} \end{aligned} \quad (3-738)$$

Making use of

$$\{\bar{P}(\omega)\} = [\varphi] \{\bar{q}(\omega)\} \quad (3-739)$$

and Equation 3-737, we obtain

$$\begin{aligned} \bar{M}(\omega) &= \{R\}' \left(\left(-\left(\frac{\omega}{V_0}\right)^2 [A] + \frac{\rho_0}{2} ([\Lambda] [\Delta] + i\frac{\omega}{V_0} [\Lambda]) \right) [\varphi] \right. \\ &\quad \left. \left(-\left(\frac{\omega}{V_0}\right)^2 [M] + \frac{1}{V_0^2} [F] + \frac{\rho_0}{2} [C_R] + i\frac{\omega}{V_0} \frac{\rho_0}{2} [C_I] \right)^{-1} [\varphi] \right. \\ &\quad \left. + [1] \right) \frac{\rho_0}{2} [\Lambda] e^{-i\frac{\omega}{V_0} x_i} \bar{f}\left(\frac{\omega}{V_0}\right) \end{aligned} \quad (3-740)$$

which we can write as

$$\bar{M}(\omega) = T(\omega) \bar{f}\left(\frac{\omega}{V_0}\right) \quad (3-741)$$

Contrails

where

$$T(\omega) = \{R\} \left((-\frac{\omega}{V_0})^2 [A] + \frac{1}{2} [\Lambda][\Delta] + i(\frac{\omega}{V_0}) [A] \right) \cdot \quad (3-742)$$

$$\cdot [\varphi] \left(-(\frac{\omega}{V_0})^2 [M] + \frac{1}{2} [F] + \frac{1}{2} [C_R] + i(\frac{\omega}{V_0}) [C_I] \right) [\varphi]^T$$

$$+ T_{1j} \int_0^L [\Lambda] \{ e^{-i\frac{\omega}{V_0} x} \}$$

The power spectral density of the bending moment is given by

$$\Phi [M(t); \omega] = |T(\omega)|^2 \left(\sigma^2 \frac{L}{\pi} \frac{1 + 3(\frac{\omega}{V_0})^2 L^2}{(1 + (\frac{\omega}{V_0})^2 L^2)^2} \right) \quad (3-743)$$

where use has been made of Equations 3-706 and 3-735. The above procedure is typical for finding the transfer function of any aeroelastic variable that is important to the design of a missile for strength and/or low cycle fatigue considerations.

ACCELERATION OF
CENTER OF MASS

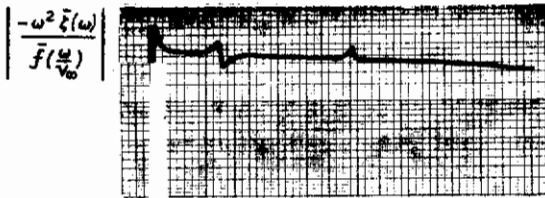

RIGID BODY PITCH

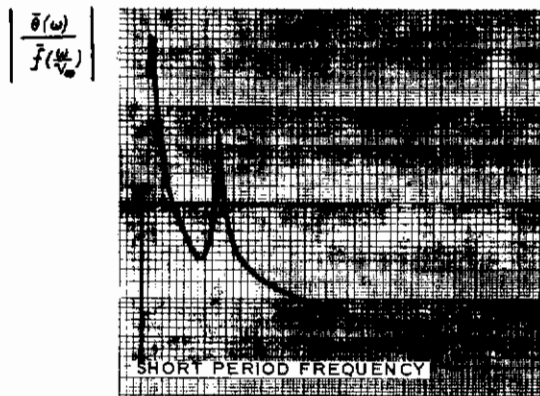

FIRST ELASTIC MODE

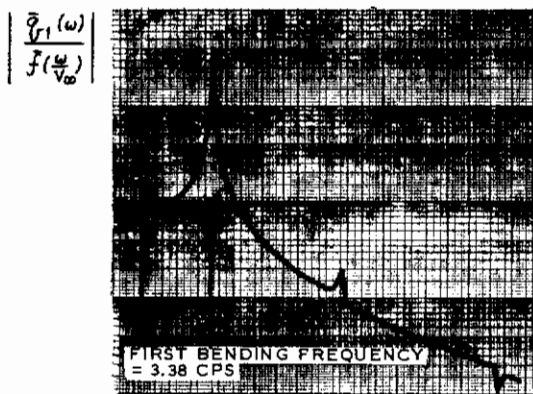

SECOND ELASTIC MODE

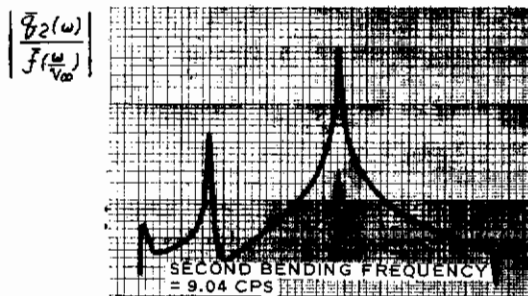

BENDING MOMENT AT
THE CENTER OF MASS

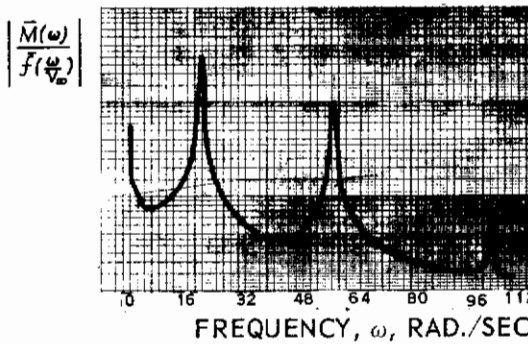

FIGURE 55 TRANSFER FUNCTIONS FOR ATMOSPHERIC TURBULENCE

3.1.5 Dynamic Loads during Ground Transportation

The results of this section are more specialized in their application than the results of the previous sections, but this section is included to illustrate further the applications of the general methods of Section 2.0 to a wide variety of structural dynamics problems.

The specific problem considered is described by Figure 56. The system is assumed to be a flexible launch vehicle supported on three shock mounts by a rigid trailer. The rigid body motion of the trailer is assumed to be known as a function of time. The shock mounts are idealized by a linear spring and a linear dashpot in parallel as shown by Figure 57.

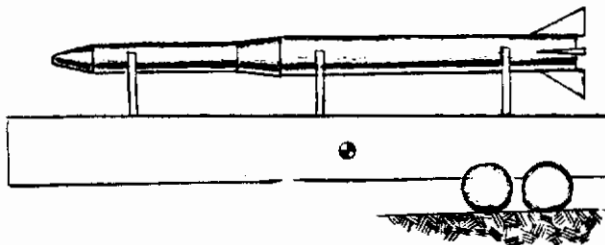

FIGURE 56 MISSILE TRANSPORTER SYSTEM

In terms of a number of collocation point displacements on the missile, we have

$$T = \frac{1}{2} \{\dot{p}\}' [A] \{p\} \tag{3-744}$$

$$R = \frac{1}{2} \{p\}' [B] \{p\} \tag{3-745}$$

and

$$U = \frac{1}{2} \{p\}' [K] \{p\} \tag{3-746}$$

where $[K]$ is the stiffness matrix for the unrestrained launch vehicle and $[B]$ is the unrestrained damping matrix¹.

¹In most cases, damping in the vehicle structure can be described adequately by $[B] = \beta [K]$. See Also Paragraph 3.1.3.7.1.

Contrails

The extension of the i^{th} spring is

$$\underbrace{\dot{J} + (\bar{x} - x_i)\dot{\theta}}_{\text{displacement of lower end}} - \underbrace{p_z(x_i, t)}_{\text{displacement of upper end}}$$

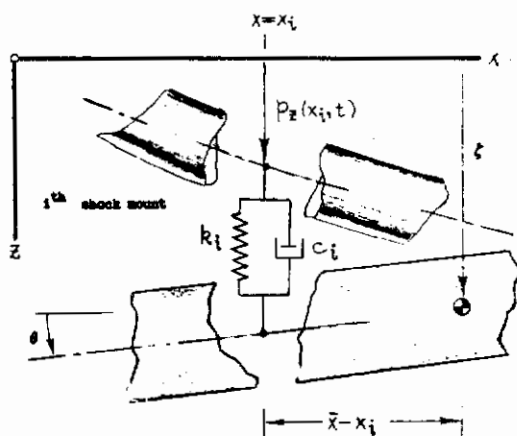

FIGURE 57 IDEALIZATION OF SHOCK MOUNT

The displacement, ζ , and rotation, θ , of the trailer are assumed to be known functions of time.

The force, N_i , that the i^{th} shock mount exerts on the missile in the z -direction is given by

$$N_i = k_i \left(\dot{J} + (\bar{x} - x_i)\dot{\theta} - p_z(x_i, t) \right) + c_i \left(\dot{J} + (\bar{x} - x_i)\dot{\theta} - \frac{\partial p_z}{\partial t}(x_i, t) \right) \quad (3-747)$$

Contrails

where k_i and c_i are the spring and damping constants. The total virtual work of these forces is

$$\delta W = \sum_{i=1}^M \delta p_z(x_i, t) N_i \quad (3-748)$$

for M different shock mounts.

The missile displacement is related to the generalized coordinates by a relation of the form:

$$p_z(x_i, t) = \{h_z(x)\}' \{p\} \quad (3-749)$$

Using this in Equations 3-747 and 3-748, we obtain

$$\begin{aligned} \delta W = \{ \delta p \}' \sum_{i=1}^M \{ h_z(x_i) \}' k_i \left(\int + (\bar{x} - x_i) \theta - \{ h_z(x_i) \}' \{ p \} \right) \\ + \{ h_z(x_i) \}' c_i \left(\dot{\int} + (\bar{x} - x_i) \dot{\theta} - \{ h_z(x_i) \}' \{ \dot{p} \} \right) \end{aligned} \quad (3-750)$$

If we use

$$1 = \{ h_z(x) \}' \{ 1 \} \quad (3-751)$$

$$\bar{x} - x = \{ h_z(x) \}' \{ \bar{x} - x \} \quad (3-752)$$

and introduce

$$[K_S] = \sum_{i=1}^M \{ h_z(x_i) \}' \{ h_z(x_i) \}' k_i \quad (3-753)$$

$$[B_S] = \sum_{i=1}^M \{ h_z(x_i) \}' \{ h_z(x_i) \}' c_i \quad (3-754)$$

we can write Equation 3-750 as

$$\begin{aligned} \delta W = \{ \delta p \}' [K_S] \left(\{ 1 \}' \int + \{ \bar{x} - x \}' \theta - \{ p \} \right) \\ + \{ \delta p \}' [B_S] \left(\{ 1 \}' \dot{\int} + \{ \bar{x} - x \}' \dot{\theta} - \{ \dot{p} \} \right) \end{aligned} \quad (3-755)$$

In order to reduce the number of degrees-of-freedom, it is expedient to transform to modal generalized coordinates. For this purpose, we introduce

$$\{ p \} = [\phi] H q \quad (3-756)$$

where $[\phi]$ is a matrix of unrestrained modes for the launch vehicle (including rigid-body modes). Substituting Equation 3-756 into Equations 3-744, 3-745, 3-746, and 3-755, gives

$$T = \frac{1}{2} \{ \dot{q} \}' [\phi]' [A] [\phi] H \dot{q} \quad (3-757)$$

$$U = \frac{1}{2} \{ q \}' [\phi]' [K] [\phi] H q \quad (3-758)$$

Contrails

$$R = \frac{1}{2} \{ \ddot{q}_j \}' [\varphi]' [B] [\varphi] \{ \dot{q}_j \} \quad (3-759)$$

$$\begin{aligned} \delta W = & - \{ \delta q_j \}' [\varphi]' [K_s] [\varphi] \{ q_j \} - \{ \delta q_j \}' [\varphi]' [B_s] [\varphi] \{ \dot{q}_j \} \\ & + \{ \delta q_j \}' \left([\varphi]' [K_s] \{ j \} \dot{r} + [\varphi]' [K_s] \{ \bar{x} - x \} \dot{\theta} \right. \\ & \left. + [\varphi]' [B_s] \{ j \} \dot{r} + [\varphi]' [K_s] \{ \bar{x} - x \} \dot{\theta} \right) \end{aligned} \quad (3-760)$$

Lagrange's equations (Equations (2-64)) are

$$\frac{d}{dt} \frac{\partial I}{\partial \dot{q}_i} - \frac{\partial I}{\partial q_i} + \frac{\partial U}{\partial q_i} + \frac{\partial R}{\partial \dot{q}_i} = Q_i \quad (3-761)$$

where

$$\delta W = \sum_i \delta q_i Q_i \quad (3-762)$$

and, in the present case, these equations yield

$$\begin{aligned} [M] \{ \ddot{q}_j \} + [R] \{ \dot{q}_j \} + [F] \{ q_j \} \\ = [\varphi]' [K_s] \{ j \} \dot{r}(t) + [\varphi]' [K_s] \{ \bar{x} - x \} \dot{\theta}(t) \\ + [\varphi]' [B_s] \{ j \} \dot{r}(t) + [\varphi]' [B_s] \{ \bar{x} - x \} \dot{\theta}(t) \end{aligned} \quad (3-763)$$

where

$$[M] = [\varphi]' [A] [\varphi] \quad (3-764)$$

$$[R] = [\varphi]' [B] [\varphi] + [\varphi]' [B_s] [\varphi] \quad (3-765)$$

$$[F] = [\varphi]' [K] [\varphi] + [\varphi]' [K_s] [\varphi] \quad (3-766)$$

These equations may be put in the form

$$[M] \{ \ddot{q}_j \} + [R] \{ \dot{q}_j \} + [F] \{ q_j \} = \left[\frac{\partial Q}{\partial F} \right] \{ F(t) \} \quad (3-767)$$

where

$$\left[\frac{\partial Q}{\partial F} \right] = \begin{bmatrix} [\varphi]' [K_s] \{ j \} \dot{r}, & [\varphi]' [K_s] \{ \bar{x} - x \} \dot{\theta} \\ [\varphi]' [B_s] \{ j \} \dot{r}, & [\varphi]' [B_s] \{ \bar{x} - x \} \dot{\theta} \end{bmatrix} \quad (3-768)$$

and

$$\{ F(t) \} = \begin{bmatrix} \dot{r}(t) \\ \dot{\theta}(t) \\ \dot{r}(t) \\ \dot{\theta}(t) \end{bmatrix} \quad (3-769)$$

Contrails

These equations can be solved by the general program mentioned in the second part of Appendix VI.

The transient shears and bending moments on the vehicle are determined from (see also Paragraph 5.1.1.1, Equation 5-54).

$$\{F\} = [K]H\{\dot{p}\} + [B]H\{\ddot{p}\} \quad (3-770)$$

$$V_i = \sum_{j < i} F_j \quad (3-771)$$

$$M_i = \sum_{j < i} (x_i - x_j) F_j \quad (3-772)$$

The force in the i^{th} shock mount is given by Equation 3-747

$$N_i = k_i \{h_{z_i}(x_i)\}' (\{i\}\dot{s} + \{\bar{x} - x\}\dot{\theta} - \{\dot{p}\}) + c_i \{h_{z_i}(x_i)\}' (\{i\}\ddot{s} + \{\bar{x} - x\}\ddot{\theta} - \{\ddot{p}\}) \quad (3-773)$$

From Lagrange's equations for the coordinates, p_1 , we can obtain

$$\begin{aligned} [K]H\{\dot{p}\} + [B]H\{\ddot{p}\} &= - [A]I\varphi H\{\ddot{q}\} + [K_s]H\{\dot{s}\} + [K_s]H\{\bar{x} - x\}\dot{\theta} \\ &\quad + [B_s]H\{\dot{s}\} + [B_s]H\{\bar{x} - x\}\dot{\theta} \\ &\quad - [K_s]I\varphi H\{\dot{q}\} - [B_s]I\varphi H\{\ddot{q}\} \end{aligned} \quad (3-774)$$

If we introduce a matrix of all the internal loads (shears, bending moments, and shock mount forces) defined by

$$\{L\} = \begin{bmatrix} V_1 \\ V_2 \\ \vdots \\ M_1 \\ M_2 \\ \vdots \\ N_1 \\ N_2 \\ \vdots \end{bmatrix} \quad (3-775)$$

then we can express Equations 3-771, 3-772, and 3-773 in the form

$$\begin{aligned} \{L\} &= \left[\frac{\partial L}{\partial F} \right] \{F(t)\} + \left[\frac{\partial L}{\partial \dot{q}} \right] H\{\ddot{q}\} + \left[\frac{\partial L}{\partial \dot{q}} \right] H\{\dot{q}\} \\ &\quad + \left[\frac{\partial L}{\partial q} \right] H\{q\} \end{aligned} \quad (3-776)$$

where, as before

$$\{F(t)\} = \begin{bmatrix} s(t) \\ \theta(t) \\ \dot{s}(t) \\ \dot{\theta}(t) \end{bmatrix} \quad (3-777)$$

The transient loads, expressed in the form of Equation 3-776 can be calculated along with the integration of Equation 3-763 as discussed in the second part of Appendix VI.

3.2 THE NONLINEAR AEROELASTIC EQUATIONS GOVERNING THE PLANE MOTION OF A FLEXIBLE MISSILE EXECUTING ARBITRARILY LARGE "RIGID-BODY" DISPLACEMENTS

The motivation for including the nonlinearities associated with large displacements of a slender missile stems from the need for calculating the trajectory simultaneously with the calculations of loads (shears and bending moments). In this section, only plane motion is considered; these concepts serve as an introduction to Section 4.0, where the general case is treated.

3.2.1 The Kinematics of the Plane Motion of a Flexible Missile

The geometry of the system considered is shown in Figure 58.

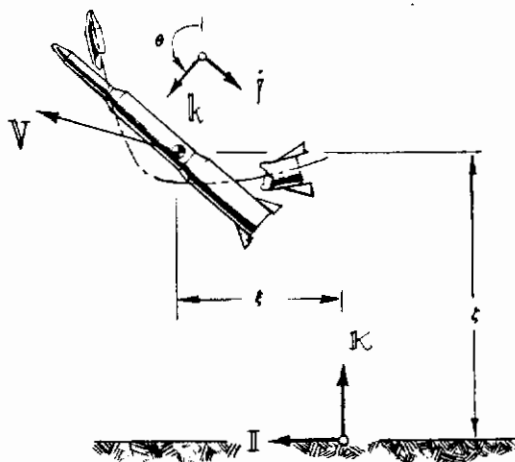

FIGURE 58 INERTIAL AND BODY REFERENCE SYSTEMS

The relation between the two reference systems is given by

$$i = \cos\theta I - \sin\theta K \quad (3-778)$$

$$k = \sin\theta I + \cos\theta K \quad (3-779)$$

from which

$$\frac{d\dot{v}}{dt} = -\dot{\theta}k \quad (3-780)$$

$$\frac{d\dot{k}}{dt} = \dot{\theta}\dot{v} \quad (3-781)$$

The position vector for the x-y-z particle is given by

$$r(x, y, z, t) = R(t) + (x-\bar{x})\dot{v} + y\dot{j} + (z-\bar{z})\dot{k} + p(x, y, z, t) \quad (3-782)$$

where R is the position vector for the center-of-mass of the body.

$$R(t) = \frac{\iiint m(x, y, z, t) \rho(x, y, z) dx dy dz}{\iiint \rho(x, y, z) dx dy dz} = \xi(t)I + \eta(t)K \quad (3-783)$$

and \bar{x} , \bar{z} are defined by

$$\bar{x} = \frac{\iiint x \rho(x, y, z) dx dy dz}{\iiint \rho(x, y, z) dx dy dz} \quad (3-784)$$

$$\bar{z} = \frac{\iiint z \rho(x, y, z) dx dy dz}{\iiint \rho(x, y, z) dx dy dz} \quad (3-785)$$

$\xi(t)$ and $\eta(t)$ are the components of $R(t)$ resolved in the ground (inertial) reference system. The displacement of particles relative to the $(\dot{v}, \dot{j}, \dot{k})$ "body" reference system is described by $p(x, y, z, t)$. It may be noted that $(\bar{x}, 0, \bar{z})$ are the Lagrangian coordinates of the particle which is at the center-of-mass of the undeformed body.

The velocity of the x-y-z particle is given by

$$\begin{aligned}
 \mathcal{V}(x, y, z, t) &= \frac{\partial \mathcal{H}}{\partial \dot{t}}(x, y, z, t) \\
 &= \frac{dR}{dt} + (x-\bar{x})\frac{d\dot{y}}{dt} + y\frac{d\dot{x}}{dt} + (z-\bar{z})\frac{dk}{dt} + \frac{\partial \mathcal{P}}{\partial \dot{t}} \\
 &= \frac{dR}{dt} - (x-\bar{x})\dot{\theta}k + (z-\bar{z})\dot{\theta}i + \frac{\partial \mathcal{P}}{\partial \dot{t}}
 \end{aligned}
 \tag{3-786}$$

The displacement resolved in the body reference is

$$\mathcal{P}(x, z, t) = p_x(x, z, t)\dot{y} + p_z(x, z, t)k
 \tag{3-787}$$

so that

$$\frac{\partial \mathcal{P}}{\partial \dot{t}} = \frac{\partial p_x}{\partial \dot{t}}\dot{y} + \frac{\partial p_z}{\partial \dot{t}}k - p_x\dot{\theta}k + p_z\dot{\theta}i
 \tag{3-788}$$

If we denote the velocity of the center-of-mass by \mathcal{V} , then

$$\frac{dR}{dt} = \mathcal{V}
 \tag{3-789}$$

and

$$\begin{aligned}
 \mathcal{V}(x, y, z, t) &= \mathcal{V}(t) + ((z-\bar{z})\dot{\theta} + p_z\dot{\theta} + \frac{\partial p_x}{\partial \dot{t}})\dot{y} \\
 &\quad - ((x-\bar{x})\dot{\theta} + p_x\dot{\theta} - \frac{\partial p_z}{\partial \dot{t}})k
 \end{aligned}
 \tag{3-790}$$

3.2.2 The Kinetic Energy

The kinetic energy of the body is

Contrails

$$\begin{aligned}
 T &= \frac{1}{2} \int \left(\frac{\partial \mathbf{u}}{\partial t} \right)^2 \rho dV \\
 &= \frac{1}{2} \iiint \mathbf{v} \cdot \mathbf{v} \rho(x, y, z) dx dy dz
 \end{aligned}
 \tag{3-791}$$

From Equation 3-790

$$\begin{aligned}
 \mathbf{v} \cdot \mathbf{v} &= V^2 + 2\mathbf{V} \cdot \dot{\mathbf{i}} \left(\frac{\partial p_x}{\partial t} + (z-\bar{z})\dot{\theta} + p_z\dot{\theta} \right) \\
 &\quad + 2\mathbf{V} \cdot \dot{\mathbf{k}} \left(\frac{\partial p_z}{\partial t} - (x-\bar{x})\dot{\theta} - p_x\dot{\theta} \right) \\
 &\quad + \left(\frac{\partial p_x}{\partial t} + (z-\bar{z})\dot{\theta} + p_z\dot{\theta} \right)^2 + \left(\frac{\partial p_z}{\partial t} - (x-\bar{x})\dot{\theta} - p_x\dot{\theta} \right)^2
 \end{aligned}
 \tag{3-792}$$

In order to separate the "rigid-body" and "elastic" motion we will impose the following constraints on the displacement relative to the body-axis reference system:

$$\iiint \rho(x, z, t) \rho(x, y, z) dx dy dz = 0
 \tag{3-793}$$

$$\iiint (x-\bar{x})\dot{\mathbf{i}} + y\dot{\mathbf{j}} + (z-\bar{z})\dot{\mathbf{k}} \times \rho(x, z, t) \rho(x, y, z) dx dy dz = 0
 \tag{3-794}$$

The first condition is always true when \mathbf{R} is the position vector to the true center-of-mass for the deformed body. The motive for imposing the second condition is not basic and any further discussion will have to be deferred to Section 4.0 (see Equation 4-18). Equation 3-794 is the "second-moment" of ρ in the same sense that Equation 3-793 is the "first-moment" of ρ .

The scalar equations corresponding to Equations 3-793 and 3-794 are

$$\iiint p_x(x, z, t) \rho(x, y, z) dx dy dz = 0
 \tag{3-795}$$

Contrails

$$\iiint p_z(x, z, t) \rho(x, y, z) dx dy dz = 0 \quad (3-796)$$

$$\iiint ((x-\bar{x})p_z - (z-\bar{z})p_x) \rho(x, y, z) dx dy dz = 0 \quad (3-797)$$

By differentiating these expressions, we also have:

$$\iiint \frac{\partial p_x}{\partial t}(x, z, t) \rho(x, y, z) dx dy dz = 0 \quad (3-798)$$

$$\iiint \frac{\partial p_z}{\partial t}(x, z, t) \rho(x, y, z) dx dy dz = 0 \quad (3-799)$$

$$\iiint (x-\bar{x}) \frac{\partial p_z}{\partial t} \rho(x, y, z) dx dy dz - \iiint (z-\bar{z}) \frac{\partial p_x}{\partial t} \rho(x, y, z) dx dy dz = 0 \quad (3-800)$$

Substituting Equation 3-787 into Equation 3-786 using Equations 3-795 through 3-800, we obtain

$$\begin{aligned} T = & \frac{1}{2} (\cdot V^2 \iiint \rho dx dy dz + \dot{\Theta}^2 \iiint ((z-\bar{z})^2 + (x-\bar{x})^2) \rho dx dy dz \\ & + 2\dot{\Theta}^2 \iiint ((z-\bar{z})p_z + (x-\bar{x})p_x) \rho dx dy dz \\ & + \dot{\Theta}^2 \iiint (p_x^2 + p_z^2) \rho dx dy dz \\ & + 2\dot{\Theta} \iiint (p_z \frac{\partial p_x}{\partial t} - p_x \frac{\partial p_z}{\partial t}) \rho dx dy dz \\ & + \iiint ((\frac{\partial p_x}{\partial t})^2 + (\frac{\partial p_z}{\partial t})^2) \rho dx dy dz \end{aligned} \quad (3-801)$$

We can resolve \mathbf{V} in the body reference

$$\mathbf{V} = V_x \hat{i} + V_z \hat{k} \quad (3-802)$$

and we recognize the total mass,

$$M = \iiint \rho \, dx \, dy \, dz \quad (3-803)$$

and the total "pitch" moment of inertia about the center of mass of the undeformed body

$$I = \iiint ((z-\bar{z})^2 + (x-\bar{x})^2) \rho \, dx \, dy \, dz \quad (3-804)$$

The kinetic energy is then

$$\begin{aligned} T = & \frac{1}{2} \left(M V_x^2 + M V_z^2 + I \dot{\theta}^2 + 2 \dot{\theta}^2 \iiint ((z-\bar{z}) p_z + (x-\bar{x}) p_x) \rho \, dx \, dy \, dz \right. \\ & + \dot{\theta}^2 \iiint (p_x^2 + p_z^2) \rho \, dx \, dy \, dz \\ & \left. + 2 \dot{\theta} \iiint (p_z \frac{\partial p_x}{\partial t} - p_x \frac{\partial p_z}{\partial t}) \rho \, dx \, dy \, dz \right. \\ & \left. + \iiint \left(\left(\frac{\partial p_x}{\partial t} \right)^2 + \left(\frac{\partial p_z}{\partial t} \right)^2 \right) \rho \, dx \, dy \, dz \right) \quad (3-805) \end{aligned}$$

3.2.3 The Approximation of a Finite Number of Degrees-of-Freedom

In order to obtain a rational solution to the general problem, we make a finite degree-of-freedom approximation (see Equations 2-361, 2-363 and also 2-451 in Section 2.3).

Contrails

$$p_x(x, z, t) = \sum_{i=1}^N h_x^{(i)}(x, z) p_i(t) = \{h_x\}' \{p\} \quad (3-806)$$

$$p_z(x, z, t) = \sum_{i=1}^N h_z^{(i)}(x, z) p_i(t) = \{h_z\}' \{p\} \quad (3-807)$$

Rigid body displacements relative to the body reference system are given by

$$p_x = 1 = \{h_x\}' \{\varphi_R\}_1 \quad (3-808)$$

$$p_z = 0 = \{h_z\}' \{\varphi_R\}_1 \quad (3-809)$$

$$p_x = 0 = \{h_x\}' \{\varphi_R\}_2 \quad (3-810)$$

$$p_z = 1 = \{h_z\}' \{\varphi_R\}_2 \quad (3-811)$$

$$p_x = (z - \bar{z}) = \{h_x\}' \{\varphi_R\}_3 \quad (3-812)$$

$$p_z = (x - \bar{x}) = \{h_z\}' \{\varphi_R\}_3 \quad (3-813)$$

Using these relations we can express the terms in the kinetic energy in terms of the generalized coordinates, p_1 .

$$\iiint p_x^2 \rho dx dy dz = \{p\}' \iiint \{h_x\} \{h_x\}' \rho dx dy dz \{p\} \quad (3-814)$$

$$\iiint p_z^2 \rho dx dy dz = \{p\}' \iiint \{h_z\} \{h_z\}' \rho dx dy dz \{p\} \quad (3-815)$$

$$\iiint p_x \frac{\partial p_z}{\partial t} \rho dx dy dz = \{p\}' \iiint \{h_x\} \{h_z\}' \rho dx dy dz \{\dot{p}\} \quad (3-816)$$

$$\iiint p_z \frac{\partial p_x}{\partial t} \rho dx dy dz = \{p\}' \iiint \{h_z\} \{h_x\}' \rho dx dy dz \{\dot{p}\} \quad (3-817)$$

Contrails

$$\iiint (\bar{x} - \bar{x}) \dot{p}_z \rho dx dy dz = -\{\varphi_R\}'_3 \iiint \{h_x\} \{h_z\}' \rho dx dy dz \{\dot{p}\} \quad (3-818)$$

$$\iiint (\bar{x} - \bar{x}) \dot{p}_x \rho dx dy dz = -\{\varphi_R\}'_3 \iiint \{h_z\} \{h_x\}' \rho dx dy dz \{\dot{p}\} \quad (3-819)$$

$$\iiint \left(\frac{\partial \dot{p}_x}{\partial t}\right)^2 \rho dx dy dz = \{\dot{p}\}' \iiint \{h_x\} \{h_x\}' \rho dx dy dz \{\dot{p}\} \quad (3-820)$$

$$\iiint \left(\frac{\partial \dot{p}_z}{\partial t}\right)^2 \rho dx dy dz = \{\dot{p}\}' \iiint \{h_z\} \{h_z\}' \rho dx dy dz \{\dot{p}\} \quad (3-821)$$

These equations can be simplified if we introduce

$$[A_{xx}] = \iiint \{h_x\} \{h_x\}' \rho dx dy dz \quad (3-822)$$

$$[A_{zz}] = \iiint \{h_z\} \{h_z\}' \rho dx dy dz \quad (3-823)$$

$$[A_{xz}] = \iiint \{h_x\} \{h_z\}' \rho dx dy dz \quad (3-824)$$

and the kinetic energy can be written as

$$\begin{aligned} T = & \frac{1}{2} (MV_x^2 + MV_z^2 + I\dot{\theta}^2 \\ & 2\dot{\theta}^2 \{\varphi_R\}'_3 ([A_{xz}] - [A_{xz}]') \{\dot{p}\} \\ & + \dot{\theta}^2 \{\dot{p}\}' ([A_{xx}] + [A_{zz}]) \{\dot{p}\} \\ & - 2\dot{\theta} \{\dot{p}\}' ([A_{xz}] - [A_{xz}]') \{\dot{p}\} \\ & + \{\dot{p}\}' ([A_{xx}] + [A_{zz}]) \{\dot{p}\}) \end{aligned} \quad (3-825)$$

Contrails

We can further introduce

$$[A] = [A_{xx}] + [A_{zz}] \quad (3-826)$$

$$[G] = \frac{[A_{xz}] - [A_{xz}]'}{2} \quad (3-827)$$

and note that

$$[A] = [A]' \quad (3-828)$$

and

$$[G] = -[G]' \quad (3-829)$$

so that $[A]$ is symmetric and $[G]$ is anti-symmetric.

Using Equations 3-808 through 3-813, it can be shown that

$$M = \{\psi_R\}'_1 [A] \{\psi_R\}_1 = \{\psi_R\}'_2 [A] \{\psi_R\}_2 \quad (3-830)$$

$$I = \{\psi_R\}'_3 [A] \{\psi_R\}_3 \quad (3-831)$$

It is fairly evident that the $[A]$ matrix is the inertia matrix of small vibration theory (see Equation 2-132 or Section 2.2).

The final expression for the kinetic energy is

$$\begin{aligned}
 T = & \frac{1}{2} MV_x^2 + \frac{1}{2} MV_z^2 \\
 & + \frac{1}{2} (I + \{p\}'[A]H\{p\} + 4\{p_R\}'[G]H\{p\}) \Omega_y^2 \\
 & + 2 \{p\}'[G]H\{p\} \Omega_y \\
 & + \frac{1}{2} \{p\}'[A]H\{p\}
 \end{aligned} \tag{3-832}$$

where we have introduced $\Omega_y = \dot{\theta}$.

3.2.4 The Strain Energy and the Virtual Work of External Forces

The strain energy of the system is assumed to be of the form

$$U = \frac{1}{2} \{p\}'[K]H\{p\} + \frac{1}{2} \{p\}'[N]H\{p\} \tag{3-833}$$

where the second term is the contribution to the strain energy from "column" loading (see Paragraph 3.1.2.5, Equation 3-197). The strains in the body are assumed to be independent of the "rigid-body" coordinates, ξ , ζ , θ ; so that the discussion of the strain energy in Section 3.1 applies here as well.

The damping in the structure is described by Rayleigh's dissipation function:

$$R = \frac{1}{2} \{\dot{p}\}'[B]H\{\dot{p}\} \tag{3-834}$$

External forces are introduced in the virtual work of these forces

$$\delta w = \{\delta p\}'\{P\} + \delta \xi Z + \delta \zeta Z + \delta \theta \Theta \tag{3-835}$$

which defines the generalized forces associated with the generalized coordinates, p_i , ξ , ζ , and θ .

The generalized coordinates, p_i , are subject to the following constraints:

$$F_1 = \{\varphi_R\}_1^T [A] \{\dot{p}\} = 0 \quad (3-836)$$

$$F_2 = \{\varphi_R\}_2^T [A] \{\dot{p}\} = 0 \quad (3-837)$$

$$F_3 = \{\varphi_R\}_3^T [A] \{\dot{p}\} = 0 \quad (3-838)$$

which follow from Equations 3-795, 3-796, and 3-797.

3.2.5 The Equations for Transient Loads

The equations for determining transient loads are derived from the Lagrange equations corresponding to p_1, p_2, \dots, p_N . From Equation 2-79 of Paragraph 2.1.2.2, we have

$$\frac{d}{dt} \left(\frac{\partial \pi}{\partial \dot{p}_i} \right) - \frac{\partial \pi}{\partial p_i} + \frac{\partial U}{\partial p_i} + \frac{\partial R}{\partial p_i} = \sum_{j=1}^3 \frac{\partial E_j}{\partial p_i} \lambda_j + P_i \quad (3-839)$$

Using Equations 3-833 through 3-838, we obtain

$$\begin{aligned} & [A] \ddot{\{p\}} + 2\dot{\omega}_y [G] \dot{\{p\}} + \omega_y^2 [G] \{\dot{p}\} \\ & \quad - \omega_y^2 [A] \{\dot{p}\} + 2\dot{\omega}_y^2 [G] \{H\varphi_R\}_3 \\ & \quad + [K] \{\dot{p}\} + [N] \{p\} + [B] \dot{\{p\}} \\ & = [A] \{H\varphi_R\}_1 \lambda_1 + [A] \{H\varphi_R\}_2 \lambda_2 + [A] \{H\varphi_R\}_3 \lambda_3 \\ & \quad + \{P\} \end{aligned} \quad (3-840)$$

Contrails

Because of the relations

$$[K]\{\varphi_R\}_i = \{0\} \quad (3-841)$$

and

$$[B]\{\varphi_R\}_i = \{0\} \quad (3-842)$$

we may eliminate the multipliers λ_1 , λ_2 , and λ_3 (see Paragraph 2.2.3.4, Equation 2-271). Then

$$\begin{aligned} & [KH\dot{p}] + [BH\dot{p}] \\ & = - [\Gamma] \left([A]\ddot{p} + 2\dot{\Omega}_y [G]\dot{p} + 4\Omega_y [G]H\dot{p} \right. \\ & \quad \left. - \Omega_y^2 [A]H\dot{p} + 2\Omega_y^2 [G]H\varphi_{R3} + [N]H\dot{p} - \{P\} \right) \end{aligned} \quad (3-843)$$

where

$$[\Gamma] = [1] - [A][\varphi_R]([\varphi_R]'[A][\varphi_R])^{-1}[\varphi_R]' \quad (3-844)$$

and

$$[\varphi_R] = [\{\varphi_{R1}, \{\varphi_{R2}, \{\varphi_{R3}\}] \quad (3-845)$$

The structural loads (shears and bending moments) can be related to the effective loads,

$$[KH\dot{p}] + [BH\dot{p}]$$

by a transformation, $[R]$, like the one considered in Paragraph 3.1.2.1, Equation 3-79. If we denote the shears, bending moments, and any other pertinent stress resultants by L_1 , then

$$\{L\} = [R]([K]H\dot{p}\dot{\} + [B]H\ddot{p}\ddot{\}) \quad (3-846)$$

or

$$\begin{aligned} \{L\} = [R][\Gamma] & \left(\{P\} - [A]H\ddot{p}\ddot{\} - 2\dot{\omega}_y [G]H\dot{p}\dot{\} \right. \\ & \left. - 4\dot{\omega}_y [G]H\ddot{p}\ddot{\} + \dot{\omega}_y^2 [A]H\dot{p}\dot{\} \right. \\ & \left. - 2\dot{\omega}_y^2 [G]H\psi_R\dot{\} - [N]H\dot{p}\dot{\} \right) \quad (3-847) \end{aligned}$$

3.2.6 The Equations for the Trajectory

The equations for determining the trajectory are derived from Lagrange's equations corresponding to the generalized coordinates, ξ , ζ , and θ .

$$\frac{d}{dt} \left(\frac{\partial T}{\partial \dot{\xi}} \right) - \frac{\partial T}{\partial \xi} = \tilde{Z} \quad (3-848)$$

$$\frac{d}{dt} \left(\frac{\partial T}{\partial \dot{\zeta}} \right) - \frac{\partial T}{\partial \zeta} = Z \quad (3-849)$$

$$\frac{d}{dt} \left(\frac{\partial T}{\partial \dot{\theta}} \right) - \frac{\partial T}{\partial \theta} = \Theta \quad (3-850)$$

Contrails

Because the kinetic energy (Equation 3-832) is expressed in terms of V_x , V_z , and Ω_y , it will be convenient to replace the above equations by a set of Lagrange equations for quasi-coordinates (see Paragraph 2.1.2.3).

From the relation,

$$V = \frac{dR}{dt} = V_x \dot{\eta} + V_z \dot{\kappa} - \dot{\xi} I + \dot{j} K \quad (3-851)$$

and Equations 3-778 and 3-779, we obtain

$$V_x = \cos\theta \dot{\xi} - \sin\theta \dot{\eta} \quad (3-852)$$

$$V_z = \sin\theta \dot{\xi} + \cos\theta \dot{\eta} \quad (3-853)$$

We complete the transformation with the trivial definition

$$\Omega_y = \dot{\theta} \quad (3-854)$$

Equations 3-852, 3-853, and 3-854 are of the same form as Equation 2-81 of Paragraph 2.1.2.3. In the present case we have:

$$\begin{aligned} \alpha_{11} &= \cos\theta, & \alpha_{12} &= -\sin\theta, & \alpha_{13} &= 0 \\ \alpha_{21} &= \sin\theta, & \alpha_{22} &= \cos\theta, & \alpha_{23} &= 0 \\ \alpha_{31} &= 0, & \alpha_{32} &= 0, & \alpha_{33} &= 1 \end{aligned}$$

The coefficients defined by Equation 2-106 of Paragraph 2.1.2.3 are

$$\begin{aligned} \Omega_{11} &= 0, & \Omega_{12} &= \Omega_y, & \Omega_{13} &= 0 \\ \Omega_{21} &= -\Omega_y, & \Omega_{22} &= 0, & \Omega_{23} &= 0 \\ \Omega_{31} &= V_z, & \Omega_{32} &= -V_x, & \Omega_{33} &= 0 \end{aligned}$$

Contrails

The "quasi-Lagrange equations" (Equations 2-107) corresponding to the quasi-coordinates, V_x , V_z , and Ω_y are then given by

$$\frac{d}{dt} \left(\frac{\partial T}{\partial V_x} \right) + \Omega_y \left(\frac{\partial T}{\partial V_z} \right) = F_x \quad (3-855)$$

$$\frac{d}{dt} \left(\frac{\partial T}{\partial V_z} \right) - \Omega_y \left(\frac{\partial T}{\partial V_x} \right) = F_z \quad (3-856)$$

$$V_z \frac{\partial T}{\partial V_x} - V_x \frac{\partial T}{\partial V_z} + \frac{d}{dt} \left(\frac{\partial T}{\partial \Omega_y} \right) = G_y \quad (3-857)$$

where

$$F_x = \cos \theta \mathcal{L} - \sin \theta \mathcal{Z} \quad (3-858)$$

$$F_z = \sin \theta \mathcal{L} + \cos \theta \mathcal{Z} \quad (3-859)$$

$$G_y = \Theta \quad (3-860)$$

From the kinetic energy expressed in Equation 3-832, we obtain

$$M \left(\frac{dV_x}{dt} + \Omega_y V_z \right) = F_x \quad (3-861)$$

$$M \left(\frac{dV_x}{dt} - \Omega_y V_x \right) = F_x \quad (3-862)$$

$$\begin{aligned} & (I + \{p\}'[A]\{p\} + 4\{q_R\}'[G]\{p\}) \frac{d\Omega_y}{dt} \\ & + \frac{d}{dt} (\{p\}'[A]\{p\} + 4\{q_R\}'[G]\{p\}) \Omega_y \\ & + 2 \frac{d}{dt} (\{p\}'[G]\{p\}) = G_y \end{aligned} \quad (3-863)$$

Additional differential equations which govern the trajectory are obtained from Equations 3-852, 3-853, and 3-854.

$$\frac{d\xi}{dt} = \cos\theta V_x + \sin\theta V_z \quad (3-864)$$

$$\frac{d\zeta}{dt} = -\sin\theta V_x + \cos\theta V_z \quad (3-865)$$

$$\frac{d\theta}{dt} = \Omega_y \quad (3-866)$$

These equations determine the range, ξ , altitude, ζ , and attitude, θ . (See Figure 58.)

3.2.7 The Relation between the Total Forces, F_x , F_z , and G_y and the Generalized Forces

When the generalized coordinates p_1, p_2, \dots, p_N do not satisfy the constraints (Equations 3-836, 3-837 and 3-838) explicitly, it is possible to derive a convenient relation between the P_i and the total forces, F_x , F_z and G_y . The relations which we want to derive in this section are

$$F_x = \{q_R\}'_1 \{P\} \quad (3-867)$$

$$F_z = \{q_R\}'_2 \{P\} \quad (3-868)$$

Contrails

$$Q_y = \{q_R\}'_3 \{P\} - \{q_R\}'_3 \{N\} \{t\} \quad (3-869)$$

The derivation proceeds as follows. Consider the virtual work of external forces as given in Paragraph 2.1.2.1, Equation 2-48.

$$\delta W = \int \delta \pi \cdot P dV + \oint \delta \pi \cdot \Sigma \cdot dS \quad (3-870)$$

From Equation 3-782, we have

$$\begin{aligned} \delta \pi = \delta R + \delta \theta \left((\bar{x}-x)k + (z-\bar{z})\bar{i} \right) \\ + \delta \theta \left(p_z \bar{i} - p_x k \right) + \delta p_x \bar{i} + \delta p_z k \end{aligned} \quad (3-871)$$

and

$$\begin{aligned} \delta W = \delta R \cdot \bar{i} \left(\int \bar{i} \cdot P dV + \oint \bar{i} \cdot \Sigma \cdot dS \right) \\ + \delta R \cdot k \left(\int k \cdot P dV + \oint k \cdot \Sigma \cdot dS \right) \\ + \delta \theta \left(\int \left((\bar{x}-x)k + (z-\bar{z})\bar{i} \right) \cdot P dV \right. \\ \quad + \oint \left((\bar{x}-x)k + (z-\bar{z})\bar{i} \right) \cdot \Sigma \cdot dS \\ \quad + \int \left(p_z \bar{i} - p_x k \right) \cdot P dV \\ \quad \left. + \oint \left(p_z \bar{i} - p_x k \right) \cdot \Sigma \cdot dS \right) \\ + \{ \delta p \}' \left(\int \{h_x\} \bar{i} \cdot P dV + \oint \{h_x\} \bar{i} \cdot \Sigma \cdot dS \right. \\ \quad \left. + \int \{h_z\} k \cdot P dV + \oint \{h_z\} k \cdot \Sigma \cdot dS \right) \end{aligned} \quad (3-872)$$

Contrails

By comparing this with

$$\delta W = \delta R \cdot \vec{i} F_x + \delta R \cdot \vec{k} F_z + \delta \Theta G_y + \{\delta p\} \{P\} \quad (3-873)$$

we conclude that

$$F_x = \int \vec{i} \cdot P dV + \oint \vec{i} \cdot \vec{\Sigma} \cdot dS \quad (3-874)$$

$$F_z = \int \vec{k} \cdot P dV + \oint \vec{k} \cdot \vec{\Sigma} \cdot dS \quad (3-875)$$

$$G_y = \int ((\bar{x}-x)\vec{k} + (z-\bar{z})\vec{i}) \cdot P dV + \vec{j} \cdot \left(\int p \times P dV + \oint p \times \vec{\Sigma} \cdot dS \right) + \oint ((\bar{x}-x)\vec{k} + (z-\bar{z})\vec{i}) \cdot \vec{\Sigma} \cdot dS \quad (3-876)$$

$$\{P\} = \int (\{h_x\} \vec{i} \cdot P + \{h_z\} \vec{k} \cdot P) dV + \oint (\{h_x\} \vec{i} \cdot \vec{\Sigma} + \{h_z\} \vec{k} \cdot \vec{\Sigma}) \cdot dS \quad (3-877)$$

Now, consider

$$\begin{aligned} \int \{h_x\} \{h_z\} \{P\} &= \int \{h_x\} \{h_z\} (\vec{i} \cdot P + \vec{k} \cdot P) dV + \oint (\{h_x\} \{h_z\} (\vec{i} \cdot \vec{\Sigma} + \vec{k} \cdot \vec{\Sigma})) \cdot dS \\ &= \int \vec{i} \cdot P dV + \oint \vec{i} \cdot \vec{\Sigma} \cdot dS \\ &= F_x \end{aligned} \quad (3-878)$$

Contrails

where use has been made of Equations 3-808 and 3-809. In a similar manner

$$\{\varphi_R\}'_2 \{P\} = \int k \cdot P \, dV + \oint k \cdot \Sigma \cdot dS = F_z \quad (3-879)$$

by using Equations 3-810 and 3-811.

For the total moment, G_y , we have

$$\begin{aligned} \{\varphi_R\}'_3 \{P\} &= \int \{ \varphi_R \}'_3 \{ h_x \} \dot{v} \cdot P + \{ \varphi_R \}'_3 \{ h_z \} k \cdot P \, dV \\ &+ \oint \{ \varphi_R \}'_3 \{ h_x \} \dot{v} \cdot \Sigma + \{ \varphi_R \}'_3 \{ h_z \} k \cdot \Sigma \, dS \\ &= \int ((z-\bar{z})\dot{v} + (\bar{x}-x)k) \cdot P \\ &\quad + \oint ((z-\bar{z})\dot{v} + (\bar{x}-x)k) \cdot \Sigma \, dS \\ &= G_y - \left(\int p \times P \, dV + \oint p \times \Sigma \cdot dS \right) \cdot j \end{aligned} \quad (3-880)$$

It can be shown for the results in Paragraph 3.1.2.5 that in the case of a one-dimensional body:

$$\begin{aligned} -\int (p_x P_z - p_z P_x) \cdot N \, dV &= j \cdot \int (p_x \dot{v} + p_z k) \times (R_x \dot{v} + p_z k) \, dV \\ &= \{\varphi_R\}'_3 [N] \{p\} \end{aligned} \quad (3-881)$$

There is some indication that this relation holds for more general considerations than that of a one-dimensional body. On intuitive grounds we speculate that in the present, more general case, we have

$$\left(\int p \times P dV + \iint p \times \Sigma \cdot dS \right) \cdot j = - \{ \varphi_R \}'_3 [N] \{ p \} \quad (3-882)$$

where $[N]$ is defined in Equation 3-833 and from Equation 3-880

$$\{ \varphi_R \}'_3 \{ P \} = G_y + \{ \varphi_R \}'_3 [N] \{ p \} \quad (3-883)$$

In summary, we have

$$F_x = \{ \varphi_R \}'_1 \{ P \} \quad (3-884)$$

$$F_z = \{ \varphi_R \}'_2 \{ P \} \quad (3-885)$$

$$G_y = \{ \varphi_R \}'_3 \{ P \} - \{ \varphi_R \}'_3 [N] \{ p \} \quad (3-886)$$

3.2.8 Detailed Description of External Forces

In each of the sections below the generalized forces will be derived from the virtual work of external forces from one of several sources. The separate expressions for the generalized forces will be combined in Paragraph 3.2.9.

3.2.8.1 Aerodynamic Forces

As in Paragraph 3.1.1, we will assume the aerodynamic forces to be sufficiently described by the "quasi-steady" assumption. The virtual work of the aerodynamic forces is then

$$\delta W = - \frac{1}{2} \rho \omega v_\omega^2 \int (C_L k - C_D \hat{v}) \cdot \delta p \, dx \quad (3-887)$$

where C_L and C_D are local drag and lift coefficients per unit of length along the vehicle. The "free stream" direction is arbitrarily taken as parallel to the \hat{v} -axis, so that

$$v_\omega = \left(W - \frac{dR}{dt} \right) \cdot \hat{v} \quad (3-888)$$

where W is the wind vector.

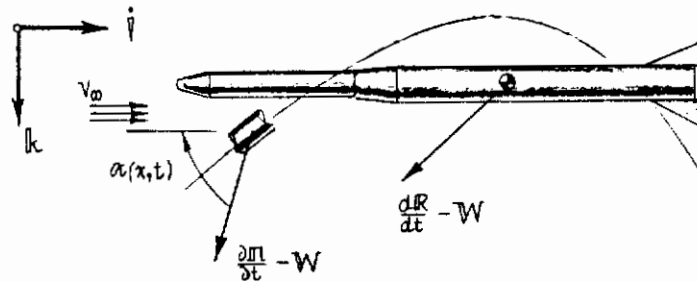

FIGURE 59 AERODYNAMIC ASSUMPTIONS

If μ and κ are unit vectors parallel and normal to the zero angle-of-attack axis at each point along the body, then the local angle-of-attack is

$$\alpha(x,t) = - \frac{\left(\frac{\partial \pi}{\partial t} - W\right) \cdot \kappa}{\left(\frac{\partial \pi}{\partial t} - W\right) \cdot \mu} \quad (3-889)$$

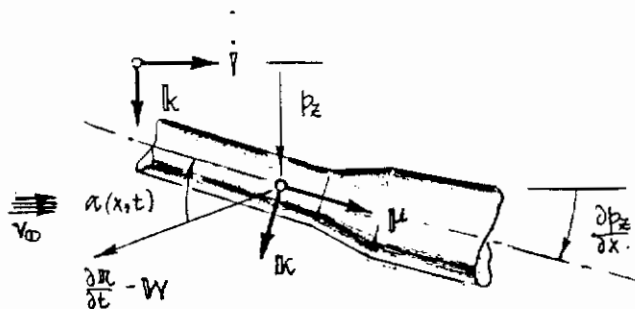

FIGURE 60 LOCAL ANGLE-OF-ATTACK

Contrails

From Figure 60 we can write

$$\mu = \dot{r} + \frac{\partial p_z}{\partial x} k \quad (3-890)$$

$$k = -\frac{\partial p_z}{\partial x} \dot{r} + k \quad (3-891)$$

and also

$$W = W_x \dot{r} + W_z k \quad (3-892)$$

Substituting these into Equation 3-889 and using Equation 3-786, we obtain

$$\alpha(x,t) = -\frac{(V-W) \cdot k}{(V-W) \cdot \dot{r}} + \frac{\partial p_z}{\partial x} + \frac{\frac{\partial p_z}{\partial t} - (x-\bar{x})\dot{\theta}}{(V-W) \cdot \dot{r}} \quad (3-893)$$

where the assumption has been made that the angle-of-attack is small. If we introduce the "rigid-body" angle-of-attack,

$$\alpha = -\frac{(V-W) \cdot k}{(V-W) \cdot \dot{r}} \quad (3-894)$$

then

$$\alpha(x,t) = \alpha + \frac{(x-\bar{x})}{v_\infty} \dot{\theta} + \frac{\partial p_z}{\partial x} + \frac{1}{v_\infty} \frac{\partial p_z}{\partial t} \quad (3-895)$$

The aerodynamic coefficients, C_D and C_L , are assumed to be a function only of the local angle-of-attack. Linearized aerodynamics would predict these to be

$$C_D = \text{a constant, independent of } \alpha(x,t) \quad (3-896)$$

$$C_L = \int L(x,\xi) \alpha(\xi,t) d\xi + C_{L_0}(x) \quad (3-897)$$

Contrails

At high Mach numbers, $M_\infty > 3$, the kernel, $L(x, \xi)$, approaches the form

$$L(x, \xi) = \frac{\partial C_L}{\partial \alpha}(x) \delta(x-\xi) \quad (3-898)$$

where $\delta(x)$ is the Dirac function. Equation 3-897 is then replaced by

$$C_L = \frac{\partial C_L}{\partial \alpha}(x) \alpha(x, t) + C_{L0}(x) \quad (3-899)$$

For the more general case we have

$$\delta W = -\frac{1}{2} \rho_\infty V_\infty^2 \left(\iint \delta p_z(x, t) L(x, \xi) \alpha(\xi, t) d\xi dx \right. \\ \left. - \int \delta p_x C_D dx \right. \\ \left. + \int \delta p_z C_{L0} dx \right) \quad (3-900)$$

Using Equations 3-806, 3-807, 3-811, and 3-813, we can write

$$\delta p_x = \{ \delta p \}' \{ h_x \} \quad (3-901)$$

$$\delta p_z = \{ \delta p \}' \{ h_z \} \quad (3-902)$$

$$\alpha(x, t) = \alpha \{ h_z \}' \{ \varphi_R \}_2 + \frac{\dot{\alpha}}{V_\infty} \{ h_z \}' \{ \varphi_R \}_3 \\ + \{ \frac{dh_z}{dx} \}' \{ p \} + \frac{1}{V_\infty} \{ h_z \}' \{ \dot{p} \} \quad (3-903)$$

Substituting these into Equation 3-900 gives

$$\delta W = -\frac{1}{2} \rho_\infty V_\infty^2 \{ \delta p \}' \left([L_I] \{ \varphi_R \}_2 \alpha + [L_I] \{ \varphi_R \}_3 \frac{\dot{\alpha}}{V_\infty} \right. \\ \left. + [L_R] \{ p \} + \frac{1}{V_\infty} [L_I] \{ \dot{p} \} + \{ C_{L0} \} \right) \quad (3-904)$$

where

Contrails

$$[L_D] = \iint \{h_z(x)\} L(x,s) \left[\frac{dh_z(s)}{ds} \right]' ds dx \quad (3-905)$$

$$[L_I] = \iint \{h_z(x)\} L(x,s) \{h_z(s)\} ds dx \quad (3-906)$$

$$\{L_0\} = \int C_D(x) \{h_x\} dx + \int C_{L_0}(x) \{h_z\} dx. \quad (3-907)$$

and also from Equations 3-888 and 3-894, we have

$$V_w = W_x - V_x \quad (3-908)$$

$$\alpha = - \frac{W_z - V_z}{W_x - V_x} \quad (3-909)$$

The components of wind in the body axis are calculated from

$$W_x = \cos \theta W_\xi - \sin \theta W_\zeta \quad (3-910)$$

$$W_z = \sin \theta W_\xi + \cos \theta W_\zeta \quad (3-911)$$

where W_ξ is the down-range component of wind parallel to the earth's surface and W_ζ is the "up-draft" component normal to the earth's surface

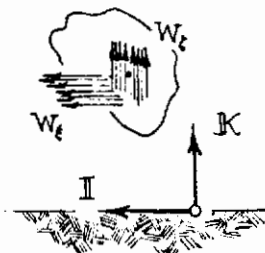

FIGURE 61 WINDS RESOLVED IN THE INERTIAL REFERENCE SYSTEM

The winds, W_{ξ} and W_{ζ} , and the density, ρ_{∞} , are assumed to be known functions of altitude, ζ . The sound speed, c_{∞} , is also a function of ζ and is needed for the calculation of Mach number,

$$M_{\infty} = \frac{V_{\infty}}{c_{\infty}} \quad (3-912)$$

3.2.8.2 Gravity Forces

The gravity field will be assumed to vary with altitude but be uniformly parallel to the inertial axis, \mathcal{K} .

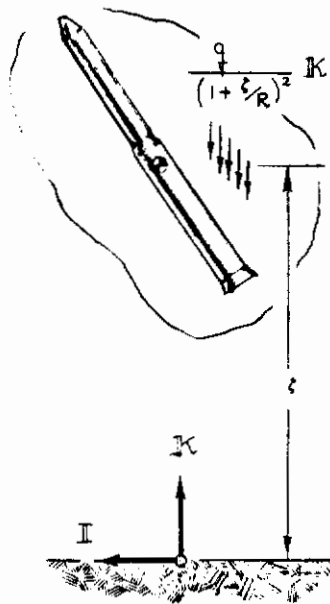

FIGURE 62 APPROXIMATIONS TO INVERSE SQUARE GRAVITY FIELD

Contrails

The force per unit of mass would be

$$\frac{GM}{(r+R)^2}$$

where G is the universal gravitational constant, M is the mass of the gravitating body, and R is the radial distance from the center of the earth to the origin of the (ξ, ζ) coordinates.

If we introduce the local acceleration of gravity, g , at the origin of the (ξ, ζ) coordinates, then

$$g = \frac{GM}{R^2} \tag{3-913}$$

and we can write the gravity vector as

$$-\frac{g}{(1 + \frac{r}{R})^2} \mathbb{K}$$

If we assume this acts uniformly over the entire vehicle, we are neglecting the "gravity gradient torque." The virtual work of the gravity force is then

$$\begin{aligned} \delta W &= - \int \frac{g}{(1 + \frac{r}{R})^2} \rho \mathbb{K} \cdot \delta \mathbf{p} dV \\ &= - \frac{g}{(1 + \frac{r}{R})^2} \left(\int \delta p_x \rho dV \mathbb{K} \cdot \hat{i} + \int \delta p_z \rho dV \mathbb{K} \cdot \hat{k} \right) \end{aligned} \tag{3-914}$$

Using Equations 3-806, 3-807, 3-808 and 3-811, we have

$$\int \delta p_x \rho dV = \{ \delta p \}' [A \quad \mathbb{H} \varphi_R]_1 \tag{3-915}$$

$$\int \delta p_z \rho dV = \{ \delta p \}' [A \quad \mathbb{H} \varphi_R]_2 \tag{3-916}$$

Also, from Equations 3-778 and 3-779

$$K \cdot i = -\sin \theta \quad (3-917)$$

and

$$K \cdot k = \cos \theta \quad (3-918)$$

We then have

$$\delta W = -\frac{q}{(1+J_R)^2} \{ \delta p \} [A] \left(\{ \psi_R \}_2 \cos \theta - \{ \psi_R \}_1 \sin \theta \right) \quad (3-919)$$

3.2.8.3 Thrust Forces

To allow for complete generality, we assume that the distributed thrust on each particle of the system is given by a function of x, y, z , and t as well as the generalized coordinates, p_1, p_2, \dots, p_N . It is generally not a function explicitly of ξ, ζ , or θ .

$$\tau = \tau(x, y, z, t; p_1, p_2, \dots, p_N) \quad (3-920)$$

The dependency on the generalized coordinates is included to allow for the fact that the local thrust vector is redistributed when the body is distorted. In addition, for a gimballed engine, the thrust depends on the generalized coordinates describing the engine swiveling.

The total thrust force is

$$T = \int \tau \, dV \quad (3-921)$$

and the virtual work of the thrust forces is

$$\delta W = \int \tau \cdot \delta p \, dV \quad (3-922)$$

On the basis of the "smallness" of the generalized coordinates, we may write:

$$\tau = \sum_{i=1}^N \frac{\partial \tau}{\partial p_i}(x, y, z, t; 0, 0, \dots, 0) p_i + \tau(x, y, z, t; 0, 0, \dots, 0) \quad (3-923)$$

Contrails

Since

$$\delta p = \{\delta p\}' (\{h_x\}\dot{v} + \{h_z\}k) \quad (3-924)$$

we can write

$$\begin{aligned} \delta w &= \{\delta p\}' \int (\{h_x\} \{ \frac{\partial \tau_x}{\partial p_i} \}' + \{h_z\} \{ \frac{\partial \tau_z}{\partial p_i} \}') dV \{p\} \\ &\quad + \int (\{h_x\} \tau_x + \{h_z\} \tau_z) dV \\ &= -\{\delta p\}' ([H]\{p\} + \{H_0\}) \end{aligned} \quad (3-925)$$

where

$$[H] = \int (\{h_x\} \{ \frac{\partial \tau_x}{\partial p_i} \}' + \{h_z\} \{ \frac{\partial \tau_z}{\partial p_i} \}') dV \quad (3-926)$$

$$\{H_0\} = \int (\{h_x\} \tau_x + \{h_z\} \tau_z) dV \quad (3-927)$$

The above matrices are generally functions of time and the ambient pressure, p_∞ . If the ambient density and speed of sound are assumed to be a function of altitude only, then

$$p_\infty = \frac{\rho_\infty c_\infty^2}{\gamma} \quad (3-928)$$

where γ is the adiabatic constant and

$$\rho_{\infty} = \rho_{\infty}(r) \quad (3-929)$$

$$c_{\infty} = c_{\infty}(r) \quad (3-930)$$

3.2.8.4 Control System Forces

We will assume that there is only one control coordinate, γ , which may be the rotation of a shaft supporting a jet vane, or the gimbal angle of a swiveling engine, or in a generalized case it might be the displacement of a valve controlling the flow rate in a fuel injection mechanism for thrust vectoring. It might also be the rotation at the hinge-line of an aerodynamic surface.

In any case, the control coordinate can be related to the generalized coordinates describing the configuration of the system:

$$\gamma = \{ \eta_{\gamma} \} \{ p \} \quad (3-931)$$

For the case of the fuel injection system, the mechanical generalized coordinates, p_i , must include the description of the valve position; and the variation of thrust with valve position must be included in Equation 3-925.

The control force from the servo is defined by the virtual work of the servo in a virtual displacement of the control coordinate, γ .

$$\delta W = \delta \gamma \Gamma \quad (3-932)$$

The statement describing how Γ depends on the outputs of sensors in the control system is called the "control law" and this is discussed in Paragraph 3.1.3.4.1

If Equation 3-931 is substituted into Equation 3-932, we obtain

$$\delta W = \{ \delta p \}' \{ \eta_{\gamma} \} \Gamma \quad (3-933)$$

¹ A clear statement of this definition of control law, in a sufficiently general form for use in flexible body analysis, appears to have first been given in The Dynamic Response of Advanced Vehicles, WADD TR 60-518, by Q. R. Bohne, et. al. Sept. 1960, Appendix C, Section 2g, p. 176.

so that $\{\eta_y\} \Gamma$ are the generalized forces contributed by the control servo.

3.2.9 Summary of Equations of Motion

From the virtual work expressions of the previous section, the total generalized forces from aerodynamics, thrust, gravity and control are given by

$$\delta W = \{\delta p\} \{P\} \quad (3-934)$$

where

$$\begin{aligned} \{P\} = & -\frac{1}{2} \rho R V_\infty^2 ([L_R] \dot{p}) + \frac{1}{V_\infty} [L_I] \ddot{p} + \{L_0\} \\ & - [A] \left(\frac{q \cos \theta}{(1 + \epsilon_R)^2} \{\psi_R\}_2 - \frac{q \sin \theta}{(1 + \epsilon_R)^2} \{\psi_R\}_3 \right) \\ & - ([H] \dot{p} + \{H_0\}) + \{\eta_y\} \Gamma \\ & - \frac{1}{2} \rho V_\infty^2 [L_I] \left(\{\psi_R\}_2 a + \{\psi_R\}_3 \frac{r_2 y}{V_\infty} \right) \end{aligned} \quad (3-935)$$

If we note that

$$[\Gamma][A] \ddot{p} = [A] \ddot{p} \quad (3-936)$$

which follows from

$$[\varphi_R][A] \dot{p} = \{0\} \quad (3-937)$$

then we can rewrite Equation 3-843 as

Contrails

$$\begin{aligned}
 & [A] \ddot{\beta} + [B] \dot{\beta} + [K] \beta \\
 & = [I] \left(\dot{P} - 2\dot{\omega}_y [G] \dot{\beta} - 4\omega_y [G] \dot{\beta} \right. \\
 & \quad \left. + \omega_y^2 [A] \beta - 2\omega_y^2 [G] \varphi_{R3} - [N] \beta \right)
 \end{aligned} \tag{3-938}$$

These equations must be integrated simultaneously with (see Equations 3-861, 3-862, 3-863, 3-884, 3-885, and 3-886).

$$\frac{dV_x}{dt} = -\omega_y V_z + \frac{1}{M} \{\varphi_{R1}\} \dot{P} \tag{3-939}$$

$$\frac{dV_z}{dt} = \omega_y V_x + \frac{1}{M} \{\varphi_{R2}\} \dot{P} \tag{3-940}$$

$$\frac{dH_y}{dt} = \{\varphi_{R3}\} \dot{P} - \{\varphi_{R3}\} [N] \beta \tag{3-941}$$

where H_y is the y-component of the total angular momentum,

$$\begin{aligned}
 H_y = & \left(I + \beta \dot{\beta} [A] \beta + \beta \dot{\beta} [G] \varphi_{R3} \right) \omega_y \\
 & + 2 \dot{\beta} [G] \beta
 \end{aligned} \tag{3-942}$$

In addition, we have the differential equations

$$\frac{d\xi}{dt} = \cos \theta V_x + \sin \theta V_z \tag{3-943}$$

$$\frac{dr}{dt} = -\sin\theta V_x + \cos\theta V_z \quad (3-944)$$

$$\frac{d\theta}{dt} = \dot{\theta}_y \quad (3-945)$$

3.2.10 Control System Equations

Let ϵ be a signal to the servo to command a control displacement γ . This signal is assumed to depend on the sensors' estimate of the vehicle's attitude, acceleration, and/or angle-of-attack. It also depends on the configuration of the vehicle that is programmed by the guidance system. The particular equation relating ϵ to the vehicle motion can vary widely in form depending on the choice of type and number of sensors and how the sensed signals are mixed and filtered to achieve a stable system. A fairly representative expression for an attitude control system is a simple rate-plus-displacement feedback:

$$\epsilon = K_D(\theta_D - \vartheta) + K_R\dot{\theta}_R \quad (3-946)$$

where ϑ is a prescribed function of time for the vehicle attitude, θ_D is the sensed attitude at the environment of a displacement gyro, and θ_R is the sensed attitude at the environment of a rate gyro. The gains, K_D and K_R , are constants. For "perfect" gyros:

$$\theta_D = \theta - \left(\frac{\partial \theta}{\partial x}\right)_{x=x_D} \quad (3-947)$$

$$\dot{\theta}_R = \dot{\theta} - \left(\frac{\partial^2 \theta}{\partial x \partial t}\right)_{x=x_R} \quad (3-948)$$

where x_D and x_R are x coordinates of the displacement and rate sensors, respectively. Using Equations 3-947 and 3-948, we have

$$\begin{aligned} \epsilon = & K_D(\theta - \vartheta) + K_R\dot{\theta} \\ & - K_D \{h_z(x_D)\}' \{p\} \\ & - K_R \{h_z(x_R)\}' \{p\} \end{aligned} \quad (3-949)$$

Contrails

In this report, an attempt will be made to generalize the above expression to angle-of-attack feedback or other schemes of stabilization, but it must be stressed that any particular scheme may be easily expressed and, in any case, involves only one equation for the variable, ϵ . This equation may be an integro-differential equation when the dynamical characteristics of the sensors are included.

As in Paragraph 3.1.3.4, we may express the moment developed by the servo as

$$\bar{\Gamma}(s) = I(s) (G(s)\bar{\epsilon}(s) - \bar{\mathcal{F}}(s)) \quad (3-950)$$

where the bars denote Laplace transforms and $I(s)$ is the "power control impedance" and $G(s)$ is the "no-load servo impedance." One of the simplest forms of the above equation is

$$\Gamma = J\omega_p^2 (\epsilon - \mathcal{F}) \quad (3-951)$$

where $J\omega_p^2$ is the "zero-frequency back-off stiffness" of the servo actuator (see Paragraph 3.1.3.4, Equation 3-462).

If we let h_1 be one of a number of rigid-body parameters, then we might, for example, have

$$\begin{aligned} h_1 &= \theta - \vartheta \\ h_2 &= \dot{\theta} \\ h_3 &= a \\ h_4 &= \frac{dV_F}{d\epsilon} - \Omega_4 V_x \end{aligned} \quad (3-952)$$

and Equation 3-949 can be generalized to

$$\bar{\epsilon} = \{K(s)\} \{\bar{h}\} + \{L(s)\} \{\bar{\mathcal{F}}\} \quad (3-953)$$

where, again, the bars denote Laplace transforms.

The general form of the control law is then given by

$$\bar{\Gamma} = I(s) (G(s)\bar{\epsilon} - \bar{\mathcal{F}}) \quad (3-954)$$

where

$$\bar{e} = \{K(s)\}' \{ \bar{h} \} + \{L(s)\}' \{ \bar{p} \} \quad (3-955)$$

$I(s)$, $G(s)$, $K_i(s)$, $L_i(s)$ are generally rational functions of s .

3.2.11 The Transformation to Modal Coordinates

In order to reduce the number of degrees-of-freedom (and thus the number of differential equations to be integrated), it is expedient to make a transformation to modal generalized coordinates. It will prove convenient in this transformation for the control coord., γ , to appear explicitly. The vibration modes for locked control are governed by the following equations

$$[\Gamma]'[E][\Gamma][A] \{ \varphi \} = \lambda \{ \varphi \} \quad (3-956)$$

where $[E]$ is the influence matrix for the vehicle with locked controls. We can use the solutions of this equation together with the control mode to form a complete transformation to generalized modal coordinates

$$\{ b \} = [\varphi] \{ q \} + \{ \varphi_\gamma \} \gamma \quad (3-957)$$

where

$$[\varphi] = [\{ \varphi_1 \}, \{ \varphi_2 \}, \dots, \{ \varphi_m \}] \quad (3-958)$$

and $\{ \varphi_\gamma \}$ is assumed to be orthogonal to the other rigid body modes so that

$$\{ \varphi_\gamma \}' [\Gamma] = \{ 0 \}' \quad (3-959)$$

In transforming to modal coordinates, we will make one modification which will greatly simplify the equations from a machine computations standpoint. For this purpose, we will redefine $\{ P \}$, the generalized forces, so that they include the axial load contribution and the nonlinear part of the inertia forces. Thus,

Contrails

$$\begin{aligned}
 \{P\} = & -\frac{1}{2} \rho v_{\infty}^2 ([L_R] \dot{\beta}) + \frac{1}{v_{\infty}} [L_T] \dot{\beta} + \{L_0\} + [L_T] \dot{\phi}_0 \kappa + [L_T] \dot{\phi}_0 \frac{2\dot{\gamma}}{v_{\infty}} \\
 & - \frac{q}{(1+\delta \kappa)^2} [A] (\cos \theta \dot{\phi}_0 - \sin \theta \dot{\phi}_0) + \{\eta_p\} \Gamma \\
 & - ([H] \dot{\beta} + \{H_0\}) - [N] \dot{\beta} - 2\dot{\gamma} [G] \dot{\beta} - 4 [G] \dot{\beta} \\
 & + 4\dot{\gamma}^2 [A] \dot{\beta} - 2\dot{\gamma} [G] \dot{\phi}_0
 \end{aligned} \tag{3-960}$$

If Equation 3-957 is substituted into Equation 3-938 and that equation is premultiplied by $[\phi]'$, we obtain

$$\begin{aligned}
 [\phi]' [A] [\phi] \ddot{\phi}_0 + [\phi]' [A] \dot{\phi}_0 \ddot{\beta} \\
 + [\phi]' [B] [\phi] \dot{\phi}_0 \\
 + [\phi]' [K] [\phi] \dot{\phi}_0 \\
 = [\phi]' [\Gamma] \{P\}
 \end{aligned} \tag{3-961}$$

If Equation 3-938 is premultiplied by $\{\phi_p\}'$, we obtain

$$\{\phi_p\}' [A] [\phi] \ddot{\phi}_0 + \{\phi_p\}' [A] \dot{\phi}_0 \ddot{\beta} = \{\phi_p\}' [\Gamma] \{P\} \tag{3-962}$$

We note that

$$\{\phi_p\}' [\Gamma] = \{\phi_p\}' \tag{3-963}$$

and

$$[\phi]' [\Gamma] = [\phi]' \tag{3-964}$$

Controls

and solve for $\ddot{\gamma}$ in Equation 3-962 and substitute it into Equation 3-961 .
We then obtain

$$[M]\ddot{\gamma} + [R]\dot{\gamma} + [F]\gamma = [Q]^{-1}[Q]HP \quad (3-965)$$

where

$$[M] = [\varphi]'[A][\varphi] - [\varphi]'[A]K\varphi\varphi'K\varphi\varphi'[A]K\varphi\varphi\varphi'^{-1}\varphi\varphi'[A][\varphi] \quad (3-966)$$

$$[R] = [\varphi]'[B][\varphi] \quad (3-967)$$

$$[F] = [\varphi]'[K][\varphi] \quad (3-968)$$

and

$$[Q] = [I] - [A]K\varphi\varphi\varphi'\varphi\varphi'[A]K\varphi\varphi\varphi\varphi'^{-1}\varphi\varphi' \quad (3-969)$$

Also, Equation 3-962 can be written as

$$J\ddot{\gamma} = \varphi\varphi'(iP) - [A][\varphi]K\dot{\gamma} \quad (3-970)$$

where

$$J = \varphi\varphi'[A]K\varphi\varphi' \quad (3-971)$$

One of the advantages of the transformation to modal coordinates is that the approximation of a perfect servo (see Paragraph 3.1.3.4, Equation 3-484) can be handled without restricting the generality of the equations. This is important because the conditions where the perfect servo assumption is valid (Equation 3-481) are equivalent to a high frequency associated with the Lagrange equation for the generalized coordinate, γ , (Equation 3-970). In

Contrails

the numerical integration of the differential equations of motion, the step-size will be dictated by this frequency and will slow down the integration to the extent of making the procedure unfeasible.

When the perfect servo assumption is made, Equation 3-970 is ignored and that equation for determining γ is replaced by

$$\bar{\gamma} = G(s) \bar{e} \quad (3-972)$$

and Γ , the actuator moment, is either calculated as zero from Equation 3-954 or set to zero automatically.

The equation for determining loads (Equation 3-847) can be rewritten as

$$\{L\} = [R][\Gamma] (\{P\} - [A][\varphi][\ddot{q}] - [A][\varphi_p]\ddot{\gamma}) \quad (3-973)$$

where $\{P\}$ is given by Equation 3-960. We may use Equation 3-970 to eliminate $\ddot{\gamma}$ with the result that

$$\{L\} = [R][\Gamma][\Gamma_p] (\{P\} - [A][\varphi][\ddot{q}]) \quad (3-974)$$

where $[\Gamma_p]$ given by Equation 3-969.

Finally, the control system equations in terms of modal coordinates are summarized in the "control law"

$$\bar{\Gamma} = I(s)G(s) (\{K(s)\} \bar{h} + \{L(s)\} [\varphi][\ddot{q}]) - I(s)\bar{\gamma} \quad (3-975)$$

The convolution theorem offers the formal solution to this equation as

$$\begin{aligned} \Gamma &= \int_0^t \{\Gamma_h(t-\tau)\} \{h(\tau)\} d\tau \\ &+ \int_0^t \{\Gamma_q(t-\tau)\} \{q(\tau)\} d\tau \\ &+ \int_0^t \{\Gamma_\gamma(t-\tau)\} \gamma(\tau) d\tau. \end{aligned} \quad (3-976)$$

which can be made the basis for a scheme to include a general control system description in a computer program describing launch vehicle dynamics.

For the simple representation of an attitude control system mentioned earlier, we have

$$\begin{aligned} \Gamma = & J\omega_y^2 K_D(\theta - \vartheta) + J\omega_y^2 K_R \dot{\theta} - J\omega_y^2 \gamma \\ & - J\omega_y^2 K_D \left\{ \frac{dh_z}{dx}(x_D) \right\}' [\varphi] H q \} \\ & - J\omega_y^2 K_R \left\{ \frac{dh_z}{dx}(x_R) \right\}' [\varphi] H \dot{q} \} \end{aligned} \quad (3-977)$$

A summary of the equations derived in this section is given in Figure 63.

3.2.12 The Quasi-Rigid Approximation

The equations derived in this section can be greatly simplified if the quasi-rigid assumption is made (see Paragraph 3.1.2.3). In the present equations this approximation is

$$\{\ddot{q}\} = \{\dot{q}\} = \{0\} \quad (3-978)$$

With this approximation the more significant nonlinear inertia terms are zero. We further neglect the terms

$$\{p\}' [A] H \{p\} + 4\{\varphi_0\}' [G] H \{p\} \quad (3-979)$$

by comparison with I, the undeformed vehicle moment of inertia. We then have

$$H_y = I \Omega_y \quad (3-980)$$

If we recognize that

$$[F] = \left[\frac{1}{\lambda} \right] \quad (3-981)$$

the equations of motion become

$$M \left(\frac{dV_x}{dt} + \dot{\theta} V_z - \frac{g \sin \theta}{(1 + J_R)^2} \right) = \{\varphi_s\}' \{P\} \quad (3-982)$$

$$\begin{aligned}
 M \left(\frac{dV_x}{dt} + \Omega_y V_z \right) &= \{ \varphi_5 \}' \{ P \} \\
 M \left(\frac{dV_z}{dt} - \Omega_y V_x \right) &= \{ \varphi_2 \}' \{ P \} \\
 \frac{dH_y}{dt} &= \{ \varphi_0 \}' \{ P \} \\
 [M] \ddot{\varphi} + [R] \dot{\varphi} + [F] \{ \varphi \} &= \{ \varphi \}' [\Gamma_2] \ddot{P} \\
 J \frac{d^2 \gamma}{dt^2} &= \{ \varphi_2 \}' \{ \dot{P} \} - [A] \{ \varphi \}' H \ddot{\varphi} \\
 \frac{d\xi}{dt} &= \cos \theta V_x + \sin \theta V_z \\
 \frac{d\zeta}{dt} &= -\sin \theta V_x + \cos \theta V_z \\
 \frac{d\theta}{dt} &= \Omega_y \\
 V_{\infty} &= W_x - V_x \\
 \alpha &= -\frac{W_z - V_z}{W_x - V_x} \\
 \Omega_y &= \frac{H_y - 2 \{ \dot{P} \}' [G] H P}{1 + \{ P \}' [A] H P + 4 \{ \varphi_0 \}' [G] H P} \\
 W_x &= \cos \theta W_z - \sin \theta W_y \\
 W_z &= \sin \theta W_z + \cos \theta W_y \\
 \{ \dot{P} \} &= \{ \varphi \}' \{ \dot{Q} \} + \{ \varphi_2 \}' \dot{\gamma} \\
 \{ \ddot{P} \} &= \{ \varphi \}' \{ \ddot{Q} \} + \{ \varphi_2 \}' \ddot{\gamma} \\
 \{ \dot{P} \} &= -\frac{\dot{\gamma}}{(1+\frac{\gamma}{\alpha})^2} [A] \{ \cos \theta \{ \varphi_2 \} - \sin \theta \{ \varphi_3 \} \} - 2 \dot{\alpha} \dot{\gamma} [G] \{ P \} - 4 \Omega_y [G] H \dot{P} \\
 &\quad + \Omega_y^2 [A] H \{ P \} - 2 \Omega_y^2 [G] H \varphi_0 \\
 &\quad - [H] H \{ P \} - \{ H_0 \} - [N] H \{ P \} + \{ \eta_2 \}' \Gamma \\
 -\frac{1}{2} \rho_0 V_{\infty}^2 \left([L_R] H \{ P \} + [L_{-1}] \{ \varphi_2 \}' \alpha + \{ \varphi_0 \}' \frac{d\gamma}{dt} + \frac{1}{V_{\infty}} \{ \dot{P} \}' \right) &= -\frac{1}{2} \rho_0 V_{\infty}^2 \{ L_0 \} \\
 \{ L \} &= [R] \Gamma [L_2] \{ P \} - [A] \{ \varphi \}' H \ddot{\varphi}
 \end{aligned}$$

FIGURE 63 EQUATIONS FOR PLANE MOTION OF A FLEXIBLE LAUNCH VEHICLE

Contrails

$$M \left(\frac{dV_x}{dt} - \dot{\theta} V_x + \frac{g \cos \theta}{(1 + \beta r)^2} \right) = \{ \varphi_r \} \{ P \} \quad (3-983)$$

$$I \frac{d^2 \theta}{dt^2} = \{ \varphi_\theta \} \{ P \} \quad (3-984)$$

$$J \frac{d^2 y}{dt^2} = \{ \varphi_y \} \{ P \} \quad (3-985)$$

$$\{ q \} = \Gamma \lambda \{ \varphi \} \{ \Gamma_p \} \{ P \} \quad (3-986)$$

$$\frac{ds}{dt} = \cos \theta V_x + \sin \theta V_z \quad (3-987)$$

$$\frac{dr}{dt} = -\sin \theta V_x + \cos \theta V_z \quad (3-988)$$

The expressions for the forces reduce to

$$\begin{aligned} \{ P \} = & -\frac{1}{2} \rho_0 V_\infty^2 [L_T] (\{ \varphi_r \} \alpha + \{ \varphi_\theta \} \frac{\dot{\theta}}{V_\infty}) - \frac{1}{2} \rho_0 V_\infty^2 \{ L_O \} \\ & - \{ H_O \} - ([H] + [N] + \frac{1}{2} \rho_0 V_\infty^2 [L_R]) (\{ \varphi \} \{ \Gamma_p \} \{ P \} \\ & + \{ \eta_p \} \Gamma) \end{aligned} \quad (3-989)$$

and the equation for internal loads reduces to

$$\{ L \} = [R] \{ \Gamma \} \{ \Gamma_p \} \{ P \} \quad (3-990)$$

Contrails

The simple attitude control law (Equation 3-971) becomes

$$\Gamma = J\omega_y^2 \left(K_D(\theta - \vartheta) + K_R \dot{\theta} - \gamma \right) - J\omega_y^2 K_D \left\{ \frac{dh_z}{dx^2}(x_D) \right\} \{ \varphi \} \{ q \} \quad (3-991)$$

When $\omega_y \rightarrow \infty$, the perfect servo assumption, becomes valid and Equation 3-985 is replaced by

$$\gamma = K_D(\theta - \vartheta) + K_R \dot{\theta} - K_D \left\{ \frac{dh_z}{dx^2}(x_D) \right\} \{ \varphi \} \{ q \} \quad (3-992)$$

and Γ is set to zero in Equation 3-991.

Contrails

4.0 THE DYNAMICS OF AN UNRESTRAINED ELASTIC STRUCTURE
IN GENERAL SIX-DEGREE-OF-FREEDOM MOTION

Contrails

4.1 THE EQUATIONS OF MOTION OF A SINGLE ELASTIC BODY CONSTITUTING A FIXED SET OF PARTICLES AND EXECUTING LARGE "RIGID BODY" MOTIONS

The object of this section is to derive a practical and general set of equations for an unrestrained elastic body in general motion. The theory presented here is a rational generalization of the work of Euler on the motion of a rigid body and of the work of Lagrange on the small motions of a body having any number of degrees-of-freedom. We have discussed Lagrange's theory in Section 2.2 leading to Equation 2-140.

$$[A] \ddot{\{p\}} + [B] \dot{\{p\}} + [K] \{p\} = \{P\} \quad (4-1)$$

Euler's theory leads to the following equations

$$\begin{aligned} M \left(\frac{dV_x}{dt} - \Omega_z V_y + \Omega_y V_z \right) &= F_x \\ M \left(\frac{dV_y}{dt} + \Omega_z V_x - \Omega_x V_z \right) &= F_y \\ M \left(\frac{dV_z}{dt} - \Omega_y V_x + \Omega_x V_y \right) &= F_z \\ I_{xx} \frac{d\Omega_x}{dt} + (I_{zz} - I_{yy}) \Omega_y \Omega_z &= G_x \\ I_{yy} \frac{d\Omega_y}{dt} + (I_{xx} - I_{zz}) \Omega_x \Omega_z &= G_y \\ I_{zz} \frac{d\Omega_z}{dt} + (I_{yy} - I_{xx}) \Omega_y \Omega_x &= G_z \end{aligned} \quad (4-2)$$

where

(V_x, V_y, V_z) are the body-fixed components of the velocity of one center of mass

$(\Omega_x, \Omega_y, \Omega_z)$ are the body-fixed components of the angular velocity of the body

(F_x, F_y, F_z) are the body-fixed components of the total force

(G_x, G_y, G_z) are the body-fixed components of the total moment of forces about the center of mass

Our interests are in the case where neither of these theories is valid but both are obtained as special cases of a more general theory to be developed.

The results of this section will be used in Section 4.2 to develop a general set of equations describing launch vehicle dynamics.

Following the development in Paragraph 2.1.1 of this report, we will consider that each of the continuum of particles of the body is labeled with coordinates (x, y, z) which correspond to the rectangular coordinates of the point occupied by the x - y - z particle at time, $t = 0$. The Lagrangian coordinates of the particles on the boundary of the body satisfy the equation, say,

$$f(x, y, z) = 0$$

(4-3)

Stated differently, $f(x, y, z) = 0$ is the equation of the bounding surface of the body when it is in its position at $t = 0$.

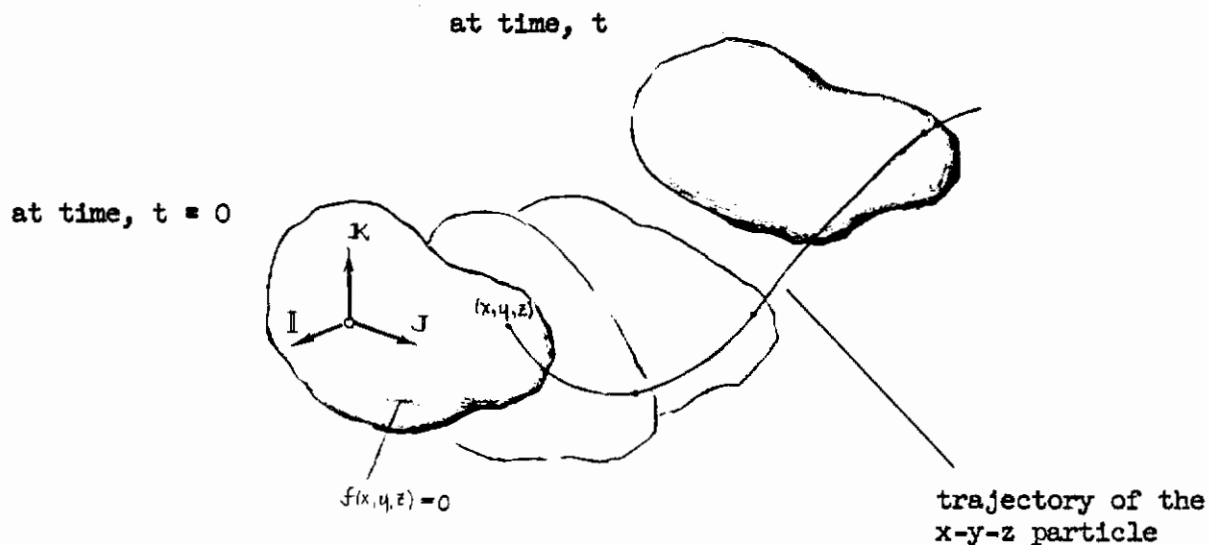

FIGURE 64 MOTION OF AN ELASTIC BODY

In deriving the equations of motion we shall make use of the Principle of Virtual Work (see Equation 2-33 of Paragraph 2.1.1.3).

$$\delta W = \int_{f(x,y,z)=0} \delta \pi \cdot \left(P + \nabla \cdot \sum - \rho \frac{\partial^2 \pi}{\partial t^2} \right) dV = 0 \quad (4-4)$$

Preliminary to this, however, we want to discuss some of the details of the kinematics of the motion.

4.1.1 The Kinematics of an Elastic Body Executing Arbitrarily Large Displacements

It will be convenient to arbitrarily decompose the position vector, $\mathcal{M}(x, y, z, t)$, into a sum of vectors describing the "rigid body" motion and the "elastic" motion. There is no a priori way of assessing how much of the motion of a given particle is due to rigid body motion and how much is due to elastic motion. It should be emphasized that the procedure we shall describe is just one of a number of arbitrary criteria that might be used to separate the motion.

An important property of the gross motion of the body is the path taken by the center-of-mass of the body. The position vector for the center-of-mass is defined by

$$R(t) = \frac{\int \mathcal{M}(x, y, z, t) \rho(x, y, z) dV}{\int \rho(x, y, z) dV} \quad (4-5)$$

(The region of integration, unless otherwise noted, is the whole fixed set of particles inside $f(x, y, z) = 0$.)

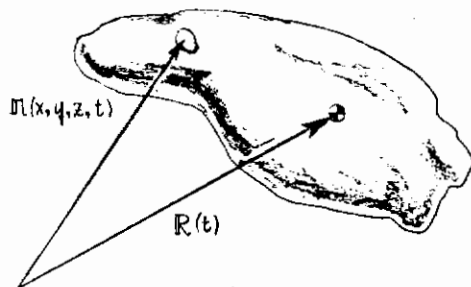

FIGURE 65 CENTER-OF-MASS FOR AN ELASTIC BODY

If we arrange the x-y-z coordinate system so that the origin is at the point which is the center of mass at $t = 0$, then $x = 0, y = 0, z = 0$ labels the particle which, at time $t = 0$, is on top of the center of mass. We then have

Contrails

$$\int x \rho(x, y, z) dV = 0 \quad (4-6)$$

$$\int y \rho(x, y, z) dV = 0 \quad (4-7)$$

$$\int z \rho(x, y, z) dV = 0 \quad (4-8)$$

The inertial reference system $(\mathbb{I}, \mathbb{J}, \mathbb{K})$ is, in some ways, inconvenient for describing the motion of a body. Let us introduce instead a reference system, $(\hat{i}, \hat{j}, \hat{k})$, which is neither fixed in space nor fixed in the body. We will assume it to be arbitrary for the present. The relation between this reference system and the inertial reference system can be specified by a set of Euler angles, ϕ, θ, ψ , (see Figure 67).

We then introduce a position vector that is fixed in this frame of reference and whose length is constantly equal to the distance of the x-y-z particle from the origin $(x = 0, y = 0, z = 0)$ at time, $t = 0$.

$$\mathbb{L}(x, y, z, t) = x\hat{i} + y\hat{j} + z\hat{k} \quad (4-9)$$

The direction of \mathbb{L} depends on the orientation of the "body" axis system, $(\hat{i}, \hat{j}, \hat{k})$. The position vector of a point fixed in the $(\hat{i}, \hat{j}, \hat{k})$ frame of reference is then

$$\mathbb{R}(t) + \mathbb{L}(x, y, z, t)$$

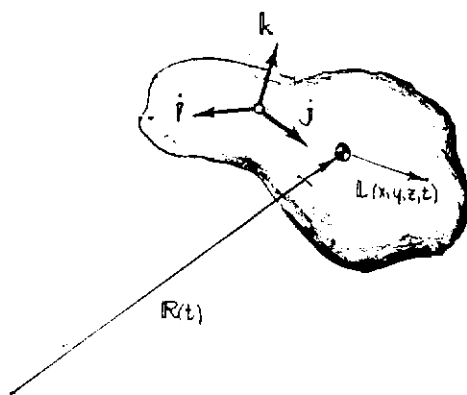

FIGURE 66 A POINT FIXED IN "BODY" AXIS FRAME OF REFERENCE

Contrails

We define the "elastic" displacement vector ("relative" displacement might be a better description) of the x-y-z particle to be

$$p(x, y, z, t) = r(x, y, z, t) - (L(x, y, z, t) + R(t)) \quad (4-10)$$

with the result that the position vector of the x-y-z particle can be written as

$$r(x, y, z, t) = R(t) + L(x, y, z, t) + p(x, y, z, t) \quad (4-11)$$

This definition of elastic displacement leads to the important relation,

$$\int p \rho dV = 0 \quad (4-12)$$

This follows from using Equation 4-10 and the relations defining the center of mass (Equation 4-5).

$$\begin{aligned} \int p \rho dV &= \int r \rho dV - \int L \rho dV - R(t) \int \rho dV \\ &= R(t) \int \rho dV - \int L \rho dV - R(t) \int \rho dV \end{aligned} \quad (4-13)$$

The first and last terms cancel leaving

$$\int L \rho dV$$

which is zero because of Equations 4-6, 4-7, and 4-8.

$$\int L \rho dV = \int (x\hat{i} + y\hat{j} + z\hat{k}) \rho dV = 0 \quad (4-14)$$

The elastic displacement is not completely specified until we say that the $(\hat{i}, \hat{j}, \hat{k})$ frame of reference is. There are a number of possibilities for defining $(\hat{i}, \hat{j}, \hat{k})$ which would tend to make them follow the gross rotational motion of the body. It can be shown that the condition,

$$\int L \times r \rho dV = 0 \quad (4-15)$$

Contrails

Along with the requirement that $|\dot{i}| = |\dot{j}| = |\dot{k}| = 1$ and

$$\dot{i} \times \dot{j} = \dot{k} \quad (4-16)$$

$$\dot{j} \times \dot{k} = \dot{i} \quad (4-17)$$

completely specify the $(\dot{i}, \dot{j}, \dot{k})$ frame of reference as a set of unit, orthogonal, right-handed base vectors.

Equation 4-15 leads immediately to the condition

$$\int L \times \rho \, dV = 0 \quad (4-18)$$

which is true because

$$\int L \times \rho \, dV = \int L \rho \, dV \times R + \int L \times L \rho \, dV = 0 \quad (4-19)$$

from Equation 4-14 and the fact that $L \times L = 0$.

In summary, we have

$$\pi(x, y, z, t) = R(t) + L(x, y, z, t) + p(x, y, z, t) \quad (4-20)$$

where

$$R = \frac{\int \pi \rho \, dV}{\int \rho \, dV} \quad (4-21)$$

and

$$L = x\dot{i} + y\dot{j} + z\dot{k} \quad (4-22)$$

Contrails

and ρ satisfies the following conditions

$$\int \rho \, dV = 0 \quad (4-23)$$

$$\int \mathbf{L} \times \rho \, dV = 0 \quad (4-24)$$

The kinematics of the "rigid-body" reference system is described by the velocity of the center of mass,

$$\mathbf{V}(t) = \frac{d\mathbf{R}}{dt} \quad (4-25)$$

and the angular velocity of the $(\hat{i}, \hat{j}, \hat{k})$ axis system,

$$\boldsymbol{\omega}(t) = \left(\frac{d\hat{j}}{dt} \cdot \hat{k}\right)\hat{i} - \left(\frac{d\hat{i}}{dt} \cdot \hat{k}\right)\hat{j} + \left(\frac{d\hat{i}}{dt} \cdot \hat{j}\right)\hat{k} \quad (4-26)$$

This vector has the property that

$$\frac{\partial \mathbf{L}}{\partial t}(x, y, z, t) = \boldsymbol{\omega} \times \mathbf{L}(x, y, z, t) \quad (4-27)$$

which is characteristic of a vector that is fixed in the $(\hat{i}, \hat{j}, \hat{k})$ frame of reference.

The velocity of the x-y-z particle is given by differentiating Equation 4-20 and using Equation 4-27

$$\begin{aligned} \mathbf{v}(x, y, z, t) &= \frac{\partial \mathbf{r}}{\partial t}(x, y, z, t) \\ &= \frac{d\mathbf{R}}{dt} + \boldsymbol{\omega} \times \mathbf{L} + \frac{\partial \mathbf{p}}{\partial t} \end{aligned} \quad (4-28)$$

Contrails

If we let $p_x(x, y, z, t)$, $p_y(x, y, z, t)$, and $p_z(x, y, z, t)$ denote the components of \mathbf{p} referred to $(\hat{i}, \hat{j}, \hat{k})$, then

$$\mathbf{p} = p_x \hat{i} + p_y \hat{j} + p_z \hat{k} \quad (4-29)$$

and

$$\begin{aligned} \frac{\partial \mathbf{p}}{\partial t}(x, y, z, t) = & \frac{\partial p_x}{\partial t} \hat{i} + \frac{\partial p_y}{\partial t} \hat{j} + \frac{\partial p_z}{\partial t} \hat{k} \\ & + p_x \boldsymbol{\omega} \times \hat{i} + p_y \boldsymbol{\omega} \times \hat{j} + p_z \boldsymbol{\omega} \times \hat{k} \end{aligned} \quad (4-30)$$

If we introduce the notation

$$\dot{\mathbf{p}}(x, y, z, t) = \frac{\partial p_x}{\partial t} \hat{i} + \frac{\partial p_y}{\partial t} \hat{j} + \frac{\partial p_z}{\partial t} \hat{k} \quad (4-31)$$

then

$$\frac{\partial \mathbf{p}}{\partial t} = \dot{\mathbf{p}} + \boldsymbol{\omega} \times \mathbf{p} \quad (4-32)$$

and Equation 4-28 becomes

$$\nabla(x, y, z, t) = \frac{dR}{dt} + \boldsymbol{\omega} \times (\mathbf{L} + \mathbf{p}) + \dot{\mathbf{p}} \quad (4-33)$$

In the Principle of Virtual Work reference is made to the virtual displacement, $\delta \mathbf{r}$, of the x-y-z particle. This can be considered to be due to virtual displacements of the "rigid body" reference system and due to the "elastic" motion relative to this reference system.

$$\delta \mathbf{r} = \delta \mathbf{R} + \delta(x \hat{i} + y \hat{j} + z \hat{k}) + \delta(p_x \hat{i} + p_y \hat{j} + p_z \hat{k}) \quad (4-34)$$

It can be shown¹ that there exists a vector, $\delta\Theta$, such that

$$\begin{aligned}\delta\mathbf{r} &= \delta\Theta \times \mathbf{v} \\ \delta\mathbf{j} &= \delta\Theta \times \mathbf{j} \\ \delta\mathbf{k} &= \delta\Theta \times \mathbf{k}\end{aligned}\tag{4-35}$$

We then have

$$\delta\pi = \delta R + \delta\Theta \times \mathbf{L} + \delta\Theta \times \mathbf{p} + \delta\mathbf{p}\tag{4-36}$$

where we have let

$$\delta\mathbf{p} = \delta p_x \mathbf{i} + \delta p_y \mathbf{j} + \delta p_z \mathbf{k}\tag{4-37}$$

In the Principle of Virtual Work the virtual displacements must satisfy all the kinematical constraints of the system. In particular the virtual displacements must satisfy Equations 4-23 and 4-24.

$$\int \delta p_x dV = 0\tag{4-38}$$

$$\int \mathbf{L} \times \delta p_x dV = 0\tag{4-39}$$

4.1.2 Derivation of the Equations of Motion from the Principle of Virtual Work

From Equation 4-4 we have

$$\delta W = \int \delta \mathbf{m} \cdot \left(\mathbf{P} + \nabla \cdot \Sigma - \rho \frac{\delta^2 \pi}{\delta \mathbf{r}^2} \right) dV = 0\tag{4-40}$$

¹ See Synge and Griffith, Principles of Mechanics, McGraw-Hill, Third Edition, 1959, p. 253.

Contrails

Substituting from Equation 4-36 into Equation 4-40, we obtain

$$\delta W = \int (\delta R + \delta \Theta \times (L + p) + \delta p) \cdot (P + v \cdot \Sigma - e \frac{j_m}{j t^i}) dV = 0 \quad (4-41)$$

subject to the following constraints on δR , $\delta \Theta$, and δp .

$$\int \delta p_e dV = 0 \quad (4-42)$$

and

$$\int L_x \delta p_e dV = 0 \quad (4-43)$$

Following Lagrange's method of undetermined multipliers, we let λ_1 , and λ_2 be, as yet, undetermined vectors and add

$$\lambda_1 \cdot \int \delta p_e dV + \lambda_2 \cdot \int L_x \delta p_e dV$$

to the virtual work. Since this term is zero, we still have $\delta W = 0$.

$$\delta W = \int \left((\delta R + \delta \Theta \times (L + p) + \delta p) \cdot (P + v \cdot \Sigma - e \frac{j_m}{j t^i}) + \lambda_1 \cdot \delta p_e + \lambda_2 \cdot L_x \delta p_e \right) dV = 0 \quad (4-44)$$

This can be also written as

$$\begin{aligned} \delta W = & \int (P + v \cdot \Sigma - e \frac{j_m}{j t^i}) dV \cdot \delta R \\ & \int (L + p) \times (P + v \cdot \Sigma - e \frac{j_m}{j t^i}) dV \cdot \delta \Theta \\ & + \int \delta p \cdot (P + v \cdot \Sigma - e \frac{j_m}{j t^i} + e \lambda_1 + e \lambda_2 \times L) dV = 0 \end{aligned} \quad (4-45)$$

Contrails

By the usual arguments concerning the independency of the virtual displacements, we obtain

$$\int (P + \nabla \cdot \Sigma - \rho \frac{\partial^2 \pi}{\partial t^2}) dV = 0 \quad (4-46)$$

$$\int (L + P) \times (P + \nabla \cdot \Sigma - \rho \frac{\partial^2 \pi}{\partial t^2}) dV = 0 \quad (4-47)$$

$$\int \epsilon P \cdot (P + \nabla \cdot \Sigma - \rho \frac{\partial^2 \pi}{\partial t^2} + \rho \lambda_1 + \rho \lambda_2 \times L) dV = 0 \quad (4-48)$$

From these relations we may derive all the equations governing the motion of the system.

Since we are considering a fixed set of particles, we can write Equation 4-46 as

$$\frac{d^2}{dt^2} \int \rho \pi dV = \int (P + \nabla \cdot \Sigma) dV \quad (4-49)$$

The total external force on the particles is

$$F = \int P dV + \oint \Sigma \cdot dS \quad (4-50)$$

Using the divergence theorem we have, from Equation 4-49,

$$\frac{d^2}{dt^2} \int \rho \pi dV = F \quad (4-51)$$

Contrails

From the definition of the center of mass (Equation 4-5), we can then write Equation 4-51 as

$$\int \rho dV \frac{d^2 \mathbf{R}}{dt^2} = \mathbf{F} \quad (4-52)$$

If we let

$$M = \int \rho dV \quad (4-53)$$

denote the total mass of the body, then

$$M \frac{d^2 \mathbf{R}}{dt^2} = \mathbf{F} \quad (4-54)$$

Equation 4-47 is treated in a similar manner. We first note that

$$\mathbf{L} + \mathbf{p} = \mathbf{n} - \mathbf{R} \quad (4-55)$$

Then Equation 4-47 can be written as

$$\int (\mathbf{n} - \mathbf{R}) \times \rho \frac{\partial^2 \mathbf{n}}{\partial t^2} dV = \int (\mathbf{n} - \mathbf{R}) \times (\mathbf{P} + \nabla \cdot \Sigma) dV \quad (4-56)$$

We can reduce the left-hand side by using the identity

$$\frac{d}{dt} \int (\mathbf{n} - \mathbf{R}) \times \frac{\partial}{\partial t} (\mathbf{n} - \mathbf{R}) \rho dV \equiv \int (\mathbf{n} - \mathbf{R}) \times \rho \frac{\partial^2 \mathbf{n}}{\partial t^2} dV \quad (4-57)$$

and introducing the total angular momentum of the body calculated about the mass center,

$$H = \int (\pi - R) \times \frac{\partial}{\partial t} (\pi - R) \rho dV, \quad (4-58)$$

We obtain

$$\frac{dH}{dt} = \int (\pi - R) \times (P + \nabla \cdot \Sigma) dV. \quad (4-59)$$

We also have

$$\begin{aligned} & \int (\pi - R) \times (P + \nabla \cdot \Sigma) dV \\ &= \int \pi \times (P + \nabla \cdot \Sigma) dV - R \times F \\ &= \int \pi \times P dV + \int \pi \times \nabla \cdot \Sigma dV - R \times F \\ &= \int \pi \times P dV + \int \nabla \cdot (\pi \times \Sigma) dV - R \times F \end{aligned} \quad (4-60)$$

where we have used

$$\int \pi \times \nabla \cdot \Sigma dV = \int \nabla \cdot (\pi \times \Sigma) dV. \quad (4-61)$$

which is true because the integral can be expressed in coordinates for which

$$\pi \times \nabla \cdot \Sigma = \nabla \cdot (\pi \times \Sigma) \quad (4-62)$$

(It can be shown that this is true when the integral is transformed to Eulerian coordinates.)

Contrails

We then have

$$\frac{dH}{dt} = \int \pi \times P dV + \int \nabla \cdot (\pi \times \Sigma) dV - R \times F \quad (4-63)$$

Using the divergence theorem on the second term, we obtain

$$\begin{aligned} \frac{dH}{dt} &= \int \pi \times P dV + \oint \pi \times \Sigma \cdot dS - R \times F \\ &= \int (\pi - R) \times P dV + \oint (\pi - R) \cdot \Sigma \cdot dS \end{aligned} \quad (4-64)$$

The right-hand side can now be recognized as the total moment of external forces calculated about the mass center.

$$G = \int (\pi - R) \times P dV + \oint (\pi - R) \cdot \Sigma \cdot dS \quad (4-65)$$

We then have

$$\frac{dH}{dt} = G \quad (4-66)$$

Turning our attention to Equation 4-48, we assume that ρ can be specified by N generalized coordinates, $p_i(t)$, $i = 1, 2, \dots, N$. Further, we assume that on the basis of ρ being "small" (see also Paragraph 2.3.1), we can write

$$\rho(x, y, z, t) = \sum_{i=1}^N h_i(x, y, z) p_i(t) \quad (4-67)$$

Then

$$\pi(x, y, z, t) = R(t) + L(t) + \sum_{i=1}^N h_i(x, y, z) p_i(t) \quad (4-68)$$

Contrails

We are thus approximating the continuous elastic body by one with $N+6$ degrees-of-freedom. The six generalized coordinates describing the "rigid body" motion could be taken as $\xi, \eta, \zeta, \phi, \theta, \psi$, where ξ, η , and ζ are the inertial coordinates of the center of mass,

$$R(t) = \xi(t)I + \eta(t)J + \zeta(t)K \quad (4-69)$$

and ϕ, θ , and ψ are Euler angles for the $(\hat{i}, \hat{j}, \hat{k})$ frame of reference.

We then have

$$\delta p = \sum_{i=1}^N h_i \delta p_i \quad (4-70)$$

but from Equation 4-68, we also have

$$\frac{\partial \pi}{\partial p_i} = h_i \quad (4-71)$$

so that

$$\delta p = \sum_{i=1}^N \frac{\partial \pi}{\partial p_i} \delta p_i \quad (4-72)$$

Introducing this into Equation 4-48, we have

$$\sum_{i=1}^N \delta p_i \int \frac{\partial \pi}{\partial p_i} \cdot \left(P + \nabla \cdot \Sigma - \rho \frac{\partial^2 \pi}{\partial t^2} + \rho \lambda_1 + \rho \lambda_2 \times \Omega \right) dV = 0 \quad (4-73)$$

The δp_i can be independently varied and λ_1 , and λ_2 can be chosen so that

$$\int \frac{\partial \pi}{\partial p_i} \cdot \left(P + \nabla \cdot \Sigma - \rho \frac{\partial^2 \pi}{\partial t^2} + \rho \lambda_1 + \rho \lambda_2 \times \Omega \right) dV = 0 \quad (4-74)$$

$$i = 1, 2, \dots, N$$

Contrails

Using the identity expressed in Equation 2-43 of Paragraph 2.1.2.1, we have

$$\int \rho \frac{\partial \mathcal{M}}{\partial t} \cdot \frac{\partial \mathcal{M}}{\partial p_i} dV = \frac{d}{dt} \frac{\mathcal{T}}{\partial p_i} - \frac{\mathcal{T}}{\partial p_i} \quad (4-75)$$

where

$$\mathcal{T} = \frac{1}{2} \int \rho \frac{\partial \mathcal{M}}{\partial t} \cdot \frac{\partial \mathcal{M}}{\partial t} dV \quad (4-76)$$

Also, from Equation 2-55 of Paragraph 2.1.2.1, we have

$$\int \frac{\partial \mathcal{M}}{\partial p_i} \cdot (\mathbf{P} + \nabla \cdot \Sigma) dV = P_i - \frac{\partial \mathcal{U}}{\partial p_i} - \frac{\partial \mathcal{R}}{\partial p_i} \quad (4-77)$$

where

$$P_i = \int \frac{\partial \mathcal{M}}{\partial p_i} \cdot \mathbf{P} dV + \oint \frac{\partial \mathcal{M}}{\partial p_i} \cdot \Sigma \cdot dS \quad (4-78)$$

= generalized forces derived from the virtual work of only the external forces.

We then can write Equation 4-74 as

$$\frac{d}{dt} \frac{\mathcal{T}}{\partial p_i} - \frac{\mathcal{T}}{\partial p_i} + \frac{\partial \mathcal{U}}{\partial p_i} + \frac{\partial \mathcal{R}}{\partial p_i} = P_i + \int h_i \cdot (\lambda_1 + \lambda_2 \times \mathbf{L}) \rho dV \quad (4-79)$$

Contrails

The complete equations of motion are then

$$M \frac{d^2 R}{dt^2} = F \quad (4-80)$$

$$\frac{dH}{dt} = G \quad (4-81)$$

$$\frac{d}{dt} \frac{\partial T}{\partial p_i} - \frac{\partial T}{\partial p_i} + \frac{\partial U}{\partial p_i} + \frac{\partial R}{\partial p_i} = P_i + \int h_i (\lambda_1 + \lambda_2 \times L) dV \quad (4-82)$$

$$i = 1, 2, \dots, N$$

4.1.3 The Kinetic Energy of the Body

From Equation 4-76 the kinetic energy is

$$T = \frac{1}{2} \int \rho \frac{\partial \mathbf{m}}{\partial t} \cdot \frac{\partial \mathbf{m}}{\partial t} dV \quad (4-83)$$

and from Equation 4-33, we have

$$\frac{\partial \mathbf{m}}{\partial t} = \frac{dR}{dt} + \Omega \times (L + p) + \dot{p} \quad (4-84)$$

and

$$\begin{aligned} \frac{\partial \mathbf{m}}{\partial t} \cdot \frac{\partial \mathbf{m}}{\partial t} = & \left(\frac{dR}{dt} \right)^2 + 2 \frac{dR}{dt} \cdot \Omega \times (L + p) + 2 \frac{dR}{dt} \cdot \dot{p} \\ & + 2 \Omega \times (L + p) \cdot \dot{p} + (\Omega \times (L + p))^2 + \dot{p}^2 \end{aligned} \quad (4-85)$$

If we introduce the dyadic,

$$(L + p)^2 \mathbb{1} - (L + p)(L + p) \quad (4-86)$$

($\mathbb{1}$ is the Idemdyadic¹)

then we can write

¹Also called Idemfactor and Unit Dyadic; see A. P. Wills Vector Analysis with an Introduction to Tensor Analysis, Dover, 1958, p. 136.

Contrails

$$(\mathbf{L} \times (\mathbf{L} + \mathbf{p}))^2 = \Omega \cdot ((\mathbf{L} + \mathbf{p})^2 \mathbf{1} - (\mathbf{L} + \mathbf{p})(\mathbf{L} + \mathbf{p})) \cdot \Omega \quad (4-87)$$

Substituting this in Equation 4-85 and then into Equation 4-83, we obtain

$$\begin{aligned} \tau = \frac{1}{2} \int & \left(\left(\frac{d\mathbf{R}}{dt} \right)^2 + 2 \frac{d\mathbf{R}}{dt} \cdot \Omega \times (\mathbf{L} + \mathbf{p}) + 2 \frac{d\mathbf{R}}{dt} \cdot \dot{\mathbf{p}} \right. \\ & \left. + 2 \Omega \times (\mathbf{L} + \mathbf{p}) \cdot \dot{\mathbf{p}} + \Omega \cdot ((\mathbf{L} + \mathbf{p})^2 \mathbf{1} - (\mathbf{L} + \mathbf{p})(\mathbf{L} + \mathbf{p})) \cdot \Omega \right) \rho dV \end{aligned} \quad (4-88)$$

Since Ω and \mathbf{R} do not depend on x , y or z , we may take them out of the integral.

$$\begin{aligned} \tau = \frac{1}{2} & \left(\int \rho dV \left(\frac{d\mathbf{R}}{dt} \right)^2 + 2 \frac{d\mathbf{R}}{dt} \cdot \Omega \times \int (\mathbf{L} + \mathbf{p}) \rho dV \right. \\ & + 2 \frac{d\mathbf{R}}{dt} \cdot \int \dot{\mathbf{p}} \rho dV + 2 \Omega \cdot \int (\mathbf{L} + \mathbf{p}) \times \dot{\mathbf{p}} \rho dV \\ & \left. + \Omega \cdot \int ((\mathbf{L} + \mathbf{p})^2 \mathbf{1} - (\mathbf{L} + \mathbf{p})(\mathbf{L} + \mathbf{p})) \rho dV \cdot \Omega \right. \\ & \left. + \int \dot{\mathbf{p}}^2 \rho dV \right) \end{aligned} \quad (4-89)$$

From Equations 4-14 and 4-23, we have

$$\int (\mathbf{L} + \mathbf{p}) \rho dV = 0 \quad (4-90)$$

Also, since (from Equation 4-24)

$$\int \mathbf{L} \times \dot{\mathbf{p}} \rho dV = 0 \quad (4-91)$$

we have, on differentiating,

$$\begin{aligned}
 \frac{d}{dt} \int (\mathbb{L} \times \mathbb{p}) \rho dV &= \int \mathcal{L} \times (\mathbb{L} \times \mathbb{p}) + (\mathbb{L} \times \dot{\mathbb{p}}) \rho dV \\
 &= \mathcal{L} \times \int (\mathbb{L} + \mathbb{p}) \rho dV + \int \mathbb{L} \times \dot{\mathbb{p}} \rho dV \\
 &= \int \mathbb{L} \times \dot{\mathbb{p}} \rho dV
 \end{aligned}
 \tag{4-92}$$

From which we conclude that

$$\int \mathbb{L} \times \dot{\mathbb{p}} \rho dV = 0
 \tag{4-93}$$

In a similar manner

$$\int \dot{\mathbb{p}} \rho dV = 0
 \tag{4-94}$$

Using Equations 4-90, 4-93, and 4-94 we may simplify the kinetic energy

$$\begin{aligned}
 T = \int \left(\frac{1}{2} \rho \frac{d\mathbb{p}^2}{dt} + \mathcal{L} \cdot \int \mathbb{p} \times \dot{\mathbb{p}} \rho dV \right. \\
 \left. + \frac{1}{2} \rho \mathcal{L} \cdot \mathcal{L} + \int \dot{\mathbb{p}}^2 \rho dV \right)
 \end{aligned}
 \tag{4-95}$$

where we have introduced the instantaneous inertia dyadic for the deformed body,

$$\mathbb{A} = \int (\mathbb{L} + \mathbb{p})^2 \mathbb{1} - (\mathbb{L} + \mathbb{p})(\mathbb{L} + \mathbb{p}) \rho dV
 \tag{4-96}$$

and the total mass

$$M = \int \rho dV
 \tag{4-97}$$

Contrails

It will be convenient to express the kinetic energy explicitly in terms of the components of ρ referred to the "body axis" reference system, $(\hat{i}, \hat{j}, \hat{k})$

$$\rho = \rho_x \hat{i} + \rho_y \hat{j} + \rho_z \hat{k} \quad (4-98)$$

We then have

$$\begin{aligned} \int \rho \times \dot{\rho} : dV &= \int (\rho_y \frac{\partial \rho_z}{\partial t} - \rho_z \frac{\partial \rho_y}{\partial t}) : dV \hat{i} \\ &+ \int (\rho_z \frac{\partial \rho_x}{\partial t} - \rho_x \frac{\partial \rho_z}{\partial t}) : dV \hat{j} \\ &+ \int (\rho_x \frac{\partial \rho_y}{\partial t} - \rho_y \frac{\partial \rho_x}{\partial t}) : dV \hat{k} \end{aligned} \quad (4-99)$$

and

$$\int \dot{\rho}^2 : dV = \int (\frac{\partial \rho_x}{\partial t})^2 : dV + \int (\frac{\partial \rho_y}{\partial t})^2 : dV + \int (\frac{\partial \rho_z}{\partial t})^2 : dV \quad (4-100)$$

The inertia dyadic can be expressed as

$$\begin{aligned} \Lambda &= \int ((y + \rho_y)^2 + (z + \rho_z)^2) : dV \hat{i}\hat{i} \\ &- \int (x + \rho_x)(y + \rho_y) : dV (\hat{i}\hat{j} + \hat{j}\hat{i}) \\ &+ \int ((x + \rho_x)^2 + (z + \rho_z)^2) : dV \hat{j}\hat{j} \\ &- \int (x + \rho_x)(z + \rho_z) : dV (\hat{i}\hat{k} + \hat{k}\hat{i}) \\ &+ \int ((x + \rho_x)^2 + (y + \rho_y)^2) : dV \hat{k}\hat{k} \\ &- \int (y + \rho_y)(z + \rho_z) : dV (\hat{j}\hat{k} + \hat{k}\hat{j}) \end{aligned} \quad (4-101)$$

Contrails

This expression can be simplified by making use of the constraint relations, Equations 4-23 and 4-24, written in terms of components. These equations are:

$$\int p_x \rho dV = 0 \quad (4-102)$$

$$\int p_y \rho dV = 0 \quad (4-103)$$

$$\int p_z \rho dV = 0 \quad (4-104)$$

$$\int (y p_z - z p_y) \rho dV = 0 \quad (4-105)$$

$$\int (x p_z - z p_x) \rho dV = 0 \quad (4-106)$$

$$\int (x p_y - y p_x) \rho dV = 0 \quad (4-107)$$

For the sake of brevity we write Equation 4-101 as

$$\begin{aligned} \mathcal{A} = & \lambda_{xx} \hat{i}\hat{i} + \lambda_{xy} \hat{i}\hat{j} + \lambda_{xz} \hat{i}\hat{k} \\ & + \lambda_{yx} \hat{j}\hat{i} + \lambda_{yy} \hat{j}\hat{j} + \lambda_{yz} \hat{j}\hat{k} \\ & + \lambda_{zx} \hat{k}\hat{i} + \lambda_{zy} \hat{k}\hat{j} + \lambda_{zz} \hat{k}\hat{k} \end{aligned} \quad (4-108)$$

Contrails

Then, using Equations 4-102 through 4-107 in Equation 4-101, we have

$$\lambda_{xx} = \int (y^2 + z^2) \rho dV + \int (2y p_y + 2z p_z) \rho dV + \int (p_y^2 + p_z^2) dV \quad (4-109)$$

$$\lambda_{yy} = - \int xy \rho dV - \int (2x p_x + p_x p_x) \rho dV \quad (4-110)$$

$$\lambda_{zz} = - \int xz \rho dV - \int (2z p_x + p_x p_x) \rho dV \quad (4-111)$$

$$\lambda_{yy} = \int (x^2 + z^2) \rho dV + \int (2x p_x + 2z p_z) \rho dV - \int (p_x^2 + p_z^2) dV \quad (4-112)$$

$$\lambda_{yz} = - \int yz \rho dV - \int (2y p_z + p_z p_z) \rho dV \quad (4-113)$$

$$\lambda_{zz} = \int (x^2 + y^2) \rho dV + \int (2x p_x + 2y p_y) \rho dV + \int (p_x^2 + p_y^2) dV \quad (4-114)$$

In these expressions we may recognize the moments and products of inertia of the undeformed body.

$$I_{xx} = \int (y^2 + z^2) \rho dV \quad (4-115)$$

$$I_{yy} = \int (x^2 + z^2) \rho dV \quad (4-116)$$

Contrails

$$I_{xz} = \int xz \rho dV \quad (4-117)$$

$$I_{yy} = \int (x^2 + z^2) \rho dV \quad (4-118)$$

$$I_{yz} = \int yz \rho dV \quad (4-119)$$

$$I_{zz} = \int (x^2 + y^2) \rho dV \quad (4-120)$$

As in Section 3.2, we want to make a finite degree-of-freedom approximation. From Equation 4-67 we have

$$\mathbb{I} = \sum_{i=1}^N h_i(x, y, z) p_i \quad (4-121)$$

Expressed, component wise,

$$h_i(x, y, z) = h_x^{(i)}(x, y, z) \hat{i} + h_y^{(i)}(x, y, z) \hat{j} + h_z^{(i)}(x, y, z) \hat{k} \quad (4-122)$$

and Equation 4-121 can be replaced by

$$p_x = \sum_{i=1}^N h_x^{(i)}(x, y, z) p_i = \{h_x(x, y, z)\}^T \{p_i\} \quad (4-123)$$

$$p_y = \sum_{i=1}^N h_y^{(i)}(x, y, z) p_i = \{h_y(x, y, z)\}^T \{p_i\} \quad (4-124)$$

Contrails

$$F_z = \sum_{i=1}^N h_z^{(i)}(x, y, z) p_i = \{h_z(x, y, z)\} \{p(t)\} \quad (4-125)$$

Using these expressions we can write

$$\int \left(\frac{\partial h_x}{\partial t}\right)' \rho dV = \{p\}' \int \{h_x\} \{h_x\}' \rho dV \{p\} \quad (4-126)$$

$$\int \left(\frac{\partial h_y}{\partial t}\right)' \rho dV = \{p\}' \int \{h_y\} \{h_y\}' \rho dV \{p\} \quad (4-127)$$

$$\int \left(\frac{\partial h_z}{\partial t}\right)' \rho dV = \{p\}' \int \{h_z\} \{h_z\}' \rho dV \{p\} \quad (4-128)$$

$$\int p_x \frac{\partial h_y}{\partial t} \rho dV = \{p\}' \int \{h_x\} \{h_y\}' \rho dV \{p\} \quad (4-129)$$

$$\int p_x \frac{\partial h_z}{\partial t} \rho dV = \{p\}' \int \{h_x\} \{h_z\}' \rho dV \{p\} \quad (4-130)$$

$$\int p_y \frac{\partial h_z}{\partial t} \rho dV = \{p\}' \int \{h_y\} \{h_z\}' \rho dV \{p\} \quad (4-131)$$

We can write these expressions more concisely if we define

$$[A_{xx}] = \int \{h_x\} \{h_x\}' \rho dV \quad (4-132)$$

$$[A_{yy}] = \int \{h_y\} \{h_y\}' \rho dV \quad (4-133)$$

Contrails

$$[A_{zz}] = \int \{h_z\} \{h_z\}' \rho dV \quad (4-134)$$

$$[A_{xy}] = \int \{h_x\} \{h_y\}' \rho dV \quad (4-135)$$

$$[A_{xz}] = \int \{h_x\} \{h_z\}' \rho dV \quad (4-136)$$

$$[A_{yz}] = \int \{h_y\} \{h_z\}' \rho dV \quad (4-137)$$

Equation 4-99 can then be written as

$$\int \rho x \dot{p} \rho dV = \{\dot{p}\}' ([A_{yz}] - [A_{yz}]') \{\dot{p}\} i - \{\dot{p}\}' ([A_{xz}] - [A_{xz}]') \{\dot{p}\} j + \{\dot{p}\}' ([A_{xy}] - [A_{xy}]') \{\dot{p}\} k \quad (4-138)$$

and Equation 4-100 as

$$\int \dot{p}^2 \rho dV = \{\dot{p}\}' ([A_{xx}] + [A_{yy}] + [A_{zz}]) \{\dot{p}\} \quad (4-139)$$

It will be convenient to introduce rigid body modes, $\{\phi_R\}_i$, which represent values of $\{p\}$ corresponding to displacements relative to the (i, j, k) reference system as a rigid body.

A rigid body translation parallel to the x-axis is given by

$$\begin{aligned} p_x &= 1 \\ p_y &= 0 \\ p_z &= 0 \end{aligned} \quad (4-140)$$

Contrails

for each particle. There then exists $\{\phi_R\}_1$ such that

$$1 = \{h_x\}'\{\phi_R\}_1 \quad (4-141)$$

$$0 = \{h_y\}'\{\phi_R\}_1$$

$$0 = \{h_z\}'\{\phi_R\}_1$$

A rigid body rotation about the x-axis, positive according to the right-hand rule, is given by

$$p_x = 0 \quad (4-142)$$

$$p_y = -z$$

$$p_z = y$$

There exists $\{\phi_R\}_4$ such that

$$0 = \{h_x\}'\{\phi_R\}_4 \quad (4-143)$$

$$-z = \{h_y\}'\{\phi_R\}_4$$

$$y = \{h_z\}'\{\phi_R\}_4$$

In general there are six possible independent rigid body modes. If these are taken as

- (1) translation parallel to \hat{V}
- (2) translation parallel to \hat{J}
- (3) translation parallel to \hat{K}
- (4) rotation about \hat{V}
- (5) rotation about \hat{J}
- (6) rotation about \hat{K}

Contrails

Then we have

$$\begin{aligned} \int h_x \delta \varphi_R \delta_1 &= 1 & \int h_x \delta \varphi_R \delta_2 &= 0 & \int h_x \delta \varphi_R \delta_3 &= 0 \\ \int h_y \delta \varphi_R \delta_1 &= 0 & \int h_y \delta \varphi_R \delta_2 &= 1 & \int h_y \delta \varphi_R \delta_3 &= 0 \\ \int h_z \delta \varphi_R \delta_1 &= 0 & \int h_z \delta \varphi_R \delta_2 &= 0 & \int h_z \delta \varphi_R \delta_3 &= 1 \end{aligned} \quad (4-144)$$

$$\begin{aligned} \int h_x \delta \varphi_R \delta_4 &= 0 & \int h_x \delta \varphi_R \delta_5 &= z & \int h_x \delta \varphi_R \delta_6 &= -y \\ \int h_y \delta \varphi_R \delta_4 &= -z & \int h_y \delta \varphi_R \delta_5 &= 0 & \int h_y \delta \varphi_R \delta_6 &= x \\ \int h_z \delta \varphi_R \delta_4 &= y & \int h_z \delta \varphi_R \delta_5 &= -x & \int h_z \delta \varphi_R \delta_6 &= 0 \end{aligned} \quad (4-145)$$

Using these relations, we find that

$$I_{xx} = \int (y^2 + z^2) \rho dV = \int \varphi_R \delta_4' ([A_{xx}] + [A_{yy}] + [A_{zz}]) \delta \varphi_R \delta_4 \quad (4-146)$$

and

$$M = \int \rho dV = \int \varphi_R \delta_1' ([A_{xx}] + [A_{yy}] + [A_{zz}]) \delta \varphi_R \delta_1 \quad (4-147)$$

and, in general

$$\begin{bmatrix} M & 0 & 0 & 0 \\ 0 & M & 0 & 0 \\ 0 & 0 & M & 0 \\ 0 & 0 & 0 & I_{xx} & -I_{xy} & -I_{xz} \\ & & & -I_{xy} & I_{yy} & -I_{yz} \\ & & & -I_{xz} & -I_{yz} & I_{zz} \end{bmatrix} = [\varphi_R]' ([A_{xx}] + [A_{yy}] + [A_{zz}]) [\varphi_R] \quad (4-148)$$

Contrails

Where $[\phi_R]$ is the $N \times 6$ matrix of rigid body modes

$$[\phi_R] = [\{\phi_R\}_1, \{\phi_R\}_2, \dots, \{\phi_R\}_6] \quad (4-149)$$

The components of the inertia dyadic can be written as

$$\lambda_{xx} = I_{xx} + 2(\{\phi_R\}_4' [A_{yz}]' + \{\phi_R\}_5' [A_{xz}]) \{\phi\} + \{\phi\}' ([A_{yy}] + [A_{zz}]) \{\phi\} \quad (4-150)$$

$$\lambda_{xy} = -I_{xy} + 2\{\phi_R\}_5' [A_{yz}]' \{\phi\} - \{\phi\}' [A_{xy}] \{\phi\} \quad (4-151)$$

$$\lambda_{xz} = -I_{xz} + 2\{\phi_R\}_4' [A_{xy}]' \{\phi\} - \{\phi\}' [A_{xz}] \{\phi\} \quad (4-152)$$

$$\lambda_{yy} = I_{yy} + 2(\{\phi_R\}_6' [A_{xy}]' + \{\phi_R\}_5' [A_{xz}]) \{\phi\} + \{\phi\}' ([A_{xx}] + [A_{zz}]) \{\phi\} \quad (4-153)$$

$$\lambda_{yz} = -I_{yz} + 2\{\phi_R\}_6' [A_{xz}]' \{\phi\} - \{\phi\}' [A_{yz}] \{\phi\} \quad (4-154)$$

Contrails

$$\lambda_{zz} = I_{zz} + 2 \left(\dot{\phi}_R \dot{\phi}_\theta' [A_{xy}] + \dot{\phi}_R \dot{\phi}_\theta' [A_{yz}] \right) \dot{\phi} \dot{\theta} + \dot{\phi} \dot{\theta}' ([A_{xx}] + [A_{yy}]) \dot{\phi} \dot{\theta} \quad (4-155)$$

The kinetic energy (Equation 4-95) for the finite degree-of-freedom system is

$$\begin{aligned} T = \frac{1}{2} & \left(M \left(\frac{dR}{dt} \right)^2 + 2 \Omega_x \dot{\phi} \dot{\theta}' ([A_{yz}] - [A_{zy}]) \dot{\phi} \dot{\theta} \right. \\ & - 2 \Omega_y \dot{\phi} \dot{\theta}' ([A_{xz}] - [A_{zx}]) \dot{\phi} \dot{\theta} \\ & \left. + 2 \Omega_z \dot{\phi} \dot{\theta}' ([A_{xy}] - [A_{yx}]) \dot{\phi} \dot{\theta} \right. \\ & + \lambda_{xx} \dot{\phi}^2 + 2 \lambda_{xy} \dot{\phi} \dot{\theta} + \lambda_{xz} \dot{\phi} \dot{\theta} \\ & + \lambda_{yy} \dot{\theta}^2 + 2 \lambda_{yz} \dot{\theta} \dot{\phi} \\ & \left. + \lambda_{zz} \dot{\phi} \dot{\theta} + \dot{\phi} \dot{\theta}' ([A_{xx}] + [A_{yy}] + [A_{zz}]) \dot{\phi} \dot{\theta} \right) \end{aligned} \quad (4-156)$$

where Ω_x , Ω_y , and Ω_z are the components of the angular velocity vector referred to $(\hat{i}, \hat{j}, \hat{k})$.

$$\Omega = \Omega_x \hat{i} + \Omega_y \hat{j} + \Omega_z \hat{k} \quad (4-157)$$

4.1.4 The Strain Energy of the Body

The specific internal strain energy of a particle of a continuous elastic body can be written in a very general form as¹

$$\begin{aligned}
 u(x, y, z, t) = & \frac{1}{2} \left(\frac{E}{1+\nu} \frac{2(1-\nu)}{(1-2\nu)} (\epsilon_{xx}^2 + \epsilon_{yy}^2 + \epsilon_{zz}^2) \right. \\
 & + \frac{\lambda E}{(1+\nu)(1-2\nu)} (\epsilon_{xx}\epsilon_{yy} + \epsilon_{yy}\epsilon_{zz} + \epsilon_{zz}\epsilon_{xx}) \\
 & \left. + \frac{E}{2(1+\nu)} (\epsilon_{xy}^2 + \epsilon_{yz}^2 + \epsilon_{xz}^2) \right) \quad (4-158)
 \end{aligned}$$

The Lagrangian-coordinate components of strain can be written directly in terms of the displacements relative to the $(\bar{i}, \bar{j}, \bar{k})$ frame of reference²

$$\epsilon_{xx} = \frac{\partial p_x}{\partial \bar{x}} \quad (4-159)$$

$$\epsilon_{yy} = \frac{\partial p_y}{\partial \bar{y}} \quad (4-160)$$

$$\epsilon_{zz} = \frac{\partial p_z}{\partial \bar{z}} \quad (4-161)$$

$$\epsilon_{xy} = \frac{\partial p_x}{\partial \bar{y}} + \frac{\partial p_y}{\partial \bar{x}} \quad (4-162)$$

¹See Timoshenko and Goodier, Theory of Elasticity, McGraw-Hill, 1951, p. 148 equation (85).

²This statement requires proof. It can be shown that the "exact" definition of strain used in conjunction with the assumption of small displacements relative to $(\bar{i}, \bar{j}, \bar{k})$ would give the result stated in Equations 4-159 through 4-164. For the "exact" definition of the Lagrangian strains, reference should be made to Green and Zerna Theoretical Elasticity, Oxford, 1954, section 2.2, p. 57.

Continuity

$$\epsilon_{xz} = \frac{\partial p_x}{\partial z} + \frac{\partial p_z}{\partial x} \quad (4-163)$$

$$\epsilon_{yz} = \frac{\partial p_y}{\partial z} + \frac{\partial p_z}{\partial y} \quad (4-164)$$

Using Equations 4-123, 4-124, and 4-125, these can be written in terms of the generalized coordinates, p_i .

$$\epsilon_{xx} = \left\{ \frac{\partial h_x}{\partial x} \right\}' \{p\} \quad (4-165)$$

$$\epsilon_{yy} = \left\{ \frac{\partial h_y}{\partial y} \right\}' \{p\} \quad (4-166)$$

$$\epsilon_{zz} = \left\{ \frac{\partial h_z}{\partial z} \right\}' \{p\} \quad (4-167)$$

$$\epsilon_{xy} = \left(\left\{ \frac{\partial h_x}{\partial y} \right\}' + \left\{ \frac{\partial h_y}{\partial x} \right\}' \right) \{p\} \quad (4-168)$$

$$\epsilon_{xz} = \left(\left\{ \frac{\partial h_x}{\partial z} \right\}' + \left\{ \frac{\partial h_z}{\partial x} \right\}' \right) \{p\} \quad (4-169)$$

$$\epsilon_{yz} = \left(\left\{ \frac{\partial h_y}{\partial z} \right\}' + \left\{ \frac{\partial h_z}{\partial y} \right\}' \right) \{p\} \quad (4-170)$$

Substituting this into Equation 4-158 and integrating,

$$U = \int u \, dV \quad (4-171)$$

we obtain the following expression for the total strain energy

$$U = \frac{1}{2} \{p\}' [K] \{p\} \quad (4-172)$$

where

$$\begin{aligned}
 [K] = & \int \left(\frac{Ez(1-\nu)}{(1+\nu)(1-2\nu)} \left(\left\{ \frac{\partial h_x}{\partial x} \right\} \left\{ \frac{\partial h_x}{\partial x} \right\}' + \left\{ \frac{\partial h_y}{\partial y} \right\} \left\{ \frac{\partial h_y}{\partial y} \right\}' \right. \right. \\
 & + \left. \left\{ \frac{\partial h_z}{\partial z} \right\} \left\{ \frac{\partial h_z}{\partial z} \right\}' \right) + \frac{2E}{(1+\nu)(1-2\nu)} \left(\left\{ \frac{\partial h_x}{\partial x} \right\} \left\{ \frac{\partial h_y}{\partial y} \right\}' \right. \\
 & + \left. \left\{ \frac{\partial h_y}{\partial y} \right\} \left\{ \frac{\partial h_x}{\partial x} \right\}' + \left\{ \frac{\partial h_y}{\partial y} \right\} \left\{ \frac{\partial h_z}{\partial z} \right\}' + \left\{ \frac{\partial h_z}{\partial z} \right\} \left\{ \frac{\partial h_y}{\partial y} \right\}' \right. \\
 & + \left. \left. \left\{ \frac{\partial h_z}{\partial z} \right\} \left\{ \frac{\partial h_x}{\partial x} \right\}' + \left\{ \frac{\partial h_x}{\partial x} \right\} \left\{ \frac{\partial h_z}{\partial z} \right\}' \right) + \frac{E}{2(1+\nu)} \left(\left\{ \frac{\partial h_x}{\partial y} \right\} \left\{ \frac{\partial h_y}{\partial x} \right\}' \right. \\
 & + \left. \left\{ \frac{\partial h_y}{\partial x} \right\} \left\{ \frac{\partial h_x}{\partial y} \right\}' + \left\{ \frac{\partial h_y}{\partial x} \right\} \left\{ \frac{\partial h_y}{\partial x} \right\}' + \left\{ \frac{\partial h_z}{\partial z} \right\} \left\{ \frac{\partial h_x}{\partial x} \right\}' + \left\{ \frac{\partial h_x}{\partial x} \right\} \left\{ \frac{\partial h_z}{\partial z} \right\}' \right. \\
 & + \left. \left. \left\{ \frac{\partial h_y}{\partial z} \right\} \left\{ \frac{\partial h_z}{\partial y} \right\}' + \left\{ \frac{\partial h_z}{\partial y} \right\} \left\{ \frac{\partial h_y}{\partial z} \right\}' + \left\{ \frac{\partial h_x}{\partial x} \right\} \left\{ \frac{\partial h_x}{\partial y} \right\}' + \left\{ \frac{\partial h_x}{\partial y} \right\} \left\{ \frac{\partial h_x}{\partial x} \right\}' \right. \\
 & + \left. \left. \left. \left\{ \frac{\partial h_x}{\partial z} \right\} \left\{ \frac{\partial h_z}{\partial x} \right\}' + \left\{ \frac{\partial h_z}{\partial x} \right\} \left\{ \frac{\partial h_x}{\partial z} \right\}' + \left\{ \frac{\partial h_y}{\partial z} \right\} \left\{ \frac{\partial h_z}{\partial y} \right\}' \right. \right. \\
 & \left. \left. \left. + \left\{ \frac{\partial h_z}{\partial y} \right\} \left\{ \frac{\partial h_y}{\partial z} \right\}' \right) \right) dV
 \end{aligned} \tag{4-173}$$

In practical structural analyses Equation 4-173 would never be used directly but the general approach would be the same except the strain-displacement relations would be replaced by approximate ones appropriate to beams, plates, shells, etc.

4.1.5 The Dissipation Function for the Body

In a similar manner we may derive an expression for Rayleigh's dissipation function. The general form of Hooke's law for a static stress state is

$$\sigma_{xx} = \lambda(\epsilon_{xx} + \epsilon_{yy} + \epsilon_{zz}) + 2G \epsilon_{xx} \tag{4-174}$$

$$\sigma_{yy} = \lambda(\epsilon_{xx} + \epsilon_{yy} + \epsilon_{zz}) + 2G \epsilon_{yy} \tag{4-175}$$

Contrails

$$\sigma_{zz} = \lambda (\epsilon_{xx} + \epsilon_{yy} + \epsilon_{zz}) + 2G \epsilon_{zz} \quad (4-176)$$

$$\sigma_{xy} = G \epsilon_{xy} \quad (4-177)$$

$$\sigma_{xz} = G \epsilon_{xz} \quad (4-178)$$

$$\sigma_{yz} = G \epsilon_{yz} \quad (4-179)$$

where λ is Lamé's constant

$$\lambda = \frac{\gamma E}{(1+\gamma)(1-2\gamma)} \quad (4-180)$$

and G is the shear modulus

$$G = \frac{E}{2(1+\gamma)} \quad (4-181)$$

Following Volterra¹ we may generalize these relations, in the dynamic case, to

$$\bar{\sigma}_{xx} = (\lambda + s\bar{\mu}) (\bar{\epsilon}_{xx} + \bar{\epsilon}_{yy} + \bar{\epsilon}_{zz}) + 2(G + sR) \bar{\epsilon}_{xx} \quad (4-182)$$

$$\bar{\sigma}_{yy} = (\lambda + s\bar{\mu}) (\bar{\epsilon}_{xx} + \bar{\epsilon}_{yy} + \bar{\epsilon}_{zz}) + 2(G + sR) \bar{\epsilon}_{yy} \quad (4-183)$$

$$\bar{\sigma}_{zz} = (\lambda + s\bar{\mu}) (\bar{\epsilon}_{xx} + \bar{\epsilon}_{yy} + \bar{\epsilon}_{zz}) + 2(G + sR) \bar{\epsilon}_{zz} \quad (4-184)$$

$$\bar{\sigma}_{xy} = (G + sR) \bar{\epsilon}_{xy} \quad (4-185)$$

$$\bar{\sigma}_{xz} = (G + sR) \bar{\epsilon}_{xz} \quad (4-186)$$

$$\bar{\sigma}_{yz} = (G + sR) \bar{\epsilon}_{yz} \quad (4-187)$$

where the bar denotes the Laplace transform with respect to time,

$$\bar{\sigma}_{xx}(x, y, z, s) = \int_0^{\infty} \sigma_{xx}(x, y, z, t) e^{-st} dt \quad (4-188)$$

¹ Enrico Volterra, On Elastic Continua with Hereditary Characteristics, Journal of Applied Mechanics, September, 1951, equation (14).

Contraills

Volterra has shown that invariancy under a rotation of axes indicates that only two parameters are pertinent to the description of the strain rate terms. The functions

$$\mu(x, y, z, t) \quad (4-189)$$

and $R(x, y, z, t) \quad (4-190)$

are called hereditary functions. We suppose that in the frequency range of interest in structural vibrations we can say that

$$\bar{\mu}(x, y, z, s) = \mu(x, y, z) \quad \text{independent of } s \quad (4-191)$$

$$\bar{R}(x, y, z, s) = R(x, y, z) \quad \text{independent of } s \quad (4-192)$$

(This classifies the internal energy dissipation as what is generally called viscous damping.)

The generalized stress-strain relations are then given by

$$\sigma_{xx} = \lambda(\epsilon_{xx} + \epsilon_{yy} + \epsilon_{zz}) + \mu(\dot{\epsilon}_{xx} + \dot{\epsilon}_{yy} + \dot{\epsilon}_{zz}) + 2G\epsilon_{xx} + 2R\dot{\epsilon}_{xx} \quad (4-193)$$

$$\sigma_{yy} = \lambda(\epsilon_{xx} + \epsilon_{yy} + \epsilon_{zz}) + \mu(\dot{\epsilon}_{xx} + \dot{\epsilon}_{yy} + \dot{\epsilon}_{zz}) + 2G\epsilon_{yy} + 2R\dot{\epsilon}_{yy} \quad (4-194)$$

$$\sigma_{zz} = \lambda(\epsilon_{xx} + \epsilon_{yy} + \epsilon_{zz}) + \mu(\dot{\epsilon}_{xx} + \dot{\epsilon}_{yy} + \dot{\epsilon}_{zz}) - 2G\epsilon_{zz} + 2R\dot{\epsilon}_{zz} \quad (4-195)$$

$$\sigma_{xy} = G\epsilon_{xy} + R\dot{\epsilon}_{xy} \quad (4-196)$$

$$\sigma_{yz} = G\epsilon_{yz} + R\dot{\epsilon}_{yz} \quad (4-197)$$

$$\sigma_{xz} = G\epsilon_{xz} + R\dot{\epsilon}_{xz} \quad (4-198)$$

The virtual work of the internal forces is given by

Contrails

$$\delta W = - \int \left(\sigma_{xx} \delta \epsilon_{xx} + \sigma_{yy} \delta \epsilon_{yy} + \sigma_{zz} \delta \epsilon_{zz} + \sigma_{xy} \delta \epsilon_{xy} + \sigma_{xz} \delta \epsilon_{xz} + \sigma_{yz} \delta \epsilon_{yz} \right) dV \quad (4-199)$$

Substituting the stresses in Equations 4-193 through 4-198, we obtain

$$\begin{aligned} \delta W = & - \int \left(\lambda (\dot{\epsilon}_{xx} + \dot{\epsilon}_{yy} + \dot{\epsilon}_{zz}) \delta \epsilon_{xx} + 2G \dot{\epsilon}_{xx} \delta \epsilon_{xx} \right. \\ & + \lambda (\dot{\epsilon}_{xx} + \dot{\epsilon}_{yy} + \dot{\epsilon}_{zz}) \delta \epsilon_{yy} + 2G \dot{\epsilon}_{yy} \delta \epsilon_{yy} \\ & + \lambda (\dot{\epsilon}_{xx} + \dot{\epsilon}_{yy} + \dot{\epsilon}_{zz}) \delta \epsilon_{zz} + 2G \dot{\epsilon}_{zz} \delta \epsilon_{zz} \\ & \left. + G \dot{\epsilon}_{xy} \delta \epsilon_{xy} + G \dot{\epsilon}_{xz} \delta \epsilon_{xz} + G \dot{\epsilon}_{yz} \delta \epsilon_{yz} \right) dV \\ & - \int \left(\mu (\dot{\epsilon}_{xx} + \dot{\epsilon}_{yy} + \dot{\epsilon}_{zz}) \delta \epsilon_{xx} + 2R \dot{\epsilon}_{xx} \delta \epsilon_{xx} \right. \\ & - \mu (\dot{\epsilon}_{xx} + \dot{\epsilon}_{yy} + \dot{\epsilon}_{zz}) \delta \epsilon_{yy} + 2R \dot{\epsilon}_{yy} \delta \epsilon_{yy} \\ & + \mu (\dot{\epsilon}_{xx} + \dot{\epsilon}_{yy} + \dot{\epsilon}_{zz}) \delta \epsilon_{zz} + 2R \dot{\epsilon}_{zz} \delta \epsilon_{zz} \\ & \left. + R \dot{\epsilon}_{xy} \delta \epsilon_{xy} + R \dot{\epsilon}_{xz} \delta \epsilon_{xz} + R \dot{\epsilon}_{yz} \delta \epsilon_{yz} \right) dV \end{aligned} \quad (4-200)$$

The first integral is $-\delta U$ and has already been accounted for in deriving Equation 4-173. Making use of Equations 4-123, 4-124, and 4-125, Equation 4-200 becomes

$$\delta W = -\delta U - \{ \delta p \} \{ \delta H \} \quad (4-201)$$

Contrails

where

$$\begin{aligned}
 [B] = & \int \left[(\mu + 2R) \left\{ \frac{\partial h_x}{\partial x} \frac{\partial h_x}{\partial x} + \frac{\partial h_y}{\partial y} \frac{\partial h_y}{\partial y} + \frac{\partial h_z}{\partial z} \frac{\partial h_z}{\partial z} \right\}' \right. \\
 & + \mu \left\{ \frac{\partial h_x}{\partial x} \frac{\partial h_y}{\partial y} + \frac{\partial h_y}{\partial y} \frac{\partial h_x}{\partial x} + \frac{\partial h_y}{\partial y} \frac{\partial h_z}{\partial z} \right. \\
 & \quad \left. \left. + \frac{\partial h_z}{\partial z} \frac{\partial h_y}{\partial y} + \frac{\partial h_z}{\partial z} \frac{\partial h_x}{\partial x} + \frac{\partial h_x}{\partial x} \frac{\partial h_z}{\partial z} \right\}' \right) \\
 & + R \left\{ \frac{\partial h_x}{\partial y} \frac{\partial h_x}{\partial y} + \frac{\partial h_y}{\partial x} \frac{\partial h_y}{\partial x} + \frac{\partial h_x}{\partial z} \frac{\partial h_x}{\partial z} \right. \\
 & \quad \left. + \frac{\partial h_z}{\partial x} \frac{\partial h_z}{\partial x} + \frac{\partial h_y}{\partial z} \frac{\partial h_y}{\partial z} + \frac{\partial h_z}{\partial y} \frac{\partial h_z}{\partial y} \right. \\
 & \quad \left. + \frac{\partial h_y}{\partial x} \frac{\partial h_x}{\partial y} + \frac{\partial h_x}{\partial y} \frac{\partial h_y}{\partial x} + \frac{\partial h_x}{\partial z} \frac{\partial h_z}{\partial x} \right. \\
 & \quad \left. + \frac{\partial h_z}{\partial x} \frac{\partial h_x}{\partial z} + \frac{\partial h_y}{\partial z} \frac{\partial h_z}{\partial y} + \frac{\partial h_z}{\partial y} \frac{\partial h_y}{\partial z} \right\}' \Big] dV
 \end{aligned}$$

(4-202)

In the very special case that $\mu = \beta \lambda$ and $R = \beta G$, we have, by comparing Equation 4-173 with Equation 4-202,

$$[B] = \beta [K] \tag{4-203}$$

and the comments concerning Equation 2-292 of Paragraph 2.2.3.5 apply.

From Equation 4-201 and the symmetry of $[B]$, it can be shown that a dissipation function exists such that

$$R = \frac{1}{2} \{ \dot{\beta} \}' [B] \{ \dot{\beta} \} \tag{4-204}$$

4.1.6 The Complete Set of Differential Equations Governing the Motion of the Body

The total angular momentum of the system (Equation 4-58) is

$$H = \int (\mathbf{r}-\mathbf{R}) \times \frac{d}{dt}(\mathbf{r}-\mathbf{R}) \rho dV \quad (4-205)$$

In this expression

$$\mathbf{r}-\mathbf{R} = \mathbf{L} + \mathbf{p} \quad (4-206)$$

and

$$\frac{d}{dt}(\mathbf{r}-\mathbf{R}) = \boldsymbol{\Omega} \times (\mathbf{L} + \mathbf{p}) + \dot{\mathbf{p}} \quad (4-207)$$

so that

$$H = \int (\mathbf{L} + \mathbf{p}) \times (\boldsymbol{\Omega} \times (\mathbf{L} + \mathbf{p})) \rho dV + \int (\mathbf{L} + \mathbf{p}) \times \dot{\mathbf{p}} \rho dV \quad (4-208)$$

The first term can be written as $\mathbf{A} \cdot \boldsymbol{\Omega}$ where \mathbf{A} is given by Equation 4-96. In the second term we can use Equation 4-93 so that

$$H = \mathbf{A} \cdot \boldsymbol{\Omega} + \int \mathbf{p} \times \dot{\mathbf{p}} \rho dV \quad (4-209)$$

which may be expressed in terms of the generalized coordinates, p_i , by using Equations 4-138 and 4-150 through 4-155.

Using the results of the previous section in Equation 4-82, we will have the Lagrange equations corresponding to p_i , $i = 1, 2, \dots, N$. From Equation 4-156, we have

$$\left\{ \frac{\partial T}{\partial p_i} \right\} = \begin{bmatrix} \frac{\partial T}{\partial p_1} \\ \frac{\partial T}{\partial p_2} \\ \vdots \\ \frac{\partial T}{\partial p_N} \end{bmatrix} = \begin{bmatrix} -\Omega_x ([A_{yz}] - [A_{yz}]') \{p\} \\ + \Omega_y ([A_{xz}] - [A_{xz}]') \{p\} \\ - \Omega_z ([A_{xy}] - [A_{xy}]') \{p\} \\ + ([A_{xx}] + [A_{yy}] + [A_{zz}]) \{p\} \end{bmatrix} \quad (4-210)$$

Contrails

and

$$\begin{aligned}
 \left\{ \frac{\partial T}{\partial p_i} \right\} &= \omega_x ([A_{yz}] - [A_{yz}]') \{ \dot{p} \} \\
 &\quad - \omega_y ([A_{xz}] - [A_{xz}]') \{ \dot{p} \} \\
 &\quad + \omega_z ([A_{xy}] - [A_{xy}]') \{ \dot{p} \} \\
 &= \frac{1}{2} \omega_x^2 \left\{ \frac{\partial \lambda_{xy}}{\partial p_i} \right\} + \omega_x \omega_y \left\{ \frac{\partial \lambda_{xy}}{\partial p_i} \right\} + \omega_x \omega_z \left\{ \frac{\partial \lambda_{xz}}{\partial p_i} \right\} \\
 &\quad + \frac{1}{2} \omega_y^2 \left\{ \frac{\partial \lambda_{yz}}{\partial p_i} \right\} + \omega_y \omega_z \left\{ \frac{\partial \lambda_{yz}}{\partial p_i} \right\} \\
 &\quad + \frac{1}{2} \omega_z^2 \left\{ \frac{\partial \lambda_{zx}}{\partial p_i} \right\}
 \end{aligned}
 \tag{4-211}$$

Also, from Equation 4-172

$$\left\{ \frac{\partial U}{\partial p_i} \right\} = [K] \{ \dot{p} \}
 \tag{4-212}$$

and from Equation 4-204

$$\left\{ \frac{\partial R}{\partial p_i} \right\} = [B] \{ \dot{p} \}
 \tag{4-213}$$

If we let

$$\lambda_1 = \lambda_1 \hat{i} + \lambda_2 \hat{j} + \lambda_3 \hat{k}
 \tag{4-214}$$

and

$$\lambda_2 = \lambda_4 \hat{i} + \lambda_5 \hat{j} + \lambda_6 \hat{k}
 \tag{4-215}$$

Contrails

then we can write the generalized constraint forces as

$$\begin{aligned} & \int h_j \cdot (\lambda_1 + \lambda_2 \times L) \rho dV \\ &= \int (h_x^{(i)} \lambda_1 + h_y^{(i)} \lambda_2 + h_z^{(i)} \lambda_3) \rho dV \\ &+ \int \begin{vmatrix} h_x^{(i)} & h_y^{(i)} & h_z^{(i)} \\ \lambda_4 & \lambda_5 & \lambda_6 \\ x & y & z \end{vmatrix} \rho dV \end{aligned} \tag{4-216}$$

Using Equations 4-144, we have

$$\begin{aligned} & \int \{h\} \cdot (\lambda_1 + \lambda_2 \times L) \rho dV \\ &= ([A_{xx}] + [A_{yy}] + [A_{zz}]) \{i\varphi_R\}_1 \lambda_1 + \{i\varphi_R\}_2 \lambda_2 + \{i\varphi_R\}_3 \lambda_3 \\ &+ \{i\varphi_R\}_4 \lambda_4 + \{i\varphi_R\}_5 \lambda_5 + \{i\varphi_R\}_6 \lambda_6 = [A] \{i\varphi_R\}_2 \lambda \end{aligned} \tag{4-217}$$

where

$$[A] = [A_{xx}] + [A_{yy}] + [A_{zz}] \tag{4-218}$$

Before substituting these relations into Equations 4-82, let us express the constraints (Equations 4-102 through 4-107) in terms of the p_1 . Again, using Equations 4-123, 4-124, and 4-125, and, also, 4-144 and 4-145, we have

$$\int p_x \rho dV = \{i\varphi_R\}'_1 [A] \{i\beta\} = 0 \tag{4-219}$$

$$\int p_y \rho dV = \{i\varphi_R\}'_2 [A] \{i\beta\} = 0 \tag{4-220}$$

$$\int p_z \rho dV = \{i\varphi_R\}'_3 [A] \{i\beta\} = 0 \tag{4-221}$$

Contrails

$$\int (y p_z - z p_y) \rho dV = \{\varphi_R\}'_4 [A] \{p\} = 0 \quad (4-222)$$

$$\int (x p_z - z p_x) \rho dV = \{\varphi_R\}'_5 [A] \{p\} = 0 \quad (4-223)$$

$$\int (x p_y - y p_x) \rho dV = \{\varphi_R\}'_6 [A] \{p\} = 0 \quad (4-224)$$

which can be written concisely (from Equation 4-149) as

$$[\varphi_R]' [A] \{p\} = \{0\} \quad (4-225)$$

which bears a remarkable similarity to Equation 2-261 of Paragraph 2.2.3.4.¹

We also have

$$[K] \{\varphi_R\}_i = \{0\} \quad (4-226)$$

and

$$[B] \{\varphi_R\}_i = \{0\} \quad (4-227)$$

which follows because the strains (Equations 4-165 through 4-170) are zero for

$$\{p\} = \{\phi_R\}_i$$

$$\left\{ \frac{\partial h_x}{\partial x} \right\}' \{\varphi_R\}_i = 0 \quad (4-228)$$

$$\left\{ \frac{\partial h_y}{\partial y} \right\}' \{\varphi_R\}_i = 0 \quad (4-229)$$

$$\left\{ \frac{\partial h_z}{\partial z} \right\}' \{\varphi_R\}_i = 0 \quad (4-230)$$

$$\left(\left\{ \frac{\partial h_x}{\partial y} \right\}' + \left\{ \frac{\partial h_y}{\partial x} \right\}' \right) \{\varphi_R\}_i = 0 \quad (4-231)$$

$$\left(\left\{ \frac{\partial h_x}{\partial z} \right\}' + \left\{ \frac{\partial h_z}{\partial x} \right\}' \right) \{\varphi_R\}_i = 0 \quad (4-232)$$

¹This similarity is a consequence of the choice of

$$\int \mathbf{L} \times \mathbf{p} \rho dV = 0$$

as a constraint on \mathbf{p} (see Equation 4-18). This gives a motive, a posteriori, for making this choice.

Contrails

$$\left(\left\{ \frac{\partial h_i}{\partial z} \right\}' + \left\{ \frac{\partial h_i}{\partial y} \right\}' \right) \{ \varphi_R \}_i = 0 \quad (4-233)$$

Using Equation 4-217, Equation 4-232 can be written as

$$\left\{ \frac{d}{dt} + \frac{\partial T}{\partial p_i} \right\} - \left\{ \frac{\partial T}{\partial p_i} \right\} + \left\{ \frac{\partial U}{\partial p_i} \right\} + \left\{ \frac{\partial R}{\partial p_i} \right\} = \{ P \} + [A][\varphi_R] \{ \lambda \} \quad (4-234)$$

Premultiply by $[\varphi_R]'$ and use

$$[\varphi_R]' \left(\left\{ \frac{\partial U}{\partial p_i} \right\} + \left\{ \frac{\partial R}{\partial p_i} \right\} \right) = \{ 0 \} \quad (4-235)$$

which is equivalent to Equations 4-226 and 4-227. Then

$$[\varphi_R]' \left(\left\{ \frac{d}{dt} + \frac{\partial T}{\partial p_i} \right\} - \left\{ \frac{\partial T}{\partial p_i} \right\} - \{ P \} \right) = [\varphi_R]' [A][\varphi_R] \{ \lambda \} \quad (4-236)$$

Solving for the λ 's, we have

$$\{ \lambda \} = \left([\varphi_R]' [A][\varphi_R] \right)^{-1} [\varphi_R]' \left(\left\{ \frac{d}{dt} + \frac{\partial T}{\partial p_i} \right\} - \left\{ \frac{\partial T}{\partial p_i} \right\} - \{ P \} \right) \quad (4-237)$$

Substituting this into Equation 4-234 yields

$$[\Gamma] \left(\left\{ \frac{d}{dt} + \frac{\partial T}{\partial p_i} \right\} - \left\{ \frac{\partial T}{\partial p_i} \right\} - \{ P \} \right) + \left\{ \frac{\partial U}{\partial p_i} \right\} + \left\{ \frac{\partial R}{\partial p_i} \right\} = \{ 0 \} \quad (4-238)$$

where

$$[\Gamma] = [I] - [A][\varphi_R]' \left([\varphi_R]' [A][\varphi_R] \right)^{-1} [\varphi_R] \quad (4-239)$$

Following Hamilton we can reduce the system to a set of first order equations by introducing the generalized momenta as additional coordinates. If the generalized momenta are denoted by h_i , then

$$h_i = \frac{\partial T}{\partial p_i} \quad (4-240)$$

and we can write Equation 4-210 as

$$\begin{aligned} \{ h \} &= -\Omega_x \left([A_{yz}] - [A_{yz}]' \right) \{ p \} \\ &\quad + \Omega_y \left([A_{xz}] - [A_{xz}]' \right) \{ p \} \\ &\quad - \Omega_z \left([A_{xy}] - [A_{xy}]' \right) \{ p \} + [A] \{ \dot{p} \} \\ &= \left(-\Omega_x [G_{yz}] + \Omega_y [G_{xz}] - \Omega_z [G_{xy}] \right) \{ p \} + [A] \{ \dot{p} \} \end{aligned}$$

(4-241)

Contrails

where the $[G]$'s are the anti-symmetrical part of the $[A]$'s

$$[G_{yz}] = \frac{[A_{yz}] - [A_{zy}]}{2} \quad (4-242)$$

$$[G_{xz}] = \frac{[A_{xz}] - [A_{zx}]}{2} \quad (4-243)$$

$$[G_{xy}] = \frac{[A_{xy}] - [A_{yx}]}{2} \quad (4-244)$$

We can also write Equation 4-241 as

$$\begin{aligned} \{\dot{p}\} = [A]^{-1} \{k\} - [A]^{-1} \left(-2\omega_x [G_{yz}] + 2\omega_y [G_{xz}] \right. \\ \left. - 2\omega_z [G_{xy}] \right) \{p\} \end{aligned} \quad (4-245)$$

Using Equations 4-211, 4-212, and 4-213 in Equation 4-238, we have

$$\begin{aligned} [D] \{k\} - [D] \left(-2\omega_x [G_{yz}] - 2\omega_y [G_{xz}] + 2\omega_z [G_{xy}] \right) \{p\} \\ - [D] \left(\frac{\partial^2}{\partial t^2} \left\{ \frac{\partial \lambda_{xy}}{\partial p_i} \right\} + \omega_x \omega_y \left\{ \frac{\partial \lambda_{xz}}{\partial p_i} \right\} - \omega_x \omega_z \left\{ \frac{\partial \lambda_{yz}}{\partial p_i} \right\} \right. \\ \left. + \frac{\partial^2}{\partial t^2} \left\{ \frac{\partial \lambda_{yz}}{\partial p_i} \right\} + \omega_y \omega_z \left\{ \frac{\partial \lambda_{xy}}{\partial p_i} \right\} \right. \\ \left. - \frac{\partial^2}{\partial t^2} \left\{ \frac{\partial \lambda_{zz}}{\partial p_i} \right\} \right) \\ + [K] \{p\} + [B] \{\dot{p}\} = [D] \{P\} \end{aligned} \quad (4-246)$$

Using Equations 4-150, through 4-155, we have

$$\begin{aligned} \frac{\partial \lambda_{xy}}{\partial p_i} = 2 \left([A_{yz}] \{q_k\}_4 + [A_{xz}] \{q_k\}_5 \right) \\ + 2 \left([A_{yy}] + [A_{zz}] \right) \{p\} \end{aligned} \quad (4-247)$$

Contrails

$$\left\{ \frac{\partial \lambda_{xy}}{\partial p_i} \right\} = 2 [A_{yz}] \{ \varphi_R \}_5 - ([A_{xy}] + [A_{xy}]') \{ p \} \quad (4-248)$$

$$\left\{ \frac{\partial \lambda_{xz}}{\partial p_i} \right\} = 2 [A_{xy}] \{ \varphi_R \}_4 - ([A_{xz}] + [A_{xz}]') \{ p \} \quad (4-249)$$

$$\left\{ \frac{\partial \lambda_{yy}}{\partial p_i} \right\} = 2 \left([A_{xy}] \{ \varphi_R \}_6 + [A_{xz}]' \{ \varphi_R \}_5 \right) + 2 ([A_{xx}] + [A_{zz}]) \{ p \} \quad (4-250)$$

$$\left\{ \frac{\partial \lambda_{yz}}{\partial p_i} \right\} = 2 [A_{xz}]' \{ \varphi_R \}_6 - ([A_{yz}] + [A_{yz}]') \{ p \} \quad (4-251)$$

$$\left\{ \frac{\partial \lambda_{zz}}{\partial p_i} \right\} = 2 ([A_{xy}] \{ \varphi_R \}_6 + [A_{yz}] \{ \varphi_R \}_4) + 2 ([A_{xx}] + [A_{yy}]) \{ p \} \quad (4-252)$$

For simplicity we introduce the following symmetric matrices

$$[H_{xx}] = \frac{[A_{xy}] + [A_{zz}]}{2} \quad (4-253)$$

$$[H_{yy}] = \frac{[A_{xx}] + [A_{zz}]}{2} \quad (4-254)$$

$$[H_{zz}] = \frac{[A_{xx}] + [A_{yy}]}{2} \quad (4-255)$$

$$[H_{xy}] = \frac{[A_{xy}] + [A_{xy}]'}{2} \quad (4-256)$$

$$[H_{xz}] = \frac{[A_{xz}] + [A_{xz}]'}{2} \quad (4-257)$$

$$[H_{yz}] = \frac{[A_{yz}] + [A_{yz}]'}{2} \quad (4-258)$$

Contrails

Equation 4-246 then becomes

$$\begin{aligned}
 [\Gamma] \dot{\mathbf{h}} &= [\Gamma] (2\Omega_x [G_{yz}] - 2\Omega_y [G_{xz}] + 2\Omega_z [G_{xy}]) \dot{\mathbf{p}} \\
 &- [\Gamma] \left(\frac{\Omega_x^2}{2} + [H_{xx}] - \Omega_x \Omega_y 2 [H_{xy}] - \Omega_x \Omega_z 2 [H_{yz}] \right. \\
 &\quad \left. + \frac{\Omega_y^2}{2} + 4 [H_{yy}] - 2\Omega_y \Omega_z 2 [H_{yz}] \right. \\
 &\quad \left. + \frac{\Omega_z^2}{2} + [H_{zz}] \right) \dot{\mathbf{p}} \\
 &- [\Gamma] \left(\frac{\Omega_x^2}{2} 2 ([A_{yz}] \dot{\varphi}_R^4 + [A_{xz}] \dot{\varphi}_R^5) \right. \\
 &\quad \left. + 2\Omega_x \Omega_y 2 [A_{yz}] \dot{\varphi}_R^5 + 2\Omega_x \Omega_z 2 [A_{xy}] \dot{\varphi}_R^4 \right. \\
 &\quad \left. + \frac{\Omega_y^2}{2} 2 ([A_{xy}] \dot{\varphi}_R^6 + [A_{xz}] \dot{\varphi}_R^5) \right. \\
 &\quad \left. + 2\Omega_y \Omega_z 2 [A_{xz}] \dot{\varphi}_R^6 \right. \\
 &\quad \left. - \frac{\Omega_x^2}{2} 2 ([A_{xy}] \dot{\varphi}_R^6 + [A_{yz}] \dot{\varphi}_R^4) \right) \\
 &+ [\kappa] \dot{\mathbf{p}} + [\beta] \dot{\mathbf{p}} = \dot{\mathbf{P}}
 \end{aligned}
 \tag{4-259}$$

This equation is to be solved simultaneously with Equation 4-245

$$\dot{\mathbf{p}} = [A]^{-1} \dot{\mathbf{h}} - [A]^{-1} (2\Omega_x [G_{yz}] - 2\Omega_y [G_{xz}] + 2\Omega_z [G_{xy}])
 \tag{4-260}$$

The rigid body equations (Equations 4-80 and 4-81) must also be solved simultaneously with the above equations.

From Equation 4-80, we have

$$M \frac{d\mathbf{V}}{dt} = \mathbf{F}
 \tag{4-261}$$

Contrails

where

$$\mathbf{V} = \frac{d\mathbf{R}}{dt} \quad (4-262)$$

If we denote the components of \mathbf{V} by V_x , V_y , and V_z , then

$$\mathbf{V} = V_x \mathbf{i} + V_y \mathbf{j} + V_z \mathbf{k} \quad (4-263)$$

and

$$\begin{aligned} \frac{d\mathbf{V}}{dt} &= \frac{dV_x}{dt} \mathbf{i} + \frac{dV_y}{dt} \mathbf{j} + \frac{dV_z}{dt} \mathbf{k} \\ &\quad + V_x \boldsymbol{\Omega} \times \mathbf{i} + V_y \boldsymbol{\Omega} \times \mathbf{j} + V_z \boldsymbol{\Omega} \times \mathbf{k} \\ &= \left(\frac{dV_x}{dt} - \Omega_z V_y + \Omega_y V_z \right) \mathbf{i} \\ &\quad + \left(\frac{dV_y}{dt} + \Omega_z V_x - \Omega_x V_z \right) \mathbf{j} \\ &\quad + \left(\frac{dV_z}{dt} - \Omega_y V_x + \Omega_x V_y \right) \mathbf{k} \end{aligned} \quad (4-264)$$

Equation 4-261 is then equivalent to the following three scalar equations

$$\frac{dV_x}{dt} = \Omega_z V_y - \Omega_y V_z + \frac{1}{M} F_x \quad (4-265)$$

$$\frac{dV_y}{dt} = -\Omega_z V_x + \Omega_x V_z + \frac{1}{M} F_y \quad (4-266)$$

$$\frac{dV_z}{dt} = \Omega_y V_x - \Omega_x V_y + \frac{1}{M} F_z \quad (4-267)$$

where

$$\mathbf{F} = F_x \mathbf{i} + F_y \mathbf{j} + F_z \mathbf{k} \quad (4-268)$$

In a similar manner, Equation 4-81 leads to the following scalar equations

$$\frac{dH_x}{dt} = \Omega_z H_y - \Omega_y H_z + G_x \quad (4-269)$$

$$\frac{dH_y}{dt} = -\Omega_z H_x + \Omega_x H_z + G_y \quad (4-270)$$

$$\frac{dH_z}{dt} = \Omega_y H_x - \Omega_x H_y + G_z \quad (4-271)$$

Contrails

where

$$H = H_x \hat{i} + H_y \hat{j} + H_z \hat{k} \quad (4-272)$$

The relation between the total angular momentum, H , and the angular velocity vector, Ω , is obtained from Equation 4-209 using Equation 4-138

$$H_x = \lambda_{xx} \Omega_x + \lambda_{xy} \Omega_y + \lambda_{xz} \Omega_z + 2 \{p\}' [G_{yz}] \{ \dot{p} \} \quad (4-273)$$

$$H_y = \lambda_{xy} \Omega_x + \lambda_{yy} \Omega_y + \lambda_{yz} \Omega_z - 2 \{p\}' [G_{xz}] \{ \dot{p} \} \quad (4-274)$$

$$H_z = \lambda_{xz} \Omega_x + \lambda_{yz} \Omega_y + \lambda_{zz} \Omega_z + 2 \{p\}' [G_{xy}] \{ \dot{p} \} \quad (4-275)$$

where the λ 's are given by Equations 4-150 through 4-155.

Finally, we want to derive a useful relation between the total force and moment and the generalized forces, P_i . From Equations 4-50, 4-65, and 4-78, we have

$$F = \int P \, dV + \iint \Sigma \cdot dS \quad (4-276)$$

$$G = \int (L+p) \times P \, dV + \iint (L+p) \times \Sigma \cdot dS \quad (4-277)$$

$$P_i = \int h_i \cdot P \, dV + \iint h_i \cdot \Sigma \cdot dS \quad (4-278)$$

From Equation 4-278, we have

$$\begin{aligned} & \hat{i} \{ \varphi_{r1} \}' \{ P \} + \hat{j} \{ \varphi_{r2} \}' \{ P \} + \hat{k} \{ \varphi_{r3} \}' \{ P \} \\ &= \int (\hat{i} \{ \varphi_{r1} \}' \{ h \} + \hat{j} \{ \varphi_{r2} \}' \{ h \} + \hat{k} \{ \varphi_{r3} \}' \{ h \}) \cdot P \, dV \\ & \quad + \iint (\hat{i} \{ \varphi_{r1} \}' \{ h \} + \hat{j} \{ \varphi_{r2} \}' \{ h \} + \hat{k} \{ \varphi_{r3} \}' \{ h \}) \cdot \Sigma \cdot dS \\ &= (\hat{i} \hat{i} + \hat{j} \hat{j} + \hat{k} \hat{k}) \cdot \left(\int P \, dV + \iint \Sigma \cdot dS \right) \\ &= \hat{1} \cdot F \\ &= F \end{aligned} \quad (4-279)$$

Contrails

where use has been made of Equations 4-144 and 4-145. From this we conclude, by equating components, that

$$F_x = \{ \varphi_{R1}' \{ P \} \} \quad (4-280)$$

$$F_y = \{ \varphi_{R2}' \{ P \} \} \quad (4-281)$$

$$F_z = \{ \varphi_{R3}' \{ P \} \} \quad (4-282)$$

The moment can be treated in a similar fashion if an approximation is made. From Equation 4-277, we have

$$\begin{aligned} G = & \int L \times P dV + \oint\!\!\!\oint L \times E \cdot dS \\ & + \int p \times P dV + \oint\!\!\!\oint p \times E \cdot dS \end{aligned} \quad (4-283)$$

The contribution of the last two terms to the total moment of forces is negligible if the displacements relative to the $(\hat{i}, \hat{j}, \hat{k})$ reference are small. Approximately, then

$$G = \int L \times P dV + \oint\!\!\!\oint L \times E \cdot dS \quad (4-284)$$

Consider,

$$\begin{aligned} & \hat{i} \{ \varphi_{R4}' \{ P \} \} + \hat{j} \{ \varphi_{R5}' \{ P \} \} + \hat{k} \{ \varphi_{R6}' \{ P \} \} \\ & = \int (\hat{i} \{ \varphi_{R4}' \{ h \} \} + \hat{j} \{ \varphi_{R5}' \{ h \} \} + \hat{k} \{ \varphi_{R6}' \{ h \} \}) \cdot P dV \\ & \quad + \oint\!\!\!\oint (\hat{i} \{ \varphi_{R4}' \{ h \} \} + \hat{j} \{ \varphi_{R5}' \{ h \} \} + \hat{k} \{ \varphi_{R6}' \{ h \} \}) \cdot \Sigma \cdot dS \\ & = \int (L \times \hat{1}) \cdot P dV + \oint\!\!\!\oint (L \times \hat{1}) \cdot \Sigma \cdot dS \\ & = \int L \times P dV + \oint\!\!\!\oint L \times \Sigma \cdot dS \\ & = G \end{aligned} \quad (4-285)$$

Contrails

From this we conclude that

$$G_x = \{\varphi_R\}'_4 \{P\} \quad (4-286)$$

$$G_y = \{\varphi_R\}'_5 \{P\} \quad (4-287)$$

$$G_z = \{\varphi_R\}'_6 \{P\} \quad (4-288)$$

In summary, the complete set of equations governing the motion of the body are

$$\frac{dV_x}{dt} = \Omega_z V_y - \Omega_y V_z + \frac{1}{M} F_x \quad (4-289)$$

$$\frac{dV_y}{dt} = -\Omega_z V_x + \Omega_x V_z + \frac{1}{M} F_y \quad (4-290)$$

$$\frac{dV_z}{dt} = \Omega_y V_x - \Omega_x V_y + \frac{1}{M} F_z \quad (4-291)$$

$$\frac{dH_x}{dt} = \Omega_z H_y - \Omega_y H_z + G_x \quad (4-292)$$

$$\frac{dH_y}{dt} = -\Omega_z H_x + \Omega_x H_z + G_y \quad (4-293)$$

$$\frac{dH_z}{dt} = \Omega_y H_x - \Omega_x H_y + G_z \quad (4-294)$$

and

$$\begin{aligned} [\Gamma]\{\dot{h}\} = & -[\Gamma][G]\{\dot{p}\} + [\Gamma][H]\{\dot{p}\} + [\Gamma][K]\{\dot{p}\} \\ & - [\kappa][\dot{p}] - [B]\{\dot{p}\} + \{P\} \end{aligned} \quad (4-295)$$

$$[A]\{\dot{p}\} = \{h\} - [G]\{\dot{p}\} \quad (4-296)$$

This can also be written as the single second order equation:

$$[A]\{\ddot{p}\} + [B]\{\dot{p}\} + [\kappa][\dot{p}] = [\Gamma]\{P\} - [G][\dot{p}] - \frac{d}{dt}([G][\dot{p}] + [H][\dot{p}] + \{\kappa\}) \quad (4-297)$$

Contrails

where we have

$$[G] = -2\Omega_x [G_{yz}] + 2\Omega_y [G_{xz}] - 2\Omega_z [G_{xy}] \quad (4-298)$$

$$[H] = 2\Omega_x^2 [H_{xx}] - 2\Omega_x \Omega_y [H_{xy}] - 2\Omega_x \Omega_z [H_{xz}] \\ + 2\Omega_y^2 [H_{yy}] - 2\Omega_y \Omega_z [H_{yz}] \\ + 2\Omega_z^2 [H_{zz}] \quad (4-299)$$

$$\{K\} = (\Omega_y^2 + \Omega_z^2) [A_{xy}] \{ \varphi_R \}_6 + 2\Omega_x \Omega_y [A_{yz}] \{ \varphi_R \}_5 \\ + 2\Omega_x \Omega_z [A_{xz}] \{ \varphi_R \}_4 \\ + (\Omega_x^2 + \Omega_z^2) [A_{yz}] \{ \varphi_R \}_4 \\ + 2\Omega_y \Omega_z [A_{xz}] \{ \varphi_R \}_6 \\ + (\Omega_x^2 + \Omega_y^2) [A_{xz}] \{ \varphi_R \}_5 \quad (4-300)$$

and

$$H_x = \lambda_{xx} \Omega_x + \lambda_{xy} \Omega_y + \lambda_{xz} \Omega_z + 2 \{ \beta \}' [G_{yz}] \{ \beta \} \quad (4-301)$$

$$H_y = \lambda_{xy} \Omega_x + \lambda_{yy} \Omega_y + \lambda_{yz} \Omega_z - 2 \{ \beta \}' [G_{xz}] \{ \beta \} \quad (4-302)$$

$$H_z = \lambda_{xz} \Omega_x + \lambda_{yz} \Omega_y + \lambda_{zz} \Omega_z + 2 \{ \beta \}' [G_{xy}] \{ \beta \} \quad (4-303)$$

where

$$\lambda_{xx} = I_{xx} + 2 \{ \varphi_R \}'_4 [A_{yz}] \{ \beta \} + 2 \{ \beta \}' [H_{xx}] \{ \beta \} \quad (4-304)$$

$$\lambda_{xy} = -I_{xy} + 2 \{ \varphi_R \}'_5 [A_{yz}] \{ \beta \} - \{ \beta \}' [H_{xy}] \{ \beta \} \quad (4-305)$$

$$\lambda_{xz} = -I_{xz} + 2 \{ \varphi_R \}'_4 [A_{xy}] \{ \beta \} - \{ \beta \}' [H_{xz}] \{ \beta \} \quad (4-306)$$

Contrails

$$\lambda_{yy} = I_{yy} + 2 \left(\{\varphi_R\}'_6 [A_{xy}]' + \{\varphi_R\}'_5 [A_{xz}] \right) \{p\} + 2 \{p\}' [H_{yy}] \{p\} \quad (4-307)$$

$$\lambda_{yz} = -I_{yz} + 2 \left(\{\varphi_R\}'_6 [A_{xz}] \{p\} - \{p\}' [H_{yz}] \{p\} \right) \quad (4-308)$$

$$\lambda_{zz} = I_{zz} + 2 \left(\{\varphi_R\}'_6 [A_{xy}]' + \{\varphi_R\}'_4 [A_{yz}]' \right) \{p\} + 2 \{p\}' [H_{zz}] \{p\} \quad (4-309)$$

and, finally, we have

$$F_x = \{\varphi_R\}'_1 \{p\} \quad (4-310)$$

$$F_y = \{\varphi_R\}'_2 \{p\} \quad (4-311)$$

$$F_z = \{\varphi_R\}'_3 \{p\} \quad (4-312)$$

$$G_x = \{\varphi_R\}'_4 \{p\} \quad (4-313)$$

$$G_y = \{\varphi_R\}'_5 \{p\} \quad (4-314)$$

$$G_z = \{\varphi_R\}'_6 \{p\} \quad (4-315)$$

4.2 THE COMPLETE SIMULATION OF THE DYNAMICS OF A FLEXIBLE BOOST VEHICLE DURING THE "IN-FLIGHT" PHASE

In order to completely simulate the motion and stresses of a flexible boost vehicle from launch to a point outside of the earth's atmosphere, it is necessary to supplement the equations of motion developed in Section 4.1 with detailed descriptions of the forces. In addition, the trajectory and orientation of the body are required as well as the relations giving the internal "loads" which would be required, for example, in the detailed design of the structure.

4.2.1 The Differential Equations Governing the Orientation of the Body and the Trajectory of the Center of Mass

4.2.1.1 Euler Angles for the (\hat{V} , \hat{J} , \hat{K}) Frame of Reference

It is convenient to use what are commonly called "pitch-roll-yaw" Euler angles. These angles are shown in Figure 67 and defined by the following equations:

$$\hat{i} = \cos\theta \cos\psi \hat{I} + \sin\psi \hat{J} - \sin\theta \cos\psi \hat{K} \quad (4-316)$$

$$\begin{aligned} \hat{j} = & (\sin\phi \sin\theta - \cos\phi \cos\theta \sin\psi) \hat{I} \\ & + \cos\phi \cos\psi \hat{J} \\ & + (\sin\phi \cos\theta + \cos\phi \sin\theta \sin\psi) \hat{K} \end{aligned} \quad (4-317)$$

$$\begin{aligned} \hat{k} = & (\cos\phi \sin\theta + \sin\phi \cos\theta \sin\psi) \hat{I} - \sin\phi \cos\psi \hat{J} \\ & + (\cos\phi \cos\theta - \sin\phi \sin\theta \sin\psi) \hat{K} \end{aligned} \quad (4-318)$$

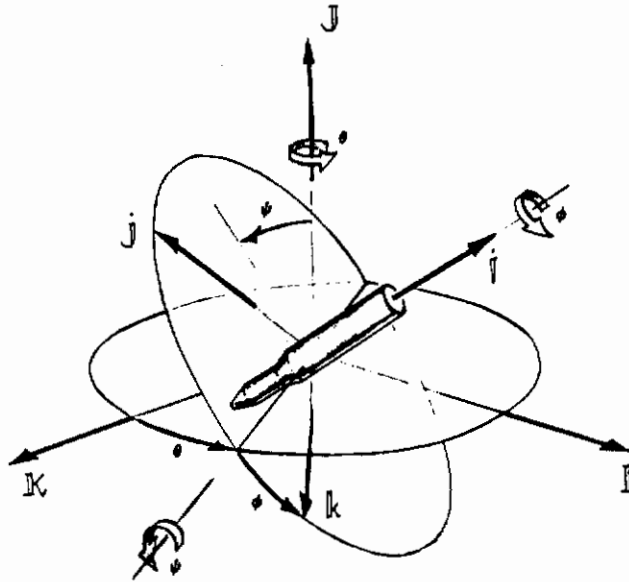

FIGURE 67 EULER ANGLES

These equations, in conjunction with Equations 4-26 and 4-157, lead to

$$\Omega_x = \dot{\varphi} + \sin \psi \dot{\theta} \tag{4-319}$$

$$\Omega_y = \cos \varphi \cos \psi \dot{\theta} + \sin \varphi \dot{\psi} \tag{4-320}$$

$$\Omega_z = \cos \varphi \dot{\psi} - \sin \varphi \cos \psi \dot{\theta} \tag{4-321}$$

Solving these equations for the Euler-angle rates, we obtain the following differential equations

$$\frac{d\varphi}{dt} = \Omega_x - \cos \varphi \tan \psi \Omega_y + \sin \varphi \tan \psi \Omega_z \tag{4-322}$$

$$\frac{d\theta}{dt} = \frac{\cos \varphi}{\cos \psi} \Omega_y - \frac{\sin \varphi}{\cos \psi} \Omega_z \tag{4-323}$$

$$\frac{d\psi}{dt} = \sin \varphi \Omega_y + \cos \varphi \Omega_z \tag{4-324}$$

4.2.1.2 Trajectory of the Center of Mass

A similar set of equations may be derived for the inertial coordinates of the center of mass. Using Equations 4-69 and 4-262, we have

$$\mathbf{V} = \frac{d\mathbf{R}}{dt} = \frac{d\xi}{dt} \mathbf{I} + \frac{d\eta}{dt} \mathbf{J} + \frac{d\zeta}{dt} \mathbf{K} \quad (4-325)$$

also,

$$\mathbf{V} = V_x \mathbf{i} + V_y \mathbf{j} + V_z \mathbf{k} \quad (4-326)$$

Using Equations 4-316, 4-317 and 4-318, we obtain

$$\begin{aligned} \frac{d\xi}{dt} = \cos\theta \cos\psi V_x + (\sin\phi \sin\theta - \cos\phi \cos\theta \sin\psi) V_y \\ + (\cos\phi \sin\theta + \sin\phi \cos\theta \sin\psi) V_z \end{aligned} \quad (4-327)$$

$$\frac{d\eta}{dt} = \sin\psi V_x + \cos\phi \cos\psi V_y - \sin\phi \cos\psi V_z \quad (4-328)$$

$$\begin{aligned} \frac{d\zeta}{dt} = -\sin\theta \cos\psi V_x + (\sin\phi \cos\theta + \cos\phi \sin\theta \sin\psi) V_y \\ + (\cos\phi \cos\theta - \sin\phi \sin\theta \sin\psi) V_z \end{aligned} \quad (4-329)$$

Integration of these first order differential equations along with Equations 4-322, 4-323, and 4-324 will result in the time history of ϕ , θ , ψ , ξ , η , and ζ ; and hence define the configuration of the "rigid body" reference at each instant of time.

4.2.2 External Forces

The generalized forces, P_1 , arising from specific "forcing functions" such as gravity, aerodynamics, and control system can be derived separately and combined in an expression for the total virtual work of external forces.

The separate expressions for the generalized forces may be derived from the virtual work contribution by $\delta p_1, \delta p_2 \dots \delta p$. The contribution of "rigid body" virtual displacements, $\delta \mathbf{R}$ and $\delta \Theta$, need not be considered since the rigid body forces, $F_x, F_y, F_z, G_x, G_y, G_z$ are related to P_1 by Equations 4-310 through 4-315. This is a distinct "conceptual" advantage (and a practical advantage from a machine computations standpoint) that results from using a redundant set of generalized coordinates. We only have to consider, then, the virtual work arising from virtual displacements, $\delta \mathbf{p}$, relative to the "rigid body" frame of reference.

4.2.2.1 Gravity Forces

If we assume that the origin is at the center of the earth and that this point is an inertial point, then the virtual work of gravity forces is given by

$$\delta W = - \int \frac{GM_0 \pi \cdot \delta p}{|\pi|^3} e dV \quad (4-330)$$

where M_0 is the mass of the earth.

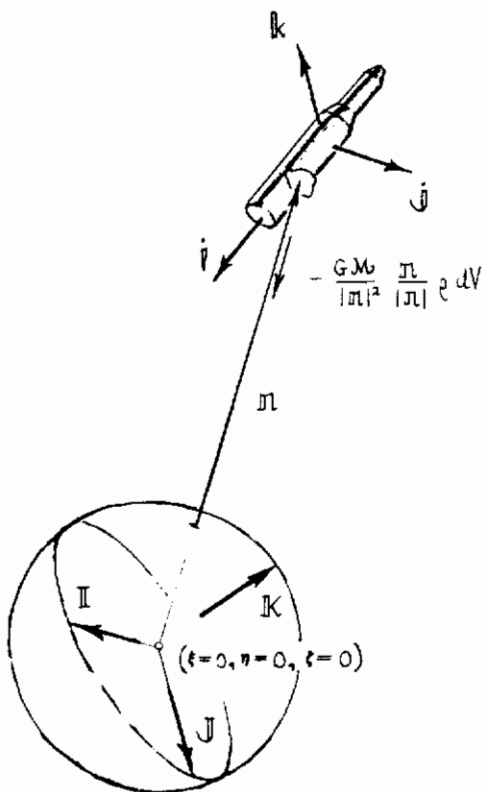

FIGURE 68 GRAVITY FORCES

In the region of integration over the body, we have the very good approximation,

$$\pi \doteq R \quad |\pi|^3 \doteq |R|^3 = R^3 \quad (4-331)$$

Contrails

where

$$R = |R| = \sqrt{\xi^2 + \eta^2 + \zeta^2} \quad (4-332)$$

so that

$$\delta W = -\frac{GM_0}{R^3} \int R \cdot \delta p \rho dV \quad (4-333)$$

From Equations 4-123, 4-124, and 4-125

$$\begin{aligned} \delta p &= \delta p_x \hat{i} + \delta p_y \hat{j} + \delta p_z \hat{k} \\ &= \{\delta p\}' \{h_x\} \hat{i} + \{\delta p\}' \{h_y\} \hat{j} + \{\delta p\}' \{h_z\} \hat{k} \end{aligned} \quad (4-334)$$

Substituting

$$\delta W = -\frac{GM_0}{R^3} \{\delta p\}' \left(\int R \cdot \hat{i} \{h_x\} \rho dV + \int R \cdot \hat{j} \{h_y\} \rho dV + \int R \cdot \hat{k} \{h_z\} \rho dV \right) \quad (4-335)$$

Using Equations 4-144 and 4-145, we can write

$$\int \{h_x\} \rho dV = [A] \{ \varphi_R \}_1 \quad (4-336)$$

$$\int \{h_y\} \rho dV = [A] \{ \varphi_R \}_2 \quad (4-337)$$

$$\int \{h_z\} \rho dV = [A] \{ \varphi_R \}_3 \quad (4-338)$$

so that the virtual work of gravity forces is given by

$$\delta W = -\frac{GM_0}{R^3} \{\delta p\}' [A] \left(\{ \varphi_R \}_1 R \cdot \hat{i} + \{ \varphi_R \}_2 R \cdot \hat{j} + \{ \varphi_R \}_3 R \cdot \hat{k} \right) \quad (4-339)$$

Contrails

where, from Equations 4-316, 4-317, and 4-318, we have

$$R \cdot \hat{i} = \xi \cos \theta \cos \psi + \eta \sin \psi - \zeta \sin \theta \cos \psi \quad (4-340)$$

$$R \cdot \hat{j} = \xi (\sin \theta \sin \theta - \cos \theta \cos \theta \sin \psi) + \eta \cos \theta \cos \psi + \zeta (\sin \theta \cos \theta + \cos \theta \sin \theta \sin \psi) \quad (4-341)$$

$$R \cdot \hat{k} = \xi (\cos \theta \sin \theta + \sin \theta \cos \theta \sin \psi) - \eta \sin \theta \cos \psi + \zeta (\cos \theta \cos \theta - \sin \theta \sin \theta \sin \psi) \quad (4-342)$$

and

$$R^2 = (\xi^2 + \eta^2 + \zeta^2)^{3/2} \quad (4-343)$$

4.2.2.2 Aerodynamic Forces

If we can idealize the vehicle by two "flat plates" as in Figure 69, then the distributed lift is

$$\frac{1}{2} \rho \omega V_0^2 C_L(x, y, t) dx dy$$

the side force is

$$\frac{1}{2} \rho \omega V_0^2 C_Y(x, z, t) dx dz$$

and the drag can be written as

$$\frac{1}{2} \rho \omega V_0^2 C_D(x, y, t) dx dy$$

Contrails

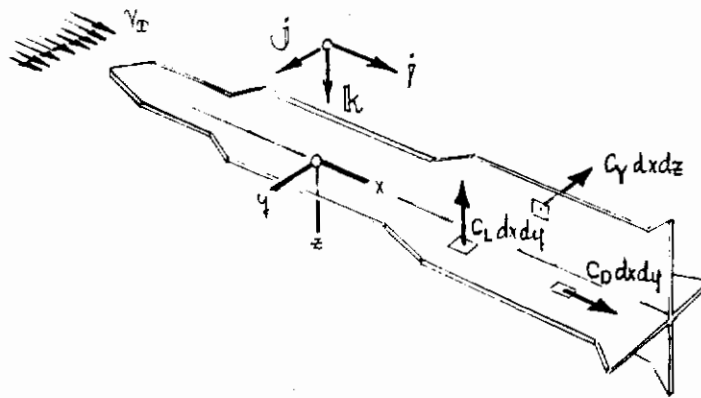

FIGURE 69 IDEALIZED DISTRIBUTION OF AERODYNAMICS FORCES

The total virtual work of aerodynamic forces is then

$$\begin{aligned}
 SW = & -\frac{1}{2}\rho v_\infty^2 \iint (C_L k - C_D i) \cdot \delta p_{z=0} dx dy \\
 & -\frac{1}{2}\rho v_\infty^2 \iint C_Y j \cdot \delta p_{y=0} dx dz
 \end{aligned} \tag{4-344}$$

The "free-stream" direction is arbitrarily taken parallel to the \dot{y} -axis. If W is the wind velocity, we have

$$v_\infty = \left(W - \frac{dR}{dt} \right) \cdot \dot{y} \tag{4-345}$$

If we assume linear, quasi-steady, aerodynamics then we have the following linear integral relations:

$$\begin{aligned}
 C_L(x, y, t) &= C_{L_0}(x, y) + \iint L(x, y; \xi, \eta) a(\xi, \eta, t) d\xi d\eta \\
 C_Y(x, z, t) &= C_{Y_0}(x, z) + \iint Y(x, z; \xi, \zeta) \theta(\xi, \zeta, t) d\xi d\zeta \\
 C_D(x, y, t) &= C_{D_0}(x, y)
 \end{aligned} \tag{4-346}$$

Contrails

where $\alpha(\xi, \eta, t)$ is the local angle-of-attack, and $\beta(\xi, \zeta, t)$ is the local angle-of-sideslip. If we introduce

$$\begin{aligned} \mu(x, y, z, t) &= \dot{i} + \frac{\partial b_j}{\partial x} j + \frac{\partial b_z}{\partial x} k \\ \nu(x, y, z, t) &= j - \frac{\partial p_y}{\partial x} \dot{i} \\ \kappa(x, y, z, t) &= k - \frac{\partial p_z}{\partial x} \dot{i} \end{aligned} \tag{4-347}$$

which is a local set of unit vectors in the deformed body, then we can write

$$\alpha(x, y, t) = - \frac{(\frac{\partial m}{\partial t} - W) \cdot \kappa}{(\frac{\partial m}{\partial t} - W) \cdot \mu}_{z=0} \tag{4-348}$$

and

$$\beta(x, z, t) = - \frac{(\frac{\partial m}{\partial t} - W) \cdot \nu}{(\frac{\partial m}{\partial t} - W) \cdot \mu}_{y=0} \tag{4-349}$$

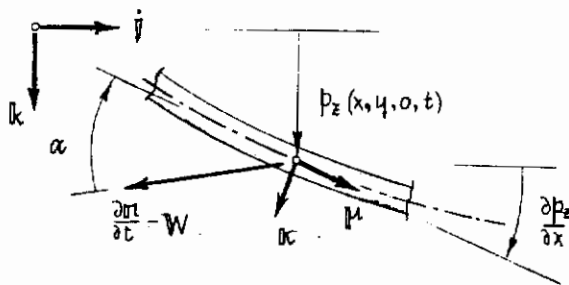

FIGURE 70 THE LOCAL ANGLE-OF-ATTACK

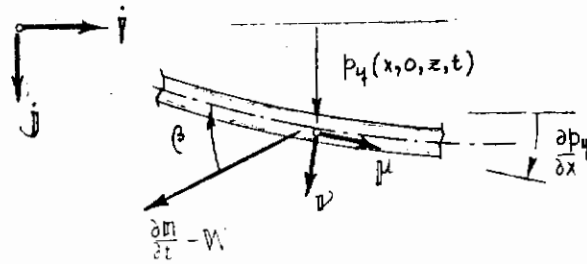

FIGURE 71 THE LOCAL ANGLE OF SIDESLIP

Now, from Equation 4-33

$$\frac{\partial \pi}{\partial t} = \frac{dR}{dt} + \Omega_x(L+p) + \dot{p} \quad (4-350)$$

and

$$\begin{aligned} (\frac{\partial \pi}{\partial t} - W) \cdot K &= -(V_x - W_x) \frac{\partial p_z}{\partial x} + (V_z - W_z) \\ &\quad - \frac{\partial p_z}{\partial x} (\Omega_y(z+p_z) - \Omega_z(y+p_y)) \\ &\quad + \Omega_x(y+p_y) - \Omega_y(x+p_x) \\ &\quad - \frac{\partial p_x}{\partial t} \frac{\partial p_z}{\partial x} + \frac{\partial p_z}{\partial t} \end{aligned} \quad (4-351)$$

$$\begin{aligned} (\frac{\partial \pi}{\partial t} - W) \cdot \pi &= -(V_x - W_x) \frac{\partial p_y}{\partial x} + (V_y - W_y) \\ &\quad - \frac{\partial p_y}{\partial x} (\Omega_y(z+p_z) - \Omega_z(y+p_y)) \\ &\quad - \Omega_x(z+p_z) + \Omega_z(x+p_x) \\ &\quad - \frac{\partial p_x}{\partial t} \frac{\partial p_y}{\partial x} + \frac{\partial p_y}{\partial t} \end{aligned} \quad (4-352)$$

Contrails

If we neglect the nonlinear terms in the small displacements, we have, approximately,

$$\begin{aligned} & \left(\frac{\partial \Pi}{\partial t} - W\right) \cdot \kappa_{z=0} \\ &= - (V_x - W_x) \frac{\partial p_z}{\partial x} + (V_z - W_z) + y \Omega_x - x \Omega_y + \frac{\partial p_z}{\partial z} \end{aligned} \quad (4-353)$$

$$\begin{aligned} & \left(\frac{\partial \Pi}{\partial t} - W\right) \cdot \nu_{y=0} \\ &= - (V_x - W_x) \frac{\partial p_y}{\partial x} + (V_y - W_y) - z \Omega_x + x \Omega_z + \frac{\partial p_y}{\partial y} \end{aligned} \quad (4-354)$$

Also, to this approximation in the expressions for α and β , we have

$$\left(\frac{\partial \Pi}{\partial t} - W\right) \cdot \mu = (V_x - W_x) = -V_\alpha \quad (4-355)$$

Substituting these expressions into Equations 4-348 and 4-349, we obtain

$$\alpha(x, y, t) = \frac{\partial p_z}{\partial z} - \frac{(V_z - W_z)}{(V_x - W_x)} - y \frac{\Omega_x}{V_\alpha} - x \frac{\Omega_y}{V_\alpha} + \frac{1}{V_\alpha} \frac{\partial p_z}{\partial t} \quad (4-356)$$

$$\beta(x, z, t) = \frac{\partial p_y}{\partial x} - \frac{(V_y - W_y)}{(V_x - W_x)} - z \frac{\Omega_x}{V_\alpha} + x \frac{\Omega_z}{V_\alpha} + \frac{1}{V_\alpha} \frac{\partial p_y}{\partial t} \quad (4-357)$$

The "rigid body" angle-of-attack and angle-of-sideslip are defined by

$$\alpha = - \frac{V_z - W_z}{V_x - W_x} \quad (4-358)$$

$$\beta = - \frac{V_y - W_y}{V_x - W_x} \quad (4-359)$$

We then have

$$\alpha(x, y, t) = \alpha + y \frac{\Omega_x}{V_\alpha} - x \frac{\Omega_y}{V_\alpha} + \frac{\partial p_z}{\partial x} + \frac{1}{V_\alpha} \frac{\partial p_z}{\partial t} \quad (4-360)$$

$$\beta(x, z, t) = \beta - z \frac{\Omega_x}{V_\alpha} + x \frac{\Omega_z}{V_\alpha} + \frac{\partial p_y}{\partial x} + \frac{1}{V_\alpha} \frac{\partial p_y}{\partial t} \quad (4-361)$$

Using Equations 4-144 and 4-145, we have

$$\begin{aligned} \alpha(x, y, t) &= \{h_z\}' \{q_R\}_3 \alpha + \{q_R\}'_4 \frac{C_x}{V_\alpha} + \{q_R\}'_5 \frac{\Omega_y}{V_\alpha} \\ &+ \{h_z\}' \{i\beta\} + \frac{1}{V_\alpha} \{h_z\}' \{i\dot{p}\} \end{aligned} \quad (4-362)$$

$$\begin{aligned}
 p(x, z, t) = \{h_y\}' \left(\{f_R\}_2 \beta + \{f_R\}_4 \frac{\Omega x}{V_0} + \{f_R\}_6 \frac{\Omega z}{V_0} \right) \\
 + \{f_R\}_5 \{p\}' + \frac{1}{V_0} \{h_y\}' \{p\}'
 \end{aligned}
 \tag{4-363}$$

The virtual work from Equation 4-344 is

$$\begin{aligned}
 \delta W = -\frac{1}{2} \rho_0 V_0^2 \iint (C_L \delta p_z - C_D \delta p_x)_{z=0} dx dy \\
 - \frac{1}{2} \rho_0 V_0^2 \iint (C_Y \delta p_y)_{y=0} dx dz \\
 = -\frac{1}{2} \rho_0 V_0^2 \{ \delta p \}' \left(\iint \{h_x\} C_L - \{h_x\} C_D \right)_{z=0} dx dy \\
 + \iint \{h_y\} C_Y \Big|_{y=0} dx dz
 \end{aligned}
 \tag{4-364}$$

Use of Equations 4-346 gives

$$\begin{aligned}
 \delta W = -\frac{1}{2} \rho_0 V_0^2 \{ \delta p \}' \left(\iint \{h_x\} C_{L0} - \{h_x\} C_{D0} \right)_{z=0} dx dy \\
 + \iint \{h_y\} C_{Y0} \Big|_{y=0} dx dz \\
 - \frac{1}{2} \rho_0 V_0^2 \{ \delta p \}' \left(\iint \{h_x\} \iint L(x, y; \xi, \eta) \alpha(\xi, \eta, t) d\xi d\eta dx dy \right. \\
 \left. + \iint \{h_y\} \iint Y(x, z; \xi, \zeta) \beta(\xi, \zeta, t) d\xi d\zeta dx dz \right)
 \end{aligned}
 \tag{4-365}$$

Substituting Equations 4-362 and 4-363 yields

$$\begin{aligned}
 \delta W = -\frac{1}{2} \rho_0 V_0^2 \{ \delta p \}' \left(\{L_0\} + [L_R] \{p\}' + \frac{1}{V_0} [L_I] \{p\}' \right) \\
 - \frac{1}{2} \rho_0 V_0^2 \{ \delta p \}' [L_I] \left(\{f_R\}_3 a + \{f_R\}_2 \beta + \{f_R\}_4 \frac{\Omega x}{V_0} \right. \\
 \left. + \{f_R\}_5 \frac{\Omega y}{V_0} + \{f_R\}_6 \frac{\Omega z}{V_0} \right)
 \end{aligned}
 \tag{4-366}$$

Contrails

where

$$\begin{aligned} \{L_0\} = & \iint \{h_z\} C_{L_0} - \{h_x\} C_{D_0} \Big|_{z=0} dx dy \\ & + \iint \{h_y\} C_{Y_0} \Big|_{y=0} dx dz \end{aligned} \quad (4-367)$$

$$\begin{aligned} [L_R] = & \iiint \{h_z\} \left\{ \frac{\partial h_z}{\partial x} \right\}' L(x, y, z; \xi, \eta) d\xi dy dx dy \\ & + \iiint \{h_y\} \left\{ \frac{\partial h_y}{\partial y} \right\}' Y(x, z; \xi, \eta) d\xi dz dx dz \end{aligned} \quad (4-368)$$

$$\begin{aligned} [L_I] = & \iiint \{h_z\} \{h_z\}' L(x, y; \xi, \eta) d\xi dy dx dy \\ & + \iiint \{h_y\} \{h_y\}' Y(x, z; \xi, \eta) d\xi dz dx dz \end{aligned} \quad (4-369)$$

and use has been made of Equations 4-144 and 4-145.

4.2.2.3 Thrust Forces

General consideration of the distributed thrust forces is simplified because it can be assumed that they do not depend explicitly on the orientation of the "rigid body" reference. That is, they do not depend on $\xi, \eta, \zeta, \phi, \theta$ or ψ . There is one exception to this, in that the ambient pressure, p_∞ , depends on altitude, $\sqrt{\xi^2 + \eta^2 + \zeta^2}$, and the thrust forces are slightly influenced by the ambient pressure in the neighborhood of the rocket exhaust. On the basis that the generalized coordinates, $p_1, p_2 \dots p_N$, are "small," the following general linear expression can be assumed for the thrust forces.

$$\delta W = - \{ \delta p \}' \left(\{ H_0 \} + [H] \{ p \} \right) \quad (4-370)$$

where the coefficients $\{ H_0 \}$ and $[H]$ depend linearly on p_∞

The two important variations of thrust distribution with the generalized coordinates are:

- o Change in thrust direction with body bending, and
- o Change in thrust direction due to gimbaling of motor nozzles.

4.2.2.4 Control System Forces

It will be assumed that there are only three primary control coordinates: a roll control coordinate, μ ; a pitch control coordinate, γ ; and a yaw control coordinate, λ . All three of these are related to the generalized coordinates describing the instantaneous configuration of the body relative to the rigid reference frame.

$$\mu = \{\eta_\mu\} \{p\} \quad (4-371)$$

$$\delta = \{\eta_\delta\} \{p\} \quad (4-372)$$

$$\lambda = \{\eta_\lambda\} \{p\} \quad (4-373)$$

The servos that operate the control mechanisms exert forces on the structure. The virtual work of these forces is

$$\delta W = \delta \mu M + \delta \delta \Gamma + \delta \lambda \Lambda \quad (4-374)$$

The general statement of a "control law" specifies how M , Γ , and Λ depend on the outputs of sensors in the control system.

Substitution of Equations 4-371, 4-372, and 4-373 into Equation 4-374 gives the following expression for the virtual work of servo forces.

$$\delta W = \{\delta p\}' \left(\{\eta_\mu\} M + \{\eta_\delta\} \Gamma + \{\eta_\lambda\} \Lambda \right) \quad (4-375)$$

4.2.2.5 Summary of External Generalized Forces

In summary, the generalized forces defined in Equation 4-78 are obtained by adding the virtual work of the separate forces (Equations 4-339, 4-366, 4-370, and 4-375) to obtain

$$\delta W = \{\delta p\}' \{P\}$$

where

$$\begin{aligned} \{P\} = & -\frac{1}{2} \rho v_\infty^2 \left([L_A] \{P\} + [L_I] \left(\{\varphi_R\}_3 \alpha + \{\varphi_R\}_2 \beta \right. \right. \\ & + \{\varphi_R\}_4 \frac{\alpha_\lambda}{V_\infty} + \{\varphi_R\}_5 \frac{\alpha_\delta}{V_\infty} + \{\varphi_R\}_6 \frac{\alpha_\lambda}{V_\infty} + \frac{1}{V_\infty} \{\dot{P}\} \left. \right) + [L_o] \\ & - ([H] \{P\} + \{H_o\}) \\ & - GM [A] \left(\frac{\xi \cos \theta \cos \psi + \eta \sin \psi - \zeta \sin \theta \cos \psi}{(\xi^2 + \eta^2 + \zeta^2)^{3/2}} \{\varphi_R\}_1 \right. \\ & + \frac{\xi (\sin \psi \sin \theta - \cos \psi \cos \theta \sin \psi) + \eta \cos \psi \cos \psi + \zeta (\sin \psi \cos \theta + \cos \psi \sin \theta \sin \psi)}{(\xi^2 + \eta^2 + \zeta^2)^{3/2}} \{\varphi_R\}_2 \\ & + \left. \frac{\xi (\cos \psi \sin \theta + \sin \psi \cos \theta \sin \psi) - \eta \sin \psi \cos \psi + \zeta (\cos \psi \cos \theta - \sin \psi \sin \theta \sin \psi)}{(\xi^2 + \eta^2 + \zeta^2)^{3/2}} \{\varphi_R\}_3 \right) \\ & + \{\eta_\mu\} M + \{\eta_\delta\} \Gamma + \{\eta_\lambda\} \Lambda \end{aligned} \quad (4-376)$$

4.2.3 The Transformation to Modal Coordinates

In order to judiciously reduce the number of degrees-of-freedom, we consider Equations 4-297 in the case where

$$[\Gamma][A]\ddot{\beta} = -[K]\beta - [B]\dot{\beta} + \{P\} \quad (4-377)$$

Further, in order to derive the modes of free vibration, we consider the dissipation and external forces to be zero.

$$[\Gamma][A]\ddot{\beta} = -[K]\beta \quad (4-378)$$

It will be convenient also to have a set of vibration modes with locked controls so that

$$\mu = \{\eta_\mu\}'\{\beta\} = 0 \quad (4-379)$$

$$\nu = \{\eta_\nu\}'\{\beta\} = 0 \quad (4-380)$$

$$\lambda = \{\eta_\lambda\}'\{\beta\} = 0 \quad (4-381)$$

A set of influence coefficients for the restrained system with locked controls can be derived in the form

$$[E] = [S](\{S\}'[K][S])^{-1}\{S\}' \quad (4-382)$$

where $[S]$ is a constraint matrix that constrains the rigid body motion as well as the control motion. Then, from relations developed in Paragraph 2.2.3.4

$$\{\beta\} = -[\Gamma]'[E][\Gamma][A]\ddot{\beta} \quad (4-383)$$

separating variables,

$$\{\beta\} = \{\varphi\}q \quad (4-384)$$

leads to the eigenvalue problem:

$$[\Gamma]'[E][\Gamma][A]\ddot{\varphi} = \lambda \{\varphi\} \quad (4-385)$$

Controls

whose solutions are the elastic modes and frequencies with locked controls

$$\{\phi\}_i, \omega_i = \sqrt{\frac{1}{\lambda_i}} \quad i = 1, 2, \dots \quad (4-386)$$

The control modes are any values of the generalized coordinates representing displacements of the rigid system with a unit displacement in the control coordinate. Such a displacement is

$$\{p\} = \{\varphi_R\}_7 \mu + \{\varphi_R\}_8 \beta + \{\varphi_R\}_9 \lambda \quad (4-387)$$

which are "rigid body" modes in the sense

$$[K]\{\varphi_R\}_7 = [K]\{\varphi_R\}_8 = [K]\{\varphi_R\}_9 = \{0\} \quad (4-388)$$

These modes are not necessarily orthogonal to the rigid body modes, but a set can be constructed which is orthogonal to the rigid body modes. The derivation is similar to that in Paragraph 3.1.3.5, in particular, Equation 3-516.

$$\{\varphi_\mu\} = [\Gamma]'\{\varphi_R\}_7 \quad (4-389)$$

$$\{\varphi_\beta\} = [\Gamma]'\{\varphi_R\}_8 \quad (4-390)$$

$$\{\varphi_\lambda\} = [\Gamma]'\{\varphi_R\}_9 \quad (4-391)$$

We then consider the following transformation of coordinates

$$\begin{aligned} \{p\} &= \{\varphi\}_1 q_1 + \{\varphi\}_2 q_2 + \dots + \{\varphi\}_m q_m \\ &\quad + \{\varphi_\mu\} \mu + \{\varphi_\beta\} \beta + \{\varphi_\lambda\} \lambda \\ &= [\varphi] \{q\} \end{aligned} \quad (4-392)$$

where

$$[\varphi] = [\{\varphi\}_1, \{\varphi\}_2, \dots, \{\varphi\}_m, \{\varphi_\mu\}, \{\varphi_\beta\}, \{\varphi_\lambda\}]$$

and

$$\{q\} = \begin{bmatrix} q_1 \\ q_2 \\ \vdots \\ q_m \\ \mu \\ \beta \\ \lambda \end{bmatrix} \quad (4-393)$$

Contrails

The new coordinates satisfy the constraints, Equation 4-225, explicitly.

If we make this change of coordinates in Equations 4-295 and 4-296, we obtain

$$\begin{aligned}\{\dot{n}\} = & -[\varphi]'[G][\varphi]H\dot{q}\} + [\varphi]'[H][\varphi]H\dot{q}\} \\ & -[\varphi]'[K][\varphi]Hq\} + [\varphi]'\{K\} \\ & -[\varphi]'[B][\varphi]H\dot{q}\} + \{Q\}\end{aligned}\quad (4-394)$$

where

$$\{n\} \equiv [\varphi]'[A][\varphi]H\dot{q}\} + [\varphi]'[G][\varphi]H\dot{q}\} \quad (4-395)$$

and

$$\{Q\} = [\varphi]'\{P\} \quad (4-396)$$

4.2.4 Transient Loads and Stresses

In the analysis of the structure by either the complementary energy method or the direct stiffness method (see Paragraph 5.1.1), there are two important results. First, the determination of the influence coefficients which are defined by the strain energy in terms of the generalized forces associated with the generalized coordinates $P_1, P_2 \dots P_N$.

$$U = \frac{1}{2} \{P\}'[E]\{P\} \quad (4-397)$$

(When the body is unrestrained, arbitrary constraints must be imposed to prevent rigid body motion and

$$[E] = [S]([S]'[K][S])'[S]'$$

as discussed in Paragraph 2.2.3.4)

Second, the determination of the coefficients relating internal stress resultants (or "member loads") to the generalized forces, P_1 .

$$\{L\} = [R]\{P\} \quad (4-398)$$

The stress resultants, L_i , may be shears, moments, or torques in structural members like beams, plates, shells, and rods representing idealized portions of a complex built-up structure. In the case of a simply determinate structure, $[R]$ depends only on the geometry of the structure (see, for example,

Paragraph 3.1.2.1, Equations 3-78 and 3-79). For a redundant structure, however, $[R]$ depends also on the elastic characteristics of the system.

It is perhaps, intuitively clear that Equation 4-398 would lead to

$$\{L\} = [R][K]\{p\} + [R][B]\{\dot{p}\} \quad (4-399)$$

although this is very difficult to show systematically (see Paragraph 5.1.1.1 and the discussion leading to Equation 5-54).

From Equation 4-295, we have

$$\begin{aligned} [K]\{p\} + [B]\{\dot{p}\} \\ = [P]\{\dot{p}\} - [G]\{\dot{p}\} + [H]\{\dot{p}\} + \{K\} - \{\dot{h}\} \end{aligned} \quad (4-400)$$

Substituting this into Equation 4-399 using Equations 4-296 and 4-392, we obtain

$$\begin{aligned} \{L\} = [R][P]\{\dot{p}\} - 2[G]\{\dot{p}\} + [H]\{\dot{p}\} \\ - ([G]\{\dot{p}\} - [A]\{\dot{p}\} - \{K\}) \end{aligned} \quad (4-401)$$

4.2.5 Final Equations of Motion

A summary of the equations of motion is given in Figure 72 for the case where the centrifugal and Coriolis effects of elastic deflection are neglected. In these equations a set of rigid modes which are mutually orthogonal has been introduced. The procedure for constructing such a set of modes belongs to the theory of the inertia dyadic for a rigid body. The orthogonal rigid body modes are denoted by:

$$\{\psi_s\}, \{\psi_r\}, \{\psi_s\}, \{\psi_\theta\}, \{\psi_\phi\}, \text{ and } \{\psi_\psi\} \quad (4-402)$$

Using the orthogonality properties of the rigid body modes, it can be shown that the gravity forces only influence the "translation" equations. The generalized forces, P_i , in Figure 72 have been redefined to take advantage of this.

$$\begin{aligned}
 \frac{dV_x}{dt} &= \Omega_z V_y - \Omega_y V_z - \frac{GM_0}{M} \frac{\xi \cos \theta \cos \psi + \eta \sin \psi - \zeta \sin \theta \cos \psi}{(\zeta^2 + \eta^2 + \zeta^2)^{3/2}} + \frac{1}{M} \{ \varphi_2 \} \{ P \} \\
 \frac{dV_y}{dt} &= \Omega_x V_z - \Omega_z V_x - \frac{GM_0}{M} \frac{\xi (\sin \varphi \sin \theta - \cos \varphi \cos \theta \sin \psi) + \eta (\cos \varphi \cos \psi) + \zeta (\sin \varphi \cos \theta + \cos \varphi \sin \theta \sin \psi)}{(\zeta^2 + \eta^2 + \zeta^2)^{3/2}} + \frac{1}{M} \{ \varphi_1 \} \{ P \} \\
 \frac{dV_z}{dt} &= \Omega_y V_x - \Omega_x V_y - \frac{GM_0}{M} \frac{\xi (\cos \varphi \sin \theta + \sin \varphi \cos \theta \sin \psi) - \eta (\sin \varphi \cos \psi) + \zeta (\cos \varphi \cos \theta - \sin \varphi \sin \theta \sin \psi)}{(\zeta^2 + \eta^2 + \zeta^2)^{3/2}} + \frac{1}{M} \{ \varphi_3 \} \{ P \} \\
 \frac{d\Omega_x}{dt} &= \frac{I_{yy} - I_{zz}}{I_{xx}} \Omega_z \Omega_y + \frac{1}{I_{xx}} \{ \varphi_4 \} \{ P \} \\
 \frac{d\Omega_y}{dt} &= \frac{I_{zz} - I_{xx}}{I_{yy}} \Omega_z \Omega_x + \frac{1}{I_{yy}} \{ \varphi_5 \} \{ P \} \\
 \frac{d\Omega_z}{dt} &= \frac{I_{xx} - I_{yy}}{I_{zz}} \Omega_y \Omega_x + \frac{1}{I_{zz}} \{ \varphi_6 \} \{ P \} \\
 \frac{d\xi}{dt} &= \cos \theta \cos \psi V_x + (\sin \varphi \sin \theta - \cos \varphi \cos \theta \sin \psi) V_y + (\cos \varphi \sin \theta + \sin \varphi \cos \theta \sin \psi) V_z \\
 \frac{d\eta}{dt} &= \sin \psi V_x + \cos \varphi \cos \psi V_y - \sin \varphi \cos \psi V_z \\
 \frac{d\zeta}{dt} &= -\sin \theta \cos \psi V_x + (\sin \varphi \cos \theta + \cos \varphi \sin \theta \sin \psi) V_y + (\cos \varphi \cos \theta - \sin \varphi \sin \theta \sin \psi) V_z \\
 \frac{d\varphi}{dt} &= \Omega_x - \cos \varphi \tan \psi \Omega_y + \sin \varphi \tan \psi \Omega_z \\
 \frac{d\theta}{dt} &= \frac{\cos \varphi}{\cos \psi} \Omega_y - \frac{\sin \varphi}{\cos \psi} \Omega_z \\
 \frac{d\psi}{dt} &= \sin \varphi \Omega_y + \cos \varphi \Omega_z
 \end{aligned}$$

$$[MH\dot{q}] + [RH\dot{q}] + [FHq] = [\varphi] \{ P \}$$

$$\begin{aligned}
 \alpha &= - \frac{W_z - V_z}{W_x - V_x} \\
 \beta &= - \frac{W_y - V_y}{W_x - V_x}
 \end{aligned}$$

$$\begin{aligned}
 \{ P \} &= - \frac{1}{2} \rho v_0^2 ([L_R] \{ P \} + \{ L_0 \}) \\
 &\quad - \frac{1}{2} \rho v_0^2 [L_I] (\{ \varphi_1 \} \alpha + \{ \varphi_2 \} \beta + \{ \varphi_3 \} \frac{\Omega_x}{v_0} + \{ \varphi_4 \} \frac{\Omega_y}{v_0} + \{ \varphi_5 \} \frac{\Omega_z}{v_0}) \\
 &\quad - ([H] \{ p \} + \{ H_0 \}) + \{ \eta_1 \} M + \{ \eta_2 \} \Gamma + \{ \eta_3 \} \Delta
 \end{aligned}$$

$$\begin{aligned}
 W_x &= \cos \theta \cos \psi W_\xi + \sin \psi W_\eta - \sin \theta \cos \psi W_\zeta \\
 W_y &= (\sin \varphi \sin \theta - \cos \varphi \cos \theta \sin \psi) W_\xi + \cos \varphi \cos \psi W_\eta + (\sin \varphi \cos \theta + \cos \varphi \sin \theta \sin \psi) W_\zeta \\
 W_z &= (\cos \varphi \sin \theta + \sin \varphi \cos \theta \sin \psi) W_\xi - \sin \varphi \cos \psi W_\eta + (\cos \varphi \cos \theta - \sin \varphi \sin \theta \sin \psi) W_\zeta
 \end{aligned}$$

$$v_0 = W_x - V_x$$

$$\{ L \} = [R][\Gamma] \{ P \} - [A][\varphi H \dot{q}]$$

FIGURE 72 EQUATIONS FOR THE GENERAL MOTION OF A FLEXIBLE LAUNCH VEHICLE

5.0 METHODS TO OBTAIN VIBRATION MODES
FOR LARGE REDUNDANTLY COUPLED STRUCTURES

Contrails

5.1 THE PROBLEM OF VIBRATION ANALYSIS IN ANALYTICAL MECHANICS

In the light of the general principles of analytical mechanics, the problem of vibration analysis is distinctly divided into two problems of lesser scope. The first problem involves the consideration of the strain energy of the system, which defines the stiffness matrix or the matrix of structural influence coefficients. The second problem involves consideration of the kinetic energy of the system, which defines the inertia matrix. The problem of vibrations in these general terms has been considered in Section 2.2.

In Paragraph 5.1.1 below, we want to consider the first of these problems. We shall use the term "structural analysis" to mean the determination of structural influence coefficients as well as the determination of the transformation matrix which defines the internal stress resultants or "member" loads in terms of the applied generalized forces.

In Paragraph 5.1.2, we turn to the second problem in vibrations and consider some techniques for deriving inertia matrices for specific types of structures.

We shall restrict our attention, in this section, to the linear analysis of structures because the general theory of vibrations is predicated on the assumption of linear motions from an equilibrium position. This is not intended to imply, however, that the problem of large deflections is unimportant in strength calculations for some flexible aerospace structures.

5.1.1 General Methods of Structural Analysis

The general study of the deformation of linear structures is largely divided into two basic methods. The first method deals with the strain energy expressed in terms of generalized coordinates and is commonly called the "Direct Stiffness" method (or "Matrix-Displacement" method). The second method deals with the strain energy expressed in terms of applied loads and is commonly called the "Complementary Energy" method (or "Matrix-Force" method).

Both of these basic methods can be applied in a routine manner to arbitrary linear structures and both methods have their advantages and disadvantages. It can be safely said that any problem that can be worked by one method can be worked by the other method. The equivalence in generality of the two approaches is demonstrated in Paragraphs 5.1.1.1 and 5.1.1.2.

Both methods employ the philosophy of dividing a complicated structure into a number of small, simple, structural elements for which the stiffness properties are known. The following definitions are appropriate for both methods:

"element" - one- or two-dimensional structure whose motion and stress-state are well defined by loads acting only at the "ends."
An element is a subdivision of a member.

"member" - a piece of a structure with no redundant load paths. A member is a subdivision of the whole structure.

The mode of subdivision is arbitrary and is left, somewhat, to engineering judgement.

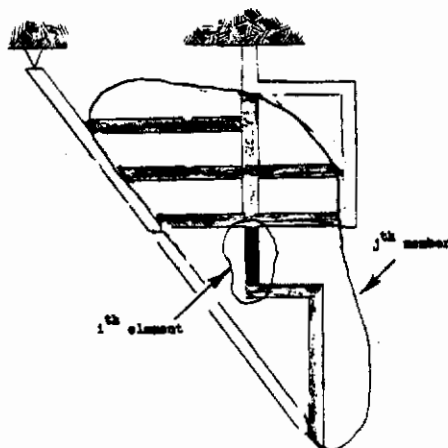

FIGURE 73. SUBDIVISIONS OF STRUCTURE INTO "MEMBERS" AND "ELEMENTS"

If u is the specific internal energy of a particle of the structure, the total strain energy of the whole structure is

$$U = \int u dV \quad (5-1)$$

This leads to the important additive property that the total strain energy is the sum of the energy of the members which is in turn the sum of the energies of the elements. That is, if

$$U_{ij} = \int_{(ij)} u dV \quad (5-2)$$

Contrails

where

$$\int_{(i,j)} \dots dV \quad (5-3)$$

is an integration over the region occupied by the i^{th} element of the j^{th} member then, since

$$\int () dV = \sum_j \sum_i \int_{(i,j)} () dV \quad (5-4)$$

we have

$$U = \sum_j \sum_i U_{ij} \quad (5-5)$$

Now, if $\{q\}_{ij}$ is a set of generalized coordinates which describe the configuration of the i^{th} element of the j^{th} member, then we know that the strain energy of this element is of the general form:

$$U_{ij} = \frac{1}{2} \{q\}'_{ij} [F]_{ij} \{q\}_{ij} \quad (5-6)$$

which defines the element stiffness matrix, $[F]_{ij}$. This matrix is, in general, singular because the coordinates, $\{q\}_{ij}$, describe a general motion of the element, in particular, rigid body motion. If we introduce a constraint to prevent rigid body motion, then we may derive an element influence matrix in the form:

$$[G]_{ij} = ([S]'_{ij} [F]_{ij} [S]_{ij})^{-1} \quad (5-7)$$

From equilibrium of loads on the free element, we can derive a transformation which eliminates some of the loads. Such a transformation can be used to obtain an unrestrained stiffness matrix from the element influence matrix

$$[F]_{ij} = [V]'_{ij} [G]_{ij} [V]_{ij} \quad (5-8)$$

Using Lagrange's equations,

$$\frac{\partial U_{ij}}{\partial q_k} = Q_k \quad (5-9)$$

we obtain, from Equation 5-6,

$$[F]_{ij} \{q\}_{ij} = \{Q\}_{ij} \quad (5-10)$$

or, subject to the constraint of rigid body motion (see Paragraph 2.2.3.4),

$$\{q\}_{ij} = [S]_{ij} ([S]'_{ij} [F]_{ij} [S]_{ij})^{-1} [S]'_{ij} \{Q\}_{ij} \quad (5-11)$$

If we introduce the internal stress resultants:

$$\{L\}_{ij} = [S]_{ij}' \{Q\}_{ij} \quad (5-12)$$

Then we can write

$$\{Q\}_{ij} = [S]_{ij} [G]_{ij} \{L\}_{ij} \quad (5-13)$$

Substitution into Equation 5-6 gives

$$U_{ij} = \frac{1}{2} \{L\}_{ij}' [G]_{ij}' [S]_{ij}' [F]_{ij} [S]_{ij} [G]_{ij} \{L\}_{ij} \quad (5-14)$$

but

$$[G]_{ij}' [S]_{ij}' [F]_{ij} [S]_{ij} = [1] \quad (5-15)$$

so that

$$U_{ij} = \frac{1}{2} \{L\}_{ij}' [G]_{ij} \{L\}_{ij} \quad (5-16)$$

which is the element strain energy in terms of internal stress resultants.

It may be worthwhile to mention that the above "complementary energy" expression depends on the arbitrary constraints imposed on the element. The representation in Equation 5-6, however, is unique and, in a sense, more basic than Equation 5-16.

5.1.1.1 The Direct Stiffness Method

The aggregate of all the coordinates of all the elements of all the members represents a set of "internal" coordinates which are not consistent with the kinematic constraints demanding displacement and slope continuity between adjacent elements. For each member we can make a transformation which introduces the proper constraints between elements. If $\{q\}_j$ is a set of generalized coordinates for the j^{th} member which is consistent with all the constraints on the j^{th} member, then there is a transformation of the form

$$\{q\}_{ij} = [r]_{ij} \{q\}_j \quad (5-17)$$

The matrix of the transformation is called the element compatibility matrix. Figure 74 illustrates the typical procedure for deriving the compatibility matrices.

$$\begin{bmatrix} q_{i,j} \\ q_{i+1,j} \end{bmatrix} = \begin{bmatrix} 1 \\ 1 \end{bmatrix} q_j$$

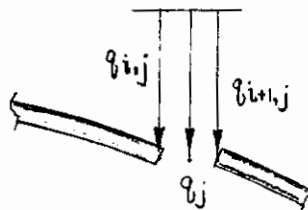

FIGURE 74 DISPLACEMENT CONTINUITY AT A JOINT BETWEEN ELEMENTS OF A MEMBER

Contrails

If Equation 5-17 is substituted into Equation 5-6, we obtain

$$u_{ij} = \frac{1}{2} \{q\}'_j [T]'_{ij} [F]_{ij} [T]_{ij} \{q\}_j \quad (5-18)$$

The total strain energy in the j^{th} member is then

$$u_j = \sum_i u_{ij} = \frac{1}{2} \{q\}'_j \sum_i [T]'_{ij} [F]_{ij} [T]_{ij} \{q\}_j \quad (5-19)$$

or

$$u_j = \frac{1}{2} \{q\}'_j [F]_j \{q\}_j \quad (5-20)$$

where

$$[F]_j = \sum_i [T]'_{ij} [F]_{ij} [T]_{ij} \quad (5-21)$$

which is the "composite" stiffness matrix of the j^{th} member. Finally, we introduce the constraints between members. If $\{q\}$ is a set of coordinates consistent with the constraints in the whole structure, then there exists a compatibility transformation of the form

$$\{q\}_j = [T]_j \{q\} \quad (5-22)$$

such that the total strain energy in the whole structure is

$$U = \sum_j u_j = \frac{1}{2} \{q\}' \sum_j [T]'_j [F]_j [T]_j \{q\} \quad (5-23)$$

or

$$U = \frac{1}{2} \{q\}' [F] \{q\} \quad (5-24)$$

where

$$[F] = \sum_j [T]'_j [F]_j [T]_j \quad (5-25)$$

In the process of eliminating coordinates to insure structural continuity, the final composite set of generalized coordinates is far more than the number necessary to describe the "external" configuration of the structure. If p_i , $i = 1, 2, \dots, N$, is a subset of the q 's that are sufficient to describe the external configuration of the system, then the number of degrees-of-freedom may be reduced by assuming that the "internal" applied loads are zero. If the coordinates are arranged so that

$$\{q_1\} = \{p\}; \quad \{q\} = \begin{bmatrix} \{q_1\} \\ \{q_2\} \end{bmatrix} \quad (5-26)$$

and $\{q_2\}$ is the set of coordinates to be eliminated, then Equation 5-24 is partitioned so that

$$U = \frac{1}{2} \begin{bmatrix} \{q_1\}' & \{q_2\}' \end{bmatrix} \begin{bmatrix} [F_{11}] & [F_{12}] \\ [F_{21}] & [F_{22}] \end{bmatrix} \begin{bmatrix} \{q_1\} \\ \{q_2\} \end{bmatrix} \quad (5-27)$$

Constraints

The generalized forces associated with $\{q_2\}$ are the "internal" applied loads which are assumed to be zero.

$$\{Q_2\} = \left\{ \frac{\partial U}{\partial q_2} \right\} = [F_{21}] \{q_1\} + [F_{22}] \{q_2\} = \{0\} \quad (5-28)$$

Subject to this constraint, we have

$$\{q_2\} = -[F_{22}]^{-1} [F_{21}] \{q_1\} \quad (5-29)$$

or

$$\begin{Bmatrix} \{q_1\} \\ \{q_2\} \end{Bmatrix} = \begin{bmatrix} [r_1] \\ -[F_{22}]^{-1} [F_{21}] \end{bmatrix} \{p\} \quad (5-30)$$

or, finally,

$$\{q\} = [T] \{p\} \quad (5-31)$$

where

$$[T] = \begin{bmatrix} [r_1] \\ -[F_{22}]^{-1} [F_{21}] \end{bmatrix} \quad (5-32)$$

Substituting Equation 5-30 into Equation 5-27 gives

$$U = \frac{1}{2} \{p\}' \begin{bmatrix} [r_1] & -[F_{21}]^{-1} [F_{22}] \end{bmatrix} \begin{bmatrix} [F_{11}] & [F_{12}] \\ [F_{21}] & [F_{22}] \end{bmatrix} \begin{bmatrix} [r_1] \\ -[F_{22}]^{-1} [F_{21}] \end{bmatrix} \{p\} \quad (5-33)$$

or

$$U = \frac{1}{2} \{p\}' [K] \{p\} \quad (5-34)$$

where the stiffness matrix for the structure is given by

$$[K] = [F_{11}] - [F_{12}] [F_{22}]^{-1} [F_{21}] \quad (5-35)$$

The structural influence coefficients of the system are given by

$$[E] = [K]^{-1} \quad (5-36)$$

if the structure is constrained. If the structure is not constrained, a set of influence coefficients can be derived for an arbitrary constraint which is just sufficient to prevent rigid body motion (see Paragraph 2.2.3.4).

$$[E] = [S] ([S]' [K] [S])^{-1} [S]' \quad (5-37)$$

For statically applied loads, we may relate the internal stress resultants

$$\{L_{ij}\} = [S]'_{ij} \{Q\}_j \quad (5-38)$$

to the externally applied loads, $\{P\}$, which are the generalized forces associated with the generalized coordinates, $\{p\}$. This is done in the following manner. By successive substitution of Equations 5-10, 5-17, 5-22, and 5-31 into 5-38, we have

Contrails

$$\begin{aligned}
 \{L\}_{ij} &= [S]_{ij}' \{Q\}_{ij} \\
 &= [S]_{ij}' [F]_{ij} \{q\}_{ij} \\
 &= [S]_{ij}' [F]_{ij} [T]_{ij} \{q\}_j \\
 &= [S]_{ij}' [F]_{ij} [T]_{ij} [T]_j \{q\} \\
 &= [S]_{ij}' [F]_{ij} [T]_{ij} [T]_j [T] \{p\} \\
 &= [S]_{ij}' [F]_{ij} [T]_{ij} [T]_j [T] [E] \{P\}
 \end{aligned} \tag{5-39}$$

The last substitution, based on

$$\{p\} = [E] \{P\} \tag{5-40}$$

is valid for restrained or unrestrained systems because in the general solution (see Equation 2-245 in Paragraph 2.2.3.4) the rigid body portion does not contribute to the stress resultants. All of the pertinent internal reactions for computing stresses for a given external loading can be selected from the aggregate of the $\{L\}_{ij}$ for all the elements of all the members. These can then be related by a single transformation by using Equation 5-39.

$$\{L\} = [R] \{P\} \tag{5-41}$$

where $\{L\}$ is a matrix whose elements have been selected from all of the $\{L\}_{ij}$ and the rows of $[R]$ are the corresponding rows from the matrices

$$[S]_{ij}' [F]_{ij} [T]_{ij} [T]_j [T] [E] \tag{5-42}$$

For dynamically applied loads, we have from Lagrange's equations for an element

$$\{Q\}_{ij} = [F]_{ij} \{q\}_{ij} + [R]_{ij} \{\dot{q}\}_{ij} + [M]_{ij} \{\ddot{q}\}_{ij} \tag{5-43}$$

and the stress resultants are

$$\begin{aligned}
 \{L\}_{ij} &= [S]_{ij}' \{Q\}_{ij} \\
 &= [S]_{ij}' [F]_{ij} \{q\}_{ij} + [S]_{ij}' [R]_{ij} \{\dot{q}\}_{ij}
 \end{aligned} \tag{5-44}$$

where the inertia terms are presumed to vanish on the basis that the stress resultants depend only on the strains and strain rates (see also Paragraph 4.1.4, Equations 4-193 through 4-198). Now, as in the static case,

$$\{q\}_{ij} = [T]_{ij} [T]_j [T] \{p\} \tag{5-45}$$

and, by differentiating

$$\{\dot{q}\}_{ij} = [T]_{ij} [T]_j [T] \{\dot{p}\} \tag{5-46}$$

Substituting these into Equation 5-44 gives

$$\begin{aligned}
 \{L\}_{ij} &= [S]_{ij}' [F]_{ij} [T]_{ij} [T]_j [T] \{p\} \\
 &\quad + [S]_{ij}' [F]_{ij} [T]_{ij} [T]_j [T] \{\dot{p}\}
 \end{aligned} \tag{5-47}$$

Contrails

If we introduce

$$r_1 = [K] \{k\} \quad (5-48)$$

in the first term and

$$r_2 = [B] \{b\} \quad (5-49)$$

in the second term, then

$$\begin{aligned} \{L\}_{ij} &= ([S]_{ij}' [F]_{ij} [T]_{ij} [T]_j [T] [K]^{-1}) \{k\} \{b\} \\ &+ ([S]_{ij}' [R]_{ij} [T]_{ij} [T]_j [T] [B]^{-1}) [B] \{b\} \end{aligned} \quad (5-50)$$

Now in the simple case:

$$[R]_{ij} = \rho [F]_{ij} \quad (5-51)$$

we have

$$\begin{aligned} [B] &= \sum_i \sum_j [T]' [T]_j' [T]_{ij}' [R]_{ij} [T]_{ij} [T]_j [T] \\ &= \rho \sum_i \sum_j [T]' [T]_j' [T]_{ij}' [F]_{ij} [T]_{ij} [T]_j [T] \\ &= \rho [K] \end{aligned} \quad (5-52)$$

so that

$$\begin{aligned} [S]_{ij}' [R]_{ij} [T]_{ij} [T]_j [T] [B]^{-1} \\ = [S]_{ij}' [F]_{ij} [T]_{ij} [T]_j [T] [K]^{-1} \end{aligned} \quad (5-53)$$

If we suppose this to be generally true, then

$$\{L\}_{ij} = [S]_{ij}' [F]_{ij} [T]_{ij} [T]_j [T] [E] (\{k\} \{b\} + [B] \{b\})$$

or, for the pertinent internal stress resultants, we have

$$\{L\} = [R] (\{k\} \{b\} + [B] \{b\}) \quad (5-54)$$

where $[R]$ is the same matrix that appears in Equation 5-41. It is felt intuitively that this could be proved to be true without making the assumption in Equation 5-51.

5.1.1.2 The Complementary Energy Method

The fundamental starting point for the complementary energy method is Equation 5-16

$$u_{ij} = \frac{1}{2} \{L\}_{ij}' [G]_{ij} \{L\}_{ij} \quad (5-55)$$

In this equation the stress resultants in an element can be related to the applied loads and reactions on the whole member to which the element belongs.

$$\{L\}_{ij} = [C]_{ij} \{Q\}_j \quad (5-56)$$

This transformation is based on consideration of equilibrium of a free body which is a portion of the member excluding the i^{th} element. The fact that such a free body exists which is acted upon by only the $\{L\}_{ij}$ and $\{Q\}_j$ follows from the definition of a member as a portion of the structure with no redundant load paths. Figure 75 illustrates the typical procedure for deriving the "free-body" matrices.

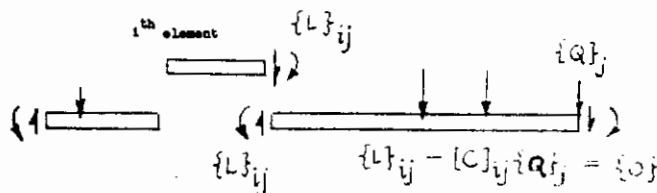

FIGURE 75 FREE BODY OF A PORTION OF THE MEMBER ACTED UPON BY THE REACTIONS IN AN ELEMENT

If Equation 5-56 is substituted into Equation 5-55, we obtain the following expression for the total strain energy in the j^{th} member.

$$U_j = \sum_i U_{ij} = \frac{1}{2} \{Q\}'_j \sum_i [C]'_{ij} [G]_{ij} [C]_{ij} \{Q\}_j \quad (5-57)$$

or

$$U_j = \frac{1}{2} \{Q\}'_j [G]_j \{Q\}_j \quad (5-58)$$

where

$$[G]_j = \sum_i [C]'_{ij} [G]_{ij} [C]_{ij} \quad (5-59)$$

In addition to this we have a relation between the $\{Q\}_j$ based on equilibrium of the whole member

$$[L]_j \{Q\}_j = \{0\} \quad (5-60)$$

The number of rows in $[L]_j$ will be no greater than six for any given member, corresponding to the six equilibrium relations for an arbitrary free body.

We finally introduce a "bookkeeping" transformation which relates the $\{Q\}_j$ to the aggregate of all the loads on all the members, $\{Q\}$. These loads

Contrails

are composed of internal loads and external loads. The external loads, $\{P\}$, are those generalized forces associated with generalized coordinates which are sufficient to describe the "external" configuration. For restrained systems, the Q 's must include the reactions from either determinant or redundant constraints. For unrestrained systems the Q 's must include the reactions at some arbitrary determinant constraint (i.e., at some arbitrary constraint just sufficient to prevent rigid body motion). The "bookkeeping" transformation is of the form

$$\{q\}_j = [c]_j \{Q\} \quad (5-61)$$

Substitution into Equations 5-58 and 5-60 yields

$$U = \frac{1}{2} \{Q\}^T [G] \{Q\} \quad (5-62)$$

$$[L] \{Q\} = \{0\} \quad (5-63)$$

where

$$[G] = \sum_j [c]_j^T [G]_j [c]_j \quad (5-64)$$

and

$$[L] = \begin{bmatrix} [L]_1 [c]_1 \\ [L]_2 [c]_2 \\ \vdots \\ [L]_j [c]_j \\ \vdots \end{bmatrix} \quad (5-65)$$

If we suppose that the $\{Q\}$ can be partitioned so that

$$\{Q\} = \begin{bmatrix} \{Q_1\} \\ \{Q_2\} \\ \{Q_3\} \end{bmatrix} \quad (5-66)$$

where

$\{Q_1\} = \{P\}$ = generalized forces associated with the "external" generalized coordinates

$\{Q_2\}$ = "redundant" loads

$\{Q_3\}$ = loads that can be determined from the equilibrium equations,

then the equilibrium equations can then be written as

$$[L_1] \{Q_1\} + [L_2] \{Q_2\} + [L_3] \{Q_3\} = \{0\} \quad (5-67)$$

Contrails

and the "determinant" loads may be solved for

$$\{Q_3\} = -[L_3]^T [L_1] \{Q_1\} - [L_3]^T [L_2] \{Q_2\}. \quad (5-68)$$

This may be rewritten as

$$\{Q\} = \begin{Bmatrix} \{Q_1\} \\ \{Q_2\} \\ \{Q_3\} \end{Bmatrix} = \begin{bmatrix} r_{11} & \\ 0 & \\ -[L_3]^T [L_1] & \end{bmatrix} \{Q_1\} + \begin{bmatrix} 0 & \\ r_{11} & \\ -[L_3]^T [L_2] & \end{bmatrix} \{Q_2\} \quad (5-69)$$

or as

$$\{Q\} = [C_1] \{Q_1\} + [C_2] \{Q_2\} \quad (5-70)$$

Substitution into the strain energy gives

$$U = \frac{1}{2} \begin{Bmatrix} \{Q_1\} \\ \{Q_2\} \end{Bmatrix} \begin{bmatrix} [G_{11}] & [G_{12}] \\ [G_{21}] & [G_{22}] \end{bmatrix} \begin{Bmatrix} \{Q_1\} \\ \{Q_2\} \end{Bmatrix} \quad (5-71)$$

where

$$[G_{11}] = [C_1]^T [G] [C_1] \quad (5-72)$$

$$[G_{12}] = [C_1]^T [G] [C_2] \quad (5-73)$$

$$[G_{21}] = [C_2]^T [G] [C_1] \quad (5-74)$$

$$[G_{22}] = [C_2]^T [G] [C_2] \quad (5-75)$$

Now, from Castigliano's theorem

$$\left\{ \frac{\partial U}{\partial Q_2} \right\} = \{Q_2\} \quad (5-76)$$

and Castigliano's second theorem essentially requires internal structural continuity by stating that $\{Q_2\} = \{0\}$.

In Equation 5-71

$$\left\{ \frac{\partial U}{\partial Q_2} \right\} = \{0\} \quad (5-77)$$

then leads to

$$[G_{21}] \{Q_1\} + [G_{22}] \{Q_2\} = \{0\} \quad (5-78)$$

from which

$$\{Q_2\} = -[G_{22}]^{-1} [G_{21}] \{Q_1\} \quad (5-79)$$

or

$$\begin{Bmatrix} \{Q_1\} \\ \{Q_2\} \end{Bmatrix} = \begin{bmatrix} r_{11} & \\ -[G_{22}]^{-1} [G_{21}] & \end{bmatrix} \{P\} \quad (5-80)$$

Contrails

Substitution into Equation 5-71 gives

$$U = \frac{1}{2} \{P\}' \begin{bmatrix} [1] & -[G_{12}][G_{22}]^{-1} \\ [G_{21}][G_{22}]^{-1} & [G_{11}] - [G_{12}][G_{22}]^{-1}[G_{21}] \end{bmatrix} \begin{Bmatrix} \{r_1\} \\ \{P\} \end{Bmatrix} \quad (5-81)$$

or

$$U = \frac{1}{2} \{P\}' [E] \{P\} \quad (5-82)$$

where the matrix of structural influence coefficients is given by

$$[E] = [G_{11}] - [G_{12}][G_{22}]^{-1}[G_{21}] \quad (5-83)$$

The stiffness matrix for the system is then

$$[K] = [E]^{-1} \quad (5-84)$$

if the system is restrained. If the structure is not restrained, then the arbitrary constraints imposed on $[E]$ may be uniquely removed by the following procedure.

For the unrestrained structure the loads, $\{P\}$, must satisfy equilibrium relations which can be expressed as

$$[L] \{P\} = \{0\} \quad (5-85)$$

Using these equations, some of the loads may be expressed in terms of the rest of the loads

$$\{P_2\} = -[L_2]^{-1}[L_1] \{P_1\} \quad (5-86)$$

or

$$\{P\} = \begin{Bmatrix} \{P_1\} \\ \{P_2\} \end{Bmatrix} = \begin{bmatrix} [1] & \\ & -[L_2]^{-1}[L_1] \end{bmatrix} \{P_1\} \quad (5-87)$$

or

$$\{P\} = [V] \{P_1\} \quad (5-88)$$

Now,

$$\{b\} = [E] \{P\} \quad (5-89)$$

and premultiplying by $[V]'$ and substituting Equation 5-88 gives

$$[V] \{b\} = [V]' [E] [V] \{P_1\} \quad (5-90)$$

or

$$\{P_1\} = ([V]' [E] [V])^{-1} [V] \{b\} \quad (5-91)$$

Contrails

Substitution into Equation 5-88 gives

$$\{P\} = [V]([V]'[E][V])^{-1}[V]'\{p\} \quad (5-92)$$

so that

$$[K] = [V]([V]'[E][V])^{-1}[V]' \quad (5-93)$$

for an unrestrained structure.

To relate the internal stress resultants to the applied loads, we note, first, that Equation 5-70 and Equation 5-80 can be combined to give

$$\{Q\} = [C]H\{P\} \quad (5-94)$$

where

$$\begin{aligned} [C] &= [c_1, c_2] \begin{bmatrix} r_1 \\ -[G_{22}]^{-1}[G_{21}] \end{bmatrix} \\ &= [c_1] - [c_2]([c_2]'[G][c_2])^{-1}[c_2]'[G][c_1] \end{aligned} \quad (5-95)$$

By successive substitution of Equations 5-61 and 5-94 into Equation 5-56, we have

$$\begin{aligned} \{L\}_{ij} &= [C]_{ij}\{Q\}_j \\ &= [C]_{ij}[C]_j\{P\} \\ &= [C]_{ij}[C]_j[C]\{P\} \end{aligned} \quad (5-96)$$

If $\{L\}$ is a matrix of pertinent stress resultants selected from the aggregate of the $\{L\}_{ij}$, then

$$\{L\} = [R]H\{P\} \quad (5-97)$$

where the rows of $[R]$ are selected from the rows of the matrix

$$[C]_{ij}[C]_j[C]$$

Figure 76 summarizes the operations for both the direct stiffness and the complementary energy methods of structural analysis.

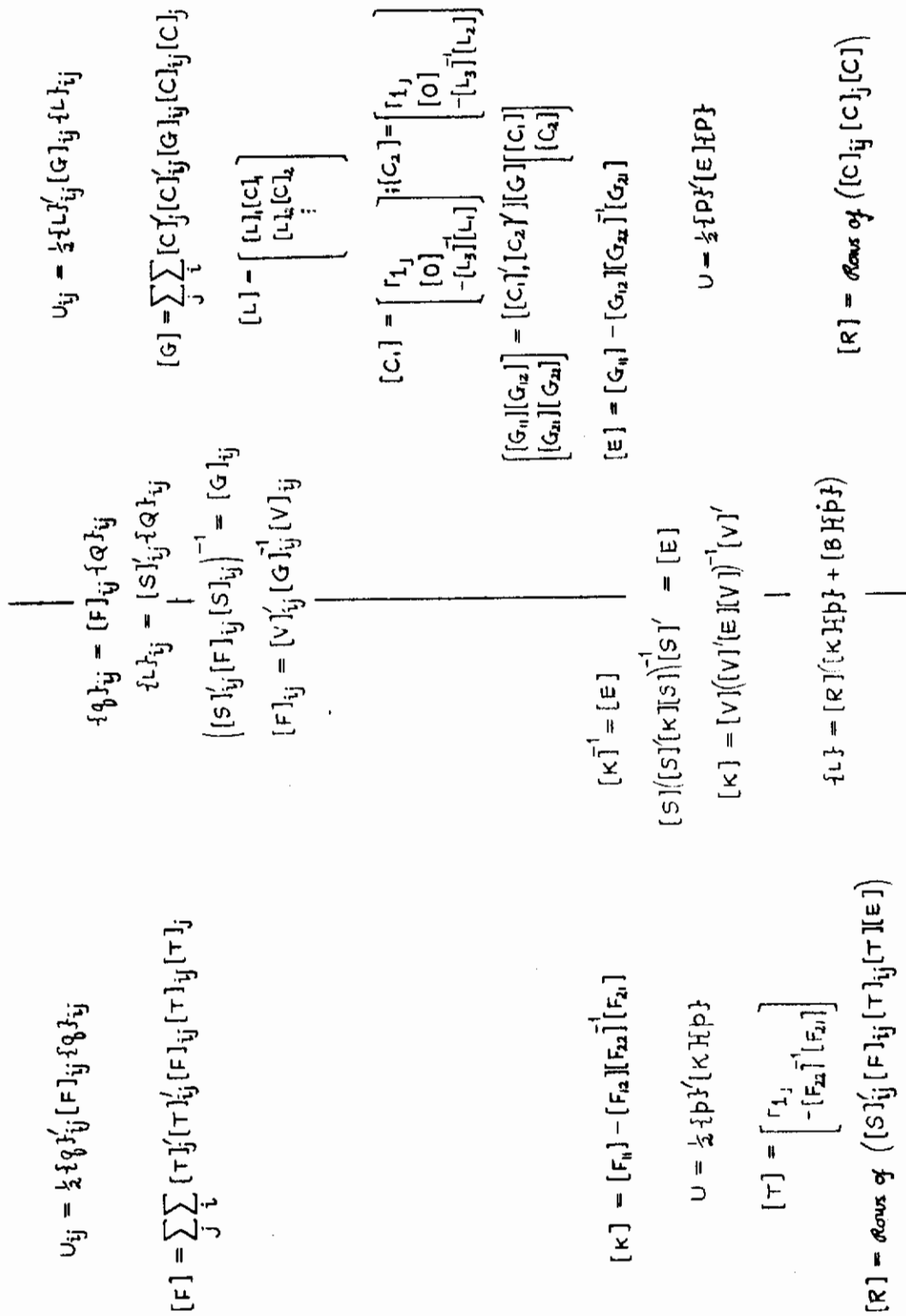

FIGURE 76 SUMMARY COMPARISON OF THE DIRECT STIFFNESS AND THE COMPLEMENTARY ENERGY METHODS OF STRUCTURAL ANALYSIS

5.1.1.3 Some General Considerations of Beam Theory

Almost all primary structural-load-carrying components in aerospace designs can be idealized as a beam. Figure 77 is intended to be a typical example.

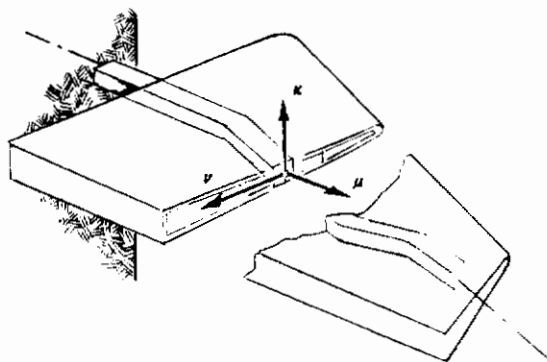

FIGURE 77 STRUCTURE IDEALIZED AS A BEAM

The beam model as an approximation affords a convenient structural analysis when time and/or detailed information is limited.

In order to be precise and to indicate the limits of applicability, we shall define a beam to be a structure symmetric about the x-y plane and having a median axis whose radius of curvature is at least greater than the width normal to the median axis¹. The section normal to the axis is assumed to be structurally connected as shown by Figure 78.

¹This assumption is made so that the median axis will have a well defined normal at each point.

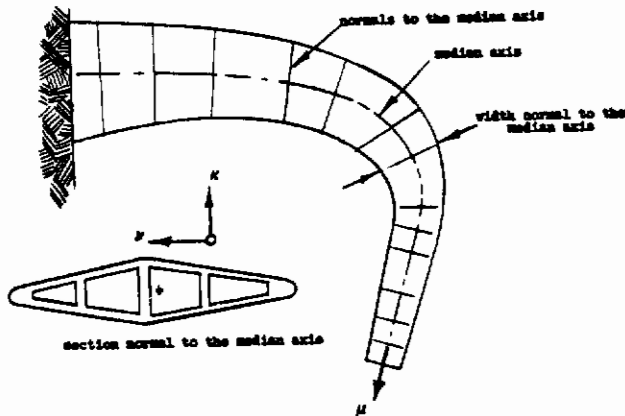

FIGURE 78 GEOMETRY OF A BEAM

We may introduce then a curvilinear coordinate system (μ, κ, ν) with μ measured along the arc of the median axis and κ, ν in the plane of a section normal to the axis.

The fundamental assumption of beam theory is that the only nonzero stresses on a section are:

$\sigma_{\mu\mu}$, the stress normal to the section

$\sigma_{\mu\kappa}$, vertical shear stress in the plane of the section

$\sigma_{\mu\nu}$, lateral shear stress in the plane of the section

The specific strain energy is then

$$u = \frac{1}{2} \left(\frac{\sigma_{\mu\mu}^2}{E} + \frac{\sigma_{\mu\kappa}^2 + \sigma_{\mu\nu}^2}{G} \right) \quad (5-98)$$

where E is Young's modulus and G is the shear modulus. If stress distributions satisfying the equations of linear elasticity are assumed, then they may be related to the total stress resultants for the whole section M, T , and V where

$$M(\mu) = \iint -\kappa \sigma_{\mu\mu} \, d\nu d\kappa \quad (5-99)$$

$$V(\mu) = \iint \sigma_{\mu\kappa} \, d\nu d\kappa \quad (5-100)$$

$$T(\mu) = \iint (\kappa \sigma_{\mu\nu} - \nu \sigma_{\mu\kappa}) d\nu d\kappa \quad (5-101)$$

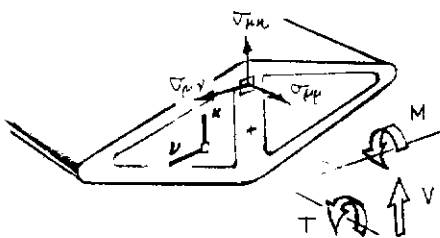

FIGURE 79 STRESS RESULTANTS ON A SECTION

As an introduction, we assume the distribution of stresses from elementary beam theory.

$$\sigma_{\mu\kappa} = -\kappa a \quad (5-102)$$

$$\sigma_{\mu\nu} = b - \nu c \quad (5-103)$$

$$\tau = \kappa c \quad (5-104)$$

By substitution into Equations 5-99, 5-100, and 5-101, we find that a , b , and c can be related to M , V , and T

$$M = \iint \kappa^2 d\nu d\kappa a \quad (5-105)$$

$$V = \iint d\nu d\kappa b - \iint \nu d\nu d\kappa c \quad (5-106)$$

$$T = \iint (\kappa^2 + \nu^2) d\nu d\kappa c - \iint \nu d\nu d\kappa b \quad (5-107)$$

If the origin of the κ, ν coordinates is placed at the "shear center," then

$$\iint \nu d\nu d\kappa = 0 \quad (5-108)$$

and we have

$$a = \frac{M}{\iint \kappa^2 d\nu d\kappa} = \frac{M}{I} \quad (5-109)$$

$$b = \frac{V}{\iint d\nu d\kappa} = \frac{V}{A} \quad (5-110)$$

$$c = \frac{T}{\iint (\kappa^2 + \nu^2) d\nu d\kappa} = \frac{T}{J} \quad (5-111)$$

where I is the second moment about the neutral surface, A is the section area, and J is the polar moment about the shear center. We then have

Contrails

$$\sigma_{\mu\mu} = -\kappa \frac{M}{I} \quad (5-112)$$

$$\sigma_{\mu\nu} = \frac{V}{A} - \nu \frac{T}{J} \quad (5-113)$$

$$\sigma_{\mu\gamma} = \kappa \frac{T}{J} \quad (5-114)$$

and substitution into the strain energy gives

$$u = \frac{1}{2} \left(\frac{\kappa^2 M^2}{EI^2} + \frac{V^2}{GA^2} - 2\nu \frac{VT}{GAJ} + \nu^2 \frac{T^2}{GJ^2} + \kappa^2 \frac{T^2}{GJ^2} \right) \quad (5-115)$$

The total strain energy in a length, $d\mu$, of the beam is then

$$\begin{aligned} dU &= \iint u \, d\gamma \, dk \, d\mu \\ &= \frac{1}{2} \left(\frac{M^2}{EI} + \frac{V^2}{GA} + \frac{T^2}{GJ} \right) d\mu \end{aligned} \quad (5-116)$$

and for the whole beam

$$U = \frac{1}{2} \int \left(\frac{M^2(\mu)}{EI(\mu)} + \frac{V^2(\mu)}{GA(\mu)} + \frac{T^2(\mu)}{GJ(\mu)} \right) d\mu \quad (5-117)$$

Surprisingly enough, the above equation is valid for more exact section stress distributions although in the case of stress distributions other than Equations 5-112, 5-113, and 5-114 the section properties $EI(\mu)$, $GA(\mu)$, and $GJ(\mu)$ cannot be interpreted as simple functions of the geometry of the section. The computation of the section properties and shear center locations for complicated sections is the difficult part of a structural analysis using beam theory.

Conventionally, the notation, EI , GA , GJ , is used even though these properties no longer have the interpretation they have in the more elementary beam theory.

5.1.1.3.1 The Computation of Beam Section Properties

5.1.1.3.1.1 Bending Rigidity

The preceding paragraph indicated that the normal stress and shear-stress are independent, so that $EI(\mu)$ can be determined separately from the analysis of shear stresses which gives $GA(\mu)$, $GJ(\mu)$, and the shear center location. Also, general experience indicates that for thin beams, the normal stresses are always approximated by Equation 5-112:

$$\sigma_{\mu\mu} = -\kappa \frac{M}{\iint k^2 \, d\gamma \, dk} \quad (5-118)$$

Then the bending strain energy is

$$\begin{aligned} dU &= \iint u \, d\gamma \, dk \, d\mu \\ &= \frac{1}{2} \iint \frac{\sigma_{\mu\mu}^2}{E} \, d\gamma \, dk \, d\mu \\ &= \frac{1}{2} M^2 \frac{\iint \frac{1}{E} \kappa^2 \, d\gamma \, dk}{\left(\iint \kappa^2 \, d\gamma \, dk \right)^2} d\mu \end{aligned} \quad (5-119)$$

So that in the case the section is made of different materials (that is, E varies with κ and ν), we have

$$\frac{1}{EI(\mu)} = \frac{\iint \frac{1}{E} \kappa^2 d\gamma d\kappa}{\left(\iint \kappa^2 d\gamma d\kappa\right)^2} \quad (5-120)$$

so that

$$EI(\mu) = \hat{E} \iint \kappa^2 d\gamma d\kappa = \hat{E} I \quad (5-121)$$

where the effective modulus is the following weighted average

$$\hat{E} = \frac{\iint \kappa^2 d\gamma d\kappa}{\iint \frac{1}{E} \kappa^2 d\gamma d\kappa} \quad (5-122)$$

In the case the section were made of only two materials, we would have

$$\hat{E} = \frac{I_1 + I_2}{\frac{1}{E_1} I_1 + \frac{1}{E_2} I_2} \quad (5-123)$$

with

$$I = I_1 + I_2 \quad (5-124)$$

5.1.1.3.1.2 Torsion Rigidity for Thin Wall Sections

A common beam section for light weight high strength structures is one composed of a number of thin-wall cells as in Figure 80.

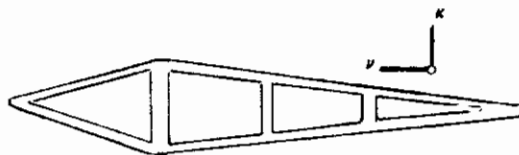

FIGURE 80 MULTI-CELL THIN WALL SECTION

The total torque on the section is (from Equation 5-101)

$$T = \iint (\kappa \sigma_{\mu\gamma} - \nu \sigma_{\mu\kappa}) d\gamma d\kappa \quad (5-125)$$

Using the thin wall assumption we may write this integral as a sum of integrals over the individual cells. For N cells

$$\iint () dV dk = \sum_{i=1}^N \oint () \tau ds \quad (5-126)$$

In this expression s is a curvilinear coordinate around the arc of the cell wall, and $\tau(s)$ is the thickness of the cell wall at a point, s . At webs adjacent to neighboring cells, τ is one-half of the web thickness, as in Figure 81.

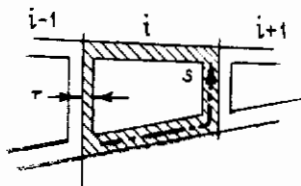

FIGURE 81 A SINGLE CELL

The torque, Q_i , contributed by the resultant of stresses over the i^{th} cell is given by

$$Q_i = \oint (\kappa \sigma_{\mu\nu} - \nu \sigma_{\mu\kappa}) \tau ds \quad (5-127)$$

Guided by the theory of elasticity, we make the following assumptions about the stress distribution:

- (1) The component of shear stress normal to the wall is zero
- (2) The component of shear stress tangent to the wall is inversely proportional to the section thickness

If $\vartheta(s)$ is the angle between the wall tangent and the ν -axis, the above assumptions can be expressed as

$$\sigma_{\mu\kappa} = \sigma \sin \vartheta \quad (5-128)$$

$$\sigma_{\mu\nu} = \sigma \cos \vartheta \quad (5-129)$$

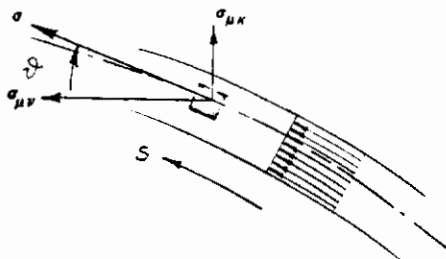

FIGURE 82 SHEARING STRESSES

The torque on the i^{th} cell is then

$$Q_i = \oint \sigma r (\kappa \cos \theta - r \sin \theta) ds \quad (5-130)$$

and it is easily shown that the enclosed area, A_i , of the i^{th} cell is

$$A_i = \frac{1}{2} \oint (\kappa r \cos \theta - r^2 \sin \theta) ds \quad (5-131)$$

The quantity

$$\frac{Q_i}{2A_i} = \frac{\oint \sigma r (\kappa \cos \theta - r \sin \theta) ds}{\oint (\kappa r \cos \theta - r^2 \sin \theta) ds} \quad (5-132)$$

is then the average value of σr around the i^{th} cell. We then assume

$$\sigma = \frac{1}{r} \left\{ \begin{array}{ll} \frac{Q_i}{2A_i} & \text{on upper and lower walls} \\ \frac{1}{2} \left(\frac{Q_i}{2A_i} - \frac{Q_{i+1}}{2A_{i+1}} \right) & \text{on the wall adjacent to } i + 1^{\text{st}} \text{ cell} \\ \frac{1}{2} \left(\frac{Q_i}{2A_i} - \frac{Q_{i-1}}{2A_{i-1}} \right) & \text{on the wall adjacent to } i - 1^{\text{st}} \text{ cell} \end{array} \right. \quad (5-133)$$

Contrails

We may write this as

$$\sigma(s) = \{f(s)\}' \{Q\}_i \quad (5-134)$$

where

$$\{Q\}_i = \begin{bmatrix} Q_{i-1} \\ Q_i \\ Q_{i+1} \end{bmatrix} \quad (5-135)$$

and

$$\{f(s)\}' = \begin{cases} \left\{ 0, \frac{k}{2A_i}, 0 \right\} & \text{s on bottom} \\ \left\{ 0, \frac{k}{4A_i}, -\frac{k}{4A_{i+1}} \right\} & \text{s on right side} \\ \left\{ 0, \frac{k}{2A_i}, 0 \right\} & \text{s on top} \\ \left\{ -\frac{k}{4A_{i+1}}, \frac{k}{4A_i}, 0 \right\} & \text{s on left side} \end{cases} \quad (5-136)$$

The specific internal strain energy (Equation 5-98) is

$$u = \frac{1}{2} \frac{\sigma_{\mu\nu}^2 + \sigma_{\nu\mu}^2}{G} \quad (5-137)$$

but, from Equations 5-128 and 5-129

$$\sigma_{\mu\kappa}^2 + \sigma_{\kappa\mu}^2 = \sigma^2 \quad (5-138)$$

Substitution of Equation 5-134 gives

$$u = \frac{1}{2} \frac{1}{G} \{Q\}_i' \{f(s)\} \{f(s)\}' \{Q\}_i \quad (5-139)$$

Contrails

The total strain energy up to the point μ is

$$U(\mu) = \int^{\mu} \int \int u \, dV \, d\mu \quad (5-140)$$

which gives

$$U(\mu) = \int^{\mu} \sum_{i=1}^N \oint u \, z \, ds \, d\mu \quad (5-141)$$

$$= \int^{\mu} \sum_{i=1}^N \frac{1}{2} \{Q\}_i' \oint \{f(s)\} \{f(s)\}' \frac{E}{G} \, ds \, \{Q\}_i \, d\mu$$

If we define

$$[G]_i = \oint \{f(s)\} \{f(s)\}' \frac{E}{G} \, ds \quad (5-142)$$

then

$$U(\mu) = \int^{\mu} \frac{1}{2} \sum_{i=1}^N \{Q\}_i' [G]_i \{Q\}_i \, d\mu \quad (5-143)$$

Now

$$\{Q\}_i = \begin{bmatrix} Q_{i-1} \\ Q_i \\ Q_{i+1} \end{bmatrix} = \begin{bmatrix} 0, 0, \dots, 1, 0, 0, \dots, 0 \\ 0, 0, \dots, 0, 1, 0, \dots, 0 \\ 0, 0, \dots, 0, 0, 1, \dots, 0 \end{bmatrix} \{Q\} \quad (5-144)$$

where

$$\{Q\} = \begin{bmatrix} Q_1 \\ Q_2 \\ \vdots \\ Q_N \end{bmatrix} \quad (5-145)$$

This defines the transformation

$$\{Q\}_i = [C]_i \{Q\} \quad (5-146)$$

Contrails

Substitution of this into the strain energy gives

$$U(\mu) = \int^{\mu} \frac{1}{2} \{Q\}^T [G] \{Q\} d\mu \quad (5-147)$$

where

$$[G] = \sum_{i=1}^N [C]_i^T [G]_i [C]_i \quad (5-148)$$

Now, the generalized coordinates, q_i , associated with the cell torques, Q_i , are rotations of the cells at section μ , and

$$q_i = \frac{\partial U}{\partial Q_i} \quad (5-149)$$

which gives

$$\{q\} = \int^{\mu} [G] \{Q\} d\mu \quad (5-150)$$

Compatibility requires that the cells all rotate together

$$q_1 = q_2 = \dots = q_N = \theta(\mu) \quad (5-151)$$

so that

$$\int^{\mu} [G] \{Q\} d\mu = \{1\} \theta(\mu) \quad (5-152)$$

or

$$[G] \{Q\} = \{1\} \frac{d\theta}{d\mu} \quad (5-153)$$

Solving for the Q_i 's, we obtain

$$\{Q\} = [G]^{-1} \{1\} \frac{d\theta}{d\mu} \quad (5-154)$$

Now, the total torque is

$$T = \sum_{i=1}^N Q_i = \{I\}' \{Q\} \quad (5-155)$$

or

$$T = \{I\}' [G]^{-1} \{I\} \frac{d\theta}{d\mu} \quad (5-156)$$

Substituting Equation 5-154 into Equation 5-147, we obtain

$$U = \frac{1}{2} \int \{I\}' [G]^{-1} \{I\} \left(\frac{d\theta}{d\mu}\right)^2 d\mu \quad (5-157)$$

but, from Equation 5-156,

$$\frac{d\theta}{d\mu} = \frac{T}{\{I\}' [G]^{-1} \{I\}} \quad (5-158)$$

so that

$$U = \frac{1}{2} \int \frac{T^2}{\{I\}' [G]^{-1} \{I\}} d\mu \quad (5-159)$$

By comparison with Equation 5-117, we must conclude that the effective torsional rigidity is

$$\boxed{GJ(a) = \{I\}' [G]^{-1} \{I\}} \quad (5-160)$$

5.1.1.3.1.3 Shear Rigidity for Thin-Wall Cylinders

For a cylindrical, thin-wall section as in Figure 83, we can assume a stress distribution consistent with the theory of elasticity and obtain an expression for the shear rigidity.

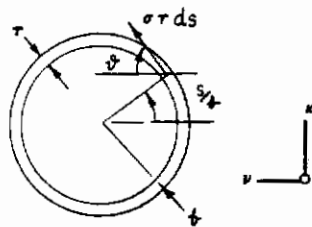

FIGURE 83 SHEAR STRESS ON A THIN-WALL CYLINDER

If we assume

$$\tau(s) = a \cos \frac{s}{t} \quad (5-161)$$

then we have

$$\begin{aligned} \sigma_{\mu\kappa} &= \tau \sin \vartheta \\ &= a \cos \frac{s}{t} \sin \vartheta \end{aligned} \quad (5-162)$$

For a circular cylinder

$$\vartheta = \frac{\pi}{2} - \frac{s}{t} \quad (5-163)$$

so that

$$\begin{aligned} \sigma_{\mu\kappa} &= a \cos \frac{s}{t} \sin \left(\frac{\pi}{2} - \frac{s}{t} \right) \\ &= a \cos^2 \frac{s}{t} \end{aligned} \quad (5-164)$$

and

$$\begin{aligned} V &= \iint \sigma_{\mu\kappa} \, a \, r \, ds \\ &= \oint a \cos^2 \frac{s}{t} \, \tau \, ds \\ &= a \tau \int_0^{2\pi} \cos^2 \frac{s}{t} \, d\left(\frac{s}{t}\right) \\ &= a \tau t \pi \end{aligned} \quad (5-165)$$

Contrails

so that

$$a = \frac{V}{\tau b \pi} \quad (5-166)$$

and

$$\sigma = \frac{V}{\tau b \pi} \cos \frac{s}{b} \quad (5-167)$$

and the strain energy is

$$\begin{aligned} u &= \frac{1}{2} \frac{\sigma^2}{G} \\ &= \frac{1}{2} \frac{\cos^2 \frac{s}{b}}{G \tau^2 b^2 \pi^2} V^2 \end{aligned} \quad (5-168)$$

$$\begin{aligned} U &= \iiint u \, d\mu \, d\kappa \, d\mu \\ &= \frac{1}{2} \int \oint \frac{\cos^2 \frac{s}{b} \tau}{G \tau^2 b^2 \pi^2} \, ds \, V^2 \, d\mu \\ &= \frac{1}{2} \int \frac{\tau b}{G \tau^2 b^2 \pi^2} \int_0^{2\pi} \cos^2 \frac{s}{b} \, d\left(\frac{s}{b}\right) V^2 \, d\mu \\ &= \frac{1}{2} \int \frac{V^2}{G \tau b \pi} \, d\mu \end{aligned} \quad (5-169)$$

By comparison with Equation 5-117, we conclude that

$$GA(\mu) = G \tau b \pi \quad (5-170)$$

The result here is interesting in view of the fact that the area of the section is $2G\tau b\pi$, and hence the effective "GA" is one-half of G times A.

5.1.1.3.2 Influence Coefficients for a Beam by the Complementary Energy Method

The general expression for the strain energy of a beam from results of the previous section is:

$$U = \frac{1}{2} \int \left(\frac{M^2}{EI} + \frac{V^2}{GA} + \frac{T^2}{GJ} \right) dx \quad (5-171)$$

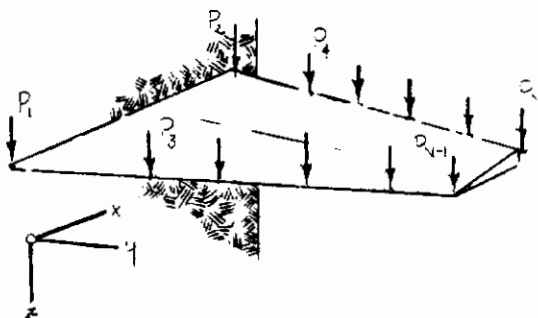

FIGURE 84 LOADED BEAM

If the beam is loaded at a number of points \$(x_i, y_i)\$ by vertical loads, \$P_i\$, then an "element" of the beam can be considered to be a portion of the beam between two successive slices normal to the median axis such that loads act only on the boundary.

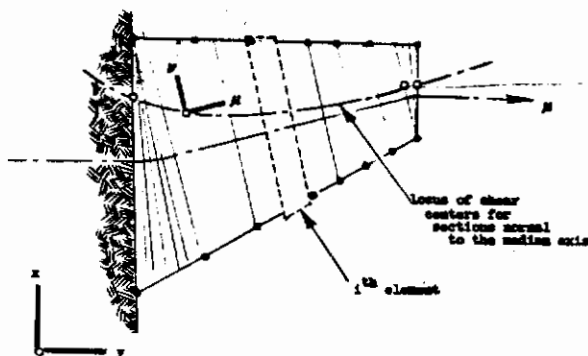

FIGURE 85 GEOMETRY OF THE BEAM AND SUBDIVISION INTO ELEMENTS

If we apply the general complementary energy method discussed in Paragraph 5.1.1.2, we have first to consider the strain energy in the i^{th} element

$$U_i = \frac{1}{2} \int_{\mu_{i-1}}^{\mu_i} \left(\frac{M^2(\mu)}{EI(\mu)} + \frac{V^2(\mu)}{GA(\mu)} + \frac{T^2(\mu)}{GJ(\mu)} \right) d\mu \quad (5-172)$$

and we introduce

$V_i = V(\mu_i^-)$ = the shear just to the left of $\mu = \mu_i$

$M_i = M(\mu_i^-)$ = the moment just to the left of $\mu = \mu_i$

$T_i = T(\mu_i^-)$ = the torque just to the left of $\mu = \mu_i$

If the element is not loaded except at the ends, then Figure 86 shows the loads acting on the i^{th} element.

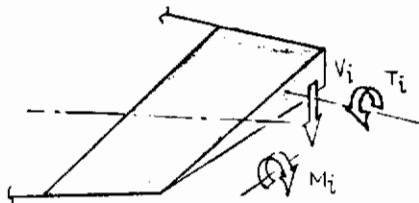

FIGURE 86 LOADS AT THE END OF AN ELEMENT

The shear, moment, and torque on the interior of the i^{th} element are related by equilibrium to the shear, moment, and torque at the right end.

$$V(\mu) = V_i \quad (5-173)$$

$$M(\mu) = M_i + (\mu_i - \mu)V_i \quad (5-174)$$

$$T(\mu) = T_i + (S(\mu) - S_i)V_i \quad (5-175)$$

These relations are evident from Figure 87.

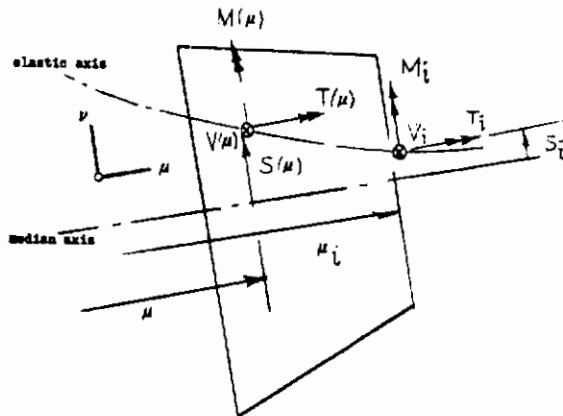

FIGURE 87 FREE BODY OF AN ELEMENT

We may write Equations 5-173, 5-174, and 5-175 as

$$V(\mu) = \{1 \ 0 \ 0\} \{L\}_i \quad (5-176)$$

$$M(\mu) = \{\mu_i - \mu, 1 \ 0\} \{L\}_i \quad (5-177)$$

$$T(\mu) = \{s(\mu) - s_i, 0, 1\} \{L\}_i \quad (5-178)$$

where

$$\{L\}_i = \begin{bmatrix} V_i \\ M_i \\ T_i \end{bmatrix} \quad (5-179)$$

Contrails

Substitution of these relations into Equation 5-172 gives

$$u_i = \frac{1}{2} \{L\}_i^T [G]_i \{L\}_i \quad (5-180)$$

where

$$[G]_i = \int_{\mu_{i-1}}^{\mu_i} \left(\frac{1}{GA(\mu)} \begin{bmatrix} 1 & 0 & 0 \\ 0 & 0 & 0 \\ 0 & 0 & 0 \end{bmatrix} + \frac{1}{EI(\mu)} \begin{bmatrix} (\mu_i - \mu)^2 & (\mu_i - \mu) & 0 \\ (\mu_i - \mu) & 1 & 0 \\ 0 & 0 & 0 \end{bmatrix} + \frac{1}{GJ(\mu)} \begin{bmatrix} (s(\mu) - s_i)^2 & 0 & s(\mu) - s_i \\ 0 & 0 & 0 \\ s(\mu) - s_i & 0 & 1 \end{bmatrix} \right) d\mu \quad (5-181)$$

This can be expressed more conveniently in terms of a non-dimensional integration variable,

$$s = \frac{\mu_i - \mu}{\mu_i - \mu_{i-1}}, \quad \Delta\mu_i = \mu_i - \mu_{i-1} \quad (5-182)$$

so that

$$[G]_i = \int_0^1 \begin{bmatrix} \frac{1}{GA} + \frac{s^2 \Delta\mu_i^2}{EI} + \frac{(s-s_i)^2}{GJ}, & \frac{s \Delta\mu_i}{EI}, & \frac{(s-s_i)}{GJ} \\ \frac{s \Delta\mu_i}{EI}, & \frac{1}{EI}, & 0 \\ \frac{(s-s_i)}{GJ}, & 0, & \frac{1}{GJ} \end{bmatrix} \Delta\mu_i ds \quad (5-183)$$

In order to relate the element stress resultants, $\{L\}_i$, to the applied loads, we consider the equilibrium of a free body of the portion of the beam to the right of the section $\mu = \mu_i$

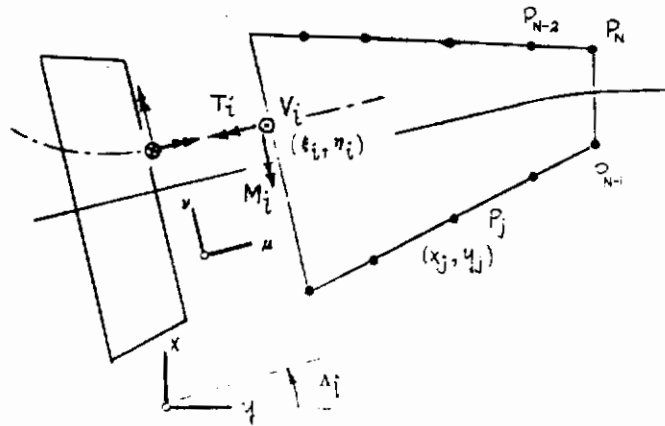

FIGURE 88 FREE BODY OF STRUCTURE ADJACENT TO ELEMENT

If ξ_i and η_i are the x and y coordinates, respectively, of the shear center at the i^{th} section, then

$$V_i = 0 \cdot P_1 + 0 \cdot P_2 + \dots + P_j + P_{j+1} + \dots + P_{N-1} + P_N \quad (5-184)$$

$$M_i = -\cos \Delta_i (0 \cdot P_1 + 0 \cdot P_2 + \dots + (y_j - \eta_i) P_j + \dots + (y_{N-1} - \eta_i) P_{N-1}) \\ - \sin \Delta_i (0 \cdot P_1 + 0 \cdot P_2 + \dots + (x_j - \xi_i) P_j + \dots + (x_{N-1} - \xi_i) P_{N-1})$$

$$T_i = -\sin \Delta_i (0 \cdot P_1 + 0 \cdot P_2 + \dots + (y_j - \eta_i) P_j + \dots + (y_{N-1} - \eta_i) P_{N-1}) \\ + \cos \Delta_i (0 \cdot P_1 + 0 \cdot P_2 + \dots + (x_j - \xi_i) P_j + \dots + (x_{N-1} - \xi_i) P_{N-1})$$

These relations can be written more concisely as

$$\{L\}_i = \begin{bmatrix} V_i \\ M_i \\ T_i \end{bmatrix} = [C]_i \{P\} \quad (5-185)$$

Contraails

where

$$\{D\}_i = \begin{bmatrix} p_i \\ f_i \\ \vdots \\ r_i \end{bmatrix} \quad (5-186)$$

and

$$[C]_i = \begin{bmatrix} 0, c, \dots & & & \\ c, c, \dots & -\cos \Lambda_i (y_j - \gamma_i) - \sin \Lambda_i (x_j - \delta_i) & \dots & \cos \Lambda_i (y_n - \gamma_i) \\ 0, c, \dots & -\sin \Lambda_i (y_j - \gamma_i) + \cos \Lambda_i (x_j - \delta_i) & \dots & \end{bmatrix} \quad (5-187)$$

Substitution of Equation 5-185 into Equation 5-180 gives

$$u_i = \frac{1}{2} \{P\}'_i [C]_i [G]_i [C]_i \{P\}_i \quad (5-188)$$

and since

$$U = \sum_i u_i \quad (5-189)$$

we have

$$U = \frac{1}{2} \{P\}' \sum_i [C]_i [G]_i [C]_i \{P\} \quad (5-190)$$

or

$$U = \frac{1}{2} \{P\}' [E] \{P\} \quad (5-191)$$

where

$$[E] = \sum_i [C]_i [G]_i [C]_i \quad (5-192)$$

which is a set of influence coefficients for the beam cantilevered at $\mu = 0$.

5.1.2 Procedures for Calculating Inertia Matrices for Components of a Complex Structure

In this section we discuss some of the specific procedures for deriving inertia matrices for parts of a structure in terms of generalized coordinates defining the configuration of those parts. Inertia matrices for a whole system can then be formed by appropriate geometric transformations relating the generalized coordinates of the component to generalized coordinates for the whole system. The fundamental starting point, for each of the discussions below, is the form of the kinetic energy given in Equation 2-42, Paragraph 2.1.2.1.

$$T = \frac{1}{2} \int \frac{\partial \mathbf{r}}{\partial \mathbf{e}} \cdot \frac{\partial \mathbf{r}}{\partial \mathbf{e}} \rho dV \quad (5-193)$$

For small motions, as discussed in Paragraph 2.3.1 (Equation 2-357), we have

$$\begin{aligned} \mathbf{r}(x, y, z, t) = & (x + p_x(x, y, z, t))\mathbf{I} \\ & + (y + p_y(x, y, z, t))\mathbf{J} \\ & + (z + p_z(x, y, z, t))\mathbf{K} \end{aligned} \quad (5-194)$$

and Equation 5-193 reduces to

$$T = \frac{1}{2} \int \left(\left(\frac{\partial p_x}{\partial \mathbf{e}} \right)^2 + \left(\frac{\partial p_y}{\partial \mathbf{e}} \right)^2 + \left(\frac{\partial p_z}{\partial \mathbf{e}} \right)^2 \right) \rho dV \quad (5-195)$$

where

$\rho dV = \rho(x, y, z) dx dy dz$	= mass of the x-y-z particle
$p_x(x, y, z, t)$	= displacement of the x-y-z particle in the x-direction
$p_y(x, y, z, t)$	= displacement of the x-y-z particle in the y-direction
$p_z(x, y, z, t)$	= displacement of the x-y-z particle in the z-direction

5.1.2.1 Rigid Components

For a part of the structure which can be considered to be rigid, we can introduce six generalized coordinates which will define the configuration of the component. If we let these six generalized coordinates be the displacements and rotations at some point of the body, and if we label this point "O," then

(5-196)

$$\{b\} = \begin{bmatrix} b_1 \\ b_2 \\ b_3 \\ b_4 \\ b_5 \\ b_6 \end{bmatrix}$$

These displacements are defined in Figure 89.

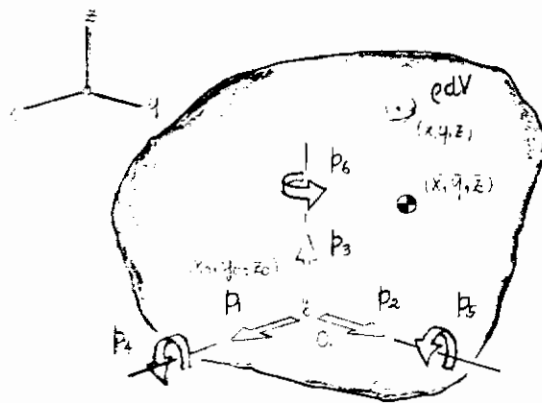

FIGURE 89 GENERALIZED COORDINATES FOR A RIGID BODY

The displacements of each of the particles can then be related to these coordinates.

$$p_x(x, y, z, t) = b_1(t) - (y - y_0) b_5(t) + (z - z_0) b_6(t) \quad (5-197)$$

Contrails

$$p_4(x, y, z, t) = p_2(t) + (x-x_0)p_6(t) - (z-z_0)p_4(t) \quad (5-198)$$

$$p_2(x, y, z, t) = p_3(t) + (y-y_0)p_4(t) - (x-x_0)p_5(t) \quad (5-199)$$

The velocities of the particles can be written as

$$\frac{\partial p_x}{\partial t} = \{1, 0, 0, 0, z-z_0, -(y-y_0)\} \begin{bmatrix} p_1 \\ p_2 \\ p_3 \\ p_4 \\ p_5 \\ p_6 \end{bmatrix} = \{h_x\} \{p\} \quad (5-200)$$

$$\frac{\partial p_y}{\partial t} = \{0, 1, 0, -(z-z_0), 0, (x-x_0)\} \begin{bmatrix} p_1 \\ p_2 \\ p_3 \\ p_4 \\ p_5 \\ p_6 \end{bmatrix} = \{h_y\} \{p\} \quad (5-201)$$

$$\frac{\partial p_z}{\partial t} = \{0, 0, 1, (y-y_0), -(x-x_0), 0\} \begin{bmatrix} p_1 \\ p_2 \\ p_3 \\ p_4 \\ p_5 \\ p_6 \end{bmatrix} = \{h_z\} \{p\} \quad (5-202)$$

Contrails

For simplicity we assume that the point O is the origin so that $x_0 = y_0 = z_0 = 0$. Squaring these expressions and substituting into Equation 5-195, we have

$$T = \frac{1}{2} \dot{\mathbf{p}}^T [A] \dot{\mathbf{p}} \quad (5-203)$$

where

$$[A] = \int (\dot{h}_x^2 + \dot{h}_y^2 + \dot{h}_z^2) \rho dV$$

$$= \int \begin{bmatrix} 1 & 0 & 0 & z & -y & 0 \\ 0 & 1 & 0 & -z & 0 & x \\ 0 & 0 & 1 & y & -x & 0 \\ 0 & -z & y & y^2+z^2 & -xy & -xz \\ x & 0 & -x^2 & -xy & x^2+z^2 & -yz \\ -y & x & 0 & -xz & -yz & x^2+y^2 \end{bmatrix} \rho dx dy dz \quad (5-204)$$

The terms in the above matrix can be recognized as common terms describing the inertia characteristics of a rigid body. In fact, we have

$$[A] = \begin{bmatrix} M & 0 & 0 & 0 & M\bar{z} & -M\bar{y} \\ 0 & M & 0 & -M\bar{z} & 0 & M\bar{x} \\ 0 & 0 & M & M\bar{y} & -M\bar{x} & 0 \\ 0 & -M\bar{z} & M\bar{y} & I_{xx} & -I_{xy} & -I_{xz} \\ +M\bar{z} & 0 & -M\bar{x} & -I_{xy} & I_{yy} & -I_{yz} \\ -M\bar{y} & M\bar{x} & 0 & -I_{xz} & -I_{yz} & I_{zz} \end{bmatrix} \quad (5-205)$$

Contrails

where

$$M = \int \rho dV = \text{total mass of the body} \quad (5-206)$$

$$\bar{x}M = \int \rho x dV \quad \bar{x} = \text{x-coordinate of center-of-mass} \quad (5-207)$$

$$\bar{y}M = \int \rho y dV \quad \bar{y} = \text{y-coordinate of center-of-mass} \quad (5-208)$$

$$\bar{z}M = \int \rho z dV \quad \bar{z} = \text{z-coordinate of center-of-mass} \quad (5-209)$$

$$I_{xx} = \int (y^2 + z^2) \rho dV \quad (5-210)$$

$$I_{yy} = \int (x^2 + z^2) \rho dV \quad \left. \begin{array}{l} \\ \\ \end{array} \right\} \text{moments of inertia} \quad (5-211)$$

$$I_{zz} = \int (x^2 + y^2) \rho dV \quad (5-212)$$

$$I_{xy} = \int xy \rho dV \quad (5-213)$$

$$I_{xz} = \int xz \rho dV \quad \left. \begin{array}{l} \\ \\ \end{array} \right\} \text{products of inertia} \quad (5-214)$$

$$I_{yz} = \int yz \rho dV \quad (5-215)$$

5.1.2.2 One-Dimensional Flexible Components

For a one-dimensional body moving in a plane, the configuration can be defined by generalized coordinates which are displacements at a number of collocation points.

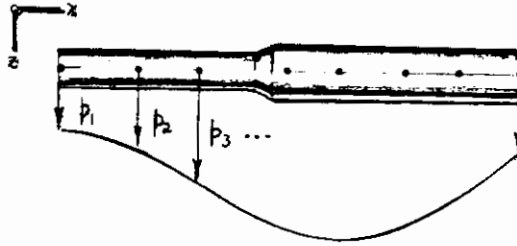

FIGURE 90 GENERALIZED COORDINATES FOR A ONE-DIMENSIONAL COMPONENT

In the general expression (Equation 5-195) for the kinetic energy, we have, for a one-dimensional body,

$$p_x(x, y, z, t) = p_y(x, y, z, t) = 0 \quad (5-216)$$

and p_z is not a function of y or z , so that

$$\begin{aligned} T &= \frac{1}{2} \int \left(\left(\frac{\partial p_z}{\partial t} \right)^2 + \left(\frac{\partial p_x}{\partial t} \right)^2 + \left(\frac{\partial p_y}{\partial t} \right)^2 \right) \rho dV \\ &= \frac{1}{2} \int \left(\frac{\partial p_z}{\partial t} \right)^2 \iiint \rho dy dz dx \\ &= \frac{1}{2} \int m(x) \left(\frac{\partial p_z}{\partial t} \right)^2 dx \end{aligned} \quad (5-217)$$

Contrails

where $m(x) = \iint \rho \, dy \, dz =$ mass per unit of length. We can relate the displacement of the particles, p_z , to the generalized coordinates, p_i , in a number of ways. A very simple way employs trapezoidal interpolation:

$$\begin{aligned}
 p_z(x,t) &= p_{i-1} + \frac{x-x_{i-1}}{x_i-x_{i-1}} (p_i - p_{i-1}) \\
 &= \left\{ 1 - \frac{x-x_{i-1}}{x_i-x_{i-1}}, \frac{x-x_{i-1}}{x_i-x_{i-1}} \right\} \begin{bmatrix} p_{i-1} \\ p_i \end{bmatrix}
 \end{aligned}
 \tag{5-218}$$

for $x_{i-1} \leq x \leq x_i$

(Note, $x_0 = 0$, $x_N = L$)

We can write

$$\int (\quad) dx = \sum_{i=1}^N \int_{x_{i-1}}^{x_i} (\quad) dx.
 \tag{5-219}$$

in Equation 5-217 and use Equation 5-218 to obtain

$$\begin{aligned}
 T &= \frac{1}{2} \sum_{i=1}^N \{ \dot{p}_{i-1} \quad \dot{p}_i \} \int_{x_{i-1}}^{x_i} \begin{bmatrix} \left(1 - \frac{x-x_{i-1}}{x_i-x_{i-1}}\right)^2 & \left(1 - \frac{x-x_{i-1}}{x_i-x_{i-1}}\right) \left(\frac{x-x_{i-1}}{x_i-x_{i-1}}\right) \\ \left(1 - \frac{x-x_{i-1}}{x_i-x_{i-1}}\right) \left(\frac{x-x_{i-1}}{x_i-x_{i-1}}\right) & \left(\frac{x-x_{i-1}}{x_i-x_{i-1}}\right)^2 \end{bmatrix} m(x) dx \begin{bmatrix} \dot{p}_{i-1} \\ \dot{p}_i \end{bmatrix} \\
 &= \frac{1}{2} \sum_{i=1}^N \{ \dot{p}_{i-1} \quad \dot{p}_i \} [A]_i \begin{bmatrix} \dot{p}_{i-1} \\ \dot{p}_i \end{bmatrix}
 \end{aligned}
 \tag{5-220}$$

where

$$[A]_i = \int_{x_{i-1}}^{x_i} \begin{bmatrix} \left(1 - \frac{x-x_{i-1}}{x_i-x_{i-1}}\right)^2 & \left(1 - \frac{x-x_{i-1}}{x_i-x_{i-1}}\right) \left(\frac{x-x_{i-1}}{x_i-x_{i-1}}\right) \\ \left(1 - \frac{x-x_{i-1}}{x_i-x_{i-1}}\right) \left(\frac{x-x_{i-1}}{x_i-x_{i-1}}\right) & \left(\frac{x-x_{i-1}}{x_i-x_{i-1}}\right)^2 \end{bmatrix} m(x) dx
 \tag{5-221}$$

Contrails

For practical computation this expression can be considerably simplified. If we change the variable of integration to

$$\xi = \frac{\lambda - x_{i-1}}{x_i - x_{i-1}} \quad (5-222)$$

and introduce the length of the interval,

$$l_i = x_i - x_{i-1} \quad (5-223)$$

then

$$[A]_i = \int_0^1 \begin{bmatrix} (1-\xi)^2 & (1-\xi)\xi \\ \xi(1-\xi) & \xi^2 \end{bmatrix} m(x) l_i d\xi \quad (5-224)$$

In the special case that $m(x)$ is constant over the interval, this can be integrated explicitly to give

$$[A]_i = \begin{bmatrix} \frac{ml_i}{3} & \frac{ml_i}{6} \\ \frac{ml_i}{6} & \frac{ml_i}{3} \end{bmatrix} = \begin{bmatrix} \frac{M_i}{3} & \frac{M_i}{6} \\ \frac{M_i}{6} & \frac{M_i}{3} \end{bmatrix} \quad (5-225)$$

where M_i is the total mass of the body between x_{i-1} and x_i .

If we write Equation 5-218 as

$$\ddot{x}(x, t) = \{1 \ \xi\} [D]_i \begin{bmatrix} p_{i-1} \\ p_i \end{bmatrix} \quad (5-226)$$

for $x_{i-1} \leq x \leq x_i$

where

$$[D]_i = \begin{bmatrix} 1 & 0 \\ -1 & 1 \end{bmatrix} \quad (5-227)$$

for each i

Contrails

then Equation 5-224 can be further simplified to

$$[A]_i = [J]_i' \int_0^1 \begin{bmatrix} 1 & \xi \\ \xi & \xi^2 \end{bmatrix} m(x) l_i d\xi [J]_i \quad (5-228)$$

This can be evaluated by numerical integration, or it can be noted that

$$\int_0^1 m(x) d\xi = \frac{M_i}{l_i} \quad (5-229)$$

$$\int_0^1 \xi m(x) d\xi = \frac{\bar{x}_i - x_{i-1}}{l_i} \frac{M_i}{l_i} \quad (5-230)$$

$$\int_0^1 \xi^2 m(x) d\xi = \frac{1}{l_i^2} \frac{I_i}{l_i} \quad (5-231)$$

where

- M_i is the total mass of the i^{th} segment,
- \bar{x}_i is the x-coordinate of the center of mass of the i^{th} segment, and
- I_i is the total moment of inertia of the i^{th} segment about the left end, $x = x_{i-1}$.

If we finally introduce the transformation, $[T]_i$, such that

$$\begin{bmatrix} a_i \\ b_i \end{bmatrix} = [T]_i \{p\} \quad (5-232)$$

where

$$\{p\} = \begin{bmatrix} p_1 \\ p_2 \\ p_3 \\ \vdots \\ p_{n+1} \end{bmatrix} \quad (5-233)$$

then

$$\begin{aligned}
 T &= \frac{1}{2} \sum_{i=1}^M \{ \dot{p}_{i-1} \quad \dot{p}_i \} [A]_i \begin{Bmatrix} \dot{p}_{i-1} \\ \dot{p}_i \end{Bmatrix} & (5-234) \\
 &= \frac{1}{2} \{ \dot{p} \}' \sum_{i=1}^M [T]'_i [A]_i [T]_i \{ \dot{p} \}
 \end{aligned}$$

or

$$T = \frac{1}{2} \{ \dot{p} \}' [A] \{ \dot{p} \} \quad (5-235)$$

where

$$[A] = \sum_{i=1}^M [T]'_i [A]_i [T]_i \quad (5-236)$$

5.1.2.3 Two-Dimensional Flexible Components

For a plane two-dimensional body moving normal to its own plane, the configuration can again be defined by generalized coordinates which are displacements at discrete points.

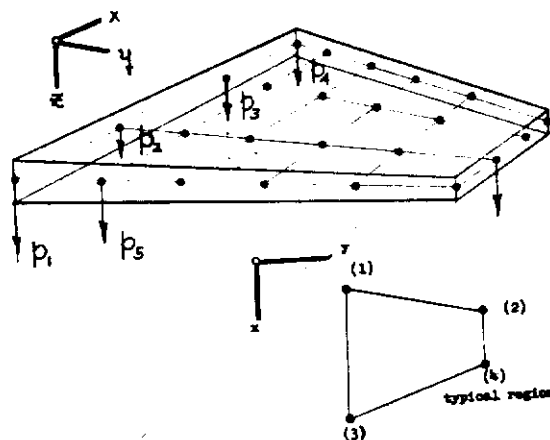

FIGURE 91 GENERALIZED COORDINATES FOR A TWO-DIMENSIONAL COMPONENT

Contrails

In the general expression (Equation 5-195) for the kinetic energy, we have, for a two-dimensional body

$$p_x(x, y, z, t) = p_y(x, y, z, t) = 0 \quad (5-237)$$

and p_z is not a function of z , so that

$$\begin{aligned} \tau &= \frac{1}{2} \int \left(\rho \left(\frac{\partial p_x}{\partial t} \right)^2 + \rho \left(\frac{\partial p_y}{\partial t} \right)^2 + \rho \left(\frac{\partial p_z}{\partial t} \right)^2 \right) dV \\ &= \frac{1}{2} \iint \left(\frac{\partial p_z}{\partial t} \right)^2 \int \rho dz dx dy \\ &= \frac{1}{2} \iint m(x, y) \left(\frac{\partial p_z}{\partial t} \right)^2 dx dy \end{aligned} \quad (5-238)$$

where $m(x, y) = \int \rho dz =$ mass per unit of area.

One of the simplest assumptions that can be made for relating p_z to the p_i in two dimensions is the "bilinear" interpolation assumption. In the region between four collocation points, we assume

$$p_z(x, y, t) = a + bx + cy + dxy \quad (5-239)$$

where a , b , c , and d are determined so that, at the i^{th} collocation point,

$$p_z(x_i, y_i, t) = p_i \quad (5-240)$$

In order to be systematic, we define, for the i^{th} region,

$$\{p\}_i = \begin{bmatrix} p_z(x_i^{(1)}, y_i^{(1)}, t) \\ p_z(x_i^{(2)}, y_i^{(2)}, t) \\ p_z(x_i^{(3)}, y_i^{(3)}, t) \\ p_z(x_i^{(4)}, y_i^{(4)}, t) \end{bmatrix} \quad (5-241)$$

Contrails

These displacements are related to the generalized coordinates by a transformation of zero's and one's (a "bookkeeping" matrix).

$$\{p\}_i = [T]_i \{b\} \quad (5-242)$$

Then, from Equation 5-239,

$$\begin{aligned} \{p\}_i &= \begin{bmatrix} a + b x_i^{(1)} + c y_i^{(1)} + d x_i^{(1)} y_i^{(1)} \\ a + b x_i^{(2)} + c y_i^{(2)} + d x_i^{(2)} y_i^{(2)} \\ a + b x_i^{(3)} + c y_i^{(3)} + d x_i^{(3)} y_i^{(3)} \\ a + b x_i^{(4)} + c y_i^{(4)} + d x_i^{(4)} y_i^{(4)} \end{bmatrix} \\ &= \begin{bmatrix} 1 & x_i^{(1)} & y_i^{(1)} & x_i^{(1)} y_i^{(1)} \\ 1 & x_i^{(2)} & y_i^{(2)} & x_i^{(2)} y_i^{(2)} \\ 1 & x_i^{(3)} & y_i^{(3)} & x_i^{(3)} y_i^{(3)} \\ 1 & x_i^{(4)} & y_i^{(4)} & x_i^{(4)} y_i^{(4)} \end{bmatrix} \begin{bmatrix} a \\ b \\ c \\ d \end{bmatrix} \end{aligned} \quad (5-243)$$

Solving for a, b, c, and d, we have

$$\begin{aligned} \begin{bmatrix} a \\ b \\ c \\ d \end{bmatrix} &= \begin{bmatrix} 1 & x_i^{(1)} & y_i^{(1)} & x_i^{(1)} y_i^{(1)} \\ 1 & x_i^{(2)} & y_i^{(2)} & x_i^{(2)} y_i^{(2)} \\ 1 & x_i^{(3)} & y_i^{(3)} & x_i^{(3)} y_i^{(3)} \\ 1 & x_i^{(4)} & y_i^{(4)} & x_i^{(4)} y_i^{(4)} \end{bmatrix}^{-1} \{p\}_i \\ &= [J]_i \{p\}_i \end{aligned} \quad (5-244)$$

Substituting this into Equation 5-239, we have

$$p_z(x, y, t) = \{1 \ x \ y \ x y\} [J]_i \{p\}_i \quad (5-245)$$

for (x,y) on the ith region

Contrails

The kinetic energy can be written as the sum over the individual regions

$$\tau = \frac{1}{2} \sum_{i=1}^N \iint_{S_i} m(x,y) \left(\frac{\partial \phi_i}{\partial t} \right)^2 dx dy \quad (5-246)$$

In the i^{th} region

$$\frac{\partial \phi_i}{\partial t} = \{ \dot{\phi} \}'_i [J]_i \begin{bmatrix} 1 \\ x \\ y \\ xy \end{bmatrix} \quad (5-247)$$

Substitution into Equation 5-238 gives

$$\begin{aligned} \tau &= \frac{1}{2} \sum_{i=1}^N \{ \dot{\phi} \}'_i [J]_i \iint_{S_i} \begin{bmatrix} 1 & x & y & xy \\ x & x^2 & xy & x^2y \\ y & xy & y^2 & xy^2 \\ xy & x^2y & xy^2 & x^2y^2 \end{bmatrix} m(x,y) dx dy [J]_i \{ \dot{\phi} \}_i \\ &= \frac{1}{2} \sum_{i=1}^N \{ \dot{\phi} \}'_i [A]_i \{ \dot{\phi} \}_i \end{aligned} \quad (5-248)$$

where

$$[A]_i = [J]_i \iint_{S_i} \begin{bmatrix} 1 & x & y & xy \\ x & x^2 & xy & x^2y \\ y & xy & y^2 & xy^2 \\ xy & x^2y & xy^2 & x^2y^2 \end{bmatrix} m(x,y) dx dy [J]_i \quad (5-249)$$

which can be evaluated by numerical integration.

Using Equation 5-242, we obtain

$$\tau = \frac{1}{2} \{ \dot{\phi} \}' [A] \{ \dot{\phi} \} \quad (5-250)$$

where

$$[A] = \sum_{i=1}^N [T]_i' [A]_i [T]_i \quad (5-251)$$

5.1.2.4 Inertia Matrices for Complex Structures

When the routine method of structural analysis, discussed in Paragraph 5.1.1.1, is used, the inertia matrices for the whole structure may be obtained as a by-product of the direct stiffness approach. If $\{q\}_{ij}$ are the coordinates of an element and the kinetic energy of the element is written in the form

$$T_{ij} = \frac{1}{2} \dot{\{q\}}_{ij}' [M]_{ij} \dot{\{q\}}_{ij} \quad (5-252)$$

where $[M]_{ij}$ is the element inertia matrix, then from Equation 5-45, we have

$$\{q\}_{ij} = [T]_{ij} [\tau]_j [T]_j \{p\} \quad (5-253)$$

and substitution into Equation 5-252, using

$$T = \sum_j \sum_i T_{ij}$$

gives

$$T = \frac{1}{2} \dot{\{p\}}' [A] \dot{\{p\}} \quad (5-254)$$

where

$$[A] = \sum_j \sum_i [T]_i' [T]_j [T]_j' [M]_{ij} [T]_i [T]_j [T]_j \quad (5-255)$$

5.1.3 The Methods of Modal Coupling

5.1.3.1 Introduction - A Summary of the General Vibration Problem

If $\{p\}$ is a set of generalized coordinates for a complete structural system, then the methods of Paragraph 5.1.1 and Paragraph 5.1.2 give the kinetic energy and strain energy in the following form:

$$T = \frac{1}{2} \dot{\{p\}}' [A] \dot{\{p\}} \quad (5-256)$$

$$U = \frac{1}{2} \{p\}' [K] \{p\} \quad (5-257)$$

The theoretical details involved in the vibration problem have been considered in Section 2.2. The equation governing the vibration modes and frequencies has been shown to be

$$[E] [A] \{p\} = \lambda \{p\} \quad (5-258)$$

Contrails

where $[E] = [K]^{-1}$ for restrained systems. If the system is unrestrained, the elastic vibration modes are governed by

$$([r]'[E][r])A\{\varphi\} = \lambda\{\varphi\} \quad (5-259)$$

where

$$[r] = [1] - [A][\varphi_R][\varphi_R]'[A][\varphi_R][\varphi_R]' \quad (5-260)$$

and

$$[E] = [S][S]'[K][S][S]' \quad (5-261)$$

If λ_i $i = 1, 2, \dots$ are the solutions for λ from Equation 5-258 or Equation 5-259, the vibration frequencies are given by

$$\omega_i = \sqrt{\frac{1}{\lambda_i}} \quad (5-262)$$

The solutions of the problem can be used as a transformation to a new set of generalized coordinates, called modal coordinates.

$$\{p\} = \sum_{i=1}^M \{\varphi\}_i q_i = [\varphi]\{q\} \quad (5-263)$$

In the analysis for vibration modes and frequencies of very large and complex systems, the number of degrees-of-freedom, N , required often exceeds the capacity of a computer to handle the resulting $N \times N$ inertia and influence matrices. In those cases the system can be broken down into component pieces, the modes of the pieces obtained, and then these modes coupled together in a systematic procedure. This procedure is discussed below for two important cases.

5.1.3.2 Modal Coupling of Elastically Uncoupled Components

The concept of modal coupling is introduced, first, for the case where it has the greatest practical utility. This is the case when it is possible to decompose the structure into large components which are "elastically uncoupled." Two systems are said to be "elastically uncoupled" when strain energy can be stored in one system without inducing deformations in the other system. Figure 92 is a schematic description of two elastically uncoupled components of a system.

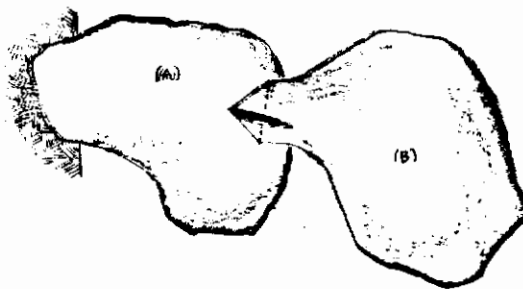

FIGURE 92 TWO ELASTICALLY UNCOUPLED COMPONENTS

The figure is intended to convey the fact that deformations in (A) produce only rigid body displacements in (B).

If we let $\{p_A\}$ be a set of generalized coordinates describing the configuration of the first component, and $\{p_B\}$ be a set of generalized coordinates describing the configuration of the second component, then we have

$$T = \frac{1}{2} \{\dot{p}_A\}' [A_A] \{\dot{p}_A\} + \frac{1}{2} \{\dot{p}_B\}' [A_B] \{\dot{p}_B\} \quad (5-264)$$

and

$$U = \frac{1}{2} \{p_A\}' [K_A] \{p_A\} + \frac{1}{2} \{p_B\}' [K_B] \{p_B\} \quad (5-265)$$

We further suppose that the coordinates, $\{p_B\}$, are not consistent with the constraints imposed on (B) by (A). On this assumption, $\{p_B\}$ includes rigid body degrees-of-freedom and hence $[K_B]$ is singular.

If (B) is rigid, then its displacements can be uniquely related to (A) by a transformation that depends only on the geometry of the system:

$$\{p_B\} = [T_{BA}] \{p_A\} \quad (5-266)$$

The elastic displacements of (B) when (A) is motionless can be written (see also Figure 93)

$$\{p_B\} = [\phi_B] \{q_B\} \quad (5-267)$$

where $[\phi_B]$ is a matrix of modes of (B) constrained by (A) which satisfy the equation

Constraints

$$[E_B][A_B]\{\varphi\} = \lambda\{\varphi\} \quad (5-268)$$

where

$$[E_B] = [S_B]([S_B]'[K_B][S_B])^{-1}[S_B]' \quad (5-269)$$

and $[S_B]$ is a constraint matrix describing the constraints imposed on (B) by (A) when $\{P_A\} = 0$

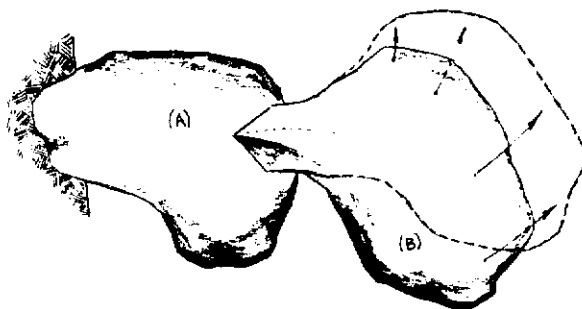

FIGURE 93 DISPLACEMENTS OF (B) WITH (A) MOTIONLESS

The total displacement of (B) can then be written

$$\{p_B\} = \underbrace{[\tau_{BA}]\{p_A\}} + \underbrace{[q_B]\{q_B\}} \quad (5-270)$$

Displacements of (B) due to motion of (A) Elastic displacements of (B) relative to (A)

The general form of the geometric transformation matrix can be constructed as follows. If $\xi, \eta, \zeta, \phi, \theta,$ and ψ are three displacements and three rotations of a point on (A) that is also on the region in contact with (B), then these can be uniquely related to the generalized coordinates describing the configuration of (A):

Contrails

$$\begin{aligned}
 \xi &= \{ \gamma_{\xi} \}' \{ p_A \} \\
 \eta &= \{ \gamma_{\eta} \}' \{ p_A \} \\
 \zeta &= \{ \gamma_{\zeta} \}' \{ p_A \} \\
 \phi &= \{ \gamma_{\phi} \}' \{ p_A \} \\
 \theta &= \{ \gamma_{\theta} \}' \{ p_A \} \\
 \psi &= \{ \gamma_{\psi} \}' \{ p_A \}
 \end{aligned}
 \tag{5-271}$$

The coefficients can be derived by a suitable interpolation such as has been discussed in Section 2.3. The displacements of (B) when it is rigid can be written as

$$\begin{aligned}
 \{ p_B \} &= \{ \phi_{\xi} \} \xi + \{ \phi_{\eta} \} \eta + \{ \phi_{\zeta} \} \zeta \\
 &\quad + \{ \phi_{\phi} \} \phi + \{ \phi_{\theta} \} \theta + \{ \phi_{\psi} \} \psi
 \end{aligned}
 \tag{5-272}$$

where the columns are "rigid body" modes. For example, $\{ \phi_{\xi} \}$, are the values of the generalized coordinates for $\xi = 1$ while $\eta = \zeta = \phi = \theta = \psi = 0$. Substitution of Equations 5-271 into 5-272 gives

$$\{ p_B \} = \begin{bmatrix} \{ \phi_{\xi} \} & \{ \phi_{\eta} \} & \{ \phi_{\zeta} \} & \{ \phi_{\phi} \} & \{ \phi_{\theta} \} & \{ \phi_{\psi} \} \end{bmatrix} \begin{bmatrix} \{ \gamma_{\xi} \}' \\ \{ \gamma_{\eta} \}' \\ \{ \gamma_{\zeta} \}' \\ \{ \gamma_{\phi} \}' \\ \{ \gamma_{\theta} \}' \\ \{ \gamma_{\psi} \}' \end{bmatrix} \{ p_A \}
 \tag{5-273}$$

or

$$\{ p_B \} = [T_{BA}] \{ p_A \}
 \tag{5-274}$$

If we assume, for conceptual simplicity, that (A) is constrained, then the influence coefficients for (A) are given by

$$[E_A] = [K_A]^{-1}
 \tag{5-275}$$

Now, the total kinetic energy, when (B) is rigid, is given by

$$\begin{aligned}
 T &= \frac{1}{2} \dot{p}_A' [A_A] \dot{p}_A + \frac{1}{2} \dot{p}_A' [T_{BA}] [A_B] [T_{BA}] \dot{p}_A \\
 &= \frac{1}{2} \dot{p}_A' \left([A_A] + [T_{BA}] [A_B] [T_{BA}] \right) \dot{p}_A
 \end{aligned}
 \tag{5-276}$$

and the vibration modes with (B) rigid are governed by

$$[E_A] \left([A_A] + [T_{BA}] [A_B] [T_{BA}] \right) \{ \varphi \} = \lambda \{ \varphi \}
 \tag{5-277}$$

If we denote the matrix of these solutions by $[\phi_A]$, we have, in summary:

Contrails

$$\{p_A\} = [\varphi_A] \{q_A\} \quad (5-278)$$

$$\{p_B\} = [\varphi_B] \{q_B\} + [\tau_{BA}] [\varphi_A] \{q_A\} \quad (5-279)$$

or

$$\begin{bmatrix} \{p_A\} \\ \{p_B\} \end{bmatrix} = [\Phi] \begin{bmatrix} \{q_A\} \\ \{q_B\} \end{bmatrix} \quad (5-280)$$

where

$$[\Phi] = \begin{bmatrix} [\varphi_A], & [0] \\ [\tau_{BA}] [\varphi_A], & [\varphi_B] \end{bmatrix} \quad (5-281)$$

If we introduce

$$\{q_c\} = \begin{bmatrix} \{q_A\} \\ \{q_B\} \end{bmatrix} \quad (5-282)$$

then the kinetic energy, using Equation 5-280, is

$$\begin{aligned} T &= \frac{1}{2} \{ \dot{p}_A \}^T \{ \dot{p}_B \}^T \begin{bmatrix} [A_A] & [0] \\ [0] & [A_B] \end{bmatrix} \begin{bmatrix} \dot{p}_A \\ \dot{p}_B \end{bmatrix} \\ &= \frac{1}{2} \{ \dot{q}_c \}^T [\Phi]^T \begin{bmatrix} [A_A] & [0] \\ [0] & [A_B] \end{bmatrix} [\Phi] \{ \dot{q}_c \} \end{aligned} \quad (5-283)$$

or

$$T = \frac{1}{2} \{ \dot{q}_c \}^T [M] \{ \dot{q}_c \} \quad (5-284)$$

where

$$[M] = [\Phi]^T \begin{bmatrix} [A_A] & [0] \\ [0] & [A_B] \end{bmatrix} [\Phi] \quad (5-285)$$

which is called the "modal mass matrix." The modal stiffness matrix is found in an analogous manner.

Since

$$[\tau_{BA}] \{p_A\}$$

represents a rigid displacement of (B), we must conclude that

$$[K_B] ([\tau_{BA}] \{p_A\}) = \{0\} \quad (5-286)$$

Contrails

Further, since the coordinates, $\{p_A\}$, are independent, we have the much stronger relation

$$[K_B][T_{BA}] = [0] \quad (5-287)$$

The total strain energy of the system is

$$\begin{aligned} U &= \frac{1}{2} \{p_A\}' \{p_B\}' \begin{bmatrix} [K_A] & [0] \\ [0] & [K_B] \end{bmatrix} \begin{Bmatrix} \{p_A\} \\ \{p_B\} \end{Bmatrix} \\ &= \frac{1}{2} \{q_c\}' [\Phi]' \begin{bmatrix} [K_A] & [0] \\ [0] & [K_B] \end{bmatrix} [\Phi] \{q_c\} \end{aligned} \quad (5-288)$$

or

$$U = \frac{1}{2} \{q_c\}' [F] \{q_c\} \quad (5-289)$$

where

$$[F] = [\Phi]' \begin{bmatrix} [K_A] & [0] \\ [0] & [K_B] \end{bmatrix} [\Phi] \quad (5-290)$$

which can be expanded using Equation 5-281

$$[F] = \begin{bmatrix} [\varphi_A]'([K_A] + [T_{BA}]'[K_B][T_{BA}])[\varphi_A] & [\varphi_A]'[T_{BA}]'[K_B][\varphi_B] \\ [\varphi_B]'[K_B][T_{BA}][\varphi_A] & [\varphi_B]'[K_B][\varphi_B] \end{bmatrix} \quad (5-291)$$

Using Equation 5-287, this reduces to

$$[F] = \begin{bmatrix} [\varphi_A]'[K_A][\varphi_A] & [0] \\ [0] & [\varphi_B]'[K_B][\varphi_B] \end{bmatrix} \quad (5-292)$$

Contrails

Now, from general properties of the vibration equations (see Paragraph 2.2.3.2, Equation 2-179), we have

$$[\varphi_A]' [K_A] [\varphi_A] = r / \lambda_A \quad (5-293)$$

$$[\varphi_B]' [K_B] [\varphi_B] = r / \lambda_B \quad (5-294)$$

So that the total "modal stiffness matrix" for an elastically uncoupled system is a diagonal matrix

$$[F] = \begin{bmatrix} r / \lambda_A & & \\ & r / \lambda_B & \\ & & \dots \end{bmatrix} \quad (5-295)$$

We then have

$$T = \frac{1}{2} \{ \dot{q}_c \}' [M] \dot{q}_c \quad (5-296)$$

$$U = \frac{1}{2} \{ q_c \}' [F] q_c \quad (5-297)$$

and Lagrange's equations give

$$[M] \ddot{q}_c + [F] q_c = \{ 0 \} \quad (5-298)$$

Assuming a separated solution,

$$\{ q_c \} = \{ \pi \} q_f \quad (5-299)$$

leads to

$$[G] [M] \ddot{\pi} = \lambda \{ \pi \} \quad (5-300)$$

where the "modal influence coefficient matrix" is given by

$$[G] = [F]^{-1} = \begin{bmatrix} \lambda_A & & \\ & \lambda_B & \\ & & \dots \end{bmatrix} \quad (5-301)$$

Contrails

The matrix of eigenvectors to this problem is commonly called "modal mode-shapes." This is used to express the natural vibration modes of the coupled system in the form

$$\begin{bmatrix} \{p_A\} \\ \{p_B\} \end{bmatrix} = [\Phi][\pi]\{q\} \quad (5-302)$$

or simply

$$\{p\} = [\varphi]\{q\} \quad (5-303)$$

where

$$\{p\} = \begin{bmatrix} \{p_A\} \\ \{p_B\} \end{bmatrix} \quad (5-304)$$

and

$$[\varphi] = \text{matrix of natural modes} = [\Phi][\pi] \quad (5-305)$$

The generality and practical utility of this procedure cannot be over-emphasized. This concept can be used to obtain vibration modes on very complicated structures by iterating moderately small eigenvalue problems, reducing the number of degrees-of-freedom, and then solving the complete problem in terms of modal coordinates for the individual components.

The procedure of modal coupling is used in the example analysis of the Saturn vehicle in Appendix II.

5.1.3.3 Modal Coupling of Elastically Coupled Systems

The procedure in this case is very similar to that of the previous section with the exception that there are additional constraint relations between the coordinates of (A) and the coordinates of (B). Figure 94 is a schematic of a system that is "almost" elastically uncoupled.

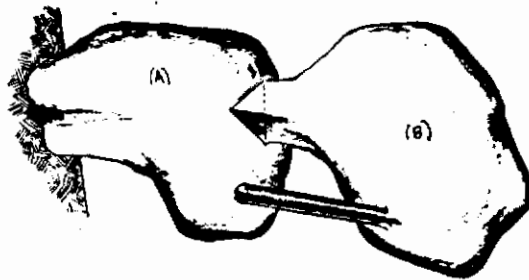

FIGURE 94 TWO ELASTICALLY COUPLED COMPONENTS

If $\{p_A\}$ and $\{p_B\}$ are coordinates for the components and $\{p_B\}$ is not consistent with any of the constraints imposed on (B) by (A), we have the following equations which describe the structural continuity between (A) and (B) at points of connection which cause the components to be elastically coupled:

$$[L_A]\{p_A\} = [L_B]\{p_B\} \quad (5-306)$$

As in the preceding section, we have

$$\begin{aligned} \{p_A\} &= [\phi_A]\{q_A\} \\ \{p_B\} &= [\tau_{BA}]\{p_A\} + [\phi_B]\{q_B\} \end{aligned} \quad (5-307)$$

where both $[\phi_A]$ and $[\phi_B]$ are derived with all connections between (A) and (B) relaxed except those just sufficient to restrain (B). It follows then that $\{q_A\}$ and $\{q_B\}$ are also not consistent with the constraints.

If we substitute Equation 5-307 into Equation 5-306, we obtain

$$[[L_A], -[L_B]][\phi] \begin{Bmatrix} \{q_A\} \\ \{q_B\} \end{Bmatrix} = \{0\} \quad (5-308)$$

Constraints

where $[\Phi]$ is the matrix introduced in Equation 5-280. We can also write this as

$$[L] \begin{Bmatrix} \{q_A\} \\ \{q_B\} \end{Bmatrix} = \{0\} \quad (5-309)$$

where

$$[L] = [[L_A], -[L_B]][\Phi] \quad (5-310)$$

Using these constraint equations, we may select some of the modal coordinates and eliminate them in such a manner that the remaining coordinates satisfy the constraints explicitly. Let q_O be the coordinates to be eliminated and let q_C be the remaining coordinates, then

$$\begin{Bmatrix} \{q_A\} \\ \{q_B\} \end{Bmatrix} = [T_O] \{q_O\} + [T_C] \{q_C\} \quad (5-311)$$

where the transformations are appropriate matrices of zero's and one's. Substitution into Equation 5-309 gives

$$[L][T_O] \{q_O\} + [L][T_C] \{q_C\} = \{0\} \quad (5-312)$$

Solving for $\{q_O\}$ gives

$$\{q_O\} = -([L][T_O])^{-1}([L][T_C]) \{q_C\} \quad (5-313)$$

Substitution into Equation 5-311 gives

$$\begin{Bmatrix} \{q_A\} \\ \{q_B\} \end{Bmatrix} = ([T_C] - [T_O]([L][T_O])^{-1}[L][T_C]) \{q_C\} \quad (5-314)$$

or

$$\begin{Bmatrix} \{q_A\} \\ \{q_B\} \end{Bmatrix} = [T] \{q_C\} \quad (5-315)$$

Contrails

The matrix, $[T]$, is a compatibility matrix in the same sense as the compatibility matrices introduced in the Direct Stiffness Method of Structural Analysis (see Paragraph 5.1.1.1, Equation 5-17). As in the previous section, we have

$$T = \frac{1}{2} [\{\dot{q}_A\}' \{\dot{q}_B\}'] [\Phi]' \begin{bmatrix} [A_A] & [0] \\ [0] & [A_B] \end{bmatrix} [\Phi] \begin{bmatrix} \{\dot{q}_A\} \\ \{\dot{q}_B\} \end{bmatrix} \quad (5-316)$$

$$U = \frac{1}{2} [\{q_A\}' \{q_B\}'] \begin{bmatrix} r_{\lambda_A} & \\ & r_{\lambda_B} \end{bmatrix} \begin{bmatrix} \{q_A\} \\ \{q_B\} \end{bmatrix} \quad (5-317)$$

Substitution of Equation 5-315 into these expressions gives

$$T = \frac{1}{2} \{\dot{q}_c\}' [M] \{\dot{q}_c\} \quad (5-318)$$

$$U = \frac{1}{2} \{q_c\}' [F] \{q_c\} \quad (5-319)$$

where

$$[M] = [T]' [\Phi]' \begin{bmatrix} [A_A] & [0] \\ [0] & [A_B] \end{bmatrix} [\Phi] [T] \quad (5-320)$$

and

$$[F] = [T]' \begin{bmatrix} r_{\lambda_A} & \\ & r_{\lambda_B} \end{bmatrix} [T] \quad (5-321)$$

The modal influence coefficients are $[G] = [F]^{-1}$. The "modal mode-shapes" are obtained from the equations

$$[G][M]\{\pi\} = \lambda \{\pi\} \quad (5-322)$$

and the displacements in the modes are

$$\begin{bmatrix} \{p_A\} \\ \{p_B\} \end{bmatrix} = [\Phi][\tau][\pi]q \quad (5-323)$$

or

$$\{p\} = [\varphi]q \quad (5-324)$$

where

$$[\varphi] = [\Phi][\tau][\pi] \quad (5-325)$$

An example which better illustrates the procedure is given in Appendix II, Paragraph .

5.2 VIBRATION PROBLEMS IN LAUNCH VEHICLE STRUCTURES

5.2.1 A Numerical Study and Comparison of Methods to Obtain Vibration Modes for Straight Beams

This section describes some studies conducted to evaluate and compare several finite degree-of-freedom methods available for the vibration analysis of beams. All of the methods are compared for the case of a straight, uniform beam. The numerical results are given for a cantilever constraint and for the free beam.

The study is restricted to what is commonly called the "Euler-Bernoulli" theory of beams¹ governed by

$$\tau = \frac{1}{2} \int_0^L m(x) \left(\frac{\partial p}{\partial t} \right)^2 dx \quad (5-326)$$

$$U = \frac{1}{2} \int_0^L EI(x) \left(\frac{\partial^2 p}{\partial x^2} \right)^2 dx \quad (5-327)$$

which has been briefly discussed in Paragraph 2.3.3.1. In this section we consider only the case of the uniform beam where $EI(x) = EI$, a constant and $m(x) = m$, a constant. The geometry of the system is shown in Figure 95.

¹Important deviations from this theory are considered in Paragraph 5.2.2.1.

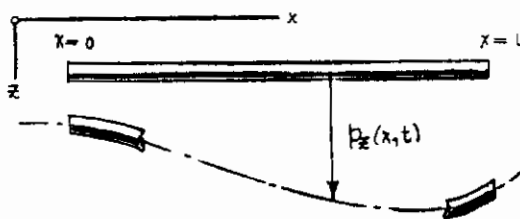

FIGURE 95 UNIFORM STRAIGHT BEAM

In all of the finite degree-of-freedom studies, the generalized coordinates will be the lateral displacements at eleven (11) equally spaced collocation points. The generalized coordinates are then

$$p_i(t) = p_z(x_i, t) \tag{5-328}$$

$$i = 0, 1, 2, \dots, 10$$

The points divide the beam into ten (10) equal intervals of length,

$$\ell = \frac{L}{10} \tag{5-329}$$



FIGURE 96 COLLOCATION POINTS

The methods to be considered are:

- (1) Influence coefficients from complementary energy inertia matrix by diparabolic interpolation
- (2) Influence coefficients from complementary energy inertia matrix by trapezoidal interpolation
- (3) Influence coefficients by diparabolic interpolation inertia matrix by diparabolic interpolation
- (4) Influence coefficients from the direct stiffness method inertia matrix consistent with the direct stiffness method
- (5) Influence coefficients from the direct stiffness method inertia matrix by diparabolic interpolation

- (6) The exact solution of the partial differential equation for the continuous case.

These methods are considered separately in the sections that follow. The results are summarized and compared in Paragraph 5.2.2.1.2.

5.2.1.1 The Exact Solution for the Continuous Beam

The exact solution may be obtained from Equations 5-326 and 5-327 by the use of Hamilton's Principle. For the case of a system that is both conservative and holonomic, this principle can be obtained from the more general Principle of Virtual Work stated in Paragraph 2.1.1.3 (see Equation 2-33). Hamilton's Principle states:

$$\delta \int_{t_1}^{t_2} (T-U) dt = 0 \quad (5-330)$$

where, in our particular case,

$$T-U = \int_0^L \left(\frac{m}{2} \left(\frac{\partial p_z}{\partial t} \right)^2 - \frac{EI}{2} \left(\frac{\partial^2 p_z}{\partial x^2} \right)^2 \right) dx \quad (5-331)$$

This is a problem in the Calculus of Variations which yields¹

$$\int_{t_1}^{t_2} \left[EI \left(\frac{\partial^3 p_z}{\partial x^3} \right) \delta \frac{\partial p_z}{\partial x} - EI \frac{\partial}{\partial x} \left(\frac{\partial^2 p_z}{\partial x^2} \right) \delta p_z \right]_0^L \quad (5-332)$$

$$\int_0^L \left(\frac{d}{dt} \left(m \frac{\partial p_z}{\partial t} \right) - \frac{\partial}{\partial x^2} \left(EI \frac{\partial^2 p_z}{\partial x^2} \right) \right) \delta p_z dx dt = 0$$

We want to consider only two cases in this section. First, for the beam clamped at $x = L$, we have

$$p_z(L,t) = 0 \quad (5-333)$$

$$\frac{\partial p_z}{\partial x}(L,t) = 0 \quad (5-334)$$

and Equation 5-332 then requires

$$\frac{\partial^2 p_z}{\partial x^2}(0,t) = 0 \quad (5-335)$$

¹The complete details of this problem are discussed by R. Weinstock, Calculus of Variations, McGraw-Hill, 1952, Section 10-5, p. 217. In particular, equation (64).

Contrails

$$\frac{\partial^3 p_z}{\partial x^3}(0, t) = 0 \quad (5-336)$$

$$m \frac{\partial^2 p_z}{\partial t^2} - EI \frac{\partial^4 p_z}{\partial x^4} = 0 \quad (5-337)$$

In the second case, for the beam unconstrained, Equation 5-332 requires

$$\frac{\partial^2 p_z}{\partial x^2}(0, t) = 0 \quad (5-338)$$

$$\frac{\partial^3 p_z}{\partial x^3}(0, t) = 0 \quad (5-339)$$

$$\frac{\partial^2 p_z}{\partial x^2}(L, t) = 0 \quad (5-340)$$

$$\frac{\partial^3 p_z}{\partial x^3}(L, t) = 0 \quad (5-341)$$

$$m \frac{\partial^2 p_z}{\partial t^2} - EI \frac{\partial^4 p_z}{\partial x^4} = 0 \quad (5-342)$$

The equations can be solved by separation of variables in either case. If we assume

$$p_z(x, t) = \varphi(x) q(t) \quad (5-343)$$

then we have

$$m \varphi(x) \ddot{q}(t) - EI \frac{d^4 \varphi}{dx^4} q(t) = 0 \quad (5-344)$$

which requires that

$$-\frac{q}{\ddot{q}} \frac{EI}{mL^4} = \text{a constant, say, } \lambda \quad (5-345)$$

In the case of the clamped beam, we have

$$\begin{aligned} \lambda L^4 \frac{d^4 \varphi}{dx^4} + \varphi &= 0 \\ \varphi(0) &= 0 & \frac{d^2 \varphi}{dx^2}(0) &= 0 \\ \frac{d\varphi}{dx}(L) &= 0 & \frac{d^3 \varphi}{dx^3}(0) &= 0 \end{aligned} \quad (5-346)$$

while in the case of the unrestrained beam, we have

$$\begin{aligned} \lambda L^4 \frac{d^4 \varphi}{dx^4} + \varphi &= 0 & (5-347) \\ \frac{d^4 \varphi}{dx^4}(L) = 0 & \quad \frac{d^4 \varphi}{dx^4}(0) = 0 \\ \frac{d^3 \varphi}{dx^3}(L) = 0 & \quad \frac{d^3 \varphi}{dx^3}(0) = 0 \end{aligned}$$

The solution to these equations is well known and has been tabulated in a convenient form by Dana Young and Robert P. Felgar¹. The solutions,

$$(5-348)$$

$$\lambda = \lambda_i \quad i = 1, 2, \dots$$

$$(5-349)$$

$$\varphi = \varphi_i(x) \quad i = 1, 2, \dots$$

are compared with the finite degree-of-freedom solutions in Paragraph 5.2.1.6.

5.2.1.2 Influence Coefficients by the Direct Stiffness Method

If we write

$$U_i = \frac{1}{2} \int_{x_{i-1}}^{x_i} EI \left(\frac{\partial^2 p_x}{\partial x^2} \right)^2 dx \quad x_i - x_{i-1} = \ell = \frac{L}{10} \quad (5-350)$$

then, from Equation 5-327,

$$U = \sum_{i=1}^N U_i \quad (N=10) \quad (5-351)$$

Now, the bending moment in the beam is

$$\begin{aligned} M &= - \iint z \sigma_{xx} dy dz = - \iint z E \epsilon_{xx} dy dz & (5-352) \\ &= - \iint z E \left(-z \frac{\partial^2 p_x}{\partial x^2} \right) dy dz \\ &= \iint E z^2 dy dz \frac{\partial^2 p_x}{\partial x^2} = EI \frac{\partial^2 p_x}{\partial x^2} \end{aligned}$$

¹Young, D. and, Felgar, R. P., Tables of Characteristic Functions Representing Normal Modes of Vibration of a Beam, University of Texas Publication No. 4913, July 1, 1949.

and hence,

$$U_i = \frac{1}{2} \int_{x_{i-1}}^{x_i} \frac{M^2}{EI} dx \quad (5-353)$$

If we let

$$\xi = x_i - x \quad (5-354)$$

then

$$U_i = \frac{1}{2} \int_0^l \frac{M^2(\xi)}{EI} d\xi \quad (5-355)$$

If we assume the element is only loaded at the ends, then, on the i^{th} interval,

$$M(\xi) = M_i + \xi V_i \quad (5-356)$$

where V_i and M_i are the shear and bending moment just to the left of $x = x_i$.

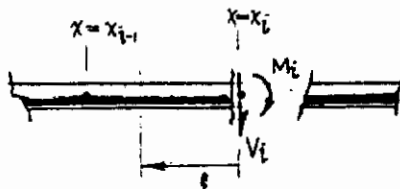

FIGURE 97 TYPICAL ELEMENT

From Equation 5-356,

$$M^2(\xi) = \{V_i \ M_i\} \begin{bmatrix} \xi \\ 1 \end{bmatrix} \frac{1}{2} \begin{bmatrix} V_i \\ M_i \end{bmatrix} \quad (5-357)$$

Substitution into Equation 5-355 gives

$$U_i = \frac{1}{2} \{V_i \ M_i\} \int_0^l \frac{1}{EI} \begin{bmatrix} \xi^2 & \xi \\ \xi & 1 \end{bmatrix} d\xi \begin{bmatrix} V_i \\ M_i \end{bmatrix} \quad (5-358)$$

Performing the indicated integration gives

$$U_i = \frac{1}{2} \{L\}_i^T [G]_i \{L\}_i \quad (5-359)$$

where

$$[G]_i = \begin{bmatrix} \frac{l^3}{3EI} & \frac{l^2}{2EI} \\ \frac{l^2}{2EI} & \frac{l}{EI} \end{bmatrix} \quad (5-360)$$

and

$$\{L\}_i = \begin{bmatrix} V_i \\ M_i \end{bmatrix} \quad (5-361)$$

Now, if we denote all the loads acting on the i^{th} element by $\{Q\}_i$, we have

$$\{Q\}_i = \begin{bmatrix} Q_1^{(i)} \\ Q_2^{(i)} \\ Q_3^{(i)} \\ Q_4^{(i)} \end{bmatrix} \quad (5-362)$$

where the loads are shown in Figure 98.

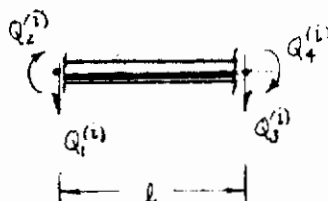

FIGURE 98 LOADS ON AN ELEMENT

We note here that

$$V_i = Q_3^{(i)} \quad (5-363)$$

$$M_i = Q_4^{(i)} \quad (5-364)$$

Also, from equilibrium of the element, we have

$$Q_1^{(i)} = -Q_3^{(i)} \quad (5-365)$$

$$Q_2^{(i)} = -lQ_3^{(i)} - Q_4^{(i)} \quad (5-366)$$

Using Equations 5-363 and 5-364, this may be written as

$$\{Q\}_i = \begin{bmatrix} Q_1^{(i)} \\ Q_2^{(i)} \\ Q_3^{(i)} \\ Q_4^{(i)} \end{bmatrix} = \begin{bmatrix} -1 & 0 \\ -l & -1 \\ 1 & 0 \\ 0 & 1 \end{bmatrix} \begin{bmatrix} V_i \\ M_i \end{bmatrix} = [V]_i \{L\}_i \quad (5-367)$$

where

$$[V]_i = \begin{bmatrix} -1 & 0 \\ -l & -1 \\ 1 & 0 \\ 0 & 1 \end{bmatrix} \quad (5-368)$$

If v_i and m_i are the generalized coordinates associated with V_i and M_i and we let

$$\{L\}_i = \begin{bmatrix} v_i \\ m_i \end{bmatrix} \quad (5-369)$$

then the virtual work of the stress resultants is

$$\delta W = \{\delta L\}_i^T \{L\}_i \quad (5-370)$$

but also

$$\delta W = \{\delta Q\}_i^T \{Q\}_i \quad (5-371)$$

and, from Equation 5-367,

$$\delta W = \{\delta q\}'_i [V]_i \{\delta L\}_i \quad (5-372)$$

By comparison with Equation 5-370, we conclude

$$\{\delta L\}'_i = \{\delta q\}'_i [V]_i \quad (5-373)$$

or

$$\{\delta L\}_i = [V]_i' \{\delta q\}_i \quad (5-374)$$

Expanding this, using Equation 5-368, gives

$$r_i = q_3^{(i)} - q_1^{(i)} - l q_2^{(i)} \quad (5-375)$$

$$m_i = \delta_4^{(i)} - \delta_2^{(i)} \quad (5-376)$$

which indicates that the generalized coordinates associated with the stress resultants are relative displacements between the ends of the element.

From Equation 5-359 and Castigliano's theorem, we have

$$\{\delta L\}_i = \left\{ \frac{\partial U}{\partial L} \right\} = [G]_i' \{\delta L\}_i \quad (5-377)$$

so that

$$\{\delta L\}_i = [G]_i^{-1} \{\delta L\}_i \quad (5-378)$$

Using Equation 5-374, we obtain

$$\{\delta L\}_i = [G]_i^{-1} [V]_i' \{\delta q\}_i \quad (5-379)$$

and substitution into Equation 5-359 gives

$$U_i = \frac{1}{2} \{\delta q\}'_i [V]_i [G]_i^{-1} [G]_i [G]_i^{-1} [V]_i' \{\delta q\}_i \quad (5-380)$$

Contrails

or

$$U_i = \frac{1}{2} \{q\}_i^T [F]_i \{q\}_i \quad (5-381)$$

where

$$[F]_i = [V]_i [G]_i^{-1} [V]_i^T \quad (5-382)$$

Expanding this using Equations 5-360 and 5-368 gives

$$[F]_i = \frac{EI}{l^3} \begin{bmatrix} 12 & 6l & -12 & 6l \\ 6l & 4l^3 & -6l & 2l^3 \\ -12 & -6l & 12 & -6l \\ 6l & 2l^3 & -6l & 4l^3 \end{bmatrix} \quad (5-383)$$

The compatibility relations for the beam are that slope and displacement are continuous across the boundary between elements. If q_i ($i = 1, 2, \dots, 11$) are the common displacements at the points $x = x_i$, then

$$\begin{aligned} q_1^{(1)} &= q_1 \\ q_3^{(1)} &= q_1^{(2)} = q_2 \\ q_2^{(2)} &= q_1^{(3)} = q_3 \\ &\vdots \\ q_3^{(9)} &= q_1^{(10)} = q_{10} \\ q_3^{(10)} &= q_{11} \end{aligned} \quad (5-384)$$

If q_i $i = 12, 13, \dots, 22$ are the common slopes at $x = x_i$, then

Contrails

(5-385)

$$\begin{aligned}
 q_2^{(1)} &= q_{12} \\
 q_4^{(1)} &= q_2^{(2)} = q_{13} \\
 q_4^{(2)} &= q_2^{(3)} = q_{14} \\
 &\vdots \\
 q_4^{(9)} &= q_2^{(10)} = q_{21} \\
 q_{j4}^{(10)} &= q_{22}
 \end{aligned}$$

These relations can be written as

$$\{q_j\}_i = [\tau]_i \{q\} \quad (5-386)$$

$$i = 1, 2, \dots, 10$$

where

$$\{q\} = \begin{bmatrix} q_1 \\ q_2 \\ \vdots \\ q_{11} \\ q_{12} \\ q_{13} \\ \vdots \\ q_{22} \end{bmatrix} \quad (5-387)$$

For example, for $i = 1$:

$$\{q_j\}_1 = \begin{bmatrix} q_1^{(1)} \\ q_2^{(1)} \\ q_4^{(1)} \\ q_4^{(2)} \\ q_4^{(9)} \end{bmatrix} = \begin{bmatrix} 1 & 0 & 0 & \dots & 0 & 0 & 0 & 0 & \dots & 0 \\ 0 & 0 & 0 & 0 & 0 & 1 & 0 & 0 & 0 & 0 \\ 0 & 1 & 0 & 0 & 0 & 0 & 0 & 0 & 0 & 0 \\ 0 & 0 & 0 & \dots & 0 & 0 & 1 & 0 & \dots & 0 \end{bmatrix} \{q\} \quad (5-388)$$

Contrails

Substitution of Equation 5-386 into Equation 5-381 gives

$$U = \sum_{i=1}^N U_i = \frac{1}{2} \{q\}' \sum_{i=1}^{10} [T]_i' [F]_i [T]_i \{q\} \quad (5-389)$$

or

$$U = \frac{1}{2} \{q\}' [F] \{q\} \quad (5-390)$$

where

$$[F] = \sum_{i=1}^{10} [T]_i' [F]_i [T]_i \quad (5-391)$$

If we choose as external coordinates the eleven displacements at the points $x = x_i$, then $p_i \equiv q_i$ for $i = 1, 2, \dots, 11$ and from the general theory in Paragraph 5.1.1.1, we have

$$U = \frac{1}{2} \{p\}' [K] \{p\} \quad (5-392)$$

where

$$[K] = [F_{11}] - [F_{12}] [F_{22}]^{-1} [F_{21}] \quad (5-393)$$

This could be used to calculate an influence matrix for the cantilevered condition. However, a scheme that is one degree-of-freedom more accurate is to set q_{11} and q_{22} equal to zero in Equation 5-390 by the transformation:

$$(5-394)$$

$$\{q\} = \begin{bmatrix} r_{1j} \\ \{0\}' \\ i_{1j} \\ \{0\}' \end{bmatrix} \begin{bmatrix} q_1 \\ q_2 \\ q_{10} \\ q_{11} \\ q_{21} \end{bmatrix} = [S] \{q^*\}$$

and calculate

$$[G] = [S] ([S]' [F] [S])^{-1} [S]' \quad (5-395)$$

Then it can be shown that

$$U = \frac{1}{2} \{P\} [E] \{P\} \quad (5-396)$$

where

$$[E] = [G_{ij}] \quad \begin{array}{l} = \text{influence coefficients for} \\ \text{the beam cantilevered at the} \\ \text{right end} = \text{the upper left,} \\ \text{11 x 11, matrix out of [G].} \end{array} \quad (5-397)$$

5.2.1.3 Inertia Matrix Corresponding to the Direct Stiffness Approach

The kinetic energy, Equation 5-326, can be written as

$$T = \frac{1}{2} \int_0^L m \left(\frac{\partial b_z}{\partial t} \right)^2 dx = \frac{1}{2} \sum_{i=1}^N \int_{x_{i-1}}^{x_i} m \left(\frac{\partial b_z}{\partial t} \right)^2 dx \quad (5-398)$$

We want to show that, according to assumptions already made, the deflection on the i^{th} interval is a cubic curve. This follows from Equation 5-352

$$EI \frac{\partial^4 b_z}{\partial x^4} = M \quad (5-399)$$

and Equation 5-356

$$M = M_i + (x_i - x) V_i \quad (5-400)$$

We then have the following differential equation to integrate:

$$EI \frac{\partial^4 b_z}{\partial x^4} = M_i + (x_i - x) V_i \quad (5-401)$$

If we introduce the non-dimensional variable,

$$s = \frac{x_i - x}{L} \quad (5-402)$$

then

$$EI \frac{1}{L^4} \frac{\partial^4 b_z}{\partial s^4} = M_i + sL V_i \quad (5-403)$$

Contrails

whose solution is obtained by repeated integration:

$$p_z = p_z|_{s=0} + \frac{\partial p_z}{\partial s}|_{s=0} s + \frac{l^2 M_i}{2EI} s^2 + \frac{l^3 Y_i}{6EI} s^3 \quad (5-404)$$

It is more convenient to express this in terms of:

$$p_z|_{s=l} = q_1^{(i)} \quad (5-405)$$

$$-\frac{1}{l} \frac{\partial p_z}{\partial s}|_{s=l} = q_2^{(i)} \quad (5-406)$$

$$p_z|_{s=0} = q_3^{(i)} \quad (5-407)$$

$$-\frac{1}{l} \frac{\partial p_z}{\partial s}|_{s=0} = q_4^{(i)} \quad (5-408)$$

which gives, from Equation 5-404,

$$p_z = q_1^{(i)} + s q_2^{(i)} - s^2 (3 q_1^{(i)} + 2l q_2^{(i)} - 3 q_3^{(i)} + l q_4^{(i)}) + s^3 (2 q_1^{(i)} + l q_2^{(i)} - 2 q_3^{(i)} + l q_4^{(i)})$$

$$= \begin{bmatrix} 1 & s & s^2 & s^3 \end{bmatrix} \begin{bmatrix} 1 & 0 & 0 & 0 \\ 0 & 1 & 0 & 0 \\ -3 & -2l & 3 & -l \\ 2 & l & -2 & l \end{bmatrix} \begin{bmatrix} q_1 \\ q_2 \\ q_3 \\ q_4 \end{bmatrix} \quad (5-409)$$

Now, the kinetic energy can be written as

$$T = \frac{1}{2} \sum_{i=1}^N \int_0^l m \left(\frac{\partial p_z}{\partial t} \right)^2 ds \quad (5-410)$$

and, on the i^{th} interval,

$$\left(\frac{\partial p_z}{\partial t} \right)^2 = \begin{bmatrix} 1 & 0 & -3 & 2 \\ 0 & 1 & -2l & l \\ 0 & 3 & -2 & -l \\ 0 & 2 & -l & l \end{bmatrix} \begin{bmatrix} \dot{q}_1 \\ \dot{q}_2 \\ \dot{q}_3 \\ \dot{q}_4 \end{bmatrix} \begin{bmatrix} 1 & s & s^2 & s^3 \end{bmatrix} \begin{bmatrix} 1 & 0 & 0 & 0 \\ 0 & 1 & 0 & 0 \\ -3 & -2l & 3 & -l \\ 2 & l & -2 & l \end{bmatrix} \begin{bmatrix} q_1 \\ q_2 \\ q_3 \\ q_4 \end{bmatrix} \quad (5-411)$$

Contrails

Substitution into Equation 5-410 gives

$$T = \sum_{i=1}^N \dot{q}_i^T [M]_i \dot{q}_i \quad (5-412)$$

where

$$\begin{aligned}
 [M]_i &= \begin{bmatrix} 1 & 0 & 3 & 2 \\ 0 & 1 & 2l & l \\ 0 & 0 & 3 & -2 \\ 0 & 0 & -l & l \end{bmatrix} \int_0^l m ds \begin{bmatrix} s^2 & s^3 & s^4 & s^5 \\ s^3 & s^4 & s^5 & s^6 \\ s^4 & s^5 & s^6 & s^7 \\ s^5 & s^6 & s^7 & s^8 \end{bmatrix} \begin{bmatrix} 1 & 0 & 0 & 0 \\ 0 & 1 & 0 & 0 \\ -3 & 2l & 3 & -l \\ 2 & l & -2 & l \end{bmatrix} \\
 &= ml \begin{bmatrix} 1 & 0 & 3 & 2 \\ 0 & 1 & 2l & l \\ 0 & 0 & 3 & -2 \\ 0 & 0 & -l & l \end{bmatrix} \begin{bmatrix} \frac{1}{2} & \frac{1}{3} & \frac{1}{4} & \frac{1}{5} \\ \frac{1}{3} & \frac{1}{4} & \frac{1}{5} & \frac{1}{6} \\ \frac{1}{4} & \frac{1}{5} & \frac{1}{6} & \frac{1}{7} \\ \frac{1}{5} & \frac{1}{6} & \frac{1}{7} & \frac{1}{8} \end{bmatrix} \begin{bmatrix} 1 & 0 & 0 & 0 \\ 0 & 1 & 0 & 0 \\ -3 & 2l & 3 & -l \\ 2 & l & -2 & l \end{bmatrix} \\
 &= ml \begin{bmatrix} 0.37143 & 0.05238 & 0.12857l & -0.03095l \\ 0.05238 & 0.00952 & 0.03095 & -0.00714 \\ 0.12857 & 0.03095 & 0.37143 & -0.05238l \\ -0.03095l & -0.00714l & -0.05238l & 0.00952l^2 \end{bmatrix}
 \end{aligned} \quad (5-413)$$

Now, from Equation 5-306,

$$\{q\}_i = [T]_i \{q\} \quad (5-414)$$

and

$$\{q\} = \begin{bmatrix} r_1 \\ -[F_{22}]^{-1}[F_{21}] \end{bmatrix} \{p\} = [TK] \{p\} \quad (5-415)$$

and hence

$$T = \frac{1}{2} \{p\}^T [AK] \{p\} \quad (5-416)$$

where

$$[A] = \sum_{i=1}^{10} [T]' [T]_i' [M]_i [T]_i [T] \quad (5-417)$$

5.2.1.4 Influence Coefficients by the Complementary Energy Method

From Equation 5-359, we have

$$u_i = \frac{1}{2} \{L\}'_i [G]_i \{L\}_i \quad (5-418)$$

where

$$[G]_i = \begin{bmatrix} \frac{l^3}{3EI} & \frac{l^2}{2EI} \\ \frac{l^2}{2EI} & \frac{l}{EI} \end{bmatrix} \quad (5-419)$$

Now, consider the equilibrium of the free-body in Figure 99.

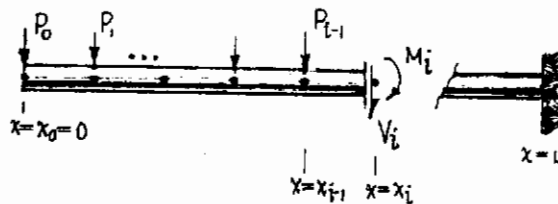

FIGURE 99 LOADS ON THE PORTION OF THE BEAM TO THE LEFT OF $x = x_i$

From equilibrium, we have

$$V_i = -P_0 - P_1 - \dots - P_{i-1} = \{-1, -1, \dots, -1, 0, \dots, 0\} \{P\} \quad (5-420)$$

Contrails

$$\begin{aligned}
 M_i &= (x_i - x_0) P_0 + (x_i - x_1) P_1 + \dots + (x_i - x_{i-1}) P_{i-1} \\
 &= [x_i - x_0, x_i - x_1, \dots, x_i - x_{i-1}, 0 \dots 0] \{P\} \\
 &= [(i)l, (i-1)l, \dots, 2l, l, 0 \dots 0] \{P\}
 \end{aligned}
 \tag{5-421}$$

We may write these equations as:

$$\{L\}_i = [C]_i \{P\}
 \tag{5-422}$$

where

$$[C]_i = \begin{bmatrix} -1, & -1, & \dots, & -1, & -1, & 0 \dots 0 \\ (i)l, & (i-1)l, & \dots, & 2l, & l, & 0 \dots 0 \end{bmatrix}
 \tag{5-423}$$

|
ith column

Substitution of Equation 5-422 into Equation 5-418 gives

$$U = \sum_i P_i^T [E]_i \{P\}
 \tag{5-424}$$

where

$$[E] = \sum_{i=1}^n [C]_i^T [G]_i [C]_i
 \tag{5-425}$$

5.2.1.5 Inertia Matrix by Trapezoidal Interpolation

This method has already been considered in Paragraph 5.1.2.2, where it has been shown that

$$[A] = \sum_{i=1}^N [T]_i^T [A]_i [T]_i
 \tag{5-426}$$

where, for the present case (see Equation 5-225),

$$[A]_i = ml \begin{bmatrix} \frac{1}{2} & \frac{1}{6} \\ \frac{1}{6} & \frac{1}{2} \end{bmatrix} \quad (5-427)$$

and

$$[\tau]_i = \begin{bmatrix} 0, 0 \dots 1, 0, 0 \dots 0 \\ 0, 0 \dots 0, 1, 0 \dots 0 \end{bmatrix} \quad (5-428)$$

5.2.1.6 Comparison and Conclusions

Table 10 summarizes the numerical results of this section.

The comparison of the complementary energy method with the direct stiffness method bears out the fact that they are equivalent methods that use the same mathematical model and the same approximations.

The diparabolic method gives very good results when it is considered that the system is allowed only half as many degrees-of-freedom as for the other cases. When the complementary energy or direct stiffness influence coefficients are used, the results can be improved considerably by using a diparabolic inertia matrix instead of a trapezoidal inertia matrix.

Finally, the direct stiffness method has the distinct advantage that an inertia matrix can be derived consistent with the internal load paths of the structure and the use of this matrix gives modes and frequencies very nearly equal to the exact solution for the continuous structure.

5.2.2 Vibration of Thin-Wall Cylinders

This section deals with thin-wall, large diameter cylindrical structures that are typical of liquid propellant tanks on current clustered launch vehicles. Fairly slender thin-wall cylinders also find applications as heat shields and payload fairings on both liquid and solid propellant launch vehicles.

Paragraph 5.2.2.1, below, contains some important deviations from the Euler-Bernoulli theory of beams, and comparisons between methods for including the various effects of shear energy and rotary inertia are shown.

Paragraph 5.2.2.2 contains analyses concerned with shorter cylinders where the structure must be considered as a thin shell. The effects of internal pressure and axial loads are considered in the shell study.

Finally, Paragraph 5.2.2.3 deals again with a beam model; however, in this case, the results are derived from shell theory, and thus the important effects of internal pressure are retained.

METHOD*	NONDIMENSIONAL FREQUENCY, $\omega_1^2 \frac{mL^4}{EI}$							
	FREE-FREE				CANTILEVERED			
	(1)	(2)	(3)	(4)	(1)	(2)	(3)	(4)
1	500.42	3,803.19	14,616.8	39,960	12.355	485.32	3,806.9	14,619
2	501.05	3,830.30	14,986.0	42,424	12.363	485.97	3,833.1	14,980
3	517.66	4,246.77	17,819.1	52,958	12.526	524.84	4,454.6	18,593
4	510.64	4,094.04	17,059.9	51,756	12.344	496.12	4,096.3	17,060
5	500.63	3,807.49	14,677.4	40,389	12.362	485.57	3,809.2	14,655
6	510.64	4,094.01	17,060.8	51,745	12.344	496.12	4,096.3	17,060

- * 1 Exact Solution
- 2 Mass Matrix - Diparabolic
Influence Matrix - Complementary Energy
- 3 Mass Matrix - Diparabolic
Influence Matrix - Diparabolic
- 4 Mass Matrix - Trapezoidal
Influence Matrix - Complementary Energy
- 5 Mass Matrix - Direct Stiffness
Influence Matrix - Direct Stiffness
- 6 Mass Matrix - Trapezoidal
Influence Matrix - Direct Stiffness

TABLE 10
A COMPARISON OF SEVERAL METHODS TO OBTAIN THE FREQUENCIES OF A STRAIGHT BEAM

5.2.2.1 A Study of Vibration Modes of Straight Beams with Thin-Wall Cylindrical Cross Sections

In this section, a number of analyses are compared to evaluate the various effects of shear strain energy and rotary inertia. All of the numerical comparisons are given for a cantilevered thin-wall cylinder idealized as a beam. The geometry is shown in Figure 100.

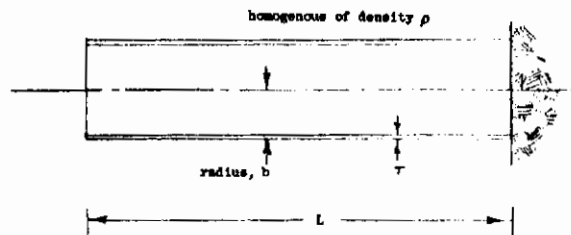

FIGURE 100 GEOMETRY OF THE STRUCTURE

The equivalent beam section properties are taken to be:

$$EI = E\pi b^3 \tau \quad (5-429)$$

$$GA = \frac{E}{2(1+\nu)} \pi b \tau \quad (\text{see Paragraph 5.1.1.3.1.3, Equation 5-170}) \quad (5-430)$$

$$m = 2\pi b \tau \rho \quad (5-431)$$

$$I = \text{moment of inertia/unit length} = \pi b^3 \tau \rho \quad (5-432)$$

The numerical analysis is given for a beam that is an idealization of the outer liquid oxygen tanks on the fifth-scale model of the Saturn launch vehicle (see Appendix II).

The values of the beam parameters in this case are:

$$L = 105.91 \text{ inches}$$

$$b = 7.0135 \text{ inches}$$

$$\tau = 0.020 \text{ inches}$$

$$\rho = 0.1 \text{ lbm/in}^3$$

$$E = 10.6 \times 10^6 \text{ lbF/in}^2 \quad (\text{Aluminum})$$

$$\nu = 0.3$$

5.2.2.1.1 Equations for a Beam Including Shear Energy and Rotary Inertia

The most general beam representation of this particular type of structure has a kinetic energy and strain energy given by the following expressions:

$$T = \frac{1}{2} \int_0^L \left(m \left(\frac{\partial \zeta}{\partial t} \right)^2 + I \left(\frac{\partial \theta}{\partial t} \right)^2 \right) dx \quad (5-433)$$

$$U = \frac{1}{2} \int_0^L \left(\frac{M^2}{EI} + \frac{V^2}{GA} \right) dx \quad (5-434)$$

where $\theta(x,t)$ is the rotation of a section and $\zeta(x,t)$ is the deflection of the axis.

It is assumed that

$$\theta(x,t) \neq \frac{\partial \zeta}{\partial x}(x,t) \quad (5-435)$$

that is, sections do not rotate so that they remain perpendicular to the elastic deflection curve. The above expressions define what is commonly called Timoshenko's theory of beams. The partial differential equations for the continuous beam can be obtained, as in Paragraph 5.2.1.1, by using Hamilton's Principle.

$$\delta \int_{t_1}^{t_2} (T - U) dt = 0 \quad (5-436)$$

It can be shown that the stress resultants are related to the beam deformation functions by

$$V = GA \left(\frac{\partial \zeta}{\partial x} - \theta \right) \quad (5-437)$$

$$M = -EI \frac{\partial \theta}{\partial x} \quad (5-438)$$

so that

$$T - U = \int_0^L \left(m \left(\frac{\partial \zeta}{\partial t} \right)^2 + I \left(\frac{\partial \theta}{\partial t} \right)^2 - EI \left(\frac{\partial \theta}{\partial x} \right)^2 - GA \left(\frac{\partial \zeta}{\partial x} - \theta \right)^2 \right) dx \quad (5-439)$$

Contrails

and the variational problem gives:

$$EI \frac{\partial^2 \theta}{\partial x^2} + GA \left(\frac{\partial \zeta}{\partial x} - \theta \right) - I \frac{\partial^2 \theta}{\partial t^2} = 0 \quad (5-440)$$

$$m \frac{\partial^2 \zeta}{\partial t^2} - GA \left(\frac{\partial \zeta}{\partial x^2} - \frac{\partial \theta}{\partial x} \right) = 0 \quad (5-441)$$

which are the "Timoshenko-Beam" equations¹. The "Euler-Bernoulli" equations are obtained by using the first equation to eliminate $\frac{\partial \zeta}{\partial x} - \theta$ in the second equation and then setting

$$\theta = \frac{\partial \zeta}{\partial x} \quad (5-442)$$

The numerical results of this section are concerned with the following special cases of Equations 5-433 and 5-434:

- (1) Complete Timoshenko Beam analysis for 50 degrees-of-freedom
- (2) Shear energy and rotary inertia included but rotary inertia described in terms of lateral displacements by use of

$$\theta = \frac{\partial \zeta}{\partial x}$$

- for 25 degrees-of-freedom
- (3) Shear energy included but no rotary inertia for 25 degrees-of-freedom, $I = 0$
- (4) No shear energy and no rotary inertia (Euler-Bernoulli theory) for 25 degrees-of-freedom

$$\theta = \frac{\partial \zeta}{\partial x} \quad \text{in shear energy term and} \\ I = 0$$

In the numerical studies the beam was divided into 24 equally spaced intervals by 25 collocation points, and the generalized coordinates were taken to be the displacement and rotation at each of the collocation points.

$$\begin{matrix} 50 \times 1 \\ \{p\} = \end{matrix} \begin{bmatrix} \zeta_1 \\ \zeta_1 \\ \vdots \\ \zeta_{25} \\ \theta_1 \\ \theta_2 \\ \vdots \\ \theta_{25} \end{bmatrix} \quad (5-443)$$

where $\zeta_i = \zeta(x_i, t)$
 $\theta_i = \theta(x_i, t)$

¹For a more complete discussion of these equations for the continuous case, reference should be made to Huang, T. C., The Effect of Rotary Inertia and of Shear Deformation on the Frequency and Normal Mode Equations of a Uniform Beam with Simple End Conditions, Journal of Applied Mechanics, Dec. 1961.

The generalized forces associated with these generalized coordinates are

(5-444)

$$\{P\} = \begin{bmatrix} Z_1 \\ Z_2 \\ \vdots \\ Z_{25} \\ \theta_1 \\ \theta_2 \\ \vdots \\ \theta_{25} \end{bmatrix}$$

where Z_i is the load at the i^{th} collocation point

and θ_i is the moment at the i^{th} collocation point

5.2.2.1.1.1 Timoshenko Beam

The complementary energy method (see Paragraph 5.1.1.3.2, Equation 5-183), including shear energy, gives the following for the influence coefficients corresponding to these degrees-of-freedom:

$$U_i = \frac{1}{2} \{V_i \ M_i\} \begin{bmatrix} \frac{\ell^3}{3EI} + \frac{\ell}{GA} & \frac{\ell^2}{2EI} \\ \frac{\ell^2}{2EI} & \frac{\ell}{EI} \end{bmatrix} \begin{bmatrix} V_i \\ M_i \end{bmatrix} \quad (5-445)$$

and Equation 5-422 of Paragraph 5.2.1.4 is modified to give

$$\begin{bmatrix} V_i \\ M_i \end{bmatrix} = [C]_i \{P\} \quad (5-446)$$

where

$$[C]_i = \begin{bmatrix} -1, & -1, & \dots, & -1, & -1, & 0, \dots, 0 & | & 0, & 0, & \dots, & 0, & 0, \dots, 0 \\ (\omega\ell, & (\omega\ell), & \dots, & 2\ell, & \ell, & 0, \dots, 0 & | & 1, & 1, & \dots, & 1, & 0, \dots, 0 \end{bmatrix} \quad (5-447)$$

The influence coefficients for the Timoshenko beam are then defined by

$$U = \frac{1}{2} \{P\}' [E] \{P\} \quad (5-448)$$

Contrails

where

$$[E] = \sum_{i=1}^{24} [C]_i' [G]_i [C]_i \quad (5-449)$$

If we partition this into 25 x 25 square matrices:

$$[E] = \begin{bmatrix} [E_{zz}] & [E_{z\theta}] \\ [E_{\theta z}] & [E_{\theta\theta}] \end{bmatrix} \quad (5-450)$$

then, from Castigliano's theorem, we have

$$\{z\} = [E_{zz}] \{z\} + [E_{z\theta}] \{\theta\} \quad (5-451)$$

$$\{\theta\} = [E_{\theta z}] \{z\} + [E_{\theta\theta}] \{\theta\} \quad (5-452)$$

which are useful for interpretation of the results of this section.

For the inertia matrix, diparabolic interpolation gives

$$\frac{\partial z}{\partial t} = \{1 \ z \ z^2 \ z^3\} [z]_i [T]_i \{\dot{z}\} \quad (5-453)$$

$$\frac{\partial \theta}{\partial t} = \{1 \ \theta \ \theta^2 \ \theta^3\} [\theta]_i [T]_i \{\dot{\theta}\} \quad (5-454)$$

and substitution into Equation 5-433 gives

$$T = \frac{1}{2} \{\dot{z}\}' \sum_{i=1}^{24} [T]_i' [z]_i' \begin{bmatrix} 1 & z & z^2 & z^3 \\ z & z^2 & z^3 & z^4 \\ z^2 & z^3 & z^4 & z^5 \\ z^3 & z^4 & z^5 & z^6 \\ z^4 & z^5 & z^6 & z^7 \end{bmatrix} [z]_i [T]_i \{\dot{z}\} m \quad (5-455)$$

$$\frac{1}{2} I \{\dot{\theta}\}' \sum_{i=1}^{24} [T]_i' [\theta]_i' \begin{bmatrix} 1 & \theta & \theta^2 & \theta^3 \\ \theta & \theta^2 & \theta^3 & \theta^4 \\ \theta^2 & \theta^3 & \theta^4 & \theta^5 \\ \theta^3 & \theta^4 & \theta^5 & \theta^6 \\ \theta^4 & \theta^5 & \theta^6 & \theta^7 \end{bmatrix} [\theta]_i [T]_i \{\dot{\theta}\}$$

Contrails

or

$$\tau = \frac{1}{2} \{ \dot{\beta} \}' [A] \{ \dot{\beta} \} \quad (5-456)$$

where

$$[A] = \begin{bmatrix} 2\pi b \tau_0 [\bar{A}] & [0] \\ [0] & 2\pi b^2 \tau [\bar{A}] \end{bmatrix} \quad (5-457)$$

with

$$[\bar{A}] = \sum_{i=1}^{24} [\tau]_i' [\beta]_i' \begin{bmatrix} 1 & \frac{1}{2} & \frac{1}{4} & \frac{1}{8} \\ \frac{1}{2} & \frac{1}{4} & \frac{1}{8} & \frac{1}{16} \\ \frac{1}{4} & \frac{1}{8} & \frac{1}{16} & \frac{1}{32} \\ \frac{1}{8} & \frac{1}{16} & \frac{1}{32} & \frac{1}{64} \end{bmatrix} [\beta]_i [\tau]_i \quad (5-458)$$

The modes and frequencies for the Timoshenko beam are obtained from

$$[E][A] \{ \varphi \} = \lambda \{ \varphi \} \quad (5-459)$$

5.2.2.1.1.2 Shear Energy Uncoupled from Rotary Inertia

In the second case Equation 5-442 was used to give

$$\theta_i = \frac{\partial \xi}{\partial x} (x_i, t) \quad (5-460)$$

This, in conjunction with the diparabolic formula, gives

$$\theta_i = \frac{1}{2} \{ 0 \ 1 \ 2\xi \ 3\xi^2 \} [\beta]_i \begin{bmatrix} \beta_{i-1} \\ \beta_i \\ \beta_{i+1} \\ \beta_{i+2} \end{bmatrix}$$

at $\xi = 0$

Contrails

which yields

$$\theta_1 = \frac{1}{2} \left\{ -\frac{5}{4} \quad \frac{3}{2} \quad -\frac{1}{4} \right\} \begin{bmatrix} \dot{y}_1 \\ \dot{y}_2 \\ \dot{y}_3 \end{bmatrix} \quad (5-461)$$

$$\theta_2 = \frac{1}{2} \left\{ -\frac{1}{2} \quad 0 \quad \frac{1}{2} \quad 0 \right\} \begin{bmatrix} \dot{y}_{i-1} \\ \dot{y}_i \\ \dot{y}_{i+1} \\ \dot{y}_{i+2} \end{bmatrix} \quad (5-462)$$

$$\theta_{25} = \frac{1}{4} \left\{ \frac{1}{4} \quad -\frac{3}{2} \quad \frac{5}{4} \right\} \begin{bmatrix} \dot{y}_{23} \\ \dot{y}_{24} \\ \dot{y}_{25} \end{bmatrix} \quad (5-463)$$

These equations may be combined to give the following transformation

$$\{\theta\} = [\Delta] \{\dot{y}\} \quad (5-464)$$

Substituting this into the kinetic energy gives

$$T = \frac{1}{2} \{\dot{y}\}' (2\pi b^2 \rho [\bar{A}]) \{\dot{y}\} + \frac{1}{2} \{\dot{y}\}' [\Delta]' (\rho \pi b^2 \rho [\bar{A}]) [\Delta] \{\dot{y}\} \quad (5-465)$$

or

$$T = \frac{1}{2} \{\dot{y}\}' \{ [A_{00}] + [\Delta]' [A_{00}] [\Delta] \} \{\dot{y}\} \quad (5-466)$$

where

$$[A_{00}] = 2\pi b^2 \rho [\bar{A}] \quad (5-467)$$

and

$$[A_{00}] = \rho \pi b^2 \rho [\bar{A}] \quad (5-468)$$

The second term gives the rotary inertia contribution in terms of lateral velocities. The influence coefficients for case (2) are obtained by setting $\theta_i = 0$ which gives

$$[E_{IJ}]$$

in Equation 5-450.

The modes and frequencies for the second case are obtained by iterating

$$[E_{IJ}][A_{IJ}] + [\Delta][A_{\theta\theta}][\Delta]\{\varphi\} = \lambda\{\varphi\} \quad (5-469)$$

5.2.2.1.1.3 Shear Energy with No Rotary Inertia

For case (3) the influence coefficients are the same as for case (2) and the mass matrix is $[A_{IJ}]$. The modes and frequencies are obtained from

$$[E_{IJ}][A_{IJ}]\{\varphi\} = \lambda\{\varphi\} \quad (5-470)$$

5.2.2.1.1.4 Euler-Bernoulli Beam

For case (4) the inertia matrix is the same as case (3) and the influence matrix is computed by using

$$[G]_i = \begin{bmatrix} \frac{I^3}{3EI} & \frac{I^2}{2EI} \\ \frac{I^2}{2EI} & \frac{I}{EI} \end{bmatrix} \quad (5-471)$$

That is, with $1/GA = 0$.

5.2.2.1.2 Comparison and Conclusions

The results of the study are summarized in Table 11, where the first ten natural frequencies for the four cases are given.

Figure 101 is a plot of the second and third modes showing a comparison of cases (1), (3), and (4) indicating the important contribution of shear deflections for thin-wall cylinders.

The following conclusions are drawn from this study:

- (1) For the lower frequency range of structural vibrations, the Timoshenko theory is more sophisticated than is required, and the important results are obtained if only shear energy is included (this result is well known and has, in fact, been established by Timoshenko). The consequence of this, for the finite degree-of-freedom methods, is a saving of one-half the number of degrees-of-freedom and resulting matrices only one-half as large.

Conclusions

- (2) Attempts to include rotary inertia by assuming that the section rotates normal to the elastic curve is detrimental to the results and is generally inconsistent with the fact that shear energy is stored in the beam.
- (3) The results of this section suggest that a more consistent approximation to the Timoshenko beam is to set the applied moments, $\{\theta\}$, to zero and use Equations 5-451 and 5-452 to obtain

$$\{s\} = [E_{rr}]\{z\} \quad (5-472)$$

$$\{\theta\} = [E_{\theta r}]\{z\} \quad (5-473)$$

or

$$\{\theta\} = [E_{\theta r}][E_{rr}]^{-1}\{s\} \quad (5-474)$$

and use method (2) with

$$[\Delta] = [E_{\theta r}][E_{rr}]^{-1} \quad (5-475)$$

When shear energy is neglected, the above expression will be approximately that given by the diparabolic method.

CASE*	FREQUENCY (c.p.s.)									
	1ST MODE	2ND MODE	3RD MODE	4TH MODE	5TH MODE	6TH MODE	7TH MODE	8TH MODE	9TH MODE	10TH MODE
(1)	48.640	264.229	630.379	1045.794	1480.935	1916.491	2345.783	2764.122	3169.884	3541.367
(2)	48.632	263.127	617.507	995.732	1359.437	1691.323	1991.436	2265.697	2522.639	2770.728
(3)	50.045	313.634	878.290	1721.744	2848.573	4261.980	5968.023	7976.032	10299.871	12957.733
(4)	48.772	267.938	642.957	1069.378	1513.423	1955.959	2390.942	2817.016	3235.647	3649.229

- * Case (1) Timoshenko Beam
- Case (2) Shear Energy with Rotary Inertia Expressed in Terms of Lateral Displacements.
- Case (3) No Shear Energy - No Rotary Inertia.
- Case (4) Shear Energy - No Rotary Inertia.

TABLE 11
 FREQUENCIES FOR A CYLINDRICAL, THIN-WALL, STRAIGHT BEAM SHOWING
 THE EFFECTS OF SHEAR ENERGY AND ROTARY INERTIA

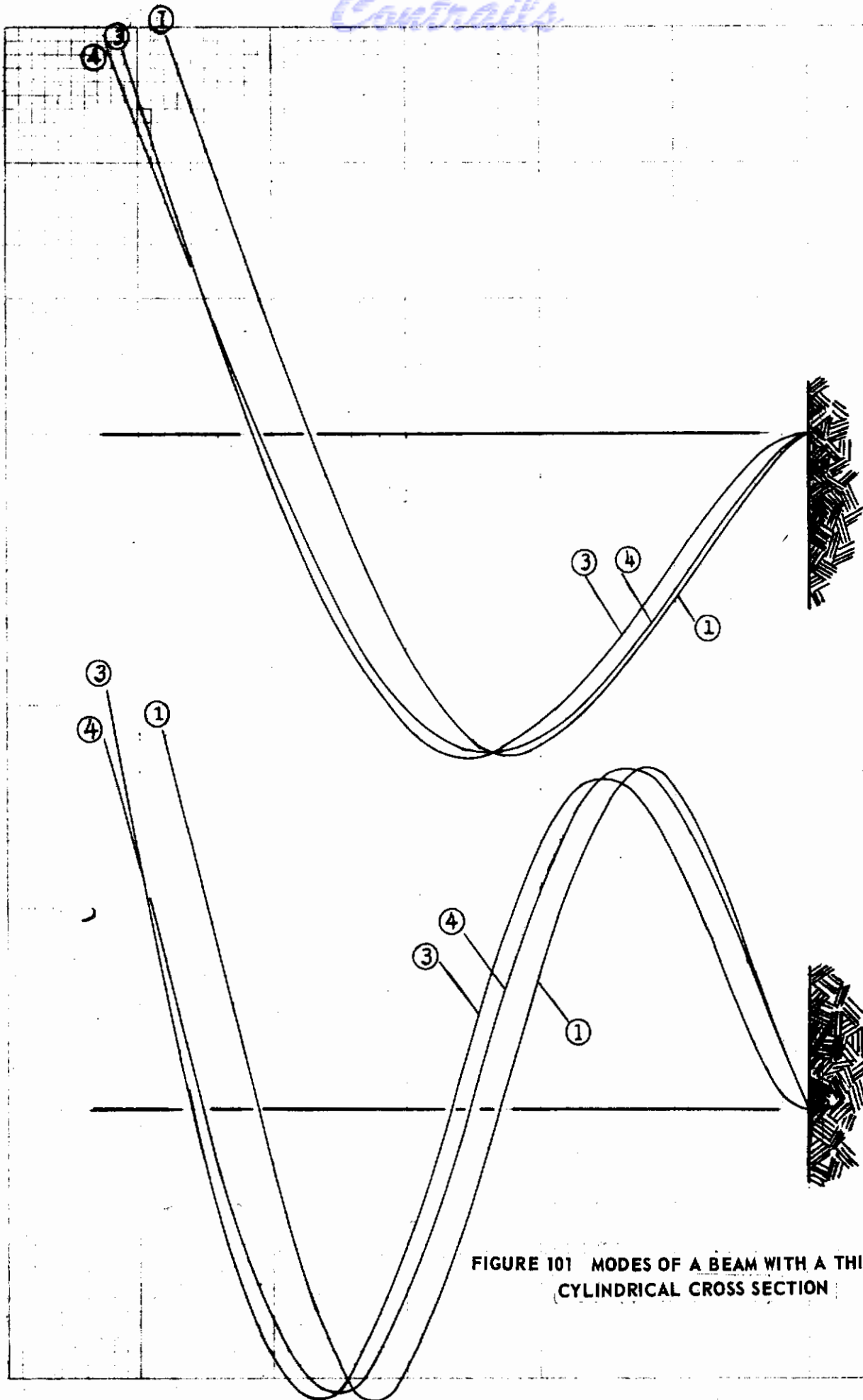

FIGURE 101 MODES OF A BEAM WITH A THIN-WALL. CYLINDRICAL CROSS SECTION

5.2.2.2 Some Considerations of the Vibrations of Axially and Circumferentially Loaded Thin Cylindrical Shells

In this section we consider the analysis of a thin cylindrical shell of length, L , radius, b , and wall thickness, τ . The approach to the problem is similar to that used on the thin ring in Paragraph 2.3.3.3. In that analysis we found it convenient to use cylindrical coordinates which will also prove to be the case for the shell. The geometry of the shell is shown in Figure 102.

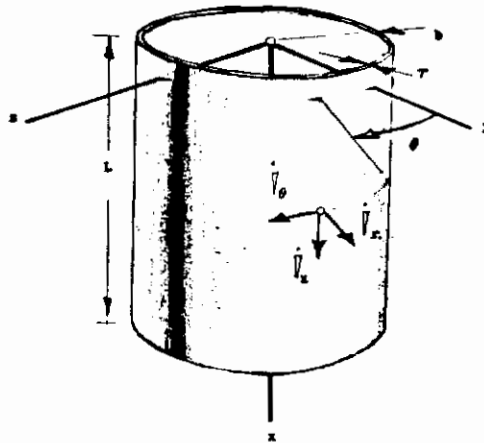

FIGURE 102 THIN CYLINDRICAL SHELL

The difficult part of the analysis is the derivation of an expression for the specific internal energy, $u(r, \theta, x, t)$, in terms of displacements of the shell "mid-surface," $p_r(\theta, x, t)$, $p_\theta(\theta, x, t)$, and $p_x(\theta, x, t)$.

5.2.2.2.1 Strain Energy for a Cylindrical Shell

We assume that the shell is in a state of plane stress with the only nonzero stresses being $\sigma_{\theta\theta}$, σ_{xx} , and $\sigma_{x\theta}$. The specific internal strain energy is then

$$u = \frac{1}{2}(\epsilon_{xx}\sigma_{xx} + \epsilon_{x\theta}\sigma_{x\theta} + \epsilon_{\theta\theta}\sigma_{\theta\theta}) \quad (5-476)$$

and Hooke's law reduces to

$$\sigma_{xx} = \frac{E}{1-\nu^2} (\epsilon_{xx} + \nu\epsilon_{\theta\theta}) \quad (5-477)$$

$$\tau_{x\theta} = \frac{E}{2(1+\nu)} \epsilon_{x\theta} \quad (5-478)$$

$$\sigma_{\theta\theta} = \frac{E}{1-\nu^2} (\epsilon_{\theta\theta} + \nu\epsilon_{xx}) \quad (5-479)$$

Substitution into Equation 5-476 gives the specific internal energy of a particle in terms of the strains

$$u(\theta, x, t) = \frac{E}{2(1-\nu^2)} (\epsilon_{xx}^2 + \epsilon_{\theta\theta}^2 + 2\nu\epsilon_{xx}\epsilon_{\theta\theta} + \frac{1-\nu}{2}\epsilon_{x\theta}^2) \quad (5-480)$$

5.2.2.2.1.1 Strain-Displacement Relations for a Cylindrical Shell

Since the shell surface is described by $r = b$, the coordinates θ and x are coordinates in the surface of the shell, and we then can introduce a position vector for the θ - x particle at time, t .

$$\pi = \pi(\theta, x, t) \quad (5-481)$$

We shall denote the position vector for the θ - x particle when in the undeformed state by

$$L(\theta, x) = x\hat{V}_x + b\hat{V}_\theta \quad (5-482)$$

where \hat{V}_θ , \hat{V}_θ , and \hat{V}_x are a set of cylindrical coordinate unit vectors. The displacement of particles on the shell mid-surface is then given by

$$p(\theta, x, t) = \pi(\theta, x, t) - L(\theta, x) \quad (5-483)$$

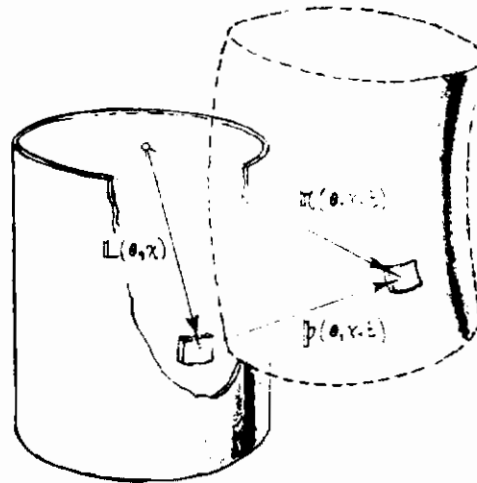

FIGURE 103 SHELL DISPLACEMENTS

If we denote the components of \mathbb{p} in the \dot{V}_θ , \dot{V}_x , and \dot{V}_r directions by p_θ , p_x and p_r , then

$$\mathbb{p}(\theta, x, t) = p_\theta(\theta, x, t)\dot{V}_\theta + p_x(\theta, x, t)\dot{V}_x + p_r(\theta, x, t)\dot{V}_r \quad (5-484)$$

The strains of the mid-surface can be defined by

$$\begin{aligned} d\mathbb{K} \cdot d\mathbb{K} - d\mathbb{L} \cdot d\mathbb{L} \\ = 2 \left(\epsilon_{xx} dx dx + 2\epsilon_{x\theta} b dx d\theta + \epsilon_{\theta\theta} b^2 d\theta d\theta \right) \end{aligned} \quad (5-485)$$

$r = b$

Contrails

The total strains are then assumed to be

$$\epsilon_{xx} = \epsilon_{xx}|_{r=b} - (r-b) \frac{\partial^2 p_r}{\partial x^2} \quad (5-486)$$

$$\epsilon_{x\theta} = \epsilon_{x\theta}|_{r=b} - 2 \frac{(r-b)}{r} \left(\frac{\partial^2 p_r}{\partial x \partial \theta} - \frac{\partial p_\theta}{\partial x} \right) \quad (5-487)$$

$$\epsilon_{\theta\theta} = \epsilon_{\theta\theta}|_{r=b} - \frac{r-b}{r^2} \left(\frac{\partial^2 p_r}{\partial \theta^2} - \frac{\partial p_\theta}{\partial \theta} \right) \quad (5-488)$$

The terms depending on the mid-surface curvatures used here are those proposed by Timoshenko for cylindrical shells in which $r \ll b$. The more general case has been considered by Love.

Now from Equation 5-482,

$$\begin{aligned} dL &= \frac{\partial L}{\partial x} dx + \frac{\partial L}{\partial \theta} d\theta \\ &= \dot{r}_x dx + \dot{r}_\theta d\theta \end{aligned} \quad (5-489)$$

and from Equation 5-483,

$$\begin{aligned} dM &= \left(\frac{\partial M}{\partial x} + \frac{\partial P}{\partial x} \right) dx + \left(\frac{\partial M}{\partial \theta} + \frac{\partial P}{\partial \theta} \right) d\theta \\ &= \left(\dot{r}_x + \frac{\partial P}{\partial x} \right) dx + \left(\dot{r}_\theta + \frac{\partial P}{\partial \theta} \right) d\theta \end{aligned} \quad (5-490)$$

which gives

$$\begin{aligned} dM^2 - dL^2 &= \left(2 \dot{r}_x \cdot \frac{\partial P}{\partial x} + \frac{\partial P}{\partial x} \cdot \frac{\partial P}{\partial x} \right) dx dx \\ &\quad + 2 \left(\dot{r}_x \cdot \frac{\partial P}{\partial \theta} + b \dot{r}_\theta \cdot \frac{\partial P}{\partial x} + \frac{\partial P}{\partial x} \cdot \frac{\partial P}{\partial \theta} \right) dx d\theta \\ &\quad + \left(2b \dot{r}_\theta \cdot \frac{\partial P}{\partial \theta} + \frac{\partial P}{\partial \theta} \cdot \frac{\partial P}{\partial \theta} \right) d\theta d\theta \end{aligned} \quad (5-491)$$

By comparing this with Equation 5-485, we conclude

$$\epsilon_{xx}|_{r=b} = \dot{r}_x \cdot \frac{\partial P}{\partial x} + \frac{1}{2} \frac{\partial P}{\partial x} \cdot \frac{\partial P}{\partial x} \quad (5-492)$$

$$\epsilon_{x\theta}|_{r=b} = \frac{1}{2b} \left(\dot{r}_x \cdot \frac{\partial P}{\partial \theta} + b \dot{r}_\theta \cdot \frac{\partial P}{\partial x} + \frac{\partial P}{\partial x} \cdot \frac{\partial P}{\partial \theta} \right) \quad (5-493)$$

Contrails

$$\epsilon_{\theta\theta}|_{r=r_0} = \frac{1}{b^2} \left(b \dot{p}_0 \cdot \frac{\partial \dot{p}}{\partial \theta} + \frac{1}{2} \frac{\partial \dot{p}}{\partial \theta} \cdot \frac{\partial \dot{p}}{\partial \theta} \right) \quad (5-494)$$

Using Equation 5-484 together with Equations 5-486, 5-487, and 5-488, results in the final equations for the strains in terms of displacements

$$\epsilon_{xx} = \frac{\partial p_x}{\partial x} + \frac{1}{2} \left(\frac{\partial p_x}{\partial x} \right)^2 + \frac{1}{2} \left(\frac{\partial p_\theta}{\partial x} \right)^2 + \frac{1}{2} \left(\frac{\partial p_r}{\partial x} \right)^2 - (n-6) \frac{\partial^2 p_r}{\partial x^2} \quad (5-495)$$

$$\epsilon_{x\theta} = \frac{1}{2b} \frac{\partial p_x}{\partial \theta} + \frac{1}{2} \frac{\partial p_\theta}{\partial x} + \frac{1}{2b} \frac{\partial p_x}{\partial x} \left(\frac{\partial p_r}{\partial \theta} - p_\theta \right) - \frac{2(n-6)}{b} \frac{\partial^2 p_r}{\partial x \partial \theta} - \frac{\partial p_\theta}{\partial x} \quad (5-496)$$

$$\epsilon_{\theta\theta} = \frac{1}{b} \left(\frac{\partial p_\theta}{\partial \theta} + p_r \right) + \frac{1}{2b^2} \left(\frac{\partial p_\theta}{\partial \theta} \right)^2 + \frac{1}{2b^2} \left(\frac{\partial p_r}{\partial \theta} - p_\theta \right)^2 - \frac{4(n-6)}{b^2} \frac{\partial^2 p_r}{\partial \theta^2} - \frac{\partial p_\theta}{\partial \theta} \quad (5-497)$$

5.2.2.2.1.2 The Total Strain Energy Including Nonlinear Terms in the Strain-Displacement Relations

In order to simplify the operations, we introduce the following notation for the nonlinear part of the strains

$$\Delta_{xx} = \frac{1}{2} \frac{\partial p}{\partial x} \cdot \frac{\partial p}{\partial x} = \frac{1}{2} \left(\frac{\partial p_x}{\partial x} \right)^2 + \frac{1}{2} \left(\frac{\partial p_\theta}{\partial x} \right)^2 + \frac{1}{2} \left(\frac{\partial p_r}{\partial x} \right)^2 \quad (5-498)$$

$$\Delta_{x\theta} = \frac{1}{2b} \frac{\partial p}{\partial x} \cdot \frac{\partial p}{\partial \theta} = \frac{1}{2b} \frac{\partial p_x}{\partial x} \left(\frac{\partial p_r}{\partial \theta} - p_\theta \right) + \frac{1}{2b} \frac{\partial p_\theta}{\partial x} \left(\frac{\partial p_\theta}{\partial \theta} + p_r \right) + \frac{1}{2b} \frac{\partial p_x}{\partial x} \frac{\partial p_r}{\partial \theta} \quad (5-499)$$

$$\Delta_{\theta\theta} = \frac{1}{2b^2} \frac{\partial p}{\partial \theta} \cdot \frac{\partial p}{\partial \theta} = \frac{1}{2b^2} \left(\frac{\partial p_\theta}{\partial \theta} - p_\theta \right)^2 + \frac{1}{2b^2} \left(\frac{\partial p_r}{\partial \theta} + p_r \right)^2 + \frac{1}{2b^2} \left(\frac{\partial p_r}{\partial \theta} \right)^2 \quad (5-500)$$

Equations 5-495, 5-496, and 5-497 can then be written as

$$\epsilon_{xx} = \frac{\partial p_x}{\partial x} + \Delta_{xx} - (n-6) \frac{\partial^2 p_r}{\partial x^2} \quad (5-501)$$

$$\epsilon_{x\theta} = \frac{1}{2b} \frac{\partial p_x}{\partial \theta} + \frac{1}{2} \frac{\partial p_\theta}{\partial x} + \Delta_{x\theta} - \frac{2(n-6)}{b} \left(\frac{\partial^2 p_r}{\partial x \partial \theta} - \frac{\partial p_\theta}{\partial x} \right) \quad (5-502)$$

$$\epsilon_{\theta\theta} = \frac{1}{b} \left(\frac{\partial p_\theta}{\partial \theta} + p_r \right) + \Delta_{\theta\theta} - \frac{(n-6)}{b^2} \left(\frac{\partial^2 p_r}{\partial \theta^2} - \frac{\partial p_\theta}{\partial \theta} \right) \quad (5-503)$$

Now, the total strain energy is

$$\begin{aligned}
 U &= \int u dV & (5-504) \\
 &= \int_0^L \int_0^{2\pi} \int_{b-\frac{t}{2}}^{b+\frac{t}{2}} \frac{E}{2(1-\nu^2)} (\epsilon_{xx}^2 + \epsilon_{\theta\theta}^2 + 2\nu\epsilon_{xx}\epsilon_{\theta\theta} \\
 &\quad + \frac{1-\nu}{2}\epsilon_{x\theta}^2) b dr d\theta dx
 \end{aligned}$$

When Equations 5-501, 5-502, and 5-503 are substituted into this expression, the integration with respect to r can be made explicitly. The result is

(5-505)

$$\begin{aligned}
 U &= \frac{1}{2} \int_0^L \int_0^{2\pi} \frac{E t}{(1-\nu^2)} \left(\left(\frac{\partial p_x}{\partial x} \right)^2 + \frac{1}{b^2} \left(\frac{\partial p_\theta}{\partial \theta} + p_r \right)^2 \right. \\
 &\quad \left. + 2\nu \frac{\partial p_x}{\partial x} \left(\frac{1}{b} \frac{\partial p_\theta}{\partial \theta} + \frac{1}{b} p_r \right) \right. \\
 &\quad \left. + \frac{1-\nu}{2} \left(\frac{1}{2} \frac{\partial p_\theta}{\partial x} + \frac{1}{2b} \frac{\partial p_x}{\partial \theta} \right)^2 \right) b d\theta dx \\
 &+ \frac{1}{2} \int_0^L \int_0^{2\pi} \frac{E t^3}{12(1-\nu^2)} \left(\left(\frac{\partial^2 p_x}{\partial x^2} \right)^2 + \frac{1}{b^4} \left(\frac{\partial^2 p_r}{\partial \theta^2} - \frac{\partial p_\theta}{\partial \theta} \right)^2 \right. \\
 &\quad \left. + 2\nu \frac{1}{b^2} \frac{\partial^2 p_x}{\partial x^2} \left(\frac{\partial^2 p_r}{\partial \theta^2} - \frac{\partial p_\theta}{\partial \theta} \right) \right. \\
 &\quad \left. + \frac{1-\nu}{2} \frac{1}{b^2} \left(\frac{\partial^2 p_x}{\partial x \partial \theta} - \frac{\partial p_\theta}{\partial x} \right)^2 \right) b d\theta dx \\
 &+ \frac{1}{2} \int_0^L \int_0^{2\pi} \frac{2E t}{1-\nu^2} \left(\frac{\partial p_x}{\partial x} \Delta_{xx} + \left(\frac{1}{b} \frac{\partial p_\theta}{\partial \theta} + \frac{1}{b} p_r \right) \Delta_{\theta\theta} \right. \\
 &\quad \left. + \nu \left(\frac{1}{b} \frac{\partial p_\theta}{\partial \theta} + \frac{1}{b} p_r \right) \Delta_{xx} + \nu \frac{\partial p_x}{\partial x} \Delta_{\theta\theta} \right. \\
 &\quad \left. + \frac{1-\nu}{2} \left(\frac{1}{2} \frac{\partial p_\theta}{\partial x} + \frac{1}{2b} \frac{\partial p_x}{\partial \theta} \right) \Delta_{x\theta} \right) b d\theta dx
 \end{aligned}$$

where we have neglected terms of the second order in the Δ 's. In the above expression, the first integral is the energy due to stretching of the mid-surface, the "membrane" energy. The second integral is the bending energy, and the last integral is the nonlinear part of the membrane energy.

Let us consider the stress resultants:

Contrails

$$N_{xx} = \int_{b-\frac{t}{2}}^{b+\frac{t}{2}} \sigma_{xx} dr \quad (5-506)$$

$$N_{x\theta} = \int_{b-\frac{t}{2}}^{b+\frac{t}{2}} \sigma_{x\theta} dr \quad (5-507)$$

$$N_{\theta\theta} = \int_{b-\frac{t}{2}}^{b+\frac{t}{2}} \sigma_{\theta\theta} dr \quad (5-508)$$

Then, from Hooke's law, we obtain

$$N_{xx} = \frac{E\tau}{1-\nu^2} (\epsilon_{xx} + \nu\epsilon_{\theta\theta})_{r=b} \quad (5-509)$$

$$N_{x\theta} = \frac{E}{2(1+\nu)} (\epsilon_{x\theta})_{r=b} \quad (5-510)$$

$$N_{\theta\theta} = \frac{E\tau}{1-\nu^2} (\epsilon_{\theta\theta} + \nu\epsilon_{xx})_{r=b} \quad (5-511)$$

The integral of the bending strains gives no contribution. Solving for the strains gives

$$\frac{\partial p_x}{\partial x} + \Delta_{xx} = \frac{1}{E\tau} (N_{xx} - \nu N_{\theta\theta}) \quad (5-512)$$

$$\frac{1}{2} \frac{\partial p_\theta}{\partial x} + \frac{1}{2t} \frac{\partial p_x}{\partial \theta} + \Delta_{x\theta} = \frac{2(1+\nu)}{E\tau} N_{x\theta} \quad (5-513)$$

$$\frac{1}{t} \frac{\partial p_\theta}{\partial \theta} + \frac{1}{t} p_{rr} = \frac{1}{E\tau} (N_{\theta\theta} - \nu N_{xx}) + \Delta_{\theta\theta} \quad (5-514)$$

The linear part of the membrane strains is then

$$\frac{\partial p_x}{\partial x} = \frac{1}{E\tau} (N_{xx} - \nu N_{\theta\theta}) - \Delta_{xx} \quad (5-515)$$

$$\frac{1}{2} \frac{\partial p_\theta}{\partial x} + \frac{1}{2t} \frac{\partial p_x}{\partial \theta} = \frac{2(1+\nu)}{E\tau} N_{x\theta} - \Delta_{x\theta} \quad (5-516)$$

$$\frac{1}{t} \frac{\partial p_x}{\partial \theta} + \frac{1}{t} p_{rr} = \frac{1}{E\tau} (N_{\theta\theta} - \nu N_{xx}) - \Delta_{\theta\theta} \quad (5-517)$$

Contrails

If we substitute these expressions into the third integral in Equation 5-505, we obtain, for that integral, the expression:

$$\frac{1}{2} \int_0^L \int_0^{2\pi} (N_{xx} \Delta_{xx} + N_{x\theta} \Delta_{x\theta} + N_{\theta\theta} \Delta_{\theta\theta}) t d\theta dx \quad (5-518)$$

where, as before, squared terms in the Δ 's have been neglected. An approximate expression for this integral can be obtained by using the stress resultants for the linear membrane equations. These equations are obtained by neglecting bending and the nonlinear terms. The result can be shown to be given by

$$\frac{\partial N_{xx}}{\partial x} + \frac{1}{b} N_{x\theta} = -(P_x - \rho t \frac{\partial^2 p_x}{\partial t^2}) \quad (5-519)$$

$$+\frac{1}{b} \frac{\partial N_{\theta\theta}}{\partial \theta} + \frac{\partial N_{x\theta}}{\partial x} = -(P_\theta - \rho t \frac{\partial^2 p_\theta}{\partial t^2}) \quad (5-520)$$

$$N_{\theta\theta} = t (P_\theta - \rho t \frac{\partial^2 p_\theta}{\partial t^2}) \quad (5-521)$$

where P_θ , P_θ , and P_x are derived from the virtual work of applied forces,

$$\delta W = \int_0^L \int_0^{2\pi} (t \delta p_\theta P_\theta + t \delta p_x P_x) t d\theta dx \quad (5-522)$$

If we consider only the case where the inertia terms can be neglected, the above equations may be integrated to give

$$N_{xx} = -\int_0^x P_x dx + \frac{1}{b} \int_0^x \int_0^{2\pi} (t \frac{\partial P_\theta}{\partial \theta} + t \frac{\partial P_x}{\partial x}) d\theta dx \quad (5-523)$$

$$N_{x\theta} = -\int_0^x (P_\theta + \frac{\partial P_x}{\partial \theta}) dx \quad (5-524)$$

$$N_{\theta\theta} = t P_\theta \quad (5-525)$$

A case of common interest is that of an axially loaded shell that is internally pressurized. If P is the total axial load (positive for compression) and p_θ is the internal pressure, we have

$$P_x = p_\theta \quad (5-526)$$

$$P_\theta = 0 \quad (5-527)$$

Contrails

$$P_x(\theta, x) = \left(p_0 \frac{b}{2} - \frac{P}{2\pi b} \right) \delta(x-L) - \left(p_0 \frac{b}{2} - \frac{P}{2\pi b} \right) \delta(x) \quad (5-528)$$

where $\delta(x)$ is the Dirac function. For this case, substitution into Equations 5-523, 5-524, and 5-525 gives

$$N_{xx} = p_0 \frac{b}{2} - \frac{P}{2\pi b} \quad \text{for } 0 < x < L \quad (5-529)$$

$$N_{x\theta} = 0 \quad (5-530)$$

$$N_{\theta\theta} = p_0 \frac{\pi b}{2} \quad (5-531)$$

The final expression for the strain energy, using Equation 5-518 and Equations 5-498, 5-499, and 5-500, is

$$\begin{aligned} U = & \frac{1}{2} \int_0^L \int_0^{2\pi} \frac{E T}{1-\nu^2} \left(\left(\frac{\partial P_x}{\partial x} \right)^2 + \left(\frac{1}{b} \frac{\partial P_\theta}{\partial \theta} + \frac{P_r}{b} \right)^2 + 2\nu \frac{\partial P_x}{\partial x} \left(\frac{1}{b} \frac{\partial P_\theta}{\partial \theta} + \frac{P_r}{b} \right) \right. \\ & \left. + \frac{1-\nu}{2} \left(\frac{1}{2} \frac{\partial P_\theta}{\partial x} + \frac{1}{2b} \frac{\partial P_r}{\partial \theta} \right)^2 \right) b \, d\theta \, dx \quad (5-532) \\ & + \frac{1}{2} \int_0^L \int_0^{2\pi} \frac{E T^3}{12(1-\nu^2)} \left(\left(\frac{\partial^2 P_x}{\partial x^2} \right)^2 + \left(\frac{\partial^2 P_r}{b^2 \partial \theta^2} - \frac{1}{b} \frac{\partial P_\theta}{b \partial \theta} \right)^2 + 2\nu \left(\frac{\partial^2 P_x}{\partial x^2} \right) \left(\frac{\partial^2 P_r}{b^2 \partial \theta^2} - \frac{1}{b} \frac{\partial P_\theta}{b \partial \theta} \right) \right. \\ & \left. + 2(1-\nu) \left(\frac{\partial^2 P_r}{b \partial x \partial \theta} - \frac{1}{b} \frac{\partial P_\theta}{\partial x} \right)^2 \right) b \, d\theta \, dx \\ & + \frac{1}{2} \int_0^L \int_0^{2\pi} \left(N_{xx} \left(\left(\frac{\partial P_x}{\partial x} \right)^2 + \left(\frac{\partial P_\theta}{\partial x} \right)^2 + \left(\frac{\partial P_r}{\partial x} \right)^2 \right) \right. \\ & \left. + N_{x\theta} \left(\left(\frac{\partial P_x}{\partial x} \right) \left(\frac{\partial P_r}{b \partial \theta} - \frac{P_\theta}{b} \right) + \left(\frac{\partial P_\theta}{\partial x} \right) \left(\frac{\partial P_\theta}{b \partial \theta} + \frac{P_r}{b} \right) + \left(\frac{\partial P_r}{\partial x} \right) \left(\frac{\partial P_r}{b \partial \theta} \right) \right) \right. \\ & \left. + N_{\theta\theta} \left(\left(\frac{\partial P_r}{b \partial \theta} - \frac{P_\theta}{b} \right)^2 + \left(\frac{\partial P_\theta}{b \partial \theta} + \frac{P_r}{b} \right)^2 + \left(\frac{\partial P_r}{b \partial \theta} \right)^2 \right) \right) b \, d\theta \, dx \end{aligned}$$

5.2.2.2.2 The Kinetic Energy

The total kinetic energy of the shell is

$$\begin{aligned}
 T &= \frac{1}{2} \int \left(\frac{\partial \rho}{\partial t} \right)^2 \rho dV \\
 &= \frac{1}{2} \int_0^L \int_0^{2\pi} \int_{b-\frac{t}{2}}^{b+\frac{t}{2}} \left(\left(\frac{\partial b}{\partial t} \right)^2 + \left(\frac{\partial \rho}{\partial t} \right)^2 + \left(\frac{\partial \theta}{\partial t} \right)^2 \right) \rho b \, d\theta \, db \, dx
 \end{aligned}$$

or

$$T = \frac{1}{2} \int_0^L \int_0^{2\pi} \rho t \left(\left(\frac{\partial b}{\partial t} \right)^2 + \left(\frac{\partial \rho}{\partial t} \right)^2 + \left(\frac{\partial \theta}{\partial t} \right)^2 \right) b \, d\theta \, dx \tag{5-533}$$

5.2.2.2.3 A Finite Degree-of-Freedom Representation of a Cylindrical Shell using Diparabolic Interpolation

5.2.2.2.3.1 Description of the Method

If we choose collocation points spaced at equal intervals on the shell, we can divide the shell surface into a number of regions as in Figure 104.

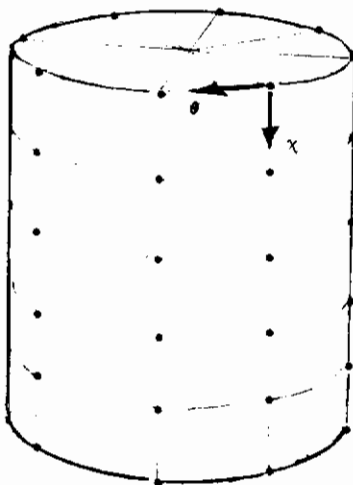

FIGURE 104 COLLOCATION POINTS FOR A CYLINDRICAL SHELL

In Figure 105 a typical region is shown on the inside surface of the developed shell.

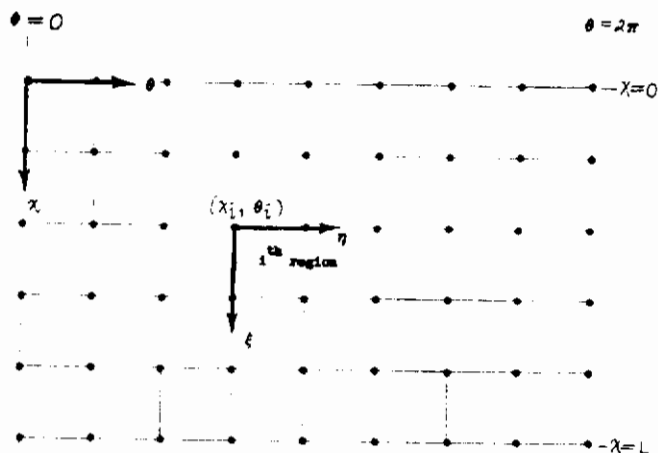

FIGURE 105 INSIDE OF DEVELOPED SHELL SHOWING TYPICAL REGION

For the i^{th} region, let the coordinates of the upper left corner be $x = x_i$ and $\theta = \theta_i$ and introduce non-dimensional coordinates defined by the following equations

$$\xi = \frac{x - x_i}{l} ; \quad l = \frac{L}{M} \quad (5-534)$$

$$\eta = \frac{\theta - \theta_i}{w} ; \quad w = \frac{2\pi}{N} \quad (5-535)$$

The total number of regions is $N \cdot M$, where N and M are integers.

The kinetic energy can then be written as a sum over the $N \cdot M$ regions

$$T = \sum_{i=1}^{N \cdot M} \iint_{S_i} \rho \tau \left(\left(\frac{\partial p_i}{\partial t} \right)^2 + \left(\frac{\partial p_i}{\partial \xi} \right)^2 + \left(\frac{\partial p_i}{\partial \eta} \right)^2 \right) \delta d\xi d\eta \quad (5-536)$$

Contrails

If we change the variable of integration to (ξ, η) , then

$$G d\theta dx = w l d\xi d\eta \quad (5-537)$$

and

$$T = \frac{1}{2} \sum_{i=1}^{N+M} \int_0^1 \int_0^1 \rho \tau w l \left(\left(\frac{\partial p_n}{\partial \xi} \right)^2 + \left(\frac{\partial p_\theta}{\partial \xi} \right)^2 + \left(\frac{\partial p_x}{\partial \xi} \right)^2 \right) d\xi d\eta \quad (5-538)$$

The procedure is very similar to that followed for the plate in Paragraph 2.3.3.2. We assume

$$p_n(\theta, x, t) = \{f(\xi, \eta)\}' [\gamma]_i \{p_n\}_i \quad (5-539)$$

$$p_\theta(\theta, x, t) = \{f(\xi, \eta)\}' [\gamma]_i \{p_\theta\}_i \quad (5-540)$$

$$p_x(\theta, x, t) = \{f(\xi, \eta)\}' [\gamma]_i \{p_x\}_i \quad (5-541)$$

where $\{f(\xi, \eta)\}$ is given in Equation 2-466 of Paragraph 2.3.3.2 and the interpolation coefficients are the same for every region except those regions adjacent to the top and bottom edges. The construction of the edge interpolation coefficients is briefly discussed in Paragraph 2.3.3.2. At the right and left hand edges, the points falling off the surface are not eliminated but will be eliminated later by a compatibility condition at the cut, $\theta = 0$.

Substituting Equations 5-539, 5-540, and 5-541 into the expression for the kinetic energy, we obtain

$$T = \frac{1}{2} \sum_{i=1}^{M+N} \rho \tau w l \left(\{p_n\}_i' [\gamma]_i' [\gamma]_i \{p_n\}_i + \{p_\theta\}_i' [\gamma]_i' [\gamma]_i \{p_\theta\}_i + \{p_x\}_i' [\gamma]_i' [\gamma]_i \{p_x\}_i \right) \quad (5-542)$$

where

$$[\gamma] = \int_0^1 \int_0^1 \{f(\xi, \eta)\}' \{f(\xi, \eta)\}' d\xi d\eta \quad (5-543)$$

Contrails

which is the matrix previously introduced in the plate analysis (see Equation 2-479) and is listed in Appendix IV.

A compatibility matrix can be constructed which relates the displacements of a region to the displacements of the whole shell and sets the displacements along the cut, $\theta = 0$, equal

$$\{p_n\}_i = [\tau]_i \{p_n\} \quad (5-544)$$

The same transformation relates the other components of displacement

$$\{p_\theta\}_i = [\tau]_i \{p_\theta\} \quad (5-545)$$

$$\{p_x\}_i = [\tau]_i \{p_x\} \quad (5-546)$$

Substitution of these relations into the kinetic energy gives

$$\begin{aligned} T = \frac{1}{2} & \left(\{p_n\}' [A_{nn}] \{p_n\} \right. \\ & + \{p_\theta\}' [A_{\theta\theta}] \{p_\theta\} \\ & \left. + \{p_x\}' [A_{xx}] \{p_x\} \right) \end{aligned} \quad (5-547)$$

where

$$\begin{aligned} [A_{nn}] &= [A_{\theta\theta}] = [A_{xx}] \\ &= \sum_{i=1}^{N \cdot M} \rho r w e [\tau]_i' [s]_i' [\tau]_i [s]_i [\tau]_i \end{aligned} \quad (5-548)$$

The strain energy of the shell is considered in the same way. From Equation 5-532, we obtain

$$\begin{aligned} U = \frac{1}{2} \sum_{i=1}^{N \cdot M} \iint_{S_i} \frac{E T^3}{12(1-\nu^2)} & \left(\left(\frac{\partial^2 p}{\partial x^2} \right)^2 + \left(\frac{\partial^2 p}{\partial \theta^2} - \frac{1}{R} \frac{\partial p}{\partial \theta} \right)^2 \right. \\ & + 2\nu \left(\frac{\partial^2 p}{\partial x^2} \right) \left(\frac{\partial^2 p}{\partial \theta^2} - \frac{1}{R} \frac{\partial p}{\partial \theta} \right) \\ & \left. + 2(1-\nu) \left(\frac{\partial^2 p}{\partial x \partial \theta} - \frac{1}{R} \frac{\partial p}{\partial x} \right)^2 \right) R d\theta dx \end{aligned} \quad (5-549)$$

Contrails

When we make the change of variable in Equations 5-534 and 5-535, the derivatives transform as follows:

$$\begin{aligned}
 \frac{\partial^2 p_x}{\partial x^2} &= \frac{1}{l^2} \frac{\partial^2 p_x}{\partial \xi^2} & \frac{\partial p_x}{\partial x} &= \frac{1}{l} \frac{\partial p_x}{\partial \xi} \\
 \frac{\partial^2 p_x}{\partial x^2 \partial \theta^2} &= \frac{1}{w^2} \frac{\partial^2 p_x}{\partial \eta^2} & \frac{\partial p_x}{\partial x \partial \theta} &= \frac{1}{w} \frac{\partial p_x}{\partial \eta} \\
 \frac{\partial p_x}{\partial x \partial \theta} &= \frac{1}{w} \frac{\partial p_x}{\partial \eta} & \frac{\partial p_x}{\partial x} &= \frac{1}{l} \frac{\partial p_x}{\partial \xi} \\
 \frac{\partial^2 p_x}{\partial x \partial \theta} &= \frac{1}{wl} \frac{\partial^2 p_x}{\partial \xi \partial \eta} & \frac{\partial p_x}{\partial x} &= \frac{1}{l} \frac{\partial p_x}{\partial \xi}
 \end{aligned}
 \tag{5-550}$$

also,

$$l dx d\alpha = w l d\xi d\eta \tag{5-551}$$

The strain energy then becomes

$$\begin{aligned}
 U &= \frac{1}{2} \sum_{i=1}^{N \cdot M} \int_0^1 \int_0^1 \frac{E T^2}{2(1-\nu^2)} \left(\frac{w}{l^2} \left(\frac{\partial^2 P_i}{\partial \xi^2} \right)^2 + \frac{l}{w^2} \left(\frac{\partial^2 P_i}{\partial \eta^2} - \frac{w}{l} \frac{\partial P_i}{\partial \eta} \right)^2 \right. \\
 &\quad \left. + \frac{2\nu}{w l} \left(\frac{\partial^2 P_i}{\partial \xi^2} \right) \left(\frac{\partial^2 P_i}{\partial \eta^2} - \frac{w}{l} \frac{\partial P_i}{\partial \eta} \right) + \frac{2(1-\nu)}{w l} \left(\frac{\partial^2 P_i}{\partial \xi \partial \eta} - \frac{w}{l} \frac{\partial P_i}{\partial \xi} \right)^2 \right) d\xi d\eta \\
 &+ \frac{1}{2} \sum_{i=1}^{N \cdot M} \int_0^1 \int_0^1 \frac{E T}{(1-\nu^2)} \left(\frac{w}{l} \left(\frac{\partial P_i}{\partial \xi} \right)^2 + \frac{l}{w} \left(\frac{\partial P_i}{\partial \eta} + \frac{w}{l} P_i \right)^2 \right. \\
 &\quad \left. + 2\nu \left(\frac{\partial P_i}{\partial \xi} \right) \left(\frac{\partial P_i}{\partial \eta} + \frac{w}{l} P_i \right) + \frac{(1-\nu)}{2} \frac{w}{l} \left(\frac{1}{2} \frac{\partial P_i}{\partial \xi} + \frac{l}{2w} \frac{\partial P_i}{\partial \eta} \right)^2 \right) d\xi d\eta \\
 &+ \frac{1}{2} \sum_{i=1}^{N \cdot M} \int_0^1 \int_0^1 \left(N_{xx} \frac{w}{l} \left(\left(\frac{\partial P_i}{\partial \xi} \right)^2 + \left(\frac{\partial P_i}{\partial \eta} \right)^2 + \left(\frac{\partial P_i}{\partial \xi} \right)^2 \right) \right. \\
 &\quad \left. + N_{xy} \left(\left(\frac{\partial P_i}{\partial \xi} \right) \left(\frac{\partial P_i}{\partial \eta} - \frac{w}{l} P_i \right) + \left(\frac{\partial P_i}{\partial \xi} \right) \left(\frac{\partial P_i}{\partial \eta} + \frac{w}{l} P_i \right) + \left(\frac{\partial P_i}{\partial \xi} \right) \left(\frac{\partial P_i}{\partial \eta} \right) \right) \right. \\
 &\quad \left. + N_{yy} \frac{l}{w} \left(\left(\frac{\partial P_i}{\partial \eta} - \frac{w}{l} P_i \right)^2 + \left(\frac{\partial P_i}{\partial \eta} + \frac{w}{l} P_i \right)^2 + \left(\frac{\partial P_i}{\partial \eta} \right)^2 \right) \right) d\xi d\eta
 \end{aligned}
 \tag{5-552}$$

Contrails

Using Equations 5-539, 5-540, and 5-541, we may then express this in terms of a finite number of degrees-of-freedom.

$$\frac{\partial^2 p_n}{\partial s^2} = \left\{ \frac{\partial^2 f}{\partial s^2}(s, \eta) \right\}' [J]_i \{ p_n \}_i \quad (5-553)$$

$$\frac{\partial^2 p_n}{\partial \eta^2} = \left\{ \frac{\partial^2 f}{\partial \eta^2}(s, \eta) \right\}' [J]_i \{ p_n \}_i \quad (5-554)$$

$$\frac{\partial p_n}{\partial \eta} = \left\{ \frac{\partial f}{\partial \eta}(s, \eta) \right\}' [J]_i \{ p_n \}_i \quad (5-555)$$

$$\frac{\partial^2 p_n}{\partial s \partial \eta} = \left\{ \frac{\partial^2 f}{\partial s \partial \eta}(s, \eta) \right\}' [J]_i \{ p_n \}_i \quad (5-556)$$

$$\frac{\partial p_n}{\partial s} = \left\{ \frac{\partial f}{\partial s}(s, \eta) \right\}' [J]_i \{ p_n \}_i \quad (5-557)$$

$$\frac{\partial p_n}{\partial s} = \left\{ \frac{\partial f}{\partial s}(s, \eta) \right\}' [J]_i \{ p_n \}_i \quad (5-558)$$

$$p_n = \{ f(s, \eta) \}' [J]_i \{ p_n \}_i \quad (5-559)$$

$$\frac{\partial p_n}{\partial \eta} = \left\{ \frac{\partial f}{\partial \eta}(s, \eta) \right\}' [J]_i \{ p_n \}_i \quad (5-560)$$

When these terms are substituted into the strain energy, the following type of integrals will result:

$$[r_1] = \int_0^1 \int_0^1 \{ f \} \{ f \}' d s d \eta \quad (5-561)$$

$$[r_2] = \int_0^1 \int_0^1 \left\{ \frac{\partial^2 f}{\partial s^2} \right\}' \{ \frac{\partial^2 f}{\partial s^2} \}' d s d \eta \quad (5-562)$$

$$[r_3] = \int_0^1 \int_0^1 \left\{ \frac{\partial^2 f}{\partial \eta^2} \right\}' \{ \frac{\partial^2 f}{\partial \eta^2} \}' d s d \eta \quad (5-563)$$

$$[r_4] = \int_0^1 \int_0^1 \left\{ \frac{\partial^2 f}{\partial s \partial \eta} \right\}' \{ \frac{\partial^2 f}{\partial s \partial \eta} \}' + \left\{ \frac{\partial f}{\partial \eta} \right\}' \{ \frac{\partial f}{\partial s} \}' d s d \eta \quad (5-564)$$

$$[r_5] = \int_0^1 \int_0^1 \left\{ \frac{\partial f}{\partial s \partial \eta} \right\}' \{ \frac{\partial f}{\partial s \partial \eta} \}' d s d \eta \quad (5-565)$$

$$[r_7] = \int_0^1 \int_0^1 \left\{ \frac{\partial f}{\partial s} \right\}' \{ \frac{\partial f}{\partial s} \}' d s d \eta \quad (5-566)$$

$$[r_8] = \int_0^1 \int_0^1 \left\{ \frac{\partial f}{\partial \eta} \right\}' \{ \frac{\partial f}{\partial \eta} \}' d s d \eta \quad (5-567)$$

Contrails

$$[\Gamma_9] = \int_0^1 \int_0^1 \frac{1}{2} \left(\left\{ \frac{\partial^2 f}{\partial s^2} \right\} \left\{ \frac{\partial^2 f}{\partial \eta^2} \right\}' + \left\{ \frac{\partial^2 f}{\partial s \partial \eta} \right\} \left\{ \frac{\partial^2 f}{\partial s \partial \eta} \right\}' \right) ds d\eta \quad (5-568)$$

$$[\Gamma_{10}] = \int_0^1 \int_0^1 \left\{ \frac{\partial^2 f}{\partial s^2} \right\} \left\{ \frac{\partial^2 f}{\partial \eta^2} \right\} ds d\eta \quad (5-569)$$

$$[\Gamma_{11}] = \int_0^1 \int_0^1 \left\{ \frac{\partial^2 f}{\partial \eta^2} \right\} \left\{ \frac{\partial^2 f}{\partial s^2} \right\}' ds d\eta \quad (5-570)$$

$$[\Gamma_{12}] = \int_0^1 \int_0^1 \left\{ \frac{\partial^2 f}{\partial s^2} \right\} \left\{ \frac{\partial^2 f}{\partial \eta^2} \right\}' ds d\eta \quad (5-571)$$

$$[\Gamma_{13}] = \int_0^1 \int_0^1 \left\{ \frac{\partial^2 f}{\partial s \partial \eta} \right\} \left\{ \frac{\partial^2 f}{\partial s} \right\}' ds d\eta \quad (5-572)$$

$$[\Gamma_{14}] = \int_0^1 \int_0^1 \frac{\left\{ f \right\} \left\{ \frac{\partial f}{\partial \eta} \right\}' - \left\{ \frac{\partial f}{\partial \eta} \right\} \left\{ f \right\}'}{2} ds d\eta \quad (5-573)$$

$$[\Gamma_{15}] = \int_0^1 \int_0^1 \frac{\left\{ f \right\} \left\{ \frac{\partial f}{\partial s} \right\}' - \left\{ \frac{\partial f}{\partial s} \right\} \left\{ f \right\}'}{2} ds d\eta \quad (5-574)$$

$$[\Gamma_{16}] = \int_0^1 \int_0^1 \left\{ \frac{\partial f}{\partial \eta} \right\} \left\{ \frac{\partial f}{\partial s} \right\}' ds d\eta \quad (5-575)$$

These integrals of polynomials can be easily evaluated independently of the geometry of the shell and are tabulated in Appendix IV.

Substitution of Equations 5-553 through 5-560 into Equation 5-552 gives

$$U = \frac{1}{2} \sum_{i=1}^{N \times M} \left(\begin{aligned} & \left\{ p_n \right\}'_i \left\{ s \right\}'_i \left[\Gamma_{11} \right] \left\{ s \right\}_i \left\{ p_n \right\}_i \\ & + 2 \left\{ p_n \right\}'_i \left\{ s \right\}'_i \left[\Gamma_{10} \right] \left\{ s \right\}_i \left\{ p_o \right\}_i \\ & + 2 \left\{ p_n \right\}'_i \left\{ s \right\}'_i \left[\Gamma_{12} \right] \left\{ s \right\}_i \left\{ p_x \right\}_i \\ & + \left\{ p_o \right\}'_i \left\{ s \right\}'_i \left[\Gamma_{13} \right] \left\{ s \right\}_i \left\{ p_o \right\}_i \\ & + 2 \left\{ p_o \right\}'_i \left\{ s \right\}'_i \left[\Gamma_{14} \right] \left\{ s \right\}_i \left\{ p_x \right\}_i \\ & + \left\{ p_x \right\}'_i \left\{ s \right\}'_i \left[\Gamma_{15} \right] \left\{ s \right\}_i \left\{ p_x \right\}_i \end{aligned} \right) \quad (5-576)$$

Contrails

where

$$[\Gamma_7] = \frac{E\tau^3}{wL^2(1-\nu^2)} \left(\frac{12(\frac{b}{L})^2 \cdot \frac{2\pi^3}{N}}{\frac{b^2}{L^2}} [\Gamma_1] + \frac{N_{xx}}{L} [\Gamma_2] + \left(\frac{b}{w}\right)^2 [\Gamma_3] + 2\nu [\Gamma_4] + 2(1-\nu) [\Gamma_5] \right. \\ \left. + N_{xx} \frac{w}{L} [\Gamma_7] + N_{\theta\theta} \frac{b}{w} [\Gamma_8] + N_{x\theta} [\Gamma_9] \right) \\ + N_{\theta\theta} \left(\frac{2\pi}{N}\right)^2 [\Gamma_1] \quad (5-577)$$

$$[\Gamma_{10e}] = \frac{E\tau^3}{wL^2(1-\nu^2)} \left(\frac{24(\frac{b}{L})^2 \frac{2\pi^3}{N}}{\left(\frac{b}{L}\right)^2} [\Gamma_{10}] - \frac{2(\frac{2\pi}{N})}{\left(\frac{b}{L}\right)^2} [\Gamma_{12}] - 2\nu \frac{2\pi}{N} [\Gamma_{13}] \right. \\ \left. - 4(1-\nu) \left(\frac{2\pi}{N}\right) [\Gamma_{14}] \right) \\ + N_{\theta\theta} \frac{b}{w} \left(\frac{2\pi}{N}\right) [\Gamma_{15}] + 2N_{x\theta} \left(\frac{2\pi}{N}\right) [\Gamma_{16}] \quad (5-578)$$

$$[\Gamma_{17x}] = \frac{E\tau}{wL(1-\nu^2)} \frac{b}{w} \left(\frac{b}{L}\right)^2 \left(\frac{2\pi}{N}\right)^3 \nu [\Gamma_6] \quad (5-579)$$

$$[\Gamma_{\theta\theta}] = \frac{E\tau^3}{wL^2(1-\nu^2)} \left(1 + \frac{3}{4} \left(\frac{b}{L}\right)^2 \right) 2(1-\nu) \left(\frac{2\pi}{N}\right)^2 [\Gamma_7] \\ + \frac{E\tau^3}{wL^2(1-\nu^2)} \left(1 + 12 \left(\frac{b}{L}\right)^2 \right) \left(\frac{2\pi}{N}\right)^2 \left(\frac{b}{w}\right)^2 [\Gamma_8] \quad (5-580)$$

$$+ \frac{b}{w} N_{\theta\theta} \left(\frac{2\pi}{N}\right)^2 [\Gamma_1] + \frac{w}{L} N_{xx} [\Gamma_7] + \frac{b}{w} N_{\theta\theta} [\Gamma_8] + N_{x\theta} [\Gamma_9]$$

$$[\Gamma_{\theta x}] = \frac{E\tau^3}{2wL(1-\nu^2)} \left(\frac{b}{L}\right)^2 \frac{b}{w} \left(\frac{2\pi}{N}\right)^2 \left(\frac{1-\nu}{4} [\Gamma_{11}] + 2\nu [\Gamma_{17}] \right) \quad (5-581)$$

$$[\Gamma_{xx}] = \frac{E\tau^3}{wL^2(1-\nu^2)} \left(12 \left(\frac{b}{L}\right)^2 \left(\frac{2\pi}{N}\right)^2 [\Gamma_7] + 2(1-\nu) \frac{3}{4} \left(\frac{b}{L}\right)^2 \left(\frac{2\pi}{N}\right)^2 \left(\frac{b}{w}\right)^2 [\Gamma_8] \right) \\ + \left(\frac{w}{L}\right) N_{xx} [\Gamma_7] + \left(\frac{b}{w}\right) N_{\theta\theta} [\Gamma_8] + N_{x\theta} [\Gamma_9] \quad (5-582)$$

Now, using the compatibility transformations (Equations 5-544, 5-545, and 5-546), we have

$$U = \frac{1}{2} \left(\{p_n\}' [K_{nn}] \{p_n\} + 2 \{p_n\}' [K_{n\theta}] \{p_\theta\} + 2 \{p_n\}' [K_{nx}] \{p_x\} \right. \\ \left. + \{p_\theta\}' [K_{\theta\theta}] \{p_\theta\} + 2 \{p_\theta\}' [K_{\theta x}] \{p_x\} \right. \\ \left. + \{p_x\}' [K_{xx}] \{p_x\} \right) \quad (5-583)$$

where

$$[K_{nn}] = \sum_{i=1}^{N+M} [\tau]_i' [J]_i' [\Gamma_{nn}] [J]_i [\tau]_i \quad (5-584)$$

$$[K_{n\theta}] = \sum_{i=1}^{N+M} [\tau]_i' [J]_i' [\Gamma_{n\theta}] [J]_i [\tau]_i \quad (5-585)$$

$$[K_{rx}] = \sum_{i=1}^{N-M} [\tau]_i' [J]_i' [r_{rx}] [J]_i [\tau]_i \quad (5-586)$$

$$[K_{\theta\theta}] = \sum_{i=1}^{N-M} [\tau]_i' [J]_i' [r_{\theta\theta}] [J]_i [\tau]_i \quad (5-587)$$

$$[K_{\theta x}] = \sum_{i=1}^{N-M} [\tau]_i' [J]_i' [r_{\theta x}] [J]_i [\tau]_i \quad (5-588)$$

$$[K_{xx}] = \sum_{i=1}^{N-M} [\tau]_i' [J]_i' [r_{xx}] [J]_i [\tau]_i \quad (5-589)$$

5.2.2.2.3.2 Analysis of a Copper Shell

In order to demonstrate the method, we consider the following problem:

Determine the vibration modes of a "freely supported" shell with no internal pressure and no axial load. The geometrical parameters for the shell are

- L = length = 15.5 inches
- b = radius = 8 inches
- T = thickness = 0.0032 inches

The shell is made of homogeneous copper for which

$$\begin{aligned} \rho &= 0.322 \text{ lb}_m / \text{in}^3 \\ \nu &= 0.3 \\ E &= 13 \times 10^6 \text{ lb}_F / \text{in}^2 \end{aligned}$$

The interval $(0, 2\pi)$ of θ , was divided into 4 equally spaced intervals and the interval $(0, L)$ was divided in 5 equally spaced intervals. The developed shell surface was therefore divided into 20 regions of length,

$$l = \frac{L}{5} \quad (5-590)$$

and width,

$$w = \frac{2\pi b}{4} \quad (5-591)$$

There are then 2^4 collocation points and 72 degrees-of-freedom. To describe the freely supported condition, all components of displacement are set to zero for the points on the ends. These 12 conditions at each end reduce the system from 72 degrees-of-freedom to 48 degrees-of-freedom. These constraints can be described by a transformation of the form

$$\{p_n\} = [T_n] \{p\} \quad (5-592)$$

Contrails

$$\{p_\theta\} = [T_\theta] H \{p\} \quad (5-593)$$

$$\{p_\lambda\} = [T_\lambda] H \{p\} \quad (5-594)$$

The kinetic energy and strain energy for this problem are then

$$T = \frac{1}{2} \{ \dot{p} \}' [A] H \{ \dot{p} \} \quad (5-595)$$

$$U = \frac{1}{2} \{ p \}' [K] H \{ p \} \quad (5-596)$$

where

$$[A] = [T_\lambda]' [A_{\lambda\lambda}] [T_\lambda] + [T_\theta]' [A_{\theta\theta}] [T_\theta] + [T_\lambda]' [A_{\lambda\lambda}] [T_\lambda] \quad (5-597)$$

and

$$\begin{aligned} [K] = & [T_\lambda]' [K_{\lambda\lambda}] [T_\lambda] + [T_\lambda]' [K_{\theta\lambda}] [T_\theta] + [T_\lambda]' [K_{\lambda\lambda}] [T_\lambda] \\ & + [T_\theta]' [K_{\theta\lambda}] [T_\lambda] + [T_\theta]' [K_{\theta\theta}] [T_\theta] + [T_\theta]' [K_{\theta\lambda}] [T_\lambda] \\ & + [T_\lambda]' [K_{\lambda\lambda}] [T_\lambda] + [T_\lambda]' [K_{\theta\lambda}] [T_\theta] + [T_\lambda]' [K_{\lambda\lambda}] [T_\lambda] \end{aligned} \quad (5-598)$$

The influence coefficients are then

$$[E] = [K]^{-1} \quad (5-599)$$

The vibration modes and frequencies are obtained from

$$[E] [A] H \{ \varphi \} = \lambda \{ \varphi \} \quad (5-600)$$

TABLE 12
 FREQUENCIES FOR A THIN COPPER SHELL
 (c.p.s.)

1	2	3	4	5	6	7	8	9	10	11	12	13	14
55.89	55.89	70.69	92.00	92.00	115.59	115.59	129.02	129.02	138.29	139.56	141.44	141.97	142.13

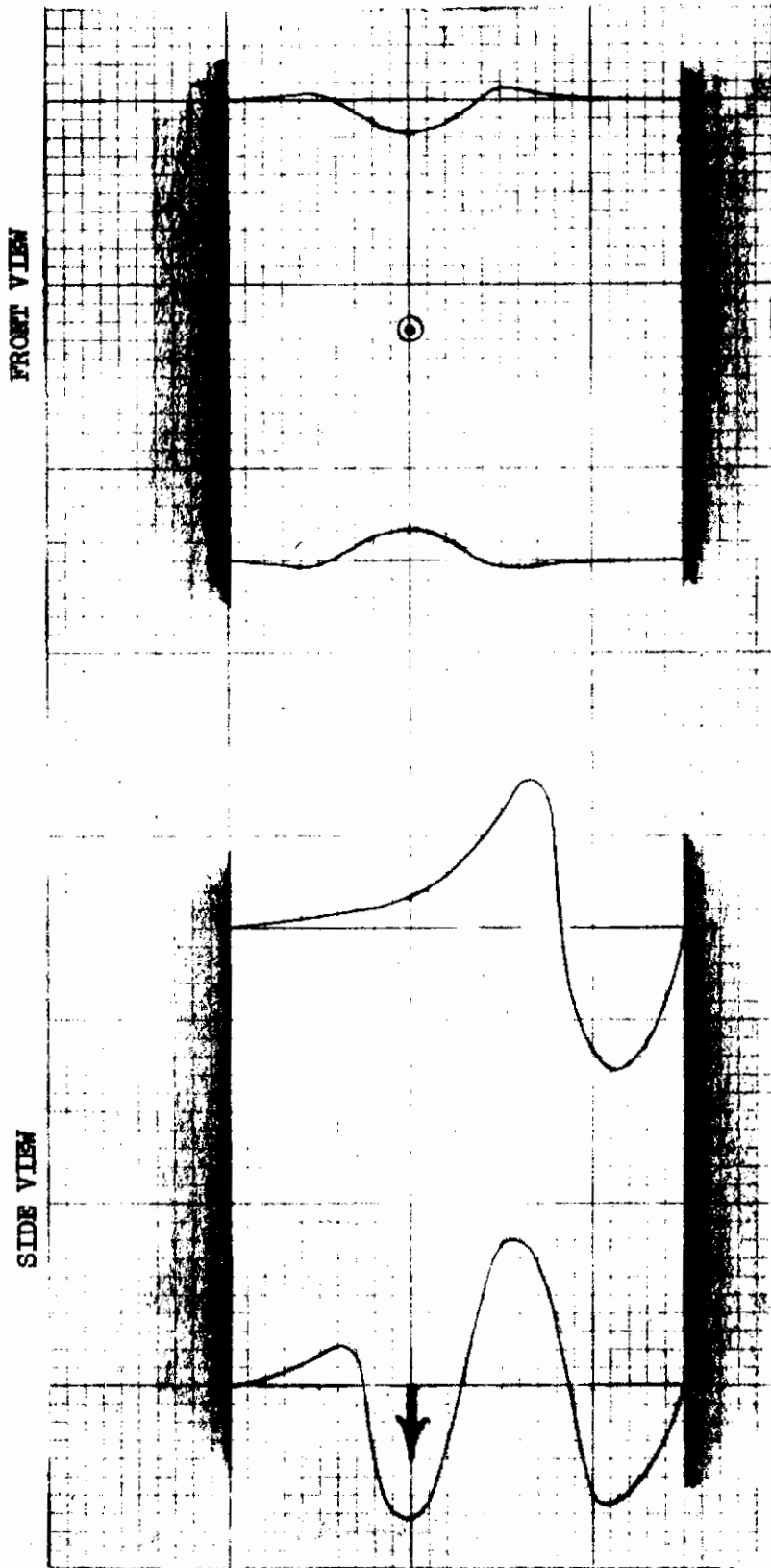

FIGURE 106 INFLUENCE COEFFICIENTS FOR SIMPLY-SUPPORTED SHELL

5.2.2.3 The Effects of Axial Load and Internal Pressure on the Vibration of Beams as Derived from Thin Shell Theory

The significant thin shell effects of internal pressure and axial load can be retained in an approximation which leads to a beam theory model appropriate for slender cylindrical shells.

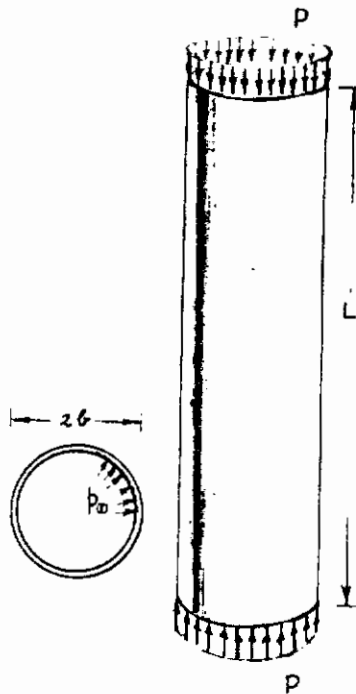

FIGURE 107 SLENDER CYLINDRICAL SHELL

For an axial compression load, P , and an internal pressure, p_0 , the membrane theory stress resultants are (from Equations 5-529, 5-530, and 5-531)

$$N_{xx} = p_0 \frac{t}{2} - \frac{P}{2\pi b} \quad (5-601)$$

$$N_{x\theta} = 0 \quad (5-602)$$

$$N_{\theta\theta} = p_0 \frac{\pi b^2}{2} \quad (5-603)$$

The expression for the strain energy derived in the previous section can be used to obtain an approximate expression for the strain energy involving integration with respect to x only and thus of the same form as the strain energy for a beam.

Using Equations 5-601, 5-602, and 5-603 in Equation 5-532, we obtain the following expression for the strain energy.

$$\begin{aligned}
 U = \frac{1}{2} \int_0^L \int_0^{2\pi} \frac{E\tau}{1-\nu^2} & \left(\left(\frac{\partial p_x}{\partial x} \right)^2 + \left(\frac{1}{r} \frac{\partial p_\theta}{\partial \theta} + \frac{p_r}{r} \right)^2 + 2\nu \left(\frac{\partial p_x}{\partial x} \right) \left(\frac{1}{r} \frac{\partial p_\theta}{\partial \theta} + \frac{p_r}{r} \right) \right. \\
 & + \frac{1-\nu}{2} \left(\frac{1}{r} \frac{\partial p_\theta}{\partial x} + \frac{1}{r} \frac{\partial p_x}{\partial \theta} \right)^2 + \frac{E\tau^2}{12(1-\nu^2)} \left(\left(\frac{\partial^2 p_x}{\partial x^2} \right)^2 + \left(\frac{\partial^2 p_x}{\partial x \partial \theta} - \frac{1}{r} \frac{\partial p_\theta}{\partial x} \right)^2 \right. \\
 & + 2\nu \left(\frac{\partial^2 p_x}{\partial x^2} \right) \left(\frac{\partial^2 p_x}{\partial x \partial \theta} - \frac{1}{r} \frac{\partial p_\theta}{\partial x} \right) + 2(1-\nu) \left(\frac{\partial^2 p_x}{\partial x \partial \theta} - \frac{1}{r} \frac{\partial p_\theta}{\partial x} \right)^2 \\
 & + \left(p_\infty \frac{r}{2} - \frac{p}{2\pi r} \right) \left(\left(\frac{\partial p_x}{\partial x} \right)^2 + \left(\frac{\partial p_\theta}{\partial x} \right)^2 + \left(\frac{\partial p_x}{\partial x} \right)^2 \right) \\
 & + p_\infty \frac{\pi r}{2} \left(\left(\frac{\partial p_x}{\partial \theta} - \frac{p_r}{r} \right)^2 + \left(\frac{\partial p_\theta}{\partial \theta} + \frac{p_r}{r} \right)^2 + \left(\frac{\partial p_x}{\partial \theta} \right)^2 \right) r d\theta dx
 \end{aligned} \tag{5-604}$$

If we now constrain the displacements so that sections normal to the x-axis remain plane during the deformation, the result should yield an Euler-Bernoulli beam theory model¹. The shell displacements in this case are

$$p_x(\theta, x, t) = p_x(x, t) - r \sin \theta \frac{\partial p_z}{\partial x}(x, t) \tag{5-605}$$

$$p_\theta(\theta, x, t) = \sin \theta p_z(x, t) \tag{5-606}$$

$$p_\infty(\theta, x, t) = \cos \theta p_z(x, t) \tag{5-607}$$

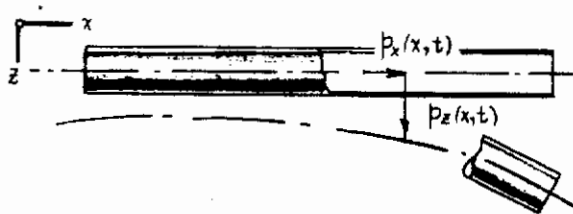

FIGURE 108 BEAM DISPLACEMENTS FOR A CYLINDRICAL SHELL

¹This procedure is similar to that suggested by Enrico Volterra in his "Method of Internal Constraints" (see Volterra, E., The Method of Internal Constraints and Its Application to Static and Dynamic Problems Journal of the Engineering Mechanics Division, A.S.C.E., Aug. 1961, pp 103-127) Volterra's method shows promise for a more systematic and realistic reduction of a shell-like structure to a beam.

Contrails

The derivatives in the strain energy are then

$$\frac{\partial p_x}{\partial x}(\theta, x, t) = \frac{\partial p_x}{\partial x}(x, t) - t \sin \theta \frac{\partial^2 p_z}{\partial x^2}(x, t) \quad (5-608)$$

$$\frac{\partial p_\theta}{\partial \theta}(\theta, x, t) + p_n(\theta, x, t) = -\sin \theta p_z + \sin \theta p_z = 0 \quad (5-609)$$

$$\frac{\partial p_\theta}{\partial x}(\theta, x, t) + \frac{1}{t} \frac{\partial p_x}{\partial \theta}(\theta, x, t) = \cos \theta \frac{\partial p_z}{\partial x} - \frac{1}{t} t \cos \theta \frac{\partial p_z}{\partial x} = 0 \quad (5-610)$$

$$\frac{\partial^2 p_x}{\partial \theta^2}(\theta, x, t) - \frac{\partial p_\theta}{\partial \theta}(\theta, x, t) = -\sin \theta p_z + \sin \theta p_z = 0 \quad (5-611)$$

$$\frac{\partial^2 p_n}{\partial x^2}(\theta, x, t) = \sin \theta \frac{\partial^2 p_z}{\partial x^2}(x, t) \quad (5-612)$$

$$\frac{\partial^2 p_n}{\partial x \partial \theta}(\theta, x, t) - \frac{\partial p_\theta}{\partial x}(\theta, x, t) = \cos \theta \frac{\partial p_z}{\partial x} - \cos \theta \frac{\partial p_z}{\partial x} = 0 \quad (5-613)$$

$$\frac{\partial p_n}{\partial x}(\theta, x, t) = \sin \theta \frac{\partial p_z}{\partial x}(x, t) \quad (5-614)$$

$$\frac{\partial p_\theta}{\partial x}(\theta, x, t) = \cos \theta \frac{\partial p_z}{\partial x}(x, t) \quad (5-615)$$

$$\frac{\partial p_x}{\partial x}(\theta, x, t) = \frac{\partial p_x}{\partial x}(x, t) - t \sin \theta \frac{\partial^2 p_z}{\partial x^2}(x, t) \quad (5-616)$$

$$\frac{\partial p_x}{\partial \theta}(\theta, x, t) - p_\theta(\theta, x, t) = \cos \theta p_z - \cos \theta p_z = 0 \quad (5-617)$$

$$\frac{\partial p_\theta}{\partial \theta}(\theta, x, t) + p_n(\theta, x, t) = -\sin \theta p_z + \sin \theta p_z = 0 \quad (5-618)$$

$$\frac{\partial p_x}{\partial \theta}(\theta, x, t) = -t \cos \theta \frac{\partial p_z}{\partial x}(x, t) \quad (5-619)$$

Substituting these in the strain energy gives

$$\begin{aligned} U = \frac{1}{2} \int_0^L \int_0^{2\pi} \frac{E t}{1-\nu^2} & \left(\left(\frac{\partial p_x}{\partial x} \right)^2 - 2t \sin \theta \frac{\partial p_x}{\partial x} \frac{\partial^2 p_z}{\partial x^2} + t^2 \sin^2 \theta \left(\frac{\partial^2 p_z}{\partial x^2} \right)^2 \right) \\ & + \frac{E t^3}{12(1-\nu^2)} \left(\sin^4 \theta \left(\frac{\partial^2 p_z}{\partial x^2} \right)^2 \right) \\ & + \left(p_0 \frac{b}{2} - \frac{P}{2\pi b} \right) \left(\sin^2 \theta \left(\frac{\partial p_x}{\partial x} \right)^2 + \cos^2 \theta \left(\frac{\partial p_x}{\partial x} \right)^2 \right) \\ & + \left(\frac{\partial p_x}{\partial x} \right)^2 - 2t \sin \theta \frac{\partial p_x}{\partial x} \frac{\partial^2 p_z}{\partial x^2} + t^2 \sin^2 \theta \left(\frac{\partial^2 p_z}{\partial x^2} \right)^2 \\ & + p_0 \frac{\pi b}{2} \cos^2 \theta \left(\frac{\partial p_x}{\partial x} \right)^2 \quad t d\theta dx \end{aligned} \quad (5-620)$$

Contrails

We can now make an explicit integration with respect to θ , using:

$$\int_0^{2\pi} \sin \theta d\theta = 0 \quad (5-621)$$

$$\int_0^{2\pi} \sin^2 \theta d\theta = \pi \quad (5-622)$$

$$\int_0^{2\pi} \cos^2 \theta d\theta = \pi \quad (5-623)$$

The result is

$$U = \frac{1}{2} \int_0^L \left(\frac{Et}{1-\nu^2} (2\pi \frac{\partial p_x}{\partial x})^2 + b^2 \pi (\frac{\partial^2 p_x}{\partial x^2})^2 \right. \\ \left. + \frac{Et^3 \pi}{12(1-\nu^2)} (\frac{\partial^2 p_x}{\partial x^2})^2 \right. \\ \left. + (p_0 \frac{b}{2} - \frac{P}{2\pi b}) \left(2\pi (\frac{\partial p_x}{\partial x})^2 + 2\pi (\frac{\partial p_x}{\partial x})^2 + b^2 \pi (\frac{\partial^2 p_x}{\partial x^2})^2 \right) \right. \\ \left. + p_0 \frac{\pi b}{2} \pi (\frac{\partial p_x}{\partial x})^2 \right) dx \quad (5-624)$$

On collecting terms, we can write this as

$$U = \frac{1}{2} \int_0^L \left(EI (\frac{\partial^2 p_x}{\partial x^2})^2 + EA (\frac{\partial p_x}{\partial x})^2 + N (\frac{\partial p_x}{\partial x})^2 \right) dx. \quad (5-625)$$

where the equivalent beam section properties are

$$EI = \frac{Et b^3 \pi}{(1-\nu^2)} + \frac{Et^3 \pi b}{12(1-\nu^2)} + (p_0 \frac{b}{2} - \frac{P}{2\pi b}) b^3 \pi \quad (5-626)$$

$$EA = \frac{Et b \pi}{1-\nu^2} + 2\pi \left(p_0 \frac{b}{2} - \frac{P}{2\pi b} \right) b \quad (5-627)$$

$$N = p_0 \pi b^2 - P + p_0 \frac{\pi b^2}{2} = p_0 b^2 \left(\pi + \frac{\pi}{2} \right) - P \quad (5-628)$$

In order to include the important effects of shear energy, the Timoshenko-Beam displacements could be assumed instead of the Euler-Bernoulli assumptions made in Equations 5-605, 5-606, and 5-607.

6.0 CONCLUSIONS AND RECOMMENDATIONS

During the course of the investigations that are documented in this report, two distinct problems were explored which appear to be fruitful for additional development.

The first area for future work is the completion of a "production" digital program which will give complete dynamic simulation for a complex (clustered, for example) configuration in general six (rigid body) degree-of-freedom motion. This would necessitate incorporation of coordinate dependent forces into the existing six degree-of-freedom flexible body trajectory routine (see Appendix II). In addition, careful consideration should be given to selecting analytical schemes and governing differential equations for control systems of a general and variable nature. Using relations for detailed forces developed in section 4.2, subroutines should be coded which calculate generalized forces that appear in the equations of motion for the existing computer program. In summary, the result would be the development of a single computer routine to completely simulate the mission of a complex clustered booster including detailed dynamic simulation of a general linear or non-linear control system, as well as simulation of atmospheric turbulence, gross wind profiles, thrust, drag, gravity, and fuel slosh.

The second area for future work is the further investigation of the interpolation procedure (see section 2.3 and 5.2.2.2.3) for the dynamic analysis of shell-like structures with complex geometries. The method should be extended and demonstrated in the analysis of conical shells and shells with additional stiffening from rings and longerons. Detailed demonstrations of the method in the case of axial loads and pressurization should be performed to compare with available theory and test data.

7.0 LIST OF REFERENCES

1. Arnold, R. N. and Warburton, G. B., Flexural Vibrations of the Walls of Thin Cylindrical Shells Having Freely Supported Ends, Proceedings of the Royal Society of London, England, Series A, Vol. 197, 1949.
2. Bisplinghoff, Ashley and Halfman, Aeroelasticity, Addison-Wesley, 1955.
3. Bohne, Q. R., Et. al., The Dynamic Response of Advanced Vehicles, WADD TR-60-518, Sept. 1960.
4. Caughey, T. K. and O'Kelly, M. E. J., The Effect of Damping on the Natural Frequencies of Linear Dynamic Systems, Journal of the Acoustical Society of America, volume 33, No. 11, Nov. 1961.
5. Caughey, T. K., Classical Normal Modes in Damped Linear Dynamic Systems, Journal of Applied Mechanics, 27 E., 1960.
6. Constant, Theoretical Physics, Addison-Wesley, 1954.
7. Courant, R. and Hilbert, D., Methods of Mathematical Physics, Interscience, volume I, 1953.
8. Foss, K. A., Coordinates Which Uncouple the Equations of Motion of Damped Linear Dynamic Systems, Journal of Applied Mechanics, Sept., 1958.
9. Fraeys de Veubike, B. M., Iteration in Semidefinite Eigenvalue Problems, Journal of the Aeronautical Sciences, Oct., 1955.
10. Frazer, Duncan, and Collar, Elementary Matrices, Cambridge University Press, 1950.
11. Goldstein, Sydney, Lectures in Fluid Mechanics, Interscience, 1960.
12. Green and Zerna, Theoretical Elasticity, Oxford, 1954.
13. Griffin, J. A., A Diparabolic Method of Four-Point Interpolation, Journal of the Aeronautical Sciences, Vol. 28, No. 2, Reader's Forum, Feb. 1961.
14. Huang, T. C., The Effect of Rotary Inertia and of Shear Deformation on the Frequency and Normal Mode Equations of a Uniform Beam with Simple End Conditions, Journal of Applied Mechanics, Dec. 1961.
15. Jeffreys, H., Cartesian Tensors, 1931.
16. Keith, J. S., Lincoln, J. W., and Tarnower, G., Aeroelastic Analyses of Multi-Stage Rocket Systems, AGARD Report 390, July 1961.
17. Kellogg, O. D., Foundations of Potential Theory, Dover, 1953.
18. Lamb, H., Hydrodynamics, Dover, 1945.

Contrails

19. Lanczos, Cornelius, The Variational Principles of Mechanics, Toronto Press, 1949.
20. Loring, S. J., General Approach to the Flutter Problem, SAE Journal (Transactions) Volume 49, No. 2, Jan. 6, 1940.
21. Loring, S. J., Use of Generalized Coordinates in Flutter Analysis, SAE Journal, Volume 52, No. 4, April 1944.
22. Press, Harry, Meadows, May T., and Hadlock, Ivan, A Reevaluation of Data on Atmospheric Turbulence for Application in Spectral Calculations, NASA Report 1272, 1956.
23. Rayleigh, Theory of Sound, Volume I, Sec. 102, Dover, 1945.
24. Acanlan and Rosenbaum, An Introduction to the Study of Aircraft Vibration and Flutter, Macmillan, 1951.
25. Synge and Griffith, Principles of Mechanics, McGraw-Hill, Third Edition, 1959.
26. Timoshenko and Woinowsky-Krieger, Theory of Plates and Shells, McGraw-Hill, 1959.
27. Truesdell, C., Principles of Continuum Mechanics, Colloquim Lectures in Pure and Applied Science No. 5 Socony Mobil Oil Co. Field Research Laboratory, Dallas, Texas, Feb. 1960.
28. Truxal, John G., Control System Synthesis, McGraw-Hill, 1955.
29. Tsien, H. S., Engineering Cybernetics, McGraw-Hill, 1954.
30. Volterra, Enrico, On Elastic Continua with Hereditary Characteristics, Journal of Applied Mechanics, Sept., 1951.
31. Volterra, E., The Method of Internal Constraints and Its Application to Static and Dynamic Problems, Journal of the Engineering Mechanics Division, A.S.C.E., Aug. 1961.
32. Watts, George A., Vibration and Damping of Thin-Walled Cylinders, A.E. Thesis, California Institute of Technology, 1962.
33. Wills, A. P., Vector Analysis with an Introduction to Tensor Analysis, Dover, 1958.
34. Whittaker, E. T., A Treatise on the Analytical Dynamics of Particles and Rigid Bodies, Cambridge, 1961.
35. Young, Dana, and Felgar, Robert P., Tables of Characteristic Functions Representing Normal Modes of Vibration of a Beam, University of Texas Publication No. 4913, July 1, 1941.
36. Reference Manual 709/7090 FORTRAN Programming System, C28-6054-2, IBM Corp. 1961.

Contrails

APPENDIX I

A DIGITAL ROUTINE FOR SOLVING THE EQUATIONS OF MOTION
OF A SINGLE ELASTIC BODY EXECUTING LARGE "RIGID-BODY"
MOTIONS AND ACTED UPON BY FORCES WHICH ARE A FUNCTION
OF TIME ALONE

Contrails

Contrails

CONTENTS OF APPENDIX I

	<u>Page</u>
1.0 INTRODUCTION	497
2.0 EQUATIONS SOLVED BY THE ROUTINE	500
3.0 DESCRIPTION OF DIGITAL ROUTINE NO. LVV ⁴ 20-PANDORA.	505
3.1 The Order in Which Data is Presented to the Machine . . .	505
3.2 Details of the Mechanics of Reading Data into the Computer	507
3.2.1 Mechanics of Entering Arrays	510
3.2.2 General Form of Data Sheets for Routine Pandora. .	510
3.2.3 Core Storage Allocation.	512
3.2.3.1 Core Storage Allocations for Subscripted Variables	512
3.2.3.2 Equivalent "P" Allocations for Data Entered in Array Form	513
3.2.4 Source Program Listings.	518
4.0 SAMPLE ANALYSIS USING DIGITAL ROUTINE.	537
4.1 Geometry and Basic Data for Multi-Cylinder Model to be Used in Checking Digital Routine	537
4.2 Sample Problems	555

Contrails

Contrails

1.0 INTRODUCTION

The equations which were coded are given in Section 4.0 equations 4-289 through 4-315.

For the purposes of numerical integration it is desirable to isolate the highest derivatives. In Equation 4-295 we have

$$\begin{aligned} [\Gamma]\{\dot{h}\} = & -[\Gamma][G]\{\dot{p}\} + [\Gamma][H]\{\dot{p}\} + [\Gamma]\{K\} \\ & - [K]\{\dot{p}\} - [B]\{\dot{p}\} + \{P\} \end{aligned} \quad (I-1)$$

Since $[\Gamma]$ is singular (it only has rank $N-6$) it is desirable to define h_i so that instead of

$$\{h\} = \left\{ \frac{\partial I}{\partial p_i} \right\}, \quad (I-2)$$

we have

$$\{h\} = [\Gamma] \left\{ \frac{\partial I}{\partial p_i} \right\} \quad (I-3)$$

Then Equation I-1, above, is replaced by

$$\begin{aligned} \{\dot{h}\} = & -[\Gamma][G]\{\dot{p}\} + [\Gamma][H]\{\dot{p}\} + [\Gamma]\{K\} \\ & - [K]\{\dot{p}\} - [B]\{\dot{p}\} + \{P\} \end{aligned} \quad (I-4)$$

Equation 4-296 is replaced by

$$\{h\} = [\Gamma] \left([A]\{\dot{p}\} + [G]\{\dot{p}\} \right) \quad (I-5)$$

but

Contrails

$$\begin{aligned} [\Gamma][A]\dot{p} &= (\Gamma_1 - [A]\varphi_R'[A][\varphi_R])^{-1}(\varphi_R)'[A]H\dot{p} \\ &= [A]H\dot{p} - [A]\varphi_R'[A][\varphi_R]^{-1}(\varphi_R)'[A]H\dot{p} \end{aligned} \quad (I-6)$$

and from Equation 4-225

$$(\varphi_R)'[A]H\dot{p} = \{0\} \quad (I-7)$$

so that

$$[\Gamma][A]\dot{p} = [A]H\dot{p} \quad (I-8)$$

Then we can write Equation I-5 as

$$[A]\dot{p} = \{h\} - [\Gamma][G]H\dot{p} \quad (I-9)$$

and solve for the p_1 's

$$\dot{p} = [A]^{-1}(\{h\} - [\Gamma][G]H\dot{p}) \quad (I-10)$$

Contrails

In Equations 4-301, 4-302, and 4-303 the Ω 's were solved for, obtaining

$$\Omega_x = \frac{1}{\lambda} (\lambda_{yy} \lambda_{zz} - \lambda_{yz}^2) (H_x - 2 \xi \rho \dot{\xi} [G_{yz} H \dot{\rho} \dot{\xi}]) \quad (I-11)$$

$$+ \frac{1}{\lambda} (\lambda_{yz} \lambda_{xz} - \lambda_{xy} \lambda_{zz}) (H_y + 2 \xi \rho \dot{\xi} [G_{xz} H \dot{\rho} \dot{\xi}])$$

$$+ \frac{1}{\lambda} (\lambda_{xy} \lambda_{zz} - \lambda_{xz} \lambda_{yy}) (H_z - 2 \xi \rho \dot{\xi} [G_{xy} H \dot{\rho} \dot{\xi}])$$

(I-12)

$$\Omega_y = \frac{1}{\lambda} (\lambda_{yz} \lambda_{xz} - \lambda_{xy} \lambda_{zz}) (H_x - 2 \xi \rho \dot{\xi} [G_{yz} H \dot{\rho} \dot{\xi}])$$

$$+ \frac{1}{\lambda} (\lambda_{xx} \lambda_{zz} - \lambda_{xz}^2) (H_y + 2 \xi \rho \dot{\xi} [G_{xz} H \dot{\rho} \dot{\xi}])$$

$$+ \frac{1}{\lambda} (\lambda_{xy} \lambda_{xz} - \lambda_{yz} \lambda_{xx}) (H_z - 2 \xi \rho \dot{\xi} [G_{xy} H \dot{\rho} \dot{\xi}])$$

$$\Omega_z = \frac{1}{\lambda} (\lambda_{xy} \lambda_{zz} - \lambda_{xz} \lambda_{yy}) (H_x - 2 \xi \rho \dot{\xi} [G_{yz} H \dot{\rho} \dot{\xi}])$$

$$+ \frac{1}{\lambda} (\lambda_{xy} \lambda_{xz} - \lambda_{yz} \lambda_{xx}) (H_y + 2 \xi \rho \dot{\xi} [G_{xz} H \dot{\rho} \dot{\xi}])$$

$$+ \frac{1}{\lambda} (\lambda_{xz} \lambda_{yy} - \lambda_{yz}^2) (H_z - 2 \xi \rho \dot{\xi} [G_{xy} H \dot{\rho} \dot{\xi}])$$

(I-13)

where

$$\lambda = \lambda_{xx} \lambda_{yy} \lambda_{zz} + 2 \lambda_{xy} \lambda_{yz} \lambda_{xz} - \lambda_{xx} \lambda_{yz}^2 - \lambda_{yy} \lambda_{xz}^2 - \lambda_{zz} \lambda_{xy}^2 \quad (I-14)$$

2.0 EQUATIONS SOLVED BY THE ROUTINE

The input for the program is:

$${}^{N \times N} [A_{xx}], [A_{yy}], [A_{zz}], [A_{xy}], [A_{xz}], [A_{yz}]$$

$${}^{N \times N} [K]$$

$${}^{N \times N} [B]$$

$${}^{N \times 6} [\varphi_R]$$

and initial conditions:

$$\begin{aligned} & \{p(0)\} \\ & \{h(0)\} \\ & V_x(0), V_y(0), V_z(0) \\ & H_x(0), H_y(0), H_z(0) \end{aligned} \tag{I-15}$$

Preliminary calculations, internal to the program, are:

$$\begin{aligned} [A] &= [A_{xx}] + [A_{yy}] + [A_{zz}] \\ [\varphi_R]'[A][\varphi_R] &= \begin{bmatrix} M & 0 & 0 & & & \\ 0 & M & 0 & & & 0 \\ 0 & 0 & M & & & \\ & & & I_{xx} & -I_{xy} & -I_{xz} \\ & & & -I_{xy} & I_{yy} & -I_{yz} \\ & & & -I_{xz} & -I_{yz} & I_{zz} \end{bmatrix} \end{aligned} \tag{I-16}$$

Contrails

$$[\Gamma] = [1] - [A][\varphi_R]([\varphi_R]'[A][\varphi_R])^{-1}[\varphi_R]' \quad (\text{I-17})$$

$$[G_{xy}] = \frac{[A_{xy}] - [A_{xy}]'}{2}$$

$$[G_{xz}] = \frac{[A_{xz}] - [A_{xz}]'}{2}$$

$$[G_{yz}] = \frac{[A_{yz}] - [A_{yz}]'}{2}$$

$$[H_{xx}] = \frac{[A_{yy}] + [A_{zz}]}{2} \quad (\text{I-18})$$

$$[H_{yy}] = \frac{[A_{xx}] + [A_{zz}]}{2}$$

$$[H_{zz}] = \frac{[A_{xx}] + [A_{yy}]}{2}$$

$$[H_{xy}] = \frac{[A_{xy}] + [A_{xy}]'}{2}$$

$$[H_{xz}] = \frac{[A_{xz}] + [A_{xz}]'}{2}$$

$$[H_{yz}] = \frac{[A_{yz}] + [A_{yz}]'}{2} \quad (\text{I-19})$$

The equations to be integrated are

$$\frac{dV_x}{dt} = \Omega_z V_y - \Omega_y V_z + F_x/M \quad (\text{I-20})$$

$$\frac{dV_y}{dt} = \Omega_x V_z - \Omega_z V_x + F_y/M$$

Contrails

$$\frac{dV_x}{dt} = \Omega_y V_x - \Omega_x V_y + F_x / M$$

$$\frac{dH_x}{dt} = \Omega_z H_y - \Omega_y H_z + G_x$$

$$\frac{dH_y}{dt} = \Omega_x H_z - \Omega_z H_x + G_y$$

$$\frac{dH_z}{dt} = \Omega_y H_x - \Omega_x H_y + G_z$$

$$\dot{\mathbf{h}} = [\mathbf{A}]'(\mathbf{h}) - [\mathbf{r}][\mathbf{G}]\dot{\mathbf{p}}$$

(I-21)

$$\begin{aligned} \dot{\mathbf{h}} = & -[\mathbf{r}][\mathbf{G}]\dot{\mathbf{p}} + [\mathbf{r}][\mathbf{H}]\dot{\mathbf{p}} + [\mathbf{r}]\dot{\mathbf{K}} \\ & -[\mathbf{K}]\dot{\mathbf{p}} - [\mathbf{B}]\dot{\mathbf{p}} + \dot{\mathbf{P}} \end{aligned}$$

(I-22)

The following intermediate calculations are made at each integration step.

$$\begin{aligned} \lambda_{xx} &= I_{xx} + 2(\dot{\varphi}_R \dot{\varphi}_4' [A_{yz}] + \dot{\varphi}_R \dot{\varphi}_5' [A_{xz}])\dot{\mathbf{p}} + 2\dot{\mathbf{p}}\dot{\mathbf{p}}' [H_{xx}]\dot{\mathbf{p}} \\ \lambda_{xy} &= I_{xy} + 2\dot{\varphi}_R \dot{\varphi}_5' [A_{yz}]\dot{\mathbf{p}} - \dot{\mathbf{p}}\dot{\mathbf{p}}' [H_{xy}]\dot{\mathbf{p}} \\ \lambda_{xz} &= I_{xz} + 2\dot{\varphi}_R \dot{\varphi}_4' [A_{xy}]\dot{\mathbf{p}} - \dot{\mathbf{p}}\dot{\mathbf{p}}' [H_{xz}]\dot{\mathbf{p}} \\ \lambda_{yy} &= I_{yy} + 2(\dot{\varphi}_R \dot{\varphi}_6' [A_{xy}] + \dot{\varphi}_R \dot{\varphi}_5' [A_{xz}])\dot{\mathbf{p}} + 2\dot{\mathbf{p}}\dot{\mathbf{p}}' [H_{yy}]\dot{\mathbf{p}} \\ \lambda_{yz} &= -I_{yz} + 2\dot{\varphi}_R \dot{\varphi}_6' [A_{xz}]\dot{\mathbf{p}} - \dot{\mathbf{p}}\dot{\mathbf{p}}' [H_{yz}]\dot{\mathbf{p}} \\ \lambda_{zz} &= I_{zz} + 2(\dot{\varphi}_R \dot{\varphi}_6' [A_{xy}] + \dot{\varphi}_R \dot{\varphi}_4' [A_{yz}])\dot{\mathbf{p}} + 2\dot{\mathbf{p}}\dot{\mathbf{p}}' [H_{zz}]\dot{\mathbf{p}} \end{aligned}$$

(I-23)

Contrails

$$\lambda = \lambda_{xx}\lambda_{yy}\lambda_{zz} + 2\lambda_{xy}\lambda_{xz}\lambda_{yz} - \lambda_{xx}\lambda_{yz}^2 - \lambda_{yy}\lambda_{xz}^2 - \lambda_{zz}\lambda_{xy}^2 \quad (\text{I-24})$$

$$k_{xx} = (\lambda_{yy}\lambda_{zz} - \lambda_{yz}^2) / \lambda$$

$$k_{yy} = (\lambda_{xx}\lambda_{zz} - \lambda_{xz}^2) / \lambda$$

$$k_{zz} = (\lambda_{xx}\lambda_{yy} - \lambda_{xy}^2) / \lambda$$

$$k_{xz} = (\lambda_{xy}\lambda_{yz} - \lambda_{xz}\lambda_{yy}) / \lambda \quad (\text{I-25})$$

$$k_{xy} = (\lambda_{yz}\lambda_{xz} - \lambda_{xy}\lambda_{zz}) / \lambda$$

$$k_{yz} = (\lambda_{xy}\lambda_{xz} - \lambda_{yz}\lambda_{xx}) / \lambda$$

$$\begin{aligned} \Omega_x = & k_{xx}(H_x - 2\dot{\xi}\rho\dot{\xi}'[G_{yz}]\dot{\xi}\dot{\rho}\dot{\xi}) \\ & + k_{xy}(H_y + 2\dot{\xi}\rho\dot{\xi}'[G_{xz}]\dot{\xi}\dot{\rho}\dot{\xi}) \\ & + k_{xz}(H_z - 2\dot{\xi}\rho\dot{\xi}'[G_{xy}]\dot{\xi}\dot{\rho}\dot{\xi}) \end{aligned} \quad (\text{I-26})$$

$$\begin{aligned} \Omega_y = & k_{xy}(H_x - 2\dot{\xi}\rho\dot{\xi}'[G_{yz}]\dot{\xi}\dot{\rho}\dot{\xi}) \\ & + k_{yy}(H_y + 2\dot{\xi}\rho\dot{\xi}'[G_{xz}]\dot{\xi}\dot{\rho}\dot{\xi}) \\ & + k_{yz}(H_z - 2\dot{\xi}\rho\dot{\xi}'[G_{xy}]\dot{\xi}\dot{\rho}\dot{\xi}) \end{aligned} \quad (\text{I-27})$$

$$\begin{aligned} \Omega_z = & k_{xz}(H_x - 2\dot{\xi}\rho\dot{\xi}'[G_{yz}]\dot{\xi}\dot{\rho}\dot{\xi}) \\ & + k_{yz}(H_y + 2\dot{\xi}\rho\dot{\xi}'[G_{xz}]\dot{\xi}\dot{\rho}\dot{\xi}) \\ & + k_{zz}(H_z - 2\dot{\xi}\rho\dot{\xi}'[G_{xy}]\dot{\xi}\dot{\rho}\dot{\xi}) \end{aligned} \quad (\text{I-28})$$

Contrails

$$[G] = 2 (\Omega_x [G_{yz}] + \Omega_y [G_{xz}] - \Omega_z [G_{xy}]) \quad (I-29)$$

$$[H] = 2 \left(\Omega_x^2 [H_{xx}] + \Omega_y^2 [H_{yy}] + \Omega_z^2 [H_{zz}] - \Omega_x \Omega_y [H_{xy}] - \Omega_x \Omega_z [H_{xz}] - \Omega_y \Omega_z [H_{yz}] \right) \quad (I-30)$$

$$\begin{aligned} \{K\} = & (\Omega_y^2 + \Omega_z^2) [A_{xy}] \{\varphi_R\}_6 + 2 \Omega_x \Omega_y [A_{yz}] \{\varphi_R\}_5 \\ & + 2 \Omega_x \Omega_z [A_{xy}] \{\varphi_R\}_4 + (\Omega_x^2 + \Omega_z^2) [A_{yz}] \{\varphi_R\}_4 \\ & + 2 \Omega_y \Omega_z [A_{xz}] \{\varphi_R\}_6 + (\Omega_x^2 + \Omega_y^2) [A_{xz}] \{\varphi_R\}_5 \end{aligned} \quad (I-31)$$

$$\begin{bmatrix} F_x \\ F_y \\ F_z \\ G_x \\ G_y \\ G_z \end{bmatrix} = [\varphi_R] \{P\} \quad (I-32)$$

The generalized forces, P_1 , may be supplied as a table or generated by subroutines in the program.

The output is the time history of $V_x, V_y, V_z, \Omega_x, \Omega_y, \Omega_z$ and the generalized coordinates, P_1, P_2, \dots, P_N .

3.0 DESCRIPTION OF DIGITAL ROUTINE NO. LVV420 - PANDORA

The following is a description of the digital routine that has been coded to determine the motion and configuration for a general elastic body executing large "rigid-body" displacements. A description of the data, order in which data is presented to the routine, sample problems, listings of the coding, and core storage allocations are included.

The routine has been coded in 709/7090 FORTRAN II language and is compatible with the FORTRAN Monitor System for a machine with a minimum of 32,768 storage locations.

Integration of the differential equations in this program is accomplished by means of a four point Gill-Runge-Kutta numerical integration procedure (see Appendix VI) which is generally considered to have good convergence qualities. The equations of motion have been expressed in the Hamiltonian form which are first order and more amenable to solution by the Runge-Kutta scheme. This has resulted in streamlining the numerical problem as compared with the alternative of the Lagrangian approach. Lagrange's equations, which are second order, must be artificially reduced to a set of first order equations before the Runge-Kutta method can be applied. The symmetry and simplicity of the Hamiltonian equations is lost by this circuitous approach.

In order to achieve the capability of handling up to 30 elastic degrees of freedom, the problem of data handling has been optimized. Most of the matrices in the program are either symmetric ($a_{ij} = a_{ji}$) or antisymmetric ($a_{ij} = -a_{ji}$). Due to this fact, it was necessary to store only half of these matrices.

3.1 The Order in Which Data is Presented to the Machine

The data is read into the machine in the following order:

- (1) One IBM card of control numbers for the routine.
- (2) Two IBM cards of descriptive information about the run.
- (3) As many cards as necessary to read in the single parameters for the run.
- (4) As many cards as necessary to read in the initial conditions of the integration variables for the run.
- (5) As many cards as necessary to read in the blocks of parameters for the run.

There are two features of this routine which greatly minimize the effect of reading in information for parameter studies, etc. First, the machine initially sets to zero all the parameters. This means that if any parameters of the system are zero, they need not be read in since they are already zero in the computer. Second, parameters retain their values throughout the time the routine is in the computer except as modified by new values read in. Since this routine allows parameters to be read in selectively, for successive runs

Contrails

only values that change for that run need be read in. To accomplish this selectivity in reading data into the machine, it is necessary to make a one to one correspondence between parameters of the system and a subscripted symbol "p". Below is a list which defines this correspondence with typical consistent units of data in parenthesis.

- P(1) - Δt , integration step size (sec.)
- P(2) - t_{max} , total time for which motion is to be calculated (sec.)
- P(121) - P(150) - $\{P\}$, generalized forces (lb.)
- P(151) - P(330) - $[\phi_R]$, rigid body displacements (in.)
- P(331) - P(1230) - $[A_{xx}]$
- P(1231) - P(2130) - $[A_{yy}]$
- P(2131) - P(3030) - $[A_{zz}]$
- P(3031) - P(3930) - $[A_{yx}]$
- P(3931) - P(4830) - $[A_{zx}]$
- P(4831) - P(5730) - $[A_{zy}]$
- P(5731) - P(6630) - $[K]$, stiffness matrix, (lb./in.)
- P(6631) - P(7530) - $[B]$, damping matrix, (lb.-sec./in.)

inertia matrices (lb-sec.²/in.)

The following initial conditions are also supplied as parameters if unequal to zero or unchanged from the previous run.

- P(61) - P(90) - $p(0)$ generalized coordinates (in.)
- P(91) - P(120) - $h(0)$ generalized momenta (lb.-sec.)

The remaining initial conditions are entered in the same manner as the above "P" initial conditions, but have a correspondence to the subscripted symbol "FIRSTY", thus;

- FIRSTY(1) - t_0 , initial value of time (usually this is zero, hence it need not be read into the machine)(sec.)
- FIRSTY(2) - $V_x(0)$, initial value of c.g. velocity in the x direction (in./sec.)
- FIRSTY(3) - $V_y(0)$, initial value of c.g. velocity in the y direction (in./sec.)
- FIRSTY(4) - $V_z(0)$, initial value of c.g. velocity in the z direction (in./sec.)

Contrails

FIRSTY(5) - $H_x(0)$, initial value of angular momentum in the x direction
(lb.-sec.-in.)

FIRSTY(6) - $H_y(0)$, initial value of angular momentum in the y direction
(lb.-sec.-in.)

FIRSTY(7) - $H_z(0)$, initial value of angular momentum in the z direction
(lb.-sec.-in.)

As far as the machine is concerned it reads in values of the subscripted variables. There are two methods by which the computer reads in these values. The first method allows for a completely random selection of variables to be read in, for instance, P(17), P(15), P(23), P(2). The second method allows for selected blocks of successive parameters to be read in, or for selected parameters separated by equal numbers of parameters to be read in. For instance, this method could be used to read in P(3), P(4), P(5), P(6), and P(11), P(12), P(13), P(14), P(15), or to read in (P(6), P(9), P(12), P(15), P(18)). This method allows up to seven parameters to be read in on each IBM punched card, while the first method requires an IBM punched card for every parameter read in. A combination of the two methods may be used for reading data into the computer. The initial conditions which correspond to the subscripted symbol "FIRSTY" are read in exclusively by the first method.

3.2 Details of the Mechanics of Reading Data into the Computer

The first IBM punched card presented in the data contains the control numbers for the routine (see Figure 109). Seven of these are determined by the user, while the remaining must stay fixed as shown in Figure 109.

The control numbers are denoted and allocated columns on the first two cards as shown below.

IDENT - Card columns 1-5

NP - Card columns 6-10

NFIRST - Card columns 16-20

NPS - Card columns 36-40

NFORSP - Card columns 51-55

NFSKIP - Card columns 61-65

These numbers are never written with a decimal point and are always placed to the extreme right in their allotted number of columns.

IDENT - This number is "1" for the first run, "2" for the second run, etc., or any identification number that is desired.

NP - This number controls the reading in of data. NP equals the number of single parameter cards to be read in by the method previously described.

Contrails

NFIRST - This number controls the reading of initial conditions. NFIRST = 0 results in no new initial conditions being read in, while if it is desired to read in initial conditions, NFIRST equals the number of initial conditions to be read in.

NPS - NPS equals the number of generalized coordinates to be used in the calculation.

NFORSP - This integer selects the subroutine by which the generalized forces are to be calculated. Allowance has been made to include up to nine methods. At the present time, none have been coded, and the generalized forces are assumed to be zero or constant. This number must be supplied as an integer between "1" and "9".

NPT - This number controls the reading in of parameters by the block method. NPT equals the number of blocks of parameters to be read in by the method previously described.

NFSKIP - This number is used to indicate at what times it is desired to have results of the integration printed out. Noting that the computer prints out automatically at time = 0, NFSKIP is the number of integration steps minus "1" required to progress from the time of the last printout up to the time where the next printout is desired. For example, if the integration stepsize is 1 second and answers are desired at 0, 5, 10, 15 sec., etc., NFSKIP would equal 4. NFSKIP = 0 causes a printout for each integration step.

The second and third IBM punched cards allow descriptive material to be read into the machine which will later be printed out with the answers. Each card has columns 2 through 72 available for entering either alphabetic or numeric characters. It is necessary that cards 1, 2, and 3 always be supplied with each run. The cards following the first three depend upon the values of the control numbers, NP, NFIRS, and NPT, on the first card which is read in at the beginning of the run. To determine the cards that follow, first consider NP. If NP = 0, no parameters are to be read in. In NP = "m", there will be "m" separate parameter cards read in. Each parameter will have its own card. The form of the card will be as follows:

Card columns 1 through 5 will contain the number N (with no decimal point and placed to the extreme right of the field).

Card columns 6 through 20 (preferably 11 through 20) will contain the desired value of the Nth parameter P(N).

Card columns 21 through 80 are ignored by the computer. For convenience, descriptive material may be entered here for future reference.

There will be "m" of these parameter cards.

To determine the next cards to be read in, consider NFIRST. If NFIRST = L, there will be supplied "L" cards of the same format as the above NP parameter cards.

Contrails

The last cards to be read in are determined by NPT. If $NPT = 0$, the input data is complete and no additional cards need be supplied. If $NPT = "n"$, then "n" blocks of parameters will be read in. The first card in the block will contain three integer control numbers (written without decimal points): NP1 - card columns 1 through 5, NP2 - card columns 6-10, and NP3 - card columns 11 through 15. These control numbers tell the computer that the next card(s) will contain parameters P(NP1) through P(NP2) and that they should be read in in steps of NP3. The card(s) that follow will then contain the desired parameters. Each card must contain 7 parameters except the last card of the block which may contain from 1 to 7 parameters. The first 70 card columns are available for supplying parameters. Each parameter is allotted 10 card columns, hence, the first parameter entered on a card uses columns 1 through 10, the next, 11 through 20, etc. The numbers must have a decimal point. A parameter may be written down in either of two forms, decimal or exponential, i.e., the number 3562.2 may be entered on the IBM card either as card col.

```
1 2 3 4 5 6 7 8 9 10
3 5 2 6 . 2
```

or

```
3 . 5 2 6 2 + 3
```

In the last case, the "+" (or "-" in the case of a number less than one), is mandatory, and the exponent must occupy the far right hand column. To enter a block of parameters, suppose $NP1 = 8$, $NP2 = 16$, and $NP3 = 1$. The cards necessary to supply these parameters are

card col.	1 - 10	11 - 20	21 - 30	31 - 40	41 - 50	51 - 60	61 - 70
Card 1,	8 16	1					
Card 2,	P(8)	P(9)	P(10)	P(11)	P(12)	P(13)	P(14)
Card 3,	P(15)	P(16)					

Had NP3 equaled 2, the second card would be as shown below, and there would be no third card.

Card 2,	P(8)	P(10)	P(12)	P(14)	P(16)		
---------	------	-------	-------	-------	-------	--	--

There will be "n" cards of control numbers NP1, NP2, NP3, each followed by the card(s) of parameters dictated by the control numbers.

The blocks of parameters are the last cards to be read into the computer.

3.2.1 Mechanics of Entering Arrays

All matrices which are input data have a correspondence to the subscripted symbol "P". These arrays are arranged in storage in the manner dictated by a Fortran generated program¹. It is suggested that arrays be entered by the block parameter method for efficiency.

3.2.2 General Form of Data Sheets for Routine Pandora

Figure 109 depicts the general order and form in which data is presented to routine Pandora. It also indicates that the first 3 cards must always be presented for a run. Note that the first card (the integer-control card) has both integers and symbols denoted on it. The symbols denote those fields of the control card into which numbers can be entered at will by the user of the routine. Those fields which contain given numbers must retain these indicated values run after run.

¹ Reference Manual 709/7090 FORTRAN Programming System, C28-6054-2, IBM Corporation, 1961, p. 8 and p. 56.

LINE NO.	1	2	3	4	5	6	7	8	9	10	11	12	13	14	15	16	17	18	19	20	21	22	23	24	25	26	27	28	29	30	31	32	33	34	35	36	37	38	39	40	
CARD 1	IDENTIFY	NP	O	IFIRST	O	O	O	IPS	O	ONFORSE	NP1	O	ONTSKIP	O																											
CARD 2	ARBITRARY INFORMATION																																								
CARD 3	ARBITRARY INFORMATION																																								
1	IF NP IS NOT ZERO, THE FOLLOWING TYPE OF DATA SHOULD BE SUPPLIED NEXT.																																								
2	5	P(5)																																							
3	21	P(21)																																							
4	15	P(15)																																							
5	THE GENERAL FORM WILL BE																																								
6	M	IF NP ≠ K, THERE WILL BE 'K' OF THESE CARDS.																																							
7	IF NP1 IS NOT ZERO, THE FOLLOWING TYPE OF DATA SHOULD BE SUPPLIED NEXT.																																								
8	3	FIRSTY (3)																																							
9	THE GENERAL FORM WILL BE																																								
10	M	IF FIRST = L, THERE WILL BE 'L' OF THESE CARDS.																																							
11	IF NP1 IS NOT ZERO, DATA IN THE FOLLOWING BLOCK FORM SHOULD BE SUPPLIED NEXT.																																								
12	NP1	NP2	NP3																																						
13	P(NP1)	P(NP1+NP2)		P(NP1+2NP3)																																					
14	THE GENERAL FORM WILL BE																																								
15	IF NP1 ≠ M, THERE WILL BE 'M' BLOCKS OF THESE CARDS.																																								

FIGURE 109 FORM FOR PRESENTING DATA TO ROUTINE

Contrails

3.2.3 Core Storage Allocation

The following is a complete description of the core storage allocation for Routine PANDORA. This is included for use in possible program modification and for debugging. These variables which are input data are denoted by an asterisk.

3.2.3.1 Core Storage Allocations for Subscripted Variables

*P(61)	- PPO	P(12211)	- AZXF5	
*P(91)	- HHO	P(12241)	- AZXF6	
*P(121)	- PF	P(12271)	- AYXF4	
*P(151)	- FER	P(12301)	- AYXF6	
*P(331)	- AXX	P(12331)	- DK	
*Denotes input data	*P(1231)	- AYY	P(12361)	- HGAMGP
	*P(2131)	- AZZ	P(12856)	- GZY
	*P(3031)	- AYX	P(13321)	- GZX
	*P(3931)	- AZX	P(13786)	- GYX
	*P(4831)	- AZY	P(14251)	- HZY
	*P(5731)	- SX	P(14716)	- HZX
	*P(6631)	- B	P(15181)	- HYY
	P(7531)	- A	P(15646)	- HXX
	P(8431)	- AINV	P(16111)	- HYY
	P(9331)	- GAMG	P(16576)	- HZZ
	P(10231)	- GAMH	P(17401)	- G
	P(11131)	- WB	P(17506)	- H
	P(12031)	- PP	P(17971)	- F
	P(12061)	- HH	P(17977)	- FAF
	P(12091)	- PD	P(17983)	- FAFI
	P(12121)	- HD	P(17989)	- OUTP
	P(12151)	- AZYF4	P(20041)	- GAM
	P(12181)	- AZYF5	P(20941)	- FMESS

Contrails

3.2.3.2 Equivalent "P" Allocations for Data Entered in Array Form

First element of single subscripted variables:

PPO P(61)

HHO P(91)

PF P(121)

First element of each column of double subscripted variables:

Column	FER	AXX	AYY	AZZ	AYX	AZX	AZY	SK	B
1	151	331	1231	2131	3031	3931	4831	5731	6631
2	181	361	1261	2161	3061	3961	4861	5761	6661
3	211	391	1291	2191	3091	3991	4891	5791	6691
4	241	421	1321	2221	3121	4021	4921	5821	6721
5	271	451	1351	2251	3151	4051	4951	5851	6751
6	301	481	1381	2281	3181	4081	4981	5881	6781
7		511	1411	2311	3211	4111	5011	5911	6811
8		541	1441	2341	3241	4141	5041	5941	6841
9		571	1471	2371	3271	4171	5071	5971	6871
10		601	1501	2401	3301	4201	5101	6001	6901
11		631	1531	2431	3331	4231	5131	6031	6931
12		661	1561	2461	3361	4261	5161	6061	6961
13		691	1591	2491	3391	4291	5191	6091	6991
14		721	1621	2521	3421	4321	5221	6121	7021
15		751	1651	2551	3451	4351	5251	6151	7051
16		781	1681	2581	3481	4381	5281	6181	7081
17		811	1711	2611	3511	4411	5311	6211	7111
18		841	1741	2641	3541	4441	5341	6241	7141
19		871	1771	2671	3571	4471	5371	6271	7171
20		901	1801	2701	3601	4501	5401	6301	7201
21		931	1831	2731	3631	4531	5431	6331	7231
22		961	1861	2761	3661	4561	5461	6361	7261
23		991	1891	2791	3691	4591	5491	6391	7291
24			1021	1921	2821	3721	4621	5521	6421
25			1051	1951	2851	3751	4651	5551	6451
26			1081	1981	2881	3781	4681	5581	6481
27			1111	2011	2911	3811	4711	5611	6511
28			1141	2041	2941	3841	4741	5641	6541
29			1171	2071	2971	3871	4771	5671	6571
30			1201	2101	3001	3901	4801	5701	6601

Contrails

ROUTINE PANDORA

Integer 1 to 100

*Denotes input data

* 1 IDENT	34 NEOL(2)	67
* 2 NP	35 NEOL(3)	68
* 3 NINT = 0	36 NEOL(4)	69
* 4 NFIRST	37 NEOL(5)	70
* 5 NTABLE = 0	38 NEOL(6)	71
* 6 N = 0	39 NOUTP	72
* 7 NMORE = 0	40 NLO	73
* 8 NPS	41 LPRINT	74
* 9 NPASS = 0	42 NLINE	75
* 10 NFORSP	43 NSKIP	76
* 11 NPT	44 NPAGE	77
* 12 NTGR = 0	45 NFILE	78
* 13 NTSKIP	46 NPSL	79
14	47	80
15 NIND	48	81
16 NIND1	49	82
17 NIND2	50	83
18 NOTD	51	84
19 NOTD1	52	85
20 NOTD2	53	86
21	54	87
22	55	88
23	56	89
24	57	90
25	58	91
26	59	92
27	60	93
28	61	94
29	62	95
30	63	96
31	64	97
32	65	98
33 NEOL(1)	66	99
		00

Contrails

ROUTINE PANDORA

Parameter 1 to 100

*Denotes input data

* 1 DELTAT	34 CK	67
* 2 TIMAX	* 35 D	68
3	36 HMPGPX	69
4	37 HMPGPY	70
5	38 HMPGPZ	71
6	39	72
7	40	73
8	41	74
9	42	75
10	43	76
11 DLI1	44	77
12 DL22	45	78
13 DL33	46	79
14 DLI2	47	80
15 DLI3	48	81
16 DL23	49	82
17 DETERM	50	83
18 DLI11	51	84
19 DLI22	52	85
20 DLI33	53	86
21 DLI12	54	87
22 DLI13	55	88
23 DLI23	56	89
24 OMX	57	90
25 OMY	58	91
26 OMZ	59	92
27 OMXX	60	93
28 OMYX	61	94
29 OMZZ	62	95
30 OMXY	63	96
31 OMXZ	64	97
32 OMYZ	65	98
33 FNPS	66	99
		00

Contrails

ROUTINE PANDORA

Integration Variables

*Denotes input data

Y's	DYDX's	FIRSTY's
1 T	1 1.0	* 1 T(0)
2 VX	2 VXD	* 2 VXO
3 VY	3 VYD	* 3 VYO
4 VZ	4 VZD	* 4 VZO
5 HX	5 HXD	* 5 HXO
6 HY	6 HYD	* 6 HYO
7 HZ	7 HZD	* 7 HZO
8 PP(1)	8 PD(1)	8 PPO(1)
9 HH(1)	9 HD(1)	9 HHO(1)
10 PP(2)	10 PD(2)	10 PPO(2)
11 HH(2)	11 HD(2)	11 HHO(2)
12 PP(3)	12 PD(3)	12 PPO(3)
13 HH(3)	13 HD(3)	13 HHO(3)
14 PP(4)	14 PD(4)	14 PPO(4)
15 HH(4)	15 HD(4)	15 HHO(4)
16 PP(5)	16 PD(5)	16 PPO(5)
17 HH(5)	17 HD(5)	17 HHO(5)
18 PP(6)	18 PD(6)	18 PPO(6)
19 HH(6)	19 HD(6)	19 HHO(6)
20 PP(7)	20 PD(7)	20 PPO(7)
21 HH(7)	21 HD(7)	21 HHO(7)
22 PP(8)	22 PD(8)	22 PPO(8)
23 HH(8)	23 HD(8)	23 HHO(8)
24 PP(9)	24 PD(9)	24 PPO(9)
25 HH(9)	25 HD(9)	25 HHO(9)
26 PP(10)	26 PD(10)	26 PPO(10)
27 HH(10)	27 HD(10)	27 HHO(10)
28 PP(11)	28 PD(11)	28 PPO(11)
29 HH(11)	29 HD(11)	29 HHO(11)
30 PP(12)	30 PD(12)	30 PPO(12)
31 HH(12)	31 HD(12)	31 HHO(12)
32 PP(13)	32 PD(13)	32 PPO(13)
33 HH(13)	33 HD(13)	33 HHO(13)
34 PP(14)	34 PD(14)	34 PPO(14)

Contrails

ROUTINE PANDORA

Integration Variables

Y's	DYDX's	FIRSTY's
35 HH(14)	35 HD(14)	35 HHO(14)
36 PP(15)	36 PD(15)	36 PPO(15)
37 HH(15)	37 HD(15)	37 HHO(15)
38 PP(16)	38 PD(16)	38 PPO(16)
39 HH(16)	39 HD(16)	39 HHO(16)
40 PP(17)	40 PD(17)	40 PPO(17)
41 HH(17)	41 HD(17)	41 HHO(17)
42 PP(18)	42 PD(18)	42 PPO(18)
43 HH(18)	43 HD(18)	43 HHO(18)
44 PP(19)	44 PD(19)	44 PPO(19)
45 HH(19)	45 HD(19)	45 HHO(19)
46 PP(20)	46 PD(20)	46 PPO(20)
47 HH(20)	47 HD(20)	47 HHO(20)
48 PP(21)	48 PD(21)	48 PPO(21)
49 HH(21)	49 HD(21)	49 HHO(21)
50 PP(22)	50 PD(22)	50 PPO(22)
51 HH(22)	51 HD(22)	51 HHO(22)
52 PP(23)	52 PD(23)	52 PPO(23)
53 HH(23)	53 HD(23)	53 HHO(23)
54 PP(24)	54 PD(24)	54 PPO(24)
55 HH(24)	55 HD(24)	55 HHO(24)
56 PP(25)	56 PD(25)	56 PPO(25)
57 HH(25)	57 HD(25)	57 HHO(25)
58 PP(26)	58 PD(26)	58 PPO(26)
59 HH(26)	59 HD(26)	59 HHO(26)
60 PP(27)	60 PD(27)	60 PPO(27)
61 HH(27)	61 HD(27)	61 HHO(27)
62 PP(28)	62 PD(28)	62 PPO(28)
63 HH(28)	63 HD(28)	63 HHO(28)
64 PP(29)	64 PD(29)	64 PPO(29)
65 HH(29)	65 HD(29)	65 HHO(29)
66 PP(30)	66 PD(30)	66 PPO(30)
67 HH(30)	67 HD(30)	67 HHO(30)
68	68	68

3.2.4 Source Program Listings

The following is a complete set of listings of the main program and sub-routines. This can be useful in debugging and in program modification. It should be noted that two subroutines are included which have not previously been discussed. These are subroutine TAPEIN and subroutine FORCE1.

Subroutine TAPEIN was coded to allow the user to enter large matrices by means of a special tape input. These matrices were previously computed and written on the tape to be used as input to PANDORA. To use the tape input method at various computing facilities, it will probably be necessary to re-code the subroutine to allow for inconsistencies between systems.

Subroutine FORCE1 was coded to calculate the generalized forces due to a gust. It is of a very specialized nature. For this reason, the option NFORSP = 1 will not be used in normal operation of routine PANDORA.

TABLE 13
FORTRAN SOURCE PROGRAM LISTINGS OF ROUTINE "PANDORA"

```
* LIST
* SYMBOL TABLE
CHAIN-R
      COMMON VAR
      DIMENSION VAR(24000),DYDX(75)
      EQUIVALENCE (VAR(76),DYDX(1))
      DO 20 I = 1,24000
      VAR(I) = 0.0
      DYDX(1) = 1.0
      CALL RK
      END
0011
```

Contrails

* LIST
* SYMBOL TABLE
CINPUT

```
          SUBROUTINE INPUT
          COMMON VAR
          DIMENSION VAR(24000),P(23400),Y(75),NTEGER(225),
1  Q(75),FIRSTY(75),NT(30),NT1(30),NT2(30)
          EQUIVALENCE (VAR(1),Y(1)),(VAR(376),NTEGER(1)),
1  (VAR(601),P(1)),(VAR(151),Q(1)),(VAR(226),FIRSTY(1)),
2  (NTEGER(101),NT(1)),(NTEGER(131),NT1(1)),(NTEGER(161),NT2(1)),
3  (NTEGER(2),NP),(NTEGER(3),NINT),(NTEGER(4),NFIRST),
4  (NTEGER(5),NTABLE),(NTEGER(7),NMORE),(NTEGER(11),NPT),
5  (NTEGER(12),NCR),(NTEGER(13),NTSKIP),(NTEGER(44),NPAGE),
6  (NTEGER(6),N)
          EQUIVALENCE (NTEGER(15),NIND),(NTEGER(16),NIND1),
1  (NTEGER(17),NIND2)
C      SET THE PAGE NUMBER FOR THE FIRST PAGE.
20     NPAGE = 0
C      READ CONTROL NUMBERS INTO THE PROBLEM.
30     READ INPUT TAPE 5,30, (NTEGER(I), I=1,14)
40     FORMAT (14I5)
50     IF (NMORE) 60,60,50
60     READ INPUT TAPE 5,30, (NTEGER(I), I=15,NMORE)
C      PLACE HEADING AT TOP OF WRITE OUT.
70     CALL PAGEHD
C      READ AND WRITE TWO CARDS OF ARBITRARY RUN INFORMATION.
80     READ INPUT TAPE 5,80
90     FORMAT (72H
1     /72H
2     )
C      WRITE OUTPUT TAPE 6,80
C      CHECK FOR FLOATING POINT PARAMETER ENTRY AND THEN MAKE ENTRY
C      ACCORDING TO SINGLE PARAMETER READ IN METHOD (TYPE A ENTRY)
100    IF (NP) 150,150,110
110    DO 140 J = 1,NP
120    READ INPUT TAPE 5,130,I,(P(I))
130    FORMAT (I5,E15.7)
140    CONTINUE
C      CHECK FOR FIXED POINT NUMBER ENTRY AND THEN MAKE ENTRY
C      ACCORDING TO SINGLE INTEGER READ IN METHOD (TYPE B ENTRY)
150    IF (NINT) 200,200,160
160    DO 190 K = 1,NINT
170    READ INPUT TAPE 5,180,K,(NTEGER(I))
180    FORMAT (I5,I15)
190    CONTINUE
C      CHECK FOR NEW INITIAL CONDITIONS TO BE READ INTO THE PROBLEM
C      AND READ IN ACCORDING TO PRESCRIBED FORMAT (TYPE C ENTRY)
200    IF (NFIRST) 242,242,210
210    DO 240 L = 1,NFIRST
220    READ INPUT TAPE 5,230,I,(FIRSTY(I))
230    FORMAT (I5,E15.7)
240    CONTINUE
242    IF (NPT) 250,250,244
244    DO 248 I=1,NPT
246    READ INPUT TAPE 5,30,NP1,NP2,NP3
248    READ INPUT TAPE 5,360,(P(J),J=NP1,NP2,NP3)
C      CHECK IF TABLE ENTRIES ARE TO BE MADE AND READ IN TABLE ENTRIES
C      ACCORDING TO PRESCRIBED INPUTS (TYPE D ENTRY)
250    IF (NTABLE) 380,380,260
260    NT1(1) = NCR
270    DO 370 M = 1,NTABLE
280    IF (NT(M)) 290,370,310
290    NT1(M+1) = NT1(M)
```

Contrails

```
300          GO TO 370
310          NT1(M+1) = NT1(M) + NT(M)
320          NT2(M) = NT1(M) - 1 + NT(M)
330          NT11 = NT1(M)
340          NT12 = NT2(M)
350          READ INPUT TAPE 5,360,(P(N),N=NT11,NT12)
360          FORMAT (7E10.7)
370          CONTINUE
C          CALL IN INPUT DATA WRITING ROUTINE
380          CALL INAID
C          ZERO THE Q AND SET THE Y TO INITIAL VALUES
390          DO 420 N1 = 1,N
400          Q(N1) = 0.0
410          Y(N1) = FIRSTY(N1)
420          CONTINUE
430          IF(NIND) 450,450,440
440          CALL PDUMP (VAR,VAR(150),1,VAR(226),VAR(300),1,
1 NTEGER,NTEGER(46),2,P,P(7530),1)
450          NTEGER(42) = 0
460          RETURN
          END
0084
```

Contrails

* LIST
* SYMBOL TABLE
CTAPEIN

```
          SUBROUTINE TAPEIN  
          COMMON VAR  
          DIMENSION VAR(24000),P(23400),NTEGER(225)  
          EQUIVALENCE (VAR(601),P(1)),(P(34),CK),  
1 (VAR(376),NTEGER(1)),(NTEGER(45),NFILE)  
10          NFILE = NFILE  
20          IF (NFILE) 40,30,40  
30          CALL FWDPS (9,1)  
40          CALL RDTB (9,CK,P(6631),900,P(5731),900,P(4831),900,  
1 P(3931),900,P(3031),900,P(2131),900,P(1231),900,P(331),900,  
2 P(151),180)  
50          NFILE = 1  
60          RETURN  
          END  
0017
```

Contrails

* LIST
* SYMBOL TABLE
CINAID

```

SUBROUTINE INAID
COMMON VAR
DIMENSION VAR(24000),P(23400),NTEGER(225),AYX(30,30),
1 AZX(30,30),AZY(30,30),PP(30),HH(30),AZYF4(30),AZYF5(30),
2 AZXF5(30),AZXF6(30),AYXF4(30),AYXF6(30),          GZY(465),
3 GZX(465),GYX(465),HZY(465),HZX(465),HYX(465),HXX(465),HYY(465),
4 HZZ(465),FAF(6),GAM(30,30),FMESS(30,30)
EQUIVALENCE (P(20041),GAM(1)),(P(20941),FMESS(1))
EQUIVALENCE (VAR(376),NTEGER(1)),(VAR(601),P(1)),
1 (P(3031),AYX(1)),(P(3931),AZX(1)),(P(4831),AZY(1)),
2 (P(12031),PP(1)),(P(12061),HH(1)),(P(12151),AZYF4(1)),
3 (P(12181),AZYF5(1)),(P(12211),AZXF5(1)),(P(12241),AZXF6(1)),
4 (P(12271),AYXF4(1)),(P(12301),AYXF6(1)),(P(35),D),
5 (P(12856),GZY(1)),(P(13321),GZX(1)),(P(13786),GYX(1)),
6 (P(14251),HZY(1)),(P(14716),HZX(1)),(P(15181),HYX(1)),
7 (P(15646),HXX(1)),(P(16111),HYY(1)),(P(16576),HZZ(1)),
8 (P(17977),FAF(1)),(P(33),FNPS),(NTEGER(8),NPS),(NTEGER(46),NPSSL)
DIMENSION FIRSTY(75),PPO(30),HHO(30),FER(30,6),
1 AXX(30,30),AYY(30,30),AZZ(30,30),AINV(30,30),WB(30,30),A(30,30),
2 FAFI(6),E(30),X(30,30),FER1(30),FER2(30),FER3(30),FER4(30),
3 FER5(30),FER6(30),NEOL(6)
EQUIVALENCE (VAR(226),FIRSTY(1)),(P(61),PPO(1)),
1 (P(91),HHO(1)),(P(151),FER(1)),(P(331),AXX(1)),(P(1231),AYY(1)),
2 (P(2131),AZZ(1)),(P(7531),A(1)),(P(8431),AINV(1)),(AINV,X),
3 (P(11131),WB(1)),(P(17983),FAFI(1)),(FER(1),FER1(1)),
4 (FER(31),FER2(1)),(FER(61),FER3(1)),(FER(91),FER4(1)),
5 (FER(121),FER5(1)),(FER(151),FER6(1)),(NTEGER(9),NPASS),
6 (NTEGER(33),NEOL(1)),(NTEGER(39),NOUTP),(NTEGER(6),N)
C DETERMINE IF PASTRAN TAPE IS TO BE READ
10 IF (NPASS) 30,30,20
20 CALL TAPEIN
C CALCULATE MASS AND MOMENTS OF INERTIA
30 DO 50 I=1,NPS
40 DO 50 J=1,NPS
50 A(I,J) = AXX(I,J)+AYY(I,J)+AZZ(I,J)
60 DO 110 I=1,6
70 FAF(I) = 0.0
80 DO 100 J=1,NPS
90 DO 100 K=1,NPS
100 FAF(I) = FAF(I) + FER(J,I)*A(J,K)*FER(K,I)
110 FAFI(I) = 1.0/FAF(I)
120 DO 160 I=1,NPS
130 DO 160 J=1,NPS
140 FMESS(I,J) = 0.0
150 DO 160 K=1,6
160 FMESS(I,J) = FMESS(I,J) + FER(I,K)*FAFI(K)*FER(J,K)
C CALCULATE GAMMA MATRIX
170 DO 200 I=1,NPS
180 DO 200 J =1,NPS
190 IF (I=J) 192,196,192
192 GAM(I,J) = 0.0
194 GO TO 198
196 GAM(I,J) = 1.0
198 DO 200 K=1,NPS
200 GAM(I,J) = GAM(I,J) - A(I,K)*FMESS(K,J)
C SET UP LOOP FOR CALCULATING TRIANGULAR MATRICES
201 IF (NTEGER(14)) 202,202,430
202 DO 420 I=1,NPS
204 DO 290 J=I,NPS
206 L = (J*(J-1))/2+I

```

Contrails

```
C      CALCULATE G AND H TRIANGULAR MATRIX
210      GZY(L) = (AZY(I,J)-AZY(J,I))*0.5
220      GZX(L) = (AZX(I,J)-AZX(J,I))*0.5
230      GYX(L) = (AYX(I,J)-AYX(J,I))*0.5
240      HZY(L) = (AZY(I,J)+AZY(J,I))*0.5
250      HZX(L) = (AZX(I,J)+AZX(J,I))*0.5
260      HYX(L) = (AYX(I,J)+AYX(J,I))*0.5
270      HXX(L) = (AYY(I,J)+AZZ(I,J))*0.5
280      HYY(L) = (AXX(I,J)+AZZ(I,J))*0.5
290      HZZ(L) = (AXX(I,J)+AYY(I,J))*0.5
C      CALCULATE APHI MATRICES
300      AZYF4(I) = 0.0
310      AZYF5(I) = 0.0
320      AZXF5(I) = 0.0
330      AZXF6(I) = 0.0
340      AYXF4(I) = 0.0
350      AYXF6(I) = 0.0
360      DO 420 JJ=1,NPS
370      AZYF4(I) = AZYF4(I) + AZY(JJ,I)*FER4(JJ)
380      AZYF5(I) = AZYF5(I) + AZY(JJ,I)*FER5(JJ)
390      AZXF5(I) = AZXF5(I) + AZX(I,JJ)*FER5(JJ)
400      AZXF6(I) = AZXF6(I) + AZX(I,JJ)*FER6(JJ)
410      AYXF4(I) = AYXF4(I) + AYX(JJ,I)*FER4(JJ)
420      AYXF6(I) = AYXF6(I) + AYX(JJ,I)*FER6(JJ)
C      INVERT MASS MATRIX
430      DO 470 I=1,NPS
440      DO 460 J=1,NPS
450      WB(I,J) = 0.0
460      AINV(I,J) = A(I,J)
470      WB(I,I) = 1.0
490      M = XSIMEQF(30,NPS,NPS,AINV,WB,D,E)
500      GO TO (570,510,540),M
510      WRITE OUTPUT TAPE 6,520
520      FORMAT (46H UNDER/OVERFLOW IN MASS MATRIX INVERSION)
530      CALL RK
540      WRITE OUTPUT TAPE 6,550
550      FORMAT (30H MASS MATRIX IS SINGULAR)
560      CALL RK
570      N = 7 + 2*NPS
580      DO 640 I=1,NPS
590      J = 6 + I*2
600      K = 7 + I*2
C      SET P AND H EQUAL TO INITIAL CONDITIONS
610      PP(I) = PPO(I)
620      HH(I) = HHO(I)
C      SET P AND H EQUAL TO PROPER INTEGRATION VARIABLES
630      FIRSTY(J) = PP(I)
640      FIRSTY(K) = HH(I)
650      NPSL = (NPS*(NPS+1))/2
660      FNPS = FLOATF(NPS)
670      NOUTP = (NPS-1)/5+1
680      DO 690 I=1,NOUTP
690      NEOL(I) = 6
700      NEOL(NOUTP) = NPS - 5*NOUTP + 6
710      RETURN
      END
0119
```

Contrails

* LIST
* SYMBOL TABLE
CDYDXS

```

SUBROUTINE DYDXS
COMMON VAR
DIMENSION VAR(24000),P(23400),NTEGER(225),AYX(30,30),
1 AZX(30,30),AZY(30,30),PP(30),HH(30),AZYF4(30),AZYF5(30),
2 AZXF5(30),AZXF6(30),AYXF4(30),AYXF6(30),GZY(465),
3 GZX(465),GYX(465),HZY(465),HZX(465),HYX(465),HXX(465),HYY(465),
4 HZZ(465),FAF(6),GAM(30,30),FMESS(30,30)
EQUIVALENCE (P(20041),GAM(1)),(P(20941),FMESS(1))
EQUIVALENCE (VAR(376),NTEGER(1)),(VAR(601),P(1)),
1 (P(3031),AYX(1)),(P(3931),AZX(1)),(P(4831),AZY(1)),
2 (P(12031),PP(1)),(P(12061),HH(1)),(P(12151),AZYF4(1)),
3 (P(12181),AZYF5(1)),(P(12211),AZXF5(1)),(P(12241),AZXF6(1)),
4 (P(12271),AYXF4(1)),(P(12301),AYXF6(1)),
5 (P(12856),GZY(1)),(P(13321),GZX(1)),(P(13786),GYX(1)),
6 (P(14251),HZY(1)),(P(14716),HZX(1)),(P(15181),HYX(1)),
7 (P(15646),HXX(1)),(P(16111),HYY(1)),(P(16576),HZZ(1)),
8 (P(17977),FAF(1)),(P(33),FNPS),(NTEGER(8),NPS),(NTEGER(46),NPSL)
DIMENSION Y(75),DYDX(75),PF(30),SK(30,30),B(30,30),
1 GAMG(30,30),GAMH(30,30),PD(30),HD(30),DK(30),HGAMGP(30),G(465),
2 H(465),F(6),AINV(30,30),FER(30,6)
EQUIVALENCE (VAR(1),Y(1)),(VAR(76),DYDX(1)),
1 (P(121),PF(1)),(P(5731),SK(1)),(P(6631),B(1)),(P(9331),GAMG(1)),
2 (P(10231),GAMH(1)),(P(12091),PD(1)),(P(12121),HD(1)),
3 (P(12331),DK(1)),(P(12361),HGAMGP(1)),(P(17041),G(1)),
4 (P(17506),H(1)),(P(17971),F(1)),(FAF(3),CM),(FAF(4),CIXX),
5 (FAF(5),CIYY),(FAF(6),CIZZ),(P(11),DL11),(P(12),DL22),
6 (P(13),DL33),(P(14),DL12),(P(15),DL13),(P(16),DL23),
7 (P(17),DETERM),(P(18),DLI11),(P(19),DLI22),(P(20),DLI33),
8 (P(21),DLI12),(P(22),DLI13),(P(23),DLI23),
9 (P(24),OMX),(P(25),OMY),(P(26),OMZ),(P(27),OMXX),(P(28),OMYY)
EQUIVALENCE (P(29),OMZZ),(P(30),OMXY),(P(31),OMXZ),
1 (P(32),OMYZ),(Y(2),VX),(Y(3),VY),(Y(4),VZ),(Y(5),HX),(Y(6),HY),
2 (Y(7),HZ),(DYDX(2),VXD),(DYDX(3),VYD),(DYDX(4),VZD),
3 (DYDX(5),HXD),(DYDX(6),HYD),(DYDX(7),HZD),(P(8431),AINV(1)),
4 (P(151),FER(1))
EQUIVALENCE (P(36),HMPGPX),(P(37),HMPGPY),
1 (P(38),HMPGPZ)
C DETERMINE P AND H FROM INTEGRATION VARIABLES
10 DO 50 I=1,NPS
20 J = 6+I*2
30 K = 7+I*2
40 PP(I) = Y(J)
50 HH(I) = Y(K)
C CALCULATE TERMS IN LAMBDA MATRIX
60 DL11 = CIXX
70 DL22 = CIYY
80 DL33 = CIZZ
90 DL12 = 0.0
100 DL13 = 0.0
110 DL23 = 0.0
112 HMPGPX = HX
114 HMPGPY = HY
116 HMPGPZ = HZ
118 IF (NTEGER(14)) 120,120,240
120 DO 230 I=1,NPS
130 DO 230 J=1,NPS
140 IF (I-J) 150,150,170
150 L = (J*(J-1))/2+1
155 C = 1.0
160 GO TO 172

```

Contrails

```

170             L = (I*(I-1))/2+J
171             C = -1.0
172             HMPGPX = HMPGPX + 2.0*C*PP(I)*GZY(L)*PD(J)
174             HMPGPY = HMPGPY - 2.0*C*PP(I)*GZX(L)*PD(J)
176             HMPGPZ = HMPGPZ + 2.0*C*PP(I)*GYX(L)*PD(J)
180             DL11 = DL11+(2.0/FNPS)*(AZYF4(I)+AZXF5(I))*PP(I)
1 + PP(I)*HXX(L)*PP(J)*2.0
190             DL22 = DL22+(2.0/FNPS)*(AYXF6(I)+AZXF5(I))*PP(I)
1 + PP(I)*HYY(L)*PP(J)*2.0
200             DL33 = DL33+(2.0/FNPS)*(AYXF6(I)+AZYF4(I))*PP(I)
1 + PP(I)*HZZ(L)*PP(J)*2.0
210             DL12 = DL12+(2.0/FNPS)*AZYF5(I)*PP(I)
1 - PP(I)*AYX(I,J)*PP(J)
220             DL13 = DL13+(2.0/FNPS)*AYXF4(I)*PP(I)
1 - PP(I)*AZX(I,J)*PP(J)
230             DL23 = DL23+(2.0/FNPS)*AZXF6(I)*PP(I)
1 - PP(I)*AZY(I,J)*PP(J)
C             CALCULATE TERMS IN INVERSE LAMBDA MATRIX
240             DETERM = DL11*DL22*DL33 + DL12*DL13*DL23*2.0
1 - (DL11*DL23*DL23 + DL22*DL13*DL13 + DL33*DL12*DL12)
250             DLI11 = (DL22*DL33 - DL23*DL23)/DETERM
260             DLI22 = (DL11*DL33 - DL13*DL13)/DETERM
270             DLI33 = (DL11*DL22 - DL12*DL12)/DETERM
280             DLI12 = (DL23*DL13 - DL12*DL33)/DETERM
290             DLI13 = (DL12*DL23 - DL13*DL22)/DETERM
300             DLI23 = (DL12*DL13 - DL23*DL11)/DETERM
C             CALCULATE OMEGA TERMS
310             OMX = HMPGPX*DLI11 + HMPGPY*DLI12 + HMPGPZ*DLI13
320             OMY = HMPGPX*DLI12 + HMPGPY*DLI22 + HMPGPZ*DLI23
330             OMZ = HMPGPX*DLI13 + HMPGPY*DLI23 + HMPGPZ*DLI33
340             OMXX = OMX * OMX
350             OMYY = OMY * OMY
360             OMZZ = OMZ * OMZ
370             OMXY = OMX * OMY
380             OMXZ = OMX * OMZ
390             OMYZ = OMY * OMZ
C             CALL SUBROUTINE WHICH DETERMINES METHOD FOR FORCE CALCULATIONS
400             CALL FORSEL
410             DO 440 I=1,6
420             F(I) = 0.0
430             DO 440 J=1,NPS
440             F(I) = F(I) + FER(J,I)*PP(J)
C             CALCULATE DERIVATIVES OF VX,VY,VZ,HX,HY,HZ
450             VXD = OMZ*VY - OMY*VZ + F(1)/CM
460             VYD = OMX*VZ - OMZ*VX + F(2)/CM
470             VZD = OMY*VX - OMX*VY + F(3)/CM
480             HXD = OMZ*HY - OMY*HZ + F(4)
490             HYD = OMX*HZ - OMZ*HX + F(5)
500             HZD = OMY*HX - OMX*HY + F(6)
C             CALCULATE G AND H TRIANGULAR MATRICES
505             IF (INTEGER(14)) 510,510,700
510             DO 530 L=1,NPSL
520             G(L) = (OMX*GZY(L) - OMY*GZX(L) + OMZ*GYX(L))*2.0
530             H(L) = (OMXX*HXX(L) + OMYY*HYY(L) + OMZZ*HZZ(L)
1 - OMXY*HYX(L) - OMYZ*HZY(L) - OMXZ*HZX(L))*2.0
C             CALCULATE GAMMA TIMES G,GAMMA TIMES H, AND K MATRICES
540             DO 690 I=1,NPS
550             DO 680 J=1,NPS
560             GAMG(I,J) = 0.0
570             GAMH(I,J) = 0.0
580             DO 680 K=1,NPS
630             IF (K-J) 640,640,660
640             L2 = (J*(J-1))/2+K

```

Contrails

```
645          C = 1.0
650          GO TO 670
660          L2 = (K*(K-1))/2+J
665          C = -1.0
670          GAMG(I,J) = GAMG(I,J) + C*GAM(I,K)*G(L2)
680          GAMH(I,J) = GAMH(I,J) + GAM(I,K)*H(L2)
690          DK(I) = (OMXX+OMZZ)*AZYF4(I) + (OMXX+OMYY)*AZXF5(I)
1          + (OMYY+OMZZ)*AYXF6(I) + 2.0*(OMXZ*AYXF4(I) + OMXY*AZYF5(I)
2          + OMYZ*AZXF6(I))
C          CALCULATE H MINUS GAMMA TIMES G TIMES PF
700          DO 735 I=1,NPS
710          HGAMGP(I) = HH(I)
715          IF (NTEGER(14)) 720,720,735
720          DO 730 J=1,NPS
730          HGAMGP(I) = HGAMGP(I)-GAMG(I,J)*PP(J)
735          CONTINUE
C          CALCULATE DERIVATIVES OF P
740          DO 850 I=1,NPS
750          PD(I) = 0.0
760          HD(I) = 0.0
770          DO 830 J=1,NPS
780          PD(I) = PD(I) + AINV(I,J)*HGAMGP(J)
830          HD(I) = HD(I) + GAM(I,J)*(DK(J)+PF(J))
C          SET P EQUAL TO PROPER INTEGRATION VARIABLE
840          K = 6+I*2
850          DYDX(K) = PD(I)
860          DO 900 I=1,NPS
C          CALCULATE DERIVATIVES OF H
870          DO 880 J=1,NPS
880          HD(I) = HD(I) + (GAMH(I,J)-SK(I,J))*PP(J)
1          + (GAMG(I,J)+B(I,J))*PD(J)
C          SET H EQUAL TO PROPER INTEGRATION VARIABLE
890          K = 7+I*2
900          DYDX(K) = HD(I)
910          RETURN
          END
0162
```

Contrails

* LIST
* SYMBOL TABLE
CRK

```
      SURROUTINE RK  
      COMMON VAP  
      DIMENSION VAR(24000),DYDX(75),Y(75),Q(75),O(75),  
1 NTEGER(225),P(23400)  
      EQUIVALENCE (VAR(1),Y(1)),(VAR(76),DYDX(1)),  
1 (VAR(151),Q(1)),(VAR(301),O(1)),(VAR(376),NTEGER(1)),  
2 (VAR(501),P(1)),(NTEGER(6),N)  
C      LOAD INPUT DATA INTO MACHINE.  
10      CALL INPUT  
C      CALCULATE THE DELTAY(J) AT Y(1) = 0.0.  
20      CALL DYDXS  
30      DO 40 I = 1,N  
40      O(I) = DYDX(I)*P(I)  
C      DETERMINE THE OUTPUT OF THE INTEGRATION.  
50      CALL OUTPUT  
C      CALCULATE THE Y(J) AT Y(1) = 0.0.  
60      DO 90 J = 1,N  
70      R = .5*(O(J) - O(J))  
80      Y(J) = Y(J) + R  
90      O(J) = O(J) + 3.0*R - .5*O(J)  
C      CALCULATE THE DELTAY(J) AT Y(1) = HALF STEP SIZE.  
100     CALL DYDXS  
110     DO 120 I = 1,N  
120     O(I) = DYDX(I)*P(I)  
C      CALCULATE THE Y(J) AT Y(1) = HALF STEP SIZE.  
130     DO 160 J = 1,N  
140     R = .222803219*(O(J) - O(J))  
150     Y(J) = Y(J) + R  
160     O(J) = O(J) + 3.0*R - .222803219*O(J)  
C      CALCULATE THE DELTAY(J) AT Y(1) = HALF STEP SIZE AGAIN.  
170     CALL DYDXS  
180     DO 190 I = 1,N  
190     O(I) = DYDX(I)*P(I)  
C      CALCULATE THE Y(J) AT Y(1) = HALF STEP SIZE AGAIN.  
200     DO 230 J = 1,N  
210     R = 1.70710573*(O(J) - O(J))  
220     Y(J) = Y(J) + R  
230     O(J) = O(J) + 3.0*R - 1.70710573*O(J)  
C      CALCULATE THE DELTAY(J) AT Y(1) = STEP SIZE.  
240     CALL DYDXS  
250     DO 260 I = 1,N  
260     O(I) = DYDX(I)*P(I)  
C      CALCULATE THE Y(J) AT Y(1) = STEP SIZE.
```

Contrails

```
270          DO 300 J = 1,N
280          R = .1666666667*(D(J) - 2.0*Q(J))
290          Y(J) = Y(J) + R
300          Q(J) = Q(J) + 3.0*R - .5*D(J)
C          PROCEED TO THE NEXT INTEGRATION STEP.
310          NGO = 1
320          GO TO (20,330),NGO
330          RETURN
          END
2055
```

Contrails

* LIST
* SYMBOL TABLE
COUTAID

```
      SUBROUTINE OUTAID  
      COMMON VAR  
      DIMENSION VAR(24000),P(23400),NTEGER(225),  
1  OUTP(6,57,6),NEOL(6),Y(75),DYDX(75),PP(30)  
      EQUIVALENCE (VAR(601),P(1)),(VAR(376),NTEGER(1)),  
1  (P(17989),OUTP(1)),(NTEGER(33),NEOL(1)),(NTEGER(39),NOUTP),  
2  (NTEGER(40),NLO),(NTEGER(42),NLINE),(Y(1),T),(Y(2),VX),  
3  (Y(3),VY),(Y(4),VZ),(DYDX(2),VXD),(DYDX(3),VYD),(DYDX(4),VZD),  
4  (P(24),OMX),(P(25),OMY),(P(26),OMZ),(P(12031),PP(1)),  
5  (VAR(1),Y(1)),(VAR(76),DYDX(1))  
10      NOUTP = NOUTP  
20      IF (NLINE) 30,30,50  
30      WRITE OUTPUT TAPE 6,40  
40      FORMAT(//81H      TIME      VX      VY      VZ      O  
1MEGAX      OMEGAY      OMEGAZ/  
2      82H      SEC      IN/SEC      IN/SEC      IN/SEC      R  
3AD/SEC      RAD/SEC      RAD/SEC//)  
50      WRITE OUTPUT TAPE 6,60,T,VX,VY,VZ,OMX,OMY,OMZ  
60      FORMAT(F11.3,1P6E12.4)  
70      NLO = NLINE+1  
80      DO 130 NPO=1,NOUTP  
90      OUTP(NPO,NLO,1) = T  
100     NEOS = NEOL(NPO)  
110     DO 130 NEO=2,NEOS  
120     NE = 5*NPO+NEO-6  
130     OUTP(NPO,NLO,NEO) = PP(NE)  
140     IF(NLINE-54) 160,150,150  
150     CALL LASOUT  
160     RETURN  
      END  
0033
```

Contrails

* LIST
* SYMBOL TABLE
CLASOUT

```
          SUBROUTINE LASOUT  
          COMMON VAR  
          DIMENSION VAR(24000),P(23400),NTEGER(225),  
1  OUTP(6,57,6),NEOL(6),Y(75),DYDX(75),PP(30)  
          EQUIVALENCE (VAR(601),P(1)),(VAR(376),NTEGER(1)),  
1  (P(17989),OUTP(1)),(NTEGER(33),NEOL(1)),(NTEGER(39),NOUTP),  
2  (NTEGER(40),NLO),(NTEGER(42),NLINE),(Y(1),T),(Y(2),VX),  
3  (Y(3),VY),(Y(4),VZ),(DYDX(2),VXD),(DYDX(3),VYD),(DYDX(4),VZD),  
4  (P(24),OMX),(P(25),OMY),(P(26),OMZ)  
10          NLO = NLO  
20          NOUTP = NOUTP  
30          DO 170 NPO = 1,NOUTP  
40          CALL PAGEHD  
50          NE = 5*(NPO-1)  
60          NE1 = NE+1  
70          NE2 = NE+2  
80          NE3 = NE+3  
90          NE4 = NE+4  
100         NE5 = NE+5  
110        WRITE OUTPUT TAPE 6,120,NE1,NE2,NE3,NE4,NE5  
120        FORMAT(///18H      TIME      P-12,11H      P-12,  
1  11H      P-12,11H      P-12,11H      P-12//)  
130        DO 170 J=1,NLO  
140        NEOS = NEOL(NPO)  
150        WRITE OUTPUT TAPE 6,160,(OUTP(NPO, J,NEO),  
1  NEO = 1,NEOS)  
160        FORMAT(F11.3,1P5E13.5)  
170        CONTINUE  
180        RETURN  
          END  
0033
```

Contrails

```
* LIST
* SYMBOL TABLE
COUTPUT
SUBROUTINE OUTPUT
COMMON VAR
DIMENSION VAR(24000),P(23400),Y(75),NTEGER(225)
EQUIVALENCE (VAR(1),Y(1)),(VAR(376),NTEGER(1)),
1 (VAR(601),P(1)),(NTEGER(13),NTSKIP),(NTEGER(41),LPRINT),
2 (NTEGER(42),NLINE),(NTEGER(43),NSKIP)
EQUIVALENCE (NTEGER(18),NOTD),(NTEGER(19),NOTD1),
1 (NTEGER(20),NOTD2)
10 IF (Y(1) - P(2)) 20, 50, 50
C DETERMINE WHETHER OR NOT TO PRINT ON THIS INTEGRATION STEP
20 IF (NSKIP - NTSKIP) 30, 50, 50
30 NSKIP = NSKIP + 1
40 GO TO 150
C DETERMINE IF A NEW PAGE IS REQUIRED FOR PRINTING OF RESULTS
50 IF (NLINE = 55) 90,70,70
C HEAD A NEW PAGE
70 CALL PAGEMD
80 NLINE = 0
90 CALL OUTAID
100 NLINE = NLINE + LPRINT + 1
110 NSKIP = 0
C ON THE LAST STEP OF THE INTEGRATION GO TO NEXT RUN
120 IF (Y(1) - P(2)) 150, 150, 130
130 CALL LASOUT
135 IF (NOTD) 140,140,136
136 CALL PDUMP (VAR,VAR(150),1,VAR(226),VAR(300),1,
1 NTEGER,NTEGER(46),2,P(7531),P(21840),1)
140 CALL RK
150 RETURN
END
0033
```

Contrails

```
* LIST  
* SYMBOL TABLE  
CPAGEHD
```

```
          SUBROUTINE PAGEHD  
          COMMON VAR  
          DIMENSION VAR(24000),NTEGER(225)  
          EQUIVALENCE (VAR(376),NTEGER(1)),(NTEGER(1),IDENT),  
1  (NTEGER(42),NLINE),(NTEGER(44),NPAGE)  
10         NPAGE = NPAGE + 1  
20         WRITE OUTPUT TAPE 6,30, IDENT, NPAGE  
30         FORMAT (13H1      RUN NO   I5,53H  
1           PAGE NO   I5)  
50         RETURN  
          END  
0014
```

Contrails

* LIST
* SYMBOL TABLE
CFORSEL

```
1          SUBROUTINE FORSEL  
2          COMMON VAR  
10         DIMENSION VAR(24000),NTEGER(225)  
15         EQUIVALENCE (VAR(376),NTEGER(1))  
20         NSUBR = NTEGER(10)  
25         GO TO (10,20,30,40,50,60,70,80,90),NSUBR  
30         CALL FORCE1  
35         GO TO 95  
40         CALL FORCE2  
45         GO TO 95  
50         CALL FORCE3  
55         GO TO 95  
60         CALL FORCE4  
65         GO TO 95  
70         CALL FORCE5  
75         GO TO 95  
80         CALL FORCE6  
85         GO TO 95  
90         CALL FORCE7  
95         GO TO 95  
          CALL FORCE8  
          CALL FORCE9  
          RETURN  
          END  
0028
```

Contrails

* LIST
* SYMBOL TABLE
CFORCE1

```
      SUBROUTINE FORCE1  
      COMMON VAR  
      DIMENSION VAR(24000),P(23400),PF(30),NTEGER(225)  
      EQUIVALENCE (VAR(1),T),(VAR(601),P(1)),(P(4),C5),  
1 (VAR(376),NTEGER(1)),(P(121),PF(1)),(NTEGER(8),NPS),(P(3),C3),  
2 (P(5),TS)  
10      DO 20 I=1,NPS  
20      PF(I) = 0.0  
30      IF(T-TS) 40,40,60  
40      FT = 1.0  
50      GO TO 70  
60      FT = 0.0  
70      PF(3) = C3*FT  
80      PF(5) = C5*FT  
90      RETURN  
      END  
0019
```

Contrails

```
*      LIST
CFORCE2          SUBROUTINE FORCE2
                  RETURN
                  END

*      LIST
CFORCE3          SUBROUTINE FORCE3
                  RETURN
                  END

*      LIST
CFORCE4          SUBROUTINE FORCE4
                  RETURN
                  END

*      LIST
CFORCE5          SUBROUTINE FORCE5
                  RETURN
                  END

*      LIST
CFORCE6          SUBROUTINE FORCE6
                  RETURN
                  END

*      LIST
CFORCE7          SUBROUTINE FORCE7
                  RETURN
                  END

*      LIST
CFORCE8          SUBROUTINE FORCE8
                  RETURN
                  END

*      LIST
CFORCE9          SUBROUTINE FORCE9
                  RETURN
                  END

0040
```

4.0 SAMPLE ANALYSIS USING DIGITAL ROUTINE

4.1 Geometry and Basic Data for Multi-Cylinder Model to be Used in Checking Digital Routine

The geometry of the idealized missile is shown in Figure 110.

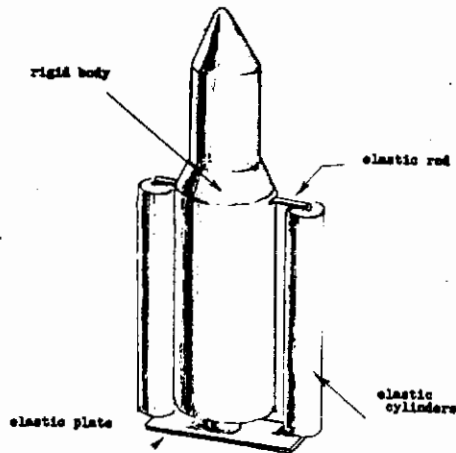

FIGURE 110 EXAMPLE VEHICLE

For the purposes of dynamic analysis the model is assumed to consist of a rigid body supporting two homogenous circular cylinders that are cantilevered from a uniform, homogenous, flat plate. The cylinders are secured at top by a uniform thin rod which is cantilevered from the rigid body and pinned to the top of the cylinders.

The relative dimensions of the system are shown in Figure 111.

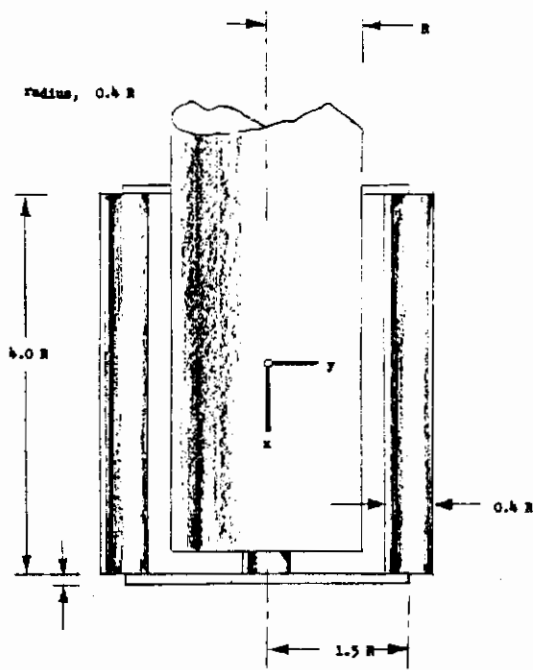

FIGURE 111 MODEL DIMENSIONS

Contrails

The cylinders will be allowed parabolic deformations in two directions. The bottom plate can deform so that slices parallel to the Z-axis remain rigid. The rods can deform axially and bend in two directions.

The result is a system with 14 degrees-of-freedom. The 14 generalized coordinates are shown in Figure 112.

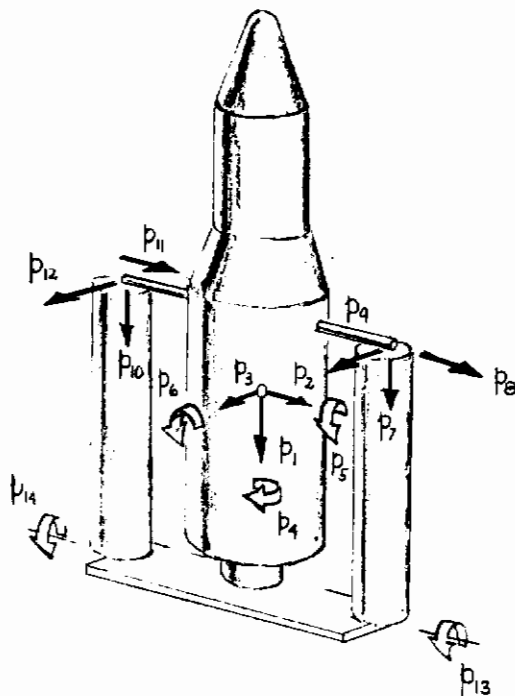

FIGURE 112 GENERALIZED COORDINATES

In Figure 112 p_1 , p_2 , p_3 , p_4 , p_5 , and p_6 are displacements and rotations of the rigid body at the origin of coordinates, $x = 0$, $y = 0$, $z = 0$. The generalized coordinates p_7 , p_8 , p_9 , and p_{13} are displacements of the right cylinder relative to the rigid body in the center. Likewise, p_{10} , p_{11} , p_{12} and p_{14} are relative displacements for the left cylinder.

Figures 113 and 114 describe the deflection assumptions in detail.

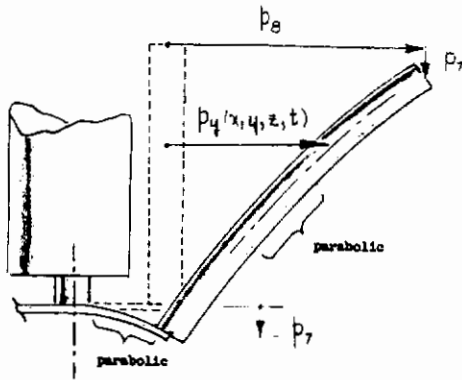

FIGURE 113 DEFLECTIONS IN THE SYMMETRIC PLANE

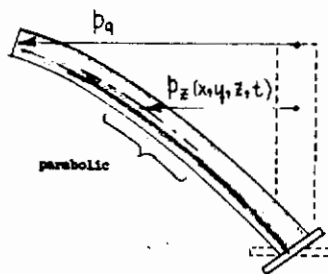

FIGURE 114 DEFLECTIONS IN THE ANTI-SYMMETRIC PLANE

These assumptions are described analytically in the following relations which relate continuous displacements to the finite number of generalized coordinates

(I-33)

$$p_x(x, y, z, t) = \begin{cases}
 p_1(t) + z p_5(t) - y p_6(t) & \text{for } (x, y, z) \text{ on rigid body} \\
 p_1(t) + z p_5(t) - y p_6(t) + p_{10}(t) y^2 \frac{1}{4a^2} + p_{14}(t) z y^2 \frac{1}{4a^2} & \text{for } (x, y, z) \text{ on plate where } y < 0 \\
 p_1(t) + z p_5(t) - y p_6(t) + p_7(t) y^2 \frac{1}{4a^2} + p_3(t) z y^2 \frac{1}{4a^2} & \text{for } (x, y, z) \text{ on plate where } y > 0 \\
 p_1(t) + z p_5(t) - y p_6(t) + p_7(t) & \text{for } (x, y, z) \text{ on right cylinder} \\
 p_1(t) + z p_5(t) - y p_6(t) + p_{10}(t) & \text{for } (x, y, z) \text{ on left cylinder}
 \end{cases}$$

Contrails

(I-34)

$$p_4(x, y, z, t) = \begin{cases} p_2(t) + x p_6(t) - z p_4(t) & \text{for } (x, y, z) \text{ on the rigid body} \\ p_2(t) + x p_6(t) - z p_4(t) & \text{for } (x, y, z) \text{ on plate where } y < 0 \\ p_2(t) + x p_6(t) - z p_4(t) & \text{for } (x, y, z) \text{ on plate where } y > 0 \\ p_2(t) + x p_6(t) - z p_4(t) + p_7(t) \frac{2(x_B - x)}{y_B} \left(1 - \frac{x_B - x}{x_B - x_C}\right) + p_8(t) \frac{(x_B - x)^2}{(x_B - x_C)^2} & \text{for } (x, y, z) \text{ on right cylinder} \\ p_2(t) + x p_6(t) - z p_4(t) + p_9(t) \frac{2(x_E - x)}{y_E} \left(1 - \frac{x_E - x}{x_E - x_D}\right) + p_{11}(t) \frac{(x_E - x)^2}{(x_E - x_D)^2} & \text{for } (x, y, z) \text{ on left cylinder} \end{cases}$$

(I-35)

$$p_4(x, y, z, t) = \begin{cases} p_3(t) + y p_4(t) - x p_5(t) & \text{for } (x, y, z) \text{ on the rigid body} \\ p_3(t) + y p_4(t) - x p_5(t) & \text{for } (x, y, z) \text{ on plate where } y < 0 \\ p_3(t) + y p_4(t) - x p_5(t) & \text{for } (x, y, z) \text{ on plate where } y > 0 \\ p_3(t) + y p_4(t) - x p_5(t) + p_{13}(t) \frac{2(x_B - x)}{y_B} \left(1 - \frac{x_B - x}{x_B - x_C}\right) + p_{14} \frac{(x_B - x)^2}{(x_B - x_C)^2} & \text{for } (x, y, z) \text{ on right cylinder} \\ p_3(t) + y p_4(t) - x p_5(t) + p_{14}(t) \frac{2(x_E - x)}{y_E} \left(1 - \frac{x_E - x}{x_E - x_D}\right) + p_{12} \frac{(x_E - x)^2}{(x_E - x_D)^2} & \text{for } (x, y, z) \text{ on left cylinder} \end{cases}$$

Contrails

These relations define $\{h_x(x,y,z)\}$, $\{h_y(x,y,z)\}$, and $\{h_z(x,y,z)\}$ which were introduced in Section 4.0.

$$p_x(x,y,z,t) = \{h_x(x,y,z)\}' \{p(t)\} \quad (\text{I-36})$$

$$p_y(x,y,z,t) = \{h_y(x,y,z)\}' \{p(t)\} \quad (\text{I-37})$$

$$p_z(x,y,z,t) = \{h_z(x,y,z)\}' \{p(t)\} \quad (\text{I-38})$$

The inertia matrices can then be calculated

$$[A_{xx}] = \int \{h_x\} \{h_x\}' \rho dV \quad (\text{I-39})$$

$$[A_{yy}] = \int \{h_y\} \{h_y\}' \rho dV \quad (\text{I-40})$$

$$[A_{zz}] = \int \{h_z\} \{h_z\}' \rho dV \quad (\text{I-41})$$

$$[A_{zy}] = \int \{h_z\} \{h_y\}' \rho dV \quad (\text{I-42})$$

$$[A_{zx}] = \int \{h_z\} \{h_x\}' \rho dV \quad (\text{I-42})$$

$$[A_{yx}] = \int \{h_y\} \{h_x\}' \rho dV \quad (\text{I-42})$$

$$[A_{xy}] = \int \{h_x\} \{h_y\}' \rho dV \quad (\text{I-42})$$

$$[A_{yz}] = \int \{h_y\} \{h_z\}' \rho dV \quad (\text{I-43})$$

$$[A_{zy}] = \int \{h_z\} \{h_y\}' \rho dV \quad (\text{I-43})$$

$$[A_{xz}] = \int \{h_x\} \{h_z\}' \rho dV \quad (\text{I-43})$$

$$[A_{zx}] = \int \{h_z\} \{h_x\}' \rho dV \quad (\text{I-43})$$

$$[A_{xy}] = \int \{h_x\} \{h_y\}' \rho dV \quad (\text{I-44})$$

$$[A_{yx}] = \int \{h_y\} \{h_x\}' \rho dV \quad (\text{I-44})$$

The integration is broken down over the rigid body, the two cylinders, and the two parts of the plate as follows:

$$\int (\quad) \rho dV = \iiint_{(\text{RIGID BODY})} (\quad) \rho dx dy dz \quad (\text{I-45})$$

$$+ \int_{x_c}^{x_b} (\quad)_{\substack{y=y_B \\ z=0}} \rho A dx$$

$$+ \int_{x_D}^{x_E} (\quad)_{\substack{y=y_E \\ z=0}} \rho A dx$$

$$+ \int_{y_E}^0 \int_{-b}^b (\quad)_{x=x_A} \rho \tau dz dy$$

$$+ \int_0^{y_B} \int_{-b}^b (\quad)_{x=x_A} \rho \tau dz dy$$

Contrails

In these expressions A is the cross-sectional area of the cylinders, τ is the thickness of the plate and $2b$ is the width of the plate.

These matrices have been calculated and are listed in Table 13. The calculations were based on the dimensions in Figure 111 with

$$R = 340 \text{ ins.} \quad (\text{I-46})$$

and

$$\rho = 1.2 \times 10^{-3} \frac{\text{slinches}}{\text{m}^3} = 3.1088 \times 10^{-6} \frac{\text{slinches}}{\text{m}^3} \quad (\text{I-47})$$

The results are expressed in the "slinch-inch-sec" system of units. The "slinch", which is the mass unit, is one $\text{lb}_m\text{-sec}^2/\text{in}$. This is the only consistent set of units using inches for length and pounds for force. The digital routine, Pandora, is coded for accepting input data in any consistent set of units.

The strain energy of the system is

(I-48)

$$\begin{aligned} U = & \frac{1}{2} \int_{x_c}^{x_b} EI \left(\left(\frac{\partial^2 y}{\partial x^2} \right)^2 + \left(\frac{\partial^2 z}{\partial x^2} \right)^2 \right) dx + \frac{1}{2} \int_{x_0}^x EI \left(\left(\frac{\partial^2 y}{\partial x^2} \right)^2 + \left(\frac{\partial^2 z}{\partial x^2} \right)^2 \right) dx \\ & + \frac{1}{2} \int_{y_0}^{y_b} \int_{-b}^b \frac{E\tau^3}{12(1-\nu^2)} \left(\left(\frac{\partial^2 p_x}{\partial y^2} \right)^2 + \left(\frac{\partial^2 p_x}{\partial z^2} \right)^2 + 2\nu \left(\frac{\partial^2 p_x}{\partial y^2} \right) \left(\frac{\partial^2 p_x}{\partial z^2} \right) + 2(1-\nu) \left(\frac{\partial^2 p_x}{\partial y \partial z} \right)^2 \right) dy dz \\ & + \frac{1}{2} \left(\frac{l^3 + \frac{3}{4} \frac{E}{G} \pi^2 l}{\frac{3}{4} E \pi \pi^4} \right) p_r^2 + \frac{1}{2} \left(\frac{E \pi \pi^2}{l} \right) p_\theta^2 \\ & \quad + \left(\frac{l^3 + \frac{3}{4} \frac{E}{G} \pi^2 l}{\frac{3}{4} E \pi \pi^2} \right) p_1^2 \\ & + \frac{1}{2} \left(\frac{l^3 + \frac{3}{4} \frac{E}{G} \pi^2 l}{\frac{3}{4} E \pi \pi^4} \right) p_0^2 + \frac{1}{2} \left(\frac{E \pi \pi^2}{l} \right) p_{11}^2 + \frac{1}{2} \left(\frac{l^3 + \frac{3}{4} \frac{E}{G} \pi^2 l}{\frac{3}{4} E \pi \pi^4} \right) p_{12}^2 \end{aligned}$$

where r is the radius and l is the length of the rod.

When equations I-36, I-37, and I-38 are introduced we obtain

$$U = \frac{1}{2} \{p\}' [K] \{p\} \quad (\text{I-49})$$

Contrails

The stiffness matrix is listed in Table 14 for the following

$$\nu = 0.25 \quad (\text{I-50})$$

and

$$E = 9.637 \times 10^2 \text{ lb}_F / \text{in}^2 \quad (\text{I-51})$$

The fictitious values of ρ , and E are introduced to make the homogenous model representative of a missile about 170 feet long with a total mass of 950,600 lb_M and a fundamental free-free frequency of about 1.0 cps.

The damping matrix was taken as

$$[B] = \rho [K] \quad (\text{I-53})$$

The vibration modes are listed in Table 17.

Contrails

TABLE 14
INERTIA MATRICES OF MULTI-CYLINDER MODEL

INERTIA MATRICES FOR
MULTI-CYLINDER MODEL

$$[A_{xx}]$$

ROW	COLUMN				
	1	2	3	4	5
1	2.46269E 03	0.	0.	0.	0.
5	0.	0.	0.	0.	6.69156E 07
7	6.75281E 01	0.	0.	0.	0.
10	6.75281E 01	0.	0.	0.	0.
13	0.	0.	0.	0.	5.88542E 04
14.	0.	0.	0.	0.	5.88542E 04

ROW	COLUMN				
	6	7	8	9	10
1	0.	6.75281E 01	0.	0.	6.75281E 01
6	1.01691E 08	-3.36604E 04	0.	0.	3.36604E 04
7	-3.36604E 04	6.50843E 01	0.	0.	0.
10	3.36604E 04	0.	0.	0.	6.50843E 01

ROW	COLUMN			
	11	12	13	14
5	0.	0.	5.88542E 04	5.88542E 04
13	0.	0.	3.53125E 04	0.
14	0.	0.	0.	3.53125E 04

Contrails

INERTIA MATRICES FOR MULTI-CYLINDER MODEL

[A_{yy}]

ROW	COLUMN				
	1	2	3	4	5
2	0.	2.46269E 03	0.	0.	0.
4	0.	0.	0.	6.69156E 07	0.
6	0.	7.91544E 04	0.	0.	0.
7	0.	5.45944E 01	0.	0.	0.
8	0.	2.04729E 01	0.	0.	0.
10	0.	-5.45944E 01	0.	0.	0.
11	0.	2.04729E 01	0.	0.	0.

ROW	COLUMN				
	6	7	8	9	10
2	7.91544E 04	5.45944E 01	2.04729E 01	0.	-5.45944E 01
6	8.70021E 08	1.85621E 04	0.	0.	-1.85621E 04
7	1.85621E 04	5.82340E 01	1.63783E 01	0.	0.
8	0.	1.63783E 01	1.22837E 01	0.	0.
10	-1.85621E 04	0.	0.	0.	5.82340E 01
11	0.	0.	0.	0.	1.63783E 01

ROW	COLUMN			
	11	12	13	14
2	2.04729E 01	0.	0.	0.
10	1.63783E 01	0.	0.	0.
11	1.22837E 01	0.	0.	0.

Contrails

INERTIA MATRICES FOR MULTI-CYLINDER MODEL

[A_{zz}]

ROW	COLUMN				
	1	2	3	4	5
3	0.	0.	2.46269E 03	0.	-7.91544E 04
4	0.	0.	0.	1.01691E 08	0.
5	0.	0.	-7.91544E 04	0.	8.70021E 08
9	0.	0.	2.04729E 01	1.04412E 04	0.
12	0.	0.	2.04729E 01	-1.04412E 04	0.
13	0.	0.	1.39216E 04	7.10000E 06	-4.73333E 06
14	0.	0.	1.39216E 04	-7.10000E 06	-4.73333E 06

ROW	COLUMN				
	6	7	8	9	10
3	0.	0.	0.	2.04729E 01	0.
4	0.	0.	0.	1.04412E 04	0.
9	0.	0.	0.	1.22837E 01	0.
13	0.	0.	0.	4.17647E 03	0.

ROW	COLUMN			
	11	12	13	14
3	0.	2.04729E 01	1.39216E 04	1.39216E 04
4	0.	-1.04412E 04	7.10000E 06	-7.10000E 06
5	0.	0.	-4.73333E 06	-4.73333E 06
9	0.	0.	4.17647E 03	0.
12	0.	1.22837E 01	0.	4.17647E 03
13	0.	0.	3.78667E 06	0.
14	0.	4.17647E 03	0.	3.78667E 06

Contrails

INERTIA MATRICES FOR MULTI-CYLINDER MODEL

[A_{yx}]

ROW	COLUMN				
	1	2	3	4	5
2	2.46269E 03	0.	0.	0.	0.
4	0.	0.	0.	0.	-6.69156E 07
6	7.91544E 04	0.	0.	0.	0.
7	5.45944E 01	0.	0.	0.	0.
8	2.04729E 01	0.	0.	0.	0.
10	-5.45944E 01	0.	0.	0.	0.
11	2.04729E 01	0.	0.	0.	0.

ROW	COLUMN				
	6	7	8	9	10
2	0.	6.75281E 01	0.	0.	6.75281E 01
6	0.	2.71140E 04	0.	0.	2.71140E 04
7	-2.78431E 04	5.45944E 01	0.	0.	0.
8	-1.04412E 04	2.04729E 01	0.	0.	0.
10	-2.78431E 04	-0.	0.	0.	-5.45944E 01
11	1.04412E 04	-0.	0.	0.	2.04729E 01

ROW	COLUMN			
	11	12	13	14
4	0.	0.	-5.88542E 04	-5.88542E 04

INERTIA MATRICES FOR MULTI-CYLINDER MODEL

$$[A_{zx}]$$

ROW	COLUMN				
	1	2	3	4	5
3	2.46269E 03	0.	0.	0.	0.
5	-7.91544E 04	0.	0.	0.	0.
9	2.04729E 01	0.	0.	0.	0.
12	2.04729E 01	0.	0.	0.	0.
13	1.39216E 04	0.	0.	0.	0.
14	1.39216E 04	0.	0.	0.	0.

ROW	COLUMN				
	6	7	8	9	10
3	0.	6.75281E 01	0.	0.	6.75281E 01
4	-1.01691E 08	3.36604E 04	0.	0.	-3.36604E 04
5	0.	-2.71140E 04	0.	0.	-2.71140E 04
9	-1.04412E 04	2.04729E 01	0.	0.	0.
12	1.04412E 04	0.	0.	0.	2.04729E 01
13	-7.10000E 06	1.39216E 04	0.	0.	0.
14	7.10000E 06	0.	0.	0.	1.39216E 04

Contrails

INERTIA MATRICES FOR MULTI-CYLINDER MODEL

[A_{zy}]

ROW	COLUMN				
	1	2	3	4	5
3	0.	2.46269E 03	0.	0.	0.
5	0.	-7.91544E 04	0.	0.	0.
9	0.	2.04729E 01	0.	0.	0.
12	0.	2.04729E 01	0.	0.	0.
13	0.	1.39216E 04	0.	0.	0.
14	0.	6.18736E 03	0.	0.	0.

ROW	COLUMN				
	6	7	8	9	10
3	7.91544E 04	5.45944E 01	2.04729E 01	0.	5.45944E 01
4	0.	2.78431E 04	1.04412E 04	0.	2.78431E 04
5	-8.70021E 08	-1.85621E 04	0.	0.	1.85621E 04
9	0.	1.63783E 01	1.22837E 01	0.	0.
12	0.	0.	0.	0.	1.63783E 01
13	4.73333E 06	7.42484E 03	4.17647E 03	0.	0.
14	4.73333E 06	0.	0.	0.	7.42484E 03

ROW	COLUMN			
	11	12	13	14
3	2.04729E 01	0.	0.	0.
4	-1.04412E 04	0.	0.	0.
12	1.22837E 01	0.	0.	0.
14	4.17647E 03	0.	0.	0.

TABLE 15
STIFFNESS MATRIX OF MULTI-CYLINDER MODEL

STIFFNESS MATRIX FOR
MULTI-CYLINDER MODEL

[K]
COLUMN

ROW

	6	7	8	9	10
7	0.	7.82137E 02	-1.37249E 02	0.	0.
8	0.	-1.37249E 02	3.31971E 03	0.	0.
9	0.	0.	0.	4.13578E 01	0.
10	0.	0.	0.	0.	7.82137E 02
11	0.	0.	0.	0.	1.37249E 02
13	0.	0.	0.	-3.49985E 04	0.

ROW

COLUMN

	11	12	13	14
9	0.	0.	-3.49985E 04	0.
10	1.37249E 02	0.	0.	0.
11	3.31971E 03	0.	0.	0.
12	0.	4.13578E 01	0.	-3.49985E 04
13	0.	0.	5.24197E 07	0.
14	0.	-3.49985E 04	0.	5.24197E 07

**TABLE 16
DAMPING MATRIX OF MULTI-CYLINDER MODEL**

DAMPING MATRIX FOR
MULTI-CYLINDER MODEL
[B]

ROW	COLUMN				
	6	7	8	9	13
7	0.	0.	4.61461E-03	-8.09769E-04	0.
8	0.	0.	-8.09769E-04	1.95863E-02	0.
9	0.	0.	0.	0.	2.44011E-04
13	0.	0.	0.	0.	-2.06491E-01

ROW	COLUMN			
	11	12	13	14
9	0.	0.	-2.06491E-01	0.
10	8.09769E-04	0.	0.	0.
11	1.95863E-02	0.	0.	0.
12	0.	2.44011E-04	0.	-2.06491E-01
13	0.	0.	3.09276E 02	0.
14	0.	-2.06491E-01	0.	3.09276E 02

TABLE 17
VIBRATION MODES AND FREQUENCIES OF MULTI-CYLINDER MODEL

RIGID BODY MODES OF
MULTI-CYLINDER MODEL

COLL. POINT	1ST MODE 0 CPS	2ND MODE 0 CPS	3RD MODE 0 CPS
1	1.0000000E 00	0.	0.
2	0.	1.0000000E 00	0.
3	0.	0.	1.0000000E 00

COLL. POINT	4TH MODE 0 CPS	5TH MODE 0 CPS	6TH MODE 0 CPS
2	0.	0.	-3.2141383E 01
3	0.	3.2141383F 01	0.
4	1.0000000E 00	0.	0.
5	0.	1.0000000E 00	0.
6	0.	0.	1.0000000E 00

ELASTIC VIBRATION MODES OF
MULTI-CYLINDER MODEL

COLL. POINT	7TH MODE 0.1525 CPS	8TH MODE 0.1616 CPS	9TH MODE 0.4017 CPS	10TH MODE 0.4064 CPS
1	0.	0.	-1.1133801E-04	-1.4099310E-04
2	0.	0.	-1.1833926E-04	9.3313473E-05
3	-2.0188738E-04	-6.9968322E-12	0.	0.
4	3.5300905E-14	-1.6040825E-06	0.	0.
5	4.5499184E-08	1.5349514E-15	0.	0.
6	0.	0.	8.8626299E-08	-7.1413935E-08
7	0.	0.	4.5719504E-03	5.1748866E-04
8	0.	0.	3.3601228E-04	4.2828283E-05
9	7.9674938E-03	8.4550517E-03	0.	0.
10	0.	0.	-5.1154501E-04	4.6244134E-03
11	0.	0.	4.3165546E-07	-3.9645560E-05
12	7.9674943E-03	-8.4550512E-03	0.	0.
13	6.2691606E-06	6.6124635E-06	0.	0.
14	6.2691609E-06	-6.6124632E-06	0.	0.

ELASTIC VIBRATION MODES OF
MULTI-CYLINDER MODEL

COLL. POINT	11TH MODE 0.9697 CPS	12TH MODE 0.9711 CPS	13TH MODE 2.899 CPS	14TH MODE 2.951 CPS
1	0.	0.	5.6372719E-06	8.8310978E-05
2	0.	0.	6.3957797E-05	-1.9864260E-04
3	7.5097082E-05	2.5339505E-05	0.	0.
4	-2.3025346E-07	6.8238795E-07	0.	0.
5	-2.0908947E-07	-7.0551745E-08	0.	0.
6	0.	0.	-5.4058644E-08	2.0338822E-08
7	0.	0.	-1.6747193E-03	-1.4765217E-03
8	0.	0.	1.1784473E-02	1.0961930E-02
9	6.5869496E-03	1.2698821E-02	0.	0.
10	0.	0.	1.4691340E-03	-1.7441080E-03
11	0.	0.	-1.0885370E-02	1.2140689E-02
12	1.2934143E-02	-6.1119409E-03	0.	0.
13	-1.4189395E-05	-2.9219000E-05	0.	0.
14	-2.8991421E-05	1.4648770E-05	0.	0.

4.2 Sample Problems

The digital program was demonstrated for three different problems:

- (1) Response to simplified gust. Generalized forces were taken as

$$P_3(t) = -\frac{1}{2} \rho v_w^2 c_{L\alpha} \frac{w}{v_w} (H(t) - H(t-t^*)) \quad (\text{I-54})$$

$$P_5(t) = -\frac{1}{2} \rho v_w^2 c_{M\alpha} \frac{w}{v_w} (H(t) - H(t-t^*)) \quad (\text{I-55})$$

where

$$H(t) = \begin{cases} 1 & \text{for } t \geq 0 \\ 0 & \text{for } t < 0 \end{cases} \quad (\text{I-56})$$

$$v_w = 2.442 \times 10^4 \text{ in/sec} \quad (\text{I-57})$$

$$t^* = 0.5325 \text{ secs. (five missile lengths)}$$

$$\frac{w}{v_w} = 9.828 \times 10^{-3} \text{ (20 ft/sec. gust)}$$

$$c_{L\alpha} = 2.011 \times 10^5 \text{ in}^2$$

$$c_{M\alpha} = 2.373 \times 10^8 \text{ in}^3$$

- (2) Response to impulsive spin-up. External forces were zero; all initial conditions zero except $\Omega_x(0)$.

$$\Omega_x(0) = 10 \text{ rad./sec.} \quad (\text{I-58})$$

All other forces were zero. All initial conditions were zero.

- (3) Response to initial displacements in first mode of vibration. All external forces were zero; all initial conditions were zero except $\{p(0)\}$.

$$\{p(0)\} = \{\varphi\}, = \text{the first mode of vibration} \quad (\text{I-59})$$

The results of these problems are given on the following pages.

TABLE 18
DATA READ INTO THE COMPUTER FOR SAMPLE RUNS

1 5 0 0 0 0 0 14 1 1

PANDORA - LVV420 15 AUG 1963

RESPONSE OF TITAN III MODEL TO GUST

1 .1
2 20.0
3 1235.25675
4 1457615.25
5 .5325

2 5 0 1 0 0 0 14 0 1

PANDORA - LVV420 15 AUG 1963

RESPONSE OF TITAN III MODEL TO IMPULSIVE SPIN-UP

1 .05
2 10.0
3 0.0
4 0.0
5 0.0
5 8.43 +7

3 9 0 1 0 0 0 14 0 1

PANDORA - LVV420 15 AUG 1963

RESPONSE OF TITAN III MODEL TO INITIAL DISPLACEMENTS IN ITS 1ST MODE

1 .1
2 5.0
63 -.20189733-03
64 .35300905-13
65 .45499184-07
69 .79674929-02
72 .79674942-02
73 .62691604-05
74 .62691610-05
5 0.0

0030

TABLE 19
LISTINGS OF COMPUTER RUNS FOR TRANSIENT GUST RESPONSE

RUN NO 1
PANDORA - LVV420 15 AUG 1963
RESPONSE OF TITAN III MODEL TO GUST

PAGE NO 1

TIME SEC	VX IN/SEC	VY IN/SEC	VZ IN/SEC	OMEGAX RAD/SEC	OMEGAY RAD/SEC	OMEGAZ RAD/SEC
0.	0.	0.	0.	-0.	0.	0.
0.100	-2.6792E-07	-8.6144E-20	5.0159E-02	-4.5379E-17	1.6025E-04	-5.9227E-20
0.200	-2.1434E-06	-6.4326E-18	1.0032E-01	-4.1189E-15	3.2049E-04	3.3259E-18
0.300	-7.2339E-06	-1.5451E-16	1.5048E-01	-3.9934E-14	4.8074E-04	1.3559E-18
0.400	-1.7147E-05	-1.4760E-15	2.0063E-01	-1.7194E-13	6.4098E-04	5.1520E-17
0.500	-3.3490E-05	-7.7982E-15	2.5079E-01	-5.2731E-13	8.0123E-04	1.4679E-16
0.600	-5.4963E-05	-2.7318E-14	2.5915E-01	-1.3533E-12	8.2793E-04	2.5777E-16
0.700	-7.6420E-05	-7.1129E-14	2.5915E-01	-2.1089E-12	8.2793E-04	4.7445E-16
0.800	-9.7876E-05	-1.3664E-13	2.5915E-01	-2.9904E-12	8.2793E-04	6.7286E-16
0.900	-1.1933E-04	-2.2397E-13	2.5915E-01	-3.9134E-12	8.2793E-04	9.1577E-16
1.000	-1.4079E-04	-3.3335E-13	2.5915E-01	-4.4121E-12	8.2793E-04	9.5955E-16
1.100	-1.6224E-04	-4.5181E-13	2.5915E-01	-4.3517E-12	8.2793E-04	1.4810E-15
1.200	-1.8370E-04	-5.6237E-13	2.5915E-01	-3.8636E-12	8.2793E-04	1.5424E-15
1.300	-2.0516E-04	-6.5421E-13	2.5915E-01	-2.8500E-12	8.2793E-04	1.7491E-15
1.400	-2.2661E-04	-7.1529E-13	2.5915E-01	-1.3326E-12	8.2793E-04	1.8073E-15
1.500	-2.4807E-04	-7.3346E-13	2.5915E-01	3.4964E-13	8.2793E-04	1.7811E-15
1.600	-2.6953E-04	-7.0621E-13	2.5915E-01	2.0189E-12	8.2793E-04	1.9964E-15
1.700	-2.9098E-04	-6.3624E-13	2.5915E-01	3.6618E-12	8.2793E-04	1.7863E-15
1.800	-3.1244E-04	-5.2512E-13	2.5915E-01	5.1461E-12	8.2793E-04	1.5219E-15
1.900	-3.3389E-04	-3.7707E-13	2.5915E-01	6.3895E-12	8.2793E-04	1.3888E-15
2.000	-3.5535E-04	-1.9878E-13	2.5915E-01	7.4463E-12	8.2793E-04	3.1005E-16
2.100	-3.7681E-04	4.6799E-15	2.5915E-01	8.3024E-12	8.2793E-04	2.5036E-16
2.200	-3.9826E-04	2.2801E-13	2.5915E-01	8.8627E-12	8.2793E-04	-1.7623E-16
2.300	-4.1972E-04	4.6282E-13	2.5915E-01	9.0684E-12	8.2793E-04	-9.5399E-16
2.400	-4.4117E-04	6.9891E-13	2.5915E-01	8.8685E-12	8.2793E-04	-1.5077E-15
2.500	-4.6263E-04	9.2514E-13	2.5915E-01	8.2015E-12	8.2793E-04	-2.0804E-15
2.600	-4.8409E-04	1.1292E-12	2.5915E-01	7.0821E-12	8.2793E-04	-2.9436E-15
2.700	-5.0554E-04	1.2999E-12	2.5915E-01	5.6188E-12	8.2793E-04	-3.2349E-15
2.800	-5.2700E-04	1.4294E-12	2.5915E-01	3.9626E-12	8.2793E-04	-3.6925E-15
2.900	-5.4845E-04	1.5147E-12	2.5915E-01	2.2900E-12	8.2793E-04	-4.1435E-15
3.000	-5.6991E-04	1.5571E-12	2.5915E-01	7.7443E-13	8.2793E-04	-4.3189E-15
3.100	-5.9137E-04	1.5622E-12	2.5915E-01	-4.6882E-13	8.2793E-04	-4.6375E-15
3.200	-6.1282E-04	1.5381E-12	2.5915E-01	-1.4031E-12	8.2793E-04	-4.6673E-15
3.300	-6.3428E-04	1.4928E-12	2.5915E-01	-2.0582E-12	8.2793E-04	-4.6472E-15
3.400	-6.5574E-04	1.4332E-12	2.5915E-01	-2.5060E-12	8.2793E-04	-4.5634E-15
3.500	-6.7719E-04	1.3638E-12	2.5915E-01	-2.8271E-12	8.2793E-04	-4.3871E-15
3.600	-6.9865E-04	1.2873E-12	2.5915E-01	-3.0313E-12	8.2793E-04	-4.2641E-15
3.700	-7.2010E-04	1.2050E-12	2.5915E-01	-3.3009E-12	8.2793E-04	-3.9654E-15
3.800	-7.4156E-04	1.1176E-12	2.5915E-01	-3.5019E-12	8.2793E-04	-3.6774E-15
3.900	-7.6302E-04	1.0256E-12	2.5915E-01	-3.7036E-12	8.2793E-04	-3.4042E-15
4.000	-7.8447E-04	9.2853E-13	2.5915E-01	-3.9401E-12	8.2793E-04	-2.9846E-15
4.100	-8.0593E-04	8.2510E-13	2.5915E-01	-4.2528E-12	8.2793E-04	-2.9163E-15
4.200	-8.2738E-04	7.1289E-13	2.5915E-01	-4.6616E-12	8.2793E-04	-2.3613E-15
4.300	-8.4884E-04	5.8931E-13	2.5915E-01	-5.1356E-12	8.2793E-04	-2.1011E-15
4.400	-8.7030E-04	4.5316E-13	2.5915E-01	-5.5774E-12	8.2793E-04	-1.7888E-15
4.500	-8.9175E-04	3.0645E-13	2.5915E-01	-5.8364E-12	8.2793E-04	-1.1316E-15
4.600	-9.1321E-04	1.5539E-13	2.5915E-01	-5.7526E-12	8.2793E-04	-8.3634E-16
4.700	-9.3466E-04	1.0169E-14	2.5915E-01	-5.2150E-12	8.2793E-04	-5.3974E-16
4.800	-9.5612E-04	-1.1688E-13	2.5915E-01	-4.2070E-12	8.2793E-04	-5.9193E-16
4.900	-9.7758E-04	-2.1404E-13	2.5915E-01	-2.8196E-12	8.2793E-04	-8.7195E-17
5.000	-9.9903E-04	-2.7292E-13	2.5915E-01	-1.2265E-12	8.2793E-04	1.6635E-16
5.100	-1.0205E-03	-2.9015E-13	2.5915E-01	3.7029E-13	8.2793E-04	2.0691E-16
5.200	-1.0419E-03	-2.6748E-13	2.5915E-01	1.7999E-12	8.2793E-04	1.5047E-16
5.300	-1.0634E-03	-2.1048E-13	2.5915E-01	2.9629E-12	8.2793E-04	-2.4986E-17
5.400	-1.0849E-03	-1.2645E-13	2.5915E-01	3.8390E-12	8.2793E-04	-2.4157E-16

Contrails

RUN NO 1

PAGE NO 2

TIME	P- 1	P- 2	P- 3	P- 4	P- 5
0.	0.	0.	0.	0.	0.
0.100	-4.60395E-10	1.97012E-10	3.81060E-05	6.64040E-15	7.62863E-08
0.200	-6.99837E-09	2.09842E-09	1.63815E-04	1.59079E-14	2.71755E-07
0.300	-3.41237E-08	6.41196E-09	4.06582E-04	2.55781E-14	4.99394E-07
0.400	-1.06439E-07	1.24856E-08	8.02761E-04	1.42094E-14	6.49690E-07
0.500	-2.60158E-07	2.06855E-08	1.38143E-03	-1.91118E-14	6.30182E-07
0.600	-5.29714E-07	2.64254E-08	2.12766E-03	-5.47876E-14	3.46154E-07
0.700	-9.07931E-07	2.05301E-08	2.96691E-03	-9.64728E-14	-2.54337E-07
0.800	-1.38382E-06	1.97447E-08	3.83542E-03	-1.04702E-13	-1.00975E-06
0.900	-1.92410E-06	2.01894E-08	4.64873E-03	-1.17640E-13	-1.70019E-06
1.000	-2.48149E-06	1.25639E-08	5.33012E-03	-9.49031E-14	-2.12649E-06
1.100	-3.00939E-06	4.11813E-09	5.83616E-03	-3.58398E-14	-2.18119E-06
1.200	-3.45984E-06	-1.08882E-09	6.17039E-03	5.38372E-14	-1.88662E-06
1.300	-3.78798E-06	-8.48621E-09	6.38036E-03	1.45621E-13	-1.38638E-06
1.400	-3.96516E-06	-1.71846E-08	6.53898E-03	1.99957E-13	-8.93444E-07
1.500	-3.98045E-06	-2.32053E-08	6.71701E-03	2.18807E-13	-6.13380E-07
1.600	-3.83576E-06	-2.87952E-08	6.95649E-03	2.08941E-13	-6.70369E-07
1.700	-3.54522E-06	-3.58136E-08	7.25472E-03	1.61896E-13	-1.06250E-06
1.800	-3.13183E-06	-4.20562E-08	7.56451E-03	1.28900E-13	-1.66235E-06
1.900	-2.62003E-06	-4.70060E-08	7.81055E-03	9.85836E-14	-2.26270E-06
2.000	-2.03300E-06	-5.14383E-08	7.91615E-03	7.11906E-14	-2.65079E-06
2.100	-1.39396E-06	-5.36916E-08	7.83063E-03	5.56974E-14	-2.68465E-06
2.200	-7.26971E-07	-5.19135E-08	7.54761E-03	6.97457E-14	-2.34401E-06
2.300	-5.87578E-08	-4.60701E-08	7.10759E-03	6.37362E-14	-1.71375E-06
2.400	5.78495E-07	-3.60808E-08	6.58396E-03	3.94292E-14	-1.06388E-06
2.500	1.14730E-06	-2.17633E-08	6.05744E-03	-7.04681E-14	-5.40599E-07
2.600	1.60858E-06	-4.32002E-09	5.58808E-03	-1.97743E-13	-3.26250E-07
2.700	1.92668E-06	1.44304E-08	5.19494E-03	-3.14272E-13	-3.63865E-07
2.800	2.07531E-06	3.31237E-08	4.85063E-03	-3.99308E-13	-8.65896E-07
2.900	2.04316E-06	5.04039E-08	4.49274E-03	-4.45763E-13	-1.34606E-06
3.000	1.83687E-06	6.49356E-08	4.04792E-03	-4.15839E-13	-1.68659E-06
3.100	1.47997E-06	7.60545E-08	3.6007E-03	-3.94672E-13	-1.71684E-06
3.200	1.00894E-06	8.35478E-08	2.71244E-03	-3.88662E-13	-1.37484E-06
3.300	4.67062E-07	8.71484E-08	1.83568E-03	-4.37276E-13	-7.29979E-07
3.400	-1.02336E-07	8.66081E-08	8.98990E-04	-5.73701E-13	4.15279E-08
3.500	-6.61165E-07	8.17168E-08	-1.24435E-05	-7.60039E-13	7.19385E-07
3.600	-1.17910E-06	7.21154E-08	-8.25755E-04	-9.45728E-13	1.11777E-06
3.700	-1.63333E-06	5.74790E-08	-1.50417E-03	-1.13743E-12	1.15141E-06
3.800	-2.00639E-06	3.78942E-08	-2.05786E-03	-1.29502E-12	8.65615E-07
3.900	-2.28321E-06	1.40047E-08	-2.53788E-03	-1.43886E-12	4.19371E-07
4.000	-2.44939E-06	-1.29275E-08	-3.01562E-03	-1.56280E-12	2.77349E-08
4.100	-2.49152E-06	-4.09847E-08	-3.55487E-03	-1.63481E-12	-1.15853E-07
4.200	-2.39987E-06	-6.78070E-08	-4.18684E-03	-1.73712E-12	9.05732E-08
4.300	-2.17257E-06	-9.09880E-08	-4.89689E-03	-1.85996E-12	6.20531E-07
4.400	-1.81968E-06	-1.08426E-07	-5.62790E-03	-2.04565E-12	1.32824E-06
4.500	-1.36553E-06	-1.18607E-07	-6.29894E-03	-2.31628E-12	2.00057E-06
4.600	-8.48113E-07	-1.20789E-07	-6.83270E-03	-2.58533E-12	2.43321E-06
4.700	-3.15062E-07	-1.15009E-07	-7.18167E-03	-2.87445E-12	2.50355E-06
4.800	1.82756E-07	-1.01891E-07	-7.34386E-03	-3.12378E-12	2.21435E-06
4.900	5.98614E-07	-8.24305E-08	-7.36237E-03	-3.28784E-12	1.69239E-06
5.000	8.96251E-07	-5.77849E-08	-7.30895E-03	-3.33253E-12	1.14270E-06
5.100	1.05358E-06	-2.91415E-08	-7.25754E-03	-3.27371E-12	7.74811E-07
5.200	1.06309E-06	2.28972E-09	-7.25722E-03	-3.15736E-12	7.27464E-07
5.300	9.29264E-07	3.51693E-08	-7.31437E-03	-3.03839E-12	1.01884E-06
5.400	6.64342E-07	6.78962E-08	-7.39034E-03	-2.97112E-12	1.54010E-06

Contrails

RUN NO 1

PAGE NO 3

TIME	P- 6	P- 7	P- 8	P- 9	P-10
0.	0.	0.	0.	0.	0.
0.100	-1.94319E-14	8.28623E-09	-1.13762E-08	-7.12382E-03	8.50400E-09
0.200	-2.19317E-13	1.26056E-07	-1.18626E-07	-2.69039E-02	1.29169E-07
0.300	-7.45905E-13	6.15036E-07	-3.46552E-07	-5.51806E-02	6.29427E-07
0.400	-1.68913E-12	1.91924E-06	-6.23997E-07	-8.66799E-02	1.96249E-06
0.500	-3.28076E-12	4.69253E-06	-9.27798E-07	-1.16861E-01	4.79523E-06
0.600	-5.29224E-12	9.55808E-06	-9.39705E-07	-1.38640E-01	9.76014E-06
0.700	-6.82048E-12	1.63901E-05	-1.16733E-07	-1.44523E-01	1.67214E-05
0.800	-9.07251E-12	2.49932E-05	4.97229E-07	-1.41739E-01	2.54736E-05
0.900	-1.13408E-11	3.47732E-05	1.07334E-06	-1.40256E-01	3.53972E-05
1.000	-1.24253E-11	4.48821E-05	2.10899E-06	-1.49088E-01	4.56159E-05
1.100	-1.25470E-11	5.44820E-05	3.09774E-06	-1.72988E-01	5.52680E-05
1.200	-1.16622E-11	6.27107E-05	3.71545E-06	-2.10671E-01	6.34669E-05
1.300	-9.06251E-12	6.87584E-05	4.23606E-06	-2.55214E-01	6.93861E-05
1.400	-4.79613E-12	7.21036E-05	4.58794E-06	-2.96481E-01	7.25024E-05
1.500	6.59297E-13	7.25422E-05	4.53032E-06	-3.24709E-01	7.26214E-05
1.600	7.17985E-12	7.00990E-05	4.22500E-06	-3.33960E-01	6.97879E-05
1.700	1.44258E-11	6.50160E-05	3.84424E-06	-3.24215E-01	6.42753E-05
1.800	2.16376E-11	5.76936E-05	3.32322E-06	-3.01344E-01	5.65215E-05
1.900	2.82086E-11	4.85597E-05	2.69440E-06	-2.74974E-01	4.69907E-05
2.000	3.36600E-11	3.80193E-05	2.07153E-06	-2.55020E-01	3.61227E-05
2.100	3.73703E-11	2.64801E-05	1.41646E-06	-2.48126E-01	2.43565E-05
2.200	3.88176E-11	1.43691E-05	6.64701E-07	-2.55289E-01	1.21430E-05
2.300	3.77349E-11	2.16495E-06	-1.43630E-07	-2.71515E-01	-2.21012E-08
2.400	3.39417E-11	-9.55097E-06	-9.71585E-07	-2.87642E-01	-1.15463E-05
2.500	2.73769E-11	-2.00967E-05	-1.79795E-06	-2.93655E-01	-2.17446E-05
2.600	1.82455E-11	-2.87560E-05	-2.53091E-06	-2.82320E-01	-2.99076E-05
2.700	6.96276E-12	-3.48704E-05	-3.05519E-06	-2.51826E-01	-3.53942E-05
2.800	-5.90547E-12	-3.79456E-05	-3.30677E-06	-2.06479E-01	-3.77392E-05
2.900	-1.95897E-11	-3.77545E-05	-3.25350E-06	-1.55220E-01	-3.67580E-05
3.000	-3.31531E-11	-3.43912E-05	-2.89220E-06	-1.08479E-01	-3.25979E-05
3.100	-4.56063E-11	-2.82549E-05	-2.28184E-06	-7.45040E-02	-2.57184E-05
3.200	-5.59645E-11	-1.99795E-05	-1.52265E-06	-5.64873E-02	-1.68157E-05
3.300	-6.33087E-11	-1.03255E-05	-7.10863E-07	-5.15018E-02	-6.70789E-06
3.400	-6.68974E-11	-5.96485E-08	7.26080E-08	-5.16429E-02	3.79175E-06
3.500	-6.62424E-11	1.01386E-05	7.70498E-07	-4.69564E-02	1.39735E-05
3.600	-6.11375E-11	1.97220E-05	1.36587E-06	-2.91009E-02	2.32787E-05
3.700	-5.16877E-11	2.82705E-05	1.87302E-06	5.56919E-03	3.12958E-05
3.800	-3.83177E-11	3.54519E-05	2.31074E-06	5.46068E-02	3.77194E-05
3.900	-2.17368E-11	4.09707E-05	2.68628E-06	1.10263E-01	4.22962E-05
4.000	-2.89161E-12	4.45367E-05	2.98605E-06	1.62178E-01	4.47906E-05
4.100	1.70803E-11	4.58740E-05	3.16962E-06	2.01015E-01	4.49896E-05
4.200	3.69156E-11	4.47709E-05	3.18007E-06	2.21717E-01	4.27505E-05
4.300	5.53011E-11	4.11570E-05	2.96747E-06	2.25244E-01	3.80749E-05
4.400	7.09463E-11	3.51799E-05	2.50990E-06	2.18141E-01	3.11823E-05
4.500	8.26643E-11	2.72491E-05	1.82714E-06	2.10119E-01	2.25507E-05
4.600	8.94602E-11	1.80272E-05	9.85251E-07	2.10502E-01	1.29028E-05
4.700	9.06146E-11	8.35949E-06	8.60371E-08	2.24824E-01	3.13057E-06
4.800	8.57554E-11	-8.39999E-07	-7.56331E-07	2.52795E-01	-5.82496E-06
4.900	7.49125E-11	-8.72091E-06	-1.44131E-06	2.88364E-01	-1.31101E-05
5.000	5.85444E-11	-1.46103E-05	-1.90298E-06	3.21856E-01	-1.80752E-05
5.100	3.75265E-11	-1.80804E-05	-2.12094E-06	3.43420E-01	-2.03428E-05
5.200	1.31035E-11	-1.89574E-05	-2.11687E-06	3.46537E-01	-1.98127E-05
5.300	-1.31906E-11	-1.72770E-05	-1.93828E-06	3.30352E-01	-1.66125E-05
5.400	-3.96393E-11	-1.32116E-05	-1.63678E-06	2.99969E-01	-1.10164E-05

Contrails

RUN NO 1

PAGE NO 4

TIME	P-11	P-12	P-13	P-14	P-15
0.	0.	0.	0.	0.	0.
0.100	-1.16666E-08	-7.12382E-03	7.32265E-06	7.32265E-06	7.32265E-06
0.200	-1.24643E-07	-2.69039E-02	2.58478E-05	2.58478E-05	2.58478E-05
0.300	-3.83488E-07	-5.51806E-02	4.66060E-05	4.66060E-05	4.66060E-05
0.400	-7.56031E-07	-8.66799E-02	5.83141E-05	5.83141E-05	5.83141E-05
0.500	-1.27392E-06	-1.16861E-01	5.14596E-05	5.14596E-05	5.14596E-05
0.600	-1.67971E-06	-1.38640E-01	1.66768E-05	1.66768E-05	1.66768E-05
0.700	-1.44293E-06	-1.44523E-01	-5.06091E-05	-5.06091E-05	-5.06091E-05
0.800	-1.55622E-06	-1.41739E-01	-1.33669E-04	-1.33669E-04	-1.33669E-04
0.900	-1.79396E-06	-1.40256E-01	-2.09749E-04	-2.09749E-04	-2.09749E-04
1.000	-1.61543E-06	-1.49088E-01	-2.58242E-04	-2.58242E-04	-2.58242E-04
1.100	-1.44880E-06	-1.72988E-01	-2.68008E-04	-2.68008E-04	-2.68008E-04
1.200	-1.52265E-06	-2.10671E-01	-2.41317E-04	-2.41317E-04	-2.41317E-04
1.300	-1.50622E-06	-2.55214E-01	-1.92961E-04	-1.92961E-04	-1.92961E-04
1.400	-1.43886E-06	-2.96481E-01	-1.44903E-04	-1.44903E-04	-1.44903E-04
1.500	-1.53021E-06	-3.24709E-01	-1.18343E-04	-1.18343E-04	-1.18343E-04
1.600	-1.61863E-06	-3.33960E-01	-1.26082E-04	-1.26082E-04	-1.26082E-04
1.700	-1.56711E-06	-3.24215E-01	-1.67905E-04	-1.67905E-04	-1.67905E-04
1.800	-1.47348E-06	-3.01344E-01	-2.30644E-04	-2.30644E-04	-2.30644E-04
1.900	-1.33319E-06	-2.74974E-01	-2.92893E-04	-2.92893E-04	-2.92893E-04
2.000	-1.07187E-06	-2.55020E-01	-3.32681E-04	-3.32681E-04	-3.32681E-04
2.100	-7.65363E-07	-2.48126E-01	-3.35351E-04	-3.35351E-04	-3.35351E-04
2.200	-5.06355E-07	-2.55289E-01	-2.98816E-04	-2.98816E-04	-2.98816E-04
2.300	-2.92609E-07	-2.71515E-01	-2.34310E-04	-2.34310E-04	-2.34310E-04
2.400	-1.40261E-07	-2.87642E-01	-1.62365E-04	-1.62365E-04	-1.62365E-04
2.500	-8.42543E-08	-2.93655E-01	-1.05464E-04	-1.05464E-04	-1.05464E-04
2.600	-9.09515E-08	-2.82320E-01	-8.00088E-05	-8.00088E-05	-8.00088E-05
2.700	-1.04288E-07	-2.51826E-01	-9.04718E-05	-9.04718E-05	-9.04718E-05
2.800	-1.04423E-07	-2.06479E-01	-1.27848E-04	-1.27848E-04	-1.27848E-04
2.900	-7.64656E-08	-1.55220E-01	-1.72938E-04	-1.72938E-04	-1.72938E-04
3.000	-8.70546E-09	-1.08479E-01	-2.03300E-04	-2.03300E-04	-2.03300E-04
3.100	7.33977E-08	-7.45040E-02	-2.01354E-04	-2.01354E-04	-2.01354E-04
3.200	1.25847E-07	-5.64873E-02	-1.60750E-04	-1.60750E-04	-1.60750E-04
3.300	1.19456E-07	-5.15018E-02	-8.86995E-05	-8.86995E-05	-8.86995E-05
3.400	3.83086E-08	-5.16429E-02	-3.44990E-06	-3.44989E-06	-3.44989E-06
3.500	-1.17772E-07	-4.69564E-02	7.22006E-05	7.22006E-05	7.22006E-05
3.600	-3.19809E-07	-2.91009E-02	1.19012E-04	1.19012E-04	1.19012E-04
3.700	-5.20078E-07	5.56919E-03	1.28127E-04	1.28127E-04	1.28127E-04
3.800	-6.74427E-07	5.46068E-02	1.04173E-04	1.04173E-04	1.04173E-04
3.900	-7.52093E-07	1.10263E-01	6.35157E-05	6.35157E-05	6.35157E-05
4.000	-7.42814E-07	1.62178E-01	2.83114E-05	2.83114E-05	2.83114E-05
4.100	-6.63981E-07	2.01015E-01	1.84869E-05	1.84869E-05	1.84869E-05
4.200	-5.53891E-07	2.21717E-01	4.45252E-05	4.45252E-05	4.45252E-05
4.300	-4.55242E-07	2.25244E-01	1.03648E-04	1.03648E-04	1.03648E-04
4.400	-4.01785E-07	2.18141E-01	1.80763E-04	1.80763E-04	1.80763E-04
4.500	-4.08536E-07	2.10119E-01	2.53825E-04	2.53825E-04	2.53825E-04
4.600	-4.66154E-07	2.10502E-01	3.01702E-04	3.01702E-04	3.01702E-04
4.700	-5.45704E-07	2.24824E-01	3.11706E-04	3.11706E-04	3.11706E-04
4.800	-6.11903E-07	2.52795E-01	2.84096E-04	2.84096E-04	2.84096E-04
4.900	-6.37099E-07	2.88364E-01	2.31942E-04	2.31942E-04	2.31942E-04
5.000	-6.12176E-07	3.21856E-01	1.76401E-04	1.76401E-04	1.76401E-04
5.100	-5.51748E-07	3.43420E-01	1.39097E-04	1.39097E-04	1.39097E-04
5.200	-4.90112E-07	3.46537E-01	1.34349E-04	1.34349E-04	1.34349E-04
5.300	-4.69106E-07	3.30352E-01	1.64034E-04	1.64034E-04	1.64034E-04
5.400	-5.23377E-07	2.99969E-01	2.16917E-04	2.16917E-04	2.16917E-04

Contrails

RUN NO 1

PAGE NO 5

TIME SEC	VX IN/SEC	VY IN/SEC	VZ IN/SEC	OMEGAX RAD/SEC	OMEGAY RAD/SEC	OMEGAZ RAD/SEC
5.500	-1.1063E-03	-2.2509E-14	2.5915E-01	4.4642E-12	8.2793E-04	-4.4481E-16
5.600	-1.1278E-03	9.5557E-14	2.5915E-01	4.8925E-12	8.2793E-04	-6.1358E-16
5.700	-1.1492E-03	2.2331E-13	2.5915E-01	5.1620E-12	8.2793E-04	-1.0278E-15
5.800	-1.1707E-03	3.5701E-13	2.5915E-01	5.2801E-12	8.2793E-04	-1.3757E-15
5.900	-1.1921E-03	4.9277E-13	2.5915E-01	5.2323E-12	8.2793E-04	-1.5837E-15
6.000	-1.2136E-03	6.2622E-13	2.5915E-01	5.0064E-12	8.2793E-04	-1.7126E-15
6.100	-1.2350E-03	7.5279E-13	2.5915E-01	4.6192E-12	8.2793E-04	-2.4275E-15
6.200	-1.2565E-03	8.6870E-13	2.5915E-01	4.1327E-12	8.2793E-04	-2.5367E-15
6.300	-1.2780E-03	9.7221E-13	2.5915E-01	3.6498E-12	8.2793E-04	-3.2306E-15
6.400	-1.2994E-03	1.0645E-12	2.5915E-01	3.2924E-12	8.2793E-04	-3.2306E-15
6.500	-1.3209E-03	1.1499E-12	2.5915E-01	3.1675E-12	8.2793E-04	-3.5783E-15
6.600	-1.3423E-03	1.2350E-12	2.5915E-01	3.3346E-12	8.2793E-04	-3.8485E-15
6.700	-1.3638E-03	1.3275E-12	2.5915E-01	3.7855E-12	8.2793E-04	-4.1937E-15
6.800	-1.3852E-03	1.4341E-12	2.5915E-01	4.4440E-12	8.2793E-04	-4.5000E-15
6.900	-1.4067E-03	1.5588E-12	2.5915E-01	5.1849E-12	8.2793E-04	-4.9100E-15
7.000	-1.4281E-03	1.7023E-12	2.5915E-01	5.8663E-12	8.2793E-04	-5.2679E-15
7.100	-1.4496E-03	1.8615E-12	2.5915E-01	6.3606E-12	8.2793E-04	-5.8763E-15
7.200	-1.4711E-03	2.0304E-12	2.5915E-01	6.5740E-12	8.2793E-04	-6.3427E-15
7.300	-1.4925E-03	2.2011E-12	2.5915E-01	6.4477E-12	8.2793E-04	-6.7648E-15
7.400	-1.5140E-03	2.3643E-12	2.5915E-01	5.9449E-12	8.2793E-04	-7.1276E-15
7.500	-1.5354E-03	2.5102E-12	2.5915E-01	5.0353E-12	8.2793E-04	-7.6125E-15
7.600	-1.5569E-03	2.6279E-12	2.5915E-01	3.6907E-12	8.2793E-04	-7.6901E-15
7.700	-1.5783E-03	2.7061E-12	2.5915E-01	1.9010E-12	8.2793E-04	-7.7995E-15
7.800	-1.5998E-03	2.7333E-12	2.5915E-01	-2.9491E-13	8.2793E-04	-7.7767E-15
7.900	-1.6212E-03	2.6998E-12	2.5915E-01	-2.7789E-12	8.2793E-04	-7.7494E-15
8.000	-1.6427E-03	2.6001E-12	2.5915E-01	-5.3425E-12	8.2793E-04	-7.4653E-15
8.100	-1.6642E-03	2.4347E-12	2.5915E-01	-7.7097E-12	8.2793E-04	-6.6590E-15
8.200	-1.6856E-03	2.2117E-12	2.5915E-01	-9.5913E-12	8.2793E-04	-6.4151E-15
8.300	-1.7071E-03	1.9467E-12	2.5915E-01	-1.0757E-11	8.2793E-04	-5.5013E-15
8.400	-1.7285E-03	1.6602E-12	2.5915E-01	-1.1088E-11	8.2793E-04	-4.8533E-15
8.500	-1.7500E-03	1.3742E-12	2.5915E-01	-1.0602E-11	8.2793E-04	-4.2754E-15
8.600	-1.7714E-03	1.1092E-12	2.5915E-01	-9.4340E-12	8.2793E-04	-3.3279E-15
8.700	-1.7929E-03	8.8086E-13	2.5915E-01	-7.7811E-12	8.2793E-04	-3.0305E-15
8.800	-1.8144E-03	6.9961E-13	2.5915E-01	-5.8420E-12	8.2793E-04	-2.3355E-15
8.900	-1.8358E-03	5.7088E-13	2.5915E-01	-3.7730E-12	8.2793E-04	-1.7965E-15
9.000	-1.8573E-03	4.9661E-13	2.5915E-01	-1.6762E-12	8.2793E-04	-1.4478E-15
9.100	-1.8787E-03	4.7660E-13	2.5915E-01	3.8426E-13	8.2793E-04	-1.4530E-15
9.200	-1.9002E-03	5.0922E-13	2.5915E-01	2.3505E-12	8.2793E-04	-1.4251E-15
9.300	-1.9216E-03	5.9128E-13	2.5915E-01	4.1468E-12	8.2793E-04	-1.9335E-15
9.400	-1.9431E-03	7.1739E-13	2.5915E-01	5.6755E-12	8.2793E-04	-2.1952E-15
9.500	-1.9645E-03	8.7944E-13	2.5915E-01	6.8351E-12	8.2793E-04	-2.6481E-15
9.600	-1.9860E-03	1.0669E-12	2.5915E-01	7.5506E-12	8.2793E-04	-3.1835E-15
9.700	-2.0074E-03	1.2675E-12	2.5914E-01	7.7993E-12	8.2793E-04	-3.6974E-15
9.800	-2.0289E-03	1.4694E-12	2.5914E-01	7.6212E-12	8.2793E-04	-4.3354E-15
9.900	-2.0504E-03	1.6620E-12	2.5914E-01	7.1085E-12	8.2793E-04	-4.8603E-15
10.000	-2.0718E-03	1.8379E-12	2.5914E-01	6.3795E-12	8.2793E-04	-5.4708E-15
10.100	-2.0933E-03	1.9927E-12	2.5914E-01	5.5483E-12	8.2793E-04	-6.0367E-15
10.200	-2.1147E-03	2.1250E-12	2.5914E-01	4.7020E-12	8.2793E-04	-6.5481E-15
10.300	-2.1362E-03	2.2352E-12	2.5914E-01	3.8910E-12	8.2793E-04	-6.9582E-15
10.400	-2.1576E-03	2.3249E-12	2.5914E-01	3.1347E-12	8.2793E-04	-7.4263E-15
10.500	-2.1791E-03	2.3957E-12	2.5914E-01	2.4368E-12	8.2793E-04	-7.6085E-15
10.600	-2.2005E-03	2.4494E-12	2.5914E-01	1.8011E-12	8.2793E-04	-7.8365E-15
10.700	-2.2220E-03	2.4880E-12	2.5914E-01	1.2409E-12	8.2793E-04	-8.0664E-15
10.800	-2.2435E-03	2.5136E-12	2.5914E-01	7.7566E-13	8.2793E-04	-8.1879E-15
10.900	-2.2649E-03	2.5291E-12	2.5914E-01	4.1751E-13	8.2793E-04	-7.7958E-15

Contrails

RUN NO 1

PAGE NO 6

TIME	P- 1	P- 2	P- 3	P- 4	P- 5
5.500	2.84101E-07	9.85303E-08	-7.41550E-03	-2.94136E-12	2.09456E-06
5.600	-1.94807E-07	1.24829E-07	-7.31466E-03	-2.92895E-12	2.46840E-06
5.700	-7.55182E-07	1.44434E-07	-7.03461E-03	-2.90953E-12	2.50748E-06
5.800	-1.37751E-06	1.55195E-07	-6.56405E-03	-2.83374E-12	2.17280E-06
5.900	-2.03720E-06	1.55531E-07	-5.93860E-03	-2.61616E-12	1.55443E-06
6.000	-2.70247E-06	1.44749E-07	-5.22926E-03	-2.20532E-12	8.40327E-07
6.100	-3.33429E-06	1.23221E-07	-4.51829E-03	-1.71896E-12	2.47352E-07
6.200	-3.88913E-06	9.23636E-08	-3.87129E-03	-1.21338E-12	-5.43677E-08
6.300	-4.32425E-06	5.44403E-08	-3.31542E-03	-7.99989E-13	-2.98040E-09
6.400	-4.60428E-06	1.22234E-08	-2.83155E-03	-5.31255E-13	3.33603E-07
6.500	-4.70723E-06	-3.13679E-08	-2.36318E-03	-4.53732E-13	7.82613E-07
6.600	-4.62832E-06	-7.35736E-08	-1.83883E-03	-4.99206E-13	1.12894E-06
6.700	-4.38029E-06	-1.11973E-07	-1.19989E-03	-5.94271E-13	1.19282E-06
6.800	-3.99046E-06	-1.44525E-07	-4.23885E-04	-6.47324E-13	8.94813E-07
6.900	-3.49517E-06	-1.69512E-07	4.65145E-04	-6.41315E-13	2.84718E-07
7.000	-2.93358E-06	-1.85456E-07	1.40300E-03	-5.30768E-13	-4.75821E-07
7.100	-2.34244E-06	-1.91086E-07	2.30603E-03	-2.69938E-13	-1.17086E-06
7.200	-1.75325E-06	-1.85417E-07	3.09883E-03	9.54296E-14	-1.60715E-06
7.300	-1.19207E-06	-1.67931E-07	3.73899E-03	3.94480E-13	-1.68287E-06
7.400	-6.81428E-07	-1.38820E-07	4.23009E-03	6.26753E-13	-1.42366E-06
7.500	-2.42838E-07	-9.92096E-08	4.61825E-03	7.01204E-13	-9.72788E-07
7.600	1.01558E-07	-5.12583E-08	4.97346E-03	6.22801E-13	-5.39266E-07
7.700	3.29500E-07	1.91518E-09	5.36263E-03	4.39467E-13	-3.22367E-07
7.800	4.21476E-07	5.65009E-08	5.82373E-03	2.59922E-13	-4.39765E-07
7.900	3.65279E-07	1.08414E-07	6.35059E-03	2.59922E-13	-8.85015E-07
8.000	1.60727E-07	1.53767E-07	6.89371E-03	5.13173E-13	-1.52962E-06
8.100	-1.77160E-07	1.89298E-07	7.37672E-03	1.00739E-12	-2.16892E-06
8.200	-6.17893E-07	2.12658E-07	7.72273E-03	1.65651E-12	-2.59531E-06
8.300	-1.11864E-06	2.22519E-07	7.88102E-03	2.35593E-12	-2.67251E-06
8.400	-1.63012E-06	2.18513E-07	7.84455E-03	2.96667E-12	-2.38426E-06
8.500	-2.10383E-06	2.01068E-07	7.65200E-03	3.34974E-12	-1.83993E-06
8.600	-2.49859E-06	1.71223E-07	7.37362E-03	3.48917E-12	-1.23521E-06
8.700	-2.78496E-06	1.30492E-07	7.08600E-03	3.40691E-12	-7.81793E-07
8.800	-2.94641E-06	8.08276E-08	6.84482E-03	3.19358E-12	-6.31504E-07
8.900	-2.97766E-06	2.46601E-08	6.66531E-03	2.95992E-12	-8.21988E-07
9.000	-2.88112E-06	-3.50362E-08	6.51749E-03	2.81739E-12	-1.26342E-06
9.100	-2.66317E-06	-9.47375E-08	6.33781E-03	2.82278E-12	-1.77102E-06
9.200	-2.33183E-06	-1.50488E-07	6.05302E-03	2.94306E-12	-2.13162E-06
9.300	-1.89662E-06	-1.98177E-07	5.60774E-03	3.05358E-12	-2.18047E-06
9.400	-1.37046E-06	-2.33942E-07	4.98577E-03	3.00053E-12	-1.86057E-06
9.500	-7.72741E-07	-2.54639E-07	4.21744E-03	2.68979E-12	-1.24348E-06
9.600	-1.31876E-07	-2.58258E-07	3.37052E-03	2.06830E-12	-5.03870E-07
9.700	5.14203E-07	-2.44197E-07	2.52775E-03	1.34227E-12	1.42690E-07
9.800	1.12037E-06	-2.13327E-07	1.75922E-03	5.26866E-13	5.16684E-07
9.900	1.63937E-06	-1.67841E-07	1.09933E-03	-1.48651E-13	5.38511E-07
10.000	2.02857E-06	-1.10940E-07	5.36718E-04	-5.81771E-13	2.56480E-07
10.100	2.25650E-06	-4.64413E-08	2.06224E-05	-6.78405E-13	-1.71130E-07
10.200	2.30750E-06	2.15942E-08	-5.18554E-04	-4.96181E-13	-5.33433E-07
10.300	2.18322E-06	8.91347E-08	-1.14193E-03	-2.20002E-13	-6.43152E-07
10.400	1.90060E-06	1.52336E-07	-1.87791E-03	1.18109E-14	-4.04300E-07
10.500	1.48730E-06	2.07601E-07	-2.70967E-03	8.38126E-14	1.52929E-07
10.600	9.76013E-07	2.51613E-07	-3.57900E-03	-1.01876E-13	8.82568E-07
10.700	3.99431E-07	2.81404E-07	-4.40497E-03	-4.58095E-13	1.57482E-06
10.800	-2.12645E-07	2.94521E-07	-5.11089E-03	-8.90105E-13	2.03088E-06
10.900	-8.33709E-07	2.89278E-07	-5.64976E-03	-1.19549E-12	2.13379E-06

Contrails

RUN NO 1

PAGE NO 7

TIME	P- 6	P- 7	P- 8	P- 9	P-10
5.500	-6.44654E-11	-6.99664E-06	-1.24878E-06	2.64624E-01	-3.36427E-06
5.600	-8.59533E-11	1.11350E-06	-7.85241E-07	2.34385E-01	5.99094E-06
5.700	-1.02565E-10	1.08486E-05	-2.34016E-07	2.16566E-01	1.66923E-05
5.800	-1.13040E-10	2.18875E-05	4.25924E-07	2.13134E-01	2.83490E-05
5.900	-1.16482E-10	3.38068E-05	1.20461E-06	2.20049E-01	4.04881E-05
6.000	-1.12413E-10	4.60404E-05	2.08340E-06	2.28768E-01	5.25163E-05
6.100	-1.00822E-10	5.78779E-05	3.00648E-06	2.29364E-01	6.37207E-05
6.200	-8.21815E-11	6.85142E-05	3.88572E-06	2.14153E-01	7.33190E-05
6.300	-5.74374E-11	7.71453E-05	4.61803E-06	1.80518E-01	8.05565E-05
6.400	-2.79789E-11	8.30888E-05	5.10999E-06	1.31914E-01	8.48254E-05
6.500	4.43040E-12	8.58948E-05	5.30142E-06	7.67096E-02	8.57741E-05
6.600	3.77507E-11	8.54174E-05	5.18042E-06	2.52591E-02	8.33735E-05
6.700	6.97945E-11	8.18252E-05	4.78458E-06	-1.37218E-02	7.79203E-05
6.800	9.83760E-11	7.55512E-05	4.18831E-06	-3.61939E-02	6.99775E-05
6.900	1.21470E-10	6.71974E-05	3.48071E-06	-4.41487E-02	6.02684E-05
7.000	1.37363E-10	5.74267E-05	2.74169E-06	-4.47976E-02	4.95584E-05
7.100	1.44788E-10	4.68718E-05	2.02428E-06	-4.78890E-02	3.85551E-05
7.200	1.43021E-10	3.60861E-05	1.34890E-06	-6.21189E-02	2.78535E-05
7.300	1.31936E-10	2.55424E-05	7.10751E-07	-9.19218E-02	1.79316E-05
7.400	1.12025E-10	1.56666E-05	9.66442E-08	-1.35796E-01	9.18456E-06
7.500	8.43629E-11	6.88276E-06	-4.95547E-07	-1.86761E-01	1.97335E-06
7.600	5.05494E-11	-3.59581E-07	-1.04290E-06	-2.34786E-01	-3.34417E-06
7.700	1.26105E-11	-5.59747E-06	-1.49462E-06	-2.70314E-01	-6.41912E-06
7.800	-2.71166E-11	-8.40994E-06	-1.78225E-06	-2.87619E-01	-6.96096E-06
7.900	-6.61191E-11	-8.50420E-06	-1.83951E-06	-2.86791E-01	-4.81722E-06
8.000	-1.01857E-10	-5.80542E-06	-1.62517E-06	-2.73648E-01	-5.61389E-06
8.100	-1.31921E-10	-5.18522E-07	-1.14061E-06	-2.57586E-01	6.97939E-06
8.200	-1.54192E-10	6.86265E-06	-4.35744E-07	-2.48171E-01	1.56714E-05
8.300	-1.66988E-10	1.56076E-05	3.99446E-07	-2.51669E-01	2.51882E-05
8.400	-1.69206E-10	2.48524E-05	1.25510E-06	-2.68772E-01	3.45968E-05
8.500	-1.60413E-10	3.37275E-05	2.02711E-06	-2.94342E-01	4.29974E-05
8.600	-1.40905E-10	4.14754E-05	2.63978E-06	-3.19243E-01	4.96462E-05
8.700	-1.11712E-10	4.75298E-05	3.05840E-06	-3.33623E-01	5.40354E-05
8.800	-7.45435E-11	5.15397E-05	3.28818E-06	-3.30457E-01	5.50913E-05
8.900	-3.16798E-11	5.33417E-05	3.36068E-06	-3.08081E-01	5.52513E-05
9.000	1.41748E-11	5.29003E-05	3.31360E-06	-2.70812E-01	5.21717E-05
9.100	6.00725E-11	5.02465E-05	3.17154E-06	-2.27429E-01	4.68770E-05
9.200	1.03017E-10	4.54406E-05	2.93513E-06	-1.88062E-01	3.95995E-05
9.300	1.40158E-10	3.85748E-05	2.58255E-06	-1.60610E-01	3.05934E-05
9.400	1.68970E-10	2.98139E-05	2.08276E-06	-1.47964E-01	2.01656E-05
9.500	1.87420E-10	1.94542E-05	1.41541E-06	-1.47038E-01	8.72700E-06
9.600	1.94092E-10	7.97353E-06	5.89625E-07	-1.49949E-01	-3.16411E-06
9.700	1.88290E-10	-3.95731E-06	-3.45613E-07	-1.46924E-01	-1.47953E-05
9.800	1.70099E-10	-1.55149E-05	-1.30425E-06	-1.29890E-01	-2.53439E-05
9.900	1.40404E-10	-2.58151E-05	-2.17893E-06	-9.54449E-02	-3.39714E-05
10.000	1.00859E-10	-3.40353E-05	-2.86503E-06	-4.61706E-02	-3.99449E-05
10.100	5.38111E-11	-3.95364E-05	-3.28536E-06	1.02131E-02	-4.27562E-05
10.200	2.16375E-12	-4.19501E-05	-3.40730E-06	6.35278E-02	-4.22026E-05
10.300	-5.07968E-11	-4.12110E-05	-3.24710E-06	1.04697E-01	-3.84091E-05
10.400	-1.01617E-10	-3.75273E-05	-2.86011E-06	1.28910E-01	-3.17860E-05
10.500	-1.46912E-10	-3.13037E-05	-2.32080E-06	1.37250E-01	-2.29370E-05
10.600	-1.83598E-10	-2.30457E-05	-1.69972E-06	1.36218E-01	-1.25487E-05
10.700	-2.09110E-10	-1.32749E-05	-1.04541E-06	1.35303E-01	-1.29204E-06
10.800	-2.21586E-10	-2.48100E-06	-3.77379E-07	1.43498E-01	1.02360E-05
10.900	-2.19990E-10	8.88147E-06	3.08129E-07	1.65993E-01	2.15232E-05

Contrails

RUN NO 1

PAGE NO 8

TIME	P-11	P-12	P-13	P-14	P-15
5.500	-6.67896E-07	2.64624E-01	2.72697E-04	2.72697E-04	
5.600	-8.91625E-07	2.34385E-01	3.09309E-04	3.09309E-04	
5.700	-1.16014E-06	2.16566E-01	3.10854E-04	3.10854E-04	
5.800	-1.42657E-06	2.13134E-01	2.73329E-04	2.73329E-04	
5.900	-1.64648E-06	2.20049E-01	2.06082E-04	2.06082E-04	
6.000	-1.79164E-06	2.28768E-01	1.28490E-04	1.28490E-04	
6.100	-1.89805E-06	2.29364E-01	6.30434E-05	6.30434E-05	
6.200	-1.88540E-06	2.14153E-01	2.73277E-05	2.73277E-05	
6.300	-1.84807E-06	1.80518E-01	2.77712E-05	2.77712E-05	
6.400	-1.84121E-06	1.31914E-01	5.74063E-05	5.74063E-05	
6.500	-1.86712E-06	7.67096E-02	9.84397E-05	9.84398E-05	
6.600	-1.92652E-06	2.52591E-02	1.28709E-04	1.28709E-04	
6.700	-1.99817E-06	-1.37218E-02	1.29701E-04	1.29701E-04	
6.800	-2.04687E-06	-3.61939E-02	9.32649E-05	9.32649E-05	
6.900	-2.03695E-06	-4.41487E-02	2.45950E-05	2.45950E-05	
7.000	-1.94630E-06	-4.47976E-02	-5.95654E-05	-5.95654E-05	
7.100	-1.77596E-06	-4.78890E-02	-1.36867E-04	-1.36867E-04	
7.200	-1.55155E-06	-6.21189E-02	-1.87303E-04	-1.87303E-04	
7.300	-1.31606E-06	-9.19218E-02	-2.00312E-04	-2.00312E-04	
7.400	-1.11639E-06	-1.35796E-01	-1.78492E-04	-1.78492E-04	
7.500	-9.88383E-07	-1.86761E-01	-1.36593E-04	-1.36593E-04	
7.600	-9.45558E-07	-2.34786E-01	-9.61537E-05	-9.61537E-05	
7.700	-9.75564E-07	-2.70314E-01	-7.77113E-05	-7.77113E-05	
7.800	-1.04548E-06	-2.87619E-01	-9.33807E-05	-9.33807E-05	
7.900	-1.11402E-06	-2.86791E-01	-1.42464E-04	-1.42464E-04	
8.000	-1.14626E-06	-2.73648E-01	-2.11663E-04	-2.11663E-04	
8.100	-1.12564E-06	-2.57586E-01	-2.79822E-04	-2.79822E-04	
8.200	-1.05890E-06	-2.48171E-01	-3.25484E-04	-3.25484E-04	
8.300	-9.72354E-07	-2.51669E-01	-3.34561E-04	-3.34561E-04	
8.400	-9.00906E-07	-2.68772E-01	-3.05364E-04	-3.05364E-04	
8.500	-8.73837E-07	-2.94342E-01	-2.49183E-04	-2.49183E-04	
8.600	-9.02629E-07	-3.19243E-01	-1.86222E-04	-1.86222E-04	
8.700	-9.75280E-07	-3.33623E-01	-1.38345E-04	-1.38345E-04	
8.800	-1.05929E-06	-3.30457E-01	-1.21242E-04	-1.21242E-04	
8.900	-1.11233E-06	-3.08081E-01	-1.38812E-04	-1.38812E-04	
9.000	-1.09680E-06	-2.70812E-01	-1.81800E-04	-1.81800E-04	
9.100	-9.93210E-07	-2.27429E-01	-2.31149E-04	-2.31149E-04	
9.200	-8.07445E-07	-1.88062E-01	-2.64877E-04	-2.64877E-04	
9.300	-5.69491E-07	-1.60610E-01	-2.66002E-04	-2.66002E-04	
9.400	-3.23869E-07	-1.47964E-01	-2.28677E-04	-2.28677E-04	
9.500	-1.15271E-07	-1.47038E-01	-1.60328E-04	-1.60328E-04	
9.600	2.56106E-08	-1.49949E-01	-7.90350E-05	-7.90350E-05	
9.700	9.10644E-08	-1.46924E-01	-7.10242E-06	-7.10240E-06	
9.800	9.70598E-08	-1.29890E-01	3.68855E-05	3.68855E-05	
9.900	7.55386E-08	-9.54449E-02	4.46601E-05	4.46601E-05	
10.000	6.12181E-08	-4.61706E-02	2.11588E-05	2.11587E-05	
10.100	7.77207E-08	1.02131E-02	-1.73259E-05	-1.73259E-05	
10.200	1.28102E-07	6.35278E-02	-4.90703E-05	-4.90703E-05	
10.300	1.93253E-07	1.04697E-01	-5.47883E-05	-5.47882E-05	
10.400	2.38756E-07	1.28910E-01	-2.46197E-05	-2.46197E-05	
10.500	2.27739E-07	1.37250E-01	3.82670E-05	3.82671E-05	
10.600	1.35082E-07	1.36218E-01	1.18751E-04	1.18751E-04	
10.700	-4.21761E-08	1.35303E-01	1.95120E-04	1.95120E-04	
10.800	-2.82057E-07	1.43498E-01	2.46803E-04	2.46803E-04	
10.900	-5.43580E-07	1.65993E-01	2.61678E-04	2.61678E-04	

Contrails

RUN NO 1

PAGE NO 9

TIME SEC	WX IN/SEC	VY IN/SEC	VZ IN/SEC	OMEGAX RAD/SEC	OMEGAY RAD/SEC	OMEGAZ RAD/SEC
11.000	-2.2864E-03	2.5373E-12	2.5914E-01	1.5380E-13	8.2793E-04	-7.9222E-15
11.100	-2.3078E-03	2.5404E-12	2.5914E-01	-6.2820E-14	8.2793E-04	-7.9286E-15
11.200	+2.3293E-03	2.5388E-12	2.5914E-01	-3.0798E-13	8.2793E-04	-7.7255E-15
11.300	-2.3507E-03	2.5310E-12	2.5914E-01	-6.6043E-13	8.2793E-04	-7.8189E-15
11.400	-2.3722E-03	2.5132E-12	2.5914E-01	-1.1655E-12	8.2793E-04	-7.5633E-15
11.500	-2.3936E-03	2.4811E-12	2.5914E-01	-1.8028E-12	8.2793E-04	-7.5140E-15
11.600	-2.4151E-03	2.4317E-12	2.5914E-01	-2.4756E-12	8.2793E-04	-7.4419E-15
11.700	-2.4366E-03	2.3649E-12	2.5914E-01	-3.0319E-12	8.2793E-04	-7.3525E-15
11.800	-2.4580E-03	2.2853E-12	2.5914E-01	-3.3124E-12	8.2793E-04	-7.3803E-15
11.900	-2.4795E-03	2.2012E-12	2.5914E-01	-3.2102E-12	8.2793E-04	-6.9123E-15
12.000	-2.5009E-03	2.1227E-12	2.5914E-01	-2.7147E-12	8.2793E-04	-6.8990E-15
12.100	-2.5224E-03	2.0596E-12	2.5914E-01	-1.9223E-12	8.2793E-04	-6.5475E-15
12.200	-2.5438E-03	2.0180E-12	2.5914E-01	-1.0067E-12	8.2793E-04	-6.6394E-15
12.300	-2.5653E-03	1.9992E-12	2.5914E-01	-1.6281E-13	8.2793E-04	-6.8507E-15
12.400	-2.5867E-03	1.9995E-12	2.5914E-01	4.5266E-13	8.2793E-04	-6.5981E-15
12.500	-2.6082E-03	2.0120E-12	2.5914E-01	7.5943E-13	8.2793E-04	-6.8672E-15
12.600	-2.6296E-03	2.0287E-12	2.5914E-01	7.5729E-13	8.2793E-04	-6.9880E-15
12.700	-2.6511E-03	2.0422E-12	2.5914E-01	5.0036E-13	8.2793E-04	-6.8645E-15
12.800	-2.6726E-03	2.0468E-12	2.5914E-01	5.9588E-14	8.2793E-04	-6.7431E-15
12.900	-2.6940E-03	2.0387E-12	2.5914E-01	-5.0511E-13	8.2793E-04	-6.6153E-15
13.000	-2.7155E-03	2.0156E-12	2.5914E-01	-1.1500E-12	8.2793E-04	-6.4768E-15
13.100	-2.7369E-03	1.9758E-12	2.5914E-01	-1.8314E-12	8.2793E-04	-6.2967E-15
13.200	-2.7584E-03	1.9193E-12	2.5914E-01	-2.4815E-12	8.2793E-04	-6.0512E-15
13.300	-2.7798E-03	1.8478E-12	2.5914E-01	-2.9943E-12	8.2793E-04	-5.8672E-15
13.400	-2.8013E-03	1.7663E-12	2.5914E-01	-3.2334E-12	8.2793E-04	-5.7156E-15
13.500	-2.8227E-03	1.6833E-12	2.5914E-01	-3.0611E-12	8.2793E-04	-5.6917E-15
13.600	-2.8442E-03	1.6107E-12	2.5914E-01	-2.3777E-12	8.2793E-04	-5.5423E-15
13.700	-2.8657E-03	1.5621E-12	2.5914E-01	-1.1544E-12	8.2793E-04	-5.5475E-15
13.800	-2.8871E-03	1.5513E-12	2.5914E-01	5.5361E-13	8.2793E-04	-5.4701E-15
13.900	-2.9086E-03	1.5895E-12	2.5914E-01	2.6183E-12	8.2793E-04	-5.5841E-15
14.000	-2.9300E-03	1.6840E-12	2.5914E-01	4.8678E-12	8.2793E-04	-5.9227E-15
14.100	-2.9515E-03	1.8375E-12	2.5914E-01	7.1215E-12	8.2793E-04	-6.1712E-15
14.200	-2.9729E-03	2.0479E-12	2.5914E-01	9.2175E-12	8.2793E-04	-6.7389E-15
14.300	-2.9944E-03	2.3096E-12	2.5913E-01	1.1025E-11	8.2793E-04	-7.5287E-15
14.400	-3.0158E-03	2.6137E-12	2.5913E-01	1.2442E-11	8.2793E-04	-7.9922E-15
14.500	-3.0373E-03	2.9491E-12	2.5913E-01	1.3376E-11	8.2793E-04	-9.0590E-15
14.600	-3.0587E-03	3.3025E-12	2.5913E-01	1.3737E-11	8.2793E-04	-1.0114E-14
14.700	-3.0802E-03	3.6580E-12	2.5913E-01	1.3432E-11	8.2793E-04	-1.0829E-14
14.800	-3.1017E-03	3.9976E-12	2.5913E-01	1.2376E-11	8.2793E-04	-1.1822E-14
14.900	-3.1231E-03	4.3012E-12	2.5913E-01	1.0529E-11	8.2793E-04	-1.2522E-14
15.000	-3.1446E-03	4.5484E-12	2.5913E-01	7.9281E-12	8.2793E-04	-1.2959E-14
15.100	-3.1660E-03	4.7207E-12	2.5913E-01	4.7134E-12	8.2793E-04	-1.3765E-14
15.200	-3.1875E-03	4.8043E-12	2.5913E-01	1.1306E-12	8.2793E-04	-1.3636E-14
15.300	-3.2089E-03	4.7930E-12	2.5913E-01	-2.4997E-12	8.2793E-04	-1.3676E-14
15.400	-3.2304E-03	4.6692E-12	2.5913E-01	-5.8393E-12	8.2793E-04	-1.3589E-14
15.500	-3.2518E-03	4.5040E-12	2.5913E-01	-8.5986E-12	8.2793E-04	-1.3173E-14
15.600	-3.2733E-03	4.2551E-12	2.5913E-01	-1.0591E-11	8.2793E-04	-1.2340E-14
15.700	-3.2947E-03	3.9639E-12	2.5913E-01	-1.1752E-11	8.2793E-04	-1.1739E-14
15.800	-3.3162E-03	3.6517E-12	2.5913E-01	-1.2131E-11	8.2793E-04	-1.0961E-14
15.900	-3.3377E-03	3.3384E-12	2.5913E-01	-1.1839E-11	8.2793E-04	-1.0018E-14
16.000	-3.3591E-03	3.0397E-12	2.5913E-01	-1.1008E-11	8.2793E-04	-9.2113E-15
16.100	-3.3806E-03	2.7682E-12	2.5913E-01	-9.7545E-12	8.2793E-04	-8.4413E-15
16.200	-3.4020E-03	2.5337E-12	2.5913E-01	-8.1737E-12	8.2793E-04	-7.4610E-15
16.300	-3.4235E-03	2.3435E-12	2.5913E-01	-6.3530E-12	8.2793E-04	-7.0559E-15
16.400	-3.4449E-03	2.2028E-12	2.5913E-01	-4.3957E-12	8.2793E-04	-6.7354E-15

Contrails

RUN NO 1

PAGE NO 10

TIME	P- 1	P- 2	P- 3	P- 4	P- 5
11.000	-1.43890E-06	2.65064E-07	-6.01927E-03	-1.26899E-12	1.88988E-06
11.100	-2.00262E-06	2.22618E-07	-6.26080E-03	-1.06180E-12	1.42607E-06
11.200	-2.49697E-06	1.64165E-07	-6.44298E-03	-6.33282E-13	9.43837E-07
11.300	-2.89227E-06	9.33610E-08	-6.63560E-03	-1.06655E-13	6.46633E-07
11.400	-3.16006E-06	1.50127E-08	-6.88339E-03	3.35709E-13	6.66581E-07
11.500	-3.27794E-06	-6.53814E-08	-7.18888E-03	5.71771E-13	1.01692E-06
11.600	-3.23490E-06	-1.42188E-07	-7.51074E-03	4.81932E-13	1.58714E-06
11.700	-3.03533E-06	-2.10176E-07	-7.77798E-03	2.98640E-14	2.18257E-06
11.800	-2.70029E-06	-2.64946E-07	-7.91503E-03	-6.88420E-13	2.59418E-06
11.900	-2.26335E-06	-3.03181E-07	-7.86867E-03	-1.48564E-12	2.67352E-06
12.000	-1.77539E-06	-3.22723E-07	-7.62714E-03	-2.14156E-12	2.38593E-06
12.100	-1.27781E-06	-3.22528E-07	-7.22459E-03	-2.49242E-12	1.82297E-06
12.200	-8.15870E-07	-3.02564E-07	-6.72929E-03	-2.49621E-12	1.16958E-06
12.300	-4.23896E-07	-2.63734E-07	-6.21979E-03	-2.20441E-12	6.37846E-07
12.400	-1.25394E-07	-2.07855E-07	-5.75769E-03	-1.75045E-12	3.91105E-07
12.500	6.59849E-08	-1.37699E-07	-5.36663E-03	-1.34274E-12	4.85645E-07
12.600	1.43570E-07	-5.70321E-08	-5.02516E-03	-1.17362E-12	8.50880E-07
12.700	1.04445E-07	2.94173E-08	-4.67594E-03	-1.30594E-12	1.31509E-06
12.800	-5.25983E-08	1.16136E-07	-4.24798E-03	-1.68340E-12	1.66747E-06
12.900	-3.26989E-07	1.97174E-07	-3.68394E-03	-2.05196E-12	1.73416E-06
13.000	-7.14172E-07	2.66646E-07	-2.96257E-03	-2.26261E-12	1.44104E-06
13.100	-1.20221E-06	3.19316E-07	-2.10844E-03	-2.09430E-12	8.40689E-07
13.200	-1.76874E-06	3.51142E-07	-1.18514E-03	-1.48039E-12	9.39383E-08
13.300	-2.37980E-06	3.59697E-07	-2.74780E-04	-5.74681E-13	-5.87401E-07
13.400	-2.99161E-06	3.44360E-07	-5.49277E-04	4.94625E-13	-1.01603E-06
13.500	-3.55523E-06	3.06287E-07	1.24635E-03	1.47076E-12	-1.09582E-06
13.600	-4.02321E-06	2.48164E-07	1.82069E-03	2.15020E-12	-8.55674E-07
13.700	-4.35653E-06	1.73859E-07	2.31760E-03	2.38169E-12	-4.38577E-07
13.800	-4.52996E-06	8.80344E-08	2.80482E-03	2.17562E-12	-4.96915E-08
13.900	-4.53449E-06	-4.17529E-09	3.34599E-03	1.62313E-12	1.17782E-07
14.000	-4.37641E-06	-9.74061E-08	3.97563E-03	1.01458E-12	-4.76108E-08
14.100	-4.07363E-06	-1.86227E-07	4.69466E-03	5.57612E-13	-5.35180E-07
14.200	-3.65062E-06	-2.65284E-07	5.42173E-03	3.49186E-13	-1.21557E-06
14.300	-3.13381E-06	-3.29485E-07	6.10978E-03	3.64345E-13	-1.88680E-06
14.400	-2.54870E-06	-3.74277E-07	6.67199E-03	5.24156E-13	-2.34642E-06
14.500	-1.91946E-06	-3.96012E-07	7.05778E-03	5.56791E-13	-2.46374E-06
14.600	-1.27042E-06	-3.92369E-07	7.25953E-03	5.43944E-13	-2.22636E-06
14.700	-6.28549E-07	-3.62729E-07	7.31413E-03	7.46742E-14	-1.74426E-06
14.800	-2.49879E-08	-3.08411E-07	7.28866E-03	-7.55957E-13	-1.21006E-06
14.900	5.05289E-07	-2.32691E-07	7.25554E-03	-1.77133E-12	-8.29654E-07
15.000	9.26466E-07	-1.40574E-07	7.26598E-03	-2.76259E-12	-7.48253E-07
15.100	1.20694E-06	-3.83373E-08	7.33125E-03	-3.46281E-12	-9.98236E-07
15.200	1.32513E-06	6.70659E-09	7.41851E-03	-3.69446E-12	-1.48759E-06
15.300	1.27432E-06	1.68628E-07	7.46276E-03	-3.42579E-12	-2.03302E-06
15.400	1.06490E-06	2.59837E-07	7.39043E-03	-2.76826E-12	-2.42584E-06
15.500	7.23259E-07	3.35079E-07	7.14633E-03	-1.91828E-12	-2.50694E-06
15.600	2.87486E-07	3.89872E-07	6.71419E-03	-1.14266E-12	-2.22402E-06
15.700	-1.98877E-07	4.20970E-07	6.12339E-03	-6.62957E-13	-1.65049E-06
15.800	-6.93342E-07	4.26395E-07	5.43959E-03	-5.53060E-13	-9.59266E-07
15.900	-1.15947E-06	4.05469E-07	4.74245E-03	-7.23590E-13	-3.61048E-07
16.000	-1.56923E-06	3.58876E-07	4.09958E-03	-1.06844E-12	-2.90030E-08
16.100	-1.90268E-06	2.88763E-07	3.53937E-03	-1.32868E-12	-3.70785E-08
16.200	-2.14555E-06	1.98811E-07	3.05154E-03	-1.34337E-12	-3.33956E-07
16.300	-2.28653E-06	9.42166E-08	2.58391E-03	-1.01715E-12	-7.61986E-07
16.400	-2.31542E-06	-1.84955E-08	2.06790E-03	-3.85074E-13	-1.11428E-06

Contrails

RUN NO 1

PAGE NO 11

TIME	P- 6	P- 7	P- 8	P- 9	P-10
11.000	-2.04189E-10	2.03619E-05	1.02230E-06	2.02240E-01	3.21137E-05
11.100	-1.74967E-10	3.14702E-05	1.76461E-06	2.46088E-01	4.15637E-05
11.200	-1.33974E-10	4.16503E-05	2.50801E-06	2.87927E-01	4.94121E-05
11.300	-8.36391E-11	5.02926E-05	3.19492E-06	3.18083E-01	5.51861E-05
11.400	-2.70245E-11	5.67921E-05	3.74607E-06	3.30239E-01	5.84527E-05
11.500	3.23500E-11	6.06415E-05	4.07998E-06	3.23657E-01	5.89022E-05
11.600	9.07163E-11	6.15335E-05	4.13643E-06	3.03405E-01	5.64405E-05
11.700	1.44289E-10	5.94402E-05	3.89602E-06	2.78513E-01	5.12558E-05
11.800	1.89505E-10	5.46424E-05	3.38881E-06	2.58711E-01	4.38351E-05
11.900	2.23266E-10	4.76976E-05	2.68889E-06	2.50936E-01	3.49179E-05
12.000	2.43156E-10	3.93522E-05	1.89640E-06	2.56843E-01	2.53948E-05
12.100	2.47622E-10	3.04233E-05	1.11298E-06	2.72226E-01	1.61775E-05
12.200	2.36103E-10	2.16816E-05	4.18678E-07	2.88552E-01	8.07250E-06
12.300	2.09089E-10	1.37666E-05	-1.42301E-07	2.96050E-01	1.69252E-06
12.400	1.68104E-10	7.15116E-06	-5.62749E-07	2.87256E-01	-2.57814E-06
12.500	1.15616E-10	2.15632E-06	-8.61151E-07	2.59727E-01	-4.56273E-06
12.600	5.48795E-11	-1.00143E-06	-1.06280E-06	2.16971E-01	-4.23444E-06
12.700	-1.02766E-11	-2.15809E-06	-1.18095E-06	1.67239E-01	-1.65093E-06
12.800	-7.56953E-11	-1.17229E-06	-1.20542E-06	1.20631E-01	3.09051E-06
12.900	-1.37157E-10	2.06575E-06	-1.10305E-06	8.55376E-02	9.85929E-06
13.000	-1.90644E-10	7.58678E-06	-8.30215E-07	6.57135E-02	1.84585E-05
13.100	-2.32596E-10	1.52740E-05	-3.52768E-07	5.90112E-02	2.85696E-05
13.200	-2.60134E-10	2.48017E-05	3.34042E-07	5.82416E-02	3.97028E-05
13.300	-2.71252E-10	3.56088E-05	1.19319E-06	5.38439E-02	5.11806E-05
13.400	-2.64958E-10	4.69272E-05	2.14624E-06	3.74072E-02	6.21743E-05
13.500	-2.41361E-10	5.78641E-05	3.08711E-06	4.77790E-03	7.17921E-05
13.600	-2.01692E-10	6.75217E-05	3.90518E-06	-4.23607E-02	7.92014E-05
13.700	-1.48256E-10	7.51245E-05	4.51043E-06	-9.70044E-02	8.37546E-05
13.800	-8.43032E-11	8.01199E-05	4.85249E-06	-1.49253E-01	8.50841E-05
13.900	-1.38365E-11	8.22284E-05	4.92766E-06	-1.89776E-01	8.31408E-05
14.000	5.86434E-11	8.14339E-05	4.77200E-06	-2.13069E-01	7.81703E-05
14.100	1.28434E-10	7.79258E-05	4.44361E-06	-2.19348E-01	7.06362E-05
14.200	1.90947E-10	7.20168E-05	4.00077E-06	-2.14383E-01	6.11184E-05
14.300	2.42015E-10	6.40680E-05	3.48372E-06	-2.07359E-01	5.02195E-05
14.400	2.78177E-10	5.44451E-05	2.90658E-06	-2.07502E-01	3.85041E-05
14.500	2.96904E-10	4.35167E-05	2.26197E-06	-2.20716E-01	2.64843E-05
14.600	2.96767E-10	3.16870E-05	1.53578E-06	-2.47407E-01	1.46444E-05
14.700	2.77536E-10	1.94415E-05	7.26385E-07	-2.82299E-01	3.48120E-06
14.800	2.40195E-10	7.37659E-06	-1.39735E-07	-3.16286E-01	-6.46529E-06
14.900	1.86898E-10	-3.80940E-06	-1.00242E-06	-3.39673E-01	-1.46181E-05
15.000	1.20839E-10	-1.33737E-05	-1.77523E-06	-3.45631E-01	-2.04138E-05
15.100	4.60763E-11	-2.06258E-05	-2.36406E-06	-3.32628E-01	-2.33902E-05
15.200	-3.27111E-11	-2.50400E-05	-2.69103E-06	-3.04971E-01	-2.32864E-05
15.300	-1.10506E-10	-2.63507E-05	-2.71578E-06	-2.71262E-01	-2.01227E-05
15.400	-1.82267E-10	-2.46022E-05	-2.44676E-06	-2.41317E-01	-1.42339E-05
15.500	-2.43259E-10	-2.01379E-05	-1.93888E-06	-2.22671E-01	-6.23871E-06
15.600	-2.89371E-10	-1.35320E-05	-1.27810E-06	-2.17901E-01	3.04765E-06
15.700	-3.17402E-10	-5.48388E-06	-5.58362E-07	-2.23746E-01	1.27368E-05
15.800	-3.25293E-10	3.29276E-06	1.41471E-07	-2.32325E-01	2.19929E-05
15.900	-3.12285E-10	1.21561E-05	7.73026E-07	-2.34020E-01	3.01287E-05
16.000	-2.78978E-10	2.05777E-05	1.32151E-06	-2.20988E-01	3.66510E-05
16.100	-2.27307E-10	2.81369E-05	1.79630E-06	-1.90039E-01	4.12522E-05
16.200	-1.60420E-10	3.44822E-05	2.21340E-06	-1.43849E-01	4.37644E-05
16.300	-8.24758E-11	3.92869E-05	2.57684E-06	-9.00733E-02	4.41010E-05
16.400	1.61971E-12	4.22244E-05	2.86672E-06	-3.86806E-02	4.22171E-05

Contrails

ROW NO 1

PAGE NO 12

TIME	P-11	P-12	P-13	P-14	P-15
11.000	-7.79403E-07	2.02240E-01	2.40363E-04	2.40363E-04	
11.100	-9.50764E-07	2.46088E-01	1.95925E-04	1.95925E-04	
11.200	-1.03946E-06	2.87927E-01	1.49139E-04	1.49139E-04	
11.300	-1.05272E-06	3.18083E-01	1.20985E-04	1.20985E-04	
11.400	-1.01931E-06	3.30239E-01	1.25082E-04	1.25082E-04	
11.500	-9.78284E-07	3.23657E-01	1.62778E-04	1.62779E-04	
11.600	-9.64637E-07	3.03405E-01	2.22650E-04	2.22650E-04	
11.700	-9.96788E-07	2.78513E-01	2.84586E-04	2.84586E-04	
11.800	-1.07056E-06	2.58711E-01	3.26997E-04	3.26997E-04	
11.900	-1.16166E-06	2.50936E-01	3.34556E-04	3.34556E-04	
12.000	-1.23572E-06	2.56843E-01	3.03689E-04	3.03689E-04	
12.100	-1.26216E-06	2.72226E-01	2.43862E-04	2.43862E-04	
12.200	-1.22690E-06	2.88552E-01	1.74187E-04	1.74187E-04	
12.300	-1.13901E-06	2.96050E-01	1.16583E-04	1.16583E-04	
12.400	-1.02906E-06	2.87256E-01	8.79431E-05	8.79431E-05	
12.500	-9.39469E-07	2.59727E-01	9.41067E-05	9.41068E-05	
12.600	-9.10308E-07	2.16971E-01	1.27819E-04	1.27819E-04	
12.700	-9.65515E-07	1.67239E-01	1.71385E-04	1.71385E-04	
12.800	-1.10449E-06	1.20631E-01	2.03076E-04	2.03076E-04	
12.900	-1.30200E-06	8.55376E-02	2.04984E-04	2.04984E-04	
13.000	-1.51646E-06	6.57135E-02	1.69501E-04	1.69500E-04	
13.100	-1.70367E-06	5.90112E-02	1.02103E-04	1.02103E-04	
13.200	-1.83110E-06	5.82416E-02	1.94473E-05	1.94472E-05	
13.300	-1.88776E-06	5.38439E-02	-5.65432E-05	-5.65432E-05	
13.400	-1.88621E-06	3.74072E-02	-1.06477E-04	-1.06477E-04	
13.500	-1.85602E-06	4.77789E-03	-1.20375E-04	-1.20375E-04	
13.600	-1.83136E-06	-4.23607E-02	-1.01171E-04	-1.01171E-04	
13.700	-1.83708E-06	-9.70044E-02	-6.35771E-05	-6.35770E-05	
13.800	-1.87856E-06	-1.49253E-01	-2.87288E-05	-2.87287E-05	
13.900	-1.93888E-06	-1.89776E-01	-1.65268E-05	-1.65268E-05	
14.000	-1.98456E-06	-2.13069E-01	-3.84331E-05	-3.84331E-05	
14.100	-1.97767E-06	-2.19347E-01	-9.32995E-05	-9.32996E-05	
14.200	-1.89013E-06	-2.14383E-01	-1.67727E-04	-1.67727E-04	
14.300	-1.71480E-06	-2.07359E-01	-2.40823E-04	-2.40823E-04	
14.400	-1.46961E-06	-2.07502E-01	-2.91646E-04	-2.91646E-04	
14.500	-1.19293E-06	-2.20716E-01	-3.06669E-04	-3.06669E-04	
14.600	-9.31817E-07	-2.47407E-01	-2.84588E-04	-2.84588E-04	
14.700	-7.27297E-07	-2.82299E-01	-2.36735E-04	-2.36735E-04	
14.800	-6.81739E-07	-3.16286E-01	-1.82982E-04	-1.82982E-04	
14.900	-5.52781E-07	-3.39673E-01	-1.44578E-04	-1.44578E-04	
15.000	-5.55862E-07	-3.45631E-01	-1.36509E-04	-1.36509E-04	
15.100	-5.74339E-07	-3.32628E-01	-1.62114E-04	-1.62114E-04	
15.200	-5.73487E-07	-3.04971E-01	-2.11895E-04	-2.11895E-04	
15.300	-5.33240E-07	-2.71262E-01	-2.66932E-04	-2.66932E-04	
15.400	-4.55661E-07	-2.41318E-01	-3.05687E-04	-3.05687E-04	
15.500	-3.62802E-07	-2.22671E-01	-3.11748E-04	-3.11748E-04	
15.600	-2.88593E-07	-2.17901E-01	-2.79736E-04	-2.79736E-04	
15.700	-2.64713E-07	-2.23746E-01	-2.17255E-04	-2.17255E-04	
15.800	-3.08065E-07	-2.32325E-01	-1.42193E-04	-1.42193E-04	
15.900	-4.12646E-07	-2.34020E-01	-7.63378E-05	-7.63378E-05	
16.000	-5.50177E-07	-2.20988E-01	-3.76094E-05	-3.76095E-05	
16.100	-4.78602E-07	-1.90039E-01	-3.36841E-05	-3.36842E-05	
16.200	-7.55809E-07	-1.43849E-01	-5.93063E-05	-5.93064E-05	
16.300	-7.53693E-07	-9.00733E-02	-9.82436E-05	-9.82437E-05	
16.400	-6.67580E-07	-3.86806E-02	-1.29181E-04	-1.29181E-04	

Contrails

RUNN MED 4

PAGE NO 13

TIME SEC	WXX IN/SEC	WYY IN/SEC	WZZ IN/SEC	OMEGAX RAD/SEC	OMEGAY RAD/SEC	OMEGAZ RAD/SEC
16.500	-3.4664E-03	2.1135E-12	2.5913E-01	-2.4300E-12	8.2793E-04	-6.5360E-15
16.600	-3.4878E-03	2.0742E-12	2.5913E-01	-5.9729E-13	8.2793E-04	-6.5097E-15
16.700	-3.5093E-03	2.0799E-12	2.5913E-01	9.7841E-13	8.2793E-04	-6.6048E-15
16.800	-3.5307E-03	2.1226E-12	2.5913E-01	2.2228E-12	8.2793E-04	-6.7662E-15
16.900	-3.5522E-03	2.1930E-12	2.5913E-01	3.1290E-12	8.2793E-04	-6.9237E-15
17.000	-3.5736E-03	2.2825E-12	2.5913E-01	3.7490E-12	8.2793E-04	-7.2560E-15
17.100	-3.5951E-03	2.3842E-12	2.5913E-01	4.1624E-12	8.2793E-04	-7.5956E-15
17.200	-3.6166E-03	2.4935E-12	2.5913E-01	4.4380E-12	8.2793E-04	-8.0338E-15
17.300	-3.6380E-03	2.6076E-12	2.5913E-01	4.6054E-12	8.2793E-04	-8.5237E-15
17.400	-3.6595E-03	2.7237E-12	2.5913E-01	4.6511E-12	8.2793E-04	-8.8630E-15
17.500	-3.6809E-03	2.8387E-12	2.5913E-01	4.5375E-12	8.2793E-04	-9.5344E-15
17.600	-3.7024E-03	2.9483E-12	2.5913E-01	4.2360E-12	8.2793E-04	-9.7757E-15
17.700	-3.7238E-03	3.0479E-12	2.5913E-01	3.7554E-12	8.2793E-04	-1.0021E-14
17.800	-3.7453E-03	3.1337E-12	2.5912E-01	3.1529E-12	8.2793E-04	-1.0319E-14
17.900	-3.7667E-03	3.2036E-12	2.5912E-01	2.5217E-12	8.2793E-04	-1.0734E-14
18.000	-3.7882E-03	3.2582E-12	2.5912E-01	1.9621E-12	8.2793E-04	-1.0851E-14
18.100	-3.8096E-03	3.3008E-12	2.5912E-01	1.5476E-12	8.2793E-04	-1.0630E-14
18.200	-3.8311E-03	3.3356E-12	2.5912E-01	1.3020E-12	8.2793E-04	-1.0946E-14
18.300	-3.8525E-03	3.3673E-12	2.5912E-01	1.1951E-12	8.2793E-04	-1.0737E-14
18.400	-3.8740E-03	3.3988E-12	2.5912E-01	1.1616E-12	8.2793E-04	-1.0873E-14
18.500	-3.8955E-03	3.4314E-12	2.5912E-01	1.1331E-12	8.2793E-04	-1.0820E-14
18.600	-3.9169E-03	3.4644E-12	2.5912E-01	1.0735E-12	8.2793E-04	-1.1036E-14
18.700	-3.9384E-03	3.4967E-12	2.5912E-01	1.0012E-12	8.2793E-04	-1.0890E-14
18.800	-3.9598E-03	3.5281E-12	2.5912E-01	9.8977E-13	8.2793E-04	-1.1099E-14
18.900	-3.9813E-03	3.5607E-12	2.5912E-01	1.1427E-12	8.2793E-04	-1.1474E-14
19.000	-4.0027E-03	3.5995E-12	2.5912E-01	1.5520E-12	8.2793E-04	-1.1229E-14
19.100	-4.0242E-03	3.6512E-12	2.5912E-01	2.2539E-12	8.2793E-04	-1.1504E-14
19.200	-4.0456E-03	3.7230E-12	2.5912E-01	3.2011E-12	8.2793E-04	-1.1828E-14
19.300	-4.0671E-03	3.8199E-12	2.5912E-01	4.2628E-12	8.2793E-04	-1.2004E-14
19.400	-4.0885E-03	3.9431E-12	2.5912E-01	5.2538E-12	8.2793E-04	-1.2459E-14
19.500	-4.1100E-03	4.0886E-12	2.5912E-01	5.9812E-12	8.2793E-04	-1.2989E-14
19.600	-4.1314E-03	4.2477E-12	2.5912E-01	6.2903E-12	8.2793E-04	-1.3523E-14
19.700	-4.1529E-03	4.4084E-12	2.5912E-01	6.0923E-12	8.2793E-04	-1.4017E-14
19.800	-4.1743E-03	4.5574E-12	2.5912E-01	5.3651E-12	8.2793E-04	-1.4483E-14
19.900	-4.1958E-03	4.6813E-12	2.5912E-01	4.1342E-12	8.2793E-04	-1.4791E-14
20.000	-4.2173E-03	4.7678E-12	2.5912E-01	2.4489E-12	8.2793E-04	-1.4903E-14
20.100	-4.2387E-03	4.8060E-12	2.5912E-01	3.7117E-13	8.2793E-04	-1.4769E-14

Contrails

RUN NO 1

PAGE NO 14

TIME	P- 1	P- 2	P- 3	P- 4	P- 5
16.500	-2.22347E-06	-1.31860E-07	1.44423E-03	4.12628E-13	-1.20946E-06
16.600	-2.00581E-06	-2.38050E-07	6.86497E-04	1.07802E-12	-9.57156E-07
16.700	-1.66528E-06	-3.29563E-07	-1.87121E-04	1.27037E-12	-3.90946E-07
16.800	-1.21603E-06	-3.99916E-07	-1.11809E-03	9.18591E-13	3.43302E-07
16.900	-6.85435E-07	-4.44220E-07	-2.02618E-03	9.93951E-14	1.03929E-06
17.000	-1.13087E-07	-4.59551E-07	-2.83597E-03	-1.04727E-12	1.50380E-06
17.100	4.53323E-07	-4.45078E-07	-3.50156E-03	-2.17564E-12	1.62547E-06
17.200	9.64364E-07	-4.01964E-07	-4.02081E-03	-3.00699E-12	1.41421E-06
17.300	1.37592E-06	-3.33103E-07	-4.43386E-03	-3.35027E-12	9.97020E-07
17.400	1.65510E-06	-2.42802E-07	-4.80669E-03	-3.16576E-12	5.71939E-07
17.500	1.78350E-06	-1.36458E-07	-5.20540E-03	-2.57600E-12	3.36479E-07
17.600	1.75725E-06	-2.02882E-08	-5.67073E-03	-1.87474E-12	4.16382E-07
17.700	1.58425E-06	9.88912E-08	-6.20173E-03	-1.34799E-12	8.20182E-07
17.800	1.27980E-06	2.13898E-07	-6.75465E-03	-1.16387E-12	1.43588E-06
17.900	8.62427E-07	3.17468E-07	-7.25726E-03	-1.32146E-12	2.07092E-06
18.000	3.51244E-07	4.02654E-07	-7.63369E-03	-1.69506E-12	2.52100E-06
18.100	-2.34445E-07	4.63318E-07	-7.83064E-03	-2.04750E-12	2.64322E-06
18.200	-8.73522E-07	4.94693E-07	-7.83573E-03	-2.07598E-12	2.40707E-06
18.300	-1.54054E-06	4.93912E-07	-7.68144E-03	-1.61303E-12	1.90520E-06
18.400	-2.20389E-06	4.60392E-07	-7.43303E-03	-6.64527E-13	1.32003E-06
18.500	-2.82589E-06	3.95991E-07	-7.16508E-03	5.94257E-13	8.58237E-07
18.600	-3.36563E-06	3.04892E-07	-6.93485E-03	1.83204E-12	6.76612E-07
18.700	-3.78402E-06	1.93216E-07	-6.76209E-03	2.72067E-12	8.25957E-07
18.800	-4.05002E-06	6.84497E-08	-6.62260E-03	3.01035E-12	1.23306E-06
18.900	-4.14613E-06	-6.12121E-08	-6.45767E-03	2.65461E-12	1.72721E-06
19.000	-4.07165E-06	-1.87501E-07	-6.19622E-03	1.81046E-12	2.10174E-06
19.100	-3.84260E-06	-3.02600E-07	-5.78147E-03	7.42886E-13	2.18844E-06
19.200	-3.48845E-06	-3.99532E-07	-5.19269E-03	-2.37366E-13	1.91819E-06
19.300	-3.04652E-06	-4.72423E-07	-4.45415E-03	-9.23277E-13	1.34603E-06
19.400	-2.55586E-06	-5.16699E-07	-3.62812E-03	-1.13392E-12	6.31694E-07
19.500	-2.05226E-06	-5.29263E-07	-2.79435E-03	-9.40655E-13	-1.72904E-08
19.600	-1.56552E-06	-5.08699E-07	-2.02346E-03	-5.67059E-13	-4.19670E-07
19.700	-1.11944E-06	-4.55484E-07	-1.35358E-03	-3.46613E-13	-4.84974E-07
19.800	-7.33745E-07	-3.72159E-07	-7.79389E-04	-4.77028E-13	-2.45412E-07
19.900	-4.26560E-07	-2.63394E-07	-2.55362E-04	-1.04847E-12	1.56272E-07
20.000	-2.15985E-07	-1.35842E-07	2.84629E-04	-1.92072E-12	5.18602E-07
20.100	-1.19653E-07	2.22593E-09	9.01733E-04	-2.89607E-12	6.54200E-07

Contrails

RUN NO 1

PAGE NO 15

TIME	P- 6	P- 7	P- 8	P- 9	P-10
16.500	8.65233E-11	4.29826E-05	3.03867E-06	1.54125E-03	3.81054E-05
16.600	1.66789E-10	4.13183E-05	3.03554E-06	2.60466E-02	3.18319E-05
16.700	2.37208E-10	3.71350E-05	2.80724E-06	3.60692E-02	2.35963E-05
16.800	2.93136E-10	3.05584E-05	2.33191E-06	3.80840E-02	1.37891E-05
16.900	3.30793E-10	2.19789E-05	1.63027E-06	4.13885E-02	3.01832E-06
17.000	3.47515E-10	1.20404E-05	7.67927E-07	5.46739E-02	-7.91613E-06
17.100	3.41946E-10	1.57082E-06	-1.56020E-07	8.28174E-02	-1.81031E-05
17.200	3.14151E-10	-8.52920E-06	-1.03067E-06	1.25047E-01	-2.66404E-05
17.300	2.65643E-10	-1.74142E-05	-1.75844E-06	1.75136E-01	-3.27644E-05
17.400	1.99306E-10	-2.44029E-05	-2.27548E-06	2.23560E-01	-3.59571E-05
17.500	1.19237E-10	-2.90420E-05	-2.56110E-06	2.60836E-01	-3.60006E-05
17.600	3.04814E-11	-3.11150E-05	-2.63358E-06	2.80854E-01	-3.29704E-05
17.700	-6.12872E-11	-3.06011E-05	-2.53472E-06	2.82996E-01	-2.71751E-05
17.800	-1.50142E-10	-2.76074E-05	-2.30922E-06	2.72299E-01	-1.90658E-05
17.900	-2.30293E-10	-2.23045E-05	-1.98659E-06	2.57587E-01	-9.14747E-06
18.000	-2.96468E-10	-1.48895E-05	-1.57238E-06	2.48258E-01	2.07991E-06
18.100	-3.44258E-10	-5.58852E-06	-1.05157E-06	2.50877E-01	1.41386E-05
18.200	-3.70400E-10	5.30577E-06	-4.02702E-07	2.66791E-01	2.65509E-05
18.300	-3.72993E-10	1.73832E-05	3.82831E-07	2.91630E-01	3.87992E-05
18.400	-3.51618E-10	3.00790E-05	1.28418E-06	3.16866E-01	5.02951E-05
18.500	-3.07383E-10	4.26756E-05	2.24367E-06	3.32871E-01	6.03824E-05
18.600	-2.42864E-10	5.43549E-05	3.17242E-06	3.32376E-01	6.83869E-05
18.700	-1.61964E-10	6.42946E-05	3.96780E-06	3.13091E-01	7.37055E-05
18.800	-6.96910E-11	7.17872E-05	4.53727E-06	2.78548E-01	7.59136E-05
18.900	2.81480E-11	7.63483E-05	4.82109E-06	2.36858E-01	7.48576E-05
19.000	1.25304E-10	7.77855E-05	4.80611E-06	1.97838E-01	7.07041E-05
19.100	2.15485E-10	7.62093E-05	4.52643E-06	1.69540E-01	6.39272E-05
19.200	2.92773E-10	7.19844E-05	4.05072E-06	1.55412E-01	5.52364E-05
19.300	3.52019E-10	6.56414E-05	3.46099E-06	1.53131E-01	4.54626E-05
19.400	3.89196E-10	5.77749E-05	2.83001E-06	1.55504E-01	3.54354E-05
19.500	4.01681E-10	4.89607E-05	2.20512E-06	1.53130E-01	2.58836E-05
19.600	3.88438E-10	3.97129E-05	1.60360E-06	1.37847E-01	1.73802E-05
19.700	3.50094E-10	3.04844E-05	1.02043E-06	1.05743E-01	1.03406E-05
19.800	2.88905E-10	2.17008E-05	4.44801E-07	5.86458E-02	5.05825E-06
19.900	2.08615E-10	1.38009E-05	-1.21611E-07	3.54740E-03	1.75545E-06
20.000	1.14219E-10	7.25783E-06	-6.51900E-07	-4.98133E-02	6.18969E-07
20.100	1.16497E-11	2.56255E-06	-1.09230E-06	-9.23549E-02	1.80110E-06

Contrails

RUN NO 1

PAGE NO 16

TIME	P-11	P-12	P-13	P-14	P-15
16.500	-5.17698E-07	1.54125E-03	-1.33439E-04	-1.33439E-04	
16.600	-3.42190E-07	2.60465E-02	-1.01738E-04	-1.01738E-04	
16.700	-1.84152E-07	3.60691E-02	-3.75973E-05	-3.75973E-05	
16.800	-7.73249E-08	3.80839E-02	4.38700E-05	4.38701E-05	
16.900	-3.54791E-08	4.13884E-02	1.21309E-04	1.21309E-04	
17.000	-4.92221E-08	5.46739E-02	1.74717E-04	1.74717E-04	
17.100	-9.12323E-08	8.28174E-02	1.92547E-04	1.92547E-04	
17.200	-1.27936E-07	1.25047E-01	1.75771E-04	1.75770E-04	
17.300	-1.33299E-07	1.75136E-01	1.37458E-04	1.37458E-04	
17.400	-9.96551E-08	2.23560E-01	9.80137E-05	9.80136E-05	
17.500	-4.16118E-08	2.60836E-01	7.77920E-05	7.77920E-05	
17.600	8.46406E-09	2.80854E-01	8.97394E-05	8.97395E-05	
17.700	1.18131E-08	2.82996E-01	1.34703E-04	1.34703E-04	
17.800	-6.25625E-08	2.72299E-01	2.01089E-04	2.01089E-04	
17.900	-2.26045E-07	2.57587E-01	2.68987E-04	2.68987E-04	
18.000	-4.65120E-07	2.48258E-01	3.17280E-04	3.17280E-04	
18.100	-7.44631E-07	2.50877E-01	3.31196E-04	3.31196E-04	
18.200	-1.01851E-06	2.66791E-01	3.07573E-04	3.07573E-04	
18.300	-1.24419E-06	2.91630E-01	2.55970E-04	2.55970E-04	
18.400	-1.39572E-06	3.16866E-01	1.95222E-04	1.95222E-04	
18.500	-1.47095E-06	3.32871E-01	1.46674E-04	1.46674E-04	
18.600	-1.49032E-06	3.32376E-01	1.26522E-04	1.26522E-04	
18.700	-1.48792E-06	3.13091E-01	1.40027E-04	1.40027E-04	
18.800	-1.49799E-06	2.78548E-01	1.79644E-04	1.79644E-04	
18.900	-1.54182E-06	2.36858E-01	2.27771E-04	2.27771E-04	
19.000	-1.61984E-06	1.97838E-01	2.63092E-04	2.63092E-04	
19.100	-1.71168E-06	1.69540E-01	2.68270E-04	2.68270E-04	
19.200	-1.78418E-06	1.55412E-01	2.36201E-04	2.36201E-04	
19.300	-1.80434E-06	1.53131E-01	1.72606E-04	1.72606E-04	
19.400	-1.75267E-06	1.55504E-01	9.40234E-05	9.40234E-05	
19.500	-1.63180E-06	1.53130E-01	2.19241E-05	2.19241E-05	
19.600	-1.46734E-06	1.37847E-01	-2.49286E-05	-2.49285E-05	
19.700	-1.30047E-06	1.05743E-01	-3.71440E-05	-3.71439E-05	
19.800	-1.17484E-06	5.86457E-02	-1.79979E-05	-1.79978E-05	
19.900	-1.12233E-06	3.54735E-03	1.78214E-05	1.78215E-05	
20.000	-1.15276E-06	-4.98133E-02	4.95616E-05	4.95616E-05	
20.100	-1.25102E-06	-9.23549E-02	5.79262E-05	5.79261E-05	

TABLE 20
LISTINGS OF COMPUTER RUNS FOR IMPULSIVE SPIN-UP RESPONSE

RUN NO 2 PAGE NO 1
PANDORA - LVV420 15 AUG 1963
RESPONSE OF TITAN III MODEL TO IMPULSIVE SPIN-UP

TIME SEC	VX IN/SEC	VY IN/SEC	VZ IN/SEC	OMEGAX RAD/SEC	OMEGAY RAD/SEC	OMEGAZ RAD/SEC
0.	0.	0.	0.	4.9998E-01	-0.	-0.
0.050	0.	0.	0.	4.9991E-01	-3.3578E-06	-8.1048E-09
0.100	0.	0.	0.	4.9975E-01	-1.0985E-05	-7.1804E-08
0.150	0.	0.	0.	4.9956E-01	-1.7627E-05	-2.6161E-07
0.200	0.	0.	0.	4.9939E-01	-1.9223E-05	-5.7779E-07
0.250	0.	0.	0.	4.9926E-01	-1.5996E-05	-8.5068E-07
0.300	0.	0.	0.	4.9910E-01	-1.2222E-05	-8.2816E-07
0.350	0.	0.	0.	4.9885E-01	-1.2890E-05	-4.6853E-07
0.400	0.	0.	0.	4.9849E-01	-1.9839E-05	-1.4899E-07
0.450	0.	0.	0.	4.9806E-01	-3.0339E-05	-4.6229E-07
0.500	0.	0.	0.	4.9764E-01	-3.9159E-05	-1.6566E-06
0.550	0.	0.	0.	4.9728E-01	-4.2536E-05	-3.2294E-06
0.600	0.	0.	0.	4.9697E-01	-4.0981E-05	-4.1860E-06
0.650	0.	0.	0.	4.9668E-01	-3.8801E-05	-3.8976E-06
0.700	0.	0.	0.	4.9633E-01	-4.0735E-05	-2.8275E-06
0.750	0.	0.	0.	4.9591E-01	-4.8286E-05	-2.3553E-06
0.800	0.	0.	0.	4.9547E-01	-5.8545E-05	-3.6727E-06
0.850	0.	0.	0.	4.9509E-01	-6.6375E-05	-6.6482E-06
0.900	0.	0.	0.	4.9481E-01	-6.8275E-05	-9.7356E-06
0.950	0.	0.	0.	4.9462E-01	-6.4992E-05	-1.1163E-05
1.000	0.	0.	0.	4.9448E-01	-6.0890E-05	-1.0461E-05
1.050	0.	0.	0.	4.9432E-01	-6.0584E-05	-8.9781E-06
1.100	0.	0.	0.	4.9412E-01	-6.5406E-05	-8.8312E-06
1.150	0.	0.	0.	4.9395E-01	-7.2378E-05	-1.1121E-05
1.200	0.	0.	0.	4.9385E-01	-7.6468E-05	-1.4944E-05
1.250	0.	0.	0.	4.9387E-01	-7.4415E-05	-1.8099E-05
1.300	0.	0.	0.	4.9400E-01	-6.7214E-05	-1.8892E-05
1.350	0.	0.	0.	4.9418E-01	-5.9361E-05	-1.7517E-05
1.400	0.	0.	0.	4.9435E-01	-5.5440E-05	-1.5829E-05
1.450	0.	0.	0.	4.9449E-01	-5.6649E-05	-1.5745E-05
1.500	0.	0.	0.	4.9463E-01	-5.9920E-05	-1.7679E-05
1.550	0.	0.	0.	4.9485E-01	-6.0300E-05	-2.0311E-05
1.600	0.	0.	0.	4.9517E-01	-5.4797E-05	-2.1798E-05
1.650	0.	0.	0.	4.9558E-01	-4.4722E-05	-2.1298E-05
1.700	0.	0.	0.	4.9600E-01	-3.4736E-05	-1.9522E-05
1.750	0.	0.	0.	4.9637E-01	-2.9325E-05	-1.7959E-05
1.800	0.	0.	0.	4.9669E-01	-2.9415E-05	-1.7594E-05
1.850	0.	0.	0.	4.9697E-01	-3.1737E-05	-1.8236E-05
1.900	0.	0.	0.	4.9730E-01	-3.1420E-05	-1.8900E-05
1.950	0.	0.	0.	4.9769E-01	-2.5831E-05	-1.8765E-05
2.000	0.	0.	0.	4.9811E-01	-1.6658E-05	-1.7780E-05
2.050	0.	0.	0.	4.9851E-01	-8.6468E-06	-1.6525E-05
2.100	0.	0.	0.	4.9881E-01	-5.9749E-06	-1.5590E-05
2.150	0.	0.	0.	4.9901E-01	-9.0804E-06	-1.5133E-05
2.200	0.	0.	0.	4.9915E-01	-1.4400E-05	-1.4911E-05
2.250	0.	0.	0.	4.9931E-01	-1.7197E-05	-1.4631E-05
2.300	0.	0.	0.	4.9949E-01	-1.5271E-05	-1.4191E-05
2.350	0.	0.	0.	4.9967E-01	-1.0646E-05	-1.3662E-05
2.400	0.	0.	0.	4.9978E-01	-7.9700E-06	-1.3147E-05
2.450	0.	0.	0.	4.9978E-01	-1.0880E-05	-1.2711E-05
2.500	0.	0.	0.	4.9967E-01	-1.9190E-05	-1.2421E-05
2.550	0.	0.	0.	4.9950E-01	-2.9056E-05	-1.2333E-05
2.600	0.	0.	0.	4.9934E-01	-3.5948E-05	-1.2385E-05
2.650	0.	0.	0.	4.9920E-01	-3.8110E-05	-1.2340E-05
2.700	0.	0.	0.	4.9906E-01	-3.7805E-05	-1.1954E-05

Contrails

RUN NO 2

PAGE NO 2

TIME	P- 1	P- 2	P- 3	P- 4	P- 5
0.	0.	0.	0.	0.	0.
0.050	-4.87135E-03	3.88413E-03	2.81334E-06	3.99347E-07	-1.01574E-08
0.100	-1.87107E-02	1.23698E-02	5.71208E-05	2.64692E-06	-7.49454E-08
0.150	-3.98232E-02	1.87109E-02	3.22242E-04	6.85814E-06	-2.29304E-07
0.200	-6.67852E-02	1.78319E-02	1.08035E-03	1.10883E-05	-4.85657E-07
0.250	-9.93202E-02	1.02756E-02	2.65041E-03	1.25778E-05	-8.49351E-07
0.300	-1.38159E-01	1.73206E-03	5.26648E-03	9.63089E-06	-1.34024E-06
0.350	-1.84011E-01	-1.44930E-03	9.01462E-03	2.69247E-06	-2.00317E-06
0.400	-2.36476E-01	2.77606E-03	1.38760E-02	-6.19165E-06	-2.89865E-06
0.450	-2.93774E-01	1.05858E-02	1.98389E-02	-1.51029E-05	-4.08092E-06
0.500	-3.53512E-01	1.53227E-02	2.69886E-02	-2.38299E-05	-5.57999E-06
0.550	-4.13882E-01	1.27136E-02	3.55017E-02	-3.40900E-05	-7.40100E-06
0.600	-4.74339E-01	4.18175E-03	4.55490E-02	-4.82357E-05	-9.54011E-06
0.650	-5.35243E-01	-4.31598E-03	5.71840E-02	-6.74489E-05	-1.20030E-05
0.700	-5.96768E-01	-6.97864E-03	7.03036E-02	-9.08089E-05	-1.48101E-05
0.750	-6.57963E-01	-2.68424E-03	8.47123E-02	-1.15941E-04	-1.79838E-05
0.800	-7.16724E-01	4.18222E-03	1.00237E-01	-1.40743E-04	-2.15266E-05
0.850	-7.70712E-01	7.20740E-03	1.16803E-01	-1.64854E-04	-2.54084E-05
0.900	-8.18486E-01	2.97904E-03	1.34410E-01	-1.89758E-04	-2.95715E-05
0.950	-8.59963E-01	-6.27371E-03	1.53029E-01	-2.17442E-04	-3.39502E-05
1.000	-8.95853E-01	-1.44656E-02	1.72508E-01	-2.48669E-04	-3.84903E-05
1.050	-9.26536E-01	-1.64289E-02	1.92558E-01	-2.82170E-04	-4.31528E-05
1.100	-9.51291E-01	-1.19215E-02	2.12834E-01	-3.15388E-04	-4.79014E-05
1.150	-9.68487E-01	-5.74910E-03	2.33051E-01	-3.46185E-04	-5.26847E-05
1.200	-9.76601E-01	-3.94855E-03	2.53043E-01	-3.74200E-04	-5.74292E-05
1.250	-9.75232E-01	-9.04947E-03	2.72718E-01	-4.00835E-04	-6.20491E-05
1.300	-9.65322E-01	-1.81214E-02	2.91960E-01	-4.27884E-04	-6.64682E-05
1.350	-9.48410E-01	-2.50992E-02	3.10543E-01	-4.55867E-04	-7.06361E-05
1.400	-9.25515E-01	-2.55270E-02	3.28141E-01	-4.83363E-04	-7.45271E-05
1.450	-8.96542E-01	-1.99937E-02	3.44424E-01	-5.07828E-04	-7.81250E-05
1.500	-8.60673E-01	-1.35979E-02	3.59159E-01	-5.27293E-04	-8.14037E-05
1.550	-8.17431E-01	-1.19024E-02	3.72254E-01	-5.41620E-04	-8.43219E-05
1.600	-7.67543E-01	-1.65759E-02	3.83692E-01	-5.52380E-04	-8.68341E-05
1.650	-7.12924E-01	-2.41223E-02	3.93428E-01	-5.61445E-04	-8.89090E-05
1.700	-6.55777E-01	-2.86533E-02	4.01323E-01	-5.69397E-04	-9.05407E-05
1.750	-5.97534E-01	-2.64939E-02	4.07171E-01	-5.74974E-04	-9.17429E-05
1.800	-5.38452E-01	-1.90102E-02	4.10794E-01	-5.75965E-04	-9.25296E-05
1.850	-4.78192E-01	-1.14765E-02	4.12143E-01	-5.70886E-04	-9.28986E-05
1.900	-4.16879E-01	-8.91397E-03	4.11305E-01	-5.60122E-04	-9.28292E-05
1.950	-3.55806E-01	-1.21833E-02	4.08433E-01	-5.45688E-04	-9.22968E-05
2.000	-2.97192E-01	-1.73716E-02	4.03634E-01	-5.29781E-04	-9.12922E-05
2.050	-2.43185E-01	-1.89112E-02	3.96926E-01	-5.13246E-04	-8.98307E-05
2.100	-1.94902E-01	-1.39501E-02	3.88278E-01	-4.95125E-04	-8.79451E-05
2.150	-1.52241E-01	-4.55399E-03	3.77712E-01	-4.73628E-04	-8.56669E-05
2.200	-1.14615E-01	3.94830E-03	3.65381E-01	-4.47757E-04	-8.30136E-05
2.250	-8.20014E-02	7.13509E-03	3.51557E-01	-4.18352E-04	-7.99914E-05
2.300	-5.54613E-02	4.89522E-03	3.36546E-01	-3.87720E-04	-7.66121E-05
2.350	-3.67080E-02	1.42454E-03	3.20584E-01	-3.58171E-04	-7.29104E-05
2.400	-2.70697E-02	1.86556E-03	3.03806E-01	-3.30551E-04	-6.89492E-05
2.450	-2.66651E-02	8.25479E-03	2.86304E-01	-3.03913E-04	-6.48069E-05
2.500	-3.44454E-02	1.79443E-02	2.68222E-01	-2.76551E-04	-6.05571E-05
2.550	-4.90622E-02	2.56920E-02	2.49818E-01	-2.47602E-04	-5.62562E-05
2.600	-6.98680E-02	2.77408E-02	2.31434E-01	-2.17975E-04	-5.19465E-05
2.650	-9.72525E-02	2.46820E-02	2.13394E-01	-1.89889E-04	-4.76724E-05
2.700	-1.32054E-01	2.08928E-02	1.95918E-01	-1.65402E-04	-4.34933E-05

Contrails

RUN NO 2

PAGE NO 3

TIME	P- 6	P- 7	P- 8	P- 9	P-10
0.	0.	0.	0.	0.	0.
0.050	-1.62872E-06	4.65973E-02	1.85861E-01	-3.79963E-03	1.31057E-01
0.100	-5.21625E-06	2.05750E-01	6.03804E-01	-2.72022E-02	4.76613E-01
0.150	-7.97882E-06	5.18452E-01	9.50849E-01	-7.95831E-02	9.33867E-01
0.200	-7.78121E-06	1.01415E 00	9.86179E-01	-1.57755E-01	1.42145E 00
0.250	-4.77276E-06	1.68441E 00	7.10808E-01	-2.52649E-01	1.53771E 00
0.300	-1.25159E-06	2.48354E 00	3.65356E-01	-3.59966E-01	2.55501E 00
0.350	1.24796E-07	3.35559E 00	2.48339E-01	-4.86732E-01	3.35515E 00
0.400	-1.60760E-06	4.26759E 00	4.91582E-01	-6.48803E-01	4.35650E 00
0.450	-4.98524E-06	5.22417E 00	9.61036E-01	-8.61157E-01	5.48952E 00
0.500	-7.25677E-06	6.25279E 00	1.35707E 00	-1.12826E 00	6.63950E 00
0.550	-6.50478E-06	7.37098E 00	1.43879E 00	-1.44172E 00	7.72296E 00
0.600	-3.10914E-06	8.56028E 00	1.20406E 00	-1.78700E 00	8.73846E 00
0.650	5.68695E-07	9.76692E 00	8.90105E-01	-2.15415E 00	9.75295E 00
0.700	2.02289E-06	1.09286E 01	7.94296E-01	-2.54465E 00	1.08350E 01
0.750	5.35677E-07	1.20079E 01	1.04939E 00	-2.96916E 00	1.19875E 01
0.800	-2.28287E-06	1.30067E 01	1.52237E 00	-3.43808E 00	1.31317E 01
0.850	-3.75179E-06	1.39518E 01	1.91313E 00	-3.95189E 00	1.41555E 01
0.900	-2.19093E-06	1.48621E 01	1.97941E 00	-4.49874E 00	1.49874E 01
0.950	1.79311E-06	1.57223E 01	1.71889E 00	-5.06096E 00	1.56398E 01
1.000	5.78924E-06	1.64839E 01	1.37100E 00	-5.62581E 00	1.61871E 01
1.050	7.44645E-06	1.70916E 01	1.23634E 00	-6.19225E 00	1.66984E 01
1.100	6.27430E-06	1.75170E 01	1.44914E 00	-6.76871E 00	1.71757E 01
1.150	3.99515E-06	1.77735E 01	1.77443E 00	-7.36343E 00	1.75465E 01
1.200	3.18989E-06	1.79002E 01	2.20842E 00	-7.97463E 00	1.77156E 01
1.250	5.29382E-06	1.79296E 01	2.20730E 00	-8.58794E 00	1.76363E 01
1.300	9.48990E-06	1.78601E 01	1.87226E 00	-9.18305E 00	1.73444E 01
1.350	1.33427E-05	1.76574E 01	1.45010E 00	-9.74470E 00	1.69303E 01
1.400	1.46702E-05	1.72816E 01	1.24770E 00	-1.02697E 01	1.64712E 01
1.450	1.32031E-05	1.67205E 01	1.39971E 00	-1.07648E 01	1.59756E 01
1.500	1.07582E-05	1.60046E 01	1.76534E 00	-1.12368E 01	1.53835E 01
1.550	9.80633E-06	1.51899E 01	2.03384E 00	-1.16828E 01	1.46212E 01
1.600	1.15512E-05	1.43241E 01	1.96012E 00	-1.20876E 01	1.36676E 01
1.650	1.50008E-05	1.34194E 01	1.55247E 00	-1.24311E 01	1.25804E 01
1.700	1.77360E-05	1.24535E 01	1.06906E 00	-1.26993E 01	1.14622E 01
1.750	1.77709E-05	1.13982E 01	8.24107E-01	-1.28923E 01	1.03934E 01
1.800	1.50636E-05	1.02534E 01	9.49732E-01	-1.30211E 01	9.38355E 00
1.850	1.15210E-05	9.06029E 00	1.29452E 00	-1.30977E 01	8.37897E 00
1.900	9.50798E-06	7.88421E 00	1.53761E 00	-1.31244E 01	7.31902E 00
1.950	1.00221E-05	6.77855E 00	1.43317E 00	-1.30920E 01	6.19741E 00
2.000	1.19391E-05	5.75783E 00	9.99878E-01	-1.29867E 01	5.08051E 00
2.050	1.28993E-05	4.79991E 00	5.09981E-01	-1.28018E 01	4.06886E 00
2.100	1.11377E-05	3.87580E 00	2.84323E-01	-1.25452E 01	3.23212E 00
2.150	6.84164E-06	2.98427E 00	4.48210E-01	-1.22357E 01	2.56782E 00
2.200	1.99926E-06	2.16464E 00	8.34534E-01	-1.18920E 01	2.01527E 00
2.250	-1.13158E-06	1.47755E 00	1.10981E 00	-1.15219E 01	1.51297E 00
2.300	-1.74244E-06	9.68073E-01	1.02879E 00	-1.11202E 01	1.05455E 00
2.350	-1.06019E-06	6.38970E-01	6.23823E-01	-1.06764E 01	6.99735E-01
2.400	-1.36123E-06	4.54689E-01	1.83023E-01	-1.01872E 01	5.32516E-01
2.450	-4.18756E-06	3.73111E-01	3.20248E-02	-9.66346E 00	5.99341E-01
2.500	-9.14344E-06	3.80902E-01	2.84626E-01	-9.12595E 00	8.75290E-01
2.550	-1.41908E-05	5.05321E-01	7.53643E-01	-9.59397E 00	1.28393E 00
2.600	-1.72015E-05	7.93194E-01	1.09186E 00	-8.07446E 00	1.75483E 00
2.650	-1.75619E-05	1.27292E 00	1.05711E 00	-7.56054E 00	2.27379E 00
2.700	-1.65978E-05	1.92860E 00	6.99062E-01	-7.04043E 00	2.88728E 00

Contrails

RUN NO 2

PAGE NO 4

TIME	P-11	P-12	P-13	P-14	P-15
0.	0.	0.	0.	0.	
0.050	-4.21561E-01	4.83876E-03	5.68264E-07	-2.65181E-06	
0.100	-1.34930E 00	3.09139E-02	3.30913E-06	-1.92982E-05	
0.150	-2.06297E 00	7.48977E-02	6.44877E-06	-5.78663E-05	
0.200	-2.01495E 00	1.04556E-01	3.39836E-06	-1.19036E-04	
0.250	-1.25295E 00	7.68289E-02	-1.46414E-05	-2.00480E-04	
0.300	-3.78279E-01	-3.54101E-02	-5.46165E-05	-3.03196E-04	
0.350	-7.56408E-02	-2.28561E-01	-1.19215E-04	-4.34940E-04	
0.400	-5.82207E-01	-4.76699E-01	-2.07916E-04	-6.08046E-04	
0.450	-1.50754E 00	-7.56397E-01	-3.20596E-04	-8.33308E-04	
0.500	-2.14096E 00	-1.06849E 00	-4.60825E-04	-1.11462E-03	
0.550	-2.00433E 00	-1.43989E 00	-6.36177E-04	-1.44842E-03	
0.600	-1.21992E 00	-1.90424E 00	-8.55211E-04	-1.82827E-03	
0.650	-4.10394E-01	-2.47652E 00	-1.12325E-03	-2.25091E-03	
0.700	-2.12265E-01	-3.14137E 00	-1.44001E-03	-2.71895E-03	
0.750	-7.82984E-01	-3.86389E 00	-1.80077E-03	-3.23830E-03	
0.800	-1.68329E 00	-4.61453E 00	-2.19993E-03	-3.81213E-03	
0.850	-2.22246E 00	-5.38864E 00	-2.63433E-03	-4.43631E-03	
0.900	-1.99492E 00	-6.20566E 00	-3.10357E-03	-5.09964E-03	
0.950	-1.19118E 00	-7.08885E 00	-3.60733E-03	-5.78882E-03	
1.000	-4.44649E-01	-8.04161E 00	-4.14171E-03	-6.49429E-03	
1.050	-3.37191E-01	-9.03865E 00	-4.69756E-03	-7.21247E-03	
1.100	-9.49508E-01	-1.00389E 01	-5.26230E-03	-7.94287E-03	
1.150	-1.80361E 00	-1.10098E 01	-5.82384E-03	-8.68244E-03	
1.200	-2.23804E 00	-1.19449E 01	-6.37408E-03	-9.42168E-03	
1.250	-1.92123E 00	-1.28600E 01	-6.90930E-03	-1.01456E-02	
1.300	-1.10447E 00	-1.37727E 01	-7.42747E-03	-1.08390E-02	
1.350	-4.21524E-01	-1.46805E 01	-7.92473E-03	-1.14918E-02	
1.400	-3.94660E-01	-1.55545E 01	-8.39380E-03	-1.21007E-02	
1.450	-1.03215E 00	-1.63540E 01	-8.82561E-03	-1.26657E-02	
1.500	-1.82749E 00	-1.70507E 01	-9.21300E-03	-1.31850E-02	
1.550	-2.15661E 00	-1.76426E 01	-9.55352E-03	-1.36512E-02	
1.600	-1.76160E 00	-1.81493E 01	-9.84926E-03	-1.40526E-02	
1.650	-9.46044E-01	-1.85901E 01	-1.01037E-02	-1.43790E-02	
1.700	-3.34257E-01	-1.89646E 01	-1.03177E-02	-1.46257E-02	
1.750	-3.85378E-01	-1.92484E 01	-1.04883E-02	-1.47951E-02	
1.800	-1.04074E 00	-1.94096E 01	-1.06098E-02	-1.48926E-02	
1.850	-1.77539E 00	-1.94309E 01	-1.06779E-02	-1.49213E-02	
1.900	-2.00928E 00	-1.93222E 01	-1.06920E-02	-1.48791E-02	
1.950	-1.55609E 00	-1.91126E 01	-1.06555E-02	-1.47603E-02	
2.000	-7.62574E-01	-1.88290E 01	-1.05720E-02	-1.45612E-02	
2.050	-2.34473E-01	-1.84778E 01	-1.04427E-02	-1.42839E-02	
2.100	-3.65791E-01	-1.80435E 01	-1.02650E-02	-1.39372E-02	
2.150	-1.03739E 00	-1.75054E 01	-1.00344E-02	-1.35323E-02	
2.200	-1.71553E 00	-1.68591E 01	-9.74879E-03	-1.30773E-02	
2.250	-1.86926E 00	-1.61257E 01	-9.41087E-03	-1.25754E-02	
2.300	-1.38030E 00	-1.53421E 01	-9.02806E-03	-1.20266E-02	
2.350	-6.29045E-01	-1.45399E 01	-8.60923E-03	-1.14332E-02	
2.400	-1.94636E-01	-1.37286E 01	-8.16128E-03	-1.08031E-02	
2.450	-4.05525E-01	-1.28971E 01	-7.68796E-03	-1.01498E-02	
2.500	-1.08944E 00	-1.20305E 01	-7.19188E-03	-9.48786E-03	
2.550	-1.71298E 00	-1.11302E 01	-6.67792E-03	-8.82812E-03	
2.600	-1.79793E 00	-1.02206E 01	-6.15536E-03	-8.17555E-03	
2.650	-1.28925E 00	-9.33831E 00	-5.63688E-03	-7.53187E-03	
2.700	-5.91609E-01	-8.51090E 00	-5.13490E-03	-6.90030E-03	

Contrails

RUN NO 2

PAGE NO 5

TIME SEC	VX IN/SEC	VY IN/SEC	VZ IN/SEC	OMEGAX RAD/SEC	OMEGAY RAD/SEC	OMEGAZ RAD/SEC
2.750	0.	0.	0.	4.9885E-01	-3.9445E-05	-1.1282E-05
2.800	0.	0.	0.	4.9854E-01	-4.6077E-05	-1.0773E-05
2.850	0.	0.	0.	4.9815E-01	-5.6969E-05	-1.0945E-05
2.900	0.	0.	0.	4.9774E-01	-6.8133E-05	-1.1831E-05
2.950	0.	0.	0.	4.9736E-01	-7.5337E-05	-1.2767E-05
3.000	0.	0.	0.	4.9703E-01	-7.7261E-05	-1.2850E-05
3.050	0.	0.	0.	4.9672E-01	-7.6373E-05	-1.1787E-05
3.100	0.	0.	0.	4.9639E-01	-7.6892E-05	-1.0341E-05
3.150	0.	0.	0.	4.9599E-01	-8.1441E-05	-9.8313E-06
3.200	0.	0.	0.	4.9556E-01	-8.8973E-05	-1.0988E-05
3.250	0.	0.	0.	4.9516E-01	-9.5548E-05	-1.3167E-05
3.300	0.	0.	0.	4.9484E-01	-9.7314E-05	-1.4730E-05
3.350	0.	0.	0.	4.9460E-01	-9.3416E-05	-1.4397E-05
3.400	0.	0.	0.	4.9441E-01	-8.6582E-05	-1.2433E-05
3.450	0.	0.	0.	4.9423E-01	-8.0988E-05	-1.0553E-05
3.500	0.	0.	0.	4.9403E-01	-7.9042E-05	-1.0521E-05
3.550	0.	0.	0.	4.9384E-01	-7.9577E-05	-1.2617E-05
3.600	0.	0.	0.	4.9370E-01	-7.8801E-05	-1.5313E-05
3.650	0.	0.	0.	4.9366E-01	-7.3272E-05	-1.6524E-05
3.700	0.	0.	0.	4.9373E-01	-6.2599E-05	-1.5355E-05
3.750	0.	0.	0.	4.9386E-01	-4.9790E-05	-1.2856E-05
3.800	0.	0.	0.	4.9400E-01	-3.9014E-05	-1.1105E-05
3.850	0.	0.	0.	4.9412E-01	-3.2494E-05	-1.1453E-05
3.900	0.	0.	0.	4.9426E-01	-2.8925E-05	-1.3424E-05
3.950	0.	0.	0.	4.9445E-01	-2.4631E-05	-1.5201E-05
4.000	0.	0.	0.	4.9473E-01	-1.6529E-05	-1.5203E-05
4.050	0.	0.	0.	4.9509E-01	-4.6236E-06	-1.3355E-05
4.100	0.	0.	0.	4.9548E-01	7.9004E-06	-1.1004E-05
4.150	0.	0.	0.	4.9585E-01	1.7033E-05	-9.6817E-06
4.200	0.	0.	0.	4.9619E-01	2.0909E-05	-9.8490E-06
4.250	0.	0.	0.	4.9650E-01	2.1096E-05	-1.0682E-05
4.300	0.	0.	0.	4.9684E-01	2.1235E-05	-1.0938E-05
4.350	0.	0.	0.	4.9723E-01	2.4118E-05	-1.0026E-05
4.400	0.	0.	0.	4.9764E-01	2.9463E-05	-8.3625E-06
4.450	0.	0.	0.	4.9805E-01	3.4141E-05	-6.8362E-06
4.500	0.	0.	0.	4.9839E-01	3.4533E-05	-6.0016E-06
4.550	0.	0.	0.	4.9866E-01	2.9327E-05	-5.7317E-06
4.600	0.	0.	0.	4.9887E-01	2.0441E-05	-5.5155E-06
4.650	0.	0.	0.	4.9907E-01	1.1505E-05	-4.9845E-06
4.700	0.	0.	0.	4.9928E-01	5.0727E-06	-4.1561E-06
4.750	0.	0.	0.	4.9949E-01	7.4033E-07	-3.2676E-06
4.800	0.	0.	0.	4.9964E-01	-4.4106E-06	-2.4912E-06
4.850	0.	0.	0.	4.9971E-01	-1.3445E-05	-1.8396E-06
4.900	0.	0.	0.	4.9968E-01	-2.7130E-05	-1.2745E-06
4.950	0.	0.	0.	4.9960E-01	-4.3283E-05	-7.9762E-07
5.000	0.	0.	0.	4.9949E-01	-5.8363E-05	-3.9010E-07
5.050	0.	0.	0.	4.9938E-01	-7.0046E-05	7.8725E-08
5.100	0.	0.	0.	4.9925E-01	-7.8808E-05	7.7634E-07
5.150	0.	0.	0.	4.9908E-01	-8.7342E-05	1.6847E-06
5.200	0.	0.	0.	4.9883E-01	-9.8307E-05	2.4989E-06
5.250	0.	0.	0.	4.9851E-01	-1.1215E-04	2.8572E-06
5.300	0.	0.	0.	4.9815E-01	-1.2663E-04	2.7486E-06
5.350	0.	0.	0.	4.9780E-01	-1.3844E-04	2.6611E-06
5.400	0.	0.	0.	4.9746E-01	-1.4553E-04	3.2064E-06
5.450	0.	0.	0.	4.9714E-01	-1.4852E-04	4.4861E-06

Contrails

RUN NO 2

PAGE NO 6

TIME	P- 1	P- 2	P- 3	P- 4	P- 5
2.750	-1.74520E-01	2.10358E-02	1.79106E-01	-1.45033E-04	-3.94834E-05
2.800	-2.23658E-01	2.63919E-02	1.63007E-01	-1.27562E-04	-3.57147E-05
2.850	-2.77489E-01	3.38837E-02	1.47716E-01	-1.11120E-04	-3.22385E-05
2.900	-3.34018E-01	3.85093E-02	1.33418E-01	-9.47505E-05	-2.90754E-05
2.950	-3.92150E-01	3.72396E-02	1.20337E-01	-7.92205E-05	-2.62242E-05
3.000	-4.51836E-01	3.13255E-02	1.08645E-01	-6.64759E-05	-2.36796E-05
3.050	-5.13350E-01	2.52419E-02	9.83818E-02	-5.81649E-05	-2.14461E-05
3.100	-5.76282E-01	2.31469E-02	8.94674E-02	-5.43659E-05	-1.95362E-05
3.150	-6.39071E-01	2.56501E-02	8.17819E-02	-5.34916E-05	-1.79557E-05
3.200	-6.99450E-01	2.93999E-02	7.52596E-02	-5.34332E-05	-1.66888E-05
3.250	-7.55467E-01	2.97664E-02	6.99159E-02	-5.30605E-05	-1.56949E-05
3.300	-8.06281E-01	2.44798E-02	6.57925E-02	-5.29246E-05	-1.49536E-05
3.350	-8.52103E-01	1.53786E-02	6.28620E-02	-5.46354E-05	-1.43275E-05
3.400	-8.93362E-01	6.93916E-03	6.09719E-02	-5.94034E-05	-1.38858E-05
3.450	-9.29756E-01	2.78388E-03	5.98728E-02	-6.68710E-05	-1.35874E-05
3.500	-9.59959E-01	2.91983E-03	5.93095E-02	-7.51293E-05	-1.34206E-05
3.550	-9.82229E-01	3.84147E-03	5.91047E-02	-8.19056E-05	-1.33574E-05
3.600	-9.95424E-01	1.36749E-03	5.91719E-02	-8.60086E-05	-1.33521E-05
3.650	-9.99645E-01	-6.04392E-03	5.94480E-02	-8.79305E-05	-1.33551E-05
3.700	-9.95971E-01	-1.60888E-02	5.98032E-02	-8.91576E-05	-1.33293E-05
3.750	-9.85538E-01	-2.44215E-02	6.00017E-02	-9.07347E-05	-1.32561E-05
3.800	-9.68661E-01	-2.80119E-02	5.97457E-02	-9.21940E-05	-1.31269E-05
3.850	-9.44728E-01	-2.74179E-02	5.87700E-02	-9.16708E-05	-1.29248E-05
3.900	-9.12917E-01	-2.62274E-02	5.69147E-02	-8.71203E-05	-1.26123E-05
3.950	-8.73186E-01	-2.81575E-02	5.41199E-02	-7.76984E-05	-1.21345E-05
4.000	-8.26721E-01	-3.41114E-02	5.03498E-02	-6.42540E-05	-1.14339E-05
4.050	-7.75496E-01	-4.14837E-02	4.55086E-02	-4.85638E-05	-1.04684E-05
4.100	-7.21282E-01	-4.62098E-02	3.94177E-02	-3.19055E-05	-9.21562E-06
4.150	-6.64884E-01	-4.59161E-02	3.18737E-02	-1.40661E-05	-7.66386E-06
4.200	-6.06209E-01	-4.16989E-02	2.27422E-02	6.45761E-06	-5.79633E-06
4.250	-5.45078E-01	-3.71793E-02	1.20155E-02	3.12263E-05	-3.58315E-06
4.300	-4.82147E-01	-3.56231E-02	-2.10778E-04	6.05468E-05	-9.88472E-07
4.350	-4.19171E-01	-3.74040E-02	-1.38225E-02	9.30912E-05	2.01181E-06
4.400	-3.58405E-01	-3.97744E-02	-2.87641E-02	1.26736E-04	5.41491E-06
4.450	-3.01601E-01	-3.90747E-02	-4.50469E-02	1.59975E-04	9.18985E-06
4.500	-2.49383E-01	-3.36132E-02	-6.26830E-02	1.92827E-04	1.32906E-05
4.550	-2.01488E-01	-2.49647E-02	-8.15974E-02	2.26541E-04	1.76733E-05
4.600	-1.57665E-01	-1.67124E-02	-1.01590E-01	2.62350E-04	2.23044E-05
4.650	-1.18502E-01	-1.16657E-02	-1.22378E-01	3.00215E-04	2.71532E-05
4.700	-8.55134E-02	-9.74674E-03	-1.43688E-01	3.38554E-04	3.21774E-05
4.750	-6.04256E-02	-8.17336E-03	-1.65325E-01	3.75139E-04	3.73127E-05
4.800	-4.42003E-02	-3.74349E-03	-1.87169E-01	4.08481E-04	4.24773E-05
4.850	-3.65832E-02	4.60109E-03	-2.09098E-01	4.38648E-04	4.75890E-05
4.900	-3.65191E-02	1.49302E-02	-2.30915E-01	4.66875E-04	5.25825E-05
4.950	-4.31008E-02	2.38174E-02	-2.52325E-01	4.94308E-04	5.74147E-05
5.000	-5.62958E-02	2.89577E-02	-2.72990E-01	5.20819E-04	6.20554E-05
5.050	-7.68753E-02	3.08521E-02	-2.92627E-01	5.44841E-04	6.64712E-05
5.100	-1.05606E-01	3.22757E-02	-3.11058E-01	5.64322E-04	7.06159E-05
5.150	-1.42349E-01	3.59950E-02	-3.28192E-01	5.78072E-04	7.44364E-05
5.200	-1.85794E-01	4.25513E-02	-3.43945E-01	5.86482E-04	7.78878E-05
5.250	-2.34027E-01	4.98304E-02	-3.58168E-01	5.91057E-04	8.09465E-05
5.300	-2.85504E-01	5.47100E-02	-3.70644E-01	5.93145E-04	8.36104E-05
5.350	-3.39657E-01	5.54549E-02	-3.81150E-01	5.92841E-04	8.58851E-05
5.400	-3.96666E-01	5.29838E-02	-3.89546E-01	5.88913E-04	8.77668E-05
5.450	-4.56590E-01	5.00530E-02	-3.95814E-01	5.79792E-04	8.92356E-05

Contrails

RUN NO 2

PAGE NO 7

TIME	P- 6	P- 7	P- 8	P- 9	P-10
2.750	-1.65068E-05	2.70626E 00	3.23182E-01	-6.51024E 00	3.65834E 00
2.800	-1.86341E-05	3.54785E 00	2.57672E-01	-5.98050E 00	4.60876E 00
2.850	-2.24224E-05	4.42717E 00	6.00605E-01	-5.47163E 00	5.69262E 00
2.900	-2.58359E-05	5.36023E 00	1.14175E 00	-5.00158E 00	6.82112E 00
2.950	-2.69162E-05	6.38215E 00	1.52089E 00	-4.57511E 00	7.91922E 00
3.000	-2.52656E-05	7.50812E 00	1.50292E 00	-4.18289E 00	8.96996E 00
3.050	-2.23202E-05	8.70863E 00	1.15899E 00	-3.81125E 00	1.00128E 01
3.100	-2.02172E-05	9.91835E 00	8.13333E-01	-3.45496E 00	1.10982E 01
3.150	-2.01416E-05	1.10723E 01	7.94600E-01	-3.12320E 00	1.22341E 01
3.200	-2.14255E-05	1.21418E 01	1.18166E 00	-2.83406E 00	1.33666E 01
3.250	-2.20845E-05	1.31430E 01	1.73982E 00	-2.60150E 00	1.44083E 01
3.300	-2.03617E-05	1.41111E 01	2.09821E 00	-2.42488E 00	1.52933E 01
3.350	-1.60851E-05	1.50604E 01	2.03378E 00	-2.28889E 00	1.60150E 01
3.400	-1.07993E-05	1.59608E 01	1.64352E 00	-2.17415E 00	1.66194E 01
3.450	-6.58408E-06	1.67491E 01	1.27139E 00	-2.07032E 00	1.71583E 01
3.500	-4.48081E-06	1.73679E 01	1.24405E 00	-1.98157E 00	1.76410E 01
3.550	-3.73670E-06	1.78004E 01	1.61806E 00	-1.92035E 00	1.80207E 01
3.600	-2.43693E-06	1.80763E 01	2.13370E 00	-1.89415E 00	1.82260E 01
3.650	9.76846E-07	1.82437E 01	2.41276E 00	-1.89548E 00	1.82125E 01
3.700	6.47627E-06	1.83274E 01	2.24936E 00	-1.90309E 00	1.79949E 01
3.750	1.24443E-05	1.83073E 01	1.77000E 00	-1.89358E 00	1.76344E 01
3.800	1.68891E-05	1.81332E 01	1.33808E 00	-1.85469E 00	1.71931E 01
3.850	1.89308E-05	1.77640E 01	1.27491E 00	-1.79021E 00	1.66894E 01
3.900	1.94184E-05	1.72028E 01	1.61139E 00	-1.71273E 00	1.60905E 01
3.950	2.02163E-05	1.64989E 01	2.06257E 00	-1.62983E 00	1.53454E 01
4.000	2.27233E-05	1.57167E 01	2.24626E 00	-1.53447E 00	1.44331E 01
4.050	2.67681E-05	1.48935E 01	1.97840E 00	-1.40712E 00	1.33882E 01
4.100	3.07238E-05	1.40198E 01	1.41716E 00	-1.22805E 00	1.22847E 01
4.150	3.27393E-05	1.30571E 01	9.43527E-01	-9.90456E-01	1.11907E 01
4.200	3.21327E-05	1.19787E 01	8.68830E-01	-7.04221E-01	1.01293E 01
4.250	2.98768E-05	1.08032E 01	1.19452E 00	-3.87305E-01	9.07530E 00
4.300	2.78186E-05	9.59355E 00	1.61024E 00	-5.12882E-02	7.98993E 00
4.350	2.72446E-05	8.42207E 00	1.73318E 00	3.07799E-01	6.86473E 00
4.400	2.78987E-05	7.32887E 00	1.40474E 00	7.06270E-01	5.74187E 00
4.450	2.81996E-05	6.30459E 00	8.15463E-01	1.15963E 00	4.69455E 00
4.500	2.64765E-05	5.31127E 00	3.60318E-01	1.66959E 00	3.78349E 00
4.550	2.22643E-05	4.32505E 00	3.35110E-01	2.22138E 00	3.02303E 00
4.600	1.66669E-05	3.36748E 00	7.08022E-01	2.79350E 00	2.38243E 00
4.650	1.15227E-05	2.50104E 00	1.14358E 00	3.37237E 00	1.82061E 00
4.700	8.02322E-06	1.79193E 00	1.26168E 00	3.96067E 00	1.32666E 00
4.750	5.85035E-06	1.26867E 00	9.32295E-01	4.57269E 00	9.34994E-01
4.800	3.48302E-06	9.08238E-01	3.77734E-01	5.22026E 00	7.03701E-01
4.850	-5.75381E-07	6.60621E-01	2.50662E-03	5.90014E 00	6.73531E-01
4.900	-6.60012E-06	4.92655E-01	8.12748E-02	6.59256E 00	8.39159E-01
4.950	-1.33945E-05	4.17326E-01	5.45976E-01	7.27222E 00	1.15452E 00
5.000	-1.91657E-05	4.85690E-01	1.03739E 00	7.92321E 00	1.56736E 00
5.050	-2.28451E-05	7.47514E-01	1.18220E 00	8.54639E 00	2.05606E 00
5.100	-2.48378E-05	1.21101E 00	8.81886E-01	9.15360E 00	2.64033E 00
5.150	-2.66381E-05	1.83283E 00	3.89615E-01	9.75314E 00	3.35852E 00
5.200	-2.96194E-05	2.54628E 00	1.14942E-01	1.03380E 01	4.22947E 00
5.250	-3.39349E-05	3.30599E 00	3.06644E-01	1.08861E 01	5.22876E 00
5.300	-3.83680E-05	4.11478E 00	8.59015E-01	1.13721E 01	6.29729E 00
5.350	-4.12372E-05	5.01187E 00	1.39207E 00	1.17826E 01	7.37513E 00
5.400	-4.16492E-05	6.03167E 00	1.54434E 00	1.21226E 01	8.43440E 00
5.450	-4.01415E-05	7.16520E 00	1.25199E 00	1.24077E 01	9.48626E 00

Contrails

RUN NO 2

PAGE NO 8

TIME	P-11	P-12	P-13	P-14	P-15
2.750	-2.50889E-01	-7.74337E 00	-4.65802E-03	-6.28875E-03	
2.800	-5.31230E-01	-7.02101E 00	-4.20985E-03	-5.70894E-03	
2.850	-1.21528E 00	-6.32700E 00	-3.79110E-03	-5.17200E-03	
2.900	-1.77847E 00	-5.66059E 00	-3.40301E-03	-4.68396E-03	
2.950	-1.79756E 00	-5.04179E 00	-3.04950E-03	-4.24448E-03	
3.000	-1.27515E 00	-4.49914E 00	-2.73622E-03	-3.84976E-03	
3.050	-6.31261E-01	-4.05019E 00	-2.46732E-03	-3.49720E-03	
3.100	-3.73358E-01	-3.68974E 00	-2.24248E-03	-3.18827E-03	
3.150	-7.04001E-01	-3.39481E 00	-2.05649E-03	-2.92734E-03	
3.200	-1.36924E 00	-3.14227E 00	-1.90189E-03	-2.71754E-03	
3.250	-1.86095E 00	-2.92518E 00	-1.77284E-03	-2.55689E-03	
3.300	-1.81184E 00	-2.75558E 00	-1.66729E-03	-2.43779E-03	
3.350	-1.27590E 00	-2.65159E 00	-1.58608E-03	-2.35014E-03	
3.400	-6.80082E-01	-2.61922E 00	-1.52976E-03	-2.28592E-03	
3.450	-4.89744E-01	-2.64301E 00	-1.49573E-03	-2.24153E-03	
3.500	-8.49757E-01	-2.69257E 00	-1.47788E-03	-2.21641E-03	
3.550	-1.47810E 00	-2.73989E 00	-1.46915E-03	-2.20899E-03	
3.600	-1.88966E 00	-2.77411E 00	-1.46490E-03	-2.21332E-03	
3.650	-1.77267E 00	-2.80241E 00	-1.46455E-03	-2.21895E-03	
3.700	-1.22563E 00	-2.83685E 00	-1.47013E-03	-2.21421E-03	
3.750	-6.74745E-01	-2.87765E 00	-1.48275E-03	-2.19029E-03	
3.800	-5.40771E-01	-2.90581E 00	-1.49960E-03	-2.14320E-03	
3.850	-9.15661E-01	-2.89092E 00	-1.51375E-03	-2.07201E-03	
3.900	-1.49756E 00	-2.80796E 00	-1.51674E-03	-1.97499E-03	
3.950	-1.82961E 00	-2.65014E 00	-1.50197E-03	-1.84665E-03	
4.000	-1.65382E 00	-2.42817E 00	-1.46638E-03	-1.67798E-03	
4.050	-1.10590E 00	-2.15678E 00	-1.40902E-03	-1.45984E-03	
4.100	-6.04257E-01	-1.83922E 00	-1.32786E-03	-1.18676E-03	
4.150	-5.23767E-01	-1.46171E 00	-1.21741E-03	-8.58429E-04	
4.200	-9.08857E-01	-1.00197E 00	-1.06906E-03	-4.77839E-04	
4.250	-1.44551E 00	-4.45178E-01	-8.74153E-04	-4.75020E-05	
4.300	-1.70900E 00	2.05116E-01	-6.27660E-04	4.33104E-04	
4.350	-1.49208E 00	9.29328E-01	-3.29678E-04	9.66980E-04	
4.400	-9.60143E-01	1.70546E 00	1.60864E-05	1.55633E-03	
4.450	-5.17627E-01	2.52336E 00	4.05640E-04	2.19913E-03	
4.500	-4.93423E-01	3.38872E 00	8.37182E-04	2.88817E-03	
4.550	-8.90249E-01	4.31394E 00	1.31082E-03	3.61328E-03	
4.600	-1.38892E 00	5.30323E 00	1.82577E-03	4.36510E-03	
4.650	-1.59933E 00	6.34345E 00	2.37733E-03	5.13741E-03	
4.700	-1.36098E 00	7.40780E 00	2.95608E-03	5.92655E-03	
4.750	-8.61534E-01	8.46934E 00	3.55006E-03	6.72826E-03	
4.800	-4.86329E-01	9.51386E 00	4.14857E-03	7.53482E-03	
4.850	-5.19326E-01	1.05424E 01	4.74474E-03	8.33457E-03	
4.900	-9.27705E-01	1.15619E 01	5.33522E-03	9.11440E-03	
4.950	-1.39336E 00	1.25711E 01	5.91736E-03	9.86334E-03	
5.000	-1.56215E 00	1.35535E 01	6.48626E-03	1.05745E-02	
5.050	-1.31564E 00	1.44815E 01	7.03398E-03	1.12444E-02	
5.100	-8.56789E-01	1.53303E 01	7.55171E-03	1.18695E-02	
5.150	-5.47970E-01	1.60885E 01	8.03311E-03	1.24441E-02	
5.200	-6.30413E-01	1.67601E 01	8.47625E-03	1.29594E-02	
5.250	-1.04217E 00	1.73542E 01	8.88273E-03	1.34069E-02	
5.300	-1.47176E 00	1.78724E 01	9.25430E-03	1.37805E-02	
5.350	-1.60132E 00	1.83034E 01	9.58980E-03	1.40788E-02	
5.400	-1.34949E 00	1.86275E 01	9.88445E-03	1.43035E-02	
5.450	-9.28203E-01	1.88297E 01	1.01320E-02	1.44565E-02	

Contrails

RUN NO 2

PAGE NO 9

TIME SEC	VX IN/SEC	VY IN/SEC	VZ IN/SEC	OMEGAX RAD/SEC	OMEGAY RAD/SEC	OMEGAZ RAD/SEC
5.500	0.	0.	0.	4.9681E-01	-1.5010E-04	5.8277E-06
5.550	0.	0.	0.	4.9644E-01	-1.5282E-04	6.2654E-06
5.600	0.	0.	0.	4.9604E-01	-1.5713E-04	5.4338E-06
5.650	0.	0.	0.	4.9564E-01	-1.6093E-04	4.0444E-06
5.700	0.	0.	0.	4.9529E-01	-1.6121E-04	3.3920E-06
5.750	0.	0.	0.	4.9500E-01	-1.5627E-04	4.2157E-06
5.800	0.	0.	0.	4.9476E-01	-1.4703E-04	5.9234E-06
5.850	0.	0.	0.	4.9455E-01	-1.3639E-04	6.9664E-06
5.900	0.	0.	0.	4.9434E-01	-1.2702E-04	6.1451E-06
5.950	0.	0.	0.	4.9414E-01	-1.1947E-04	3.7262E-06
6.000	0.	0.	0.	4.9398E-01	-1.1180E-04	1.3299E-06
6.050	0.	0.	0.	4.9389E-01	-1.0124E-04	6.0093E-07
6.100	0.	0.	0.	4.9388E-01	-8.6407E-05	1.7900E-06
6.150	0.	0.	0.	4.9395E-01	-6.8544E-05	3.5037E-06
6.200	0.	0.	0.	4.9405E-01	-5.0757E-05	3.8785E-06
6.250	0.	0.	0.	4.9417E-01	-3.5801E-05	2.1757E-06
6.300	0.	0.	0.	4.9429E-01	-2.4158E-05	-5.8836E-07
6.350	0.	0.	0.	4.9446E-01	-1.3856E-05	-2.5137E-06
6.400	0.	0.	0.	4.9469E-01	-2.1738E-06	-2.4130E-06
6.450	0.	0.	0.	4.9499E-01	1.2075E-05	-7.4753E-07
6.500	0.	0.	0.	4.9534E-01	2.7449E-05	8.6021E-07
6.550	0.	0.	0.	4.9571E-01	4.0827E-05	1.0425E-06
6.600	0.	0.	0.	4.9606E-01	4.9654E-05	-2.2450E-07
6.650	0.	0.	0.	4.9639E-01	5.3776E-05	-1.7422E-06
6.700	0.	0.	0.	4.9673E-01	5.5426E-05	-2.2014E-06
6.750	0.	0.	0.	4.9710E-01	5.7398E-05	-1.2490E-06
6.800	0.	0.	0.	4.9750E-01	6.0817E-05	3.7017E-07
6.850	0.	0.	0.	4.9790E-01	6.4235E-05	1.5838E-06
6.900	0.	0.	0.	4.9827E-01	6.4735E-05	1.8927E-06
6.950	0.	0.	0.	4.9859E-01	6.0182E-05	1.6335E-06
7.000	0.	0.	0.	4.9885E-01	5.0876E-05	1.5070E-06
7.050	0.	0.	0.	4.9907E-01	3.9348E-05	1.9213E-06
7.100	0.	0.	0.	4.9929E-01	2.8468E-05	2.7450E-06
7.150	0.	0.	0.	4.9950E-01	1.9335E-05	3.5780E-06
7.200	0.	0.	0.	4.9968E-01	1.0567E-05	4.1636E-06
7.250	0.	0.	0.	4.9980E-01	-4.8592E-07	4.5335E-06
7.300	0.	0.	0.	4.9984E-01	-1.5555E-05	4.8401E-06
7.350	0.	0.	0.	4.9981E-01	-3.3980E-05	5.1445E-06
7.400	0.	0.	0.	4.9972E-01	-5.3058E-05	5.4002E-06
7.450	0.	0.	0.	4.9962E-01	-6.9947E-05	5.5861E-06
7.500	0.	0.	0.	4.9951E-01	-8.3643E-05	5.7696E-06
7.550	0.	0.	0.	4.9936E-01	-9.5537E-05	5.9995E-06
7.600	0.	0.	0.	4.9916E-01	-1.0815E-04	6.1811E-06
7.650	0.	0.	0.	4.9889E-01	-1.2299E-04	6.1327E-06
7.700	0.	0.	0.	4.9856E-01	-1.3925E-04	5.8069E-06
7.750	0.	0.	0.	4.9821E-01	-1.5425E-04	5.4168E-06
7.800	0.	0.	0.	4.9786E-01	-1.6531E-04	5.2579E-06
7.850	0.	0.	0.	4.9753E-01	-1.7168E-04	5.3535E-06
7.900	0.	0.	0.	4.9720E-01	-1.7495E-04	5.3096E-06
7.950	0.	0.	0.	4.9684E-01	-1.7773E-04	4.6193E-06
8.000	0.	0.	0.	4.9646E-01	-1.8156E-04	3.1972E-06
8.050	0.	0.	0.	4.9606E-01	-1.8564E-04	1.6066E-06
8.100	0.	0.	0.	4.9568E-01	-1.8743E-04	6.5426E-07
8.150	0.	0.	0.	4.9535E-01	-1.8456E-04	6.3524E-07
8.200	0.	0.	0.	4.9508E-01	-1.7670E-04	9.3192E-07

Contrails

RUN NO 2

PAGE NO 10

TIME	P- 1	P- 2	P- 3	P- 4	P- 5
5.500	-5.18566E-01	4.90458E-02	-4.00017E-01	5.64863E-04	9.02627E-05
5.550	-5.80714E-01	5.01192E-02	-4.02222E-01	5.45070E-04	9.08267E-05
5.600	-6.40841E-01	5.11380E-02	-4.02430E-01	5.22366E-04	9.09262E-05
5.650	-6.97390E-01	4.94006E-02	-4.00590E-01	4.98442E-04	9.05771E-05
5.700	-7.49905E-01	4.37679E-02	-3.96666E-01	4.73702E-04	8.98004E-05
5.750	-7.98642E-01	3.55341E-02	-3.90718E-01	4.47269E-04	8.86073E-05
5.800	-8.43668E-01	2.73958E-02	-3.82920E-01	4.17999E-04	8.69971E-05
5.850	-8.84159E-01	2.13728E-02	-3.73512E-01	3.85710E-04	8.49681E-05
5.900	-9.18477E-01	1.73225E-02	-3.62712E-01	3.51674E-04	8.25344E-05
5.950	-9.44957E-01	1.31827E-02	-3.50666E-01	3.18006E-04	7.97355E-05
6.000	-9.62798E-01	6.70409E-03	-3.37468E-01	2.86396E-04	7.66314E-05
6.050	-9.72354E-01	-2.71609E-03	-3.23228E-01	2.57180E-04	7.32868E-05
6.100	-9.74605E-01	-1.35270E-02	-3.08147E-01	2.29428E-04	6.97570E-05
6.150	-9.70232E-01	-2.31982E-02	-2.92514E-01	2.01988E-04	6.60862E-05
6.200	-9.59035E-01	-3.01162E-02	-2.76649E-01	1.74662E-04	6.23169E-05
6.250	-9.40148E-01	-3.47096E-02	-2.60814E-01	1.48617E-04	5.85042E-05
6.300	-9.12885E-01	-3.89574E-02	-2.45174E-01	1.25710E-04	5.47198E-05
6.350	-8.77534E-01	-4.47120E-02	-2.29832E-01	1.07262E-04	5.10427E-05
6.400	-8.35474E-01	-5.21782E-02	-2.14899E-01	9.32027E-05	4.75413E-05
6.450	-7.88512E-01	-5.97249E-02	-2.00554E-01	8.22552E-05	4.42607E-05
6.500	-7.37971E-01	-6.51333E-02	-1.87032E-01	7.30030E-05	4.12230E-05
6.550	-6.84231E-01	-6.72687E-02	-1.74559E-01	6.50165E-05	3.84399E-05
6.600	-6.27083E-01	-6.68642E-02	-1.63272E-01	5.91768E-05	3.59268E-05
6.650	-5.66599E-01	-6.58408E-02	-1.53192E-01	5.69515E-05	3.37064E-05
6.700	-5.03814E-01	-6.57403E-02	-1.44276E-01	5.91831E-05	3.17998E-05
6.750	-4.40673E-01	-6.65209E-02	-1.36491E-01	6.53228E-05	3.02120E-05
6.800	-3.79271E-01	-6.66353E-02	-1.29863E-01	7.36955E-05	2.89238E-05
6.850	-3.20985E-01	-6.42889E-02	-1.24460E-01	8.25882E-05	2.78981E-05
6.900	-2.66160E-01	-5.88566E-02	-1.20319E-01	9.13253E-05	2.70953E-05
6.950	-2.14594E-01	-5.13540E-02	-1.17377E-01	1.00509E-04	2.64880E-05
7.000	-1.66413E-01	-4.36317E-02	-1.15468E-01	1.11246E-04	2.60631E-05
7.050	-1.22637E-01	-3.69641E-02	-1.14379E-01	1.23968E-04	2.58115E-05
7.100	-8.49770E-02	-3.11524E-02	-1.13931E-01	1.37758E-04	2.57135E-05
7.150	-5.50144E-02	-2.48162E-02	-1.14015E-01	1.50694E-04	2.57330E-05
7.200	-3.34154E-02	-1.66010E-02	-1.14565E-01	1.60968E-04	2.58236E-05
7.250	-1.97815E-02	-6.32552E-03	-1.15480E-01	1.67900E-04	2.59439E-05
7.300	-1.32523E-02	4.82178E-03	-1.16574E-01	1.72100E-04	2.60674E-05
7.350	-1.33737E-02	1.51522E-02	-1.17580E-01	1.74652E-04	2.61812E-05
7.400	-2.05406E-02	2.36951E-02	-1.18221E-01	1.75968E-04	2.62718E-05
7.450	-3.56666E-02	3.08043E-02	-1.18282E-01	1.75197E-04	2.63116E-05
7.500	-5.93447E-02	3.77104E-02	-1.17637E-01	1.70650E-04	2.62540E-05
7.550	-9.11671E-02	4.54122E-02	-1.16208E-01	1.60911E-04	2.60428E-05
7.600	-1.29745E-01	5.38028E-02	-1.13891E-01	1.45777E-04	2.56273E-05
7.650	-1.73413E-01	6.17007E-02	-1.10516E-01	1.26322E-04	2.49725E-05
7.700	-2.21062E-01	6.77224E-02	-1.05864E-01	1.04031E-04	2.40557E-05
7.750	-2.72461E-01	7.12819E-02	-9.97410E-02	7.96884E-05	2.28551E-05
7.800	-3.27806E-01	7.29322E-02	-9.20459E-02	5.28590E-05	2.13381E-05
7.850	-3.86892E-01	7.38163E-02	-8.27791E-02	2.23691E-05	1.94623E-05
7.900	-4.48550E-01	7.46990E-02	-7.19922E-02	-1.26064E-05	1.71872E-05
7.950	-5.10826E-01	7.53562E-02	-5.97172E-02	-5.16853E-05	1.44905E-05
8.000	-5.71753E-01	7.47819E-02	-4.59323E-02	-9.33116E-05	1.13755E-05
8.050	-6.30122E-01	7.20105E-02	-3.05925E-02	-1.35653E-04	7.86600E-06
8.100	-6.85660E-01	6.68813E-02	-1.36997E-02	-1.77672E-04	3.99204E-06
8.150	-7.38483E-01	6.01488E-02	4.64317E-03	-2.19558E-04	-2.20674E-07
8.200	-7.88278E-01	5.28883E-02	2.42380E-02	-2.62194E-04	-4.75060E-06

Contrails

RUN NO 2

PAGE NO 11

TIME	P- 6	P- 7	P- 8	P- 9	P-10
5.500	-3.82307E-05	8.35416E 00	7.98058E-01	1.26498E 01	1.05575E 01
5.550	-3.72268E-05	9.52252E 00	5.93043E-01	1.28454E 01	1.16556E 01
5.600	-3.72278E-05	1.06215E 01	8.56250E-01	1.29776E 01	1.27494E 01
5.650	-3.70615E-05	1.16535E 01	1.44456E 00	1.30284E 01	1.37797E 01
5.700	-3.52057E-05	1.26560E 01	1.96164E 00	1.29933E 01	1.46924E 01
5.750	-3.09725E-05	1.36594E 01	2.06351E 00	1.28858E 01	1.54664E 01
5.800	-2.50493E-05	1.46497E 01	1.72416E 00	1.27286E 01	1.61182E 01
5.850	-1.89909E-05	1.55672E 01	1.25523E 00	1.25386E 01	1.66774E 01
5.900	-1.40639E-05	1.63409E 01	1.06423E 00	1.23166E 01	1.71552E 01
5.950	-1.03321E-05	1.69330E 01	1.33925E 00	1.20494E 01	1.75288E 01
6.000	-6.67851E-06	1.73589E 01	1.89312E 00	1.17241E 01	1.77536E 01
6.050	-1.73222E-06	1.76676E 01	2.33629E 00	1.13412E 01	1.77933E 01
6.100	5.01738E-06	1.78975E 01	2.33196E 00	1.09182E 01	1.76455E 01
6.150	1.27736E-05	1.80420E 01	1.89928E 00	1.04797E 01	1.73415E 01
6.200	1.99857E-05	1.80518E 01	1.37640E 00	1.00425E 01	1.69234E 01
6.250	2.54692E-05	1.78718E 01	1.16357E 00	9.60603E 00	1.64146E 01
6.300	2.92325E-05	1.74846E 01	1.41315E 00	9.15712E 00	1.58075E 01
6.350	3.23848E-05	1.69264E 01	1.91168E 00	8.68374E 00	1.50765E 01
6.400	3.62084E-05	1.62629E 01	2.24556E 00	8.18840E 00	1.42061E 01
6.450	4.11138E-05	1.55447E 01	2.12191E 00	7.69012E 00	1.32117E 01
6.500	4.62777E-05	1.47751E 01	1.59596E 00	7.21358E 00	1.21381E 01
6.550	5.02313E-05	1.39168E 01	1.02887E 00	6.77386E 00	1.10366E 01
6.600	5.19405E-05	1.29307E 01	8.08482E-01	6.36853E 00	9.93845E 00
6.650	5.15489E-05	1.18179E 01	1.04969E 00	5.98313E 00	8.84546E 00
6.700	5.02226E-05	1.06306E 01	1.50651E 00	5.60579E 00	7.74302E 00
6.750	4.92266E-05	9.44519E 00	1.76381E 00	5.23954E 00	6.62576E 00
6.800	4.89475E-05	8.31628E 00	1.56013E 00	4.90269E 00	5.51541E 00
6.850	4.86069E-05	7.24865E 00	9.90996E-01	4.61680E 00	4.45740E 00
6.900	4.68760E-05	6.20748E 00	4.35582E-01	4.39159E 00	3.49915E 00
6.950	4.29129E-05	5.15932E 00	2.63556E-01	4.21835E 00	2.66672E 00
7.000	3.70257E-05	4.11156E 00	5.49697E-01	4.07682E 00	1.95737E 00
7.050	3.04615E-05	3.11958E 00	1.01732E 00	3.95043E 00	1.35290E 00
7.100	2.44925E-05	2.25601E 00	1.25403E 00	3.83775E 00	8.43018E-01
7.150	1.95020E-05	1.56567E 00	1.03226E 00	3.75153E 00	4.40647E-01
7.200	1.47660E-05	1.04096E 00	4.85365E-01	3.70600E 00	1.77664E-01
7.250	9.08835E-06	6.36579E-01	6.37675E-03	3.70244E 00	8.48251E-02
7.300	1.79212E-06	3.11953E-01	-6.03276E-02	3.72429E 00	1.71337E-01
7.350	-6.69022E-06	6.82884E-02	3.18552E-01	3.74570E 00	4.19428E-01
7.400	-1.50756E-05	-4.84684E-02	8.38339E-01	3.74705E 00	7.97558E-01
7.450	-2.21315E-05	1.89292E-02	1.09385E 00	3.72545E 00	1.28179E 00
7.500	-2.75277E-05	2.95142E-01	8.93532E-01	3.69231E 00	1.86910E 00
7.550	-3.19924E-05	7.51927E-01	4.07136E-01	3.65990E 00	2.57285E 00
7.600	-3.66632E-05	1.32707E 00	3.30386E-02	3.62761E 00	3.40462E 00
7.650	-4.21377E-05	1.96787E 00	8.86825E-02	3.57852E 00	4.35634E 00
7.700	-4.79510E-05	2.66546E 00	5.64511E-01	3.48902E 00	5.39650E 00
7.750	-5.28747E-05	3.45358E 00	1.13182E 00	3.34403E 00	6.48284E 00
7.800	-5.58000E-05	4.37297E 00	1.39770E 00	3.14597E 00	7.58185E 00
7.850	-5.65303E-05	5.42918E 00	1.20872E 00	2.91058E 00	8.68043E 00
7.900	-5.58795E-05	6.57674E 00	7.68127E-01	2.65291E 00	9.78148E 00
7.950	-5.50115E-05	7.74198E 00	4.76229E-01	2.37430E 00	1.08874E 01
8.000	-5.45315E-05	8.86690E 00	6.18788E-01	2.06043E 00	1.19844E 01
8.050	-5.40241E-05	9.94030E 00	1.14519E 00	1.69189E 00	1.30397E 01
8.100	-5.23847E-05	1.09923E 01	1.70794E 00	1.25891E 00	1.40131E 01
8.150	-4.86834E-05	1.20570E 01	1.93193E 00	7.69023E-01	1.48749E 01
8.200	-4.28990E-05	1.31321E 01	1.70393E 00	2.41496E-01	1.56157E 01

Contrails

RUN NO 2

PAGE NO 12

TIME	P-11	P-12	P-13	P-14	P-15
5.500	-6.74352E-01	1.89089E 01	1.03281E-02	1.45375E-02	
5.550	-7.89643E-01	1.88784E 01	1.04720E-02	1.45439E-02	
5.600	-1.18947E 00	1.87557E 01	1.05659E-02	1.44735E-02	
5.650	-1.57368E 00	1.85509E 01	1.06114E-02	1.43268E-02	
5.700	-1.66013E 00	1.82620E 01	1.06076E-02	1.41086E-02	
5.750	-1.39933E 00	1.78806E 01	1.05501E-02	1.38262E-02	
5.800	-1.00670E 00	1.74028E 01	1.04345E-02	1.34870E-02	
5.850	-7.92243E-01	1.68381E 01	1.02593E-02	1.30962E-02	
5.900	-9.22065E-01	1.62076E 01	1.00278E-02	1.26570E-02	
5.950	-1.29511E 00	1.55352E 01	9.74708E-03	1.21728E-02	
6.000	-1.62626E 00	1.48358E 01	9.42452E-03	1.16497E-02	
6.050	-1.66761E 00	1.41128E 01	9.06555E-03	1.10971E-02	
6.100	-1.39618E 00	1.33628E 01	8.67326E-03	1.05266E-02	
6.150	-1.02607E 00	1.25870E 01	8.25079E-03	9.94854E-03	
6.200	-8.39973E-01	1.17976E 01	7.80426E-03	9.37090E-03	
6.250	-9.72684E-01	1.10164E 01	7.34385E-03	8.79897E-03	
6.300	-1.31232E 00	1.02653E 01	6.88196E-03	8.23752E-03	
6.350	-1.59138E 00	9.55686E 00	6.42973E-03	7.69293E-03	
6.400	-1.59378E 00	8.89153E 00	5.99434E-03	7.17364E-03	
6.450	-1.31768E 00	8.26381E 00	5.57891E-03	6.68859E-03	
6.500	-9.71755E-01	7.67181E 00	5.18495E-03	6.24471E-03	
6.550	-8.11759E-01	7.12334E 00	4.81530E-03	5.84533E-03	
6.600	-9.45628E-01	6.63365E 00	4.47518E-03	5.49060E-03	
6.650	-1.25554E 00	6.21668E 00	4.17053E-03	5.17952E-03	
6.700	-1.49308E 00	5.87669E 00	3.90493E-03	4.91199E-03	
6.750	-1.47080E 00	5.60636E 00	3.67751E-03	4.68931E-03	
6.800	-1.20277E 00	5.39287E 00	3.48359E-03	4.51280E-03	
6.850	-8.88910E-01	5.22692E 00	3.31765E-03	4.38167E-03	
6.900	-7.59155E-01	5.10792E 00	3.17649E-03	4.29180E-03	
6.950	-8.99025E-01	5.04156E 00	3.06027E-03	4.23647E-03	
7.000	-1.18889E 00	5.03169E 00	2.97084E-03	4.20841E-03	
7.050	-1.39983E 00	5.07299E 00	2.90863E-03	4.20174E-03	
7.100	-1.36939E 00	5.14990E 00	2.87070E-03	4.21245E-03	
7.150	-1.12258E 00	5.24274E 00	2.85143E-03	4.23706E-03	
7.200	-8.48130E-01	5.33605E 00	2.84528E-03	4.27069E-03	
7.250	-7.51961E-01	5.42324E 00	2.84949E-03	4.30608E-03	
7.300	-9.01597E-01	5.50402E 00	2.86459E-03	4.33426E-03	
7.350	-1.17899E 00	5.57701E 00	2.89213E-03	4.34655E-03	
7.400	-1.37428E 00	5.63339E 00	2.93148E-03	4.33623E-03	
7.450	-1.34612E 00	5.65633E 00	2.97790E-03	4.29882E-03	
7.500	-1.12609E 00	5.62694E 00	3.02340E-03	4.23085E-03	
7.550	-8.90298E-01	5.53184E 00	3.05968E-03	4.12803E-03	
7.600	-8.23144E-01	5.36717E 00	3.08078E-03	3.98443E-03	
7.650	-9.78526E-01	5.13583E 00	3.08358E-03	3.79322E-03	
7.700	-1.24271E 00	4.84067E 00	3.06576E-03	3.54851E-03	
7.750	-1.42391E 00	4.47866E 00	3.02306E-03	3.24689E-03	
7.800	-1.39800E 00	4.04057E 00	2.94796E-03	2.88763E-03	
7.850	-1.19957E 00	3.51637E 00	2.83118E-03	2.47151E-03	
7.900	-9.91701E-01	2.90199E 00	2.66484E-03	1.99917E-03	
7.950	-9.40382E-01	2.20251E 00	2.44520E-03	1.47044E-03	
8.000	-1.09006E 00	1.42942E 00	2.17290E-03	8.84958E-04	
8.050	-1.33338E 00	5.94131E-01	1.85086E-03	2.43809E-04	
8.100	-1.49513E 00	-2.97395E-01	1.48134E-03	-4.49212E-04	
8.150	-1.46469E 00	-1.24487E 00	1.06473E-03	-1.18759E-03	
8.200	-1.27691E 00	-2.24889E 00	6.00734E-04	-1.96336E-03	

Contrails

RUN NO 2

PAGE NO 13

TIME SEC	VX IN/SEC	VY IN/SEC	VZ IN/SEC	OMEGAX RAD/SEC	OMEGAY RAD/SEC	OMEGAZ RAD/SEC
8.250	0.	0.	0.	4.9485E-01	-1.6580E-04	4.4015E-07
8.300	0.	0.	0.	4.9463E-01	-1.5470E-04	-1.4555E-06
8.350	0.	0.	0.	4.9442E-01	-1.4500E-04	-4.2147E-06
8.400	0.	0.	0.	4.9423E-01	-1.3594E-04	-6.4589E-06
8.450	0.	0.	0.	4.9409E-01	-1.2512E-04	-7.0924E-06
8.500	0.	0.	0.	4.9403E-01	-1.1052E-04	-6.2803E-06
8.550	0.	0.	0.	4.9404E-01	-9.2231E-05	-5.3843E-06
8.600	0.	0.	0.	4.9411E-01	-7.2571E-05	-5.8419E-06
8.650	0.	0.	0.	4.9420E-01	-5.4471E-05	-7.9241E-06
8.700	0.	0.	0.	4.9431E-01	-3.9414E-05	-1.0455E-05
8.750	0.	0.	0.	4.9445E-01	-2.6501E-05	-1.1760E-05
8.800	0.	0.	0.	4.9463E-01	-1.3366E-05	-1.1045E-05
8.850	0.	0.	0.	4.9488E-01	1.7758E-06	-9.0254E-06
8.900	0.	0.	0.	4.9519E-01	1.8553E-05	-7.2983E-06
8.950	0.	0.	0.	4.9553E-01	3.4553E-05	-7.0112E-06
9.000	0.	0.	0.	4.9588E-01	4.7029E-05	-7.9752E-06
9.050	0.	0.	0.	4.9620E-01	5.4868E-05	-8.9247E-06
9.100	0.	0.	0.	4.9653E-01	5.9289E-05	-8.6268E-06
9.150	0.	0.	0.	4.9687E-01	6.2756E-05	-6.8579E-06
9.200	0.	0.	0.	4.9724E-01	6.6964E-05	-4.4666E-06
9.250	0.	0.	0.	4.9763E-01	7.1467E-05	-2.5804E-06
9.300	0.	0.	0.	4.9800E-01	7.3997E-05	-1.7104E-06
9.350	0.	0.	0.	4.9833E-01	7.2205E-05	-1.4893E-06
9.400	0.	0.	0.	4.9861E-01	6.5464E-05	-1.1468E-06
9.450	0.	0.	0.	4.9885E-01	5.5345E-05	-2.0204E-07
9.500	0.	0.	0.	4.9906E-01	4.4433E-05	1.2291E-06
9.550	0.	0.	0.	4.9927E-01	3.4413E-05	2.6735E-06
9.600	0.	0.	0.	4.9946E-01	2.4893E-05	3.7585E-06
9.650	0.	0.	0.	4.9960E-01	1.3854E-05	4.4532E-06
9.700	0.	0.	0.	4.9968E-01	-6.4232E-07	4.9561E-06
9.750	0.	0.	0.	4.9968E-01	-1.8825E-05	5.4335E-06
9.800	0.	0.	0.	4.9962E-01	-3.8884E-05	5.8902E-06
9.850	0.	0.	0.	4.9953E-01	-5.8177E-05	6.2414E-06
9.900	0.	0.	0.	4.9942E-01	-7.5045E-05	6.4433E-06
9.950	0.	0.	0.	4.9929E-01	-8.9840E-05	6.5260E-06
10.000	0.	0.	0.	4.9911E-01	-1.0442E-04	6.5297E-06
10.050	0.	0.	0.	4.9888E-01	-1.2050E-04	6.4578E-06

Contrails

RUN NO 2

PAGE NO 14

TIME	P- 1	P- 2	P- 3	P- 4	P- 5
8.250	-8.33872E-01	4.56968E-02	4.48526E-02	-3.06084E-04	-9.56965E-06
8.300	-8.73537E-01	3.83286E-02	6.62906E-02	-3.50575E-04	-1.46315E-05
8.350	-9.05795E-01	3.00257E-02	8.84162E-02	-3.93963E-04	-1.98691E-05
8.400	-9.30095E-01	2.02439E-02	1.11117E-01	-4.34410E-04	-2.52054E-05
8.450	-9.46837E-01	9.17976E-03	1.34239E-01	-4.70964E-04	-3.05687E-05
8.500	-9.56732E-01	-2.30911E-03	1.57542E-01	-5.03897E-04	-3.59036E-05
8.550	-9.60020E-01	-1.32928E-02	1.80723E-01	-5.34132E-04	-4.11692E-05
8.600	-9.56155E-01	-2.33751E-02	2.03482E-01	-5.62188E-04	-4.63278E-05
8.650	-9.44216E-01	-3.28370E-02	2.25585E-01	-5.87475E-04	-5.13336E-05
8.700	-9.23711E-01	-4.22330E-02	2.46876E-01	-6.08474E-04	-5.61315E-05
8.750	-8.95135E-01	-5.17965E-02	2.67235E-01	-6.23669E-04	-6.06671E-05
8.800	-8.59840E-01	-6.11426E-02	2.86511E-01	-6.32513E-04	-6.49000E-05
8.850	-8.19326E-01	-6.94908E-02	3.04491E-01	-6.35692E-04	-6.88093E-05
8.900	-7.74497E-01	-7.61994E-02	3.20928E-01	-6.34496E-04	-7.23880E-05
8.950	-7.25480E-01	-8.11654E-02	3.35613E-01	-6.29790E-04	-7.56285E-05
9.000	-6.72120E-01	-8.47759E-02	3.48424E-01	-6.21371E-04	-7.85119E-05
9.050	-6.14753E-01	-8.74792E-02	3.59329E-01	-6.08213E-04	-8.10077E-05
9.100	-5.54641E-01	-8.93486E-02	3.68331E-01	-5.89396E-04	-8.30848E-05
9.150	-4.93705E-01	-8.99962E-02	3.75406E-01	-5.65017E-04	-8.47240E-05
9.200	-4.33766E-01	-8.88901E-02	3.80481E-01	-5.36356E-04	-8.59226E-05
9.250	-3.75883E-01	-8.57921E-02	3.83471E-01	-5.05202E-04	-8.66880E-05
9.300	-3.20297E-01	-8.09459E-02	3.84345E-01	-4.72824E-04	-8.70246E-05
9.350	-2.67003E-01	-7.48740E-02	3.83172E-01	-4.39395E-04	-8.69273E-05
9.400	-2.16488E-01	-6.79680E-02	3.80103E-01	-4.04285E-04	-8.63846E-05
9.450	-1.70040E-01	-6.02289E-02	3.75313E-01	-3.66992E-04	-8.53921E-05
9.500	-1.29367E-01	-5.13675E-02	3.68940E-01	-3.27982E-04	-8.39647E-05
9.550	-9.58304E-02	-4.11678E-02	3.61073E-01	-2.88787E-04	-8.21392E-05
9.600	-6.98919E-02	-2.97929E-02	3.51797E-01	-2.51272E-04	-7.99658E-05
9.650	-5.11861E-02	-1.77698E-02	3.41251E-01	-2.16646E-04	-7.74946E-05
9.700	-3.91658E-02	-5.67140E-03	3.29659E-01	-1.84952E-04	-7.47689E-05
9.750	-3.37915E-02	6.22903E-03	3.17306E-01	-1.55435E-04	-7.18284E-05
9.800	-3.57199E-02	1.80313E-02	3.04468E-01	-1.27474E-04	-6.87204E-05
9.850	-4.58437E-02	2.99506E-02	2.91356E-01	-1.01372E-04	-6.55074E-05
9.900	-6.45501E-02	4.19529E-02	2.78119E-01	-7.83837E-05	-6.22654E-05
9.950	-9.12843E-02	5.36056E-02	2.64887E-01	-5.99676E-05	-5.90709E-05
10.000	-1.24763E-01	6.42784E-02	2.51827E-01	-4.68337E-05	-5.59874E-05
10.050	-1.63667E-01	7.35300E-02	2.39167E-01	-3.85254E-05	-5.30582E-05

Contrails

RUN NO 2

PAGE NO 15

TIME	P- 6	P- 7	P- 8	P- 9	P-10
8.250	-3.59660E-05	1.41677E 01	1.25824E 00	-3.06781E-01	1.62429E 01
8.300	-2.91039E-05	1.50925E 01	9.92851E-01	-8.73145E-01	1.67647E 01
8.350	-2.29484E-05	1.58570E 01	1.15979E 00	-1.46949E 00	1.71766E 01
8.400	-1.71435E-05	1.64613E 01	1.66994E 00	-2.11083E 00	1.74585E 01
8.450	-1.07013E-05	1.69449E 01	2.16289E 00	-2.80104E 00	1.75855E 01
8.500	-2.84568E-06	1.73480E 01	2.28671E 00	-3.52674E 00	1.75432E 01
8.550	6.30796E-06	1.76737E 01	1.96976E 00	-4.26402E 00	1.73374E 01
8.600	1.57531E-05	1.78807E 01	1.47444E 00	-4.99278E 00	1.69894E 01
8.650	2.42679E-05	1.79122E 01	1.19217E 00	-5.70755E 00	1.65225E 01
8.700	3.12471E-05	1.77383E 01	1.33969E 00	-6.41654E 00	1.59487E 01
8.750	3.70577E-05	1.73791E 01	1.79225E 00	-7.12977E 00	1.52657E 01
8.800	4.26537E-05	1.68911E 01	2.18221E 00	-7.84566E 00	1.44665E 01
8.850	4.87520E-05	1.63267E 01	2.18508E 00	-8.54656E 00	1.35534E 01
8.900	5.52018E-05	1.56992E 01	1.77080E 00	-9.20684E 00	1.25460E 01
8.950	6.10261E-05	1.49799E 01	1.22583E 00	-9.80725E 00	1.14778E 01
9.000	6.51006E-05	1.41285E 01	9.30226E-01	-1.03447E 01	1.03831E 01
9.050	6.69476E-05	1.31348E 01	1.06378E 00	-1.08298E 01	9.28472E 00
9.100	6.70424E-05	1.20368E 01	1.46890E 00	-1.12747E 01	8.19047E 00
9.150	6.64034E-05	1.09034E 01	1.77545E 00	-1.16801E 01	7.10159E 00
9.200	6.57858E-05	9.79349E 00	1.68936E 00	-1.20319E 01	6.02559E 00
9.250	6.50949E-05	8.72390E 00	1.22053E 00	-1.23108E 01	4.98424E 00
9.300	6.34647E-05	7.67056E 00	6.74242E-01	-1.25053E 01	4.01040E 00
9.350	5.99367E-05	6.60115E 00	4.14021E-01	-1.26209E 01	3.13621E 00
9.400	5.42169E-05	5.51409E 00	5.81094E-01	-1.26754E 01	2.38106E 00
9.450	4.69346E-05	4.45306E 00	9.87628E-01	-1.26861E 01	1.74816E 00
9.500	3.92099E-05	3.48605E 00	1.26519E 00	-1.26581E 01	1.23183E 00
9.550	3.18626E-05	2.66483E 00	1.15182E 00	-1.25817E 01	8.30014E-01
9.600	2.48668E-05	1.99655E 00	6.94642E-01	-1.24429E 01	5.52340E-01
9.650	1.74637E-05	1.44875E 00	2.11915E-01	-1.22364E 01	4.17958E-01
9.700	8.83961E-06	9.83755E-01	4.56149E-02	-1.19726E 01	4.44579E-01
9.750	-1.15208E-06	5.95424E-01	2.97379E-01	-1.16727E 01	6.36915E-01
9.800	-1.17758E-05	3.19658E-01	7.52167E-01	-1.13553E 01	9.83006E-01
9.850	-2.18684E-05	2.10730E-01	1.04723E 00	-1.10254E 01	1.46114E 00
9.900	-3.06141E-05	3.01864E-01	9.53861E-01	-1.06745E 01	2.05221E 00
9.950	-3.80494E-05	5.80630E-01	5.53156E-01	-1.02907E 01	2.74842E 00
10.000	-4.49182E-05	9.98043E-01	1.70799E-01	-9.87212E 00	3.55195E 00
10.050	-5.19918E-05	1.50408E 00	1.23158E-01	-9.43225E 00	4.46473E 00

Contrails

RUN NO 2

PAGE NO 16

TIME	P-11	P-12	P-13	P-14	P-15
8.250	-1.08230E 00	-3.30480E 00	9.11169E-05	-2.76873E-03	
8.300	-1.03180E 00	-4.40003E 00	-4.58285E-04	-3.59691E-03	
8.350	-1.16414E 00	-5.51678E 00	-1.03801E-03	-4.44167E-03	
8.400	-1.37959E 00	-6.63807E 00	-1.63764E-03	-5.29603E-03	
8.450	-1.51749E 00	-7.75264E 00	-2.24890E-03	-6.15128E-03	
8.500	-1.47727E 00	-8.85525E 00	-2.86695E-03	-6.99714E-03	
8.550	-1.29191E 00	-9.94223E 00	-3.48907E-03	-7.82299E-03	
8.600	-1.10037E 00	-1.10060E 01	-4.11193E-03	-8.61949E-03	
8.650	-1.04191E 00	-1.20325E 01	-4.72974E-03	-9.37928E-03	
8.700	-1.15260E 00	-1.30041E 01	-5.33460E-03	-1.00966E-02	
8.750	-1.34077E 00	-1.39048E 01	-5.91894E-03	-1.07662E-02	
8.800	-1.45786E 00	-1.47251E 01	-6.47811E-03	-1.13818E-02	
8.850	-1.41000E 00	-1.54622E 01	-7.01100E-03	-1.19369E-02	
8.900	-1.22682E 00	-1.61160E 01	-7.51825E-03	-1.24253E-02	
8.950	-1.03717E 00	-1.66838E 01	-7.99923E-03	-1.28425E-02	
9.000	-9.71831E-01	-1.71580E 01	-8.45016E-03	-1.31865E-02	
9.050	-1.06654E 00	-1.75286E 01	-8.86457E-03	-1.34569E-02	
9.100	-1.23728E 00	-1.77878E 01	-9.23583E-03	-1.36545E-02	
9.150	-1.34474E 00	-1.79350E 01	-9.55967E-03	-1.37790E-02	
9.200	-1.29878E 00	-1.79764E 01	-9.83483E-03	-1.38300E-02	
9.250	-1.12469E 00	-1.79215E 01	-1.00613E-02	-1.38075E-02	
9.300	-9.43017E-01	-1.77774E 01	-1.02380E-02	-1.37132E-02	
9.350	-8.78958E-01	-1.75472E 01	-1.03609E-02	-1.35509E-02	
9.400	-9.69517E-01	-1.72307E 01	-1.04247E-02	-1.33263E-02	
9.450	-1.13722E 00	-1.68303E 01	-1.04251E-02	-1.30459E-02	
9.500	-1.24901E 00	-1.63541E 01	-1.03618E-02	-1.27152E-02	
9.550	-1.21576E 00	-1.58166E 01	-1.02385E-02	-1.23394E-02	
9.600	-1.05821E 00	-1.52342E 01	-1.00615E-02	-1.19237E-02	
9.650	-8.90662E-01	-1.46208E 01	-9.83653E-03	-1.14747E-02	
9.700	-8.35380E-01	-1.39847E 01	-9.56773E-03	-1.10009E-02	
9.750	-9.31578E-01	-1.33302E 01	-9.25822E-03	-1.05119E-02	
9.800	-1.10671E 00	-1.26627E 01	-8.91262E-03	-1.00171E-02	
9.850	-1.23102E 00	-1.19919E 01	-8.53885E-03	-9.52485E-03	
9.900	-1.21443E 00	-1.13324E 01	-8.14792E-03	-9.04182E-03	
9.950	-1.07351E 00	-1.06998E 01	-7.75152E-03	-8.57386E-03	
10.000	-9.18799E-01	-1.01062E 01	-7.35913E-03	-8.12706E-03	
10.050	-8.72041E-01	-9.55686E 00	-6.97653E-03	-7.70816E-03	

TABLE 21
LISTINGS OF COMPUTER RUNS FOR RESPONSE TO INITIAL DEFORMATION

RUN NO 3 PAGE NO 1
PANDORA - LVV420 15 AUG 1963
RESPONSE OF TITAN III MODEL TO INITIAL DISPLACEMENTS IN ITS 1ST MODE

TIME SEC	VX IN/SEC	VY IN/SEC	VZ IN/SEC	OMEGAX RAD/SEC	OMEGAY RAD/SEC	OMEGAZ RAD/SEC
0.	0.	0.	0.	3.1607E-08	-7.5956E-09	4.8966E-13
0.100	0.	0.	0.	-3.4335E-23	-5.6986E-23	2.2879E-23
0.200	0.	0.	0.	3.5930E-20	2.8402E-21	-3.3608E-23
0.300	0.	0.	0.	-4.6006E-20	-1.8905E-21	-5.9059E-23
0.400	0.	0.	0.	-9.1603E-21	5.6151E-22	-8.0869E-23
0.500	0.	0.	0.	2.5081E-20	2.7815E-21	-4.0275E-23
0.600	0.	0.	0.	-1.3041E-20	5.0833E-22	-4.4969E-23
0.700	0.	0.	0.	-1.7665E-20	2.0467E-22	-2.6333E-23
0.800	0.	0.	0.	6.7122E-21	1.6087E-21	-9.4643E-24
0.900	0.	0.	0.	-1.3204E-22	1.0621E-21	-1.5445E-23
1.000	0.	0.	0.	-9.8119E-21	3.1537E-22	-3.7387E-23
1.100	0.	0.	0.	-1.5407E-21	6.5736E-22	-5.8698E-23
1.200	0.	0.	0.	9.5621E-22	6.5911E-22	-8.9278E-23
1.300	0.	0.	0.	-2.8005E-21	3.0510E-22	-7.6628E-23
1.400	0.	0.	0.	-1.9120E-21	2.6902E-22	-7.0316E-23
1.500	0.	0.	0.	-6.8320E-22	2.9053E-22	-6.5299E-23
1.600	0.	0.	0.	-8.6971E-22	2.5799E-22	-6.5449E-23
1.700	0.	0.	0.	-7.2262E-22	2.6797E-22	-6.3629E-23
1.800	0.	0.	0.	-1.4168E-21	2.3444E-22	-5.6943E-23
1.900	0.	0.	0.	-1.3776E-21	2.3701E-22	-5.4815E-23
2.000	0.	0.	0.	-2.8744E-22	2.7902E-22	-4.8226E-23
2.100	0.	0.	0.	-7.2223E-22	1.8981E-22	-5.1501E-23
2.200	0.	0.	0.	-1.0682E-21	5.8901E-23	-5.3456E-23
2.300	0.	0.	0.	4.1439E-22	-1.0077E-23	-5.2988E-23
2.400	0.	0.	0.	1.1942E-21	-1.6722E-22	-5.1057E-23
2.500	0.	0.	0.	1.0817E-21	-4.1324E-22	-8.7380E-23
2.600	0.	0.	0.	2.2426E-21	-5.9921E-22	-8.3836E-23
2.700	0.	0.	0.	3.5887E-21	-7.7062E-22	-9.1126E-23
2.800	0.	0.	0.	3.8103E-21	-9.8487E-22	-9.9311E-23
2.900	0.	0.	0.	4.2363E-21	-1.1392E-21	-8.9006E-23
3.000	0.	0.	0.	5.0501E-21	-1.2037E-21	-5.8225E-23
3.100	0.	0.	0.	5.0672E-21	-1.2376E-21	-1.9577E-23
3.200	0.	0.	0.	4.6380E-21	-1.2134E-21	-1.9857E-23
3.300	0.	0.	0.	4.3973E-21	-1.0942E-21	-1.2945E-23
3.400	0.	0.	0.	3.8257E-21	-9.2087E-22	-5.5037E-24
3.500	0.	0.	0.	2.8019E-21	-7.1698E-22	-1.2010E-23
3.600	0.	0.	0.	1.8389E-21	-4.7236E-22	-2.5300E-23
3.700	0.	0.	0.	9.2397E-22	-2.1159E-22	-4.1781E-23
3.800	0.	0.	0.	-1.1101E-22	3.1114E-23	-2.1249E-23
3.900	0.	0.	0.	-1.0310E-21	2.4845E-22	-3.2438E-23
4.000	0.	0.	0.	-1.7041E-21	4.3151E-22	3.2839E-25
4.100	0.	0.	0.	-2.2289E-21	5.6359E-22	-1.3349E-24
4.200	0.	0.	0.	-2.5812E-21	6.4257E-22	2.3359E-23
4.300	0.	0.	0.	-2.7029E-21	6.7565E-22	1.9633E-23
4.400	0.	0.	0.	-2.6625E-21	6.6863E-22	9.9917E-24
4.500	0.	0.	0.	-2.5279E-21	6.3208E-22	3.4893E-24
4.600	0.	0.	0.	-2.3286E-21	5.8157E-22	-3.2947E-24
4.700	0.	0.	0.	-2.1228E-21	5.3114E-22	-3.8388E-24
4.800	0.	0.	0.	-1.9696E-21	4.9261E-22	-9.1628E-24
4.900	0.	0.	0.	-1.9006E-21	4.7527E-22	-7.4921E-24
5.000	0.	0.	0.	-1.9341E-21	4.8352E-22	-7.4096E-24
5.100	0.	0.	0.	-2.0671E-21	5.1658E-22	-1.1611E-23

Contrails

RUN NO 3

PAGE NO 2

TIME	P- 1	P- 2	P- 3	P- 4	P- 5
0.	0.	0.	-2.01887E-04	3.53009E-14	4.54992E-08
0.100	-7.91742E-14	5.83636E-14	-2.00961E-04	3.50388E-14	4.52905E-08
0.200	-4.89893E-14	2.43619E-15	-1.98191E-04	3.40470E-14	4.46662E-08
0.300	-2.04699E-14	-4.27604E-14	-1.93603E-04	3.20930E-14	4.36322E-08
0.400	-3.60898E-14	1.58315E-14	-1.87239E-04	2.95346E-14	4.21978E-08
0.500	-2.55284E-14	2.01237E-14	-1.79156E-04	2.66036E-14	4.03763E-08
0.600	6.66803E-15	-2.11988E-14	-1.69431E-04	2.36676E-14	3.81844E-08
0.700	1.32001E-14	-4.95164E-15	-1.58150E-04	2.13828E-14	3.56421E-08
0.800	1.67673E-14	1.61358E-14	-1.45419E-04	1.94534E-14	3.27729E-08
0.900	3.73197E-14	-3.94288E-15	-1.31353E-04	1.67990E-14	2.96030E-08
1.000	4.87219E-14	-8.58367E-15	-1.16083E-04	1.38384E-14	2.61614E-08
1.100	4.78094E-14	7.67775E-15	-9.97469E-05	9.33828E-15	2.24799E-08
1.200	5.25619E-14	3.97210E-15	-8.24961E-05	3.72331E-15	1.85921E-08
1.300	5.62014E-14	-4.87639E-15	-6.44885E-05	-1.62608E-15	1.45337E-08
1.400	4.92811E-14	2.07539E-15	-4.58892E-05	-7.19200E-15	1.03420E-08
1.500	4.08081E-14	5.24171E-15	-2.68689E-05	-1.16430E-14	6.05543E-09
1.600	3.36913E-14	-7.07246E-16	-7.60215E-06	-1.58369E-14	1.71329E-09
1.700	2.15138E-14	-9.65447E-17	1.17344E-05	-1.92019E-14	-2.64457E-09
1.800	6.57128E-15	3.55294E-15	3.09632E-05	-2.34651E-14	-6.97816E-09
1.900	-6.20247E-15	1.20494E-15	4.99080E-05	-2.83695E-14	-1.12477E-08
2.000	-1.88123E-14	-6.48826E-16	6.83949E-05	-3.23959E-14	-1.54141E-08
2.100	-3.18605E-14	1.18158E-15	8.62542E-05	-3.62549E-14	-1.94390E-08
2.200	-4.19535E-14	8.68031E-16	1.03322E-04	-4.09326E-14	-2.32856E-08
2.300	-4.86433E-14	-1.07297E-15	1.19442E-04	-4.47814E-14	-2.69186E-08
2.400	-5.31412E-14	-8.82162E-16	1.34466E-04	-4.80973E-14	-3.03046E-08
2.500	-5.42791E-14	-5.68014E-16	1.48257E-04	-5.04657E-14	-3.34125E-08
2.600	-5.12706E-14	-1.71376E-15	1.60687E-04	-5.16500E-14	-3.62140E-08
2.700	-4.52289E-14	-2.18265E-15	1.71643E-04	-5.22666E-14	-3.86831E-08
2.800	-3.66095E-14	-1.81782E-15	1.81025E-04	-5.24688E-14	-4.07974E-08
2.900	-2.53133E-14	-2.09179E-15	1.88745E-04	-5.24045E-14	-4.25373E-08
3.000	-1.23172E-14	-2.40334E-15	1.94734E-04	-5.22268E-14	-4.38870E-08
3.100	1.21421E-15	-2.00033E-15	1.98936E-04	-5.21676E-14	-4.48340E-08
3.200	1.47304E-14	-1.62086E-15	2.01313E-04	-5.20862E-14	-4.53697E-08
3.300	2.74412E-14	-1.44536E-15	2.01843E-04	-5.17180E-14	-4.54892E-08
3.400	3.82784E-14	-9.14105E-16	2.00521E-04	-5.08138E-14	-4.51913E-08
3.500	4.66065E-14	-1.99017E-16	1.97360E-04	-4.93187E-14	-4.44788E-08
3.600	5.20338E-14	3.42526E-16	1.92387E-04	-4.76311E-14	-4.33582E-08
3.700	5.41059E-14	9.20959E-16	1.85650E-04	-4.53341E-14	-4.18398E-08
3.800	5.26414E-14	1.60557E-15	1.77210E-04	-4.24920E-14	-3.99376E-08
3.900	4.78289E-14	2.13992E-15	1.67143E-04	-3.92700E-14	-3.76689E-08
4.000	3.99688E-14	2.51187E-15	1.55543E-04	-3.59888E-14	-3.50547E-08
4.100	2.95072E-14	2.82537E-15	1.42516E-04	-3.27567E-14	-3.21188E-08
4.200	1.71503E-14	2.97710E-15	1.28182E-04	-2.94163E-14	-2.88883E-08
4.300	3.71757E-15	2.89505E-15	1.12672E-04	-2.62781E-14	-2.53927E-08
4.400	-9.96161E-15	2.65367E-15	9.61275E-05	-2.31153E-14	-2.16642E-08
4.500	-2.30098E-14	2.26243E-15	7.87014E-05	-1.98485E-14	-1.77369E-08
4.600	-3.45648E-14	1.68511E-15	6.05533E-05	-1.53974E-14	-1.36468E-08
4.700	-4.38942E-14	9.74485E-16	4.18496E-05	-9.94995E-15	-9.43161E-09
4.800	-5.04105E-14	1.96341E-16	2.27620E-05	-4.26561E-15	-5.12985E-09
4.900	-5.36838E-14	-6.30679E-16	3.46556E-06	1.11251E-15	-7.81029E-10
5.000	-5.35017E-14	-1.46092E-15	-1.58626E-05	5.49419E-15	3.57495E-09
5.100	-4.98861E-14	-2.22031E-15	-3.50453E-05	9.68808E-15	7.89813E-09

Contrails

RUN NO 3

PAGE NO 3

TIME	P- 6	P- 7	P- 8	P- 9	P-10
0.	0.	0.	0.	7.96749E-03	0.
0.100	-5.24749E-18	1.42784E-12	-3.33248E-12	7.93094E-03	1.45958E-12
0.200	1.67454E-19	9.05074E-13	-1.48509E-13	7.82163E-03	8.81525E-13
0.300	4.42065E-18	4.03426E-13	2.46037E-12	7.64056E-03	3.43094E-13
0.400	-1.20954E-18	6.60659E-13	-9.01488E-13	7.38939E-03	6.55506E-13
0.500	-1.54923E-18	4.68396E-13	-1.18409E-12	7.07042E-03	4.62602E-13
0.600	2.34357E-18	-1.01742E-13	1.18737E-12	6.68658E-03	-1.41435E-13
0.700	6.75247E-19	-2.31949E-13	2.69993E-13	6.24140E-03	-2.49448E-13
0.800	-1.35213E-18	-3.06958E-13	-9.62800E-13	5.73896E-03	-3.04530E-13
0.900	5.04842E-19	-6.74598E-13	1.78879E-13	5.18386E-03	-6.86419E-13
1.000	7.75154E-19	-8.85980E-13	4.67616E-13	4.58120E-03	-8.90867E-13
1.100	-8.99179E-19	-8.80594E-13	-4.61811E-13	3.93652E-03	-8.62975E-13
1.200	-6.34596E-19	-9.68454E-13	-2.55382E-13	3.25571E-03	-9.48436E-13
1.300	4.20975E-20	-1.03624E-12	2.73685E-13	2.54504E-03	-1.01338E-12
1.400	-7.82404E-19	-9.18358E-13	-1.02649E-13	1.81102E-03	-8.78884E-13
1.500	-1.16991E-18	-7.68025E-13	-2.79686E-13	1.06038E-03	-7.20211E-13
1.600	-6.89380E-19	-6.38384E-13	7.57786E-14	3.00019E-04	-5.90308E-13
1.700	-8.31744E-19	-4.19314E-13	6.38168E-14	-4.63097E-04	-3.65278E-13
1.800	-1.18216E-18	-1.48553E-13	-1.37414E-13	-1.22196E-03	-9.10964E-14
1.900	-9.01154E-19	8.72593E-14	-8.64643E-16	-1.96962E-03	1.38940E-13
2.000	-6.46130E-19	3.20542E-13	1.12889E-13	-2.69921E-03	3.65528E-13
2.100	-6.81604E-19	5.62128E-13	6.97098E-15	-3.40403E-03	5.99800E-13
2.200	-4.43380E-19	7.53012E-13	1.18085E-14	-4.07762E-03	7.76997E-13
2.300	-2.54365E-20	8.83360E-13	1.09638E-13	-4.71379E-03	8.90622E-13
2.400	2.08297E-19	9.73399E-13	8.30151E-14	-5.30672E-03	9.64618E-13
2.500	4.58469E-19	1.00302E-12	4.05911E-14	-5.85097E-03	9.76493E-13
2.600	8.43077E-19	9.57536E-13	7.98139E-14	-6.34153E-03	9.12261E-13
2.700	1.12904E-18	8.55341E-13	8.31529E-14	-6.77391E-03	7.94120E-13
2.800	1.29973E-18	7.04619E-13	3.81104E-14	-7.14414E-03	6.30499E-13
2.900	1.47965E-18	5.03709E-13	3.08871E-14	-7.44883E-03	4.19447E-13
3.000	1.58496E-18	2.69303E-13	3.27229E-14	-7.68518E-03	1.79896E-13
3.100	1.53885E-18	2.21354E-14	3.12365E-16	-7.85102E-03	-6.64164E-14
3.200	1.41360E-18	-2.27362E-13	-2.50841E-14	-7.94483E-03	-3.09842E-13
3.300	1.22021E-18	-4.64903E-13	-3.03112E-14	-7.96574E-03	-5.35857E-13
3.400	9.09484E-19	-6.71120E-13	-4.67244E-14	-7.91358E-03	-7.24861E-13
3.500	5.15807E-19	-8.33773E-13	-6.68101E-14	-7.78881E-03	-8.65926E-13
3.600	8.98215E-20	-9.45026E-13	-7.07983E-14	-7.59258E-03	-9.52602E-13
3.700	-3.70453E-19	-9.96105E-13	-7.11337E-14	-7.32669E-03	-9.77092E-13
3.800	-8.44251E-19	-9.82853E-13	-7.45664E-14	-6.99358E-03	-9.36935E-13
3.900	-1.27873E-18	-9.07680E-13	-6.92555E-14	-6.59631E-03	-8.36600E-13
4.000	-1.64869E-18	-7.75283E-13	-5.62026E-14	-6.13853E-03	-6.82344E-13
4.100	-1.93971E-18	-5.93065E-13	-4.37843E-14	-5.62442E-03	-4.83039E-13
4.200	-2.11930E-18	-3.73123E-13	-2.89431E-14	-5.05871E-03	-2.52335E-13
4.300	-2.16578E-18	-1.29893E-13	-9.26417E-15	-4.44659E-03	-5.68315E-15
4.400	-2.07846E-18	1.21718E-13	9.89283E-15	-3.79367E-03	2.41574E-13
4.500	-1.85604E-18	3.65778E-13	2.68961E-14	-3.10595E-03	4.73370E-13
4.600	-1.50138E-18	5.86379E-13	4.36222E-14	-2.38974E-03	6.74172E-13
4.700	-1.03487E-18	7.69645E-13	5.79540E-14	-1.65160E-03	8.31140E-13
4.800	-4.84504E-19	9.04138E-13	6.74623E-14	-8.98303E-04	9.34291E-13
4.900	1.20608E-19	9.81129E-13	7.29383E-14	-1.36769E-04	9.76674E-13
5.000	7.43470E-19	9.95677E-13	7.44283E-14	6.26020E-04	9.55487E-13
5.100	1.34193E-18	9.47014E-13	7.07202E-14	1.38306E-03	8.72289E-13

Contrails

RUN NO 3

PAGE NO 4

TIME	P-11	P-12	P-13	P-14	P-15
0.	0.	7.96749E-03	6.26916E-06	6.26916E-06	
0.100	-3.58316E-12	7.93094E-03	6.24040E-06	6.24040E-06	
0.200	-2.07985E-13	7.82163E-03	6.15439E-06	6.15439E-06	
0.300	2.50532E-12	7.64056E-03	6.01191E-06	6.01191E-06	
0.400	-1.01196E-12	7.38939E-03	5.81428E-06	5.81428E-06	
0.500	-1.24606E-12	7.07042E-03	5.56330E-06	5.56330E-06	
0.600	1.24774E-12	6.68658E-03	5.26129E-06	5.26129E-06	
0.700	2.76369E-13	6.24140E-03	4.91100E-06	4.91100E-06	
0.800	-9.66479E-13	5.73896E-03	4.51565E-06	4.51565E-06	
0.900	2.61941E-13	5.14336E-03	4.07888E-06	4.07888E-06	
1.000	5.48889E-13	4.58120E-03	3.60468E-06	3.60468E-06	
1.100	-4.11289E-13	3.93652E-03	3.09742E-06	3.09742E-06	
1.200	-1.66588E-13	3.25571E-03	2.56173E-06	2.56173E-06	
1.300	3.73685E-13	2.54504E-03	2.00255E-06	2.00255E-06	
1.400	-3.87100E-14	1.81102E-03	1.42499E-06	1.42499E-06	
1.500	-2.18815E-13	1.06038E-03	8.34354E-07	8.34354E-07	
1.600	1.40164E-13	3.00019E-04	2.36067E-07	2.36067E-07	
1.700	9.51101E-14	-4.63097E-04	-3.64385E-07	-3.64385E-07	
1.800	-1.32183E-13	-1.22197E-03	-9.61494E-07	-9.61494E-07	
1.900	-2.77922E-15	-1.96962E-03	-1.54978E-06	-1.54978E-06	
2.000	8.76200E-14	-2.69921E-03	-2.12385E-06	-2.12385E-06	
2.100	-4.60063E-14	-3.40403E-03	-2.67843E-06	-2.67843E-06	
2.200	-5.05497E-14	-4.07752E-03	-3.20844E-06	-3.20844E-06	
2.300	3.88951E-14	-4.71379E-03	-3.70901E-06	-3.70901E-06	
2.400	-1.11957E-15	-5.30673E-03	-4.17556E-06	-4.17556E-06	
2.500	-4.47792E-14	-5.85097E-03	-4.60379E-06	-4.60379E-06	
2.600	2.34298E-15	-6.34153E-03	-4.98978E-06	-4.98978E-06	
2.700	1.17782E-14	-6.77391E-03	-5.33000E-06	-5.33000E-06	
2.800	-2.21203E-14	-7.14414E-03	-5.62131E-06	-5.62131E-06	
2.900	-9.68321E-15	-7.44883E-03	-5.86106E-06	-5.86106E-06	
3.000	1.18318E-14	-7.63918E-03	-6.04702E-06	-6.04702E-06	
3.100	-1.77919E-15	-7.85102E-03	-6.17751E-06	-6.17751E-06	
3.200	-5.35430E-15	-7.94483E-03	-6.25132E-06	-6.25132E-06	
3.300	1.02453E-14	-7.96574E-03	-6.26778E-06	-6.26778E-06	
3.400	9.85713E-15	-7.91358E-03	-6.22674E-06	-6.22674E-06	
3.500	3.01404E-15	-7.78881E-03	-6.12856E-06	-6.12856E-06	
3.600	9.04505E-15	-7.59258E-03	-5.97416E-06	-5.97416E-06	
3.700	1.24875E-14	-7.32669E-03	-5.76495E-06	-5.76495E-06	
3.800	7.14387E-15	-6.99359E-03	-5.50285E-06	-5.50285E-06	
3.900	6.33270E-15	-6.59631E-03	-5.19026E-06	-5.19026E-06	
4.000	8.26091E-15	-6.13853E-03	-4.83005E-06	-4.83005E-06	
4.100	4.81966E-15	-5.62442E-03	-4.42553E-06	-4.42553E-06	
4.200	1.12380E-15	-5.05871E-03	-3.98041E-06	-3.98041E-06	
4.300	6.18102E-16	-4.44659E-03	-3.49876E-06	-3.49876E-06	
4.400	-1.45267E-15	-3.79367E-03	-2.98502E-06	-2.98502E-06	
4.500	-4.95619E-15	-3.10595E-03	-2.44390E-06	-2.44390E-06	
4.600	-6.40524E-15	-2.38974E-03	-1.88035E-06	-1.88035E-06	
4.700	-7.18779E-15	-1.65160E-03	-1.29955E-06	-1.29955E-06	
4.800	-8.79844E-15	-8.98303E-04	-7.06823E-07	-7.06823E-07	
4.900	-9.42088E-15	-1.36768E-04	-1.07616E-07	-1.07616E-07	
5.000	-8.74078E-15	5.26020E-04	4.92579E-07	4.92579E-07	
5.100	-8.09257E-15	1.34306E-03	1.08825E-06	1.08825E-06	

APPENDIX II

A VIBRATION ANALYSIS OF A
ONE-FIFTH SCALE MODEL OF THE
SATURN VEHICLE

Contrails

TABLE OF CONTENTS

	<u>Page</u>
1.0 COMPONENT BREAKDOWN OF SATURN MODEL.	597
1.1 Introduction.	597
1.2 Saturn Model Components	597
2.0 ANALYSIS OF INDIVIDUAL COMPONENTS.	599
2.1 Upper Stage	599
2.1.1 Collation Point Geometry for Upper Stage	599
2.1.2 Analysis of Upper Stage.	599
2.2 Middle Stage.	602
2.2.1 Collation Point Geometry for Middle Stage.	602
2.2.2 Analysis of Middle Stage	602
2.3 Adapter	604
2.3.1 Generalized Coordinates for the Adapter.	604
2.3.2 Analysis of the Adapter.	605
2.4 Spider Beam	606
2.4.1 Collation Point Geometry for Spider Beam	606
2.4.2 Analysis of Spider Beam.	607
2.5 Center Lox Tank	608
2.5.1 Collation Point Geometry for Center Lox Tank	608
2.5.2 Analysis of Center Lox Tank.	609
2.6 Fuel Tanks.	610
2.6.1 Collation Point Geometry for Fuel Tanks.	610
2.6.2 Analysis of Fuel Tanks	611
2.7 Outrigger	612
2.7.1 Degrees-of-Freedom for Outrigger	612
2.7.2 Outrigger Analysis	613
3.0 COUPLING OF SATURN MODEL COMPONENT MODES	624
3.1 Introduction.	624
3.2 Vehicle without Outer Lox Tanks	624

Contracts

TABLE OF CONTENTS (Continued)

	<u>Page</u>
3.2.1 Components of Vehicle without Outer Lox Tanks	625
3.2.2 Modes of Vehicle without Outer Lox Tanks	629
3.3 Coupling of Outer Lox Tanks with the Rest of the Vehicle. . .	639
3.3.1 Analysis of Outer Lox Tanks.	639
3.3.1.1 Outer Lox Tank Geometry and Basic Data.	639
3.3.1.2 Outer Lox Tank Collation Point Geometry and Generalized Coordinates.	640
3.3.1.3 Outer Lox Tank Influence Coefficients and Modes	641
3.3.1.4 Outer Lox Tank Modal Transformation Matrix.	642
3.3.2 Geometric Transformation Relating Motion of Rigid Outer Lox Tank to Outrigger.	644
3.3.3 Spider - Outer Lox Tank Constraints.	646
3.3.4 Modal Coupling for Natural Modes of Complete Vehicle.	648
3.3.4.1 Constraint - Compatibility Matrix	649
3.3.4.2 Kinetic Energy.	651
3.3.4.3 Strain Energy	651
3.3.4.4 Vibration Modes and Frequencies	653

1.0 COMPONENT BREAKDOWN OF SATURN MODEL

1.1 Introduction

For the purpose of analysis, the Saturn Model was divided into eight (8) component structures. Each of these component structures was then analyzed independently by methods applicable to that particular type of structure. The selection of constraints for each of these component structures was based on the idealized constraints imposed by adjacent component structures such that each separate analysis was compatible with the idea of eventually coupling the component structures as described in Section 5.1.3. This final coupling process is presented in Section 3.0 of this Appendix.

1.2 Saturn Model Components

The component structures into which the Saturn Model was divided, their idealized constraints, and their unit designations are presented below. It should be noted that a completely darkened area indicates a portion of the vehicle which was considered rigid for the purpose of aiding in the final coupling of the components.

- (1) Upper (third) Stage and second stage adapter cantilevered from second stage. Designated as (U).

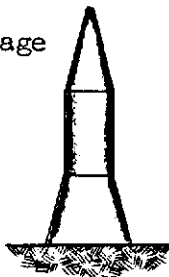

- (2) Middle (second) Stage cantilevered from a rigid first stage adapter. Designated by (M).

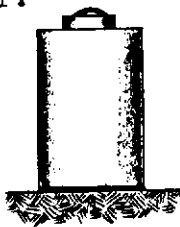

- (3) Adapter for first stage supported on the rigid spider beam. Designated as (A).

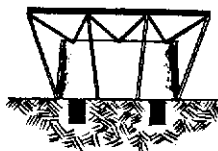

FIGURE 115 SATURN SA-1
LAUNCH VEHICLE

- (4) Spider Beam supported on eight simple supports (points of contact with center lox tank). Designated by (S).



- (5) Lox Tank in center of cluster cantilevered from outrigger. Designated by (L).



- (6) Fuel Tanks in outer cluster simply supported on spider beam and outrigger. Designated as (F).



- (7) Lox Tanks in the outer cluster pinned at bottom and free at top. Designated as (T).



FIGURE 116 COMPONENTS OF SATURN MODEL

- (8) Outrigger and engines considered as a rigid body. Designated as (R).

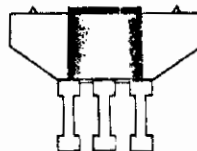

2.0 ANALYSIS OF INDIVIDUAL COMPONENTS

2.1 Upper Stage (U)

2.1.1 Collocation Point Geometry for Upper Stage

One of the basic assumptions in the analysis of the Upper Stage was that this portion of the vehicle could be represented by nine (9) collocation points. These points were spaced equidistant along the x axis (neutral axis) as shown in Figure 117.

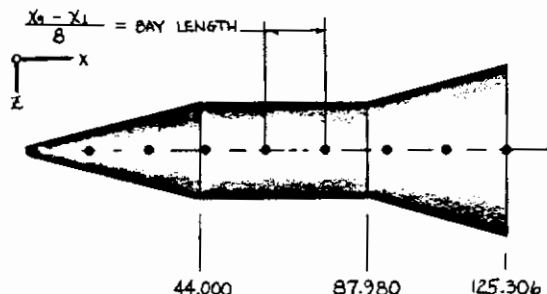

FIGURE 117 COLLOCATION POINT GEOMETRY

The x coordinates (body stations) of the assumed collocation points are presented in Table 22.

2.1.2 Analysis of Upper Stage

The analysis of the Upper Stage was based on the assumption that the elastic behavior of this portion of the vehicle could be determined through the use of equivalent beam theory. The use of this theory allowed the structure of this stage to be presented as a beam as shown in Figure 118.

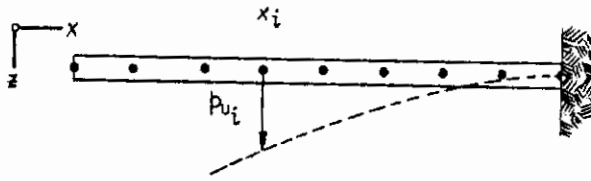

FIGURE 118 EQUIVALENT BEAM

The analysis of this equivalent beam allowed for not only a different total mass in each bay, but also the addition of concentrated mass items. This allowed the consideration of the lead ballast weights as point loads. This consideration displays itself in the computation of the point-mass matrix of the kinetic energy expression.

The kinetic energy of the equivalent beam was expressed in matrix form as,

$$\tau = \frac{1}{2} \{\dot{p}_0\}' [A_0] \dot{p}_0 \quad (\text{II-1})$$

where

$$[A_0] = \sum_{i=1}^g [\tau]'_i [A]_i [\tau]_i \quad (\text{II-2})$$

where $[A]_i$ was a function of the individual bay (see Paragraph 5.1.2.2) such that

$$[A]_i = m_i [\bar{A}]_i + \sum_j m_{ij} [\mathcal{J}]_j \begin{bmatrix} 1 & \xi_j & \xi_j^2 & \xi_j^3 \\ \xi_j & \xi_j^2 & \xi_j^3 & \xi_j^4 \\ \xi_j^2 & \xi_j^3 & \xi_j^4 & \xi_j^5 \\ \xi_j^3 & \xi_j^4 & \xi_j^5 & \xi_j^6 \end{bmatrix} [\mathcal{J}]_j \quad (\text{II-3})$$

where m_i was the total mass of the i th bay,
 m_{ij} was the j th concentrated mass in the i th bay (perhaps it should be noted that Equation II-3 is somewhat general in that if any particular bay did not have a concentrated mass, then the summation term was neglected or zero),
 ξ_j calculated from the position of the j^{th} concentrated mass in the i^{th} bay by the relation,

$$\xi_j = \frac{x_j - x_{i-1}}{x_i - x_{i-1}} \quad (\text{II-4})$$

Contrails

such that the matrix distributed the j th concentrated mass diparabolically between four collocation points (two to either side of the bay in which it was located). The $[\bar{A}]_i$ matrix in Equation II-3 was a non-dimensional matrix which distributed the total mass of the i th bay between four collocation points (two points on either side of the i th bay). Due to the absence of a fourth point in the case of the first and last bays, the elements of this matrix varied. This variation is shown below.

(II-5)

$$[\bar{A}]_i = \begin{cases} \frac{1}{6720} \begin{bmatrix} 0 & 0 & 0 & 0 \\ 0 & 1880 & 1224 & -164 \\ 0 & 1224 & 3264 & -288 \\ 0 & -164 & -288 & 32 \end{bmatrix} & \text{for } i = 1 \\ \frac{1}{6720} \begin{bmatrix} 16 & -188 & -120 & 12 \\ -188 & 2720 & 1228 & -120 \\ -120 & 1228 & 2720 & -188 \\ 12 & -120 & -188 & 16 \end{bmatrix} & \text{for } i = 2, 3, \dots, 7 \\ \frac{1}{6720} \begin{bmatrix} 32 & -288 & -164 & 0 \\ -288 & 3264 & 1224 & 0 \\ -164 & 1224 & 1880 & 0 \\ 0 & 0 & 0 & 0 \end{bmatrix} & \text{for } i = 8 \end{cases}$$

The remaining term in expression $[T]_i$, was a non-dimensional matrix which positioned the distributed mass of the i th bay in the final point-mass matrix $[A_U]$. This matrix is presented in Table 22.

The strain energy stored in the equivalent beam was expressed in terms of the applied loads P_{U_i} , as;

$$U = \frac{1}{2} \{P_U\}^T [E_U] \{P_U\} \tag{II-6}$$

where $[E_U]$, the collocation point influence coefficient matrix for the Upper Stage, was determined from EI and GA slice data (presented in Table 30), through the use of the complementary strain energy method presented in Section 5.1.1.2 of this report. This collocation point influence coefficient matrix for the Upper Stage is presented in Table 22.

The modes of the Upper Stage (cantilevered at $x = x_0 = 125.306$) and their respective eigenvalues were calculated by the iteration of the expression,

$$[E_0][A_0]H\varphi = \lambda\{\varphi\} \quad (\text{II-7})$$

These modes and their respective frequencies are presented in Table 22.

2.2 Middle Stage (M)

2.2.1 Collocation Point Geometry For Middle Stage

In the interest of additional accuracy, in the analysis of the Middle Stage the number of collocation points was increased to fifteen (six points more than were used in the analysis of the Upper Stage). These points were spaced equidistant along the x axis as shown in Figure 119.

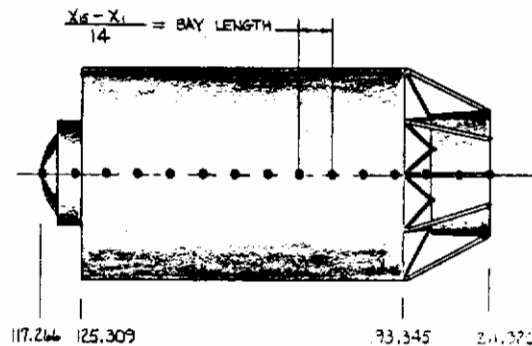

FIGURE 119 COLLOCATION POINT GEOMETRY FOR MIDDLE STAGE

The x coordinates of the Middle Stage collocation points are presented in Table 23.

2.2.2 Analysis of Middle Stage

The analysis of the Middle Stage was somewhat complicated by the structure found in the adapter portion of the stage (that portion of the stage between body stations 193.345 and 211.320). This portion of the stage did not lend itself to an analysis based on equivalent beam theory while the remaining portion did. It was therefore decided that the analysis of the Middle Stage should consist of two parts; (1) an analysis of the entire structure based on equivalent beam theory in which the adapter portion of the stage was considered rigid, and

(2) an analysis of the adapter as an independent structure based on complementary strain energy methods. It is the first part of the analysis which will be presented here.

The assumption that the adapter is rigid and the assumptions implied by the use of the equivalent beam theory lead to the idealization of the Middle Stage structure shown in Figure 120.

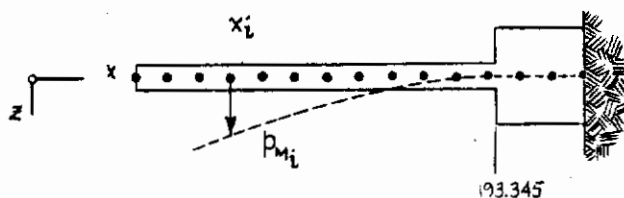

FIGURE 120 EQUIVALENT BEAM

In the analysis of this equivalent beam it was considered extremely advantageous to allow for the treatment of structural items such as ring stiffeners, radial members, plates, and tank caps as concentrated mass items. This allowance was made in the computation of the collocation point-mass matrix in the expression for kinetic energy.

The kinetic energy of this equivalent beam for the Middle Stage was expressed in matrix form as,

$$T = \frac{1}{2} \{\dot{p}_M\}' [A_M] \{\dot{p}_M\} \quad (II-8)$$

where

$$[A_M] = \sum_{i=1}^{14} [T]_i' [A]_i [T]_i \quad (II-9)$$

where $[A]_i$ was a function of the individual bay.

The final point mass matrix for the Middle Stage is presented in Table 23. It should be noted that the assumption that the adapter portion of the stage was rigid has had no effect whatsoever on the analysis thus far. This assumption has no bearing on the calculation of $[A_M]$.

The strain energy stored in the equivalent beam was expressed in terms of applied loads, P_{M_i} , as;

$$U = \frac{1}{2} \{P_M\}^T [E_M] \{P_M\} \quad (\text{II-10})$$

where $[E_M]$, the collocation point influence coefficient matrix for the Middle Stage, was determined from EI and GA slice data (presented in Table 30) through the use of the complementary strain energy method presented in Section 5.1.1.2 of this report. This collocation point influence coefficient matrix for the Middle Stage is presented in Table 24.

The modes of the Middle Stage and their respective frequencies were determined from the iteration of the expression;

$$[E_M][A_M]\{\varphi\} = \lambda\{\varphi\} \quad (\text{II-11})$$

These modes and their respective frequencies are presented in Table 24. These modes are actually for the Middle Stage cantilevered at $x = x_{15} = 211.320$, but due to the rigidity of the adapter section, they will appear as though the stage were cantilevered at $x = 193.345$.

2.3 Adapter (A)

2.3.1 Generalized Coordinates for the Adapter

One of the basic assumptions in the analysis of the adapter was that the elastic behavior of this portion of the Middle Stage could be described through the use of two degrees-of-freedom (ζ_A and θ_A). These degrees-of-freedom are shown in Figure 121.

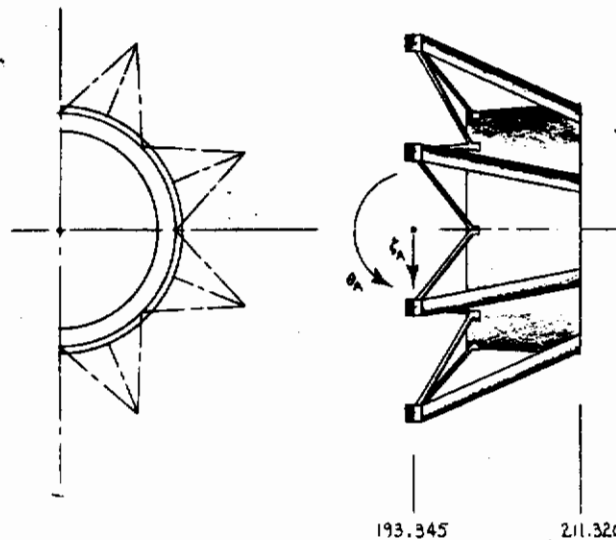

FIGURE 121 DEGREES-OF-FREEDOM FOR ADAPTER

As may be noted, the degrees-of-freedom selected here are only those of primary importance. With respect to the final analysis, ζ_A and θ_A adequately describe the elastic behavior of the adapter.

2.3.2 Analysis of the Adapter

The analysis of the adapter was based on the complementary strain energy method as presented in Section 5.1.1.2 of this report. Generalized loads were applied to an idealized version of the adapter structure as shown in Figure 122.

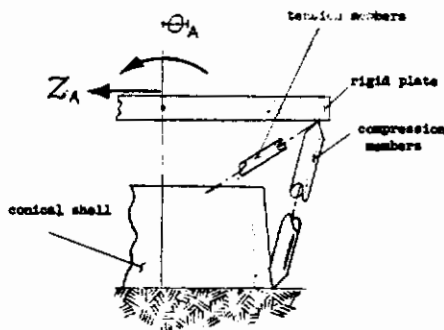

FIGURE 122 GENERALIZED ADAPTER LOADS

The strain energy stored in the tension members, compression members, and the conical shell was written in terms of the generalized loads, Z_A and θ_A (associated with the generalized coordinates ζ_A and θ_A), with the result that the total strain energy stored in the adapter was written as,

$$U = \frac{1}{2} \{ Z_A \ \theta_A \} [E_A] \begin{bmatrix} Z_A \\ \theta_A \end{bmatrix} \quad (\text{II-12})$$

where $[E_A]$ was found to be,

$$\begin{bmatrix} 4.4171320 \times 10^{-6} & 5.4094366 \times 10^{-5} \\ 5.4094366 \times 10^{-5} & 1.11365166 \times 10^{-3} \end{bmatrix} \quad (\text{II-13})$$

It should be noted that the mass of the adapter was included in the mass of the Middle Stage and therefore need not be considered in this analysis.

2.4 Spider Beam (S)

2.4.1 Collocation Point Geometry for Spider Beam

The primary interest in the selection of collocation points, and generalized coordinates, for the Spider Beam was the fact that this member coupled together the motions of the adapter, the center lox tank, and the four outer lox tanks. With this consideration in mind, eight (8) collocation points and eleven (11) generalized coordinates (the three additional coordinates were used to describe the rigid body displacements) were chosen and are shown in Figures 123 and 124, respectively.

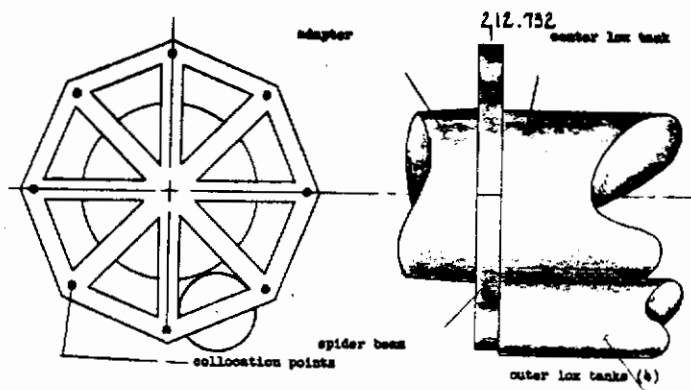

FIGURE 123 COLLOCATION POINT GEOMETRY FOR SPIDER BEAM

It should be noted that only the three rigid body displacements are displacements (of a point in the plane of the supports).

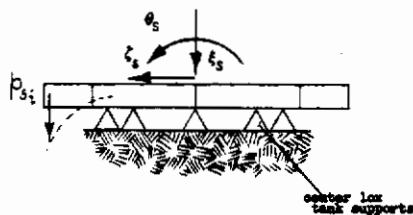

FIGURE 124 GENERALIZED COORDINATES FOR SPIDER BEAM

2.4.2 Analysis of Spider Beam

The analysis of the Spider Beam was based on the complementary strain energy method presented in Section 5.1.1.2 of this report. Generalized loads, associated with the generalized coordinates shown in Figure 12⁴ were applied to the structure, and the strain energy stored in each structural member written in terms of these loads. These expressions for strain energy in the individual members were then combined to form an expression for the total strain energy stored in the Spider Beam, which was;

$$U = \frac{1}{2} \{ P_s \quad z_s \quad Z_s \quad \theta_s \} [E_s] \begin{bmatrix} P_s \\ z_s \\ Z_s \\ \theta_s \end{bmatrix} \quad (\text{II-14})$$

where $[E_s]$ is the structural influence coefficient matrix presented in Table 25.

The x coordinates (body stations) of these points are presented in Table 26.

2.5.2 Analysis of Center Lox Tank

The analysis of the Center Lox Tank was based on the assumption that the elastic behavior of this portion of the vehicle could be determined through the use of equivalent beam theory. This assumption lead to the idealization of the structure shown in Figure 126.

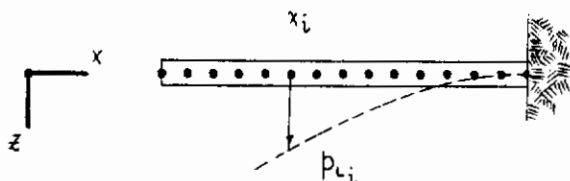

FIGURE 126 EQUIVALENT BEAM

In this analysis, it was considered advantageous with respect to accuracy to consider structural members such as ring stiffeners, tank caps, and plates as concentrated weight items. This consideration was made in the computation of the point-mass matrix used in the expression for kinetic energy. The kinetic energy for this equivalent beam was expressed in matrix form as,

$$T = \frac{1}{2} \{\dot{p}_L\}' [A_L] \{\dot{p}_L\} \quad (\text{II-17})$$

where

$$[A_L] = \sum_{i=1}^n [T]_i' [A]_i [T]_i \quad (\text{II-18})$$

where $[A]_i$ was a function of the individual bay. This final point-mass is presented in Table 26.

The strain energy stored in the equivalent beam was expressed in terms of the applied loads, P_i , as;

$$U = \frac{1}{2} \{P_L\}' [E_L] \{P_L\} \quad (\text{II-19})$$

where $[E_L]$, the collocation point influence coefficient matrix, was determined from EI and GA slice data (presented in Table 30) through the use of the complementary strain energy method presented in Section 5.1.1.2 of this report. This collocation point influence coefficient matrix for the Center Lox Tank is presented in Table 27.

The mode shapes for the Center Lox Tank were determined by the iteration of the expression,

$$[E_L][A_L H \varphi] = \lambda \{\varphi\} \quad (\text{II-20})$$

The mode shapes for the Center Lox Tank cantilevered at $x = x_{15} = 350.409$ and their respective frequencies are presented in Table 27.

2.6 Fuel Tanks (F)

2.6.1 Collocation Point Geometry for Fuel Tanks

Each of the Fuel Tanks were analyzed on the basis of fifteen (15) collocation points. These points were equally spaced along the x axis (neutral axis) as shown in Figure 127. These points were chosen in preparation for an analysis based on equivalent beam theory. It was thought that due to the absence of both axial loading and internal pressure, the application of thin shell vibration theory was not necessary.

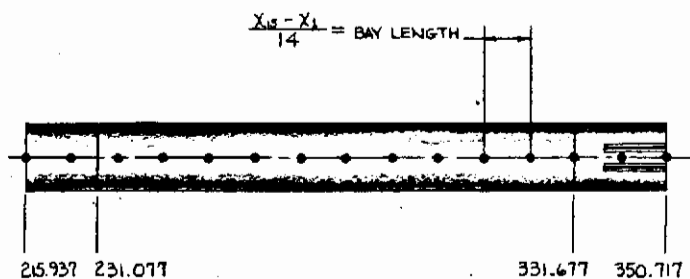

FIGURE 127 COLLOCATION POINT GEOMETRY
FOR FUEL TANK

It should be noted that the collocation point selection and resulting analysis was the same for each of the four Fuel Tanks. Although a small asymmetry did exist in the complementary bending planes, it was found that this condition did not appreciably affect the final results and was therefore ignored.

2.6.2 Analysis of Fuel Tanks

The analysis of each of the four Fuel Tanks was based on the equivalent beam theory. This assumption implied that the elastic behavior of the Fuel Tanks could be determined by analyzing a beam with the same mass distribution along the x axis and identical stiffness in the x-z plane. This idealized, equivalent beam is shown in Figure 128.

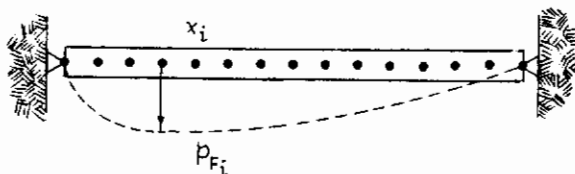

FIGURE 128 EQUIVALENT BEAM FOR FUEL TANK

In this analysis of the Fuel Tanks, structural items such as ring stiffeners, tank caps, plates, and fittings were considered concentrated masses. This consideration was incorporated in the computation of the point-mass matrix which appeared in the expression for kinetic energy. The kinetic energy was also expressed in terms of the generalized velocities, P_{F_i} , as;

$$T = \frac{1}{2} \{\dot{p}_F\}' [A_F] \{\dot{p}_F\} \quad (\text{II-21})$$

where $[A_F]$, the point-mass matrix, was expressed as;

$$[A_F] = \sum_{i=1}^M [T]_i' [A]_i [T]_i \quad (\text{II-22})$$

where $[A]_i$ was a function of the individual bay. This final point-mass matrix is presented in Table 28.

The strain energy stored in the equivalent beam was expressed in terms of the generalized loads, P_{F_i} , associated with the generalized coordinates.

$$U = \frac{1}{2} \{P_F\}^T [E_F] \{P_F\} \quad (II-23)$$

Where the collocation point influence coefficient matrix for the Fuel Tank, $[E_F]$, on two simple supports (as shown in Figure 128, was derived by first calculating an influence matrix for the beam cantilevered at $x = x_{15} = 350.717$. Using complementary strain energy principles these influence coefficients were transformed from cantilevered restraints to simply supported constraints. This transformation process was expressed in matrix form as;

$$[E_F] = [T]^T \left[\begin{array}{c} \text{cantilevered} \\ \text{influence} \\ \text{coefficients} \end{array} \right] [T] \quad (II-24)$$

The transformation matrix, $[T]$, was derived from equilibrium conditions on the loads and support reactions.

The mode shapes for the Fuel Tanks were determined through the iteration of the expression

$$[E_F] [A_F] \{\varphi\} = \lambda \{\varphi\} \quad (II-25)$$

It should be noted that the mode shapes for each of the four Fuel Tanks were identical, and that the mode shapes presented in Table 29 are for one tank. It should also be noted that these mode shapes were for the Fuel Tank on two simple supports.

2.7 Outrigger (R)

2.7.1 Degrees-of-Freedom for Outrigger

The assumptions that the Outrigger was rigid and limited to plane motion restricted the structure to three degrees-of-freedom (ξ_R , ζ_R , and θ_R) as shown in Figure 129. Also shown, for reference purposes, in Figure 129 are the displacements of the Outrigger center of mass (ξ and ζ).

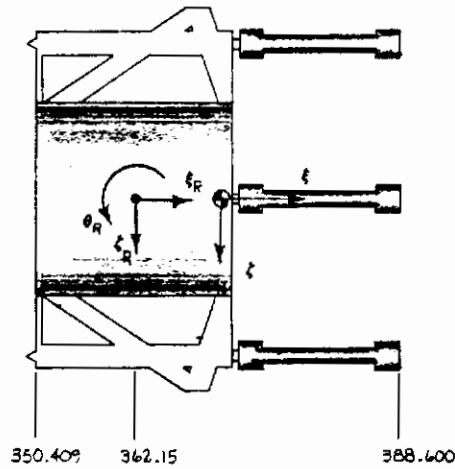

FIGURE 129 OUTRIGGER DEGREES-OF-FREEDOM

2.7.2 Outrigger Analysis

The analysis of the Outrigger was based on the assumption that this portion of the structure was a rigid body limited to plane motion. The kinetic energy of this body was expressed in terms of ξ and ζ (deflections of the center of mass) and θ (rotation of the body) as,

$$T = \frac{1}{2} M_R (\dot{\xi}^2 + \dot{\zeta}^2) + \frac{1}{2} I_R \dot{\theta}^2 \quad (\text{II-26})$$

Noting the relations,

$$\begin{aligned} \xi &= \xi_R - (\bar{x} - x_R) \theta_R \\ \zeta &= \zeta_R \\ \theta &= \theta_R \end{aligned} \quad (\text{II-27})$$

it was seen that,

$$\begin{aligned} \dot{\xi} &= \dot{\xi}_R - (\bar{x} - x_R) \dot{\theta}_R \\ \dot{\xi}^2 &= \dot{\xi}_R^2 - 2(\bar{x} - x_R) \dot{\theta}_R \dot{\xi}_R + (\bar{x} - x_R)^2 \dot{\theta}_R^2 \end{aligned} \quad (\text{II-28})$$

and that

$$\begin{aligned} \dot{\xi}^2 &= \dot{\xi}_R^2 \\ \dot{\theta}^2 &= \dot{\theta}_R^2 \end{aligned} \quad (\text{II-29})$$

Contrails

The combination of Equations II-26, II-27, II-28, and II-29 resulted in an expression for kinetic energy in terms of $\dot{\xi}_R$, $\dot{\zeta}_R$, and $\dot{\theta}_R$.

$$T = \frac{1}{2} M_R (\dot{\zeta}_R^2 - 2(\bar{x} - x_R) \dot{\theta}_R \dot{\zeta}_R + (\bar{x} - x_R)^2 \dot{\theta}_R^2 + \dot{\xi}_R^2) + \frac{1}{2} I_R \dot{\theta}_R^2 \quad (\text{II-30})$$

which was then expressed in matrix form as,

$$T = \frac{1}{2} \{ \dot{\xi}_R \quad \dot{\zeta}_R \quad \dot{\theta}_R \} \begin{bmatrix} M_R & 0 & 0 \\ 0 & M_R & -M_R(\bar{x} - x_R) \\ 0 & -M_R(\bar{x} - x_R) & I_R + M_R(\bar{x} - x_R)^2 \end{bmatrix} \begin{bmatrix} \dot{\xi}_R \\ \dot{\zeta}_R \\ \dot{\theta}_R \end{bmatrix} \quad (\text{II-31})$$

where

M_R was the total mass of the Outrigger (269.3 lb_m)

$I + M_R(\bar{x} - x_R)^2$ was the moment of inertia about point R (48641.5 lb_m-in²)

$-M_R(\bar{x} - x_R)$ was the first moment about point R (1901.0 lb_m-in).

Equation II-31 was then written in final matrix form as,

$$T = \frac{1}{2} \{ \dot{p}_R \}^T [A_R] \{ \dot{p}_R \} \quad (\text{II-32})$$

where

$$\{ \dot{p}_R \} = \begin{bmatrix} \dot{\xi}_R \\ \dot{\zeta}_R \\ \dot{\theta}_R \end{bmatrix} \quad (\text{II-33})$$

TABLE 22 UPPER STAGE (U) MASS, STIFFNESS, AND CANTILEVERED MODES

COLLOCATION POINT GEOMETRY
BAY LENGTH = 15.663 INCHES

COLLOCATION POINT	X-COORDINATE (INCHES FROM NOSE)
2	1.56630E 01
3	3.13260E 01
4	4.69890E 01
5	6.26520E 01
6	7.83160E 01
7	9.39780E 01
8	1.09641E 02
9	1.25306E 02

COLLOCATION POINT MASS MATRIX
(TOTAL MASS = 878.585 LBM)
(BALLAST TANK FILLED WITH WATER)

COLL. POINT	1	2	3	4	5	6	7	8	9
1	7.21085E-01	4.01681E-01	-1.09422E-01	4.21880E-03	0.				
2	4.01681E-01	2.44889E 00	-2.32715E 00	-1.93094E 00	2.04888E-01				
3	-1.09422E-01	-2.32716E 00	3.90913E 01	1.10699E 01	-6.48231E 00	4.51175E-01	0.	0.	0.
4	4.21880E-03	-1.93094E 00	1.10699E 01	1.25876E 02	3.71403E 01	-9.03493E 00	4.52318E-01	0.	0.
5	0.	2.04888E-01	-6.48231E 00	3.71398E 01	2.05569E 02	3.23490E 01	-8.90868E 00	4.38550E-01	0.
6	0.	0.	4.51175E-01	-9.03493E 00	3.23485E 01	2.02561E 02	3.74641E 01	-4.59528E 00	2.09784E-02
7	0.	0.	0.	4.52318E-01	-8.90868E 00	3.74636E 01	1.04832E 02	-5.71526E 00	-5.07044E-01
8	0.	0.	0.	0.	4.38550E-01	-4.59528E 00	-5.71529E 00	2.87263E 01	2.36271E 00
9						2.09784E-02	-5.07044E-01	2.36271E 00	2.26441E 00

COLLOCATION POINT
STRUCTURAL INFLUENCE COEFFICIENTS MATRIX

COLL. POINT	1	2	3	4	5	6	7	8	9
1	2.52041E-04	1.53918E-04	1.03819E-04	6.69653E-05	3.74016E-05	1.61452E-05	5.58735E-06	1.59701E-06	0.
2	1.53918E-04	1.21666E-04	8.55629E-05	5.64261E-05	3.22428E-05	1.42898E-05	5.04918E-06	1.49176E-06	0.
3	1.03819E-04	8.55629E-05	6.73064E-05	4.58868E-05	2.70839E-05	1.24344E-05	4.51100E-06	1.38651E-06	0.
4	6.69653E-05	5.64261E-05	4.58868E-05	3.53476E-05	2.19250E-05	1.05789E-05	3.97282E-06	1.28126E-06	0.
5	3.74016E-05	3.22428E-05	2.70839E-05	2.19250E-05	1.67662E-05	8.72351E-06	3.43465E-06	1.17601E-06	0.
6	1.61452E-05	1.42898E-05	1.24344E-05	1.05789E-05	8.72351E-06	6.86796E-06	2.89644E-06	1.07076E-06	0.
7	5.58735E-06	5.04918E-06	4.51100E-06	3.97282E-06	3.43465E-06	2.89644E-06	2.35829E-06	9.65514E-07	0.
8	1.59701E-06	1.49176E-06	1.38651E-06	1.28126E-06	1.17601E-06	1.07076E-06	9.65514E-07	8.60264E-07	0.

MODAL DATA

CANTILEVERED AT X = 125.306

COLL. POINT	1ST MODE 27.28 CPS	2ND MODE 89.04 CPS	3RD MODE 174.16 CPS	4TH MODE 273.08 CPS
1	9.6424360E-02	1.6796861E-01	2.4422816E-01	5.4789109E-01
2	8.1195670E-02	1.1838275E-01	1.4369598E-01	2.1827023E-01
3	6.6316996E-02	7.4647183E-02	7.3377694E-02	4.1197221E-02
4	5.0869723E-02	2.5571569E-02	-7.8173396E-03	-5.2769397E-02
5	3.4241724E-02	-2.3343700E-02	-3.8395116E-02	3.2723531E-02
6	1.7834081E-02	-4.1927207E-02	3.3220338E-02	6.1911686E-04
7	6.9849456E-03	-2.3426839E-02	3.2963625E-02	-3.1780140E-02
8	2.3468201E-03	-9.8140919E-03	1.4239716E-02	-1.5388012E-02

TABLE 23
MIDDLE STAGE (M) MASS MATRIX

COLLOCATION POINT GEOMETRY

RAY LENGTH = 4.7181 INCHES

COLLOCATION POINT X-COORDINATE (INCHES FROM NOSE)

1	1.17266E 02
2	1.23984E 02
3	1.30702E 02
4	1.37420E 02
5	1.44138E 02
6	1.50857E 02
7	1.57575E 02
8	1.64293E 02
9	1.71011E 02
10	1.77729E 02
11	1.84447E 02
12	1.91165E 02
13	1.97883E 02
14	2.04601E 02
15	2.11319E 02

COLLOCATION POINT MASS MATRIX
(TOTAL MASS = 830.854 LBM)
(BALLAST TANK FILLED WITH WATER)

COLL. POINT	1	2	3	4	5	6	7	8	9	10	11	12	13	14	15
1	5.17612E 00	1.06641E 00	-2.19920E 00	1.67619E-01	0.										
2	1.06641E 00	5.56256E 01	1.38969E 01	-3.35174E 00	1.64436E-01										
3	-2.19920E 00	1.38969E 01	7.45087E 01	1.17763E 01	-3.28889E 00	1.64322E-01	0.	0.	0.	0.					
4	1.67619E-01	-3.35174E 00	1.17761E 01	7.72990E 01	1.15798E 01	-3.34947E 00	1.70051E-01	0.	0.	0.					
5	0.	1.64436E-01	-3.28889E 00	1.15794E 01	7.51437E 01	1.22449E 01	-3.33891E 00	1.64322E-01	0.	0.					
6	0.	0.	1.64322E-01	-3.34947E 00	1.22443E 01	7.65298E 01	1.13615E 01	-3.38213E 00	1.74947E-01	0.					
7	0.	0.	0.	1.70051E-01	-3.33891E 00	1.13613E 01	7.66385E 01	1.26013E 01	-3.38992E 00	1.64322E-01					
8	0.	0.	0.	0.	1.64322E-01	-3.38213E 00	1.26011E 01	7.55561E 01	1.17211E 01	-3.14341E 00	1.49930E-01	0.	0.	0.	0.
9							1.74947E-01	-3.38992E 00	1.17209E 01	7.28529E 01	1.24562E 01	-1.67997E 00	1.65857E-02	0.	0.
10							0.	1.64322E-01	-3.16341E 00	1.24560E 01	4.02563E 01	-4.68888E-01	2.83162E-02	0.	0.
11							0.	0.	1.49930E-01	-1.67997E 00	-7.40700E-01	9.54102E 00	2.07331E 00	-4.16789E-01	1.45754E-02
12							0.	0.	0.	1.65857E-02	-4.96888E-01	2.07330E 00	7.70715E 00	8.32278E-01	-3.90430E-01
13							0.	0.	0.	2.83162E-02	2.83162E-02	-4.16789E-01	8.32273E-01	7.79359E 00	1.67195E 00
14												1.45754E-02	-3.90430E-01	1.67195E 00	2.10993E 01
15												0.	2.10371E-02	-3.24670E-01	7.39170E-01

TABLE 24
MIDDLE STAGE (M) INFLUENCE COEFFICIENTS AND MODES CANTILEVERED WITH RIGID ADAPTER

MODAL DATA

CANTILEVERED AT X = 211.320 WITH RIGID ADAPTER

COLL. POINT	1ST MODE 77.67 CPS	2ND MODE 293.91 CPS	3RD MODE 589.32 CPS	4TH MODE 833.75 CPS
1	6.1469032E-02	7.0145206E-02	1.0011874E-01	1.4616761E-01
2	5.6099150E-02	5.2539498E-02	5.9099817E-02	4.4627587E-02
3	5.0196491E-02	2.9211656E-02	2.5788112E-03	-3.4328517E-02
4	4.4335312E-02	8.4282113E-03	-2.9414154E-02	-4.2202427E-02
5	3.8179188E-02	-1.2451923E-02	-4.3825732E-02	-6.3034716E-03
6	3.1864063E-02	-3.0303756E-02	-3.3774938E-02	3.5826434E-02
7	2.5544200E-02	-4.2428946E-02	-4.3919004E-03	4.2431056E-02
8	1.9398544E-02	-4.6985331E-02	2.8230114E-02	6.5749019E-03
9	1.3625416E-02	-4.3484290E-02	4.6791493E-02	-3.4262214E-02
10	8.4403805E-03	-3.2896985E-02	4.1828706E-02	-4.4196014E-02
11	4.0904049E-03	-1.8891596E-02	2.4340488E-02	-2.4967304E-02
12	8.0018141E-04	-4.5171423E-03	5.8858390E-03	-6.7650599E-03
13	9.1121145E-12	-1.6028087E-11	2.34669644E-11	-2.2517131E-11
14	2.3429913E-12	-5.0224105E-12	6.5879564E-12	-6.4039018E-12

COLLOCATION POINT
STRUCTURAL INFLUENCE COEFFICIENTS MATRIX

COLL. POINT	1	2	3	4	5	6	7	8	9	10	11	12	13	14	15
1	6.32242E-06	6.13398E-06	5.15192E-06	4.36980E-06	3.61613E-06	2.90114E-06	2.23574E-06	1.63095E-06	1.09826E-06	6.49558E-07	2.97023E-07	5.31286E-08	8.09995E-16	2.07920E-16	0.
2	6.13398E-06	5.97422E-06	4.69497E-06	4.00337E-06	3.33074E-06	2.68712E-06	2.08319E-06	1.52978E-06	1.03818E-06	6.20045E-07	2.87412E-07	5.29585E-08	7.49348E-16	1.92755E-16	0.
3	5.15192E-06	4.69497E-06	4.23802E-06	3.63693E-06	3.04536E-06	2.47310E-06	1.93064E-06	1.42860E-06	9.78077E-07	5.90531E-07	2.77800E-07	5.19884E-08	6.88700E-16	1.77591E-16	0.
4	4.36980E-06	4.00337E-06	3.63693E-06	3.27050E-06	2.75997E-06	2.25909E-06	1.77809E-06	1.32743E-06	9.17978E-07	5.61017E-07	2.48189E-07	5.14183E-08	6.28052E-16	1.62427E-16	0.
5	3.61613E-06	3.33074E-06	3.04536E-06	2.75997E-06	2.47458E-06	2.04507E-06	1.62254E-06	1.22623E-06	8.57878E-07	5.31504E-07	2.58578E-07	5.08482E-08	5.67404E-16	1.47263E-16	0.
6	2.90114E-06	2.68712E-06	2.47310E-06	2.25909E-06	2.04507E-06	1.83102E-06	1.47297E-06	1.12506E-06	7.97770E-07	5.01986E-07	2.48965E-07	5.02780E-08	5.06748E-16	1.32094E-16	0.
7	2.23574E-06	2.08319E-06	1.93064E-06	1.77809E-06	1.62254E-06	1.47297E-06	1.32043E-06	1.02388E-06	7.37671E-07	4.72472E-07	2.39353E-07	4.97080E-08	4.46100E-16	1.16932E-16	0.
8	1.63095E-06	1.52978E-06	1.42860E-06	1.32743E-06	1.22623E-06	1.12506E-06	1.02388E-06	9.22709E-07	6.77571E-07	4.42958E-07	2.9742E-07	4.91379E-08	3.85452E-16	1.01768E-16	0.
9	1.09826E-06	1.03818E-06	9.78077E-07	9.17978E-07	8.57878E-07	7.97770E-07	7.37671E-07	6.77571E-07	6.17472E-07	4.13444E-07	2.20130E-07	4.85678E-08	3.244804E-16	8.66038E-17	0.
10	6.49558E-07	6.20045E-07	5.90531E-07	5.61017E-07	5.31504E-07	5.01986E-07	4.72472E-07	4.42958E-07	4.13444E-07	3.83931E-07	1.0519E-07	4.79977E-08	2.64157E-16	7.14396E-17	0.
11	2.97023E-07	2.87412E-07	2.77800E-07	2.68189E-07	2.58578E-07	2.48965E-07	2.39353E-07	2.29742E-07	2.20130E-07	2.10519E-07	2.00908E-07	4.74276E-08	2.03509E-16	5.62754E-17	0.
12	5.31286E-08	5.25985E-08	5.19884E-08	5.08482E-08	5.02780E-08	5.02780E-08	4.97080E-08	4.91379E-08	4.85678E-08	4.79977E-08	4.74276E-08	4.68375E-08	1.42861E-16	4.11112E-17	0.
13	8.09995E-16	7.49348E-16	6.88700E-16	6.28052E-16	5.67404E-16	5.06748E-16	4.46100E-16	3.85452E-16	3.244804E-16	2.64157E-16	2.03509E-16	1.42861E-16	8.22134E-17	2.59471E-17	0.
14	2.07920E-16	1.92755E-16	1.77591E-16	1.62427E-16	1.47263E-16	1.32094E-16	1.16932E-16	1.01768E-16	8.66038E-17	7.14396E-17	5.62754E-17	4.11112E-17	2.59471E-17	1.07829E-17	0.

TABLE 25
SPIDER BEAM (S) COLLOCATION POINT STRUCTURAL INFLUENCE COEFFICIENTS MATRIX

COLL. POINT	1	2	3	4	5	6	7	8
1	4.0956465E-05	6.6007798E-06	5.7130059E-06	4.8252400E-06	4.4368825E-06	4.8252400E-06	5.7130059E-06	6.6007798E-06
2	6.6007798E-06	4.0956465E-05	6.6007798E-06	5.7130059E-06	4.8252400E-06	4.4368825E-06	4.8252400E-06	5.7130059E-06
3	5.7130059E-06	6.6007798E-06	4.0956465E-05	6.6007798E-06	5.7130059E-06	4.8252400E-06	4.4368825E-06	4.8252400E-06
4	4.8252400E-06	5.7130059E-06	6.6007798E-06	4.0956465E-05	6.6007798E-06	5.7130059E-06	4.8252400E-06	4.4368825E-06
5	4.4368825E-06	4.8252400E-06	5.7130059E-06	6.6007798E-06	4.0956465E-05	6.6007798E-06	5.7130059E-06	4.8252400E-06
6	4.8252400E-06	4.4368825E-06	4.8252400E-06	5.7130059E-06	6.6007798E-06	4.0956465E-05	6.6007798E-06	5.7130059E-06
7	5.7130059E-06	4.8252400E-06	4.4368825E-06	4.8252400E-06	5.7130059E-06	6.6007798E-06	4.0956465E-05	6.6007798E-06
8	6.6007798E-06	5.7130059E-06	4.8252400E-06	4.4368825E-06	4.8252400E-06	5.7130059E-06	6.6007798E-06	4.0956465E-05
9								
10								
11								

TABLE 26
CENTER LOX TANK (L) MASS MATRIX

COLLOCATION POINT GEOMETRY
BAY LENGTH = 9.691 INCHES
X-COORDINATE
(INCHES FROM NOSE)

COLLOCATION POINT	X-COORDINATE (INCHES FROM NOSE)
1	2.14732E 02
2	2.24423E 02
3	2.34114E 02
4	2.43806E 02
5	2.53497E 02
6	2.63188E 02
7	2.72879E 02
8	2.82570E 02
9	2.92262E 02
10	3.01953E 02
11	3.11644E 02
12	3.21335E 02
13	3.31026E 02
14	3.40718E 02
15	3.50409E 02

COLLOCATION POINT MASS MATRIX
TOTAL MASS (EMPTY) = 61.970 LBM

COLL. POINT	1	2	3	4	5	6	7	8	9	10	11	12	13	14	15
1	2.95699E 00	1.01032E 00	-2.47623E-01	7.53428E-03	-0.										
2	1.01032E 00	7.04016E 00	5.75558E-01	-1.31911E-01	4.55137E-03										
3	-2.47623E-01	5.75558E-01	2.49135E 00	2.95767E-01	-9.10273E-02	4.55137E-03	0.	0.	0.	0.					
4	7.53428E-03	-1.31911E-01	2.95767E-01	2.07776E 00	3.23155E-01	-9.10273E-02	4.55137E-03	0.	0.	0.					
5		4.55137E-03	-9.10273E-02	3.23155E-01	2.07544E 00	-2.23155E-01	-9.10273E-02	4.55137E-03	0.	0.					
6		0.	4.55137E-03	-9.10273E-02	3.23155E-01	0.07544E 00	3.23155E-01	-9.10273E-02	4.55137E-03	0.					
7		0.	0.	4.55137E-03	-9.10273E-02	3.23155E-01	2.07544E 00	3.23155E-01	-9.10273E-02	4.55137E-03					
8		0.	0.	0.	4.55137E-03	-9.10273E-02	3.23155E-01	2.07544E 00	3.23155E-01	-9.10273E-02	4.55137E-03				
9															
10															
11															
12															
13															
14															
15															

TABLE 27
CENTER LOX TANK (L) CANTILEVERED INFLUENCE COEFFICIENTS AND MODES

MODAL DATA

CANTILEVERED AT X = 350.409

COLL. POINT	1ST MODE 35.84 CPS	2ND MODE 202.81 CPS	3RD MODE 414.47 CPS	4TH MODE 653.90 CPS
1	2.4654423E-01	-1.5998072E-01	1.1852918E-01	1.2972127E-01
2	2.2224364E-01	-9.0046691E-02	4.6308881E-02	2.9839332E-02
3	1.9758494E-01	-1.4888576E-02	-3.8541665E-02	-9.3330902E-02
4	1.7285050E-01	5.9339920E-02	-1.1400653E-01	-1.8841480E-01
5	1.4857087E-01	1.2417300E-01	-1.6409007E-01	-2.0334435E-01
6	1.2505036E-01	1.7532994E-01	-1.7464052E-01	-1.3737036E-01
7	1.0262764E-01	2.0953250E-01	-1.4471658E-01	-1.7538828E-02
8	8.1605484E-02	2.2492085E-01	-8.6946350E-02	1.1088533E-01
9	6.2543984E-02	2.2130988E-01	-8.2716377E-03	1.9915299E-01
10	4.5499371E-02	2.0056513E-01	7.1452409E-02	2.1267576E-01
11	3.1341342E-02	1.6879194E-01	1.3271044E-01	1.3294035E-01
12	1.9427375E-02	1.2903374E-01	1.6932091E-01	4.2107432E-02
13	1.0326444E-02	8.7210849E-02	1.7411621E-01	-7.8188702E-02
14	3.9029669E-03	4.9702739E-02	1.6793764E-01	-1.3836220E-01

COLLOCATION POINT
STRUCTURAL INFLUENCE COEFFICIENTS MATRIX

COLL. POINT	1	2	3	4	5	6	7	8	9	10	11	12	13	14
1	4.70434E-04	4.20556E-04	3.70211E-04	3.20389E-04	2.72333E-04	2.26624E-04	1.83950E-04	1.44597E-04	1.09449E-04	7.90481E-05	5.35103E-05	3.26610E-05	1.70067E-05	6.11284E-06
2	4.20556E-04	3.78021E-04	3.34277E-04	2.90530E-04	2.47961E-04	2.07153E-04	1.66692E-04	1.33166E-04	1.01156E-04	7.33125E-05	4.98208E-05	3.05487E-05	1.60039E-05	5.84048E-06
3	3.70211E-04	3.34277E-04	2.98344E-04	2.60671E-04	2.23590E-04	1.87482E-04	1.53535E-04	1.21736E-04	9.28679E-05	6.75769E-05	4.61313E-05	2.84364E-05	1.50002E-05	5.56813E-06
4	3.20389E-04	2.90530E-04	2.60671E-04	2.30810E-04	1.99216E-04	1.68209E-04	1.38376E-04	1.10304E-04	8.45766E-05	6.18407E-05	4.24414E-05	2.63238E-05	1.39969E-05	5.29575E-06
5	2.72333E-04	2.47961E-04	2.23590E-04	1.99216E-04	1.74845E-04	1.48738E-04	1.23219E-04	9.88734E-05	7.62862E-05	5.61051E-05	3.87518E-05	2.42115E-05	1.29937E-05	5.02339E-06
6	2.26624E-04	2.07153E-04	1.87482E-04	1.68209E-04	1.48738E-04	1.29267E-04	1.08062E-04	8.74429E-05	6.79959E-05	5.03696E-05	3.50623E-05	2.20902E-05	1.19004E-05	4.75104E-06
7	1.83950E-04	1.68692E-04	1.53535E-04	1.38376E-04	1.23219E-04	1.08062E-04	9.29045E-05	7.60124E-05	5.97055E-05	4.46340E-05	3.13727E-05	1.99869E-05	1.09872E-05	4.47869E-06
8	1.44597E-04	1.33166E-04	1.21736E-04	1.10304E-04	9.88734E-05	8.74429E-05	7.60124E-05	6.45818E-05	5.14151E-05	3.88984E-05	2.76832E-05	1.78746E-05	9.98399E-06	4.20633E-06
9	1.09449E-04	1.01156E-04	9.28679E-05	8.45766E-05	7.62862E-05	6.79959E-05	5.97055E-05	5.14151E-05	4.31239E-05	3.31622E-05	2.39933E-05	1.57620E-05	8.98065E-06	3.93395E-06
10	7.90481E-05	7.33125E-05	6.75769E-05	6.18407E-05	5.61051E-05	5.03696E-05	4.46340E-05	3.88984E-05	3.31622E-05	2.74266E-05	2.03037E-05	1.36497E-05	7.97742E-06	3.66160E-06
11	5.35103E-05	4.98208E-05	4.61313E-05	4.24414E-05	3.87518E-05	3.50623E-05	3.13727E-05	2.76832E-05	2.39933E-05	2.03037E-05	1.66142E-05	1.15374E-05	6.97419E-06	3.38924E-06
12	3.26610E-05	3.05487E-05	2.84364E-05	2.63238E-05	2.42115E-05	2.20992E-05	1.99869E-05	1.78746E-05	1.57620E-05	1.36497E-05	1.15374E-05	9.42506E-06	5.97097E-06	3.11689E-06
13	1.70067E-05	1.60039E-05	1.50002E-05	1.39969E-05	1.29937E-05	1.19904E-05	1.09872E-05	9.98399E-06	8.98065E-06	7.97742E-06	6.97419E-06	5.97097E-06	4.96774E-06	2.84454E-06
14	6.11284E-06	5.84048E-06	5.56813E-06	5.29575E-06	5.02339E-06	4.75104E-06	4.47869E-06	4.20633E-06	3.93395E-06	3.66160E-06	3.38924E-06	3.11689E-06	2.84454E-06	2.57216E-06

TABLE 28
FUEL TANKS (F) MASS MATRIX

COLLOCATION POINT GEOMETRY
BAY LENGTH = 9.6271 INCHES
X-COORDINATE
(INCHES FROM MDSE)

COLLOCATION POINT	X-COORDINATE (INCHES FROM MDSE)
1	2.19937E 02
2	2.25564E 02
3	2.35191E 02
4	2.44818E 02
5	2.54445E 02
6	2.64073E 02
7	2.73700E 02
8	2.83327E 02
9	2.92954E 02
10	3.02581E 02
11	3.12208E 02
12	3.21835E 02
13	3.31462E 02
14	3.41089E 02
15	3.50717E 02

COLLOCATION POINT MASS MATRIX
TOTAL MASS (EMPTY) = 14.901 LBM

COLL. POINT	1	2	3	4	5	6	7	8	9	10	11	12	13	14	15
1	5.62410E-01	0.57369E-02	-4.70323E-02	2.05970E-03	-0.										
2	0.57369E-02	1.98081E 00	2.40492E-01	-3.46394E-02	8.25173E-04										
3	-4.70323E-02	2.40491E-01	4.90310E-01	5.05774E-02	-1.65035E-02	8.25173E-04	0.	0.	0.	0.					
4	2.05970E-03	-3.46394E-02	5.05764E-02	3.76964E-01	5.85888E-02	-1.65035E-02	8.25173E-04	0.	0.	0.					
5	0.	8.25173E-04	-1.65035E-02	3.76394E-01	5.72709E-02	-1.73447E-02	9.09298E-04	0.	0.	0.					
6	0.	0.	8.25173E-04	-1.65035E-02	5.72700E-02	3.95465E-01	6.58511E-02	-1.82043E-02	9.11129E-04	0.					
7	0.	0.	0.	8.25173E-04	-1.73447E-02	6.58501E-02	4.14949E-01	6.47205E-02	-1.82226E-02	9.11129E-04					
8	0.	0.	0.	0.	9.09298E-04	-0.82043E-02	6.47195E-02	4.15520E-01	6.41768E-02	-1.85513E-02	9.44005E-04	0.	0.	0.	0.
9						9.11129E-04	-1.82226E-02	6.41758E-02	4.23022E-01	6.69789E-02	-0.92390E-02	9.79893E-04	0.	0.	0.
10						0.	9.11129E-04	-1.85513E-02	6.69778E-02	4.38660E-01	7.01365E-02	-1.95979E-02	9.79893E-04	0.	0.
11						0.	0.	9.44005E-04	-1.92390E-02	7.01354E-02	4.46787E-01	6.95742E-02	-1.95979E-02	9.79893E-04	0.
12						0.	0.	0.	9.79893E-04	-1.95979E-02	6.95731E-02	4.59059E-01	-1.11111E-02	-8.87671E-02	8.45094E-03
13						0.	0.	0.	0.	9.79893E-04	-1.11122E-02	1.33743E 00	5.93459E-01	-1.60504E-01	5.87753E-01
14											9.79893E-04	-8.87671E-02	5.93456E-01	2.61877E 00	5.87753E-01
15												8.45094E-03	-1.60504E-01	5.87753E-01	1.15046E 00

TABLE 29
FUEL TANKS (F) SIMPLY SUPPORTED INFLUENCE COEFFICIENTS AND MODES

COLLOCATION POINT
 STRUCTURAL INFLUENCE COEFFICIENTS MATRIX

COLL. POINT	1	2	3	4	5	6	7	8	9	10	11	12	13	14	15
1															
2	3.02859E-05	5.17552E-05	6.74723E-05	7.76563E-05	8.28104E-05	8.36678E-05	8.08368E-05	7.47774E-05	6.59943E-05	5.50849E-05	4.24703E-05	2.85783E-05	1.42663E-05	2.96558E-12	
3	5.17551E-05	1.01386E-04	1.32998E-04	1.53543E-04	1.64028E-04	1.65920E-04	1.60435E-04	1.48493E-04	1.31108E-04	.09462E-04	8.44096E-05	5.68025E-05	2.83555E-05	5.89423E-12	
4	6.74723E-05	1.32998E-04	1.90024E-04	2.21702E-04	2.38291E-04	2.41990E-04	2.34624E-04	2.17572E-04	1.92355E-04	1.60749E-04	1.24031E-04	8.34814E-05	4.16721E-05	8.66169E-12	
5	7.76563E-05	1.53543E-04	2.21702E-04	2.74771E-04	2.98974E-04	3.05988E-04	2.98249E-04	2.77597E-04	2.46058E-04	2.05998E-04	1.59125E-04	1.07142E-04	5.34794E-05	1.11143E-11	
6	8.28105E-05	1.64028E-04	2.38291E-04	2.98974E-04	3.41551E-04	3.53894E-04	3.47795E-04	3.25554E-04	2.89704E-04	2.43203E-04	1.88189E-04	1.26780E-04	6.32754E-05	1.31474E-11	
7	8.36678E-05	1.65920E-04	2.41990E-04	2.98974E-04	3.05988E-04	3.53894E-04	3.82068E-04	3.60075E-04	3.21017E-04	2.70541E-04	2.09845E-04	1.41485E-04	7.06044E-05	1.46659E-11	
8	8.08368E-05	1.60435E-04	2.34624E-04	2.98974E-04	3.47795E-04	3.53894E-04	3.82068E-04	3.80075E-04	3.47795E-04	3.39487E-04	2.86804E-04	2.23199E-04	1.50652E-04	7.51640E-05	1.56068E-11
9	7.47774E-05	1.48493E-04	2.17572E-04	2.74771E-04	2.98974E-04	3.25554E-04	3.58711E-04	3.75257E-04	3.72433E-04	3.39814E-04	2.90154E-04	2.26868E-04	1.53362E-04	7.64960E-05	1.58742E-11
10	6.59943E-05	1.31108E-04	1.92355E-04	2.46058E-04	2.89704E-04	2.89704E-04	3.21017E-04	3.39487E-04	3.39814E-04	3.22750E-04	2.78791E-04	2.19501E-04	1.48715E-04	7.41489E-05	1.53743E-11
11	5.50849E-05	1.09462E-04	1.60749E-04	1.60749E-04	2.05998E-04	2.43203E-04	2.70541E-04	2.70541E-04	2.90154E-04	2.78791E-04	2.51833E-04	2.00439E-04	1.36271E-04	6.79028E-05	1.40610E-11
12	4.24703E-05	8.44096E-05	1.24031E-04	1.59125E-04	1.88189E-04	1.88189E-04	2.09845E-04	2.23199E-04	2.26868E-04	2.19501E-04	2.00439E-04	1.68602E-04	1.15310E-04	5.73982E-05	1.18595E-11
13	2.85783E-05	5.68025E-05	8.34814E-05	1.07142E-04	1.26780E-04	1.26780E-04	1.41485E-04	1.50652E-04	1.53362E-04	1.48715E-04	1.36271E-04	1.15310E-04	8.49808E-05	4.22093E-05	8.68075E-12
14	1.42663E-05	2.83555E-05	4.16721E-05	5.34794E-05	6.32754E-05	7.06044E-05	7.51640E-05	7.51640E-05	7.64960E-05	7.41489E-05	6.79028E-05	5.73982E-05	4.22093E-05	2.25777E-05	4.57530E-12
15	2.96558E-12	5.89423E-12	8.66169E-12	1.11143E-11	.31474E-11	1.46659E-11	1.56068E-11	1.58742E-11	1.53743E-11	1.40610E-11	1.18595E-11	8.68075E-12	4.57530E-12	9.93179E-19	

MODAL DATA

SIMPLY SUPPORTED AT EACH END			
COLL. POINT	1ST MODE	2ND MODE	3RD MODE
	80.73 CPS	274.45 CPS	509.16 CPS
1			
2	1.1128924E-01	2.1123383E-01	-2.8856620E-01
3	2.1915043E-01	3.8064257E-01	-4.1482159E-01
4	3.1693343E-01	4.7489748E-01	-3.3832310E-01
5	3.9751486E-01	4.7493008E-01	-1.1547024E-01
6	4.5674300E-01	3.8995401E-01	1.8463001E-01
7	4.9203560E-01	2.34660719E-01	3.8922325E-01
8	5.0270422E-01	4.5772703E-02	4.8509100E-01
9	4.8795750E-01	-1.44895144E-01	4.1937048E-01
10	4.4641456E-01	-3.0324633E-01	2.2102042E-01
11	3.8692824E-01	-3.9514789E-01	-2.9146634E-02
12	3.0607492E-01	-4.0396473E-01	-2.3643684E-01
13	2.0929793E-01	-3.2385424E-01	-3.1712634E-01
14	1.0473522E-01	-1.6718564E-01	-1.8159000E-01
15	2.1689985E-08	-3.3606349E-08	-3.4684613E-08

TABLE 30 BENDING AND SHEAR RIGIDITY OF BEAM-LIKE COMPONENTS

EI SLICE DATA				GA SLICE DATA			
SLICE BOUNDARIES		SLICE VALUE(S)		SLICE BOUNDARIES		SLICE VALUE(S)	
X-COORDINATE	X-COORDINATE	EI VALUE	EI VALUE	X-COORDINATE	X-COORDINATE	GA VALUE	GA VALUE
UPPER STAGE				UPPER STAGE			
0.	2.500000E 00	1.000000E 05	1.500000E 06	0.	2.500000E 00	3.500000E 05	1.000000E 06
2.500000E 00	5.000000E 00	1.500000E 06	6.500000E 06	2.500000E 00	5.000000E 00	1.000000E 06	1.150000E 06
5.000000E 00	2.000000E 01	6.500000E 06	2.500000E 08	5.000000E 00	2.000000E 01	1.150000E 06	2.500000E 06
7.000000E 01	3.000000E 01	2.500000E 08	6.250000E 08	2.000000E 01	3.000000E 01	2.500000E 06	3.400000E 06
3.000000E 01	3.600000E 01	6.250000E 08	1.000000E 09	3.000000E 01	3.600000E 01	3.400000E 06	4.000000E 06
3.600000E 01	4.400000E 01	1.000000E 09	1.850000E 09	3.600000E 01	4.400000E 01	4.000000E 06	4.850000E 06
4.400000E 01	8.800000E 01	1.850000E 09	1.850000E 09	4.400000E 01	8.800000E 01	4.850000E 06	4.850000E 06
8.800000E 01	1.000000E 02	4.050000E 09	8.000000E 09	8.800000E 01	1.000000E 02	1.455000E 07	1.660000E 07
1.000000E 02	1.070000E 02	8.000000E 09	1.085000E 10	1.000000E 02	1.070000E 02	1.660000E 07	1.775000E 07
1.070000E 02	1.110000E 02	1.085000E 10	1.300000E 10	1.070000E 02	1.110000E 02	1.775000E 07	1.845000E 07
1.110000E 02	1.170000E 02	1.300000E 10	1.650000E 10	1.110000E 02	1.170000E 02	1.845000E 07	1.945000E 07
1.170000E 02	1.253060E 02	1.650000E 10	2.200000E 10	1.170000E 02	1.253060E 02	1.945000E 07	2.185000E 07
MIDDLE STAGE				MIDDLE STAGE			
1.172660E 02	1.212880E 02	9.7399999E 08	1.0326837E 09	1.172660E 02	1.212880E 02	3.3100000E 06	5.3583003E 06
1.212880E 02	1.253090E 02	1.0326837E 09	1.9479450E 09	1.212880E 02	1.253090E 02	5.3583003E 06	6.6205924E 06
1.253090E 02	1.423100E 02	3.3324611E 10	3.1474882E 10	1.253090E 02	1.423100E 02	4.6110508E 07	4.6110508E 07
1.423100E 02	1.593130E 02	3.1474882E 10	2.9856592E 10	1.423100E 02	1.593130E 02	4.6110508E 07	4.6110508E 07
1.593130E 02	1.763170E 02	2.9856592E 10	2.8469738E 10	1.593130E 02	1.763170E 02	4.6110508E 07	4.6110508E 07
1.763170E 02	1.933200E 02	2.8469738E 10	2.7314321E 10	1.763170E 02	1.933200E 02	4.6110508E 07	4.6110508E 07
1.933200E 02	2.113200E 02	9.9999998E 18	9.9999998E 18	1.933200E 02	2.113200E 02	9.9999998E 18	9.9999998E 18
CENTER LOX TANK				CENTER LOX TANK			
2.147320E 02	2.252920E 02	4.1438364E 09	4.1438364E 09	2.147320E 02	2.252920E 02	1.9837592E 07	1.9837592E 07
2.252920E 02	2.316020E 02	2.4505693E 09	2.4505693E 09	2.252920E 02	2.316020E 02	8.3375920E 06	8.3375920E 06
2.316020E 02	3.002320E 02	1.5508256E 09	1.5508256E 09	2.316020E 02	3.002320E 02	5.2879286E 06	5.2879286E 06
3.002320E 02	3.301120E 02	1.9412973E 09	1.9412973E 09	3.002320E 02	3.301120E 02	6.6130525E 06	6.6130525E 06
3.301120E 02	3.393620E 02	2.9223334E 09	2.9223334E 09	3.301120E 02	3.393620E 02	9.9313594E 06	9.9313594E 06
3.393620E 02	3.504090E 02	1.6708698E 09	1.6708698E 09	3.393620E 02	3.504090E 02	4.0538160E 06	4.0538160E 06
FUEL TANKS				FUEL TANKS			
2.159370E 02	2.310770E 02	1.7618052E 06	1.7618052E 06	2.159370E 02	2.310770E 02	2.2942403E 08	2.2942403E 08
2.310770E 02	2.642770E 02	9.7030599E 05	9.7030599E 05	2.310770E 02	2.642770E 02	1.2669718E 08	1.2669718E 08
2.642770E 02	2.9797699E 02	1.0584402E 06	1.0584402E 06	2.642770E 02	2.9797699E 02	1.3818558E 08	1.3818558E 08
2.9797699E 02	3.316770E 02	1.1465619E 06	1.1465619E 06	2.9797699E 02	3.316770E 02	1.4966905E 08	1.4966905E 08
3.316770E 02	3.380670E 02	1.7618052E 06	1.7618052E 06	3.316770E 02	3.380670E 02	2.2942403E 08	2.2942403E 08
3.380670E 02	3.507170E 02	9.8834051E 06	9.8834051E 06	3.380670E 02	3.507170E 02	5.3016940E 08	5.3016940E 08

3.0 COUPLING OF SATURN MODEL COMPONENT MODES

3.1 Introduction

The ultimate goal of this analysis of the Saturn Model was to determine the mode shapes and natural frequencies of the 1/5 scale model. The basic idea behind breaking the model down into component structures was the reduction of the number of degrees-of-freedom used in the final coupling process. It can be seen that the component structures of the model have been allowed a total of 251 degrees-of-freedom. The manipulation of matrices of this size would be very difficult not only in computation, but also in the mere analytical expressions preceding the computation. It will be seen here that this number of degrees-of-freedom can be reduced to 24 through the use of component modes as generalized coordinates.

3.2 Vehicle Without Outer Lox Tanks

For the purpose of this final coupling analysis, an intermediate vehicle configuration was defined and analyzed through the use of its component structures modes. This intermediate configuration was defined as the "Center Lox Tank Vehicle" and consisted of the entire Saturn Model with only the Outer Lox Tanks removed. This configuration was selected because it essentially eliminated all major redundant load paths. Physically, this allowed any component structure to store strain energy without forcing adjacent structures to also store strain energy. (If the Outer Lox Tanks had been left in, then strain energy in one tank would have forced strain energy into the Spider Beam, Center Lox Tank, and other outer Lox Tanks.) Analytically, this selection of configuration allowed a much simpler intermediate coupling analysis.

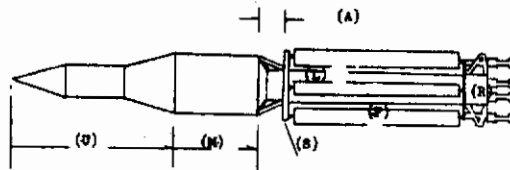

FIGURE 130 VEHICLE WITHOUT OUTER LOX TANKS

3.2.1 Components of Vehicle Without Outer Lox Tanks

For the purpose of the analysis of the Vehicle Without Outer Lox Tanks, the configuration shown in Figure 130 was divided into four component structures. These component structures were then analyzed independently to obtain their mode shapes which were then used as generalized coordinates in the final coupling analysis of the Vehicle Without Outer Lox Tanks.

The first component selected was the same as that shown in Figure 117 (Upper Stage, U) and analyzed in Section 2.1 of this appendix. This analysis resulted in the determination of mode shapes as a 9×4 matrix, which are presented in Table 32. It may be recalled that the kinetic energy of the Upper Stage was written as

$$T = \frac{1}{2} \{\dot{p}_U\}' [A_U] \{\dot{p}_U\} \quad (\text{II-34})$$

The second component selected was the portion of the Vehicle Without Outer Lox Tanks shown in Figure 131, the elastic Middle Stage and rigid Upper Stage.

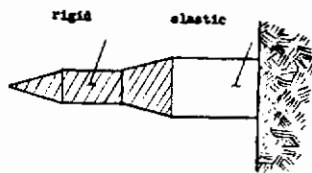

**FIGURE 131 SECOND COMPONENT OF
VEHICLE WITHOUT OUTER LOX TANKS**

The kinetic energy of this component was written as

$$T = \frac{1}{2} \{\dot{p}_M\}' \left([A_M] + [T_{UM}]' [A_U] [T_{UM}] \right) \{\dot{p}_M\} \quad (\text{II-35})$$

where $\{\dot{p}_M\}$ was the generalized velocities of (M).

$[A_M]$ was the collocation point mass matrix of (M) derived in Section 2.2.

$[T_{UM}]$ was a geometric transformation matrix which related the rigid motion of the Upper Stage to the elastic motion of the Middle Stage, and $[A_U]$ was the collocation point mass matrix of the Upper Stage derived in Section 2.1 of this appendix.

The mode shapes of this component of the Center Lox Tank Vehicle were determined through iteration of the expression,

$$[E_M]([A_M] + [T_{UM}]'(A_U)[T_{UM}])\{\psi\} = \lambda\{\psi\} \quad (II-36)$$

where $[E_M]$ was the collocation point structural influence coefficient matrix derived in Section 2.2, and

$[\Phi_M]$ was the 15 x 2 mode shape matrix for this portion of the Vehicle (presented in Table 32).

The third component selected was that portion of the Vehicle Without Outer Lox Tanks shown in Figure 132, the elastic adapter (A) and the rigid Middle and Upper Stages.

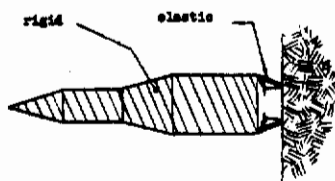

FIGURE 132 THIRD COMPONENT OF
VEHICLE WITHOUT OUTER LOX TANKS

The kinetic energy of this third portion was written in matrix notation as,

$$T = \frac{1}{2} \{\dot{p}_A\}' ([T_{MA}]'(A_M)[T_{MA}] + [T_{UA}]'(A_U)[T_{UA}]) \{\dot{p}_A\} \quad (II-37)$$

where,

$$[T_{UA}] = [T_{UM}][T_{MA}] \quad (II-38)$$

and where.

$\{\dot{p}_A\}$ was the matrix of generalized velocities of (A), and

$[T_{MA}]$ was a geometric transformation matrix which related the rigid motion of the Middle Stage to the Elastic motion of the Adapter (Note: all the transformation matrices used in this Section are presented in Table 31).

The mode shapes of this third component of the Vehicle Without Outer Lox Tanks were determined through iteration of the expression.

$$[E_A]([T_{MA}]^T[A_M][T_{MA}] + [T_{UA}]^T[A_U][T_{UA}])\{\varphi\} = \lambda\{\varphi\} \quad (II-39)$$

where $[E_A]$ was the collocation point influence matrix for the Adapter, (A) (derived in Section 2, 3, and

$\{\varphi_A\}$ was a 2 x 1 mode shape matrix for this portion of the Center Lox Tank Vehicle (presented in Table 32).

The fourth component of the Center Lox Tank Vehicle was the Center Lox Tank itself with all other components attached to it as rigid members as shown in Figure 133. Two rigid body modes were included, unit translation and unit pitch about the top of the spider beam.

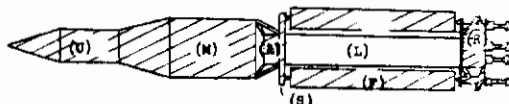

**FIGURE 133 FOURTH COMPONENT OF VEHICLE WITHOUT
OUTER LOX TANKS**

The kinetic energy of the fourth and final component of the Center Lox Tank Vehicle was expressed in matrix form as,

$$T = \frac{1}{2} \{\dot{p}_L\}^T \left([A_L] + [T_{UL}]^T [A_U] [T_{UL}] + [T_{SL}]^T [A_S] [T_{SL}] \right. \\ \left. + [T_{ML}]^T [A_M] [T_{ML}] + [T_{RL}]^T [A_R] [T_{RL}] \right. \\ \left. + + [T_{FL}]^T [A_F] [T_{FL}] \right) \{\dot{p}_L\} \quad (II-40)$$

where,

$$[T_{ML}] = [T_{MS}][T_{SL}] \quad (\text{II-41})$$

and, $[T_{MS}]$ was a geometric transformation matrix which related the motion of the rigid Middle Stage (M) to the motion of the Spider Beam (S), and

$[T_{LS}]$ was a geometric transformation matrix which related the motion of the rigid Spider Beam (S) to the elastic motion of the Center Lox Tank (L),

and where,

$$[T_{UL}] = [T_{UM}][T_{ML}] \quad (\text{II-42})$$

and where,

$$[T_{FL}] = [T_{FS}][T_{SL}] + [T_{FR}][T_{RL}] \quad (\text{II-43})$$

where $[T_{FS}]$ was a geometric transformation matrix which related the motion of the rigid Fuel Tank (F) to the motion of the Spider Beam (S).

$[T_{FR}]$ was a geometric transformation matrix which related the motion of the rigid Fuel Tank (F) to the motion of the Outrigger (R), and

$[T_{RL}]$ was a geometric transformation matrix which related the motion of the Outrigger to the motion of the Center Lox Tank,

and where, $[A_L]$ was the collocation point mass matrix for the Center Lox Tank (derived in Section 2.5),

$[A_S]$ was the collocation point mass matrix for the Spider Beam (derived in Section 2.4),

$[A_R]$ was the collocation point mass matrix for the Outrigger (derived in Section 2.7),

$[A_F]$ was the collocation point mass matrix for the Fuel Tanks (derived in Section 2.6), and

$\{\dot{p}_L\}$ was a matrix of generalized velocities for the Center Lox Tank.

The mode shapes of the fourth component of the Vehicle Without Outer Lox Tanks were determined through iteration of the expression,

$$\begin{aligned}
 [E_L] \left([A_L] + [T_{UL}]' [A_U] [T_{UL}] + [T_{SL}]' [A_S] [T_{SL}] \right. \\
 \left. + [T_{ML}]' [A_M] [T_{ML}] + [T_{RL}]' [A_R] [T_{RL}] \right. \\
 \left. + 4 [T_{FL}]' [A_F] [T_{FL}] \right) \{\varphi\} = \lambda \{\varphi\}
 \end{aligned}
 \tag{II-44}$$

where $[E_L]$ was the collocation point structural influence coefficient matrix for the Center Lox Tank (derived in Section of this part of the report), and

$[\varphi_L]$ was a 15 x 10 mode shape matrix for this fourth component of the Center Lox Tank Vehicle (presented in Table 32). It should perhaps be noted that two of these modes were rigid body modes while the remaining eight were elastic modes.

3.2.2 Modes of Vehicle Without Outer Lox Tanks

The mode shapes and natural frequencies of the entire Vehicle Without Outer Lox Tanks were determined in much the same manner as were the mode shapes and frequencies of its components. The kinetic energy of the Vehicle was expressed as the sum of the kinetic energies of its parts and appeared in matrix form as,

$$\begin{aligned}
 T = \frac{1}{2} \left(\{\dot{p}_U\}' [A_U] \{\dot{p}_U\} + \{\dot{p}_M\}' [A_M] \{\dot{p}_M\} + \{\dot{p}_S\}' [A_S] \{\dot{p}_S\} \right. \\
 \left. + \{\dot{p}_F^{(1)}\}' [A_F] \{\dot{p}_F^{(1)}\} + \{\dot{p}_F^{(2)}\}' [A_F] \{\dot{p}_F^{(2)}\} + \{\dot{p}_F^{(3)}\}' [A_F] \{\dot{p}_F^{(3)}\} \right. \\
 \left. + \{\dot{p}_F^{(4)}\}' [A_F] \{\dot{p}_F^{(4)}\} + \{\dot{p}_R\}' [A_R] \{\dot{p}_R\} + \{\dot{p}_L\}' [A_L] \{\dot{p}_L\} \right)
 \end{aligned}
 \tag{II-45}$$

Contrails

It should perhaps be noted that $\{p\}$ represents the generalized coordinates of a component. Each of these generalized coordinate matrices were then related to modal coordinates, $\{q\}$, by the relations;

$$\{p_U\} = \underbrace{[\tau_{UM}]\{p_M\}}_{\substack{\text{rigid displacements} \\ \text{of (U) due to} \\ \text{motion of (M)}}} + \underbrace{[\varphi_U]\{q_U\}}_{\substack{\text{elastic motion} \\ \text{of (U)} \\ \text{relative to (M)}}} \quad (\text{II-46})$$

$$\{p_M\} = \underbrace{[\tau_{ML}]\{p_L\}}_{\substack{\text{rigid displacements} \\ \text{of (M) due to motion} \\ \text{of (L)}}} + \underbrace{[\tau_{MA}]\{p_A\}}_{\substack{\text{rigid displacements} \\ \text{of (M) relative} \\ \text{to (L) due to} \\ \text{deformation of (A)}}} + \underbrace{[\varphi_M]\{q_M\}}_{\substack{\text{elastic displacements} \\ \text{of (M)}}} \quad (\text{II-47})$$

$$\{p_A\} = \{\varphi_A\} q_A \quad (\text{II-48})$$

$$\{p_S\} = [\tau_{SL}]\{p_L\} \quad (\text{II-49})$$

$$\{p_R\} = [\tau_{RL}]\{p_L\} \quad (\text{II-50})$$

$$\{p_F^{(1)}\} = [\tau_{FL}]\{p_L\} + [\varphi_F]\{q_F^{(1)}\} \quad (\text{II-51})$$

$$\{p_F^{(2)}\} = [\tau_{FL}]\{p_L\} + [\varphi_F]\{q_F^{(2)}\} \quad (\text{II-52})$$

$$\{p_F^{(3)}\} = [\tau_{FL}]\{p_L\} + [\varphi_F]\{q_F^{(3)}\} \quad (\text{II-53})$$

$$\{p_F^{(4)}\} = [\tau_{FL}]\{p_L\} + [\varphi_F]\{q_F^{(4)}\} \quad (\text{II-54})$$

$$\{p_L\} = [\varphi_L]\{q_L\} \quad (\text{II-55})$$

The modal coordinates associated with the entire Center Lox Tank Vehicle, $\{q_B\}$, were then defined by the relation,

$$\{q_B\} = \begin{bmatrix} \{q_U\} \\ \{q_M\} \\ q_A \\ \{q_F^{(1)}\} \\ \{q_F^{(2)}\} \\ \{q_F^{(3)}\} \\ \{q_L\} \end{bmatrix} \quad (\text{II-56})$$

Contrails

Attention should be called to the $\{q_F^{(1)}\}$, $\{q_F^{(2)}\}$, and $\{q_F^{(3)}\}$ modal coordinates. As shown in Figure 134, the modal coordinates $\{q_F^{(1)}\}$ were associated with Fuel Tanks number 1 and 3, and the modal coordinates $\{q_F^{(2)}\}$ and $\{q_F^{(3)}\}$ were associated with Fuel Tanks 2 and 4 respectively. This constraint restricted the Fuel Tanks to symmetric motion.

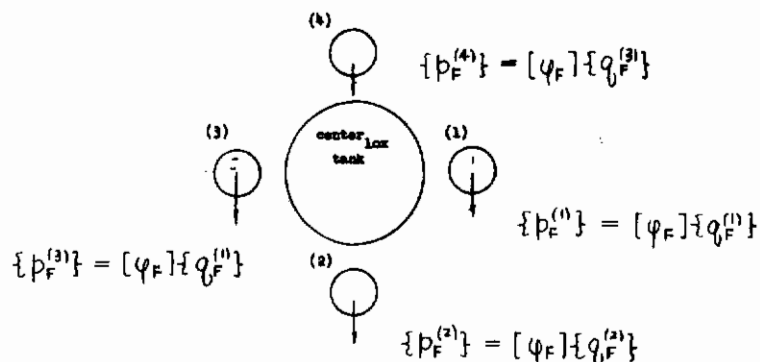

FIGURE 134 MODAL COORDINATES OF FUEL TANKS

The generalized coordinates of each part of the vehicle were then expressed in terms of the modal coordinates $\{q_B\}$ by combining expressions II-46 through II-55 with expression II-56 in the following manner:

$$(L) \quad \{p_L\} = [\Phi_L] \{q_B\} \tag{II-57}$$

$$[\Phi_L] = [[0], [0], \dots [0], [\varphi_L]]$$

$$(S) \quad \{p_S\} = [\Phi_S] \{q_B\} \tag{II-58}$$

$$[\Phi_S] = [\tau_{SL}] [\Phi_L] = [[0], \dots [0], [\tau_{SL}] [\varphi_L]]$$

Contrails

(M)

$$\{p_M\} = \{\Phi_M\} \{q_B\}$$

$$[\Phi_M] = [[0], [\varphi_M], [\tau_{MA}] \{ \varphi_A \}, [0], \dots [0], [\tau_{ML}] \{ \varphi_L \}]$$

(II-59)

(U)

$$\{p_U\} = \{\Phi_U\} \{q_B\}$$

$$[\Phi_U] = [[\varphi_U], [\tau_{UM}] \{ \varphi_M \}, \dots [0]]$$

(II-61)

(R)

$$\{p_R\} = \{\Phi_R\} \{q_B\}$$

$$[\Phi_R] = [[0], \dots [0], [\tau_{RL}] \{ \varphi_L \}]$$

(II-62)

Contrails

$$(F1) \quad \{p_F^{(1)}\} = [\Phi_F^{(1)}] \{q_B\} \quad (II-63)$$

$$[\Phi_F^{(1)}] = [[0], [0], [0], [\varphi_F], [0], [0], [\tau_{FL}]] [\varphi_L]$$

$$(F2) \quad \{p_F^{(2)}\} = [\Phi_F^{(2)}] \{q_B\} \quad (II-64)$$

$$[\Phi_F^{(2)}] = [[0], [0], [0], [0], [\varphi_F], [0], [\tau_{FL}]] [\varphi_L]$$

$$(F3) \quad \{p_F^{(3)}\} = [\Phi_F^{(3)}] \{q_B\} \quad (II-65)$$

$$(F4) \quad \{p_F^{(4)}\} = [\Phi_F^{(4)}] \{q_B\} \quad (II-66)$$

$$[\Phi_F^{(4)}] = [[0], [0], [0], [0], [0], [\varphi_F], [\tau_{FL}]] [\varphi_L]$$

Such that the kinetic energy was expressed in terms of the modal coordinates $\{q_B\}$ by combining Equations II-57 through II-66 with II-45 as shown in Equation II-67 below.

$$\begin{aligned} T = \frac{1}{2} \{ \dot{q}_B \}' & \left([\Phi_L]' [A_L] [\Phi_L] + [\Phi_S]' [A_S] [\Phi_S] + [\Phi_M]' [A_M] [\Phi_M] \right. \\ & + [\Phi_U]' [A_U] [\Phi_U] + [\Phi_R]' [A_R] [\Phi_R] \\ & + 2 [\Phi_F^{(1)}]' [A_F] [\Phi_F^{(1)}] + [\Phi_F^{(2)}]' [A_F] [\Phi_F^{(2)}] \\ & \left. + [\Phi_F^{(3)}]' [A_F] [\Phi_F^{(3)}] \right) \{ \dot{q}_B \} \end{aligned} \quad (II-67)$$

TABLE 31 GEOMETRIC TRANSFORMATION MATRICES FOR THE ELASTICALLY UNCOUPLED COMPONENTS

GEOMETRIC TRANSFORMATION FROM
DISPLACEMENTS OF UPPER STAGE TO
DISPLACEMENTS OF MIDDLE STAGE

ROW	COLUMN				
	1	2	3	4	5
1	3.00517E 00	1.60163E 01	-2.05929E 01	2.57143E 00	0.
2	2.62139E 00	1.41286E 01	-1.79983E 01	2.24806E 00	0.
3	2.23802E 00	1.22409E 01	-1.54037E 01	1.92469E 00	0.
4	1.85444E 00	1.03533E 01	-1.28090E 01	1.60133E 00	0.
5	1.47087E 00	8.46559E 00	-1.02144E 01	1.27796E 00	0.
6	1.08727E 00	6.57779E 00	-7.41963E 00	9.54571E-01	0.
7	7.03720E-01	4.69023E 00	-5.02517E 00	6.31224E-01	0.
8	3.20146E-01	2.80254E 00	-2.43055E 00	3.07857E-01	0.
9	-6.34778E-02	9.14622E-01	1.64407E-01	-1.55515E-02	0.

GEOMETRIC TRANSFORMATION FROM
DISPLACEMENTS OF MIDDLE STAGE TO
DISPLACEMENTS OF SPIDER BEAM

ROW	COLUMN		
	9	10	11
1	0.	1.00000E 00	9.54660E 01
2	0.	1.00000E 00	8.87480E 01
3	0.	1.00000E 00	8.20300E 01
4	0.	1.00000E 00	7.53120E 01
5	0.	1.00000E 00	6.85940E 01
6	0.	1.00000E 00	6.18750E 01
7	0.	1.00000E 00	5.51570E 01
8	0.	1.00000E 00	4.84390E 01
9	0.	1.00000E 00	4.17210E 01
10	0.	1.00000E 00	3.50030E 01
11	0.	1.00000E 00	2.82850E 01
12	0.	1.00000E 00	2.15670E 01
13	0.	1.00000E 00	1.48490E 01
14	0.	1.00000E 00	8.13100E 00
15	0.	1.00000E 00	1.41200E 00

GEOMETRIC TRANSFORMATION FROM
DISPLACEMENTS OF FUEL TANK TO
DISPLACEMENTS OF OUTRIGGER

ROW	COLUMN		
	1	2	3
1	0.	2.14499E-02	0.
2	0.	8.58799E-02	0.
3	0.	1.50310E-01	0.
4	0.	2.14740E-01	0.
5	0.	2.79170E-01	0.
6	0.	3.43607E-01	0.
7	0.	4.08037E-01	0.
8	0.	4.72467E-01	0.
9	0.	5.36897E-01	0.
10	0.	6.01326E-01	0.
11	0.	6.65756E-01	0.
12	0.	7.30186E-01	0.
13	0.	7.94616E-01	0.
14	0.	8.59046E-01	0.
15	0.	9.23483E-01	0.

GEOMETRIC TRANSFORMATION FROM
DISPLACEMENTS OF MIDDLE STAGE TO
DISPLACEMENTS OF ADAPTER

ROW	COLUMN	
	1	2
1	1.00000E 00	7.60790E 01
2	1.00000E 00	6.93610E 01
3	1.00000E 00	6.26430E 01
4	1.00000E 00	5.59250E 01
5	1.00000E 00	4.92070E 01
6	1.00000E 00	4.24880E 01
7	1.00000E 00	3.57700E 01
8	1.00000E 00	2.90520E 01
9	1.00000E 00	2.23340E 01
10	1.00000E 00	1.56160E 01
11	1.00000E 00	8.89800E 00
12	1.00000E 00	2.18000E 00
13	1.00000E 00	-4.53800E 00
14	1.00000E 00	-1.12560E 01
15	1.00000E 00	-1.79750E 01

GEOMETRIC TRANSFORMATION FROM
DISPLACEMENTS OF SPIDER BEAM TO
DISPLACEMENTS OF CENTER LOX TANK

ROW	COLUMN				
	1	2	3	4	5
10	1.25577E 00	-3.05164E-01	4.93959E-02	0.	0.
11	1.25687E-01	-1.48188E-01	2.25006E-02	0.	0.

GEOMETRIC TRANSFORMATION FROM
DISPLACEMENTS OF FUEL TANK TO
DISPLACEMENTS OF SPIDER BEAM

ROW	COLUMN		
	9	10	11
1	0.	9.78950E-01	0.
2	0.	9.14120E-01	0.
3	0.	8.49690E-01	0.
4	0.	7.85260E-01	0.
5	0.	7.20830E-01	0.
6	0.	6.56393E-01	0.
7	0.	5.91963E-01	0.
8	0.	5.27933E-01	0.
9	0.	4.63103E-01	0.
10	0.	3.98674E-01	0.
11	0.	3.34244E-01	0.
12	0.	2.69814E-01	0.
13	0.	2.05384E-01	0.
14	0.	1.40954E-01	0.
15	0.	7.65168E-02	0.

GEOMETRIC TRANSFORMATION FROM
DISPLACEMENTS OF OUTRIGGER TO
DISPLACEMENTS OF CENTER LOX TANK

ROW	COLUMN				
	11	12	13	14	15
2	0.	0.	5.09123E-02	-3.12536E-01	1.26202E 00
3	0.	0.	-2.23344E-02	1.47855E-01	-1.25921E-01

**TABLE 32
COMPONENT MODES OF VEHICLE WITHOUT OUTER LOX TANKS**

FIRST COMPONENT MODES OF (U)					SECOND COMPONENT MODES OF (M) WITH (U) RIGID		
COLL. POINT	1ST MODE 27.28 CPS	2ND MODE 89.04 CPS	3RD MODE 174.16 CPS	4TH MODE 273.08 CPS	COLL. POINT	1ST MODE 14.35 3PS	2ND MODE 89.95 CPS
1	9.6424360E-02	1.6796861E-01	2.4422816E-01	5.4789109E-01	001	1.0368176E-02	3.9002430E-02
2	8.1195670E-02	1.1838275E-01	1.4369598E-01	2.1827023E-01	2	8.1357344E-03	4.2117826E-03
3	6.6316996E-02	7.4647183E-02	7.3377694E-02	4.1197221E-02	3	5.3400034E-03	4.6145614E-02
4	5.0869723E-02	2.5571569E-02	-7.8173396E-03	-5.2769397E-02	4	4.5745228E-03	4.1368621E-02
5	3.4241724E-02	-2.3343700E-02	-3.8395116E-02	3.2723531E-02	5	3.6723826E-03	3.6501314E-02
6	1.7834081E-02	-4.1927207E-02	3.3220338E-02	6.1911686E-04	6	2.8791005E-03	3.1178227E-02
7	6.9849456E-03	-2.3426839E-02	3.2963625E-02	-3.1780140E-02	7	2.1629356E-03	2.5562352E-02
8	2.3468201E-03	-9.8140919E-03	1.4239716E-02	-1.5388012E-02	8	1.5321398E-03	1.9851100E-02
					9	9.9527779E-04	1.4268540E-02
					10	5.6116235E-04	9.0626127E-03
					11	2.3887028E-04	4.5261999E-03
					12	3.7481043E-05	9.2269560E-04
					13	8.0862670E-13	8.9651839E-12
					14	2.0572569E-13	2.3409367E-12

THIRD COMPONENT MODES OF (A) WITH (M) AND (U) RIGID	
	1ST MODE 6.995 CPS
1	5.1443060E-03
2	2.0488093E-04

FOURTH COMPONENT MODES OF (L) WITH ALL OTHER COMPONENTS RIGID								
COLL. POINT	1ST MODE 0 CPS	2ND MODE 0 CPS	3RD MODE 14.67 CPS	4TH MODE 70.92 CPS	5TH MODE 214.58 CPS	6TH MODE 519.59 CPS	7TH MODE 881.54 CPS	8TH MODE 1226 CPS
1	1.0000000E 00	-2.0000000E 00	4.2352995E-02	-1.1201244E-02	-8.0286235E-03	-6.4647484E-03	6.4918731E-03	-3.7809066E-04
2	1.0000000E 00	-1.1891000E 01	4.5449349E-02	-1.0168233E-02	9.4572790E-04	1.2988802E-02	-1.5081862E-02	-6.1849724E-03
3	1.0000000E 00	-2.1382000E 01	4.5520052E-02	-1.6736109E-04	5.3919579E-02	1.2262895E-01	-1.3364180E-01	-4.0611693E-02
4	1.0000000E 00	-3.1074001E 01	4.4994193E-02	1.0939494E-02	1.0833035E-01	2.1077825E-01	-1.7579772E-01	-1.1775114E-01
5	1.0000000E 00	-4.0765001E 01	4.3249546E-02	2.3551196E-02	1.6000935E-01	2.4853520E-01	-1.0716090E-01	-1.9265122E-01
6	1.0000000E 00	-5.0456001E 01	4.0377785E-02	3.6770886E-02	2.0230714E-01	2.2359037E-01	3.6415722E-02	-1.8239162E-01
7	1.0000000E 00	-6.0146999E 01	3.6475152E-02	4.9715651E-02	2.2988843E-01	1.4179841E-01	1.7328206E-01	-4.8190587E-02
8	1.0000000E 00	-6.9838001E 01	3.1637833E-02	6.1531699E-02	2.3910762E-01	2.4504056E-02	2.2527492E-01	1.4329112E-01
9	1.0000000E 00	-7.9529998E 01	2.5963215E-02	7.1404417E-02	2.2838459E-01	-9.5721021E-02	1.5521570E-01	2.5994834E-01
10	1.0000000E 00	-8.9221001E 01	1.9564505E-02	7.8503517E-02	1.9837614E-01	-1.8385224E-01	5.6083205E-04	1.9710509E-01
11	1.0000000E 00	-9.8911998E 01	1.2660979E-02	8.2305412E-02	1.5435452E-01	-2.1495710E-01	-1.4077358E-01	7.4143324E-03
12	1.0000000E 00	-1.0860300E 02	5.3284484E-03	8.2851511E-02	9.9639610E-02	-1.8781658E-01	-2.1031508E-01	-1.8430295E-01
13	1.0000000E 00	-1.1829400E 02	-2.3440015E-03	7.9696603E-02	3.9691722E-02	-1.1113700E-01	-1.6906330E-01	-2.2693398E-01
14	1.0000000E 00	-1.2798600E 02	-1.0137273E-02	7.5076619E-02	-2.3259111E-02	4.1482524E-04	-1.2677896E-02	-1.9673689E-02
15	1.0000000E 00	-1.3767700E 02	-1.9032816E-02	3.8356383E-02	-2.1000764E-02	1.3654361E-02	9.2433174E-03	1.2126091E-02

TABLE 33
FREQUENCIES OF THE VEHICLE WITHOUT OUTER LOX TANKS

	ANALYSIS OF THIS REPORT	VIBRATION TEST* RESULTS (WITH OUTER LOX TANKS)
1 st mode	(c.p.s.) 12.34	(c.p.s.) 13.4
2 nd mode	45.29	44.7
3 rd mode	71.13	
4 th mode	80.09	
5 th mode	80.59	
6 th mode	82.97	
7 th mode	93.31	
8 th mode	166.07	

*Taken from NASA TN D 1593, Investigation of the Lateral Vibration Characteristics of a 1/5-scale Model of Saturn SA-1 by John S. Mixson, John J. Catherine, and Ali Arman, January, 1963.

Contrails

The modal influence coefficient matrix, $[G_B]$, was then formed from the modal stiffness matrix by the method presented in Section 2.2.3.4 of this report, such that the "modal-mode shapes" and modal frequencies of the Center Lox Tank Vehicle were determined through the iteration of the expression,

$$[G_B][M_B]\{\pi\} = \lambda\{\pi\} \quad (\text{II-73})$$

such that $[\pi_c]$, the "modal-mode shapes" of the Center Lox Tank Vehicle, was a 26 x 10 matrix containing two rigid body modes and eight elastic modes.

It is somewhat disconcerting to find that the "modal-mode shape" matrix, $[\pi_c]$, has little or no direct physical interpretation. However, gratification is obtained through the use of an expression such as II-74. The deflections of the component structures may be determined in this manner and plotted to yield a picture of the complete vehicle in a particular bending mode. However, it should not be forgotten that the primary purpose of $[\pi_c]$ is the reduction of the number of degrees-of-freedom in the final coupling analysis.

$$\{p\} = [\Phi][\pi_c]\{q_c\} \quad (\text{II-74})$$

or

$$\{p\} = [\varphi_c]\{q_c\} \quad (\text{II-75})$$

where

$$[\varphi_c] = [\Phi][\pi_c] \quad (\text{II-76})$$

It should also be noted here that,

$$\{q_B\} = [\pi_c]\{q_c\} \quad (\text{II-77})$$

where $\{q_c\}$ was the final modal generalized coordinates of the Center Lox Tank Vehicle.

3.3 Coupling of Outer Lox Tanks With the Rest of the Vehicle

3.3.1 Analysis of Outer Lox Tanks

3.3.1.1 Outer Lox Tank Geometry and Basic Data

A schematic of one of the four outer lox tanks is shown in Figure 135.

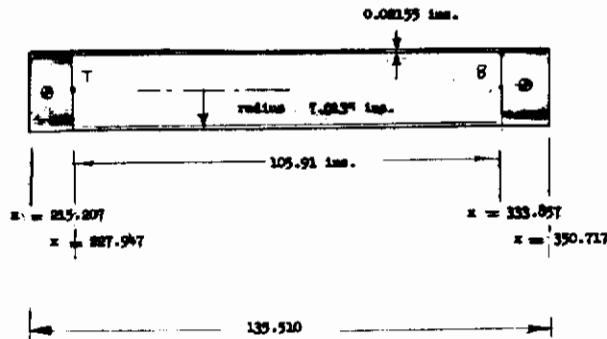



FIGURE 135 GEOMETRY OF OUTER LOX TANK

The inertia properties of the ends of the tank are:



$M_T = \text{mass} = 6.0202 \text{ lb}_M$
 $I_T = \text{moment of inertia about T.}$
 $= 490.51505 \text{ lb}_M \text{-in}$

$\bar{x}_T - x_T = \frac{46.010303}{6.0202} \text{ inches}$

$M_B = \text{mass} = 7.141 \text{ lb}_M$
 $I_B = \text{moment of inertia about B}$
 $= 869.57078 \text{ lb}_M \text{-in}^2$

$\bar{x}_B - x_B = \frac{67.12528}{7.141}$

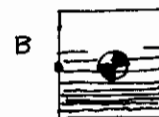

The shell has the following material properties

$$E = 10.6 \times 10^6 \text{ lb}_F/\text{in}^2 \quad (\text{II-78})$$

$$\nu = 0.3 \quad (\text{II-79})$$

$$G = 4.0769 \times 10^6 \text{ lb}_F/\text{in}^2 \quad (\text{II-80})$$

$$\rho = 0.1 \text{ lb}_M/\text{in}^3 \quad (\text{II-81})$$

The total mass of the shell is then

$$2 \pi b \tau L \rho = 10.0577 \text{ lb}_M \quad (\text{II-82})$$

and the total mass of one outer lox tank is 23.2189 lb_M

3.3.1.2 Outer Lox Tank Collocation Point Geometry and Generalized Coordinates

Fifteen points at equal intervals along the shell are shown in Figure 136.

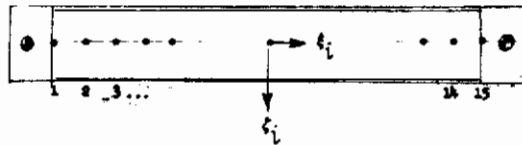

FIGURE 136 COLLOCATION POINTS

Each point is allowed 3 degrees-of-freedom ξ_i , η_i and ζ_i describing bending in two planes and longitudinal deformation.

In addition each end has five degrees-of-freedom as shown in Figure 137. These are



FIGURE 137 GENERALIZED COORDINATES FOR THE ENDS

Compatibility at the ends requires

$$\begin{aligned}
 \xi_1 &= \xi_T & (II-83) \\
 \xi_{15} &= \xi_B \\
 \eta_1 &= \eta_T \\
 \eta_{15} &= \eta_B \\
 \zeta_1 &= \zeta_T \\
 \zeta_{15} &= \zeta_B
 \end{aligned}$$

The complete set of generalized coordinates for the outer lox tank is then

(II-84)

$$\{b_T\} = \begin{bmatrix} s_T \\ s_2 \\ \vdots \\ s_B \\ \hline \theta_T \\ \psi_T \\ \psi_z \\ \vdots \\ s_B \\ \hline \theta_B \\ \psi_T \\ \psi_z \\ \vdots \\ \psi_B \\ \psi_B \end{bmatrix}$$

3.3.1.3 Outer Lox Tank Influence Coefficients and Modes

The influence coefficients for the structure cantilevered at $x = 333.857$ were first calculated by complementary energy techniques

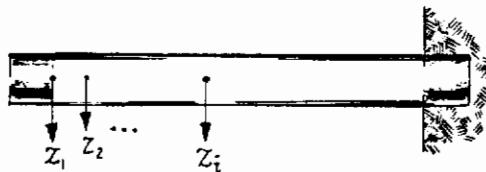

FIGURE 138 CANTILEVERED OUTER LOX TANK

These influence coefficients were then transformed to influence coefficients on simple supports as shown in Figure 139.

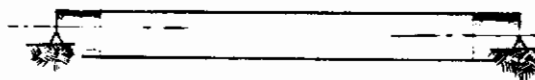

FIGURE 139 OUTER LOX TANK ON SIMPLE SUPPORTS

Contrails

The modes in bending were then obtained from

$${}^{17 \times 17} [E_T^{(S)}] [A_T^{(S)}] \{\psi\} = \lambda \{\psi\} \quad (\text{iterate for first 3 modes}) \quad (\text{II-85})$$

where $[A_T^{(S)}]$ includes inertia properties of the ends of the tank and it is assumed that the modes are the same in both planes.

The longitudinal modes were obtained from

$${}^{16 \times 16} [E_T^{(L)}] [A_T^{(L)}] \{\psi\} = \lambda \{\psi\} \quad (\text{iterate for first 2 modes}) \quad (\text{II-86})$$

where $[E_T^{(L)}]$ is the longitudinal influence coefficient for the tank constrained at $x = 350.717$.

3.3.1.4 Outer Lox Tank Modal Transformation Matrix

The complete set of modes for the lox tank are associated with the following generalized coordinates:

$\left. \begin{matrix} q_x^{(1)} \\ q_x^{(2)} \end{matrix} \right\}$ 2 longitudinal modes constrained at $X = 350.717$

q_F 1 rigid body rotation mode about $x = 350.717$ in the x-z plane

$\left. \begin{matrix} q_z^{(1)} \\ q_z^{(2)} \\ q_z^{(3)} \end{matrix} \right\}$ 3 lateral "pin-pin" modes in x-z plane

$\left. \begin{matrix} q_y^{(1)} \\ q_y^{(2)} \\ q_y^{(3)} \end{matrix} \right\}$ 3 lateral "pin-pin" modes in x-y plane

The complete modal transformation is

$$\begin{matrix} 47 \times 1 \\ \{p_T\} \end{matrix} = \begin{bmatrix} \{s\} \\ \theta_T \\ \{s\} \\ \theta_B \\ \psi_T \\ \{y\} \\ \psi_B \end{bmatrix} = \begin{bmatrix} {}^{15 \times 15} [\varphi_T^{(L)}] & & \\ & [x_T - x] [\varphi_T^{(S)}] & \\ & & {}^{12 \times 12} [\varphi_T^{(S)}] \end{bmatrix} \begin{bmatrix} q_x^{(1)} \\ q_x^{(2)} \\ q_F \\ q_z^{(1)} \\ q_z^{(2)} \\ q_z^{(3)} \\ q_y^{(1)} \\ q_y^{(2)} \\ q_y^{(3)} \\ q_y^{(1)} \\ q_y^{(2)} \\ q_y^{(3)} \end{bmatrix} \quad (\text{II-87})$$

which defines the 49 x 9 matrix $[\varphi_T]$.

The outer lox tanks are numbered as in Figure 140.

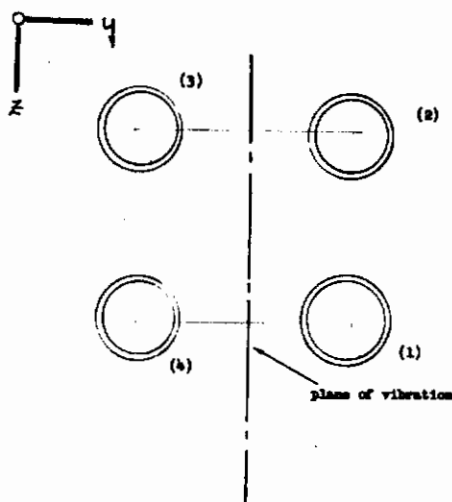

FIGURE 140 ARRANGEMENT OF FOUR OUTER LOX TANKS

The total displacements of the outer lox tanks are

(II-88)

$$\{b_r^{(1)}\} = [\varphi_T] \{q_r^{(1)}\} + [T_{TL}^{(1)}] \{p_L\}$$

$$\{b_r^{(2)}\} = [\varphi_T] \{q_r^{(2)}\} + [T_{TL}^{(2)}] \{p_L\}$$

(II-89)

motion of
outer lox
tanks relative
to center lox
tank

motion of rigid
outer lox tanks
due to motion of
center lox tank

Due to symmetry:

$$\{b_r^{(3)}\} = \{b_r^{(2)}\}$$

(II-90)

$$\{b_r^{(4)}\} = \{b_r^{(1)}\}$$

(II-91)

The geometric transformations can be considered as

$$[T_{TL}^{(1)}] = [T_{TR}^{(1)}] [T_{RL}]$$

(II-92)

where the displacements are first transformed to outrigger and then from outrigger to center lox tank.

3.3.2 Geometric Transformation Relating Motion of Rigid Outer Lox Tank to Outrigger

In deriving the geometric relations the tanks are assumed rigid and cantilivered to the outrigger

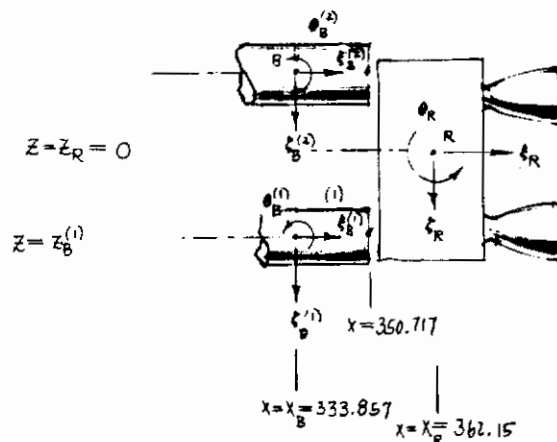

FIGURE 141 GEOMETRY OF OUTER LOX TANK - OUTRIGGER

At the joint the following is true (for the rigid tank with rigid joint)

$$z_B^{(1)} = z_R + (z_B^{(1)} - z_R) \theta_R \quad (\text{II-93})$$

$$z_B^{(2)} = z_R + (x_R - x_B) \theta_R$$

$$\theta_B^{(1)} = \theta_R$$

or

$$\begin{bmatrix} z_B^{(1)} \\ z_B^{(2)} \\ \theta_B^{(1)} \end{bmatrix} = \begin{bmatrix} 1 & 0 & z_B^{(1)} - z_R \\ 0 & 1 & x_R - x_B \\ 0 & 0 & 1 \end{bmatrix} \begin{bmatrix} z_R \\ \theta_R \\ \theta_R \end{bmatrix} \quad (\text{II-94})$$

Contrails

Also for the rigid tank

$$\begin{aligned}
 \{s\} &= \{1\} s_B^{(1)} & (II-95) \\
 \theta_r &= \theta_B^{(1)} \\
 \{J\} &= \{1\} J_B^{(1)} + \{x_B - x\} \theta_B^{(1)} \\
 \theta_B &= \theta_B^{(1)} \\
 \psi_r &= 0 \\
 \{y\} &= \{0\} \\
 \psi_B &= 0
 \end{aligned}$$

or

$$\{p_r^{(1)}\} = \begin{bmatrix} \{1\} & 0 & 0 \\ 0 & 0 & 0 \\ 0 & \{1\} & \{x_B - x\} \\ 0 & 0 & 0 \\ 0 & 0 & 0 \\ 0 & 0 & 0 \end{bmatrix} \begin{bmatrix} s_B^{(1)} \\ J_B^{(1)} \\ \theta_B^{(1)} \end{bmatrix} \quad (II-96)$$

$$\{p_r^{(1)}\} = \underbrace{\begin{bmatrix} \{1\} & 0 & 0 \\ 0 & 0 & 1 \\ 0 & \{1\} & \{x_B - x\} \\ 0 & 0 & 1 \\ 0 & 0 & 0 \end{bmatrix}}_{[T_{TR}^{(1)}]} \begin{bmatrix} 1 & 0 & -(z_R - z_B^{(1)}) \\ 0 & 1 & (x_R - x_B) \\ 0 & 0 & 1 \end{bmatrix} \{p_R\} \quad (II-97)$$

3.3.3 Spider-Outer Lox Tank Constraints

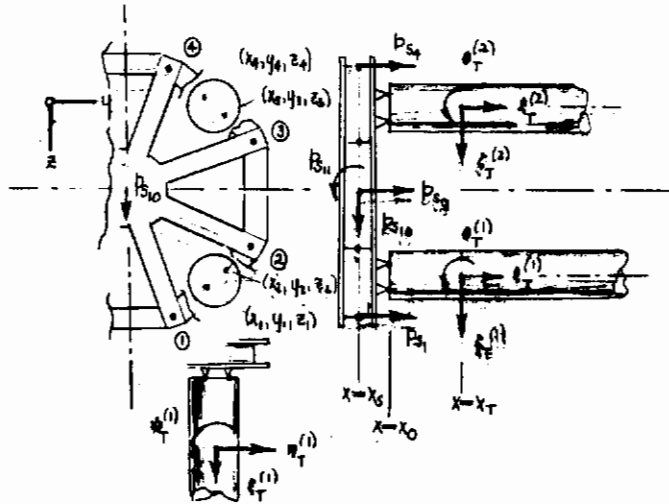

FIGURE 142 SPIDER BEAM - OUTER LOX TANK COMPATIBILITY

The compatibility relations at the joint can be written as

$$\psi_T^{(1)} - (x_T - x_0) \psi_T^{(1)} = 0 \quad (\text{II-98})$$

$$\delta_T^{(1)} + (x_T - x_0) \theta_T^{(1)} = p_{s10} - (x_0 - x_S) p_{s11} \quad (\text{II-99})$$

$$\begin{aligned} \delta_T^{(1)} + (z_1 - z_T^{(1)}) \theta_T^{(1)} - (y_1 - y_T^{(1)}) \psi_T^{(1)} \\ = \left(\frac{y_1 z_{S2} - z_1 y_{S2}}{y_1 z_{S2} - y_{S1} z_{S1}} \right) p_{S1} + \left(\frac{-y_1 z_{S1} + z_1 y_{S1}}{y_{S1} z_{S2} - y_{S1} z_{S1}} \right) p_{S2} \end{aligned} \quad (\text{II-100})$$

Contrails

$$\begin{aligned} \xi_T^{(n)} + (z_2 - z_T^{(n)}) \theta_T^{(n)} - (y_2 - y_T^{(n)}) \psi_T^{(n)} \\ = \left(\frac{y_2 z_{S_2} - z_2 y_{S_2}}{y_{S_1} z_{S_1} - y_{S_2} z_{S_1}} \right) p_{S_1} + \left(\frac{-y_2 z_{S_1} + z_2 y_{S_1}}{y_{S_1} z_{S_2} - y_{S_2} z_{S_1}} \right) p_{S_2} \end{aligned} \quad (\text{II-101})$$

or in matrix form

$$[L_T^{(1)}] \xi_T^{(1)} = [L_S^{(1)}] p_S \quad (\text{II-102})$$

$$[L_T^{(2)}] \xi_T^{(2)} = [L_S^{(2)}] p_S \quad (\text{II-103})$$

The total displacement of the spider beam is assumed to be

$$\{p_S\} = [T_{SL}] \xi_L + [\varphi_S] \{q_S\} \quad (\text{II-104})$$

where the spider beam "modes" are

$$[\varphi_S] = \begin{bmatrix} 1 & 0 & 0 & 0 \\ 0 & 1 & 0 & 0 \\ 0 & 0 & 1 & 0 \\ 0 & 0 & 0 & 1 \\ 0 & 0 & 0 & 1 \\ 0 & 0 & 1 & 0 \\ 0 & 1 & 0 & 0 \\ 1 & 0 & 0 & 0 \\ 0 & 0 & 0 & 0 \\ 0 & 0 & 0 & 0 \\ 0 & 0 & 0 & 0 \end{bmatrix}$$

$$(\text{II-105})$$

which describe a symmetric deformation defined by

$$\begin{aligned} p_S^{(1)} &= p_S^{(8)} \\ p_S^{(2)} &= p_S^{(7)} \\ p_S^{(3)} &= p_S^{(6)} \\ p_S^{(4)} &= p_S^{(5)} \end{aligned}$$

$$(\text{II-106})$$

and

$$p_s^{(1)} - p_s^{(2)} - p_s^{(3)} = 0 \quad (\text{II-107})$$

3.3.4 Modal Coupling for Natural Modes of Complete Vehicle

Rigid tanks - geometric transformation:

$$\{p_r^{(1)}\} = [T_{rL}^{(1)}] \{p_L\} \quad (\text{II-108})$$

$$\{p_r^{(2)}\} = [T_{rL}^{(2)}] \{p_L\} \quad (\text{II-109})$$

Spider beam-outer lox end constraints:

$$[L_r^{(1)}] \{p_r^{(1)}\} = [L_s^{(1)}] \{p_s\} \quad (\text{II-110})$$

$$[L_r^{(2)}] \{p_r^{(2)}\} = [L_s^{(2)}] \{p_s\} \quad (\text{II-111})$$

Modal coordinate transformations:

$$\{p_r^{(1)}\} = [\varphi_r] \{q_r^{(1)}\} + [T_{rL}^{(1)}] \{p_L\} \quad (\text{II-112})$$

$$\{p_r^{(2)}\} = [\varphi_r] \{q_r^{(2)}\} + [T_{rL}^{(2)}] \{p_L\} \quad (\text{II-113})$$

$$\{p_L\} = [\Phi_L] [\pi_c] \{q_c\} \quad (\text{II-114})$$

$$\{p_s\} = [T_{sL}] \{p_L\} + [\varphi_s] \{q_s\} \quad (\text{II-115})$$

Introduce

$$\{q_w\} = \begin{bmatrix} \{q_c\} & 10 \times 1 \\ \{q_r^{(1)}\} & 7 \times 1 \\ \{q_r^{(2)}\} & 7 \times 1 \\ \{q_s\} & 4 \times 1 \end{bmatrix} \quad (\text{II-116})$$

Constraints

Then we can write

$$\begin{aligned} \{p_L\} &= [\Phi_{LW}] \{q_W\} & \text{(II-117)} \\ \{p_r^{(1)}\} &= [\Phi_{rW}^{(1)}] \{q_W\} \\ \{p_r^{(2)}\} &= [\Phi_{rW}^{(2)}] \{q_W\} \\ \{p_s\} &= [\Phi_{sW}] \{q_W\} \end{aligned}$$

$$\begin{aligned} [\Phi_{LW}] &= [[\varphi_c^{(1)}], 0, 0, 0] & \text{(II-118)} \\ [\Phi_{rW}^{(1)}] &= [[T_r^{(1)}][\varphi_c^{(1)}], [\varphi_r], 0, 0] \\ [\Phi_{rW}^{(2)}] &= [[T_r^{(2)}][\varphi_c^{(1)}], 0, [\varphi_r], 0] \\ [\Phi_{sW}] &= [[T_{sL}][\varphi_c^{(1)}], 0, 0, [\varphi_s]] \end{aligned}$$

3.3.4.1 Constraint-Compatibility Matrix

$$[L^{(1)}][\Phi_{rW}^{(1)}] \{q_W\} = [L_s^{(1)}][\Phi_{sW}] \{q_W\} \quad \text{(II-119)}$$

$$[L^{(2)}][\Phi_{rW}^{(2)}] \{q_W\} = [L_s^{(2)}][\Phi_{sW}] \{q_W\} \quad \text{(II-120)}$$

or

$$[L] \{q_W\} = \{0\} \quad \text{(II-121)}$$

where

$$[L] = \begin{bmatrix} [L^{(1)}][\Phi_{rW}^{(1)}] - [L_s^{(1)}][\Phi_{sW}] \\ [L^{(2)}][\Phi_{rW}^{(2)}] - [L_s^{(2)}][\Phi_{sW}] \end{bmatrix} \quad \text{(II-122)}$$

Constraints

Let

$$\{q_w\} = [T_0] \{q_0\} + [T_v] \{q_v\} \quad (\text{II-123})$$

where $\{q_0\}$ = coordinates to be eliminated by use of constraint conditions

$$\{q_v\} = \begin{Bmatrix} \{q_c\} \\ \{q_r\} \\ \{q_s\} \end{Bmatrix} \quad (\text{II-124})$$

$$\{q_0\} = \begin{Bmatrix} \left[\begin{matrix} q_1^{(1)} \\ q_2^{(1)} \\ q_3^{(1)} \\ q_4^{(1)} \\ q_5^{(1)} \end{matrix} \right]_{(1)} \\ \left[\begin{matrix} q_1^{(2)} \\ q_2^{(2)} \\ q_3^{(2)} \\ q_4^{(2)} \\ q_5^{(2)} \end{matrix} \right]_{(2)} \end{Bmatrix} \quad (\text{II-125})$$

$$[L][T_0] \{q_0\} + [L][T_v] \{q_v\} = \{f_0\} \quad (\text{II-126})$$

$$\{q_0\} = -([L][T_0])^{-1} [L][T_v] \{q_v\} \quad (\text{II-127})$$

$$\{q_w\} = ([T_v] - [T_0]([L][T_0])^{-1} [L][T_v]) \{q_v\} \quad (\text{II-128})$$

$$\boxed{\{q_w\} = [T] \{q_v\}} \quad \text{compatibility matrix (II-129)}$$

Contrails

3.3.4.2 Kinetic Energy

$$T = \frac{1}{2} (\dot{q}_c)' [M_c] \dot{q}_c + 2 \dot{q}_T^{(1)'} [M_T] \dot{q}_T^{(1)} + 2 \dot{q}_T^{(2)'} [M_T] \dot{q}_T^{(2)} \quad (\text{II-130})$$

↑
two tanks per side

$$[M_c] = [\pi_c]' [M_\theta] [\pi_c] \quad (\text{II-131})$$

$$[M_T] = \begin{bmatrix} [I_1] & & & \\ & \begin{bmatrix} \frac{1}{2} \lambda_c - \lambda_1' & \\ & [A_T^{(1)}] \end{bmatrix} \begin{bmatrix} \lambda_c - \lambda_1 \\ & [\varphi_T^{(1)}] \end{bmatrix} & & \\ & & \begin{bmatrix} \frac{1}{2} \lambda_c - \lambda_1' & \\ & [A_T^{(2)}] \end{bmatrix} \begin{bmatrix} \lambda_c - \lambda_1 \\ & [\varphi_T^{(2)}] \end{bmatrix} & \\ & & & [I_1] \end{bmatrix} \quad (\text{II-132})$$

$$T = \frac{1}{2} \dot{q}_v' [M_v] \dot{q}_v \quad (\text{II-133})$$

$$[M_v] = [T]' \begin{bmatrix} [M_c] & & & \\ & 2[M_T] & & \\ & & 2[M_T] & \\ & & & [O] \end{bmatrix} [T] \quad (\text{II-134})$$

3.3.4.3 Strain Energy

$$U = \frac{1}{2} (\{q_c\}' r_{\lambda_c}^k \{q_c\} + 2 \{q_T^{(1)}\}' r_{\lambda_T}^k \{q_T^{(1)}\} + 2 \{q_T^{(2)}\}' r_{\lambda_T}^k \{q_T^{(2)}\} + \{q_s\}' [F_s] \{q_s\}) \quad (\text{II-135})$$

Contrails

$$[\lambda_c] = \begin{bmatrix} 0 & & & & \\ & 0 & & & \\ & & \lambda_c^{(1)} & & \\ & & & \lambda_c^{(2)} & \dots \\ & & & & \lambda_c^{(n)} \end{bmatrix} \quad (\text{II-136})$$

$$[\lambda_T] = \begin{bmatrix} \lambda_T^{(1)} & & & & \\ & \lambda_T^{(2)} & & & \\ & & \text{longitudinal} & & \\ & & 0 & \text{flapping stiffness} & \\ & & & & \lambda_T^{(n)} \\ & & & & & \lambda_T^{(1)} \\ & & & & & & \lambda_T^{(2)} \\ & & & & & & & \lambda_T^{(n)} \\ & & & & & & & & \lambda_T^{(1)} \\ & & & & & & & & & \lambda_T^{(2)} \\ & & & & & & & & & & \lambda_T^{(n)} \end{bmatrix} \quad (\text{II-137})$$

$$[F_s] = [\varphi_s]' [K_s] [\varphi_s] \quad (\text{II-138})$$

$$[K_s] = [V]' ([V]' [E_s] [V])^{-1} [V] \quad (\text{II-139})$$

$$U = \frac{1}{2} \{q_v\}' [F_v] \{q_v\} \quad (\text{II-140})$$

$$[F_v] = [T]' \begin{bmatrix} [\lambda_c] \\ \vdots \\ [\lambda_T] \\ \vdots \\ [F_s] \end{bmatrix} [T] \quad (\text{II-141})$$

$$[G_v] = [r]'[S]([S]'[F_v][S])^{-1}[S]'[r] \quad (\text{II-142})$$

$$[S] = \begin{bmatrix} 0 & & & & \\ & 0 & & & \\ & & \ddots & & \\ & & & \ddots & \\ & & & & 1 \end{bmatrix} \quad (\text{II-143})$$

$$[r] = [1] - [M_v][\pi_R]'([M_v][\pi_R])^{-1}[\pi_R]' \quad (\text{II-144})$$

$$[\pi_R] = \begin{bmatrix} 1 & 0 \\ 0 & 1 \\ 0 & 0 \\ \vdots & \vdots \\ 0 & 0 \end{bmatrix} \quad (\text{II-145})$$

3.3.4.4 Vibration Modes and Frequencies

Natural vibration modes and frequencies are obtained by iteration of

$$[G_v][M_v]\{\pi\} = \lambda \{\pi\} \quad (\text{II-146})$$

Contrails

Mode shapes:

(II-147)

$$\begin{aligned} \{p_L\} &= [\Phi_{LW}][\tau][\pi]\{q\} = [\varphi^{(L)}]\{q\} \\ \{p_T\} &= [\Phi_{TW}][\tau][\pi]\{q\} = [\varphi^{(T)}]\{q\} \\ \{p_r^{(2)}\} &= [\Phi_{rw}^{(2)}][\tau][\pi]\{q\} = [\varphi^{(r2)}]\{q\} \\ \{p_F^{(1)}\} &= [\Phi_F^{(1)}][\pi_c][\tau_c][\pi]\{q\} = [\varphi^{(F1)}]\{q\} \\ \{p_F^{(2)}\} &= [\Phi_F^{(2)}][\pi_c][\tau_c][\pi]\{q\} = [\varphi^{(F2)}]\{q\} \\ \{p_F^{(3)}\} &= [\Phi_F^{(3)}][\pi_c][\tau_c][\pi]\{q\} = [\varphi^{(F3)}]\{q\} \\ \{p_S\} &= [\Phi_{SW}][\tau][\pi]\{q\} = [\varphi^{(S)}]\{q\} \\ \{p_M\} &= [\Phi_M][\pi_c][\tau_c][\pi]\{q\} = [\varphi^{(M)}]\{q\} \\ \{p_U\} &= [\Phi_U][\pi_c][\tau_c][\pi]\{q\} = [\varphi^{(U)}]\{q\} \end{aligned}$$

APPENDIX III
COMPUTATIONAL PROCEDURES
FOR FINITE DEGREE-OF-FREEDOM
EIGENVALUE PROBLEMS

Contrails

1.0 INTRODUCTION

In this appendix we shall consider some numerical methods for solving the general eigenvalue problem. We shall consider the equations

$$[N(\lambda)]\{\varphi\} = \{0\} \quad (\text{III-1})$$

where $[N(\lambda)]$ is a function of the parameter λ such that $[N(\lambda)]$ is real when λ is real. Important special cases are

$$(1) \quad [N(\lambda)] = [A] - \lambda [K] \quad (\text{III-2})$$

$$(2) \quad [N(\lambda)] = \lambda [A] - [K] \quad (\text{III-3})$$

$$(3) \quad [N(\lambda)] = \lambda^2 [M] + \lambda \left(\frac{\partial x}{\partial t} [C_I] \right) + \left([F] + \frac{\partial^2 x}{\partial t^2} [C_R] \right) \quad (\text{III-4})$$

The first example is the eigenvalue problem of the general theory of vibrations. In the case of restrained systems, where $[K]^{-1}$ exists, it can be put in the same form as (2). It is shown in Section 2.2.3.4 that it can be put in the same form as (2) even when $[K]^{-1}$ does not exist. Case (2) represents, then, an important sub-case of the general problem:

$$[N]\{\varphi\} = \lambda \{\varphi\} \quad (\text{III-5})$$

When a real eigenvalue exists and it is the largest then the eigenvalue and eigenvector may be obtained from Equation III-5 by iteration.

When the problem indicates that complex eigenvalues may be present, the general case, Equation III-1, must be considered. The case of interest in this report, is expressed in Equation III-4 which has, in general, complex eigenvalues. Further examples are

$$(4) \quad [N(\lambda)] = \lambda^2 [A] + \lambda [B] + [K]; \quad [B]' = [B] \quad (\text{III-6})$$

which arises in the general theory of damped vibrations (see Section 2.2.3.5) and

$$(5) \quad [N(\lambda)] = \lambda^2 [A] + \lambda [G] + [K]; \quad [G]' = -[G] \quad (\text{III-7})$$

which arises in the general theory of vibrations about a point of steady motion

(examples are afforded by the vibrations of wings having large rotating machinery, vibrations of helicopter blades, perturbations of rotating space stations, perturbations of the 3-body problem, etc., etc.).

2.0 SOLUTIONS BY MATRIX ITERATION

When this method applies, the equation

$$[NH\varphi] = \lambda \{\varphi\} \quad (\text{III-8})$$

is solved by assuming a trial $\{\varphi\}$, say $\{\varphi\}_0$ and computing

$$\{\varphi\}_1 = [NH\varphi]_0 \quad (\text{III-9})$$

and

$$\lambda_1 = \frac{\{\varphi\}_1' [NH\varphi]_1}{\{\varphi\}_1' \{\varphi\}_1} \quad (\text{III-10})$$

$\{\varphi\}$ is normalized, for example by dividing by $\{\varphi\}'\{\varphi\}$ so that

$$\{\varphi\}'\{\varphi\} = 1 \quad (\text{III-11})$$

Then

$$\{\varphi\}_2 = [NH\varphi]_1 \quad (\text{III-12})$$

and the procedure is repeated. Proof of the convergence of the process in the case of a dominant real eigenvalue is given by Frazer, Duncan, and Collar¹.

3.0 SOLUTIONS TO THE GENERAL PROBLEM BY THE TAYLOR'S SERIES METHOD OF WIELANDT

3.1 Computational Procedure

The method to be described depends on having an estimate of the eigenvalue and eigenvectors of the problem

$$[N(\lambda)]\{\varphi\} = \{0\} \quad (\text{III-13})$$

¹Frazer, Duncan, and Collar, Elementary Matrices, Cambridge.

Contrails

The methods to obtain these estimates will be considered in Section 3.2 of this appendix. Let us denote the estimate of the eigenvalue by λ_i and the estimate of the eigenvector by $\{\varphi\}_i$. Then, if λ is an eigenvalue of III-13, let

$$\lambda = \lambda_i + \Delta \tag{III-14}$$

where Δ is a correction which is to be made zero.

Expand $N(\lambda)$ in a Taylor's series about the point $\lambda = \lambda_i$

$$[N(\lambda)] = [N(\lambda_i)] + \left[\frac{dN}{d\lambda}(\lambda_i)\right](\lambda - \lambda_i) + \frac{1}{2!} \left[\frac{d^2N}{d\lambda^2}(\lambda_i)\right](\lambda - \lambda_i)^2 + \dots \tag{III-15}$$

or

$$[N(\lambda_i + \Delta)] = [N(\lambda_i)] + \left[\frac{dN}{d\lambda}(\lambda_i)\right]\Delta + \dots \tag{III-16}$$

... terms of
order of Δ^2

Let

$$\{\varphi\} = \{\varphi\}_i + \begin{bmatrix} 0 \\ \{\Delta\} \end{bmatrix} \tag{III-17}$$

(First element is uncorrected)

where $\{\varphi\}$ is an eigenvector of III-13

Then

$$\begin{aligned} [N(\lambda)]\{\varphi\} &= \left([N(\lambda_i)] + \left[\frac{dN}{d\lambda}(\lambda_i)\right]\Delta\right) \left(\{\varphi\}_i + \begin{bmatrix} 0 \\ \{\Delta\} \end{bmatrix}\right) \\ &= [N(\lambda_i)]\{\varphi\}_i \\ &\quad + \left[\frac{dN}{d\lambda}(\lambda_i)\right]\{\varphi\}_i \Delta \\ &\quad + [N(\lambda_i)] \begin{bmatrix} 0 \\ \{\Delta\} \end{bmatrix} \\ &\quad + \left[\frac{dN}{d\lambda}(\lambda_i)\right] \begin{bmatrix} 0 \\ \{\Delta\} \end{bmatrix} \Delta \end{aligned} \tag{III-18}$$

This term is second order

Since λ and $\{\varphi\}$ are solutions to III-13 we have

$$[N(\lambda_i)]\{\varphi\}_i + \left[\frac{dN}{d\lambda}(\lambda_i)\right]\{\varphi\}_i \Delta + [N(\lambda_i)] \begin{bmatrix} 0 \\ \{\Delta\} \end{bmatrix} = \{0\} \tag{III-19}$$

Contrails

If

$$[\tau] = \begin{bmatrix} \{0\}' \\ \{1\} \end{bmatrix} \quad (\text{III-20})$$

then we can write

$$[N(\lambda_i)]\{ \varphi \}_i + \left[\frac{dN}{d\lambda}(\lambda_i) \right] \{ \varphi \}_i \Delta + [N(\lambda_i)][\tau] \{ \Delta \} = \{ 0 \} \quad (\text{III-21})$$

These equations may be solved for the corrections

$$\left[\left[\frac{dN}{d\lambda}(\lambda_i) \right] \{ \varphi \}_i, [N(\lambda_i)][\tau] \right] \begin{bmatrix} \Delta \\ \{ \Delta \} \end{bmatrix} = -[N(\lambda_i)] \{ \varphi \}_i \quad (\text{III-22})$$

$$\begin{bmatrix} \Delta \\ \{ \Delta \} \end{bmatrix} = \left[\left[\frac{dN}{d\lambda}(\lambda_i) \right] \{ \varphi \}_i, [N(\lambda_i)][\tau] \right]^{-1} [N(\lambda_i)] \{ \varphi \}_i \quad (\text{III-23})$$

Then compute

$$\{ \varphi \}_i \rightarrow \{ \varphi \}_i + [\tau] \{ \Delta \} \quad (\text{III-24})$$

$$\lambda_i \rightarrow \lambda_i + \Delta \quad (\text{III-25})$$

and iterate the procedure. For most problems the process converges satisfactorily in five to ten iterations. The process is repeated for the problem

$$[N(\lambda)] \{ \eta \} = \{ 0 \} \quad (\text{III-26})$$

starting with a "trial" λ_1 which is the converged value for the iteration for $\{ \varphi \}_i$. The solutions can be normalized by the condition

$$\{ \eta \}'_i \{ \varphi \}_i = 1 \quad (\text{III-27})$$

The above process fails for a repeated root.

3.2 Methods to Obtain Estimates for Use in Wielandt's Procedure

The common method for obtaining the eigenvalues from the solution of a polynomial is available when the problem is in the special form

$$[N(\lambda)] = \lambda \{ 1 \} - [N] \quad (\text{III-28})$$

Contrails

Most problems can be reduced to this "canonical" form by increasing the number of equations. For example, the third case (Equation III-4) can be reduced by taking [N] as

$$[N] = \begin{bmatrix} -\frac{\omega \gamma_0}{2} [M] [C_1] & -[M]^{-1} ([F] + \frac{\omega \gamma_0^2}{2} [C_R]) \\ \hline \Gamma_1 & [O] \end{bmatrix} \quad (\text{III-29})$$

In the canonical form, the determinant

$$\Delta(\lambda) = |\lambda \Gamma_1 - [N]| \quad (\text{III-30})$$

can be expanded into a polynomial by the method of Danielewski, and the resulting polynomial solved by Newton's method for the λ_i , $i = 1, 2, \dots, N$.

Approximate eigenvectors may be obtained, when the eigenvalues are known, by the following procedure

$$[N(\lambda_i)] \{\varphi\}_i = \begin{bmatrix} N_{11}(\lambda_i) & \{N_{12}(\lambda_i)\}' \\ \{N_{21}(\lambda_i)\} & [N_{22}(\lambda_i)] \end{bmatrix} \begin{bmatrix} 1 \\ \{\varphi\}_i \end{bmatrix} = \begin{bmatrix} 0 \\ \{0\} \end{bmatrix} \quad (\text{III-31})$$

then

$$\{\varphi\}_i = -[N_{22}(\lambda_i)]^{-1} \{N_{21}(\lambda_i)\} \quad (\text{III-32})$$

and

$$\{\varphi\}_i = \begin{bmatrix} 1 \\ -[N_{22}(\lambda_i)]^{-1} \{N_{21}(\lambda_i)\} \end{bmatrix} \quad (\text{III-33})$$

This procedure is not generally very accurate¹, but it suffices to obtain estimates for Weilandt's method.

¹This is true because of Rayleigh's theorem which says that eigenvalues are insensitive to errors in the eigenvectors they are calculated from. Conversely, the eigenvectors are poorly determined from the eigenvalues.

Contrails

A routine incorporating Danielewski expansion and Wielandt's method has been used with considerable success at LTV Astronautics. The choice of this combination over other possible methods was largely based on a survey article by Paul A. White¹ and suggestions by Mario Rheinfurth of the NASA Marshall Space Flight Center².

¹See White, Paul A. The Computation of Eigenvalues and Eigen Vectors of a Matrix Journal of the Society of Industrial and Applied Mathematics, Vol. 6, No. 4, December, 1958.

²Rheinfurth, Mario Control-Feedback Stability Analysis ABMA Report No. DA-TR-2-60 January 1960.

APPENDIX IV
INTERPOLATION AND INTEGRATION
COEFFICIENTS FOR
DIPARABOLIC INTERPOLATION

Contrails

TABLE 34
TWO-DIMENSIONAL DIPARABOLIC INTERPOLATION COEFFICIENTS

TWO-DIMENSIONAL DIPARABOLIC
INTERPOLATION COEFFICIENTS FOR
A REGION ON THE UPPER EDGE

COLUMNS

ROW	5	6	7	8	9	10	11	12	13	14	15	16
1	0.	1.000000E 00	0.	0.	0.	0.	1.500000E 00	0.	2.500000E-01	0.	-2.500000E-01	0.
2	1.500000E-01	-1.625000E 00	3.000000E-01	-7.499999E-02	0.	1.500000E 00	0.	0.	0.	-2.500000E-01	0.	0.
3	-3.000000E-01	7.499997E-01	-5.999999E-01	1.500000E-01	0.	0.	0.	0.	0.	0.	0.	0.
4	-5.000000E-01	0.	5.000000E-01	0.	0.	0.	0.	0.	0.	0.	0.	0.
5	0.	0.	0.	0.	0.	0.	0.	0.	0.	0.	0.	0.
6	1.250000E 00	0.	-1.250000E 00	0.	-1.500000E 00	0.	1.500000E 00	0.	2.500000E-01	0.	-2.500000E-01	0.
7	1.000000E 00	-2.500000E 00	2.000000E 00	-5.000000E-01	0.	0.	0.	0.	0.	0.	0.	0.
8	-6.749997E-01	5.774999E 00	-5.774999E 00	6.749999E-01	0.	-4.500000E 00	4.500000E 00	0.	0.	7.500000E-01	-7.500000E-01	0.
9	-1.150000E 00	-5.299998E 00	6.549997E 00	-9.999991E-02	3.000000E 00	1.500000E 00	-3.000000E 00	-1.500000E 00	-5.000000E-01	-2.500000E-01	5.000000E-01	2.500000E-01
10	-5.000000E-01	1.500000E 00	-1.500000E 00	5.000000E-01	0.	0.	0.	0.	0.	0.	0.	0.
11	4.499999E-01	-3.850000E 00	3.849999E 00	-4.499998E-01	0.	3.000000E 00	-3.000000E 00	0.	0.	-5.000000E-01	5.000000E-01	0.
12	3.500000E-01	3.949999E 00	-3.949997E 00	-3.500000E-01	-1.500000E 00	-1.500000E 00	1.500000E 00	1.500000E 00	2.500000E-01	2.500000E-01	-2.500000E-01	-2.500000E-01
13	1.500000E-01	-1.249999E-01	3.000000E-01	-7.499999E-02	0.	-5.000000E-01	0.	0.	0.	2.500000E-01	0.	0.
14	-7.500000E-01	0.	7.500000E-01	0.	1.000000E 00	0.	-1.000000E 00	0.	-2.500000E-01	0.	2.500000E-01	0.
15	8.250000E-01	2.824999E 00	-2.774999E 00	-7.500000E-02	-2.000000E 00	5.000000E-01	5.000000E-01	1.000000E 00	5.000000E-01	-5.000000E-01	2.500000E-01	-2.500000E-01
16	-3.000000E-01	-1.600000E 00	1.599999E 00	3.000000E-01	1.000000E 00	0.	0.	-1.000000E 00	-2.500000E-01	2.500000E-01	-2.500000E-01	2.500000E-01

TWO-DIMENSIONAL QUADRATIC
INTERPOLATION COEFFICIENTS FOR
AN INTERIOR REGION

ROW	COLUMN	ROW	COLUMN	ROW	COLUMN	ROW	COLUMN	ROW	COLUMN	ROW	COLUMN	ROW	COLUMN	ROW	COLUMN
1	0.	1	0.	1	0.	1	0.	1	0.	1	0.	1	0.	1	0.
2	-5.000000E-01	2	0.	2	0.	2	0.	2	0.	2	0.	2	0.	2	0.
3	1.000000E 00	3	0.	3	0.	3	0.	3	0.	3	0.	3	0.	3	0.
4	2.500000E-01	4	-2.500000E-01	4	0.	4	-5.000000E-01	4	0.	4	5.000000E-01	4	0.	4	0.
5	-5.000000E-01	5	5.000000E-01	5	0.	5	0.	5	0.	5	0.	5	0.	5	0.
6	1.000000E 00	6	-1.000000E 00	6	0.	6	1.250000E 00	6	0.	6	-1.250000E 00	6	0.	6	0.
7	-5.000000E-01	7	1.000000E 00	7	2.500000E-01	7	0.	7	1.000000E 00	7	-2.500000E 00	7	0.	7	0.
8	1.000000E 00	8	2.000000E 00	8	0.	8	-5.000000E-01	8	0.	8	2.500000E 00	8	0.	8	0.
9	2.500000E-01	9	7.500000E-01	9	-2.500000E-01	9	0.	9	-2.500000E 00	9	6.250000E 00	9	0.	9	1.250000E 00
10	-5.000000E-01	10	1.500000E 00	10	5.000000E-01	10	0.	10	-5.000000E-01	10	1.500000E 00	10	0.	10	5.000000E-01
11	1.000000E 00	11	-1.000000E 00	11	0.	11	0.	11	0.	11	0.	11	0.	11	0.
12	-5.000000E-01	12	5.000000E-01	12	0.	12	0.	12	1.250000E 00	12	-3.750000E 00	12	0.	12	3.750000E 00
13	1.000000E 00	13	-2.500000E-01	13	0.	13	0.	13	0.	13	1.500000E 00	13	0.	13	0.
14	2.500000E-01	14	-2.500000E-01	14	0.	14	0.	14	-7.500000E-01	14	0.	14	0.	14	7.500000E-01
15	-5.000000E-01	15	1.000000E 00	15	2.500000E-01	15	0.	15	1.500000E 00	15	-3.750000E 00	15	0.	15	3.000000E 00
16	2.500000E-01	16	7.500000E-01	16	-2.500000E-01	16	0.	16	-7.500000E-01	16	2.250000E 00	16	0.	16	-2.250000E 00
17	0.	17	5.000000E-01	17	0.	17	0.	17	0.	17	0.	17	0.	17	0.
18	1.000000E 00	18	2.000000E 00	18	0.	18	0.	18	0.	18	0.	18	0.	18	0.
19	2.500000E-01	19	7.500000E-01	19	-2.500000E-01	19	0.	19	0.	19	0.	19	0.	19	0.
20	-5.000000E-01	20	1.500000E 00	20	5.000000E-01	20	0.	20	0.	20	0.	20	0.	20	0.
21	1.000000E 00	21	-1.000000E 00	21	0.	21	0.	21	0.	21	0.	21	0.	21	0.
22	-5.000000E-01	22	5.000000E-01	22	0.	22	0.	22	0.	22	0.	22	0.	22	0.
23	1.000000E 00	23	-2.500000E-01	23	0.	23	0.	23	0.	23	0.	23	0.	23	0.
24	2.500000E-01	24	-2.500000E-01	24	0.	24	0.	24	0.	24	0.	24	0.	24	0.
25	-5.000000E-01	25	1.000000E 00	25	2.500000E-01	25	0.	25	0.	25	0.	25	0.	25	0.
26	2.500000E-01	26	7.500000E-01	26	-2.500000E-01	26	0.	26	0.	26	0.	26	0.	26	0.
27	0.	27	5.000000E-01	27	0.	27	0.	27	0.	27	0.	27	0.	27	0.
28	1.000000E 00	28	2.000000E 00	28	0.	28	0.	28	0.	28	0.	28	0.	28	0.
29	2.500000E-01	29	7.500000E-01	29	-2.500000E-01	29	0.	29	0.	29	0.	29	0.	29	0.
30	-5.000000E-01	30	1.500000E 00	30	5.000000E-01	30	0.	30	0.	30	0.	30	0.	30	0.
31	1.000000E 00	31	-1.000000E 00	31	0.	31	0.	31	0.	31	0.	31	0.	31	0.
32	-5.000000E-01	32	5.000000E-01	32	0.	32	0.	32	0.	32	0.	32	0.	32	0.
33	1.000000E 00	33	-2.500000E-01	33	0.	33	0.	33	0.	33	0.	33	0.	33	0.
34	2.500000E-01	34	-2.500000E-01	34	0.	34	0.	34	0.	34	0.	34	0.	34	0.
35	-5.000000E-01	35	1.000000E 00	35	2.500000E-01	35	0.	35	0.	35	0.	35	0.	35	0.
36	2.500000E-01	36	7.500000E-01	36	-2.500000E-01	36	0.	36	0.	36	0.	36	0.	36	0.
37	0.	37	5.000000E-01	37	0.	37	0.	37	0.	37	0.	37	0.	37	0.
38	1.000000E 00	38	2.000000E 00	38	0.	38	0.	38	0.	38	0.	38	0.	38	0.
39	2.500000E-01	39	7.500000E-01	39	-2.500000E-01	39	0.	39	0.	39	0.	39	0.	39	0.
40	-5.000000E-01	40	1.500000E 00	40	5.000000E-01	40	0.	40	0.	40	0.	40	0.	40	0.
41	1.000000E 00	41	-1.000000E 00	41	0.	41	0.	41	0.	41	0.	41	0.	41	0.
42	-5.000000E-01	42	5.000000E-01	42	0.	42	0.	42	0.	42	0.	42	0.	42	0.
43	1.000000E 00	43	-2.500000E-01	43	0.	43	0.	43	0.	43	0.	43	0.	43	0.
44	2.500000E-01	44	-2.500000E-01	44	0.	44	0.	44	0.	44	0.	44	0.	44	0.
45	-5.000000E-01	45	1.000000E 00	45	2.500000E-01	45	0.	45	0.	45	0.	45	0.	45	0.
46	2.500000E-01	46	7.500000E-01	46	-2.500000E-01	46	0.	46	0.	46	0.	46	0.	46	0.
47	0.	47	5.000000E-01	47	0.	47	0.	47	0.	47	0.	47	0.	47	0.
48	1.000000E 00	48	2.000000E 00	48	0.	48	0.	48	0.	48	0.	48	0.	48	0.
49	2.500000E-01	49	7.500000E-01	49	-2.500000E-01	49	0.	49	0.	49	0.	49	0.	49	0.
50	-5.000000E-01	50	1.500000E 00	50	5.000000E-01	50	0.	50	0.	50	0.	50	0.	50	0.
51	1.000000E 00	51	-1.000000E 00	51	0.	51	0.	51	0.	51	0.	51	0.	51	0.
52	-5.000000E-01	52	5.000000E-01	52	0.	52	0.	52	0.	52	0.	52	0.	52	0.
53	1.000000E 00	53	-2.500000E-01	53	0.	53	0.	53	0.	53	0.	53	0.	53	0.
54	2.500000E-01	54	-2.500000E-01	54	0.	54	0.	54	0.	54	0.	54	0.	54	0.
55	-5.000000E-01	55	1.000000E 00	55	2.500000E-01	55	0.	55	0.	55	0.	55	0.	55	0.
56	2.500000E-01	56	7.500000E-01	56	-2.500000E-01	56	0.	56	0.	56	0.	56	0.	56	0.
57	0.	57	5.000000E-01	57	0.	57	0.	57	0.	57	0.	57	0.	57	0.
58	1.000000E 00	58	2.000000E 00	58	0.	58	0.	58	0.	58	0.	58	0.	58	0.
59	2.500000E-01	59	7.500000E-01	59	-2.500000E-01	59	0.	59	0.	59	0.	59	0.	59	0.
60	-5.000000E-01	60	1.500000E 00	60	5.000000E-01	60	0.	60	0.	60	0.	60	0.	60	0.
61	1.000000E 00	61	-1.000000E 00	61	0.	61	0.	61	0.	61	0.	61	0.	61	0.
62	-5.000000E-01	62	5.000000E-01	62	0.	62	0.	62	0.	62	0.	62	0.	62	0.
63	1.000000E 00	63	-2.500000E-01	63	0.	63	0.	63	0.	63	0.	63	0.	63	0.
64	2.500000E-01	64	-2.500000E-01	64	0.	64	0.	64	0.	64	0.	64	0.	64	0.
65	-5.000000E-01	65	1.000000E 00	65	2.500000E-01	65	0.	65	0.	65	0.	65	0.	65	0.
66	2.500000E-01	66	7.500000E-01	66	-2.500000E-01	66	0.	66	0.	66	0.	66	0.	66	0.
67	0.	67	5.000000E-01	67	0.	67	0.	67	0.	67	0.	67	0.	67	0.
68	1.000000E 00	68	2.000000E 00	68	0.	68	0.	68	0.	68	0.	68	0.	68	0.
69	2.500000E-01	69	7.500000E-01	69	-2.500000E-01	69	0.	69	0.	69	0.	69	0.	69	0.
70	-5.000000E-01	70	1.500000E 00	70	5.000000E-01	70	0.	70	0.	70	0.	70	0.	70	0.
71	1.000000E 00	71	-1.000000E 00	71	0.	71	0.	71	0.	71	0.	71	0.	71	0.
72	-5.000000E-01	72	5.000000E-01	72	0.	72	0.	72	0.	72	0.	72	0.	72	0.
73	1.000000E 00	73	-2.500000E-01	73	0.	73	0.	73	0.	73	0.	73	0.	73	0.
74	2.500000E-01	74	-2.500000E-01	74	0.	74	0.	74	0.	74	0.	74	0.	74	0.
75	-5.000000E-01	75	1.000000E 00	75	2.500000E-01	75	0.	75	0.	75	0.	75	0.	75	0.
76	2.500000E-01	76	7.500000E-01	76	-2.500000E-01	76	0.	76	0.	76	0.	76	0.	76	0.
77	0.	77	5.000000E-01	77	0.	77	0.	77	0.	77	0.	77	0.	77	0.
78	1.000000E 00	78	2.000000E 00	78	0.	78	0.	78	0.	78	0.	78	0.	78	0.
79	2.500000E-01	79	7.500000E-01	79	-2.500000E-01	79	0.	79	0.	79	0.	79	0.	79	0.
80	-5.000000E-01	80	1.500000E 00	80	5.000000E-01	80	0.	80	0.	80	0.	80	0.	80	0.
81	1.000000E 00	81	-1.000000E 00	81	0.	81	0.	81	0.	81	0.	81	0.	81	0.
82	-5.000000E-01	82	5.000000E-01	82	0.	82	0.	82	0.	82	0.	82	0.	82	0.
83	1.000000E 00	83	-2.500000E-01	83	0.	83	0.	83	0.	83	0.	83	0.	83	0.
84	2.500000E-01	84	-2.500000E-01	84	0.	84	0.	84	0.	84	0.	84	0.	84	0.
85	-5.000000E-01	85	1.000000E 00	85	2.500000E-01	85	0.	85	0.	85	0.	85	0.	85	0.
86	2.500000E-01	86	7.500000E-01	86	-2.500000E-01	86	0.	86	0.	86	0.	86	0.	86	0.
87	0.	87	5.000000E-01	87	0.	87	0.	87	0.	87	0.	87	0.	87	0.
88	1.000000E 00	88	2.000000E 00	88	0.	88	0.	88	0.	88	0.	88	0.	88	0.
89	2.500000E-01	89	7.500000E-01	89	-2.500000E-01	89	0.	89	0.	89	0.	89	0		

TWO-DIMENSIONAL DIPARABOLIC INTERPOLATION COEFFICIENTS FOR A REGION ON THE LOWER EDGE

ADM COLUMN 1 2 3 4 5 6 7 8 9 10 11 12 13

1	0.	0.	0.	0.	0.	0.	0.	0.	0.	0.	0.	0.	0.
2	0.	-5.000000E-01	0.	0.	1.000000E 00	0.	0.	0.	0.	0.	0.	0.	0.
3	0.	7.499999E-01	0.	0.	-1.500000E 00	0.	0.	0.	0.	0.	0.	0.	0.
4	0.	0.	0.	-5.000000E-01	0.	5.000000E-01	0.	0.	0.	0.	0.	0.	0.
5	2.500000E-01	0.	-2.500000E-01	0.	1.500000E 00	-1.500000E 00	0.	0.	0.	0.	0.	0.	0.
6	-5.000000E-01	0.	4.999999E-01	0.	1.000000E 00	-1.000000E 00	0.	0.	0.	0.	0.	0.	0.
7	0.	0.	0.	0.	0.	0.	0.	0.	0.	0.	0.	0.	0.
8	-5.000000E-01	1.250000E 00	-1.000000E 00	2.500000E-01	1.000000E 00	-2.500000E 00	-5.000000E-01	0.	0.	0.	0.	0.	0.
9	1.000000E 00	-1.750000E 00	1.250000E 00	-6.999998E-01	-3.000000E 00	2.999995E 00	1.500000E 00	1.500000E 00	1.325000E 00	7.750002E-01	-1.775000E 00	-3.250000E-01	0.
10	0.	0.	0.	0.	0.	0.	0.	0.	0.	0.	0.	0.	0.
11	2.500000E-01	-7.500000E-01	7.500000E-01	-2.500000E-01	1.500000E 00	-1.500000E 00	5.000000E-01	0.	0.	0.	0.	0.	0.
12	-5.000000E-01	9.999999E-01	-9.999999E-01	4.999999E-01	1.500000E 00	-1.499999E 00	-1.500000E 00	0.	0.	0.	0.	0.	0.
13	0.	-2.499999E-01	0.	0.	4.999998E-01	0.	0.	0.	0.	0.	0.	0.	0.
14	2.500000E-01	0.	-2.500000E-01	0.	-9.999998E-01	1.000000E 00	0.	0.	0.	0.	0.	0.	0.
15	-5.000000E-01	5.000000E-01	-2.499998E-01	2.499999E-01	2.000000E 00	-4.999996E-01	-1.000000E 00	0.	0.	0.	0.	0.	0.
16	2.500000E-01	-2.500000E-01	2.499998E-01	-2.499999E-01	-1.000000E 00	-2.980232E-07	5.960464E-08	1.000000E 00	1.600000E 00	1.600000E 00	-1.600000E 00	-2.989999E-01	0.

TABLE 35
TWO-DIMENSIONAL DIPARABOLIC INTEGRATION MATRICES

TWO-DIMENSIONAL DIPARABOLIC
INTEGRATION COEFFICIENTS FOR
USE IN PLATE AND SHELL ANALYSES

$$[\Gamma_7]$$

ROW

COLUMN

	1	2	3	4
1	1.0000000E 00	5.0000000E-01	3.3333333E-01	5.0000000E-01
2	5.0000000E-01	3.3333333E-01	2.5000000E-01	2.5000000E-01
3	3.3333333E-01	2.5000000E-01	2.0000000E-01	1.6666667E-01
4	5.0000000E-01	2.5000000E-01	1.6666667E-01	3.3333333E-01
5	2.5000000E-01	1.6666667E-01	1.2500000E-01	1.6666667E-01
6	1.6666667E-01	1.2500000E-01	9.9999999E-02	1.1111111E-01
7	3.3333333E-01	1.6666667E-01	1.1111111E-01	2.5000000E-01
8	1.6666667E-01	1.1111111E-01	8.3333333E-02	1.2500000E-01
9	1.1111111E-01	8.3333333E-02	6.6666666E-02	8.3333333E-02
10	2.5000000E-01	1.2500000E-01	8.3333333E-02	2.0000000E-01
11	1.2500000E-01	8.3333333E-02	6.2500000E-02	9.9999999E-02
12	8.3333333E-02	6.2500000E-02	4.9999999E-02	6.6666666E-02
13	2.5000000E-01	2.0000000E-01	1.6666667E-01	1.2500000E-01
14	1.2500000E-01	9.9999999E-02	8.3333333E-02	8.3333333E-02
15	8.3333333E-02	6.6666666E-02	5.5555555E-02	6.2500000E-02
16	6.2500000E-02	4.9999999E-02	4.1666666E-02	4.9999999E-02

Contrails

ROW	COLUMN			
	5	6	7	8
1	2.5000000E-01	1.6666667E-01	3.3333333E-01	1.6666667E-01
2	1.6666667E-01	1.2500000E-01	1.6666667E-01	1.1111111E-01
3	1.2500000E-01	9.9999999E-02	1.1111111E-01	8.3333333E-02
4	1.6666667E-01	1.1111111E-01	2.5000000E-01	1.2500000E-01
5	1.1111111E-01	8.3333333E-02	1.2500000E-01	8.3333333E-02
6	8.3333333E-02	6.6666666E-02	8.3333333E-02	6.2500000E-02
7	1.2500000E-01	8.3333333E-02	2.0000000E-01	9.9999999E-02
8	8.3333333E-02	6.2500000E-02	9.9999999E-02	6.6666666E-02
9	6.2500000E-02	4.9999999E-02	6.6666666E-02	4.9999999E-02
10	9.9999999E-02	6.6666666E-02	1.6666667E-01	8.3333333E-02
11	6.6666666E-02	4.9999999E-02	8.3333333E-02	5.5555555E-02
12	4.9999999E-02	3.9999999E-02	5.5555555E-02	4.1666666E-02
13	9.9999999E-02	8.3333333E-02	8.3333333E-02	6.6666666E-02
14	6.6666666E-02	5.5555555E-02	6.2500000E-02	4.9999999E-02
15	4.9999999E-02	4.1666666E-02	4.9999999E-02	3.9999999E-02
16	3.9999999E-02	3.3333333E-02	4.1666666E-02	3.3333333E-02

Contrails

ROW	COLUMN			
	9	10	11	12
1	1.1111111E-01	2.5000000E-01	1.2500000E-01	8.3333333E-02
2	8.3333333E-02	1.2500000E-01	8.3333333E-02	6.2500000E-02
3	6.6666666E-02	8.3333333E-02	6.2500000E-02	4.9999999E-02
4	8.3333333E-02	2.0000000E-01	9.9999999E-02	6.6666666E-02
5	6.2500000E-02	9.9999999E-02	6.6666666E-02	4.9999999E-02
6	4.9999999E-02	6.6666666E-02	4.9999999E-02	3.9999999E-02
7	6.6666666E-02	1.6666667E-01	8.3333333E-02	5.5555555E-02
8	4.9999999E-02	8.3333333E-02	5.5555555E-02	4.1666666E-02
9	3.9999999E-02	5.5555555E-02	4.1666666E-02	3.3333333E-02
10	5.5555555E-02	1.4285714E-01	7.1428571E-02	4.7619047E-02
11	4.1666666E-02	7.1428571E-02	4.7619047E-02	3.5714285E-02
12	3.3333333E-02	4.7619047E-02	3.5714285E-02	2.8571428E-02
13	5.5555555E-02	6.2500000E-02	4.9999999E-02	4.1666666E-02
14	4.1666666E-02	4.9999999E-02	3.9999999E-02	3.3333333E-02
15	3.3333333E-02	4.1666666E-02	3.3333333E-02	2.7777778E-02
16	2.7777778E-02	3.5714285E-02	2.8571428E-02	2.3809524E-02

Contrails

ROW	COLUMN			
	13	14	15	16
1	2.5000000E-01	1.2500000E-01	8.3333333E-02	6.2500000E-02
2	2.0000000E-01	9.9999999E-02	6.6666666E-02	4.9999999E-02
3	1.6666667E-01	8.3333333E-02	5.5555555E-02	4.1666666E-02
4	1.2500000E-01	8.3333333E-02	6.2500000E-02	4.9999999E-02
5	9.9999999E-02	6.6666666E-02	4.9999999E-02	3.9999999E-02
6	8.3333333E-02	5.5555555E-02	4.1666666E-02	3.3333333E-02
7	8.3333333E-02	6.2500000E-02	4.9999999E-02	4.1666666E-02
8	6.6666666E-02	4.9999999E-02	3.9999999E-02	3.3333333E-02
9	5.5555555E-02	4.1666666E-02	3.3333333E-02	2.7777778E-02
10	6.2500000E-02	4.9999999E-02	4.1666666E-02	3.5714285E-02
11	4.9999999E-02	3.9999999E-02	3.3333333E-02	2.8571428E-02
12	4.1666666E-02	3.3333333E-02	2.7777778E-02	2.3809524E-02
13	1.4285714E-01	7.1428571E-02	4.7619047E-02	3.5714285E-02
14	7.1428571E-02	4.7619047E-02	3.5714285E-02	2.8571428E-02
15	4.7619047E-02	3.5714285E-02	2.8571428E-02	2.3809524E-02
16	3.5714285E-02	2.8571428E-02	2.3809524E-02	2.0408163E-02

Contrails

TWO-DIMENSIONAL DIPARABOLIC INTEGRATION COEFFICIENTS FOR USE IN PLATE AND SHELL ANALYSES

$[r_2]$

ROW		1	2	3	4
3	0.		0.	4.0000000E 00	0.
6	0.		0.	2.0000000E 00	0.
9	0.		0.	1.3333333E 00	0.
12	0.		0.	1.0000000E 00	0.
13	0.		0.	6.0000000E 00	0.
14	0.		0.	3.0000000E 00	0.
15	0.		0.	2.0000000E 00	0.
16	0.		0.	1.5000000E 00	0.

ROW		5	6	7	8
3	0.		2.0000000E 00	0.	0.
6	0.		1.3333333E 00	0.	0.
9	0.		1.0000000E 00	0.	0.
12	0.		7.9999999E-01	0.	0.
13	0.		3.0000000E 00	0.	0.
14	0.		2.0000000E 00	0.	0.
15	0.		1.5000000E 00	0.	0.
16	0.		1.2000000E 00	0.	0.

Contrails

ROW	COLUMN			
	9	10	11	12
3	1.3333333E 00	0.	0.	1.0000000E 00
6	1.0000000E 00	0.	0.	7.9999999E-01
9	7.9999999E-01	0.	0.	6.6666666E-01
12	6.6666666E-01	0.	0.	5.7142857E-01
13	2.0000000E 00	0.	0.	1.5000000E 00
14	1.5000000E 00	0.	0.	1.2000000E 00
15	1.2000000E 00	0.	0.	9.9999999E-01
16	9.9999999E-01	0.	0.	8.5714284E-01

ROW	COLUMN			
	13	14	15	16
3	6.0000000E 00	3.0000000E 00	2.0000000E 00	1.5000000E 00
6	3.0000000E 00	2.0000000E 00	1.5000000E 00	1.2000000E 00
9	2.0000000E 00	1.5000000E 00	1.2000000E 00	9.9999999E-01
12	1.5000000E 00	1.2000000E 00	9.9999999E-01	8.5714284E-01
13	1.2000000E 01	5.9999999E 00	4.0000000E 00	3.0000000E 00
14	5.9999999E 00	4.0000000E 00	3.0000000E 00	2.4000000E 00
15	4.0000000E 00	3.0000000E 00	2.4000000E 00	2.0000000E 00
16	3.0000000E 00	2.4000000E 00	2.0000000E 00	1.7142857E 00

Contrails

TWO-DIMENSIONAL DIPARABOLIC INTEGRATION COEFFICIENTS FOR USE IN PLATE AND SHELL ANALYSES

[r_3]

ROW	COLUMN			
	5	6	7	8
7	0.	0.	4.0000000E 00	2.0000000E 00
8	0.	0.	2.0000000E 00	1.3333333E 00
9	0.	0.	1.3333333E 00	1.0000000E 00
10	0.	0.	6.0000000E 00	3.0000000E 00
11	0.	0.	3.0000000E 00	2.0000000E 00
12	0.	0.	2.0000000E 00	1.5000000E 00
15	0.	0.	1.0000000E 00	7.9999999E-01
16	0.	0.	1.5000000E 00	1.2000000E 00

ROW	COLUMN			
	9	10	11	12
7	1.3333333E 00	6.0000000E 00	3.0000000E 00	2.0000000E 00
8	1.0000000E 00	3.0000000E 00	2.0000000E 00	1.5000000E 00
9	7.9999999E-01	2.0000000E 00	1.5000000E 00	1.2000000E 00
10	2.0000000E 00	1.2000000E 01	5.9999999E 00	4.0000000E 00
11	1.5000000E 00	5.9999999E 00	4.0000000E 00	3.0000000E 00
12	1.2000000E 00	4.0000000E 00	3.0000000E 00	2.4000000E 00
15	6.6666666E-01	1.5000000E 00	1.2000000E 00	9.9999999E-01
16	9.9999999E-01	3.0000000E 00	2.4000000E 00	2.0000000E 00

Contrails

ROW		COLUMN			
		13	14	15	16
7	0.		0.	1.0000000E 00	1.5000000E 00
8	0.		0.	7.9999999E-01	1.2000000E 00
9	0.		0.	6.6666666E-01	9.9999999E-01
10	0.		0.	1.5000000E 00	3.0000000E 00
11	0.		0.	1.2000000E 00	2.4000000E 00
12	0.		0.	9.9999999E-01	2.0000000E 00
15	0.		0.	5.7142857E-01	8.5714284E-01
16	0.		0.	8.5714284E-01	1.7142857E 00

TWO-DIMENSIONAL DIPARABOLIC
INTEGRATION COEFFICIENTS FOR
USE IN PLATE AND SHELL ANALYSES

$[\Gamma_4]$

ROW	COLUMN			
	1	2	3	4
7	0.	0.	2.0000000E 00	0.
8	0.	0.	1.0000000E 00	0.
9	0.	0.	6.6666666E-01	0.
10	0.	0.	3.0000000E 00	0.
11	0.	0.	1.5000000E 00	0.
12	0.	0.	9.9999999E-01	0.
15	0.	0.	5.0000000E-01	0.
16	0.	0.	7.5000000E-01	0.

Contrails

ROW	5	6	7	8
3	0.	0.	2.0000000E 00	1.0000000E 00
6	0.	0.	1.0000000E 00	5.0000000E-01
7	0.	1.0000000E 00	0.	0.
8	0.	5.0000000E-01	0.	0.
9	0.	3.3333333E-01	6.6666666E-01	3.3333333E-01
10	0.	2.0000000E 00	0.	0.
11	0.	9.9999999E-01	0.	0.
12	0.	6.6666666E-01	5.0000000E-01	2.5000000E-01
13	0.	0.	3.0000000E 00	2.0000000E 00
14	0.	0.	1.5000000E 00	9.9999999E-01
15	0.	2.5000000E-01	9.9999999E-01	6.6666666E-01
16	0.	4.9999999E-01	7.5000000E-01	4.9999999E-01

Contrails

ROW

COLUMN

	9	10	11	12
3	6.6666666E-01	3.0000000E 00	1.5000000E 00	9.9999999E-01
6	3.3333333E-01	2.0000000E 00	9.9999999E-01	6.6666666E-01
7	6.6666666E-01	0.	0.	5.0000000E-01
8	3.3333333E-01	0.	0.	2.5000000E-01
9	4.4444444E-01	1.5000000E 00	7.5000000E-01	6.6666666E-01
10	1.5000000E 00	0.	0.	1.2000000E 00
11	7.5000000E-01	0.	0.	5.9999999E-01
12	6.6666666E-01	1.2000000E 00	5.9999999E-01	7.9999999E-01
13	1.5000000E 00	4.5000000E 00	3.0000000E 00	2.2500000E 00
14	7.5000000E-01	3.0000000E 00	2.0000000E 00	1.5000000E 00
15	6.6666666E-01	2.2500000E 00	1.5000000E 00	1.2500000E 00
16	7.5000000E-01	1.8000000E 00	1.2000000E 00	1.2000000E 00

ROW

COLUMN

	13	14	15	16
3	0.	0.	5.0000000E-01	7.5000000E-01
6	0.	0.	2.5000000E-01	4.9999999E-01
7	3.0000000E 00	1.5000000E 00	9.9999999E-01	7.5000000E-01
8	2.0000000E 00	9.9999999E-01	6.6666666E-01	4.9999999E-01
9	1.5000000E 00	7.5000000E-01	6.6666666E-01	7.5000000E-01
10	4.5000000E 00	3.0000000E 00	2.2500000E 00	1.8000000E 00
11	3.0000000E 00	2.0000000E 00	1.5000000E 00	1.2000000E 00
12	2.2500000E 00	1.5000000E 00	1.2500000E 00	1.2000000E 00
13	0.	0.	1.2000000E 00	1.8000000E 00
14	0.	0.	5.9999999E-01	1.2000000E 00
15	1.2000000E 00	5.9999999E-01	7.9999999E-01	1.2000000E 00
16	1.8000000E 00	1.2000000E 00	1.2000000E 00	1.4400000E 00

Contrails

TWO-DIMENSIONAL DIPARABOLIC INTEGRATION COEFFICIENTS FOR USE IN PLATE AND SHELL ANALYSES

[r_5]

ROW	COLUMN			
	5	6	7	8
5	1.0000000E 00	1.0000000E 00	0.	1.0000000E 00
6	1.0000000E 00	1.3333333E 00	0.	1.0000000E 00
8	1.0000000E 00	1.0000000E 00	0.	1.3333333E 00
9	1.0000000E 00	1.3333333E 00	0.	1.3333333E 00
11	9.9999999E-01	9.9999999E-01	0.	1.5000000E 00
12	9.9999999E-01	1.3333333E 00	0.	1.5000000E 00
14	9.9999999E-01	1.5000000E 00	0.	9.9999999E-01
15	9.9999999E-01	1.5000000E 00	0.	1.3333333E 00
16	9.9999999E-01	1.5000000E 00	0.	1.5000000E 00

ROW	COLUMN			
	9	10	11	12
5	1.0000000E 00	0.	9.9999999E-01	9.9999999E-01
6	1.3333333E 00	0.	9.9999999E-01	1.3333333E 00
8	1.3333333E 00	0.	1.5000000E 00	1.5000000E 00
9	1.7777778E 00	0.	1.5000000E 00	2.0000000E 00
11	1.5000000E 00	0.	1.8000000E 00	1.8000000E 00
12	2.0000000E 00	0.	1.8000000E 00	2.4000000E 00
14	1.5000000E 00	0.	9.9999999E-01	1.5000000E 00
15	2.0000000E 00	0.	1.5000000E 00	2.2500000E 00
16	2.2500000E 00	0.	1.8000000E 00	2.7000000E 00

Contrails

ROW		COLUMN			
		13	14	15	16
5	0.		9.9999999E-01	9.9999999E-01	9.9999999E-01
6	0.		1.5000000E 00	1.5000000E 00	1.5000000E 00
8	0.		9.9999999E-01	1.3333333E 00	1.5000000E 00
9	0.		1.5000000E 00	2.0000000E 00	2.2500000E 00
11	0.		9.9999999E-01	1.5000000E 00	1.8000000E 00
12	0.		1.5000000E 00	2.2500000E 00	2.7000000E 00
14	0.		1.8000000E 00	1.8000000E 00	1.8000000E 00
15	0.		1.8000000E 00	2.4000000E 00	2.7000000E 00
16	0.		1.8000000E 00	2.7000000E 00	3.2399999E 00

Contrails

TWO-DIMENSIONAL DIPARABOLIC INTEGRATION COEFFICIENTS FOR USE IN PLATE AND SHELL ANALYSES

$\begin{bmatrix} \Gamma \\ 6 \end{bmatrix}$

ROW	1	2	3	4
1	0.	1.0000000E 00	1.0000000E 00	-0.
2	0.	5.0000000E-01	6.6666666E-01	-0.
3	0.	3.3333333E-01	5.0000000E-01	-0.
4	0.	5.0000000E-01	5.0000000E-01	-0.
5	0.	2.5000000E-01	3.3333333E-01	-0.
6	0.	1.6666667E-01	2.5000000E-01	-0.
7	0.	3.3333333E-01	3.3333333E-01	-0.
8	0.	1.6666667E-01	2.2222222E-01	-0.
9	0.	1.1111111E-01	1.6666667E-01	-0.
010	0.	2.5000000E-01	2.5000000E-01	-0.
011	0.	1.2500000E-01	1.6666667E-01	-0.
012	0.	8.3333333E-02	1.2500000E-01	-0.
013	0.	2.5000000E-01	4.0000000E-01	-0.
014	0.	1.2500000E-01	2.0000000E-01	-0.
015	0.	8.3333333E-02	1.3333333E-01	-0.
016	0.	6.2500000E-02	9.9999999E-02	-0.

Contrails

ROW	COLUMN			
	5	6	7	8
1	5.0000000E-01	5.0000000E-01	0.	3.3333333E-01
2	2.5000000E-01	3.3333333E-01	0.	1.6666667E-01
3	1.6666667E-01	2.5000000E-01	0.	1.1111111E-01
4	3.3333333E-01	3.3333333E-01	0.	2.5000000E-01
5	1.6666667E-01	2.2222222E-01	0.	1.2500000E-01
6	1.1111111E-01	1.6666667E-01	0.	8.3333333E-02
7	2.5000000E-01	2.5000000E-01	0.	2.0000000E-01
8	1.2500000E-01	1.6666667E-01	0.	9.9999999E-02
9	8.3333333E-02	1.2500000E-01	0.	6.6666666E-02
10	2.0000000E-01	2.0000000E-01	0.	1.6666667E-01
11	9.9999999E-02	1.3333333E-01	0.	8.3333333E-02
12	6.6666666E-02	9.9999999E-02	0.	5.5555555E-02
13	1.2500000E-01	2.0000000E-01	0.	8.3333333E-02
14	8.3333333E-02	1.3333333E-01	0.	6.2500000E-02
15	6.2500000E-02	9.9999999E-02	0.	4.9999999E-02
16	4.9999999E-02	7.9999999E-02	0.	4.1666666E-02

Contrails

ROW

COLUMN

	9	10	11	12
1	3.3333333E-01	0.	2.5000000E-01	2.5000000E-01
2	2.2222222E-01	0.	1.2500000E-01	1.6666667E-01
3	1.6666667E-01	0.	8.3333333E-02	1.2500000E-01
4	2.5000000E-01	0.	2.0000000E-01	2.0000000E-01
5	1.6666667E-01	0.	9.9999999E-02	1.3333333E-01
6	1.2500000E-01	0.	6.6666666E-02	9.9999999E-02
7	2.0000000E-01	0.	1.6666667E-01	1.6666667E-01
8	1.3333333E-01	0.	8.3333333E-02	1.1111111E-01
9	9.9999999E-02	0.	5.5555555E-02	8.3333333E-02
10	1.6666667E-01	0.	1.4285714E-01	1.4285714E-01
11	1.1111111E-01	0.	7.1428571E-02	9.5238094E-02
12	8.3333333E-02	0.	4.7619047E-02	7.1428571E-02
13	1.3333333E-01	0.	6.2500000E-02	9.9999999E-02
14	9.9999999E-02	0.	4.9999999E-02	7.9999999E-02
15	7.9999999E-02	0.	4.1666666E-02	6.6666666E-02
16	6.6666666E-02	0.	3.5714285E-02	5.7142857E-02

Contrails

ROW	COLUMN			
	13	14	15	16
1	9.9999999E-01	4.9999999E-01	3.3333333E-01	2.5000000E-01
2	7.5000000E-01	3.7500000E-01	2.5000000E-01	1.8750000E-01
3	5.9999999E-01	3.0000000E-01	2.0000000E-01	1.5000000E-01
4	4.9999999E-01	3.3333333E-01	2.5000000E-01	2.0000000E-01
5	3.7500000E-01	2.5000000E-01	1.8750000E-01	1.5000000E-01
6	3.0000000E-01	2.0000000E-01	1.5000000E-01	1.2000000E-01
7	3.3333333E-01	2.5000000E-01	2.0000000E-01	1.6666667E-01
8	2.5000000E-01	1.8750000E-01	1.5000000E-01	1.2500000E-01
9	2.0000000E-01	1.5000000E-01	1.2000000E-01	9.9999999E-02
10	2.5000000E-01	2.0000000E-01	1.6666667E-01	1.4285714E-01
11	1.8750000E-01	1.5000000E-01	1.2500000E-01	1.0714286E-01
12	1.5000000E-01	1.2000000E-01	9.9999999E-02	8.5714284E-02
13	4.9999999E-01	2.5000000E-01	1.6666667E-01	1.2500000E-01
14	2.5000000E-01	1.6666667E-01	1.2500000E-01	9.9999999E-02
15	1.6666667E-01	1.2500000E-01	9.9999999E-02	8.3333333E-02
16	1.2500000E-01	9.9999999E-02	8.3333333E-02	7.1428571E-02

TWO-DIMENSIONAL DIPARABOLIC
INTEGRATION COEFFICIENTS FOR
USE IN PLATE AND SHELL ANALYSES

[5]

ROW	COLUMN	1	2	3	4
2	0.		1.0000000E 00	1.0000000E 00	0.
3	0.		1.0000000E 00	1.3333333E 00	0.
5	0.		5.0000000E-01	5.0000000E-01	0.
6	0.		5.0000000E-01	6.6666666E-01	0.
8	0.		3.3333333E-01	3.3333333E-01	0.
9	0.		3.3333333E-01	4.4444444E-01	0.
11	0.		2.5000000E-01	2.5000000E-01	0.
12	0.		2.5000000E-01	3.3333333E-01	0.
13	0.		1.0000000E 00	1.5000000E 00	0.
14	0.		5.0000000E-01	7.5000000E-01	0.
15	0.		3.3333333E-01	5.0000000E-01	0.
16	0.		2.5000000E-01	3.7500000E-01	0.

Contrails

ROW	COLUMN			
	5	6	7	8
2	5.0000000E-01	5.0000000E-01	0.	3.3333333E-01
3	5.0000000E-01	6.6666666E-01	0.	3.3333333E-01
5	3.3333333E-01	3.3333333E-01	0.	2.5000000E-01
6	3.3333333E-01	4.4444444E-01	0.	2.5000000E-01
8	2.5000000E-01	2.5000000E-01	0.	2.0000000E-01
9	2.5000000E-01	3.3333333E-01	0.	2.0000000E-01
11	2.0000000E-01	2.0000000E-01	0.	1.6666667E-01
12	2.0000000E-01	2.6666667E-01	0.	1.6666667E-01
13	5.0000000E-01	7.5000000E-01	0.	3.3333333E-01
14	3.3333333E-01	5.0000000E-01	0.	2.5000000E-01
15	2.5000000E-01	3.7500000E-01	0.	2.0000000E-01
16	2.0000000E-01	3.0000000E-01	0.	1.6666667E-01

Contrails

ROW	COLUMN			
	9	10	11	12
2	3.3333333E-01	0.	2.5000000E-01	2.5000000E-01
3	4.4444444E-01	0.	2.5000000E-01	3.3333333E-01
5	2.5000000E-01	0.	2.0000000E-01	2.0000000E-01
6	3.3333333E-01	0.	2.0000000E-01	2.6666667E-01
8	2.0000000E-01	0.	1.6666667E-01	1.6666667E-01
9	2.6666667E-01	0.	1.6666667E-01	2.2222222E-01
11	1.6666667E-01	0.	1.4285714E-01	1.4285714E-01
12	2.2222222E-01	0.	1.4285714E-01	1.9047619E-01
13	5.0000000E-01	0.	2.5000000E-01	3.7500000E-01
14	3.7500000E-01	0.	2.0000000E-01	3.0000000E-01
15	3.0000000E-01	0.	1.6666667E-01	2.5000000E-01
16	2.5000000E-01	0.	1.4285714E-01	2.1428571E-01

Contrails

ROW	COLUMN			
	13	14	15	16
2	1.0000000E 00	5.0000000E-01	3.3333333E-01	2.5000000E-01
3	1.5000000E 00	7.5000000E-01	5.0000000E-01	3.7500000E-01
5	5.0000000E-01	3.3333333E-01	2.5000000E-01	2.0000000E-01
6	7.5000000E-01	5.0000000E-01	3.7500000E-01	3.0000000E-01
8	3.3333333E-01	2.5000000E-01	2.0000000E-01	1.6666667E-01
9	5.0000000E-01	3.7500000E-01	3.0000000E-01	2.5000000E-01
11	2.5000000E-01	2.0000000E-01	1.6666667E-01	1.4285714E-01
12	3.7500000E-01	3.0000000E-01	2.5000000E-01	2.1428571E-01
13	1.8000000E 00	8.9999999E-01	5.9999999E-01	4.4999999E-01
14	8.9999999E-01	5.9999999E-01	4.4999999E-01	3.6000000E-01
15	5.9999999E-01	4.4999999E-01	3.6000000E-01	3.0000000E-01
16	4.4999999E-01	3.6000000E-01	3.0000000E-01	2.5714286E-01

TWO-DIMENSIONAL DIPARABOLIC
INTEGRATION COEFFICIENTS FOR
USE IN PLATE AND SHELL ANALYSES

$$[\Gamma_8]$$

ROW	COLUMN			
	1	2	3	4
4	0.	0.	0.	1.0000000E 00
5	0.	0.	0.	5.0000000E-01
6	0.	0.	0.	3.3333333E-01
7	0.	0.	0.	1.0000000E 00
8	0.	0.	0.	5.0000000E-01
9	0.	0.	0.	3.3333333E-01
10	0.	0.	0.	1.0000000E 00
11	0.	0.	0.	5.0000000E-01
12	0.	0.	0.	3.3333333E-01
14	0.	0.	0.	2.5000000E-01
15	0.	0.	0.	2.5000000E-01
16	0.	0.	0.	2.5000000E-01

Contrails

ROW	COLUMN			
	5	6	7	8
4	5.0000000E-01	3.3333333E-01	1.0000000E 00	5.0000000E-01
5	3.3333333E-01	2.5000000E-01	5.0000000E-01	3.3333333E-01
6	2.5000000E-01	2.0000000E-01	3.3333333E-01	2.5000000E-01
7	5.0000000E-01	3.3333333E-01	1.3333333E 00	6.6666666E-01
8	3.3333333E-01	2.5000000E-01	6.6666666E-01	4.4444444E-01
9	2.5000000E-01	2.0000000E-01	4.4444444E-01	3.3333333E-01
10	5.0000000E-01	3.3333333E-01	1.5000000E 00	7.5000000E-01
11	3.3333333E-01	2.5000000E-01	7.5000000E-01	5.0000000E-01
12	2.5000000E-01	2.0000000E-01	5.0000000E-01	3.7500000E-01
14	2.0000000E-01	1.6666667E-01	2.5000000E-01	2.0000000E-01
15	2.0000000E-01	1.6666667E-01	3.3333333E-01	2.6666667E-01
16	2.0000000E-01	1.6666667E-01	3.7500000E-01	3.0000000E-01

Contrails

ROW	COLUMN			
	9	10	11	12
4	3.3333333E-01	1.0000000E 00	5.0000000E-01	3.3333333E-01
5	2.5000000E-01	5.0000000E-01	3.3333333E-01	2.5000000E-01
6	2.0000000E-01	3.3333333E-01	2.5000000E-01	2.0000000E-01
7	4.4444444E-01	1.5000000E 00	7.5000000E-01	5.0000000E-01
8	3.3333333E-01	7.5000000E-01	5.0000000E-01	3.7500000E-01
9	2.6666667E-01	5.0000000E-01	3.7500000E-01	3.0000000E-01
10	5.0000000E-01	1.8000000E 00	8.9999999E-01	5.9999999E-01
11	3.7500000E-01	8.9999999E-01	5.9999999E-01	4.4999999E-01
12	3.0000000E-01	5.9999999E-01	4.4999999E-01	3.6000000E-01
14	1.6666667E-01	2.5000000E-01	2.0000000E-01	1.6666667E-01
15	2.2222222E-01	3.7500000E-01	3.0000000E-01	2.5000000E-01
16	2.5000000E-01	4.4999999E-01	3.6000000E-01	3.0000000E-01

Contrails

ROW		COLUMN			
		13	14	15	16
4	0.		2.5000000E-01	2.5000000E-01	2.5000000E-01
5	0.		2.0000000E-01	2.0000000E-01	2.0000000E-01
6	0.		1.6666667E-01	1.6666667E-01	1.6666667E-01
7	0.		2.5000000E-01	3.3333333E-01	3.7500000E-01
8	0.		2.0000000E-01	2.6666667E-01	3.0000000E-01
9	0.		1.6666667E-01	2.2222222E-01	2.5000000E-01
10	0.		2.5000000E-01	3.7500000E-01	4.4999999E-01
11	0.		2.0000000E-01	3.0000000E-01	3.6000000E-01
12	0.		1.6666667E-01	2.5000000E-01	3.0000000E-01
14	0.		1.4285714E-01	1.4285714E-01	1.4285714E-01
15	0.		1.4285714E-01	1.9047619E-01	2.1428571E-01
16	0.		1.4285714E-01	2.1428571E-01	2.5714286E-01

TWO-DIMENSIONAL DIPARABOLIC
INTEGRATION COEFFICIENTS FOR
USE IN PLATE AND SHELL ANALYSES

[r₉]

ROW

COLUMN

	1	2	3	4
2	0.	0.	0.	5.0000000E-01
3	0.	0.	0.	5.0000000E-01
4	0.	5.0000000E-01	5.0000000E-01	0.
5	0.	2.5000000E-01	3.3333333E-01	2.5000000E-01
6	0.	1.6666666E-01	2.5000000E-01	2.5000000E-01
7	0.	5.0000000E-01	5.0000000E-01	0.
8	0.	2.5000000E-01	3.3333333E-01	1.6666666E-01
9	0.	1.6666666E-01	2.5000000E-01	1.6666666E-01
10	0.	5.0000000E-01	5.0000000E-01	0.
11	0.	2.5000000E-01	3.3333333E-01	1.2500000E-01
12	0.	1.6666666E-01	2.5000000E-01	1.2500000E-01
13	0.	0.	0.	5.0000000E-01
14	0.	1.2500000E-01	2.0000000E-01	2.5000000E-01
15	0.	1.2500000E-01	2.0000000E-01	1.6666666E-01
16	0.	1.2500000E-01	2.0000000E-01	1.2500000E-01

Contrails

ROW	COLUMN			
	5	6	7	8
2	2.5000000E-01	1.6666666E-01	5.0000000E-01	2.5000000E-01
3	3.3333333E-01	2.5000000E-01	5.0000000E-01	3.3333333E-01
4	2.5000000E-01	2.5000000E-01	0.	1.6666666E-01
5	2.5000000E-01	2.5000000E-01	3.3333333E-01	2.5000000E-01
6	2.5000000E-01	2.5000000E-01	3.3333333E-01	2.7777777E-01
7	3.3333333E-01	3.3333333E-01	0.	2.5000000E-01
8	2.5000000E-01	2.7777777E-01	2.5000000E-01	2.5000000E-01
9	2.2222222E-01	2.5000000E-01	2.5000000E-01	2.5000000E-01
10	3.7500000E-01	3.7500000E-01	0.	3.0000000E-01
11	2.5000000E-01	2.9166666E-01	2.0000000E-01	2.5000000E-01
12	2.0833333E-01	2.5000000E-01	2.0000000E-01	2.3333333E-01
13	3.7500000E-01	3.0000000E-01	5.0000000E-01	3.7500000E-01
14	2.5000000E-01	2.5000000E-01	3.3333333E-01	2.9166666E-01
15	2.0833333E-01	2.3333333E-01	2.5000000E-01	2.5000000E-01
16	1.8750000E-01	2.2500000E-01	2.0000000E-01	2.2500000E-01

Contrails

ROW	COLUMN			
	9	10	11	12
2	1.6666666E-01	5.0000000E-01	2.5000000E-01	1.6666666E-01
3	2.5000000E-01	5.0000000E-01	3.3333333E-01	2.5000000E-01
4	1.6666666E-01	0.	1.2500000E-01	1.2500000E-01
5	2.2222222E-01	3.7500000E-01	2.5000000E-01	2.0833333E-01
6	2.5000000E-01	3.7500000E-01	2.9166666E-01	2.5000000E-01
7	2.5000000E-01	0.	2.0000000E-01	2.0000000E-01
8	2.5000000E-01	3.0000000E-01	2.5000000E-01	2.3333333E-01
9	2.5000000E-01	3.0000000E-01	2.6666666E-01	2.5000000E-01
0	3.0000000E-01	0.	2.5000000E-01	2.5000000E-01
11	2.6666666E-01	2.5000000E-01	2.5000000E-01	2.5000000E-01
12	2.5000000E-01	2.5000000E-01	2.5000000E-01	2.5000000E-01
13	3.0000000E-01	5.0000000E-01	3.7500000E-01	3.0000000E-01
14	2.6666666E-01	3.7500000E-01	3.1250000E-01	2.7500000E-01
15	2.5000000E-01	3.0000000E-01	2.7500000E-01	2.6000000E-01
16	2.4000000E-01	2.5000000E-01	2.5000000E-01	2.5000000E-01

Contrails

ROW	COLUMN			
	13	14	15	16
2	0.	1.2500000E-01	1.2500000E-01	1.2500000E-01
3	0.	2.0000000E-01	2.0000000E-01	2.0000000E-01
4	5.0000000E-01	2.5000000E-01	1.6666666E-01	1.2500000E-01
5	3.7500000E-01	2.5000000E-01	2.0833333E-01	1.8750000E-01
6	3.0000000E-01	2.5000000E-01	2.3333333E-01	2.2500000E-01
7	5.0000000E-01	3.3333333E-01	2.5000000E-01	2.0000000E-01
8	3.7500000E-01	2.9166666E-01	2.5000000E-01	2.2500000E-01
9	3.0000000E-01	2.6666666E-01	2.5000000E-01	2.4000000E-01
10	5.0000000E-01	3.7500000E-01	3.0000000E-01	2.5000000E-01
11	3.7500000E-01	3.1250000E-01	2.7500000E-01	2.5000000E-01
12	3.0000000E-01	2.7500000E-01	2.6000000E-01	2.5000000E-01
13	0.	2.5000000E-01	2.5000000E-01	2.5000000E-01
14	2.5000000E-01	2.5000000E-01	2.5000000E-01	2.5000000E-01
15	2.5000000E-01	2.5000000E-01	2.5000000E-01	2.5000000E-01
16	2.5000000E-01	2.5000000E-01	2.5000000E-01	2.5000000E-01

TWO-DIMENSIONAL DIPARABOLIC
INTEGRATION COEFFICIENTS FOR
USE IN PLATE AND SHELL ANALYSES

$[r_{10}]$

ROW

COLUMN

	1	2	3	4
1	0.	0.	0.	1.0000000E 00
2	0.	0.	0.	5.0000000E-01
3	0.	0.	0.	3.3333333E-01
4	0.	0.	0.	5.0000000E-01
5	0.	0.	0.	2.5000000E-01
6	0.	0.	0.	1.6666667E-01
7	0.	0.	0.	3.3333333E-01
8	0.	0.	0.	1.6666667E-01
9	0.	0.	0.	1.1111111E-01
10	0.	0.	0.	2.5000000E-01
11	0.	0.	0.	1.2500000E-01
12	0.	0.	0.	8.3333329E-02
13	0.	0.	0.	2.5000000E-01
14	0.	0.	0.	1.2500000E-01
15	0.	0.	0.	8.3333329E-02
16	0.	0.	0.	6.2500000E-02

Contrails

ROW	COLUMN			
	5	6	7	8
1	5.0000000E-01	3.3333333E-01	1.0000000E 00	5.0000000E-01
2	3.3333333E-01	2.5000000E-01	5.0000000E-01	3.3333333E-01
3	2.5000000E-01	2.0000000E-01	3.3333333E-01	2.5000000E-01
4	2.5000000E-01	1.6666667E-01	6.6666666E-01	3.3333333E-01
5	1.6666667E-01	1.2500000E-01	3.3333333E-01	2.2222222E-01
6	1.2500000E-01	9.9999999E-02	2.2222222E-01	1.6666667E-01
7	1.6666667E-01	1.1111111E-01	5.0000000E-01	2.5000000E-01
8	1.1111111E-01	8.3333329E-02	2.5000000E-01	1.6666667E-01
9	8.3333329E-02	6.6666669E-02	1.6666667E-01	1.2500000E-01
10	1.2500000E-01	8.3333329E-02	4.0000000E-01	2.0000000E-01
11	8.3333329E-02	6.2500000E-02	2.0000000E-01	1.3333333E-01
12	6.2500000E-02	4.9999999E-02	1.3333333E-01	9.9999999E-02
13	2.0000000E-01	1.6666667E-01	2.5000000E-01	2.0000000E-01
14	9.9999999E-02	8.3333329E-02	1.6666667E-01	1.3333333E-01
15	6.6666669E-02	5.5555559E-02	1.2500000E-01	9.9999999E-02
16	4.9999999E-02	4.1666669E-02	9.9999999E-02	7.9999999E-02

TWO-DIMENSIONAL DIPARABOLIC
INTEGRATION COEFFICIENTS FOR
USE IN PLATE AND SHELL ANALYSES

ROW	COLUMN			
	9	10	11	12
1	3.3333333E-01	1.0000000E 00	5.0000000E-01	3.3333333E-01
2	2.5000000E-01	5.0000000E-01	3.3333333E-01	2.5000000E-01
3	2.0000000E-01	3.3333333E-01	2.5000000E-01	2.0000000E-01
4	2.2222222E-01	7.5000000E-01	3.7500000E-01	2.5000000E-01
5	1.6666667E-01	3.7500000E-01	2.5000000E-01	1.8750000E-01
6	1.3333333E-01	2.5000000E-01	1.8750000E-01	1.5000000E-01
7	1.6666667E-01	5.9999999E-01	3.0000000E-01	2.0000000E-01
8	1.2500000E-01	3.0000000E-01	2.0000000E-01	1.5000000E-01
9	9.9999999E-02	2.0000000E-01	1.5000000E-01	1.2000000E-01
10	1.3333333E-01	5.0000000E-01	2.5000000E-01	1.6666667E-01
11	9.9999999E-02	2.5000000E-01	1.6666667E-01	1.2500000E-01
12	7.9999999E-02	1.6666667E-01	1.2500000E-01	9.9999999E-02
13	1.6666667E-01	2.5000000E-01	2.0000000E-01	1.6666667E-01
14	1.1111111E-01	1.8750000E-01	1.5000000E-01	1.2500000E-01
15	8.3333329E-02	1.5000000E-01	1.2000000E-01	9.9999999E-02
16	6.6666669E-02	1.2500000E-01	9.9999999E-02	8.3333329E-02

Contrails

RDW		COLUMN			
		13	14	15	16
1	0.		2.5000000E-01	2.5000000E-01	2.5000000E-01
2	0.		2.0000000E-01	2.0000000E-01	2.0000000E-01
3	0.		1.6666667E-01	1.6666667E-01	1.6666667E-01
4	0.		1.2500000E-01	1.6666667E-01	1.8750000E-01
5	0.		9.9999999E-02	1.3333333E-01	1.5000000E-01
6	0.		8.3333329E-02	1.1111111E-01	1.2500000E-01
7	0.		8.3333329E-02	1.2500000E-01	1.5000000E-01
8	0.		6.6666669E-02	9.9999999E-02	1.2000000E-01
9	0.		5.5555559E-02	8.3333329E-02	9.9999999E-02
10	0.		6.2500000E-02	9.9999999E-02	1.2500000E-01
11	0.		4.9999999E-02	7.9999999E-02	9.9999999E-02
12	0.		4.1666669E-02	6.6666669E-02	8.3333329E-02
13	0.		1.4285714E-01	1.4285714E-01	1.4285714E-01
14	0.		7.1428570E-02	9.5238099E-02	1.0714286E-01
15	0.		4.7619050E-02	7.1428570E-02	8.5714289E-02
16	0.		3.5714290E-02	5.7142860E-02	7.1428570E-02

TWO-DIMENSIONAL DIPARABOLIC
INTEGRATION COEFFICIENTS FOR
USE IN PLATE AND SHELL ANALYSES

$$[r_{ij}]$$

ROW	COLUMN			
	1	2	3	4
2	0.	0.	0.	1.0000000E 00
3	0.	0.	0.	1.0000000E 00
5	0.	0.	0.	5.0000000E-01
6	0.	0.	0.	5.0000000E-01
8	0.	0.	0.	3.3333333E-01
9	0.	0.	0.	3.3333333E-01
11	0.	0.	0.	2.5000000E-01
12	0.	0.	0.	2.5000000E-01
13	0.	0.	0.	1.0000000E 00
14	0.	0.	0.	5.0000000E-01
15	0.	0.	0.	3.3333333E-01
16	0.	0.	0.	2.5000000E-01

Contrails

ROW	COLUMN			
	5	6	7	8
2	5.0000000E-01	3.3333333E-01	1.0000000E 00	5.0000000E-01
3	6.6666666E-01	5.0000000E-01	1.0000000E 00	6.6666666E-01
5	2.5000000E-01	1.6666667E-01	6.6666666E-01	3.3333333E-01
6	3.3333333E-01	2.5000000E-01	6.6666666E-01	4.4444444E-01
8	1.6666667E-01	1.1111111E-01	5.0000000E-01	2.5000000E-01
9	2.2222222E-01	1.6666667E-01	5.0000000E-01	3.3333333E-01
11	1.2500000E-01	8.3333329E-02	4.0000000E-01	2.0000000E-01
12	1.6666667E-01	1.2500000E-01	4.0000000E-01	2.6666667E-01
13	7.5000000E-01	5.9999999E-01	1.0000000E 00	7.5000000E-01
14	3.7500000E-01	3.0000000E-01	6.6666666E-01	5.0000000E-01
15	2.5000000E-01	2.0000000E-01	5.0000000E-01	3.7500000E-01
16	1.8750000E-01	1.5000000E-01	4.0000000E-01	3.0000000E-01

Contrails

ROW	COLUMN			
	9	10	11	12
2	3.3333333E-01	1.0000000E 00	5.0000000E-01	3.3333333E-01
3	5.0000000E-01	1.0000000E 00	6.6666666E-01	5.0000000E-01
5	2.2222222E-01	7.5000000E-01	3.7500000E-01	2.5000000E-01
6	3.3333333E-01	7.5000000E-01	5.0000000E-01	3.7500000E-01
8	1.6666667E-01	5.9999999E-01	3.0000000E-01	2.0000000E-01
9	2.5000000E-01	5.9999999E-01	4.0000000E-01	3.0000000E-01
11	1.3333333E-01	5.0000000E-01	2.5000000E-01	1.6666667E-01
12	2.0000000E-01	5.0000000E-01	3.3333333E-01	2.5000000E-01
13	5.9999999E-01	1.0000000E 00	7.5000000E-01	5.9999999E-01
14	4.0000000E-01	7.5000000E-01	5.6250000E-01	4.4999999E-01
15	3.0000000E-01	5.9999999E-01	4.4999999E-01	3.6000000E-01
16	2.4000000E-01	5.0000000E-01	3.7500000E-01	3.0000000E-01

Contrails

ROW		COLUMN			
		13	14	15	16
2	0.		2.5000000E-01	2.5000000E-01	2.5000000E-01
3	0.		4.0000000E-01	4.0000000E-01	4.0000000E-01
5	0.		1.2500000E-01	1.6666667E-01	1.8750000E-01
6	0.		2.0000000E-01	2.6666667E-01	3.0000000E-01
8	0.		8.3333329E-02	1.2500000E-01	1.5000000E-01
9	0.		1.3333333E-01	2.0000000E-01	2.4000000E-01
11	0.		6.2500000E-02	9.9999999E-02	1.2500000E-01
12	0.		9.9999999E-02	1.6000000E-01	2.0000000E-01
13	0.		5.0000000E-01	5.0000000E-01	5.0000000E-01
14	0.		2.5000000E-01	3.3333333E-01	3.7500000E-01
15	0.		1.6666667E-01	2.5000000E-01	3.0000000E-01
16	0.		1.2500000E-01	2.0000000E-01	2.5000000E-01

Contrails

TWO-DIMENSIONAL DIPARABOLIC INTEGRATION COEFFICIENTS FOR USE IN PLATE AND SHELL ANALYSES

[r_{12}]

ROW	COLUMN			
	1	2	3	4
7	0.	0.	0.	2.0000000E 00
8	0.	0.	0.	1.0000000E 00
9	0.	0.	0.	6.6666666E-01
10	0.	0.	0.	3.0000000E 00
11	0.	0.	0.	1.5000000E 00
12	0.	0.	0.	1.0000000E 00
15	0.	0.	0.	5.0000000E-01
16	0.	0.	0.	7.5000000E-01
ROW	COLUMN			
	5	6	7	8
7	1.0000000E 00	6.6666666E-01	2.0000000E 00	1.0000000E 00
8	6.6666666E-01	5.0000000E-01	1.0000000E 00	6.6666666E-01
9	5.0000000E-01	4.0000000E-01	6.6666666E-01	5.0000000E-01
10	1.5000000E 00	1.0000000E 00	4.0000000E 00	2.0000000E 00
11	1.0000000E 00	7.5000000E-01	2.0000000E 00	1.3333333E 00
12	7.5000000E-01	5.9999999E-01	1.3333333E 00	1.0000000E 00
15	4.0000000E-01	3.3333333E-01	5.0000000E-01	4.0000000E-01
16	5.9999999E-01	5.0000000E-01	1.0000000E 00	7.9999999E-01

Contrails

ROW	COLUMN			
	9	10	11	12
7	6.6666666E-01	2.0000000E 00	1.0000000E 00	6.6666666E-01
8	5.0000000E-01	1.0000000E 00	6.6666666E-01	5.0000000E-01
9	4.0000000E-01	6.6666666E-01	5.0000000E-01	4.0000000E-01
10	1.3333333E 00	4.5000000E 00	2.2500000E 00	1.5000000E 00
11	1.0000000E 00	2.2500000E 00	1.5000000E 00	1.1250000E 00
12	7.9999999E-01	1.5000000E 00	1.1250000E 00	8.9999999E-01
15	3.3333333E-01	5.0000000E-01	4.0000000E-01	3.3333333E-01
16	6.6666666E-01	1.1250000E 00	8.9999999E-01	7.5000000E-01

ROW	COLUMN			
	13	14	15	16
7	0.	5.0000000E-01	5.0000000E-01	5.0000000E-01
8	0.	4.0000000E-01	4.0000000E-01	4.0000000E-01
9	0.	3.3333333E-01	3.3333333E-01	3.3333333E-01
10	0.	7.5000000E-01	1.0000000E 00	1.1250000E 00
11	0.	5.9999999E-01	7.9999999E-01	8.9999999E-01
12	0.	5.0000000E-01	6.6666666E-01	7.5000000E-01
15	0.	2.8571429E-01	2.8571429E-01	2.8571428E-01
16	0.	4.2857143E-01	5.7142857E-01	6.4285713E-01

Contrails

TWO-DIMENSIONAL DIPARABOLIC INTEGRATION COEFFICIENTS FOR USE IN PLATE AND SHELL ANALYSES

$$[\Gamma_{/3}]$$

ROW

COLUMN

	1	2	3	4
3	0.	0.	0.	2.0000000E 00
6	0.	0.	0.	1.0000000E 00
9	0.	0.	0.	6.6666666E-01
12	0.	0.	0.	5.0000000E-01
13	0.	0.	0.	3.0000000E 00
14	0.	0.	0.	1.5000000E 00
15	0.	0.	0.	1.0000000E 00
16	0.	0.	0.	7.5000000E-01

ROW

COLUMN

	5	6	7	8
3	1.0000000E 00	6.6666666E-01	2.0000000E 00	1.0000000E 00
6	5.0000000E-01	3.3333333E-01	1.3333333E 00	6.6666666E-01
9	3.3333333E-01	2.2222222E-01	1.0000000E 00	5.0000000E-01
12	2.5000000E-01	1.6666667E-01	7.9999999E-01	4.0000000E-01
13	2.0000000E 00	1.5000000E 00	3.0000000E 00	2.0000000E 00
14	1.0000000E 00	7.5000000E-01	2.0000000E 00	1.3333333E 00
15	6.6666666E-01	5.0000000E-01	1.5000000E 00	1.0000000E 00
16	5.0000000E-01	3.7500000E-01	1.2000000E 00	7.9999999E-01

Contrails

ROW

COLUMN

	9	10	11	12
3	6.6666666E-01	2.0000000E 00	1.0000000E 00	6.6666666E-01
6	4.4444444E-01	1.5000000E 00	7.5000000E-01	5.0000000E-01
9	3.3333333E-01	1.2000000E 00	5.9999999E-01	4.0000000E-01
12	2.6666667E-01	1.0000000E 00	5.0000000E-01	3.3333333E-01
13	1.5000000E 00	3.0000000E 00	2.0000000E 00	1.5000000E 00
14	1.0000000E 00	2.2500000E 00	1.5000000E 00	1.1250000E 00
15	7.5000000E-01	1.8000000E 00	1.2000000E 00	8.9999999E-01
16	5.9999999E-01	1.5000000E 00	1.0000000E 00	7.5000000E-01

ROW

COLUMN

	13	14	15	16
3	0.	5.0000000E-01	5.0000000E-01	5.0000000E-01
6	0.	2.5000000E-01	3.3333333E-01	3.7500000E-01
9	0.	1.6666667E-01	2.5000000E-01	3.0000000E-01
12	0.	1.2500000E-01	2.0000000E-01	2.5000000E-01
13	0.	1.2000000E 00	1.2000000E 00	1.2000000E 00
14	0.	5.9999999E-01	7.9999999E-01	8.9999999E-01
15	0.	4.0000000E-01	5.9999999E-01	7.2000000E-01
16	0.	3.0000000E-01	4.8000000E-01	5.9999999E-01

Contrails

TWO-DIMENSIONAL DIPARABOLIC INTEGRATION COEFFICIENTS FOR USE IN PLATE AND SHELL ANALYSES

$$\left[\frac{\Gamma}{14} \right]$$

ROW	COLUMN			
	1	2	3	4
5	0.	1.0000000E 00	1.0000000E 00	0.
6	0.	1.0000000E 00	1.3333333E 00	0.
8	0.	1.0000000E 00	1.0000000E 00	0.
9	0.	1.0000000E 00	1.3333333E 00	0.
11	0.	1.0000000E 00	1.0000000E 00	0.
12	0.	1.0000000E 00	1.3333333E 00	0.
14	0.	1.0000000E 00	1.5000000E 00	0.
15	0.	1.0000000E 00	1.5000000E 00	0.
16	0.	1.0000000E 00	1.5000000E 00	0.
ROW	COLUMN			
	5	6	7	8
5	5.0000000E-01	5.0000000E-01	0.	3.3333333E-01
6	5.0000000E-01	6.6666666E-01	0.	3.3333333E-01
8	6.6666666E-01	6.6666666E-01	0.	5.0000000E-01
9	6.6666666E-01	8.8888887E-01	0.	5.0000000E-01
11	7.5000000E-01	7.5000000E-01	0.	5.9999999E-01
12	7.5000000E-01	1.0000000E 00	0.	5.9999999E-01
14	5.0000000E-01	7.5000000E-01	0.	3.3333333E-01
15	6.6666666E-01	1.0000000E 00	0.	5.0000000E-01
16	7.5000000E-01	1.1250000E 00	0.	5.9999999E-01

Contrails

ROW	COLUMN			
	9	10	11	12
5	3.3333333E-01	0.	2.5000000E-01	2.5000000E-01
6	4.4444444E-01	0.	2.5000000E-01	3.3333333E-01
8	5.0000000E-01	0.	4.0000000E-01	4.0000000E-01
9	6.6666666E-01	0.	4.0000000E-01	5.3333332E-01
11	5.9999999E-01	0.	5.0000000E-01	5.0000000E-01
12	7.9999999E-01	0.	5.0000000E-01	6.6666666E-01
14	5.0000000E-01	0.	2.5000000E-01	3.7500000E-01
15	7.5000000E-01	0.	4.0000000E-01	5.9999999E-01
16	8.9999999E-01	0.	5.0000000E-01	7.5000000E-01

ROW	COLUMN			
	13	14	15	16
5	1.0000000E 00	5.0000000E-01	3.3333333E-01	2.5000000E-01
6	1.5000000E 00	7.5000000E-01	5.0000000E-01	3.7500000E-01
8	1.0000000E 00	6.6666666E-01	5.0000000E-01	4.0000000E-01
9	1.5000000E 00	1.0000000E 00	7.5000000E-01	5.9999999E-01
11	1.0000000E 00	7.5000000E-01	5.9999999E-01	5.0000000E-01
12	1.5000000E 00	1.1250000E 00	8.9999999E-01	7.5000000E-01
14	1.8000000E 00	8.9999999E-01	5.9999999E-01	4.4999999E-01
15	1.8000000E 00	1.2000000E 00	8.9999999E-01	7.2000000E-01
16	1.8000000E 00	1.3500000E 00	1.0800000E 00	8.9999999E-01

Contrails

TWO-DIMENSIONAL DIPARABOLIC INTEGRATION COEFFICIENTS FOR USE IN PLATE AND SHELL ANALYSES

$[r_{15}]$

ROW	COLUMN			
	1	2	3	4
1	0.	0.	0.	5.0000000E-01
2	0.	0.	0.	2.5000000E-01
3	0.	0.	0.	1.6666666E-01
4	-5.0000000E-01	-2.5000000E-01	-1.6666666E-01	0.
5	-2.5000000E-01	-1.6666666E-01	-1.2500000E-01	0.
6	-1.6666666E-01	-1.2500000E-01	-9.9999999E-02	0.
7	-5.0000000E-01	-2.5000000E-01	-1.6666666E-01	-1.6666667E-01
8	-2.5000000E-01	-1.6666666E-01	-1.2500000E-01	-8.3333329E-02
9	-1.6666666E-01	-1.2500000E-01	-9.9999999E-02	-5.5555554E-02
10	-5.0000000E-01	-2.5000000E-01	-1.6666666E-01	-2.5000000E-01
11	-2.5000000E-01	-1.6666666E-01	-1.2500000E-01	-1.2500000E-01
12	-1.6666666E-01	-1.2500000E-01	-9.9999999E-02	-8.3333334E-02
13	0.	0.	0.	1.2500000E-01
14	-1.2500000E-01	-9.9999999E-02	-8.3333334E-02	0.
15	-1.2500000E-01	-9.9999999E-02	-8.3333334E-02	-4.1666670E-02
16	-1.2500000E-01	-9.9999999E-02	-8.3333334E-02	-6.2500000E-02

Contrails

ROW	COLUMN			
	5	6	7	8
1	2.5000000E-01	1.6666666E-01	5.0000000E-01	2.5000000E-01
2	1.6666666E-01	1.2500000E-01	2.5000000E-01	1.6666666E-01
3	1.2500000E-01	9.9999999E-02	1.6666666E-01	1.2500000E-01
4	0.	0.	1.6666667E-01	8.3333329E-02
5	0.	0.	8.3333329E-02	5.5555554E-02
6	0.	0.	5.5555554E-02	4.1666670E-02
7	-8.3333329E-02	-5.5555554E-02	0.	0.
8	-5.5555554E-02	-4.1666670E-02	0.	0.
9	-4.1666670E-02	-3.3333330E-02	0.	0.
10	-1.2500000E-01	-8.3333334E-02	-9.9999998E-02	-4.9999999E-02
11	-8.3333334E-02	-6.2500000E-02	-4.9999999E-02	-3.3333335E-02
12	-6.2500000E-02	-4.9999999E-02	-3.3333335E-02	-2.4999999E-02
13	9.9999999E-02	8.3333334E-02	1.2500000E-01	9.9999999E-02
14	0.	0.	4.1666670E-02	3.3333330E-02
15	-3.3333330E-02	-2.7777775E-02	0.	0.
16	-4.9999999E-02	-4.1666665E-02	-2.4999999E-02	-2.0000000E-02

Contrails

ROW	COLUMN			
	9	10	11	12
1	1.6666666E-01	5.0000000E-01	2.5000000E-01	1.6666666E-01
2	1.2500000E-01	2.5000000E-01	1.6666666E-01	1.2500000E-01
3	9.9999999E-02	1.6666666E-01	1.2500000E-01	9.9999999E-02
4	5.5555554E-02	2.5000000E-01	1.2500000E-01	8.3333334E-02
5	4.1666670E-02	1.2500000E-01	8.3333334E-02	6.2500000E-02
6	3.3333330E-02	8.3333334E-02	6.2500000E-02	4.9999999E-02
7	0.	9.9999998E-02	4.9999999E-02	3.3333335E-02
8	0.	4.9999999E-02	3.3333335E-02	2.4999999E-02
9	0.	3.3333335E-02	2.4999999E-02	2.0000000E-02
10	-3.3333335E-02	0.	0.	0.
11	-2.4999999E-02	0.	0.	0.
12	-2.0000000E-02	0.	0.	0.
13	8.3333334E-02	1.2500000E-01	9.9999999E-02	8.3333334E-02
14	2.7777775E-02	6.2500000E-02	4.9999999E-02	4.1666665E-02
15	0.	2.4999999E-02	2.0000000E-02	1.6666665E-02
16	-1.6666665E-02	0.	0.	0.

Contrails

ROW	COLUMN			
	13	14	15	16
1	0.	1.2500000E-01	1.2500000E-01	1.2500000E-01
2	0.	9.9999999E-02	9.9999999E-02	9.9999999E-02
3	0.	8.3333334E-02	8.3333334E-02	8.3333334E-02
4	-1.2500000E-01	0.	4.1666670E-02	6.2500000E-02
5	-9.9999999E-02	0.	3.3333330E-02	4.9999999E-02
6	-8.3333334E-02	0.	2.7777775E-02	4.1666665E-02
7	-1.2500000E-01	-4.1666670E-02	0.	2.4999999E-02
8	-9.9999999E-02	-3.3333330E-02	0.	2.0000000E-02
9	-8.3333334E-02	-2.7777775E-02	0.	1.6666665E-02
10	-1.2500000E-01	-6.2500000E-02	-2.4999999E-02	0.
11	-9.9999999E-02	-4.9999999E-02	-2.0000000E-02	0.
12	-8.3333334E-02	-4.1666665E-02	-1.6666665E-02	0.
13	0.	7.1428570E-02	7.1428570E-02	7.1428570E-02
14	-7.1428570E-02	0.	2.3809525E-02	3.5714284E-02
15	-7.1428570E-02	-2.3809525E-02	0.	1.4285715E-02
16	-7.1428570E-02	-3.5714284E-02	-1.4285715E-02	0.

Contrails

TWO-DIMENSIONAL DIPARABOLIC INTEGRATION COEFFICIENTS FOR USE IN PLATE AND SHELL ANALYSES

$[r_{16}]$

ROW

COLUMN

	1	2	3	4
1	0.	5.0000000E-01	5.0000000E-01	0.
2	-5.0000000E-01	0.	1.6666667E-01	-2.5000000E-01
3	-5.0000000E-01	-1.6666667E-01	0.	-2.5000000E-01
4	0.	2.5000000E-01	2.5000000E-01	0.
5	-2.5000000E-01	0.	8.3333333E-02	-1.6666667E-01
6	-2.5000000E-01	-8.3333333E-02	0.	-1.6666667E-01
7	0.	1.6666667E-01	1.6666667E-01	0.
8	-1.6666667E-01	0.	5.5555555E-02	-1.2500000E-01
9	-1.6666667E-01	-5.5555555E-02	0.	-1.2500000E-01
10	0.	1.2500000E-01	1.2500000E-01	0.
11	-1.2500000E-01	0.	4.1666666E-02	-9.9999999E-02
12	-1.2500000E-01	-4.1666666E-02	0.	-9.9999999E-02
13	-4.9999999E-01	-2.5000000E-01	-9.9999998E-02	-2.5000000E-01
14	-2.5000000E-01	-1.2500000E-01	-4.9999999E-02	-1.6666667E-01
15	-1.6666667E-01	-8.3333331E-02	-3.3333333E-02	-1.2500000E-01
16	-1.2500000E-01	-6.2500000E-02	-2.4999999E-02	-9.9999999E-02

Contrails

ROW	COLUMN			
	5	6	7	8
1	2.5000000E-01	2.5000000E-01	0.	1.6666667E-01
2	0.	8.3333333E-02	-1.6666667E-01	0.
3	-8.3333333E-02	0.	-1.6666667E-01	-5.5555555E-02
4	1.6666667E-01	1.6666667E-01	0.	1.2500000E-01
5	0.	5.5555555E-02	-1.2500000E-01	0.
6	-5.5555555E-02	0.	-1.2500000E-01	-4.1666666E-02
7	1.2500000E-01	1.2500000E-01	0.	9.9999999E-02
8	0.	4.1666666E-02	-9.9999999E-02	0.
9	-4.1666666E-02	0.	-9.9999999E-02	-3.3333333E-02
10	9.9999999E-02	9.9999999E-02	0.	8.3333333E-02
11	0.	3.3333333E-02	-8.3333333E-02	0.
12	-3.3333333E-02	0.	-8.3333333E-02	-2.7777778E-02
13	-1.2500000E-01	-4.9999999E-02	-1.6666667E-01	-8.3333331E-02
14	-8.3333331E-02	-3.3333333E-02	-1.2500000E-01	-6.2500000E-02
15	-6.2500000E-02	-2.4999999E-02	-9.9999999E-02	-4.9999999E-02
16	-4.9999999E-02	-2.0000000E-02	-8.3333333E-02	-4.1666666E-02

Contrails

ROW	COLUMN			
	9	10	11	12
1	1.6666667E-01	0.	1.2500000E-01	1.2500000E-01
2	5.5555555E-02	-1.2500000E-01	0.	4.1666666E-02
3	0.	-1.2500000E-01	-4.1666666E-02	0.
4	1.2500000E-01	0.	9.9999999E-02	9.9999999E-02
5	4.1666666E-02	-9.9999999E-02	0.	3.3333333E-02
6	0.	-9.9999999E-02	-3.3333333E-02	0.
7	9.9999999E-02	0.	8.3333333E-02	8.3333333E-02
8	3.3333333E-02	-8.3333333E-02	0.	2.7777778E-02
9	0.	-8.3333333E-02	-2.7777778E-02	0.
10	8.3333333E-02	0.	7.1428571E-02	7.1428571E-02
11	2.7777778E-02	-7.1428571E-02	0.	2.3809524E-02
12	0.	-7.1428571E-02	-2.3809524E-02	0.
13	-3.3333333E-02	-1.2500000E-01	-6.2500000E-02	-2.4999999E-02
14	-2.4999999E-02	-9.9999999E-02	-4.9999999E-02	-2.0000000E-02
15	-2.0000000E-02	-8.3333333E-02	-4.1666666E-02	-1.6666667E-02
16	-1.6666667E-02	-7.1428571E-02	-3.5714285E-02	-1.4285714E-02

Contrails

ROW	COLUMN			
	13	14	15	16
1	4.9999999E-01	2.5000000E-01	1.6666667E-01	1.2500000E-01
2	2.5000000E-01	1.2500000E-01	8.3333331E-02	6.2500000E-02
3	9.9999998E-02	4.9999999E-02	3.3333333E-02	2.4999999E-02
4	2.5000000E-01	1.6666667E-01	1.2500000E-01	9.9999999E-02
5	1.2500000E-01	8.3333331E-02	6.2500000E-02	4.9999999E-02
6	4.9999999E-02	3.3333333E-02	2.4999999E-02	2.0000000E-02
7	1.6666667E-01	1.2500000E-01	9.9999999E-02	8.3333333E-02
8	8.3333331E-02	6.2500000E-02	4.9999999E-02	4.1666666E-02
9	3.3333333E-02	2.4999999E-02	2.0000000E-02	1.6666667E-02
10	1.2500000E-01	9.9999999E-02	8.3333333E-02	7.1428571E-02
11	6.2500000E-02	4.9999999E-02	4.1666666E-02	3.5714285E-02
12	2.4999999E-02	2.0000000E-02	1.6666667E-02	1.4285714E-02

Contrails

TWO-DIMENSIONAL DIPARABOLIC INTEGRATION COEFFICIENTS FOR USE IN PLATE AND SHELL ANALYSES

$[\Gamma_{17}]$

ROW		1	2	3	4
4	0.		1.0000000E 00	1.0000000E 00	0.
5	0.		5.0000000E-01	6.6666666E-01	0.
6	0.		3.3333333E-01	5.0000000E-01	0.
7	0.		1.0000000E 00	1.0000000E 00	0.
8	0.		5.0000000E-01	6.6666666E-01	0.
9	0.		3.3333333E-01	5.0000000E-01	0.
10	0.		1.0000000E 00	1.0000000E 00	0.
11	0.		5.0000000E-01	6.6666666E-01	0.
12	0.		3.3333333E-01	5.0000000E-01	0.
14	0.		2.5000000E-01	4.0000000E-01	0.
15	0.		2.5000000E-01	4.0000000E-01	0.
16	0.		2.5000000E-01	4.0000000E-01	0.

Contrails

ROW	COLUMN			
	5	6	7	8
4	5.0000000E-01	5.0000000E-01	0.	3.3333333E-01
5	2.5000000E-01	3.3333333E-01	0.	1.6666667E-01
6	1.6666667E-01	2.5000000E-01	0.	1.1111111E-01
7	6.6666666E-01	6.6666666E-01	0.	5.0000000E-01
8	3.3333333E-01	4.4444444E-01	0.	2.5000000E-01
9	2.2222222E-01	3.3333333E-01	0.	1.6666667E-01
10	7.5000000E-01	7.5000000E-01	0.	5.9999999E-01
11	3.7500000E-01	5.0000000E-01	0.	3.0000000E-01
12	2.5000000E-01	3.7500000E-01	0.	2.0000000E-01
14	1.2500000E-01	2.0000000E-01	0.	8.3333329E-02
15	1.6666667E-01	2.6666667E-01	0.	1.2500000E-01
16	1.8750000E-01	3.0000000E-01	0.	1.5000000E-01

Contrails

ROW	COLUMN			
	9	10	11	12
4	3.3333333E-01	0.	2.5000000E-01	2.5000000E-01
5	2.2222222E-01	0.	1.2500000E-01	1.6666667E-01
6	1.6666667E-01	0.	8.3333329E-02	1.2500000E-01
7	5.0000000E-01	0.	4.0000000E-01	4.0000000E-01
8	3.3333333E-01	0.	2.0000000E-01	2.6666667E-01
9	2.5000000E-01	0.	1.3333333E-01	2.0000000E-01
10	5.9999999E-01	0.	5.0000000E-01	5.0000000E-01
11	4.0000000E-01	0.	2.5000000E-01	3.3333333E-01
12	3.0000000E-01	0.	1.6666667E-01	2.5000000E-01
14	1.3333333E-01	0.	6.2500000E-02	9.9999999E-02
15	2.0000000E-01	0.	9.9999999E-02	1.6000000E-01
16	2.4000000E-01	0.	1.2500000E-01	2.0000000E-01

Contrails

ROW

COLUMN

	13	14	15	16
4	1.0000000E 00	5.0000000E-01	3.3333333E-01	2.5000000E-01
5	7.5000000E-01	3.7500000E-01	2.5000000E-01	1.8750000E-01
6	5.9999999E-01	3.0000000E-01	2.0000000E-01	1.5000000E-01
7	1.0000000E 00	6.6666666E-01	5.0000000E-01	4.0000000E-01
8	7.5000000E-01	5.0000000E-01	3.7500000E-01	3.0000000E-01
9	5.9999999E-01	4.0000000E-01	3.0000000E-01	2.4000000E-01
10	1.0000000E 00	7.5000000E-01	5.9999999E-01	5.0000000E-01
11	7.5000000E-01	5.6250000E-01	4.4999999E-01	3.7500000E-01
12	5.9999999E-01	4.4999999E-01	3.6000000E-01	3.0000000E-01
14	5.0000000E-01	2.5000000E-01	1.6666667E-01	1.2500000E-01
15	5.0000000E-01	3.3333333E-01	2.5000000E-01	2.0000000E-01
16	5.0000000E-01	3.7500000E-01	3.0000000E-01	2.5000000E-01

APPENDIX V

GLOSSARY OF TERMS
USED IN THE TEXT

Contrails

MATRIX NOTATIONS

$[]$	rectangular or square matrix
$\{ \}$	column matrix
$\{ \}'$	row matrix
$\lceil \rceil$	diagonal matrix
$[]'$	matrix transpose
$[]^{-1}$	matrix inverse
$[0], \{0\}$	null matrix
$\lceil 1 \rceil$	unity matrix

DEFINITION OF TERMS IN THE TEXT

$(\mathbb{I}, \mathbb{J}, \mathbb{K})$	inertial set of right-handed, orthogonal, unit vectors
(X, y, z)	Lagrangian particle variables
(ξ, η, ζ)	Eulerian variables for a particle
\mathbb{R}	position vector for the x-y-z particle at time, t
$\mathbb{V} = \frac{\delta \mathbb{R}}{\delta t}$	particle velocity
$\mathbb{a} = \frac{\delta^2 \mathbb{R}}{\delta t^2}$	particle acceleration
ρ	density
\mathbb{P}	body force
Σ	stress dyadic
$\sigma_{ij}, \sigma_{xx}, \sigma_{xy}, \sigma_{\mu\mu}, \sigma_{\mu\kappa}$	various notations for stress components
u	specific internal energy
ν	specific internal dissipation function
U	total internal energy
R	Rayleigh's dissipation function
T	total kinetic energy
ψ	potential of body forces

Contrails

V	total potential of body forces
λ_i	Lagrange's undetermined multipliers
$p_i, i=1,2,\dots,N; \{p\}$	generalized coordinates
[A]	inertia matrix referred to p_i
[K]	stiffness matrix referred to p_i
P_i	generalized forces corresponding to p_i
[E]	influence matrix referred to p_i
[B]	damping matrix corresponding to p_i
$\{\varphi\}_i$	vibration mode
[φ]	modal matrix
ω_i	vibration frequency
λ_i	vibration eigenvalue
[L]	generic notation for coefficients in linear constraints expressed in implicit form
[S]	transformation matrix which constrains rigid body motion
[φ_r]	rigid body modal matrix
[r]	rigid body "sweeping" matrix
[r][E][r]	free body influence coefficients
[G(t)]	Green's function
$q_i, \{q\}$	generic notation for more specialized generalized coordinates, modal coordinates or internal coordinates (Section 5.1.1)
[M]	inertia matrix referred to q_i
[F]	stiffness matrix referred to q_i
Q_i	generalized forces corresponding to q_i
[G]	influence matrix referred to Q_i
[R]	damping matrix corresponding to q_i
$\{\pi\}_i$	vibration mode in terms of a set of q_i 's

Contrails

- [π] modal matrix for q_i 's
- ζ_i modal damping factor
- P displacement vector for x-y-z particle
- $h_i = \frac{\partial P}{\partial p_i} \Big|_{p_1=p_2=\dots=p_n=0}$ generalized Rayleigh-Ritz functions, sometimes called "generalized displacements" corresponding to the generalized coordinates.
- (ξ, η) local, non-dimensional, particle coordinates used in interpolation methods
- [ζ]_i interpolation coefficients for the i th region
- [Λ] aerodynamic influence coefficients corresponding to p_i
- [Δ] streamwise "differentiation" matrix
- ξ rigid body longitudinal translation coordinate
- ζ rigid body lateral translation coordinate
- θ rigid body pitch coordinate
- τ control coordinate
- [R] generic notation for transformation from external loads to internal loads
- [N] axial load coefficient matrix referred to p_i
- [L_a], [L_r], [L_o] quasi-steady aerodynamic matrices referred to p_i
- [H], [H_o] thrust force matrices referred to p_i
- [C_a], [C_r], [C_o] quasi-steady aerodynamic matrices referred to q_i
- { ψ_r }, { ψ_s }, { ψ_o }, { ψ_z } unit, orthogonal, rigid body modes.
- [$C(\dot{M}_o, M_o)$] general unsteady aerodynamic matrix referred to q_i
- [N] generic notation for coefficient matrix in the "standard" eigenvalue problem
- R position vector for the center of mass
- $V = \frac{dR}{dt}$ velocity of center of mass
- L_i , {L} generic notation for internal loads, stress resultants, stresses, or "member" loads

Contrails

- $(\hat{i}, \hat{j}, \hat{k})$ body set of right-handed, orthogonal, unit vectors
- Ω angular velocity of $(\hat{i}, \hat{j}, \hat{k})$ reference system
- \mathbf{F} total force
- \mathbf{G} total moment of forces
- \mathbf{H} total angular momentum
- $[\mathbf{T}_0]$ generic form of geometric transformations used in the method of modal coupling
- $[\Phi]$ modal matrix in terms of system generalized coordinates
- $(\xi, \eta, \zeta, \varphi, \theta, \psi, \mu, \nu, \lambda)$ rigid body generalized coordinates
- (ξ, η, ζ) inertial coordinates of center of mass
- (φ, θ, ψ) Euler angles for $(\hat{i}, \hat{j}, \hat{k})$ reference system
- (μ, ν, λ) primary control displacements

GENERAL MATHEMATICAL NOTATIONS

- $\int () dV$ volume integration
- $\oint () \cdot dS$ closed surface integral
- $\delta ()$ virtual change or variation
- $\bar{f}(s) = \int_0^{\infty} f(t) e^{-st} dt$ Laplace transform
- $\delta(t)$ Dirac's "delta" function
- $H(t)$ Heaviside's unit step function
- $f(t) = \int_{-\infty}^{\infty} \bar{f}(\omega) e^{i\omega t} d\omega$
 $\bar{f}(\omega) = \frac{1}{2\pi} \int_{-\infty}^{\infty} f(t) e^{-i\omega t} dt$
- } Fourier transform pair

APPENDIX VI

THE GILL-RUNGE-KUTTA SCHEME OF
NUMERICAL INTEGRATION

Contrails

Contrails

1.0 COMPUTER SUBROUTINE FOR NUMERICAL INTEGRATION

The method for the numerical integration of ordinary differential equations described here is the method of Runge-Kutta which has been adapted for use on a digital computer by Stanley Gill.

The numerical integration of equations of the type

$$\frac{dy}{dx} = f(x, y) \quad (\text{VI-1})$$

is accomplished by the Runge-Kutta method as follows.

Let the interval be of length h so that the range of x is divided by the points x_0, x_1, \dots where

$$\begin{aligned} x_1 &= x_0 + h \\ x_2 &= x_0 + 2h \\ &\vdots \\ x_n &= x_0 + nh \end{aligned} \quad (\text{VI-2})$$

Each increment Δy of y is calculated as follows

$$\Delta y_n = \frac{1}{6} (k_1 + 2k_2 + 2k_3 + k_4) \quad (\text{VI-3})$$

where

$$\begin{aligned} k_1 &= h f(x_n, y_n) \\ k_2 &= h f(x_n + \frac{1}{2}h, y_n + \frac{1}{2}k_1) \\ k_3 &= h f(x_n + \frac{1}{2}h, y_n + \frac{1}{2}k_2) \\ k_4 &= h f(x_n + h, y_n + k_3) \end{aligned} \quad (\text{VI-4})$$

A weighted average of the four k 's affords a good estimate of Δy and the error is of the order of h^2 , for a given interval*.

If Equation VI-1 is of the form

$$\frac{dy}{dx} = f(x) \quad (\text{VI-5})$$

the Runge-Kutta method reduces to Simpson's rule. In this case Δy is accurately given by

$$\Delta y = \int_{x_n}^{x_{n+1}} f(x) dx \quad (\text{VI-6})$$

*The derivation of the above formulas is given in Ince, E. L., Ordinary Differential Equations, Dover, 1944, pp. 540 to 547. See also Lery, H. and Baggott, E. A., Numerical Solutions to Differential Equations, Watts and Co. (London) 1934, pp. 96 to 110.

Contrails

The Runge-Kutta formulas give

$$\Delta y = \frac{h}{6} (f(x_n) + 2f(x_n + \frac{h}{2}) + 2f(x_n + \frac{h}{2}) + f(x_n + h)) \quad (\text{VI-7})$$
$$= \frac{h}{12} (f(x_n) + 4f(x_n + \frac{h}{2}) + f(x_n + h))$$

which is seen to be the Simpson rule approximation for the integral in VI-6.

The computation form displayed below is probably the most suitable if a hand calculator is being used for solution. The calculation of Δy is broken up into the following steps:

$$y'_{n_1} = f(x_{n_1}, y_{n_1}) \quad (\text{VI-8})$$
$$x_{n_2} = x_n + h/2$$
$$y_{n_2} = y_n + h/2 y'_{n_1}$$

$$y'_{n_2} = f(x_{n_2}, y_{n_2}) \quad (\text{VI-9})$$
$$x_{n_3} = x_n + h/2$$
$$y_{n_3} = y_n + h/2 y'_{n_2}$$

$$y'_{n_3} = f(x_{n_3}, y_{n_3}) \quad (\text{VI-10})$$
$$x_{n_4} = x_n + h$$
$$y_{n_4} = y_n + h y'_{n_3}$$

Finally

$$y'_{n_4} = f(x_{n_4}, y_{n_4}) \quad (\text{VI-11})$$

$$\Delta y_n = \frac{h}{6} (y'_{n_1} + 2y'_{n_2} + 2y'_{n_3} + y'_{n_4}) \quad (\text{VI-12})$$

$$y_{n+1} = y_n + \Delta y_n$$

If it is assumed that a differential equation can be solved for the derivative of highest order in the dependent variable, it is seen that the Runge-Kutta Equations VI-3 are applicable to higher order equations since these may be reduced to a system of first order equations.

The Runge-Kutta method of integration has several desirable features which may be summarized as follows.

1) This method is generally considered to have good convergence qualities. Forward integration and iteration procedures can sometimes be unstable so that a calculated solution oscillates with rapidly increasing amplitude about the true solution. The Runge-Kutta method does not seem to be so susceptible to this difficulty.

Contrails

2) The Runge-Kutta method allows the use of fairly large intervals compared to other methods of numerical integration.

3) Each integration interval is complete within itself, i.e., the only quantities necessary to proceed from one step to the next are those which would also be supplied as initial conditions to start the integration procedure. This feature allows a change of the interval size at any point. The integration may also be re-started at any point with ease.

The Gill modification to the Runge-Kutta process produces identical results but simplifies the labor involved when a system of simultaneous differential equations are to be integrated on a digital computer*. The Gill-Runge-Kutta process is defined by the following equations. In these relations each equation contains terms defined by preceding equations.

	Equivalent Fortran Statement Number
(See Table 36)	
$k_{n0} = h f_n (y_{n0}, y_{n0} \dots)$	40
$\pi_{n1} = \frac{1}{2} k_{n0} - \omega q_{n0}$	70
$y_{n1} = y_{n0} + \pi_{n1}$	80
$q_{n1} = q_{n0} + 3\pi_{n1} - \frac{1}{2} k_{n0}$	90
$k_{n1} = h f_n (y_{n1}, y_{n1} \dots)$	120
$\pi_{n2} = (1 - \sqrt{2}) (k_{n1} - q_{n1})$	140
$y_{n2} = y_{n1} + \pi_{n2} - (1 - \sqrt{2}) k_{n1}$	150
$q_{n2} = q_{n1} + 3\pi_{n2}$	160
$k_{n2} = h f_n (y_{n2}, y_{n2} \dots)$	190
$\pi_{n3} = (1 + \sqrt{2}) (k_{n2} - q_{n2})$	210
$y_{n3} = y_{n2} + \pi_{n3}$	220
$q_{n3} = q_{n2} + 3\pi_{n3} - (1 + \sqrt{2}) k_{n2}$	230
$k_{n3} = h f_n (y_{n3}, y_{n3} \dots)$	260
$\pi_{n4} = \frac{1}{6} (k_{n3} - 2q_{n3})$	280
$y_{n4} = y_{n3} + \pi_{n4}$	290
$q_{n4} = q_{n3} + 3\pi_{n4} - \frac{1}{2} k_{n3}$	300

*Wheeler, D. J., and Gill, S., The Preparation of Programs for an Electronic Digital Computer Addison-Wesley, 1951.

Contrails

The coefficient ω appearing in the expression for Γ_n , is not critical. The best value is actually 1, as it simplifies the program.

Table 36 is an IBM 7090 Fortran II listing of the integration scheme used in the results documented in this report. It is called Subroutine RK (Runge-Kutta). The definitions below will be helpful in its interpretation.

Subroutine DYDXS - Forms an expression for derivatives

Subroutine INPUT - reads data in

Subroutine OUTPUT - outputs results of integration

Y(I) = dependent variables

DYDX(I) = time derivatives of dependent variables

Y(1) = independent variable

DYDX(1) = 1.0

P(1) = integration step size

2.0 INTEGRATION OF THE GENERAL LINEAR TRANSIENT RESPONSE EQUATIONS

The Runge-Kutta integration can be used to obtain time-histories of transient stresses and displacements by solving a very general set of equations which arise when the assumption of small displacements is made. The form of the differential equation is:

$$[M]\ddot{q} + [R]\dot{q} + [F]q = \{q_0\} + \left[\frac{\partial Q}{\partial F}\right]F(t) \quad (\text{VI-13})$$

with the stresses and/or internal loads given by the general expression:

$$\{L\} = \{L_0\} + \left[\frac{\partial L}{\partial q}\right]q + \left[\frac{\partial L}{\partial \dot{q}}\right]\dot{q} + \left[\frac{\partial L}{\partial \ddot{q}}\right]\ddot{q} + \left[\frac{\partial L}{\partial F}\right]F(t) \quad (\text{VI-14})$$

and the displacements and accelerations given by

$$\{p\} = [\varphi]\{q\} \quad (\text{VI-15})$$

$$\{\ddot{p}\} = [\varphi]\{\ddot{q}\} \quad (\text{VI-16})$$

In these expressions, the following coefficient matrices are assumed to be independent of time and are supplied as input to the numerical integration scheme:

Contrails

[M], the mass matrix

[R], dissipation matrix for the structure and the damping of quasi-steady aerodynamic forces

[F], structural stiffness matrix and quasi-steady aerodynamic stiffness

$\{Q_0\}$, $[\frac{\partial Q}{\partial F}]$ constant coefficients in time dependent generalized forces

$\{L_0\}$, $[\frac{\partial L}{\partial q}]$, $[\frac{\partial L}{\partial \dot{q}}]$, $[\frac{\partial L}{\partial \ddot{q}}]$, $[\frac{\partial L}{\partial F}]$

constant coefficients relating stresses to time dependent quantities

$[\psi]$, relation of displacements to modal generalized coordinates

Also supplied as input, is a table of functions of time, $F_i(t)$, used to describe the transient generalized forces.

**TABLE 36
FORTRAN SOURCE PROGRAM LISTING OF RUNGE-KUTTA SUBROUTINE**

```

* LIST
* SYMBOL TABLE
CRK
      SUBROUTINE RK
      COMMON VAR
      DIMENSION VAR(24000),DYDX(75),Y(75),Q(75),D(75),
1 NTEGER(225),P(23400)
      EQUIVALENCE (VAR(1),Y(1)),(VAR(76),DYDX(1)),
1 (VAR(151),Q(1)),(VAR(301),D(1)),(VAR(376),NTEGER(1)),
2 (VAR(601),P(1)),(NTEGER(6),N)
C LOAD INPUT DATA INTO MACHINE.
10 CALL INPUT
C CALCULATE THE DELTAY(J) AT Y(1) = 0.0.
20 CALL DYDXS
30 DO 40 I = 1,N
40 D(I) = DYDX(I)*P(1)
C DETERMINE THE OUTPUT OF THE INTEGRATION.
50 CALL OUTPUT
C CALCULATE THE Y(J) AT Y(1) = 0.0.
60 DO 90 J = 1,N
70 R = .5*(D(J) - Q(J))
80 Y(J) = Y(J) + R
90 Q(J) = Q(J) + 3.0*R - .5*D(J)
C CALCULATE THE DELTAY(J) AT Y(1) = HALF STEP SIZE.
100 CALL DYDXS
110 DO 120 I = 1,N
120 D(I) = DYDX(I)*P(1)
C CALCULATE THE Y(J) AT Y(1) = HALF STEP SIZE.
130 DO 160 J = 1,N
140 R = .292893219*(D(J) - Q(J))
150 Y(J) = Y(J) + R
160 Q(J) = Q(J) + 3.0*R - .292893219*D(J)
C CALCULATE THE DELTAY(J) AT Y(1) = HALF STEP SIZE AGAIN.
170 CALL DYDXS
180 DO 190 I = 1,N
190 D(I) = DYDX(I)*P(1)
C CALCULATE THE Y(J) AT Y(1) = HALF STEP SIZE AGAIN.
200 DO 230 J = 1,N
210 R = 1.70710678*(D(J) - Q(J))
220 Y(J) = Y(J) + R
230 Q(J) = Q(J) + 3.0*R - 1.70710678*D(J)
C CALCULATE THE DELTAY(J) AT Y(1) = STEP SIZE.
240 CALL DYDXS
250 DO 260 I = 1,N
260 D(I) = DYDX(I)*P(1)
C CALCULATE THE Y(J) AT Y(1) = STEP SIZE.
270 DO 300 J = 1,N
280 R = .1666666667*(D(J) - 2.0*Q(J))
290 Y(J) = Y(J) + R
300 Q(J) = Q(J) + 3.0*R - .5*D(J)
C PROCEED TO THE NEXT INTEGRATION STEP.
310 NGO = 1
320 GO TO (20,330),NGO
330 RETURN
      END
0055

```

DOCUMENT CONTROL DATA - R&D

(Security classification of title, body of abstract and indexing annotation must be entered when the overall report is classified)

1. ORIGINATING ACTIVITY (Corporate author) LTV Astronautics Division Ling-Temco-Vought, Inc.		2a. REPORT SECURITY CLASSIFICATION Unclassified	
		2b. GROUP	
3. REPORT TITLE Methods in Structural Dynamics for Thin Shell Clustered Launch Vehicles			
4. DESCRIPTIVE NOTES (Type of report and inclusive dates)			
5. AUTHOR(S) (Last name, first name, initial) Keith, J. Stuart, Lincoln, J. W.			
6. REPORT DATE April 1965		7a. TOTAL NO. OF PAGES 736	7b. NO. OF REFS 36
8a. CONTRACT OR GRANT NO. AF33(657)-9146		8a. ORIGINATOR'S REPORT NUMBER(S) FDL-TDR-64-105	
b. PROJECT NO. 1370		8b. OTHER REPORT NO(S) (Any other numbers that may be assigned this report)	
c. Task No. 137008			
d.			
10. AVAILABILITY/LIMITATION NOTICES			
11. SUPPLEMENTARY NOTES		12. SPONSORING MILITARY ACTIVITY AF Flight Dynamics Laboratory	
13. ABSTRACT <p>A general methodology in Structural Dynamics based on the use of generalized coordinates is presented. These general methods are demonstrated by analysis of some of the problems of slender, conventional, launch vehicles. Applications of the general methodology are also given for complex configurations employing thin shell tanks in clustered arrangements. The methods of structural analysis and vibration analysis that are presented are not restricted to any particular geometry and apply to any complex redundantly coupled structure.</p> <p>To further demonstrate the general methods, a vibration analysis of the clustered Saturn I launch vehicle is presented.</p>			

14. KEY WORDS	LINK A		LINK B		LINK C	
	ROLE	WT	ROLE	WT	ROLE	WT
Clustered Tanks Launch Vehicle Dynamics Structural Analysis Thin Shell Dynamics						

INSTRUCTIONS

1. **ORIGINATING ACTIVITY:** Enter the name and address of the contractor, subcontractor, grantee, Department of Defense activity or other organization (*corporate author*) issuing the report.

2a. **REPORT SECURITY CLASSIFICATION:** Enter the overall security classification of the report. Indicate whether "Restricted Data" is included. Marking is to be in accordance with appropriate security regulations.

2b. **GROUP:** Automatic downgrading is specified in DoD Directive 5200.10 and Armed Forces Industrial Manual. Enter the group number. Also, when applicable, show that optional markings have been used for Group 3 and Group 4 as authorized.

3. **REPORT TITLE:** Enter the complete report title in all capital letters. Titles in all cases should be unclassified. If a meaningful title cannot be selected without classification, show title classification in all capitals in parenthesis immediately following the title.

4. **DESCRIPTIVE NOTES:** If appropriate, enter the type of report, e.g., interim, progress, summary, annual, or final. Give the inclusive dates when a specific reporting period is covered.

5. **AUTHOR(S):** Enter the name(s) of author(s) as shown on or in the report. Enter last name, first name, middle initial. If military, show rank and branch of service. The name of the principal author is an absolute minimum requirement.

6. **REPORT DATE:** Enter the date of the report as day, month, year, or month, year. If more than one date appears on the report, use date of publication.

7a. **TOTAL NUMBER OF PAGES:** The total page count should follow normal pagination procedures, i.e., enter the number of pages containing information.

7b. **NUMBER OF REFERENCES:** Enter the total number of references cited in the report.

8a. **CONTRACT OR GRANT NUMBER:** If appropriate, enter the applicable number of the contract or grant under which the report was written.

8b, 8c, & 8d. **PROJECT NUMBER:** Enter the appropriate military department identification, such as project number, subproject number, system numbers, task number, etc.

9a. **ORIGINATOR REPORT NUMBER(S):** Enter the official report number by which the document will be identified and controlled by the originating activity. This number must be unique to this report.

9b. **OTHER REPORT NUMBER(S):** If the report has been assigned any other report numbers (*either by the originator or by the sponsor*), also enter this number(s).

10. **AVAILABILITY/LIMITATION NOTICES:** Enter any limitations on further dissemination of the report, other than those

imposed by security classification, using standard statements such as:

- (1) "Qualified requesters may obtain copies of this report from DDC."
- (2) "Foreign announcement and dissemination of this report by DDC is not authorized."
- (3) "U. S. Government agencies may obtain copies of this report directly from DDC. Other qualified DDC users shall request through _____."
- (4) "U. S. military agencies may obtain copies of this report directly from DDC. Other qualified users shall request through _____."
- (5) "All distribution of this report is controlled. Qualified DDC users shall request through _____."

If the report has been furnished to the Office of Technical Services, Department of Commerce, for sale to the public, indicate this fact and enter the price, if known.

11. **SUPPLEMENTARY NOTES:** Use for additional explanatory notes.

12. **SPONSORING MILITARY ACTIVITY:** Enter the name of the departmental project office or laboratory sponsoring (*paying for*) the research and development. Include address.

13. **ABSTRACT:** Enter an abstract giving a brief and factual summary of the document indicative of the report, even though it may also appear elsewhere in the body of the technical report. If additional space is required, a continuation sheet shall be attached.

It is highly desirable that the abstract of classified reports be unclassified. Each paragraph of the abstract shall end with an indication of the military security classification of the information in the paragraph, represented as (TS), (S), (C), or (U).

There is no limitation on the length of the abstract. However, the suggested length is from 150 to 225 words.

14. **KEY WORDS:** Key words are technically meaningful terms or short phrases that characterize a report and may be used as index entries for cataloging the report. Key words must be selected so that no security classification is required. Identifiers, such as equipment model designation, trade name, military project code name, geographic location, may be used as key words but will be followed by an indication of technical context. The assignment of links, rules, and weights is optional.