

**UNCLASSIFIED**

SECURITY CLASSIFICATION OF THIS PAGE (When Data Entered)

REPORT DOCUMENTATION PAGE		READ INSTRUCTIONS BEFORE COMPLETING FORM
1. REPORT NUMBER AFFDL-TR-78-154	2. GOVT ACCESSION NO.	3. RECIPIENT'S CATALOG NUMBER
4. TITLE (and Subtitle) HANDLING QUALITY REQUIREMENTS FOR ADVANCED AIRCRAFT DESIGN: LONGITUDINAL MODE		5. TYPE OF REPORT & PERIOD COVERED Final Report Feb 1977 Aug 1978
		6. PERFORMING ORG. REPORT NUMBER
7. AUTHOR(s) Ralph H. Smith Norman D. Geddes		8. CONTRACT OR GRANT NUMBER(s) F33615-77-C-3011
9. PERFORMING ORGANIZATION NAME AND ADDRESS Systems Research Laboratories, Inc. 2800 Indian Ripple Road Dayton, Ohio 45440		10. PROGRAM ELEMENT, PROJECT, TASK AREA & WORK UNIT NUMBERS 62201F 20900206
11. CONTROLLING OFFICE NAME AND ADDRESS Air Force Flight Dynamics Laboratory/FGC Wright-Patterson Air Force Base, Ohio 45433		12. REPORT DATE August 1979
		13. NUMBER OF PAGES
14. MONITORING AGENCY NAME & ADDRESS (if different from Controlling Office)		15. SECURITY CLASS. (of this report) Unclassified
		15a. DECLASSIFICATION/DOWNGRADING SCHEDULE
16. DISTRIBUTION STATEMENT (of this Report)  Approved for public release; distribution unlimited		
17. DISTRIBUTION STATEMENT (of the abstract entered in Block 20, if different from Report)		
18. SUPPLEMENTARY NOTES		
19. KEY WORDS (Continue on reverse side if necessary and identify by block number)		
Handling Qualities	Pilot Dynamics	Aircraft Display
Flying Qualities	Human Pilot	Digital Flight Control
Manual Control	Flight Control	
Man-Machine Dynamics		
20. ABSTRACT (Continue on reverse side if necessary and identify by block number)		
<p>This report considers the problem of developing handling qualities specifications for aircraft with nonclassical dynamic response to control. These include closed loop flight control system effects on basic airframe dynamics, direct force control applications, digital flight control, integrated fire-flight control, and integrated display-flight control. Only the longitudinal mode is considered. Elements of classic pilot-vehicle analysis methodology are distilled against a theoretical framework for the prediction of pilot opinion</p>		

DD FORM 1473  
1 JAN 73

EDITION OF 1 NOV 65 IS OBSOLETE

UNCLASSIFIED

SECURITY CLASSIFICATION OF THIS PAGE (When Data Entered)

UNCLASSIFIED

SECURITY CLASSIFICATION OF THIS PAGE(When Data Entered)

rating to develop a simplified and practical approach to handling qualities prediction that is directly applicable to the development of specifications for aircraft flight control system design. The most important effects of motion cues on handling qualities are included within this model. The methods proposed for the prediction and correlation of handling qualities are validated against the largest and most appropriate base of handling qualities data available; the agreement is nearly 100 percent. A set of recommendations are offered for the revision of MIL-F-8785B for longitudinal dynamics and for flight path stability in power approach. These revisions apply to aircraft incorporating direct lift control and digital flight control. Preliminary handling quality specifications for the design of advanced display systems, such as HUD-directed fire control, are also given. A commentary, with supporting analysis and data, is given on inter- and intra-pilot variability, pilot technique, pilot interpretation of control task requirements, and the Cooper-Harper scale. Data and remarks are also provided on the utility of the PIOR scale.

UNCLASSIFIED

SECURITY CLASSIFICATION OF THIS PAGE(When Data Entered)

# *Contrails*

## FOREWORD

This report documents an effort to transfer certain elements of pilot-vehicle system dynamics technology into methods suitable for the development of engineering specifications for handling qualities design of advanced aircraft or flight control mechanizations. The work reported was performed under Contract F33615-77-C-3011, as part of Air Force Project 2090, Task 209002. Mr. Frank L. George and Mr. Brian W. VanVliet, both of AFFDL/FGC, were co-project engineers for the AFFDL. The principal investigator was Ralph H. Smith of Systems Research Laboratories, Inc. (SRL), Dayton, Ohio. Smith authored the final report and performed all analyses except those for flight path stability in power approach; this was done by Norman D. Geddes, also of SRL. This work was performed during the period February 1977 to August 1978. The report was submitted by the authors in September 1978.

The authors gratefully acknowledge the intensive, careful review and technical editing of the final report by Brian W. VanVliet and Robert J. Woodcock. The encouragement given by Mr. Charles B. Westbrook, formerly of SRL, also played an important role in whatever success this work may enjoy. It seems that no matter where one turns in this business, Charlie's influence is felt by those with the wisdom to understand.

# Contrails

## TABLE OF CONTENTS

SECTION		PAGE
I	INTRODUCTION	1
II	EXPERIENCE WITH ADVANCED FCS	3
	A. Background	3
	B. Available Data For Advanced FCS	5
	Handling Quality Requirements	5
	System Integration	6
	Displays and Controls	7
	Six Degree of Freedom FCS	9
	Control Authority	10
	Multimode FCS	10
	Digital FCS	11
	C. The Specification Dilemma	12
	D. An Operational Context	12
III	DIGITAL FLIGHT CONTROL SYSTEMS	15
	A. Background	15
	B. Summary	29
	ADC Resolution	29
	Control Roughness	30
	DFCS Phase Lag	31
	DFCS Architecture	32
	Software-Degraded Handling Qualities	33
	Intelligent Sensors	34
	DFCS Transparency	34
IV	THE ANALYTICAL APPROACH TO HANDLING QUALITIES SPECIFICATION--A CRITIQUE	36
	A. Theory	36
	B. Empirical	37
	C. Specification Development	42

# Contrails

## TABLE OF CONTENTS (continued)

SECTION	PAGE	
D.	The Method of Reference 1	45
	Classic Aircraft-FCS Dynamics	47
	Higher Order System Dynamics	53
	Requirements for Aircraft Class or Flight Phase Category	55
E.	A Role for Pilot-Vehicle Systems Analysis	56
F.	Conclusions	57
V	A UNIFIED, ANALYTICAL APPROACH FOR HANDLING QUALITIES SPECIFICATION DEVELOPMENT	61
A.	Background and Theory	61
B.	The Data and Its Interpretation	61
	Arnold's Data--Average for 5 Pilots	68
	Arnold's Data--Interpilot Variability and Observations on the Cooper-Harper Scale	68
C.	Task Effects on Pilot Opinion Rating and Comments on Rating Variability	83
	Task Effects	83
	Pilot Rating Variability	87
D.	The No-Tracking Hypothesis	88
	Flight Test Implications	88
	Application to Specification Development	89
	An Historical Perspective	89
E.	Lessons From Pilot-Vehicle Systems Analyses	91
	Stereotypes for Aircraft Dynamics	91
	Closed Loop Structural Stability, Mode Switching and Pilot Technique	92
	Effects of Motion Cues	100
F.	Practical Methods for Specification Development	102
	Basic Handling Quality Questions	102
	Handling Qualities Criteria: Preliminary	103

# Contracts

## TABLE OF CONTENTS (continued)

SECTION		PAGE
VI	LONGITUDINAL SHORT-PERIOD HANDLING QUALITY REQUIREMENTS	111
	A. Approach	111
	B. A Proposed Time-To-First-Peak Specifications	111
	C. A Proposed Amplitude Ratio Slope Criterion	116
	D. A Proposed Phase Angle Specification	121
	E. A Proposed Phase Angle Specification for Normal Acceleration Dynamics	121
	Case 1: Conventional FCS or With Maneuver Enhancement	123
	Case 2: Direct Lift Control Modes	127
	F. A Comment on the PIOR Scale	129
	G. A Comment On The Use of Equivalent Systems Time Delay As A Handling Qualities Metric	133
	H. Summary Of Proposed Requirements	135
	I. Handling Quality Requirements For Display Design	136
VII	FLIGHT PATH STABILITY IN POWER APPROACH	138
	A. Necessity for a New Specification	138
	B. Pilot-Centered Flight Path Control Performance	141
	C. A Proposed Specification for Flight Path Stability	149

# Contrails

## TABLE OF CONTENTS (concluded)

SECTION		Page
VIII	HANDLING QUALITY REQUIREMENTS PECULIAR TO DIGITAL FLIGHT CONTROL SYSTEMS	150
	A. General	150
	B. The Transparency Criterion	150
	C. Control Law Implementation and Low Frequency Limits on Allowable Frame Rate	151
	D. High Frequency Limit On Allowable Frame Rate	152
	E. Control Roughness	155
APPENDIX		159
REFERENCES		167

## LIST OF ILLUSTRATIONS

FIGURE		PAGE
1	A Representative Digital Control System	18
2	Pilot-Vehicle System Model for Pitch Tracking in Turbulence	46
3	The Pitch Control Handling Qualities Metric	48
4	Pilot-Vehicle System Dynamics Model for Short Period Pitch Attitude Control: Classic Aircraft-FCS	49
5	Handling Quality Requirements Derived From Pilot-Vehicle Systems Analysis (Schematic Only)	51
6	Variation of $\sigma_q$ With Pilot Rating (Arnold Data)	69
7	Cooper-Harper Rating Error Variation as a Function of Average Pilot Opinion Rating	78
8	The ABC HUD Concept	85
9	Variation of Crossover Frequency With Pitch Attitude Dynamics (From Reference 3)	107
10	Specification of the Criterion Frequency	109
11	Cooper-Harper Rating vs $t_q$ for the Neal-Smith Flight Test Data	117
12	Aircraft-FCS Phase Angle at the Criterion Frequency vs Cooper-Harper Rating	118
13	Design Guide Data for Effect of Phase Angle of Pitch Attitude Dynamics on Handling Qualities	120
14	Acceleration Loop Phase vs PIOR: Conventional FCS or With Maneuver Enhancement	124
15	Acceleration Loop Phase vs PIOR: Direct Lift Control	125
16	The Pilot Induced Oscillation Rating (PIOR) Scale	130
17	The Cooper-Harper Scale	131
18	Engine Thrust Model for Calculation of $\dot{\gamma}(t)$	145
19	Definition of Rate of Sink Parameter, $t_s$	147



# Contrails

## LIST OF TABLES

TABLE		PAGE
1	Pilot Model Parameters for the Arnold Data (Reference 1)	64
2	Pilot Model Parameters for the McDonnell Data (Reference 1)	65
3	Average q-Loop Pilot Gain--Arnold and McDonnell Data	67
4	Pilot Opinion Rating vs $\sigma_q$ ; Subject: Arnold	70
5	Pilot Opinion Rating vs $\sigma_q$ ; Subject: Keiser	72
6	Pilot Opinion Rating vs $\sigma_q$ ; Subject: Silliman	73
7	Pilot Opinion Rating vs $\sigma_q$ ; Subject: Radmacher	74
8	Pilot Opinion Rating vs $\sigma_q$ ; Subject: Bluford	75
9	Summary of Pilot Rating Formula Parameters for Least-Squared Fit to Arnold's Data	76
10	Summary of Handling Quality Parameters (The Neal-Smith Data)	112
11	Summary of Aircraft Aerodynamic Data Required for Estimation of $\dot{\gamma}(t)$ Response to Control	144
12	Summary of Results: Time to Arrest Rate of Sink $t_s$	148

# Contrails

## List of Symbols

<u>Symbol</u>	<u>Description</u>
ADC	Analog-to-digital converter.
a	Amplitude of $\delta_o(t)$ .
a	Magnitude of $q(t)$ threshold; degrees/second.
$a_{z_p}$	Normal acceleration measured at the pilot's location; positive sense is that of the + z-axis (i.e., "down"); g's.
C*	The handling qualities parameter: $\frac{C^*}{F_s} = \frac{-a_{z_p}}{F_s} + \frac{\ell_p}{g} \frac{\ddot{\theta}}{F_s} + \frac{400}{g} \frac{\dot{\theta}}{F_s}$
CAP	The Control Anticipation Parameter, $CAP = \omega_{sp}^2 / n / \alpha$
D	The flight path damping parameter, $D = \frac{ \dot{\gamma}_{max} - \dot{\gamma}_{min} }{ \dot{\gamma}_{max} }$
DAC	Digital-to-analog converter.
DLC	Direct Lift Control.
$F_s$	Pilot applied stick force; pounds.
f	Digital flight control system frame rate or inverse cycle time; Hz.
HUD	Head-up display.
K	A parameter of the pilot rating expression, $R = K\sigma_q^n$ .
$K_c$	Controlled element gain.
$K_{Dq}$	Equivalent display gain in the q-channel of the optimal pilot model.
$K_{Fq}$	Describing function representation for Kalman estimator in optimal pilot model; q-channel.
$\hat{K}_q$	Equivalent pilot gain for control of q in optimal pilot model; $\hat{K}_q = K_{Fq} K_q^*$ .
$K_\theta$	Gain of the equivalent system pitch dynamics model; root locus form.
$K_{\theta 0}$	Value of $K_\theta$ as equivalent systems time delay approaches zero; the classical value.

# Contrails

$\ell_p$	Location of pilot forward of aircraft center of mass; feet.
$m$	Aircraft mass; slugs.
$M_{\delta_e}$	$\rho S U_o^2 c C_{M_{\delta_e}} / 2 I_y$
$n$	A parameter of the pilot rating expression, $R = K \sigma_q^n$ .
$n$	Wordlength in bits of the ADC.
$n/\alpha$	Steady state normal acceleration per steady state change in angle of attack for step input of elevator at constant speed; g's per radian.
PIOR	Pilot induced oscillation rating.
POR	Pilot opinion rating; Cooper-Harper scale.
$q$	$\dot{\theta}$ ; degrees/second.
$q_p$	Pilot perceived $q(t)$ following effects of physiological or display thresholds.
$R$	Pilot opinion rating; generally used to infer a pilot opinion rating as given by various approximating formulae; Cooper-Harper ratings.
$R$	Control rate weighting in the optimal pilot model.
$R$	Range of $x(t)$ used for scaling of the analog-to-digital conversion; $R =  x_{\max} - x_{\min} $ .
$s$	Laplace transform (complex) variable, $s = \sigma + j\omega$ ; radian/second.
$T$	Cycle time of digital flight control system; seconds.
$T_{\theta_2}$	Time constant of the $\theta/\delta_e(s)$ transfer function numerator; short-period approximation; seconds.
$t$	Time; seconds.
$T_E$	Numerator time constant parameter of the equivalent systems model for pitch dynamics; seconds.
TRP	Time Response Parameter from Reference 16.
$t_q$	Time-to-first-peak of $q(t)$ following step input in $F_g$ ; seconds.
$t_m$	Upper limit on $t_q$ for Level 1 handling qualities; seconds.
$t_{\dot{\gamma}}$	Time-to-90 percent $\dot{\gamma}_{\max}$ following step input in throttle, elevon or DLC control; seconds.
$U_o$	Steady-state aircraft speed (x-axis component); Kts or ft/sec.
$V$	Aircraft total airspeed; kts.
$V_{o_{\min}}$	Minimum operational airspeed; kts.
$x$	Any aircraft response variable input to the ADC.

# Contrails

x	Arbitrary vehicle or display response variable used by the pilot for accomplishment of a prescribed task; e.g., vertical separation distance between target and chase aircraft in refueling or formation flight.
$\dot{x}$	$\frac{dx}{dt}$
$X_o$	Average amplitude of $x(t)$ perturbations from the average value of $x(t)$ in a prescribed flight mode and FCS configuration.
$Z_\alpha$	$\rho S U_o^2 (-C_{L\alpha} - C_D) / 2m$

## Greek Symbols

$\beta_q$	Signal from the q-channel of the optimal pilot model to the neuromuscular system.
$\gamma$	Flight path angle; degrees.
$\dot{\gamma}$	$\frac{d\gamma}{dt}$
$\dot{\gamma}_{max}$	First peak value of the $\dot{\gamma}(t)$ response following step input of elevator or throttle; absolute value prescribed; degrees/second.
$\Delta\delta_e$	Maximum value of $ \delta_{e_c}(t) - \delta_o(t) $ ; a measure of the size of the harmonic content of $\delta_{e_c}(t)$ --the DAC output.
$\Delta t$	Change in commanded thrust; pounds.
$\Delta Thrust$	Steady-state change in propulsion system thrust following a step throttle input; pounds.
$\delta_{DLC}$	DLC control, pilot-applied.
$\delta_e$	Elevon (or pitch) control; degrees or radians.
$\delta_{e_c}$	DAC output when the commanded output is a sine wave; a periodic signal.
$\delta_{es}$	Deflection of the pilot's control stick, positive forward; inches, degrees, or radians.
$\dot{\delta}_{es}$	$\frac{d\delta_{es}}{dt}$
$\delta_o$	Fundamental component of $\delta_{e_c}(t)$ ; a sine wave of amplitude a; $\delta_o(t) = a \sin\omega_c t$ .
$\zeta_E$	Short-period damping ratio parameter of the equivalent systems model for pitch dynamics.
$\zeta_{sp}$	Short-period damping ratio; classic aircraft dynamics.
$\theta$	Pitch attitude angle; degrees.

# Contrails

$\dot{\theta}$	$\frac{d\theta}{dt} = q$
$\ddot{\theta}$	$\frac{d^2\theta}{dt^2}$
$\sigma_{q_0}$	Value of $\sigma_q$ for $R = 1$ .
$\sigma_{\dot{x}}$	RMS value of $\dot{x}(t)$ .
$\sigma_{\beta q}$	RMS value of $\beta_q(t)$ .
$\sigma_{\delta_{es}}$	RMS value of $\dot{\delta}_{es}(t)$ .
$\sigma_{\epsilon}$	RMS fit error between average, actual pilot opinion rating and that given by the formula $R = K\sigma_q^n$ ; Cooper-Harper units.
$\sigma_{\theta}$	RMS value of $\theta(t)$ .
$\tau_E$	Time delay parameter in the equivalent systems model for pitch dynamics; seconds.
$\tau_{\text{engine}}$	Engine thrust response time (time to steady state following step change in throttle setting); seconds.
$\phi(j\omega_c)$	Phase parameter for normal acceleration response dynamics; $\phi(j\omega_c) = \angle \frac{a_{zp}}{F_s}(j\omega_c) - 14.3 \omega_c$ ; degrees.
$\omega$	Frequency; imaginary part of $s$ ; radian/seconds.
$\omega_c$	The criterion frequency; approximately equal to the crossover frequency for the pitch control loop; defined by equation 10; radians/second.
$\omega_E$	Short-period natural frequency parameter of the equivalent systems model for pitch dynamics; radians/second.
$\omega_R$	Resonant frequency of any open-loop mode of pitch attitude dynamics; radians/second.
$\omega_{sp}$	Short-period natural frequency of pitch attitude response dynamics; radians/second.

## Miscellaneous Symbols

$\left. \frac{d}{d\omega} \left  \frac{\theta}{F_s}(j\omega_c) \right  \right\}$	The slope parameter for handling qualities; the derivative is the average value on $2 \omega \pm 6$ ; decibels/octave.
$a_{zp} \rightarrow F_s$	The closed loop, piloted control of $a_{zp}$ with $F_s$ considered as the pilot's output.

# *Contrails*

# Contrails

## Section I INTRODUCTION

It is well known that the flying qualities specification, MIL-F-8785B, is deficient for certain of the present generation high performance military aircraft. These deficiencies are compounded where the flight control system (FCS) adds significant dynamic modes or delays to the overall system dynamics. The goal of this report is to assess certain of the deficiencies of MIL-F-8785B and correct these where possible. Only the longitudinal handling qualities problem is considered.

One may approach the task of updating or revising MIL-F-8785B in various ways. The approach adopted in this report is to review the type and nature of advanced flight control systems of current and probable future interest, assess the availability of handling qualities data for such systems, examine the applicability of analytical theories for handling qualities for the development of design specifications, and develop and propose specific revisions to the specification for those combinations of task and FCS that are of most immediate concern to systems development.

The context in which this review will be conducted will encompass considerations of probable operational requirements, anticipated directions that air warfare will take, and expected advances in FCS hardware capabilities.

This report is the third and last of a series. In Reference 1 a review was conducted of the state of the art of pilot-vehicle systems analysis methods, a unified model for pilot dynamics was investigated, and a general, analytical theory for handling qualities prediction was developed. This model provided the theoretical basis for the work of Reference 2. The principal significance of Reference 2 is the manner in which it successfully treats the coupling that can occur between the pilot's visual and kinesthetic senses in precision control tasks; the pilot induced oscillation phenomenon is but a bizarre and limiting case resulting from this coupling. The present report extracts from each of these earlier works those concepts and results

# *Contrails*

that can be most directly applied to the update of MIL-F-8785B. This is accomplished by maintaining close ties with historical work in pilot modeling; the data base of Reference 3, interpreted within the analytical framework provided by Reference 1, was invaluable and remains the only usable source for human dynamic response data applicable to handling qualities research.

A product of the present work is a physical theory for handling qualities that complements and extends the theory of Reference 1. The rather startling concept on which this theory is based will not be a comfortable one with many readers. It may seem to imply that three decades of work on human pilot dynamics has come to a dead end. That is not the case. The theory does indicate that the conventional viewpoint of pilot-vehicle system dynamics vis-a-vis handling qualities misses a fundamental point. Because of this, analytical handling qualities research has usually seemed more abstruse than necessary and not immediately applicable to the problem of airplane and FCS design.



# Contrails

## Section II

### EXPERIENCE WITH ADVANCED FCS

#### A. BACKGROUND

Experience with advanced FCS has been obtained from a potpourri of hardware and simulation exercises--few of which were dedicated to handling quality requirements, per se. Problems explored have included control law development for highly augmented or direct force control systems, multimode control concepts, display system concepts, integrated fire/FCS, etc. These have been mostly ad hoc exercises with specific, limited goals.

In the past, progress in handling qualities technology has primarily come from gathering empirical data, rectifying it against a framework of standards provided mostly by experience, and devising new or modified interpretations of the cause-effect relationship between airframe-FCS dynamic behavior and handling qualities. There has never been sufficient handling qualities data for this purpose. This evolutionary process has been less than satisfactory for the forecasting of handling quality problems, the selection of aerodynamic configurations, or the design of automatic flight controls. It has worked only for those aircraft/FCS that have exhibited relatively little dynamic coupling between classic airframe modes and FCS modes.

Handling quality specifications based on experience are proving to be inapplicable for some aspects of the design of advanced FCS of current interest. For such systems the handling qualities data base is sketchy, piecemeal, and too weak to support an entirely empirical approach to updating MIL-F-8785B. In short, there is no obvious way to parameterize the handling qualities problem in view of the almost unlimited variety of airframe-FCS combinations and changes in operational usage that current and near-future hardware capabilities can permit.

Underlying the present MIL-F-8785B and the whole of handling qualities technology is an implicit concept of piloting task requirements. With the integrated flight, fire, propulsion, and display systems of the sort now

# Contrails

being considered, and in some cases developed, it is no longer clear what the effects of changing piloting tasks will be on handling quality requirements. A major part of this problem is that it isn't clear what the specific task definitions will be for advanced systems concepts. New concepts for control of aircraft path, new sensor capabilities, new weapons, and new threats, may mean that the critical conditions for advanced FCS design may occur for tasks that haven't yet been identified.

Or will they? The one fact that seems completely clear as a result of the current handling qualities specification dilemma is that we have no clear picture of what specific vehicle-environmental factors cause good or poor handling qualities. As a result, we are unable to make a priori assessments of task influences on aircraft-FCS design requirements for satisfactory handling qualities. The problem does not easily lend itself to empirical study.

Consider the classic problem of air-to-air combat with guns. Methods exist (Reference 4) for handling qualities assessment and quantification for fixed reticle target tracking once the difficult problem of target acquisition has been solved. We have no useful, practical method for analysis of the latter problem; it isn't clear what could be done with it if we had it. Efforts were taken in Reference 1 to establish and defend the hypothesis that those features of small amplitude tracking which promote good or poor handling are inseparable from those of importance to the more general large amplitude motions of air combat tasks. Therefore, it was argued, good handling qualities in tracking seem to be a prerequisite to good handling qualities in general. Though this may be good logic, it isn't of much help for understanding FCS design requirements for the effective use of guns in nontracking tasks (e.g., snap-shooting).

In Section V of this report the argument above, from Reference 1, will be inverted. The resulting handling qualities theorem will enable a unified treatment to be made of virtually any FCS-task combination for which handling qualities are a legitimate consideration. In the remainder of this section, a brief examination will be made of data available about the character of advanced FCS and the operational theatre in which they may be required to

# Contrails

perform. These data will then be used where possible to provide general support for the handling quality requirements derived from the theory of Section V.

## B. AVAILABLE DATA FOR ADVANCED FCS

There have been very few recent simulations or flight tests conducted for the purpose of collecting handling qualities data. It is not our intent to chronicle the history of specific work done in this subject area. Only an overview with comments on the utility of past work to the task of revising MIL-F-8785B will be provided. The principal advanced systems studied include:

- B-52 CCV
- Survivable FCS/PACT
- F-5E Austere HUD/Gunsight
- AFTI
- TWEAD I/II
- F-8 Digital FCS
- DIGITAC (A-7) I/II
- CCV-YF-16
- Firefly (F-106 Integrated Fire/FCS)

Little or no reference material was available for the YF-17, F-14, F-18, YC-14, YC-15, or space shuttle.

### Handling Quality Requirements

The pervasive belief in all this literature is that MIL-F-8785B does not satisfactorily address the problems of designing state-of-the-art advanced FCS. There is a strong undercurrent of opinion that the dynamic requirements of MIL-F-8785B can be supplanted with time-response measures. It isn't difficult to appreciate the appeal of time response methods for handling qualities prediction. Methods such as C\* and TRP--both of which will be discussed later in this report--have an intuitive motivation, are easily applied, and correctly predict handling qualities for at least some configurations of airframe and FCS dynamics. However, frequency domain models for handling

# Contrails

qualities also continue to have an enthusiastic following. The experimental results of References 5 and 6 were assayed in Reference 6 where it was concluded that C\* was not an adequate handling qualities model. A new criterion, based upon frequency domain measures of pitch attitude dynamics was proposed and is now used as a research tool by several organizations.

References 5, 6, and 7 comprise the fundamental data base for studies of advanced FCS. Arnold's experiments were the fixed-base equivalents of the Neal-Smith configurations for those cases where higher order FCS dynamics were negligible. Arnold's data, when compared with that of Neal and Smith, enable a quantitative assessment of motion cue effects on longitudinal handling qualities. This is a vital link in the development of design specifications for direct force control systems.

## Systems Integration

The greatest single deficiency in many test programs conducted for the study of advanced FCS concepts is the total lack of consideration given to overall systems integration considerations in evaluation of specific hardware approaches to FCS design solutions. The problems of hardware prototype design and man-rating, and the difficulties and expense of flight test, appear to have almost completely overridden any considerations of experimental design and test for the collection of handling qualities data. In part, this has resulted from the lack of any unifying plan for the organization of such research for this purpose. It is comparatively easy to build and test equipment; handling qualities problems, in contrast, are depressingly elusive to classify or quantify and expensive to evaluate. No one has ever successfully quantified the benefits to weapons systems effectiveness or flight safety of good handling qualities. The quarrelsome handling qualities "community" can --except for extreme cases--never agree about what constitutes good or poor handling qualities. Since major R&D test programs, whatever their original objectives, inevitably become cost and schedule driven, it isn't difficult to understand why so much testing is done with so little impact on the handling qualities state of the art.

# Contrails

However, it is difficult to understand how, in those occasional instances where reasonable and timely input is made about handling quality test requirements, such advice can be ignored. This has happened in past work to the detriment of present hardware design, test capabilities, and weapons system effectiveness.

## Displays and Controls

There appears to be a general concern in the flight control area about the problems of integrated control and display design. Display and cockpit architectural requirements for the implementation of advanced FCS concepts involves at least three mutual considerations; viz. the usual human factors considerations of display size, position and symbology, tolerable or desirable display dynamics (including display gain or nonlinearities), and the effects of weapon or piloting task on display requirements. It is within the state of the art to implement a display system that is entirely computer generated with features that vary according to flight condition or task (the multimode concept).

Many specific considerations of advanced FCS display requirements are found mostly in the literature of gunsight design, test, and evaluation. Interesting work has also been conducted for the approach and landing task on the question of what cues are most beneficial to task performance. Such work has been of the ad hoc variety. The unifying concept required to rationalize display design is lacking.

It does appear that the potential for interaction among weapons employed, display, and flight control is now widely recognized. The notion that clever display design can account for deficiencies in airframe-FCS dynamics is no longer so radical as it once seemed. More important, it now seems to be fashionable to consider that handling qualities can be affected as much by display design as by the airframe or the FCS.

Little attention has been given to the design requirements for control manipulators. With few exceptions, our data base for feel system requirements

# *Contrails*

predates the widespread use of stability augmentation systems. It appears that a new generation of handling quality specifications will be required for manipulator design and feel characteristics for highly augmented or multimode FCS. It is likely that the test and evaluation of radical concepts for FCS will require that careful attention be given to manipulator design if the results are to be credible. Evaluations of direct force control systems, in particular, seem to be sensitive to manipulator design. Evaluations of such concepts should also consider their probable operational usage. It seems naive to imagine that direct side force control will, in the near future, be used to evade a missile attack; it may, however, be an effective control for approach and landing, aerial refueling, and ground attack. In general, it appears that the independent control of lift or side forces by the pilot is not a satisfactory control technique.

Control or mode select switching is accomplished in even the latest fighter cockpits by using forty year old technology. For piloting tasks so complex and demanding as single seat, night, ground attack or Wild Weasel missions, the demands being placed on the pilot by utility requirements threaten mission effectiveness and combat survivability. Voice actuated control technology is now being examined as one approach to simplifying the switching required by modern attack concepts. Other approaches entailing more automation of specific tasks are feasible.

Gunsights (fixed reticle, lead computing, etc.) have received considerable attention. The viewpoint here is that gunsights or computer aided tracking devices, in general, are specialized displays and should be treated as such. The concepts of fuselage pointing (via the use of direct lift and side force control) and independently aimable guns have an impact on the display required. The so-called Big Pipper concept for HUD design for air-to-air combat is a natural marriage of the concept of integrated fire control and display. The hardware capability now exists to develop fire control systems based on concepts of this sort. Their systems effectiveness has yet to be completely demonstrated.

# Contrails

The TWEAD program provides an interesting case history of the influence of display dynamics (in this case, gunsights) on handling qualities task evaluations. The case is well known and needn't be discussed in detail. It can be concluded from the TWEAD experience, and others, that:

- Lead computing gunsights may be good in theory but when reduced to practice they can be severely degraded by inappropriate display design.
- Display dynamics can have an overwhelming effect on handling qualities (Cooper-Harper ratings) almost without regard for airframe or FCS dynamics.
- In air-to-air tracking with guns the pilot's handling qualities evaluation is based upon task performance--not aircraft response to control, per se. The display is very much a part of this loop.

When the TWEAD experiences are compared against the Neal-Smith<sup>6</sup> and Arnold<sup>7</sup> data bases (as interpreted by Smith<sup>1</sup>) it is possible to establish a corollary of importance to display design: proper display design can, for a particular task, improve handling qualities resulting from less than ideal airframe-FCS dynamics.

## Six-Degree-of-Freedom FCS

Six-degree-of-freedom FCS appear to be much discussed but little analyzed. In the AFTI program the selection of control laws for mode blending has been a major concern. However, it is difficult to see how these experiences can be salvaged and consolidated to the benefit of future systems developments, in general. One is left with the impression that, without flight simulation as back-up (in some cases, primary), no viable basis for control law development would exist. The problem has been treated in ad hoc, seat-of-the-pants fashion. However, it may be a serious error for handling quality research to get drawn too deeply into this problem. Control law development will be driven by factors outside the handling qualities domain. The handling qualities contribution should be to:

# Contrails

- Quantify the required aircraft responses to control in state regulation (tracking) or in the initiation or termination of state changes.
- Define acceptable solutions to the trim control problem for tasks where steady state solutions are practically nonexistent (as in phases of air-to-air combat, for example).

This is far simpler than the general problem of control law definition. However, the results of such specifications will have a clear impact on the choice of allowable control laws.

One finds, in the flight control literature, a general concern for the effects on handling qualities and flight safety of unusual motion cues due to control blending and direct force control. Considering the difficulties experienced with so many new (conventional) aircraft due to the pilot induced oscillation phenomenon, these concerns may be well founded. A physical basis for understanding and eliminating such problems is now available.<sup>2</sup> However, there has been no satisfactory method for a priori assessment of the effects on handling qualities (as reflected by Cooper-Harper ratings) of motion cues, per se. This matter is considered in Section VI.

## Control Authority

Another aspect of fly-by-wire or high authority FCS that has scarcely been considered is the effect of control system saturation on handling qualities, flight safety, or any restrictions to the flight envelope. Control saturation, particularly with an aerodynamically unstable airframe, could easily lead to loss of control or PIO. It appears that the requirement exists to develop design specifications to avoid control saturation or loss of control if it occurs.

## Multimode FCS

The multimode FCS concept seems to be gaining currency. With a digital FCS and integrated control-display system, multimode operation appears to be



# Contrails

practical. There is, however, little factual basis for the assessment of handling quality problems associated with the concept. One obvious problem area that does not appear to have been systematically addressed in recent work with advanced FCS is that of suppression of FCS transients induced by mode switching.

## Digital FCS

A significant amount of research, hardware development, and flight test has been conducted in the area of digital flight control systems (DFCS). The first operational, all-digital United States warplane, the F-18, is nearing first flight status. A primary benefit of DFCS lies in the flexibility afforded by the system for making FCS modifications and for integration of the FCS with propulsion, display, fire control, or avionics systems. This can be done with software changes only--at least in principle. However, penalties must be extracted to obtain this flexibility. Among these, the software-associated problems loom ominously: how does one verify DFCS software? The hardware required for analog-to-digital conversion (ADC) or digital-to-analog conversion (DAC) may very well prove to be inseparable from the FCS architecture selected. The concept of a bus-oriented DFCS, including remote sensor elements, actuators, display, and central processor is being considered and seems like a natural evolution of the DFCS concept. Curiously, however, there appears to have been no attention given thus far to the development of "smart" peripherals. These might include inertial reference systems, accelerometers, gyros, angle-of-attack sensors, etc. which consist not only of transducer elements, but also contain microcomputers with enough power to perform substantial data preprocessing. The results, rather than the transducer signals, could then be transmitted to the central processor when requested. From the limited flight testing conducted to date, it appears that the hardware problems associated with building and flying a DFCS, and the flight safety aspects of fly-by-wire systems have overridden considerations of handling qualities requirements; opportunities for the collection of handling qualities data have been lost.

# Contrails

Despite the experience accumulated with advanced FCS, our knowledge of the handling quality requirements for such systems is sketchy. The principal data base for MIL-F-8785B does not include usable, quantitative data for high technology FCS concepts that greatly depart from classical designs.

## C. THE SPECIFICATION DILEMMA

In a period of rapid technological change, such as we are now seeing, it is impossible for MIL-F-8785B to anticipate the future handling quality requirements so long as either MIL-F-8785B remains rooted in the empirical practices of the past, or a physically realistic theory for handling qualities is lacking.

The task-related nature of handling qualities is now popularly recognized. However, for the FCS concepts addressed by this report, it isn't clear what the critical pilot tasks will be; therefore, how does one collect data sufficient to develop design criteria for such systems? The complicating factor in this scenario is really the changing nature (or the possible change) of air warfare tactics as a result of the changing threat, enhanced avionics capabilities, and the hardware and functional integration of aircraft subsystems.

The need for an alternative approach to the specification of aircraft handling qualities has been recognized for some time. The difficulty is in developing an approach that is acceptable to the services and to those who must implement the design requirements, yet is physically sound.

## D. AN OPERATIONAL CONTEXT

The design and procurement of a new weapons system occurs in response to an operational requirement. The intended use of a weapons system will determine the technology mix employed in the design of the system. How these technologies will be integrated and what demands they will impose on handling qualities design will depend on many factors. It is important that a general appreciation for the tactical requirements of advanced warplane systems be

# Contrails

acquired if we are to successfully transition from the handling quality design requirements for classic aircraft and tactics to those for tomorrow's systems.

The recently completed AIMVAL/ACEVAL program was designed to improve our understanding of the weapons and tactics best suited for a one-to-two disadvantage. A major finding of ACEVAL was that superior numbers generally are an advantage in combat--although why this should be a surprise is a question worth pondering. Once an aerial engagement begins, pilots are unable to concentrate on multiple targets and must rely on a wingman to clear their rear quarter to prevent the development of a tracking situation.

In developing its air combat adversary program, the U. S. Navy has made use of one-versus-many tactics in deploying its adversary aircraft. The primary mission of the adversary program at VA-127, a Navy attack squadron based at NAS Lemoore, is to teach defensive tactics to fleet A-7 squadrons. The unit is also tasked with fleet instrument flight training and foreign student training in the A-4F. Because of its multi-role function, the squadron usually deploys its aggressor A-4 aircraft singly against from two to twelve A-7E aircraft. Aggressor pilots attempt to disrupt the defensive formation of the A-7s. A characteristic attack is made at very high energy. No attempt at tracking is made. The loss of energy and the predictability of flight path associated with tracking increases the aggressor's vulnerability almost to the suicide level in the one-on-many engagement.

The impact of aircraft physical size has been recognized in air combat; size is increasingly important in one-on-many engagements. This may seem surprising in an era of sophisticated avionics; however, the state of the art of air warfare is still such that no pilot will keep his head buried in his instruments. Head-up, helmet mounted, audio, or other display technology isn't yet operational for this complex situation. A prime rule of air combat remains that "eighty percent of the fight is keeping the enemy in sight." Aircraft with low visual detection profiles will have the advantage in disrupting enemy tracking opportunities and maneuvering. Aircraft with large planforms are easily seen in turning flight.

# *Contrails*

The correct interpretation of AIMVAL/ACEVAL results will be disputed for some time. We do not intend to address that matter here. It does seem plausible, however, that United States aircraft, fighting numerically superior forces, will be relying heavily either on air-to-air missiles or on guns--but not in the classic dog-fight manner. It is possible that tracking, per se, is dead as a viable strategy for our aircraft in future combat operations. The implications of this possibility to MIL-F-8785B are important to consider.

The impact of the deployment of sophisticated, effective surface-to-air missiles could also affect the nature of the handling qualities problem. It is anticipated that no combatant could survive in the airspace from 1000 to 20,000 feet altitude within a battle zone with present defensive missile technology. For the close air support role, particularly, the piloting tasks will qualitatively change. High speed, terrain avoidance, guidance and navigation systems with supporting display and FCS will be likely complements to all our future fighter/attack aircraft. A goal for handling qualities research should be to ensure that the requirements for such systems are forecast and satisfied long before hardware or FCS/display architecture becomes immutably frozen.

## DIGITAL FLIGHT CONTROL SYSTEMS

## A. BACKGROUND

Despite enormous progress digital control technology is still in its infancy. It is rapidly emerging, however, and offers great potential for increasing system flexibility and enabling true integration of a variety of subsystems. The motivation for digital control is simply stated: expensive hardware-intensive control logic and devices can be replaced with a digital computer and appropriate computer programs; the functional performance of a digital system can be changed by modifying the controlling program (the "software"). For flight control tasks that involve considerable cross-coupling of controls or nonlinear responses with change of operating state, the DFCS appears to offer substantial simplification. A DFCS can have many modes of operation, limited only by memory size and required speed of operation; the mode can be selected manually or under program control. The organization of a digital system is well-suited to the integration of subsystems such as flight control, fire control, navigation, avionics, propulsion, and display.

The purpose of this section is to present an overview of digital control technology and its general areas of impact on aircraft handling qualities. A portion of this material is tutorial and intended only as a discussion of the basics. In the interests of clarity no attempt will be made to address the subtleties of digital control. The discussions of system "architecture" (bus structure, single vs multiple central processing units (CPUs), input/output design, etc.) are generic, only. No discussion is offered of internal architecture of the CPU, per se, or of the connection between it, the CPU instruction set, and its impact on software design and the limits this may impose on the speed of program execution. The reader who is knowledgeable about these points doesn't need much of the material in this section; we hope he will not be offended by the superficial discussion of matters that are critical to the design of a successful DFCS. However, there are subtle but definite connections between the hardware and software choices in DFCS design and the resulting aircraft handling qualities. It is our opinion that these are not

# Contrails

being adequately considered in state-of-the-art DFCS design. In this section some of these subtle and not-so-subtle points will be addressed in order to establish a foundation for the recommended revisions to MIL-F-8785B in those areas where digital control, per se, can have unfavorable effects on handling qualities.

It is worth repeating here that airframe-FCS dynamics that look good with respect to the classic servo measures of system response are useless in flight if the pilot can't accomplish intended tasks with acceptable dynamic performance, or if flight safety is compromised by pilot-vehicle dynamic mismatches. This seems to be happening with increasing frequency as flight systems become more complex. Design mistakes happen too often with reasonably conventional control systems; however, the opportunity for errors in both concept and execution is vastly increased with DFCS.

The functional capabilities of a DFCS are limited only by

- Sensor or transducer capabilities
  - Control actuator performance
  - The speed, relative to real-time, with which the FCS computer can execute the required control program
    - . . . computer hardware limitations
    - . . . computer software limitations
  - The pilot
- }      Analog domain
- }      Digital domain

In the remainder of this section the coupling that exists between these areas will be discussed with respect to the handling qualities problem. It may help to observe, at the outset, that the digital computer does not run in "real-time" (i.e., the time of the analog process that it is used to control). Its time base is that of a "clock" that is a central part of the computer system. The clock speed (relative to real-time) is controllable over a broad range; this is done by the system hardware designer through the choice of crystal-controlled oscillator components, etc., which are used to generate the clock time-base. A large part of the difficulty in digital control system design is to make digital commands to the control actuators appear, for

# Contrails

practical purposes, to occur in real-time. With conventional DFCS designs this requires a trade-off. The essential difficulty is that a trade-off must be made between the quality and the frequency of control command. This trade-off is really the only point this section addresses. We point out that the usual problem is to make the digital system "fast enough" to be compatible with the analog world; in a practical system, with today's computer hardware, the problem of "slowing down" the digital system never arises.

To one weaned on analog control systems, digital systems can seem very confusing. The jargon, particularly, is strange and its practitioners seem to delight in keeping it that way. Words like bits, bytes, words, word length, bus (or buss, in some publications), central processor, peripheral processor, memory, arithmetic logic unit, clock, machine cycle, accumulator, RAM, ROM, PROM, EPROM, TTL, ASCII, etc. comprise the language of digital systems. A further complication is that digital technologists generally belong to one of two clubs: the software club or the hardware club. Stories are legion about the problems of system design and operation due to poor or nonexistent communications between these two groups and the design interface problems that can result from one group's failure to adequately address the needs of the other. In this respect, we note that there is probably more experience with digital-based industrial process control systems than with flight control systems, per se.

A particular digital control system is schematically illustrated in Figure 1. There are four parts to this system: the analog system consisting of the plant to be controlled, the control actuators, and the response transducers; the digital computer, consisting of central processor (the "brain"), a clock and a memory; interface hardware for accomplishing analog-to-digital conversion (ADC) or digital-to-analog conversion (DAC); an input/output (I/O) section consisting of mass storage devices, command and control devices, and display devices for communication to a human operator. Although multiplexing is shown, some signal paths may be hard-wired.

The system of Figure 1 is merely one of an infinity of possibilities--although it is reasonably representative of current design practice. The

# Contrails

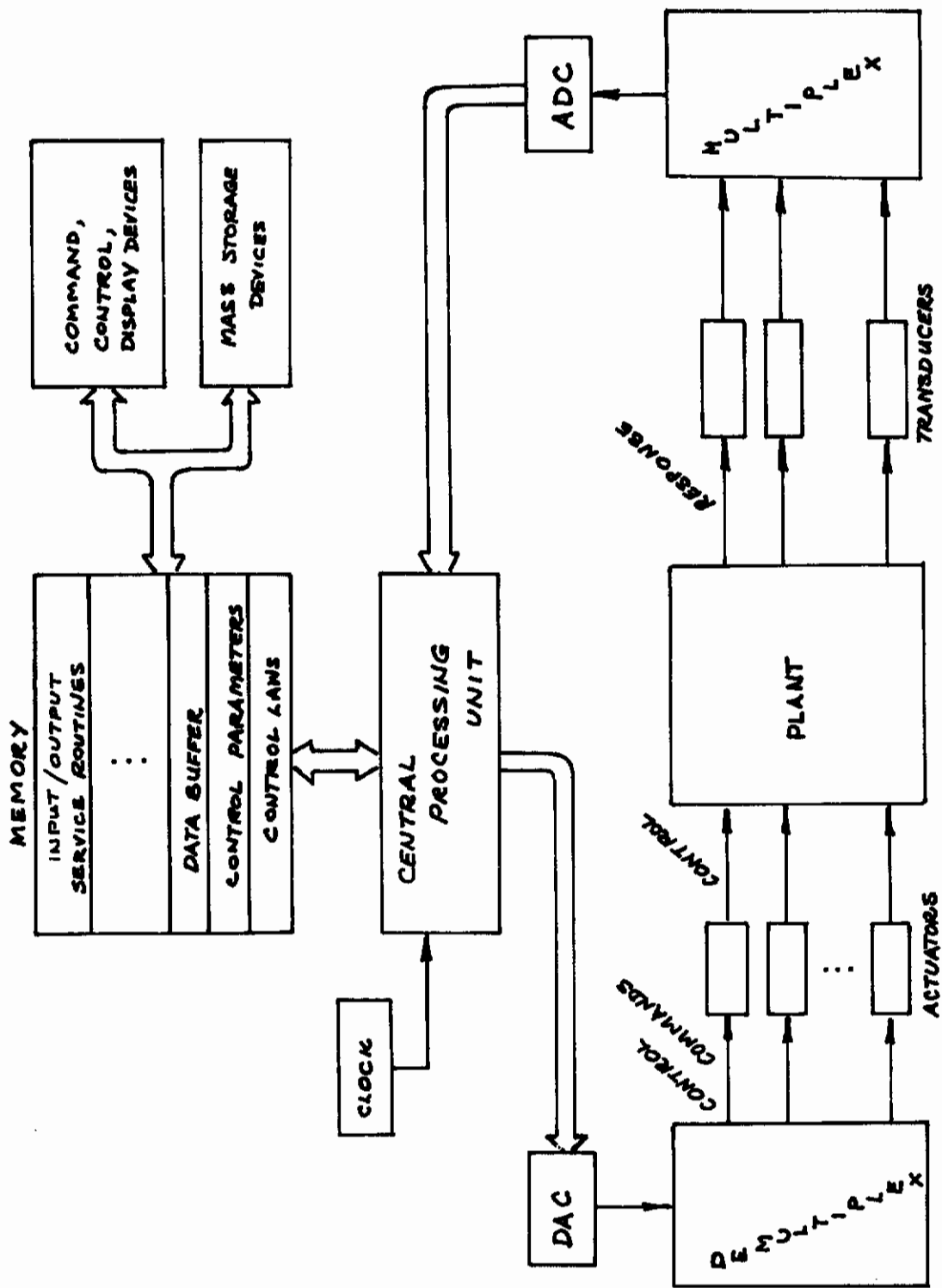

Figure 1. A Representative Digital Control System



# Contrails

systems organization for multiplexing and demultiplexing is arbitrary and depends largely upon the requirements for system performance (speed of operation and accuracy) and cost constraints. Buffering and sample-and-hold functions are implied but not shown on Figure 1.

Within the digital portions of a system, communications take place over "buses"; these are shown in Figure 1 as the broad signal paths to distinguish them from analog signal paths. Three distinct signal buses are shown corresponding to whether the information to be transferred is a digital control signal, data to be transferred to or from memory or mass storage, or a location "address" in memory. Each bus is physically constructed of a number of individual signal conductors (e.g., traces on a printed circuit board); each element of a bus only transmits a "high" or a "low" voltage. Roughly a high voltage will be from 2.0-5.0 volts and will represent a logic true or 1. A low voltage will be 0.0-0.8. volts and will represent a logic false or 0. Other conventions exist. A typical micro or minicomputer bus will consist of 8, 12, or 16 such elements. The information carried by each element is called a "bit," which is a contraction of binary digit. Eight bits make one "byte." One or more bytes make a "word" (the number depends upon the design of the CPU; this will largely determine the way the "memory" is organized). A microprocessor typically has one word equal to one byte (eight bits); for a minicomputer it may be 12, 16, or 32 bits; for a CDC6600 one word equals 60 bits.

To illustrate the transfer of information between the analog and digital portions of Figure 1, consider that a transducer signal equal to 12 volts is to be converted to a digital signal and passed to the central processor unit. The ADC requires that the analog signal be scaled. This is generally done much as one would scale an analog computer simulation. For simplicity assume that the maximum transducer output is 255 volts and the minimum output is 0 volts. Further, assume that the digital signal is to be transmitted over an 8 bit data bus. Then we can (arbitrarily) decree that

# Contrails

0 volts, analog =  $\underbrace{0000\ 0000}_{8\ \text{bits}}$ , digital

most significant bit  
least significant bit

255 volts, analog = 1111 1111 , digital

where the digital signals are expressed in binary (base 2) format; that is  $01_2 = 1_{10}$ ,  $10_2 = 2_{10}$ ,  $11_2 = 3_{10}$ ,  $100_2 = 4_{10}$ , etc. Then 12 volts, analog = 0000 1100, digital.

The ADC, in accomplishing this process, introduces error. The most obvious error is due to quantization; a finite number of bits are available to represent an infinity of analog values. In the present example the maximum quantization error would be  $\pm 1/2$  volt since 1 bit equals 1 volt. Another error is the delay time introduced by the ADC, including multiplexing operations. The principal hardware elements of modern multiplexers and ADCs are transistors used as switches, tracking amplifiers, or comparators. Let us make a brief aside to consider the physical nature of digital systems hardware, after which we shall return to the question of time delays in ADC.

It is important to realize that there is no such thing as true digital hardware; it's all analog. What we identify as the digital component response (i.e., the high or low voltage output) is merely the steady state part of the analog response. The digital device--typically constructed with a transistor network--has the distinguishing property of having only two possible steady states; i.e., it is bistable. The transient responses of digital devices look not unlike those of a linear filter when examined with an oscilloscope. The normal modes, however, are in the megahertz range; the settling time is typically a few nanoseconds. The operation of the ADC and, in fact, all the digital process mechanics require the sequential operations of many devices, all of which behave this way. The elimination of errors due to device transients (which could cause a high to be interpreted as a low, or vice versa)

# Contrails

requires that the next switching period not be initiated until all previous transients have dissipated.

The switching intervals for all the digital hardware are determined by the central processor's "clock," shown in Figure 1. This clock, coupled with the bistable device response, is a principal feature which distinguishes digital from analog systems. The clock has been likened to the crank on an organ grinder; the faster it is turned, the faster the music comes out. For the digital system, however, the crank can't be turned so fast that the analog portions of the digital device responses are not allowed to settle. The clock signal can be any square-wave-like signal; it is usually a crystal controlled oscillator with leading and trailing edges squared up to yield precise timing signals for the entire system. The clock frequency fixes the operating speed of the digital system. Note, however, that the analog portion of the system (i.e., the plant and its actuators) continues to respond to the current control state regardless of how fast the digital system works. Thus, it is plausible that control inputs due to digital output "updates" could be applied at just the wrong time so that plant responses are amplified rather than suppressed. This would be analogous to the case of sizable lag in an analog control system. It is therefore intuitively plausible that, for given plant dynamics, a minimum clock frequency is required for stable system operation. This intuitive notion can be made "rigorous" via z-transform or similar techniques. One wonders, however, how much rigor remains following implementation of the necessary physical and mathematical assumptions required to treat problems of any complexity with available analysis tools.

The clock frequency is one of the single most important parameters of a digital control system. It directly limits the bandwidth of system dynamics and system accuracy and stability. The clock speed is limited by the CPU design and the settling time of the computer memory--both state-of-the-art limitations.

In order to perform an analog-to-digital conversion it is necessary that several clock cycles occur. The exact number required depends upon the hardware approach used in the ADC design, upon the number of data bits used and,

# Contrails

in some designs, upon the properties of the signal being converted. Since a typical digital system clock frequency might be about 2-5 MHz (i.e., clock period,  $T = 200\text{-}500\text{ns}$ ), then the conversion time for a single channel of Figure 1 would typically be  $8T \times (\text{number of channels}) = 20\text{-}40 \mu\text{s}$  for an 8 bit converter with 10 multiplexed channels. This doesn't seem like a significant effect (at 10 radians/second the corresponding phase lag would be only about  $.01^\circ$ ); in fact, it isn't significant in this example. However, the analog-to-digital conversion time does put an upper limit on the theoretical speed at which the digital system can operate. Other, more serious, bottlenecks exist to restrict the allowable speed of the digital controller. Among these, "slow memory" is an important restriction on the system cycle time. In order to execute a computer program stored in memory, it is necessary to move the program stored in memory into the CPU; the program instructs the CPU how to perform the intended control function. However, the CPU may be visualized as a vast network of on/off switches (they have been built with relays, for example). In order for the CPU to "read" and interpret the instruction stored at a particular memory address, as many as 20 CPU clock cycles may be required. If the clock cycle time is 250-500 ns, then the corresponding delay due to a memory read operation is 5-10  $\mu\text{s}$ . Again, this doesn't seem like a lot; the difficulty, however, is that many such operations are required to perform a control function of any complexity.

These hardware delays coupled with the "software bottleneck" constitute the basic restriction to the speed at which a control law (or the equivalent) can be implemented. To this point we've really been talking only about time delays in a digital system due to hardware elements. Once an analog signal has been digitized, it must generally be processed according to predetermined rules. These rules constitute the "software"; they are called the "program" and are stored in memory. Even the simplest of digital control systems will require that quite a number of memory read/write operations be performed in order to process the input, as data, into a control command.

Consider a very simple digital control system. Assume that the processing required of the input data (the transducer output) is no more complex than multiplication by a constant. This would occur, for example, if one

# Contrails

wished to mechanize a pitch damper. How does one multiply two numbers? There are two approaches. The first is to output the two numbers to a special hardware device which will perform the multiplication and return the result. It isn't as easy as that, of course, but that's the basic procedure. The second approach is to perform a software multiplication. This could be done--but usually isn't--as a sequence of additions, for example. These are easy to do; all central processing units are capable of adding two binary numbers. The difficulty is that a great many manipulations may be required to do this. A computer program for dividing two binary numbers is considerably more complicated yet. Typical times required for utility mathematics are given in the following table for two extreme examples of computer performance.

Operation	Time Required Microseconds		
	Microcomputer <sup>1</sup>		CDC6600 SYSTEM <sup>2</sup>
	Software Floating Point	Hardware Floating Point	
Add	400	10	0.4
Subtract	400	10	0.4
Multiply	3,000	50	1.0
Divide	5,000	100	2.9

<sup>1</sup>Based on Intel 8080, 7 digit precision (typical)

<sup>2</sup>14 digits precision (typical)

A complete software package for performing the arithmetic required for implementation of advanced FCS laws might require several thousand computer words (the "program"). Two or three thousand would be required just for the elementary functions tabulated above and for the computation of basic trigonometric and logarithmic functions. Many more would be required for matrix operations typically used in guidance functions.

# Contrails

So far, we've ignored the question of how to code a number in binary format so that it can be conveniently used for mathematical applications. The result of the ADC, for example, must be properly coded in a manner consistent with the overall functional requirements of the system. Speed vs accuracy trade-offs are inevitable at this point and their optimization is an important part of practical system design. This is not a problem that can be left entirely to the programming team. The systems-related cost and hardware aspects must be considered. Usually, a floating-point number representation is used; one of many possible number representations is illustrated below:

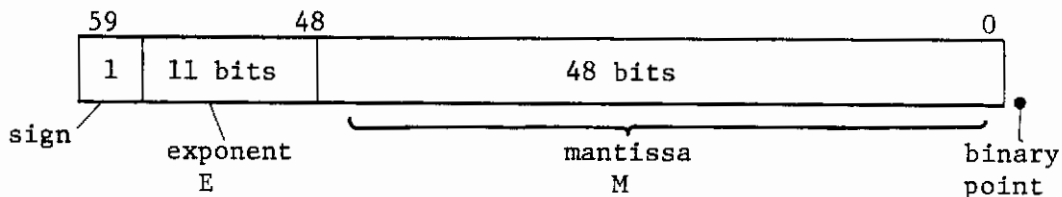

$$N_B = (\text{sign}) M \cdot \times B^{\pm E} = \text{floating point number expressed in base B}$$

B = base of exponent (typically 2 or 16)

M = mantissa expressed in base B

The floating point number representation in the language of the CPU (i.e., in binary) requires a conversion from (usually) decimal input to the number representation in the base B. This establishes the values M and E. Finally, M and E are converted to binary and stored according to the illustrated format. The sign of the mantissa is explicitly indicated (sign bit = 1 indicates a negative number; sign bit = 0 indicates that M is positive). The sign of the exponent E can be handled with an additional sign bit or by other software coding techniques. The number representation shown is that used for single precision on the CDC 6000 series computers. When the computer word length is less than that of the software floating point number representation--and this is the usual case for FCS computers--then more than one word must be linked form a floating point number. The militarized version of the DEC PDP 11/70, for example, is a 16 bit word length machine. The number representation shown would not be ideal for it. It is apparent that the more total bits used to represent a number in floating point format, the more complex the software,

the more memory required, and the slower the operating speed of the controller.

When a transducer signal is converted to a digital format by an ADC, a software penalty is incurred which, in the flight control context, can have significant effect on the overall system dynamics. The digital output of the ADC must be placed in the prescribed floating point format. This conversion must account for the various scale factors involved in the ADC and other physical units. For example, pitching velocity  $\dot{\theta}$  may be measured by a rate gyro and the resulting signal (voltage output proportional to  $\dot{\theta}$ ) supplied to an ADC. Assume the ADC has a 12 bit word length, that the range of  $\dot{\theta}$  is from  $-90^\circ/\text{s}$  to  $+90^\circ/\text{s}$ , and that the corresponding range of the rate gyro output is  $-5$  volts to  $+5$  volts. The ADC resolution is

$$\frac{+5 - (-5)}{2^{12}} = .00244 \text{ volts}$$

That is, each binary digit produced by the ADC is equal to .00244 volts of transducer response referenced to  $-5$  volts. The transducer scaling is  $\frac{10}{180}$  volts/degree/second. If, at the end of a conversion cycle, the ADC places on the data bus (Figure 1), the following binary number

$$1010 \ 1000 \ 1001 = 2697_{10}$$

then the transducer response is

$$-5 + 2697 \times \frac{10}{2^{12}} = 1.58447 \text{ volts}$$

and the pitching velocity is

$$1.58447 \div \frac{10}{180} = 28.52 \text{ }^\circ/\text{s}$$

If the accelerometer response is a nonlinear function of  $\dot{\theta}$ , then the calibrated response must be stored in the computer (as a table, an equation, etc.) and the conversion of the ADC output is complicated by the requirement for table look-ups, equation solutions, etc.

# Contrails

In general, the control laws to be implemented are complex functions of the rigid body Euler angles and their rates, the acceleration components, angles of attack and sideslip, performance restrictions (e.g., g-limiter), control authority restrictions, etc. All these physical quantities must be measured, digitized, scaled, and operated upon in some manner by the digital computer. The software which implements the control laws may require the generation of trigonometric functions, coordinate transformations, matrix inversions, the numerical integration of differential equations, digital filtering, etc. These processes are all software-intensive. They can require considerable memory size. They require execution times that are invariably significant with respect to the system dynamics that they are intended to control.

Figure 1 shows only one central processor unit (CPU). Another hardware bottleneck of significance to DFCS is that the CPU can only perform one function at a time. When more than one action is required (e.g., pitch augmentation plus display update) the CPU must be time-shared between these functions. This is accomplished with a software "executive"; this is the main computer program that, in effect, directs the use of the CPU, establishes the priority of functions to be performed, and controls the timing of these functions.

By now, it should be evident that when complex control laws are to be implemented (such as those investigated in the AFTI program), when several degrees of freedom are to be controlled, when several modes of control are involved, and when one central digital computer is to do all this, then it is difficult to operate in real-time (that of the analog process) without using long cycle times. If 10 ms are required for the software calculation of each axis of the next attitude control update, 10 ms for the display update, and 10 ms for the artificial feel system, then the required cycle time is 50 ms--a sample frequency of 20 frames/second. This isn't fast enough if one dominant mode to be controlled has a natural frequency  $>$  about 2-4 Hz (allowing a margin for aliasing, noise, and other nonideal effects). Regardless of Shannon's sampling theorem, practical experience with real digital control systems (e.g., the C-130 gunship fire control) indicates that a cycle frequency 5 or 10 times greater than the desired bandwidth of control is a



# Contrails

necessity. While analytical techniques for the evaluation of this problem will certainly improve, FCS computational complexity will continue to increase.

The cycle time can be decreased by simplifying the software, getting a faster computer, or giving the CPU fewer things to do.

Software simplifications might be in the nature of truncating an infinite series (e.g., using  $\sin x = x$ , rather than a more generally acceptable calculation) or replacing a numerical integration subroutine with one of lower order/accuracy in the interest of gaining speed of computation. (It is interesting that relatively crude Runge-Kutta algorithms are typically used for performing numerical integrations in modern aircraft simulator design; the reason offered is that this approach is necessary to achieve real-time speed capability! One may be excused for feeling that the art of numerical analysis hasn't successfully infiltrated simulation technology.) Hardware solutions may occasionally have a benefit here. Hardware floating point devices can replace almost all software floating point calculations with a typical time savings of about 50:1; these add to total hardware acquisition and life cycle costs, but may save on the overhead costs of developing and verifying complex software packages.

It isn't in the nature of things to expect that getting a faster computer will provide a lasting solution to any problem related to insufficient CPU time available. State-of-the-art CPU's appear to be fast enough to get the basic job done. The problem is managing their use; someone can always find one more thing for the FCS computer to do. Even a miniaturized CDC 6600 would be hard pressed to do all of the following:

- Implement the basic flight control laws
- Manage the flow of transducer data in and out of the CPU
- Perform guidance/navigation calculations, command and control
- Generate the pilot's display/flight director logic, symbology and dynamics
- Compute data required by the fire control system
- Control the artificial feel system
- Perform system error checking

# Contrails

- Contain the multimode control law functions with automatic suppression of switching transients, etc.
- Perform terminal navigation, guidance, and control for automatic, coupled approach and landing
- Interface the avionics, FCS, and propulsion systems
- Accomplish FCS fault detection and perform redundancy management

In this context, however, it is worth considering that a miniaturized computer in the CDC 6600 or IBM 370 class is forecast for laboratory use by 1981. This is visualized as a baseball-sized unit, cryogenically cooled to near absolute zero, and based on Josephson junction technology. Perhaps within two to three generations of military aircraft, computer technology of this sort can become part of the DFCS and completely eliminate current size and speed limitations.

The development of aircraft and aircraft systems based on the concept of functional integration at the level of hardware design seems to lead naturally to the concept of giving a central computer almost everything to do. There is a modification of this concept, however, that seems quite straightforward and promising, viz., multiprocessing. With a multiprocessing control system, there can be several CPUs. Each may have its own memory and buses or these may be shared. The possibilities for system architectural arrangements are limitless. Each processor could be dedicated to one or a few functions (e.g., longitudinal control or generating fire control displays for the pilot). Each processor is slaved to a master CPU (executive) so that it merely relays synthesized results over a data bus to the executive or to a peripheral device (e.g., to an actuator) when commanded by the executive to do so; during the intervening period between input/output cycles the slave CPU busily acquires new status data and calculates the next output. Such systems could be marvelously efficient. However, there has been relatively little attention given to multiprocessor solutions to the FCS problem. The hardware and software problems may be more complex than those for a simple CPU-however, this is by no means a certainty. The conventional approach to hardware redundancy, however, looks much more difficult within the present state of the art. This may be an area where the concept of fault-tolerant digital systems hardware/software design could provide enormous practical simplification of the redundancy problem.

# Contrails

Now, consider the situation where a pilot applies control inputs in addition to those of the automatic, digital controller of Figure 1. If the pilot is tracking pitch attitude such that the rms value of  $\dot{\theta}$  is equal to  $0.5^\circ/\text{s}$  (a typical value for precision control) then, to continue the example, the ADC would digitize the region from  $-0.5$  to  $+0.5^\circ/\text{s}$  into about 22 discrete segments of  $.043^\circ/\text{s}$  each (slightly less than one milliradian/second). Since the human threshold for visual rate perception is about 1 mr/s, then it is plausible that the pilot would be unaware of the effect of the digital controller so long as the resulting changes in normal acceleration also are not detectable by him. If the computer uses  $\theta$  or  $\dot{\theta}$  information to drive a display, then the discrete changes in  $\theta$  and  $\dot{\theta}$  (as displayed) for successive updates must remain below the pilot's threshold of perception if the handling qualities are not to be degraded. This value may be assumed to be 1 mr/s of arc subtended at the pilot's eye. It is apparent that there is a relationship between the change in successive output steps and the frequency of this output.

The point of these heuristic arguments is to illustrate that a direct relationship can exist between the DFCS designer's choice of hardware, the choice of control laws, their software implementation within the flight control computer, and their impact on handling qualities. What is required of the handling qualities technology at this time is an assessment of these and similar areas of interface between the handling qualities problem and FCS design practices or hardware specifications. Proposed in this report are handling quality requirements which address the DFCS issue as but a first step in this process.

## B. SUMMARY

There are several points where DFCS hardware or software can impact the ultimate handling qualities of the aircraft when used in the intended, operational manner. Some of these are discussed below:

### ADC Resolution

The number of binary digits used to represent an analog signal can have a direct impact on aircraft handling qualities. In general, the smaller the

# Contrails

word length, the less the resolution of the ADC, the coarser the discretization, and the greater the equivalent noise injected into subsequent computations or data analyses by the digital portions of the FCS. In the above example, a 12-bit ADC gives  $2^{12} = 4096$  increments allowable for the analog signal.

The range of the ADC is very nearly arbitrary in many practical applications; it is defined in this report as the maximum minus the minimum values of the signal to be digitized. The range is not an ADC property, per se. It is used only for scaling of the digital signal. The range is traditionally selected so that the probability is small that an out-of-range signal would ever be encountered in practice. The problem is that one can be too conservative. The scaling should be given very careful attention within the context of handling quality considerations. For a given ADC word length, the range should be selected as small as possible to reduce the coarseness of the signal discretization. If the range is large, in fact, due to system dynamics, then discretization errors can be reduced by increasing the ADC word length. The range, together with the ADC word length, uniquely determines the ADC resolution limits.

## Control Roughness

When the period between control command updates (cycle time) by the CPU is too long, the control output spectrum will contain a high frequency content that would not be present in a functionally comparable analog system. This could degrade the handling qualities in much the same way as does turbulence. In effect, the pilot could try to track motions induced by the DFCS. In an extreme case this could lead to amplifications of the motion and even inadvertent departure. Control roughness of this sort could be minimized by keeping the cycle time of the DFCS less than some tolerable level. Also, the use of a first-order sample and hold on the DAC outputs to control actuators might, in some cases, reduce the undesirable high frequency components in the control output spectra.

# Contrails

## DFCS Phase Lag

The pure time delay contributed by a digital controller to system dynamics is, to a first approximation, equal to that of an equivalent phase lag. For a zero-order hold, the magnitude of this delay is one-half that of the digital controller's cycle time. Thus, increasing cycle time (i.e., decreasing the controller update frequency) yields increased total loop phase lag and either reduced bandwidth or decreased loop stability; this occurs independently of any considerations of handling qualities. The impact of this result on handling qualities can be severe when the DFCS cycle time is made less than some value (which is a function of plant dynamics).

When the outputs of a DFCS computer are used to drive a primary display instrument (attitude, altitude rate, flight path angle, HUD flight director, etc.) the DAC and video (or other) interface must be designed with particular care. It is no longer newsworthy to note that display dynamics can, under the proper circumstances, become part of the pilot-vehicle system dynamics loop and, as a result, influence vehicle handling qualities. With a computer generated CRT or HUD the display dynamics can, with one exception, be eliminated. The exception is the equivalent phase lag due to the display update frequency. If this is fixed at too low a rate (e.g., because the CPU is overloaded with control or other functional requirements) then the display will "jitter" unless the DAC output is smoothed. In general, smoothing the display control signals by low-pass filtering must be carefully done; the associated phase lag can severely degrade handling qualities and make precision tracking impossible. More sophisticated signal processing is desirable. This problem appears to provide a natural application for a multiprocessor design. For example, this might consist of a "smart" display that can update itself with high accuracy while the executive CPU is busy with other functions. The function of the executive then becomes one of updating the predictions of the "smart" display. An intelligent display of this sort would be part of a multiprocessor system architecture.

# Contrails

## DFCS ARCHITECTURE

The governing approach to design of a DFCS must account for many factors. This seems particularly appropriate when the DFCS is fully integrated with the display, avionics, fire control, etc. An iterative approach to system design would consider available hardware, the FCS tasks, any governing handling quality considerations that might impact the DFCS, etc. Single vs multi-CPU's should be considered as alternatives. All these factors are interrelated in ways that have only been hinted at in this brief appraisal of the state of the art. The point to be made here is that hardware considerations which, in another context, would be entirely esoteric can have a devastating effect on handling qualities. Such effects must be carefully evaluated during the process of systems specifications development, system design and system prototype evaluation. An example of this might be the CPU instruction set; this is the table of all user commands which, when properly coded into binary (ones and zeros), can be interpreted by the CPU to execute a useful function--such as adding two numbers or fetching a word from a particular address in memory. Each CPU has a unique instruction set. The connection between the CPU instruction set and considerations of handling qualities may seem obscure; one function of DFCS design should be to ensure that the functional connection remains this way. However, if a particular CPU's instruction set should lead to an FCS architecture which restricts system cycle frequency, and if the resulting phase lag sufficiently degrades the handling qualities, then either the CPU or the FCS architectural deficiencies should be identified and, if necessary, changed. It is not sufficient to assume that FCS deficiencies which are identified in flight test can be corrected by changing the controlling software. This probably can't be done, in general; it can never be done successfully when the basic problem is a CPU that can't be driven fast enough to perform the functions demanded of it. Since one does not merely prescribe a faster CPU as a solution, such problems are inherently of an architectural nature. Multiprocessor approaches to the DFCS architectural design problem look especially attractive because they tend to unload the individual CPU and thereby leave a lot of software options for final FCS control law "tweaking" in the flight test phase of a systems development. In this context, standardization on one single airborne digital computer looks like a mistake.

It was previously indicated that for a given CPU and a specified DFCS architecture the software design is restricted by the required system cycle time, or vice versa. The literature is weak in the area of equivalent noise generation by discrete, numerical approximations to continuous systems. However, it is readily apparent that the transfer properties of a digital controller can often be approximated as linear with an equivalent noise component (the describing function approximation). Both the linear element dynamics and the equivalent noise spectrum will be functions of the detailed numerical process mechanics. This may be illustrated by an examination of z-transform models for various simple numerical integration algorithms.<sup>8</sup>

In general, the use of discrete numerical algorithms for implementation of FCS control functions will produce additional dynamics to the FCS that would not be accounted for by examining only the original, continuous dynamics that the digital controller is intended to emulate. The system dynamics are dependent to some extent on the numerical algorithms selected for control law implementation. There is also a clear and very strong connection between accuracy of a numerical process and the speed required for process completion. The rules for speed/accuracy trade-offs in DFCS architectural and software design are obscure. However one may choose to address the problem of software design, the effects of software selection and its implementation within a particular FCS computer on system dynamics, and the handling qualities problem should be carefully evaluated.

The requirements for DFCS redundancy and system error checking may present special difficulty to the handling quality problem--depending upon how this is done. In some past design studies, for example, multiple CPUs "trade" data at the start of each new control cycle. These data are finally averaged for use in later calculations. However, one CPU may be faulty or receive spurious data yet remain on line provided it does not contradict the remaining CPUs for more than a preset number of consecutive cycles. The result is that all control calculations using these data will be degraded because the spurious data are included in the data averages; this might look like noise

# Contrails

injection into the control loop. Problems of this sort may often have an intermittent, hardware origin; they may not be identified by software error checks that were designed for catching the hard-failure condition.

## Intelligent Sensors

There is little evidence in the literature of activity in the development of "smart" sensors. The usual (implicit) notion is that transducer elements will be used to supply raw data to a central computer for implementation of control laws, control of displays, etc. However, with the advent of the microprocessor it is now practical to consider localizing many basic data calculations at the sensor, prior to bothering the executive. This would be true for elementary sensors, such as a linear accelerometer, or for "sensors" that are really complex systems, such as strap-down inertial reference systems. A "smart" inertial reference system, for example, might calculate the actual course and estimate the future course with no closure of a navigation control loop; when it estimates a course deviation greater than a tolerance value, then it interrupts the executive CPU, requests a course correction, and provides an estimate of the control required. The obvious benefit of distributed processing of this sort to basic FCS performance and handling qualities is that more time might be available for the executive CPU to devote to the inner loop control functions. The behavior of these will define the handling qualities problem.

## DFCS Transparency

Aircraft handling qualities are dependent on system functional performance. Ideally, a pilot neither cares nor knows about the hardware or software employed to perform the flight control tasks. The thrust of DFCS design should be to ensure that all such considerations remain transparent to the pilot. The accomplishment of this will require:

- Careful selection and fine tuning of control laws.
- Optimization of the digital system architecture (including selection of the CPU, multiprocessing, etc.).



# Contrails

- Consideration of the effects of software, as implemented in the digital computer, on system dynamics.
- Sophisticated human factors design of computer generated displays and control manipulators.
- Consideration of the impact of analog-to-digital-to-analog hardware specifications and selection on the DFCS performance.
- Consideration of the potential degradation of DFCS performance and handling qualities due to redundancy or error-checking requirements during this portion of executive software design.

The DFCS concept offers enormous potential for both enhanced performance and for colossal error. The problems posed by DFCS design are complex because, at their root, they are systems problems.

The future development of DFCS must adopt a systems approach in which problems peculiar to the airframe dynamics, FCS hardware, software, control manipulators, etc., are all given a balanced treatment. The pilot's role as both a final judge of system quality and as the operator must be considered. To do this, handling quality specifications which address the design requirements for DFCS must be developed. A step toward that end is taken in Section VIII.

# Contrails

## Section IV

### THE ANALYTICAL APPROACH TO HANDLING QUALITIES SPECIFICATION--A CRITIQUE

#### A. THEORY

The field of pilot-vehicle systems analysis--viz. pilot modeling and prediction of system dynamics and performance--was thoroughly reviewed and critiqued in Reference 1. Since then, Onstott<sup>10</sup> has continued his studies of pilot dynamic modeling in two axis tracking. The interesting feature of Onstott's work is its time domain orientation. Hess<sup>11, 12</sup> has continued his studies of the pilot model introduced by Smith<sup>13, 14</sup> and confirmed its value as a tool for unifying the entire base of single axis tracking data and for understanding the character of the classic servo model<sup>3</sup> and the origins of its parameters.

It is noted in References 1 and 9 that neither pilot-vehicle system dynamic response nor system performance necessarily determines the handling quality problem. These things are closely related to vehicle handling behavior. However, the availability of analysis methods that enable the prediction of dynamics and performance of a pilot-airframe-FCS does not lead automatically to the prediction or assessment of what we call handling qualities.

The question of the validity and consistency of subjective rating data for handling qualities was considered in References 1 and 9; it was concluded that there is no basis for believing that Cooper-Harper ratings--properly obtained--are not adequate measures of handling qualities. The philosophy in this report is that pilot opinion rating is the only acceptable, available method for handling qualities quantification. The Cooper-Harper scale has its deficiencies; they are not restrictive so long as the evaluation pilot is well indoctrinated in the use of the scale and an adequate experimental design is provided. These are practical restrictions which create some of the confusion that seems to exist about the validity of pilot opinion as a handling qualities metric.

# Contrails

This philosophy was developed and pursued in Reference 1. A physical theory for pilot opinion rating (and, therefore, handling qualities) was derived from that philosophy. The derivation was founded on years of prior research by many investigators on measuring human dynamics and pilot model development; it was not another ad hoc effort. The theory of Reference 1 is the only physical theory for pilot opinion rating that is known to exist. It suffers from one major, practical restriction: an adequate mathematical model for pilot dynamic response does not exist for exercise of the theory.<sup>1</sup> The optimal control model for pilot dynamics was used<sup>1</sup> with some success for the analysis of existing data; however, the lack of a universal cost functional severely restricts the use of the optimal control model for handling qualities prediction for aircraft with nonclassical dynamics.

## B. EMPIRICAL

There exist several methods for handling qualities prediction that are, in essence, empirical with ad hoc origins. The better known of these are:

- C\*<sup>15</sup>
- TRP<sup>16</sup>
- CAP<sup>17</sup>
- Neal-Smith Criterion<sup>6, 20</sup>
- McPilot<sup>18</sup>
- Paper Pilot<sup>19</sup>
- Mayhew<sup>21</sup>

The first three are time response methods; they relate handling qualities to parameters of aircraft time response. The others are frequency response methods; they use a model for pilot dynamics, perform a loop closure and use the results for handling qualities prediction. [Reference 20 contains an open-loop, aircraft-only version of the original closed loop criterion of Neal and Smith.] McPilot is based upon Anderson's Paper Pilot concept; the latter was reviewed in Reference 1 and won't be considered further in this report. Mayhew's work is a modification of that of Neal and Smith; he employed the equivalent short-period model for aircraft/FCS dynamics and developed a set of revisions to the short-period dynamic requirements of

# Contrails

MIL-F-8785B. He also eliminated pilot dynamic parameters from his reformulation of the requirements; the results are given in a format much like that of MIL-F-8785B but with a data base that includes higher order system dynamics. He adds one more parameter: time delay. Earlier references to Mayhew's work exist; that contained in Reference 21 is the most topical and the most readily available.

Tobie et al.<sup>38</sup> developed C\* boundaries corresponding to the Cornell Aeronautical Laboratory "bullseye" boundaries of frequency and damping ratio. These were later revised by Kisslinger et al.<sup>44</sup> Reference 6 contains a critical evaluation of C\* based upon extensive flight test data. Coursimault<sup>22</sup> also evaluated C\*. In each reference, it was concluded that the C\* version investigated was not an adequate basis for the prediction or specification of handling qualities. The Neal-Smith criterion has been evaluated by Coursimault,<sup>22</sup> Mayhew,<sup>21</sup> and Brulle and Moran;<sup>25</sup> the results are inconclusive. One difficulty with this criterion is that an a priori specification of pilot-aircraft system bandwidth must be made. In some cases, the resulting prediction of handling qualities is very sensitive to the bandwidth selection. Examples of this are given by Mayhew.<sup>21</sup> There is ample evidence that closed loop bandwidth is not a parameter that can be specified on any a priori basis. One of the principal results of Reference 3 was to show that bandwidth is systematically dependent upon controlled element dynamics and the spectrum of disturbance input. There is no provision in the theory of References 6, 20, or 21 to account for this dependence of bandwidth on aircraft dynamics or turbulence spectrum. It is also true that turbulence properties, per se, are not accounted for in this theory. Mayhew's justification for use of this approach for the development of handling qualities specifications is that the theory is to provide only a guideline for the collection and interpretation of handling qualities data. In his view, the specification of short period dynamics, for example, would be revised by increments as new data become available; the Neal-Smith-Mayhew model would serve this revision process in bootstrap fashion. Thus, the theory would be used primarily as a sophisticated curve fitting technique.

# Contrails

The use of any theory--sophisticated or crude--for the basic purpose of data interpolation or extrapolation can only be justified for handling qualities specification development if a sizable data base exists, or the theory is based upon physical principles and is not ad hoc in character; for such a theory, a minimum of supporting data are required.

It is already apparent that the acquisition of handling qualities data will probably continue to lag systems development; regardless, there never seem to be sufficient data. It is also questionable whether advanced aircraft-FCS can be parameterized in some way that would permit convenient and acceptable updates of MIL-F-8785B. There exists, however, a social phenomenon that might be called the "equivalent systems juggernaut" that has attracted a substantial following.

Briefly, the equivalent systems concept is as follows:

- (1) An aircraft control-response relation that is describable with a differential equation of order  $n$  can be described in some sense with a differential equation of order less than  $n$ .
- (2) For short-period aircraft pitch attitude response, the equivalent systems model is

$$\frac{\theta}{F_S}(s) = \frac{K_{\theta} \left( s + 1/T_E \right)}{s \left[ s^2 + 2\zeta_E \omega_E s + \omega_E^2 \right]} e^{-\tau_E s}$$

This form was selected so that in the limit as the system dynamics due to control augmentation become of sufficiently high bandwidth the model reduces to that of a classic aircraft with no contribution of controls to the short-period dynamics, i.e., to

$$\frac{\theta}{F_S}(s) = \frac{K_{\theta_0} \left( s + 1/T_{\theta_2} \right)}{s \left[ s^2 + 2\zeta_{sp} \omega_{sp} s + \omega_{sp}^2 \right]}$$

# Contrails

- (3) The effect of higher order system dynamics, due to the control system, at frequencies of interest to manual control is therefore embodied in
- $\tau_E \sim$  the equivalent system time delay
  - modification of the airplane-only short period parameters  $T_{\theta_2}$ ,  $\zeta_{sp}$ , and  $\omega_{sp}$ .
- (4) Four parameters ( $T_E$ ,  $\zeta_E$ ,  $\omega_E$  and  $\tau_E$ ) are required to represent the pitch attitude dynamics of any higher order system--versus three for the classic airplane (for which  $\tau_E$  has either been ignored or is negligible).
- (5) If the requirements of MIL-F-8785B for short-period dynamics are reformulated in terms of the classic parameters, then the addition of the fourth parameter ( $\tau_E$ ) required for the equivalent system model can be easily accommodated without further qualitative revision to the format of MIL-F-8785B.

Mayhew's recommended revisions<sup>21</sup> follow precisely this philosophy. A good summary of the equivalent systems approach is contained in Reference 24.

The value of the equivalent systems model is purported to be that it is applicable to aircraft-FCS dynamics of any order. While it is true that the model can be fitted to arbitrary dynamics of higher order, it is by no means clear how this will assist in the resolution of the handling qualities problem for aircraft of these sort. We repeat:

- The capability for predicting or measuring aircraft or system dynamics does not imply that estimates of handling qualities will necessarily follow.

Two intrinsic difficulties with the equivalent systems concept are: (1) How does one uniquely determine its parameters, given higher order system dynamics? Is uniqueness necessary, in fact? (2) Are handling qualities

# Contrails

uniquely defined by pitch attitude dynamics? Do we require supplementary equivalent system parameters for normal acceleration or other responses to complete the description?

There are various schemes used for determination of the equivalent system parameters; each can yield significantly different results. There is no standardized method for selection of the model's parameters. One approach is to fix  $1/T_E = 1/T_{\theta_2}$  (the airframe-alone value) and then select the remaining three parameters to minimize the fit error in some sense. The results can be qualitatively different (in terms of handling quality implications) than those obtained with all parameters free. An even more troublesome condition occurs when the control system dynamic effects do not dominate the aircraft dynamics, but the aircraft response is nonclassical. This is known to occur for the F-15 in asymmetrical flight conditions (e.g., in a wind-up turn).<sup>4</sup> The F-15 has what appears to be the usual short-period and phugoid modes. However, a new mode exists that appears to result from lateral-directional coupling. The frequency of this mode is not much greater than that of the short-period. There is no evidence that this mode necessarily degrades longitudinal handling qualities. In order to apply the equivalent systems model to dynamics of these sort, either the model or the fitting rules would have to be changed; otherwise the fit errors might be gross.

It is recognized that a clever analyst can always find a path around obstacles of these sort. Still, it is difficult to see how, in the absence of a unifying theory, such problems can be broadly addressed for resolution of the problems of MIL-F-8785B.

The PIO theory of Reference 2 and the stick pumping theory of References 13 and 14 emphasize the importance of normal acceleration as a piloting cue—at least for those tasks where path control is critical to task performance. Also, with modern HUD concepts or integrated display-FCS the pilot may have no pitch attitude cue. The usual application of the equivalent systems model contains no provisions for handling qualities analysis of such conditions. Dual models for both pitch and normal acceleration dynamics have

# Contrails

apparently been tried for limited studies with some success (McDonnell-Douglas) but the work is unpublished. If two such equivalent system models are required to satisfactorily address longitudinal dynamics and handling qualities, then the impact on specification development is serious; eight parameters would be required, in general, plus standardized rules for parameter estimation and a sizable data base to establish the handling qualities connection. Surely a more direct approach to the problem is possible.

The equivalent systems approach to modeling higher order system dynamics may create as many problems as it solves. It is conceivable that handling qualities prediction methods based upon the philosophy can be devised and that these can be used to support airframe or FCS design trade-off analyses; this may even have been done already, on a proprietary basis. However, such methods are artistic and ad hoc in character; this situation will not change until the true handling quality parameters are identified. It is difficult to imagine that methods based on the equivalent systems concept, given the current state-of-the-art, can be satisfactorily implemented to update MIL-F-8785B.

The complexity posed by frequency response methods, in general, makes time response methods look especially attractive by comparison. Abrams' TRP (time response parameter) is evaluated in Reference 23 where it is concluded that, for inexplicable reasons, the method seems to work surprisingly well; it is, however, not applicable to those cases where the aircraft step response is overdamped with zero dead time.<sup>23</sup>

Reference 23 reviews most of these and other handling qualities methods against a data base obtained during the F-15 development. It was concluded that no existing single criterion will suffice for the prediction of aircraft handling qualities.

It should be noted that analysis methods based on the Neal-Smith criterion and C\* are in routine use at various companies to develop flight control systems for real airplanes. There is a clear and pressing need for methods of this character. The simplicity of the time response methods, in particular, has a tremendous appeal for use in design studies.



# Contrails

The time response methods (TRP, C\*, CAP) are based on intuitive notions about what features of aircraft response to control are desirable. The general success of these methods is an indication that parameters such as rise time, overshoot and dead time may indeed be closely related to a pilot's opinion rating. However, the connection that will link the physical problem with the tools of rational analysis has yet to be made; an attempt to do so will be made in the next section.

## C. SPECIFICATION DEVELOPMENT

Let us imagine that one or all of the above methods proposed for handling qualities prediction is completely successful. How, then, would this prediction technique be implemented to develop a better flying qualities specification? There is no obvious answer; the problem is technically complex and embraces important nontechnical issues.

It cannot be emphasized too strongly that the specification of aircraft design requirements for acceptable handling qualities is an altogether different problem from that of designing an aircraft to have acceptable handling. We recognize that this is not a popular viewpoint; however, the prevailing alternative viewpoint is responsible for much of the current specification dilemma for advanced FCS.

Any method is acceptable for the design and development of an aircraft-FCS so long as it leads to acceptable results. This is not a tautology. Any design approach will entail a certain number of iterations. Thus, methods for handling qualities prediction such as the Neal-Smith criterion, C\* or TRP can all serve a useful function in the design process if they enable the transition of a FCS from the pencil and paper stage to hardware development.

One danger in using analysis methods such as these for systems design is that candidate FCS designs that might have real merit to system performance enhancement, reliability, cost, or handling qualities may be thrown out because of deficiencies in the analysis method. Poor systems may also be retained; these however, will (or should) be so identified later in the

# Contrails

design cycle--perhaps in the simulation stage. Examples of both cases are given by Coursimault<sup>22</sup> and by Neal and Smith.<sup>6</sup> There is a definite overhead involved, therefore, with the use of handling quality tools that are lacking in baseline precision. So long as the next generation of FCS looks much like the last, then the design methodology may not be all that crucial to the result.

For design acceptability an engineering specification must be right in an absolute sense. It is true that MIL-F-8785B is a design guide of sorts (it all depends upon one's concept of a design guide). But to view it only in those terms is to ignore the reasons why such specifications exist at all. The intent of MIL-F-8785B is to provide the desired functional performance of the pilot-vehicle system. This, however, is not easily done in any direct quantitative sense without prior identification of a physical, measurable description of handling qualities. [The U.S. Army specified for the Wright Flyer, Model B that its flying qualities be safe and satisfactory for completion of the intended mission.] There is, as yet, no satisfactory measure for handling qualities other than pilot opinion rating; but that, for reasons that are well known, is not an acceptable metric for use in a design specification.

The philosophy of MIL-F-8785B rests upon the implicit use of pilot opinion rating to "map" airframe dynamic parameters into regions of acceptable or unacceptable handling qualities. This approach has never been entirely successful; exceptional cases, at both extremes, which violated MIL-F-8785B and its predecessors have always existed. The relationships between handling qualities and modal response parameters of the classic aircraft ( $\zeta_{sp}$ ,  $\omega_{sp}$ ,  $L\alpha$ , etc.) have been empirically derived with some general guidance from the technology of pilot-vehicle systems analysis. The problem, in essence, is that a reliable method for the prediction of pilot opinion rating has not existed.<sup>1</sup>

The art of pilot-vehicle systems analysis was developed in response to a clear need to predict troublesome handling qualities problems and develop design specifications to avoid them in practice. It is therefore ironic that

# Contrails

the analytical approach to handling qualities has had so little impact on the handling qualities state of the art. Reasons for this state of affairs are complex and many; those that bear on the philosophy of research in this problem area are discussed in Reference 1.

## D. THE METHOD OF REFERENCE 1

Reference 1 presents an analytical approach to the formulation of handling quality specifications. The approach proposed was straightforward:

- (1) Develop a refined model for pilot dynamics which is capable of unifying the loose ends of the available data base and which eliminates the mystique of the "adjustment rules" of Reference 3.
- (2) Establish a rational connection between this model and pilot opinion rating; use this as a basis for a physical theory for handling qualities.
- (3) Map aircraft-FCS parameters into regions of acceptable and unacceptable handling qualities in a manner similar to the format of MIL-F-8785B.

A metric for the correlating and prediction of pilot rating was devised in Reference 1 for the control task of pitch attitude stabilization. The key to the success of this work was the realization that state-of-the-art models for pilot dynamics are deficient in both philosophy and application. The character of the required pilot model was presented; it could not be suitably parameterized with the time and resources available for use as a tool for engineering analysis. The principal product of Reference 1 was a critical perspective on the nature of the pilot as a controller. In lieu of a unified model for pilot dynamics, the application of the concept proposed for the prediction of POR requires use of the optimal pilot model. This, for reasons discussed in Reference 1, is a hard limit on the practical utility of the method for handling qualities prediction. This model is structurally depicted in Figure 2 for the case of single axis control of pitch attitude. The

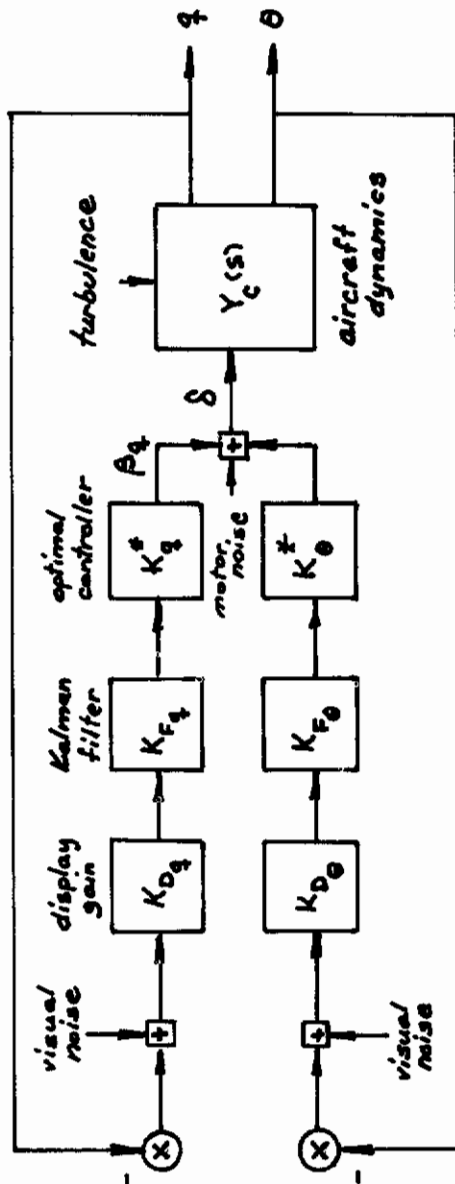

$q = d\theta/dt$   
 $K_{Dq} \ \& \ K_{De}$  ~ visual input modality describing functions  
 $K_{Fq} \ \& \ K_{F\theta}$  ~ Kalman estimator gains  
 $K_q^* \ \& \ K_\theta^*$  ~ optimal controller gains; chosen to minimize  
 $J = J(\sigma_\theta, \sigma_q, \sigma_\delta)$

Figure 2. Pilot-Vehicle System Model for Pitch Tracking in Turbulence

# Conclusions

signal  $\beta_q$  is an abstract representation of the response of the central processes (cortex, thalamus, etc.) to error rate; it is a command to the neuromuscular system and is therefore representative of that portion of the pilot's control response devoted to the control of errors in attitude rate. For reasons that are completely explained in Reference 1, the rms value of the signal  $\beta_q$  is hypothesized to vary directly with Cooper-Harper rating for continuous tracking tasks; confirmation of this hypothesis is given by Figure 3. These results, from Reference 1, were obtained by using the optimal pilot model to predict  $\sigma_{\beta_q}$  for the configurations tested by Arnold;<sup>7</sup> these same cases had been flight tested earlier by Neal and Smith.<sup>6</sup> It was concluded in Reference 1 that the variation of  $\sigma_{\beta_q}$  with Cooper-Harper rating shown in Figure 3 constitutes a "calibration" which may be used for the prediction of pilot rating for single axis pitch tracking for any aircraft or FCS dynamics.

The power of the method proposed in Reference 1 is its foundation on physical principles and, hence its universality. The method is not restricted by aircraft or FCS dynamics; it applies equally to classic or nonclassic, linear or nonlinear system dynamics. The functional relation between Cooper-Harper ratings and  $\sigma_{\beta_q}$  is hypothesized to represent a first approximation to a psychophysical continuum. This function provides a basis for the development of design specifications for short-period longitudinal handling qualities, as follows:

## Classic Aircraft-FCS Dynamics

$$\frac{\theta}{F_s}(s) = \frac{GM_{\delta e} (s + 1/T_{\theta_2})}{s(s^2 + 2\zeta_{sp}\omega_{sp}s + \omega_{sp}^2)}$$

## The Visual Loop

- (1) Use the optimal control model for representation of human pilot dynamics; the appropriate model structure is that of Figure 4.

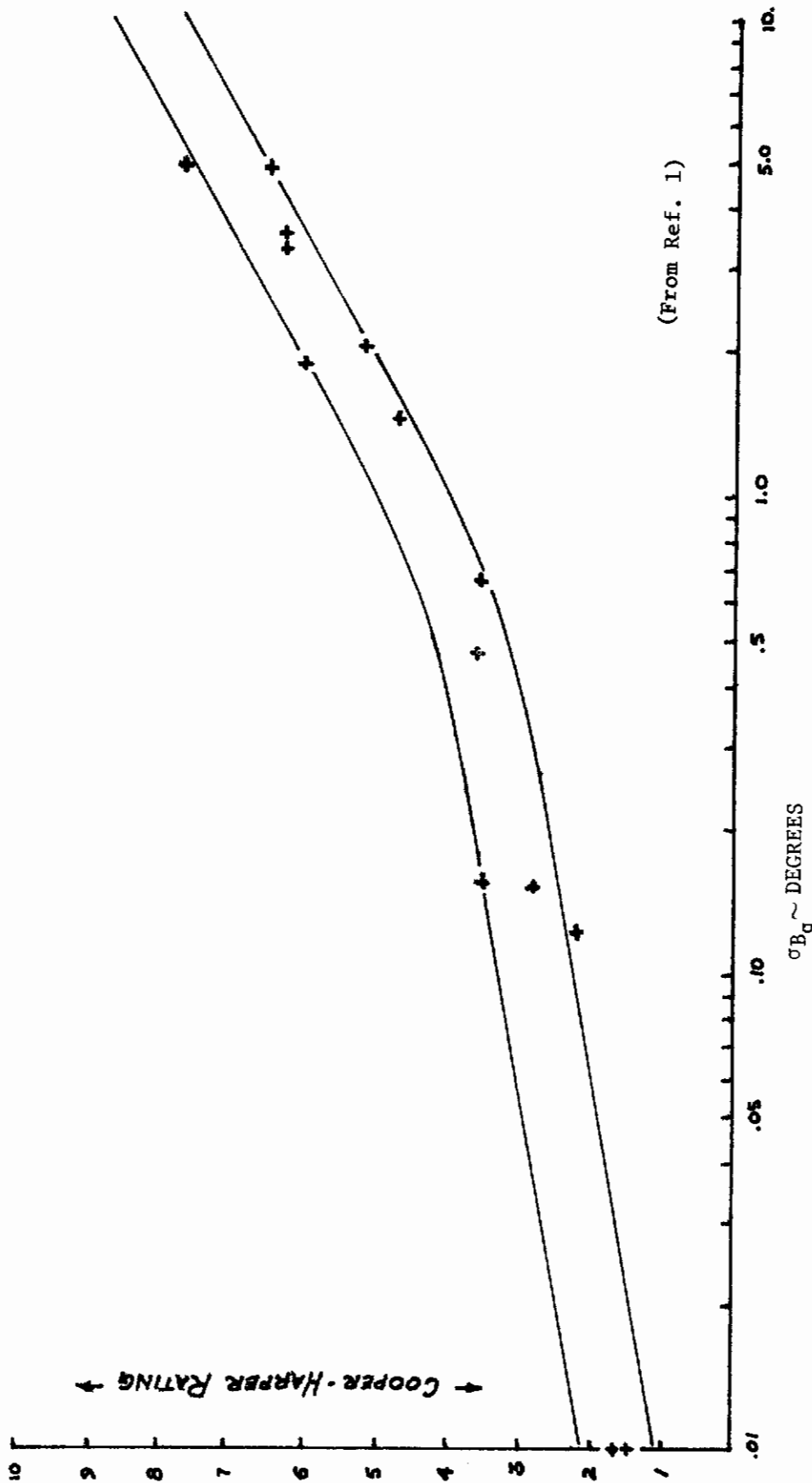

(From Ref. 1)

Figure 3. The Pitch Control Handling Qualities Metric

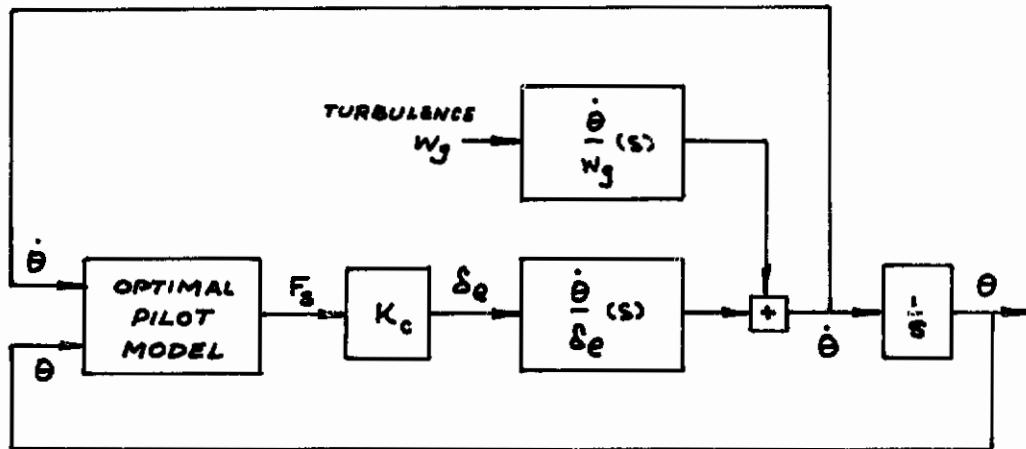

$$\dot{\theta} = q$$

$$\frac{q}{\delta_e}(s) = \frac{M_{\delta_e}(s + 1/T_{\theta z})}{s^2 + 2\zeta_{sp}\omega_{sp}s + \omega_{sp}^2}$$

The pilot model controller gains are selected to minimize the cost functional,  $J = J(\sigma_{\theta}, \theta_q, \theta_{\delta_e}^2)$

Figure 4. Pilot-Vehicle System Dynamics Model for Short-Period Pitch Attitude Control: Classic Aircraft-FCS

# Contrails

- (2) Use the cost functional

$$J = 70 \sigma_{\theta}^2 + 7 \sigma_q^2 + R \sigma_{\delta_{es}}^2$$

This cost functional and the rationale for choice of R are based upon the work of Dillow and Picha.<sup>45</sup>

- (3) Vary the mode parameters  $1/T_{\theta_2}$ ,  $\zeta_{sp}$ , and  $\omega_{sp}$  in systematic fashion. For each combination estimate  $\sigma_{\beta q}$  using the optimal pilot model; from this estimate pilot opinion rating from Figure 3.
- (4) Vary turbulence intensity if the effects of turbulence are to be incorporated into the design requirements of MIL-F-8785B.
- (5) Cross-plot the results in any desired manner to define the Level 1, 2, and 3 regions of handling qualities. If  $1/T_{\theta_2}$  is substituted for  $n/\alpha$  then revisions to MIL-F-8785B could be made to closely follow the current format (paragraphs 3.2.2.1.1 and 3.2.2.1.2).

## The Motion Loop

The above approach to specification development directly treats only the visually controlled pitch response dynamics. Kinesthetic cue effects are implicitly ignored since the method is based upon a treatment of the Arnold<sup>7</sup> data base which was obtained from fixed-base simulation. [The effects on handling qualities of motion cues ( $\ddot{\theta}$  and  $a_{z_p}$ ) are embodied in the parameters  $n/\alpha$  and  $CAP = \omega_{sp}^2/n/\alpha$  in MIL-F-8785B.] It is proposed that the concept of the essential role of motion cues in handling qualities, presented in Reference 2, be used to modify handling quality boundaries derived for MIL-F-8785B derived from considerations of visual tracking alone.

There is considerable appeal to any method that permits the classification of handling qualities according to the separate effects of visual and motion cues. If this can be done for classic aircraft dynamics, then the extension to advanced FCS with decoupled modes may be very natural.



# Contrails

(a) No motion cue effects;  $\zeta_{sp} = \text{constant}$

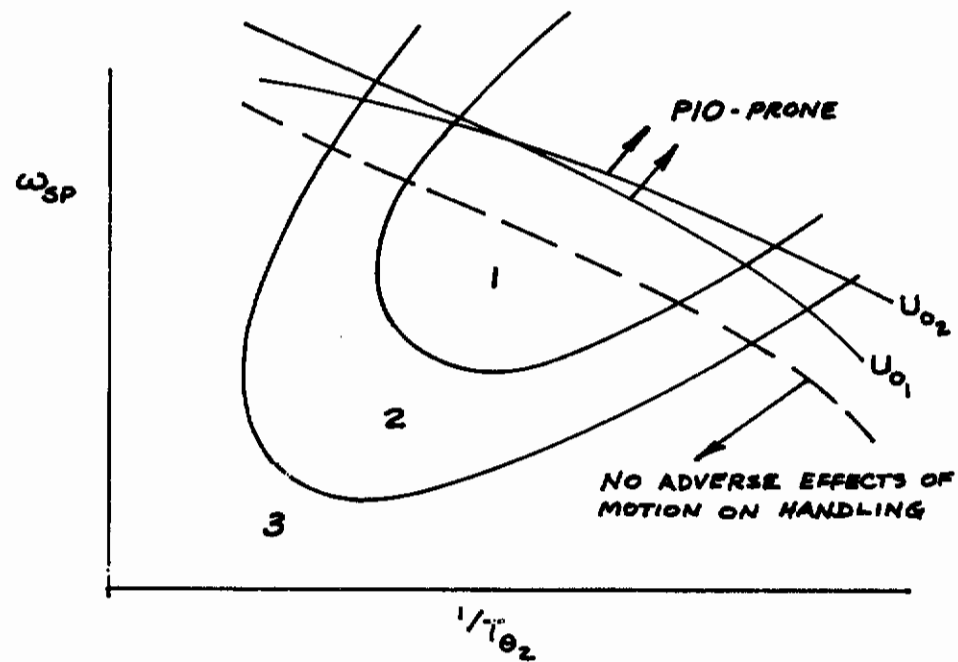
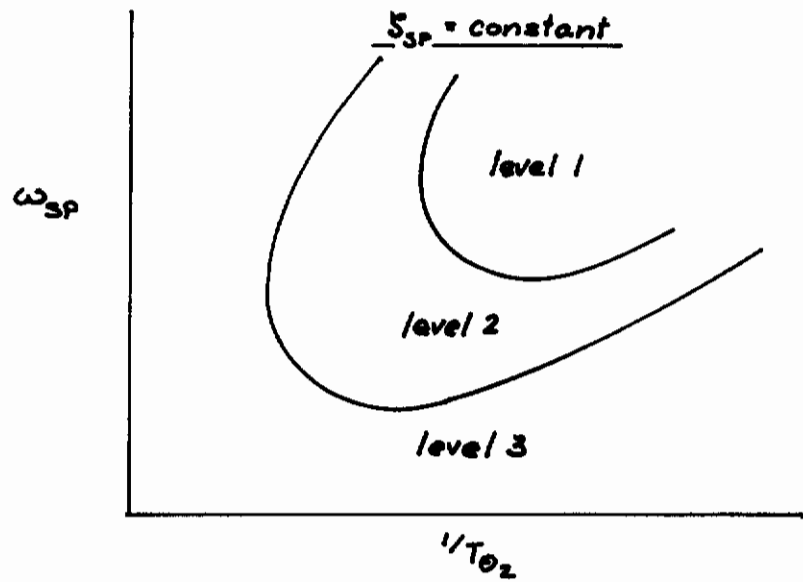

(b) Boundaries Imposed From PIO Requirements

Figure 5. Handling Quality Requirements Derived From Pilot-Vehicle Systems Analysis (Schematic Only)

Figure 5a is a schematic depiction of short-period handling quality boundaries that could be obtained by the procedure outlined above for visual, fixed-base tracking. The choice of parameter space is arbitrary and is only for the purpose of discussion. Each point of the figure has an associated set of closed-loop pilot-aircraft dynamics; these can be estimated through use of the optimal pilot model.

For those parameter configurations that produce a sufficiently resonant closed loop, the method of Reference 2 can be used to identify regions where PIO would be a potential problem. Note that this is only possible because of the unique relation between  $\theta$  and  $a_{z_p}$  response dynamics for a classic airplane at a given speed  $U_0$ ; that is, the parameters that establish the  $\theta$  response will also establish the  $a_{z_p}$  response dynamics since for classic airplane dynamics

$$\frac{a_{z_p}}{F_s}(s) \approx \frac{sU_0/T_{\theta_2}}{s + 1/T_{\theta_2}} \times \frac{\theta}{F_s}(s)$$

The essence of the PIO analysis method is that the  $a_{z_p}$  loop dynamics must be stable at a crossover frequency equal to the pitch loop resonance frequency, including pilot dynamics. Thus, the no-motion boundaries of Figure 5a would, themselves, be bounded by the requirement that no PIO tendencies exist. [The PIO specification proposed by Smith<sup>2</sup> and published in Reference 21 accomplishes this same result for any airplane dynamics.] A PIO boundary could then be superimposed on the no-motion requirements; this is illustrated in the sketch of Figure 5b; note that the PIO boundaries are speed dependent.

In general, motion can degrade handling qualities without necessarily producing PIO tendencies. It is plausible to hypothesize that if zero or negative phase margin of the  $a_{z_p} \rightarrow F_s$  loop at the resonance frequency of pitch attitude loop closure leads to PIO tendencies, then for sufficiently positive phase margin at an appropriate  $a_{z_p} \rightarrow F_s$  bandwidth, motion cues should not degrade handling qualities obtained from fixed-base simulation. Thus, a motion cue boundary might be superimposed on the basic attitude

# Contrails

control dynamic requirements as illustrated by the dashed curve in Figure 5b; this motion boundary is also speed dependent. The "appropriate"  $a_{z_p} \rightarrow F_s$  bandwidth would be equal to the crossover frequency for pitch attitude control.

This approach to the categorization of the effects of motion on short-period handling quality requirements will be further examined in Section VI where will be shown that sufficient flight test data exists to support the hypothesis that the phase properties of  $a_{z_p}/F_s$  can be used to determine whether motion degrades basic short-period handling qualities in the manner of Figure 5b.

## Higher Order System Dynamics

The method described above for the prediction of handling qualities applies equally well to classic or nonclassic aircraft-FCS dynamics; its accuracy is limited only by the validity of the concept on which it is based and by the accuracy of the  $POR(\sigma_{\beta q})$  "calibration" of Figure 3.

If one accepts the validity of the method of Reference 1, then the difficulty posed by nonclassic dynamics is really only one of specification format. There is no obvious best way to define the dynamics of a higher order system in a manner that is completely general and suitable for use in an engineering design specification. However, if the equivalent systems concept is accepted then the method is, in principle, easily applied to accommodate higher order system dynamics.

It is reiterated that the equivalent systems model has absolutely nothing to do with handling qualities, per se. It is merely a device for the approximation of higher order system dynamics with a near-classical form. The problem of relating handling qualities to the equivalent system parameters is unchanged from the classical case except that there is now one additional parameter to be considered--the equivalent time delay. The current popularity of the method is that it is purported to enable the retention of almost all of the current specifications of MIL-F-8785B.

The above method, extended to the case of nonclassical dynamics, is as follows:

## The Visual Loop

- (1) Use the equivalent systems concept as a means for standardizing the aircraft-FCS pitch attitude dynamics in a canonical form, i.e.,

$$\frac{\theta}{F_s}(s) = \frac{K_\theta (s + 1/T_E)}{s (s^2 + 2\zeta_E \omega_E s + \omega_E^2)} e^{-\tau_E s}$$

The equivalent system parameters  $\zeta_E$ ,  $\omega_E$ ,  $T_E$ , and  $\tau_E$  are to be derived in any convenient manner in order to obtain a best fit, in some frequency domain sense usually of the actual transfer function.

- (2) Estimate pilot opinion rating as a function of the equivalent system parameters exactly as was proposed above for classic dynamics; there is now one additional system parameter-- $\tau_E$ .

## The Motion Loop

The effects of motion cues on handling qualities and handling quality requirements cannot be accommodated in precisely the same way as was suggested for the classical condition. The difficulty is due to the lack of any canonical relation between the transfer functions  $\frac{\theta}{F_s}(s)$  and  $\frac{a_{z_p}}{F_s}(s)$ ; that is  $\omega_E$ ,  $\zeta_E$ ,  $\tau_E$  from  $\frac{\theta}{F_s}$  may not give a good fit to  $\frac{a_{z_p}}{F_s}$ . When  $\frac{\theta}{F_s}(s)$  is approximated with the equivalent system model then, in general, this approximation contains no information about the  $a_{z_p}$  response dynamics.

It has been suggested (privately) that two equivalent systems models be used to simultaneously fit both  $\theta$  and  $a_{z_p}$  dynamics. This author is not enthusiastic about further complicating an already cumbersome approach to the development of design specifications. This approach would require as many as nine independent parameters for the description of short-period dynamic response if nonsingle point control systems are to be admitted.

It is worth noting that the possible degradation of handling qualities due to normal acceleration cues could be entirely ignored provided that the PIO criterion of Appendix 1 is enforced. That approach would permit the use of the equivalent systems model for pitch response and avoid any additional requirement for approximating normal acceleration dynamics. Any specification devised with that approach would, however, be unable to identify short-period dynamic configurations that have unacceptable handling qualities due to the effects of motion but which are not PIO prone. It is not a recommended approach.

Requirements for Aircraft Class  
or Flight Phase Category

The above approach for the use of the tools of pilot-vehicle systems analysis for development of handling quality specification provides no obvious mechanism for discrimination of effects due to vehicle class or flight phase category. The method is based upon the functional relation of Figure 3 between POR and  $\sigma_{\beta q}$  which strictly applies to Class IV, Category A conditions. It is presumed that the approach could accommodate all classes and categories by modification of:

- the POR ( $\sigma_{\beta q}$ ) curve--as by new, extended simulation experiments,
- the cost functional J, or,
- the equivalent input thresholds to the pilot model.

Any of the above could account for the various piloting requirement specifics associated with flight phase or class. There is no available method for the implementation of these notions at the present time; it is uncertain whether this could be successfully accomplished using the optimal control model. The cost functional selection involves sufficient black magic already; it may not be practical to modify it at the level of detail required to obtain the required resolution for the prediction of subtle handling quality effects such as would be required for the discrimination of Class or Flight Phase requirements.

If this approach to specification development is to be pursued, then considerable research will be required to develop methods tailored to the resolution of the effects on handling qualities of aircraft size, weight, cockpit architecture, feel, and manipulator properties, and specific task requirements. This is no easy matter.

## E. A ROLE FOR PILOT-VEHICLE SYSTEMS ANALYSIS

For the conduct of pilot-vehicle systems research or even for the engineering design of an aircraft or FCS, matters of style and personal taste can dictate how one chooses to visualize and model the human pilot's role as an element in the system's dynamics. This is not a satisfactory basis for the development of design specifications for aircraft handling qualities. The rules of engineering conservatism must apply, and the community of buyers, manufacturers, and users should all agree on the validity of the specifications to be imposed on the system design. In a practical sense this almost requires that any proposed handling quality specifications be independent of all references to pilot modeling.

The role of pilot-vehicle systems analysis should be carefully evaluated for any applications to the development of handling quality specifications. The viewpoint of this author is expressed in the PIO specification based upon the theoretical development of Reference 2 (summarized in the Appendix). The study of pilot-aircraft system dynamics enabled the derivation of a physical theory for the PIO phenomenon. Thus, the theory of PIO is independent of the analysis methodology or philosophy from which it is derived. The physical theory for PIO was then translated into a specification for engineering design. The validity of this or any other specification derived from a physical principle can be verified from a dedicated flight test experiment. A physical theory of this sort--once validated with reliable data--is independent of the analysis methods with which it originated. This is in complete contrast with the Paper Pilot concept and, to some extent, with methods which have employed the equivalent systems concept.

# Contrails

We conclude, therefore, that handling quality specifications should be independent of pilot-vehicle systems analysis methodology; these are merely a means to an end. The tools of analytical handling qualities may be used to understand or correlate data and to aid in the design of experiments; however, their only real use for the support of specification development is to assist (bootstrap) in the evolution of physical principles on which what we choose to call the handling qualities technology is based.

An analogy may serve to illustrate the point. Consider that Newton never existed; Kepler's laws would remain valid for the two-body condition but the extent of their validity would be unknown. How, then, would one propose to plan and conduct a lunar landing? It could be done, but at greatly increased risk and uncertainty. Simulation, for example, would seem all but impossible.

As a further illustration, consider that one of the established rules of thumb of analytical handling qualities requires that the pitch attitude response resemble  $K_c/s$  in the vicinity of the pilot-vehicle system crossover frequency if handling qualities are to be optimum. There are substantial data to support this criterion. There is probably also a physical basis for it--but that hasn't been determined. As a result, we are unable to say whether it should be the amplitude, the phase properties, or both, of the aircraft dynamics that should most closely resemble  $K_c/s$ ; also, there is no clear basis for quantifying how "close" to  $K_c/s$  the dynamics should be to avoid degraded handling qualities. We have no physical principle to establish precisely why the form  $K_c/s$  has some distinct attribute to handling qualities. In the practical world of airframe and flight control system design, criteria of this sort are of no more than modest value. Usually, a penalty must be exacted if system dynamics of this form are to be achieved.

## F. CONCLUSIONS

- (1) The approach outlined above in Paragraph D appears to be feasible in concept, but troublesome to implement directly:

# Contrails

- (a) It relies upon the use of the optimal control model for pilot dynamics. The validity of this model is highly conjectural; there is no physical basis for presuming the pilot to be an optimal controller. We can't even agree on what "optimal" means. The use of the model in past work has been in the nature of a sophisticated curve fit technique--no matter how well-disguised this may have been. In its present form, the model is probably overparameterized. However, as was demonstrated in Reference 1, if one has data and a physical theory, then the optimal control model may be a satisfactory tool for quantifying the theory. It was concluded in Reference 1, in fact, that the optimal pilot model is the only state-of-the-art model capable of general use for the prediction of pilot opinion rating via the physical theory of that report.
  
- (b) A minimum of four parameters are required for the definition of pitch attitude dynamic requirements in terms of the equivalent systems model for higher order system dynamics. These requirements must be further modified to account for normal acceleration effects on handling qualities. The method proposed may require more data than exists and also require the extension of the equivalent systems concept to address normal acceleration dynamics if advanced FCS requirements are to be generally covered by specification.
  
- (c) The equivalent systems approach to the canonical treatment of higher order system dynamics requires a standard method for its implementation. There is no standard for the derivation of equivalent system parameters as yet. For aircraft in asymmetric flight, coupling between longitudinal and lateral-directional dynamics can create new dynamic modes that could not be fitted with the equivalent systems model as it now exists.



# Contrails

- (2) Time domain models for the specification of handling qualities have a certain visceral appeal--especially after wading through the complexities of frequency domain analyses. However, there is no physical basis for any of these other than an instinctive belief that some balance must exist among  $\theta$ ,  $\dot{\theta}$ ,  $\ddot{\theta}$  and  $a_{z_p}$  time responses. The limited success of C\* and TRP as correlators of pilot opinion rating suggests that a physical principle may indeed exist which, when properly applied, will yield a universal time response criterion for handling qualities. At present available time response methods lack the universality required for use as design requirements; they may however, be very satisfactory for the preliminary design studies required for FCS development.
  
- (3) The approach outlined in Paragraph D is, excepting for its incorporation of motion cue effects, the practical equivalent of that proposed by Mayhew,<sup>21</sup> based upon the Neal-Smith criterion.<sup>6</sup> The underlying concepts are greatly different but, in view of the limited handling qualities data available, both methods would yield similar results when reduced to a specification format since both must be exercised against the same, limited data. For this reason, plus a general concern with the uncritical application of the optimal pilot model to the development of specifications, this approach was discarded during the course of this work.
  
- (4) The greatest single deficiency with MIL-F-8785B, with the equivalent systems model, with the time domain models for handling qualities, and with almost all analytical approaches to specification development is the failure to consider cue requirements of the pilot versus task. MIL-F-8785B, we believe, has scrambled the requirements for pitch attitude with those for normal acceleration through the use of  $\omega_{sp}$ ,  $\zeta_{sp}$ ,  $n/\alpha$ , and CAP all in the same specification statement. One would be well advised to study the separate effects of these degrees of freedom when the task requirements suggest that one may dominate the other, in the pilot's mind, if the control task is to be satisfactorily performed. For advanced

# Contrails

FCS where these modes are, in fact, decoupled it is vital that this be done.

- (5) It is proposed that, where possible, we return to the basics, search for the dynamic and static motivations for pilot opinion rating, and quantify these against known criteria or data. If this search is successful, then a physical basis will have been established for the development of handling quality requirements for any FCS. That is the approach followed in the remainder of this report.

## Section V

### A UNIFIED, ANALYTICAL APPROACH FOR HANDLING QUALITIES SPECIFICATION DEVELOPMENT

#### A. BACKGROUND AND THEORY

The theory of Smith<sup>1</sup> provides the necessary physical and mathematical basis for the prediction of pilot opinion rating. The purpose of this section is to show specifically how this theory may be implemented to develop specifications for the update and revision of MIL-F-8785B. It is generally true that the development of engineering specifications for something so elusive as handling qualities has been an art form. We seek here to employ art to the limits of our capability and ingenuity so that the fruits of this effort will be useful and acceptable to those who are responsible for the production of engineering drawings, bending the metal, and flight testing the result. It is to that audience that this work is dedicated. Based upon the research previously discussed in this report and upon the general philosophy employed, we trust that the various hypotheses and assumptions to be presented in this section will seem plausible and natural. However, philosophy is difficult to convey and the intricate logic underlying the concept proposed in this section is not easily reduced to a convincing narrative. We ask, therefore, that the final test of this effort be the degree to which it is supported by available flight test data.

#### B. THE DATA AND ITS INTERPRETATION

John Arnold's<sup>7</sup> MSE thesis experiment provided the experimental data used by Smith<sup>1</sup> for "calibration" of a pilot rating metric for pitch attitude tracking with a Class IV aircraft in Flight Phase Category A (fixed base simulation). The result is shown in Figure 3. The handling quality metric  $\sigma_{\beta q}$  is hypothesized to represent a measure of pilot effort required for the stabilization of attitude rate  $q$ ; it is a function of pilot dynamics, airframe and FCS dynamics, display dynamics and threshold, and disturbance spectrum.

# Contrails

The estimation or prediction of  $\sigma_{\beta q}$  requires an accurate pilot model that is not tied too closely to any particular data base for its parameterization. In this section we wish to look for physical implications of the metric  $\sigma_{\beta q}$  and to explore the possibility that a simpler criterion for handling qualities can be derived from it that is independent of how one models the human pilot.

The relation between pilot opinion rating  $R$  and the metric  $\sigma_{\beta q}$  of Figure 3 can be approximated on  $1 \leq R \leq 10$  by the empirical formula

$$R = 4.27(\sigma_{\beta q})^{.3} \quad (1)$$

This is an eyeball fit; a more sophisticated fit will be developed in the following paragraphs. However, note from Figure 2 that

$$\sigma_{\beta q} = K_{Dq} \hat{K}_q \sigma_q$$

where

$K_{Dq}$  = equivalent display gain

$\hat{K}_q$  = equivalent pilot gain for control of  $q$

All these gains are those predicted using the optimal pilot model as explained in Reference 1.  $\hat{K}_q$  includes the optimal controller, the Kalman estimator, and the predictor gains. In terms of the pilot perceived  $q$  error,  $q_p$ , we have

$$\sigma_{\beta q} = \hat{K}_q \sigma_{q_p}$$

We could therefore write

$$R = 4.27 \hat{K}_q^{.3} \sigma_{q_p}^{.3} \quad (2)$$

# Contrails

Thus, based on an empirical fit to the Arnold data using the metric  $\sigma_{\beta q}$ , a clear connection exists between rating R and rate error--perceived or actual. This, in itself, is hardly surprising since this was one of the hypotheses of Reference 1. What we have done here is merely to quantify the connection for Arnold's data.

The Reference 1 theory says that pilot rating for attitude control tasks is based upon two factors:

- (1) the level of effort required to control attitude rate, and
- (2) the pilot's perception of the connection between this effort and the adjectives of the Cooper-Harper scale.

It is apparent from the optimal pilot model (Figure 2), and from the formulae above, that the value of  $\sigma_{\beta q}$  attained from a tracking experiment is dependent upon both

- (1) attitude rate error,  $\sigma_q$ , and
- (2) the pilot's q-channel gain,  $\hat{K}_q$

Reference 1 contains an extensive discourse on what Smith terms the "athletic" nature of the rate control problem, as perceived by the pilot. There are three basic thoughts expressed: that attitude is an outer loop quantity with respect to attitude rate; that the piloted control of rate is done more by reflex than by conscious thought; that the pilot's judgment of task difficulty is based almost entirely upon his ability to control rate. Thus, if  $\hat{K}_q$  represents a reflex action, it is plausible that for a homogeneous pilot population it will not be highly variable. Let us investigate this possibility.

Table 1 is extracted from Reference 1 (Table 3, p. 110); it summarizes the q-loop gains,  $\sigma_q$ ,  $\sigma_{\beta q}$ , and pilot rating for Arnold's 14 cases. The pilot model gains were estimated using the optimal control model. The following definitions apply:

TABLE 1. PILOT MODEL PARAMETERS FOR THE ARNOLD DATA (Reference 1)

Case	$K_{Dq}^{\dagger}$	$K_{Fq}$	$K_{q}^{*}$	$\sigma_q$	$\sigma_{\beta q}$	R	$\sigma_{q_p}$	$R_{CAL}$
1	.1128	.638	-3.39	.635	.155	3.50	0.072	2.39
2	.342	.562	-3.47	.996	.664	3.60	0.341	3.81
3	.595	.542	-2.92	2.17	2.04	5.17	1.291	5.68
4	.645	.687	-3.45	2.13	3.26	6.28	1.374	5.79
5	.710	.709	-3.29	2.90	4.80	7.70	2.059	6.53
6	.1246	.532	-1.68	.657	.151	2.82	0.082	2.48
7	.300	.447	-1.68	1.020	.475	3.63	0.306	3.69
8	.590	.409	-1.35	2.11	1.42	4.72	1.245	5.62
9	.1128	.671	-3.63	.445	.122	2.21	0.050	2.14
10	0	.496	-3.61	.156	0	1.61	0	0
11	0	.375	-3.44	.193	0	1.36	0	0
12	.588	.511	-1.55	1.92	1.85	6.00	1.129	5.45
13	.695	.503	-1.42	3.40	3.49	6.33	2.363	6.81
14	.776	.519	-1.33	4.34	4.81	6.50	3.368	7.57

$\dagger$  from Klienman Model

$$\sigma_{q_p} = K_{Dq} \sigma_q$$

$$R_{CAL} = 5.26 (\sigma_{q_p})^{.3}$$

# Contrails

$K_{Dq}$  = equivalent q-channel display gain

$K_{Fq}$  = equivalent q-channel Kalman estimator gain

$K_q^*$  = optimal controller gain, q-channel

$\sigma_q$  = rms  $q(t)$  in degrees/second

These same data are shown in Table 2 for the McDonnell experiment<sup>26</sup>--also extracted from Reference 1 (Table 4, p. 111). It is noted that the gains  $K_{Dq}$  and  $K_{Fq}$ , as used here and in Reference 1, are random input describing functions obtained by computing the ratio of root-mean-square signal levels.

TABLE 2. PILOT MODEL PARAMETERS FOR THE MCDONNELL DATA (Reference 1)

Case	$K_{Dq}$	$K_{Fq}$	$K_q^*$	$\sigma_q^1$	$\sigma_{\beta q}$	$R^2$
1	.944	.836	3.21	.68	1.72	4.8
2	.944	.838	3.21	1.35	3.43	7.2
3	.944	.838	3.21	2.03	5.15	8.0
4	.894	.812	3.26	1.05	2.48	5.5
5	.923	.783	2.50	.47	.85	2.8
6	.923	.783	2.50	.95	1.71	4.1
7	.923	.783	2.50	1.42	2.56	5.1
8	.902	.825	3.54	1.15	3.03	6.1
9	.913	.738	2.80	1.29	2.43	5.3
10	.929	.607	1.15	1.57	1.02	4.6
11	.897	.818	3.19	1.08	2.53	4.5
12	.997	.813	3.11	4.92	12.13	9.0
13	.961	.860	3.42	2.83	8.00	10.0

<sup>1</sup>Model-derived; not recorded in experimental data

<sup>2</sup>Average of experimental values

# Contrails

The gain  $K_{Dq}$  is a measure of the pilot's perception of  $q(t)$ . Arnold purposely introduced a significant display threshold; this is the reason for the small values of  $K_{Dq}$  in some cases (1, 6, 9, 10, and 11). For the McDonnell data, the  $K_{Dq}$  shown represent the equivalent describing function for the pilot's physiological limits of rate perception; McDonnell's display contained no threshold. This is why  $K_{Dq} \cong 1.0$  for all the McDonnell data.

In Table 3, the values  $\hat{K}_q = K_{Fq} K_q^* M_{\delta e} / 14.54$  are shown for both these data sets. The gain  $\hat{K}_q$  is intended to represent the conscious level of piloted control of  $q(t)$ . The factor  $M_{\delta e} / 14.54$  is included to normalize  $\hat{K}_q$  against a standard controlled element gain.<sup>1</sup> It is noted that this normalizing factor was necessary because of the character of the optimal pilot model. It optimizes the loop gain (pilot plus controlled element). Since Arnold's experiments were conducted with two values of controlled element gain, it was necessary to select one value of control effectiveness and reference all the optimal pilot gains to it. If this were not done, then a change in control effectiveness would produce a reciprocal change in  $\hat{K}_q$ ; the nature of the physical problem, however, suggests that this change would not actually occur. The gain normalization was introduced as an attempt to limit the error that might otherwise result from this gain ambiguity. It is remarkable that so little variation in  $\hat{K}_q$  exists for all these data--especially since a broad spectrum of aircraft dynamics is spanned. Also, the Arnold data are averages from five service pilots; McDonnell's data are for one nonservice pilot. The average gain values are

$$(\hat{K}_q)_{\text{avg}} = \begin{cases} 2.01 \sim \text{Arnold} \\ 2.34 \sim \text{McDonnell} \end{cases}$$

The approximate rms fit error to these data, if it is assumed that  $\hat{K}_q$  is constant and equal to the average values above, is



# Contrails

$$\text{rms error} = \begin{cases} 0.63 & \text{Arnold} \\ 0.59 & \text{McDonnell} \end{cases}$$

It is therefore plausible to assume that  $\hat{K}_q$  is not a true parameter of the pilot model but is, in fact, a human constant. If this is true, then the formidable relationship between pilot rating and  $\sigma_{\beta q}$  reduces to the simple formula

$$R = K \sigma_{q_p}^{.3}$$

Note, however, that it is no easy matter to estimate  $\sigma_{q_p} = K_{Dq} \sigma_q$ . The describing function gain  $K_{Dq}$  is dependent on  $\sigma_q$ .

TABLE 3. AVERAGE q-LOOP PILOT GAIN--  
ARNOLD AND McDONNELL DATA

	$\hat{K}_q = K_{Fq} K_{dq}^* M_{\delta_e} / 14.54$	
Case	Arnold	McDonnell
1	2.16	2.69
2	1.95	2.69
3	1.58	2.69
4	2.37	2.65
5	2.33	1.96
6	1.85	1.96
7	1.55	1.96
8	1.14	2.92
9	2.44	2.07
10	1.79	.70
11	2.31	2.61
12	3.78	2.53
13	1.48	2.94
14	1.43	n.a.
Average	2.01	2.34

## Arnold's Data--Average For 5 Pilots

A more detailed examination of the Arnold data is in order from the perspective provided by the result that  $\hat{K}_q$  is approximately constant for these data.

If it is assumed that  $R = 4.27 \hat{K}_q^{.3} \sigma_{qp}^{.3}$  and  $\hat{K}_q = 2.01$ , then  $R = 5.26 \sigma_{qp}^{.3}$ . But  $\sigma_{qp} = K_{Dq} \sigma_q$ . Thus R can be related directly to  $\sigma_q$  by this formula for each case given in Table 1. The result is plotted on Figure 6; this figure is a summary plot of all the data (from Reference 7, p. 63). Note that the value  $\sigma_q$  is an average of all the data for the case indicated. It can be seen that the formula is accurate only for the estimation of average pilot opinion ratings. This has to be true--to the extent that  $\hat{K}_q$  is constant--since the formula is derived from the average rating data of Figure 3.

## Arnold's Data--Interpilot Variability and Observations on the Cooper-Harper Scale

A closer examination of Figure 6 indicates that systematic interpilot differences exist between rating and  $\sigma_q$ . Bluford, for example, consistently gave better ratings for the same  $\sigma_q$  than did Radamacher. A plausible explanation for these differences is that Bluford's interpretation of the task performance vis-a-vis the Cooper-Harper scale was different from Radamacher's.

It follows that a more appropriate and general fit to the rating data of the individual pilots would be obtained by

$$R = K\sigma_q^n \tag{3}$$

The individual pilot ratings and rms error values are given in Tables 4-8; these are extracted from Arnold's thesis. For each pilot, the values K and n were computed to minimize the rms error between the actual ratings and those given by formula 3. The results are summarized in Table 9. The overall rms error of fit (pilot rating) and the average pilot rating for each pilot are also included in the summary. The "grand average" data are the

# Contrails

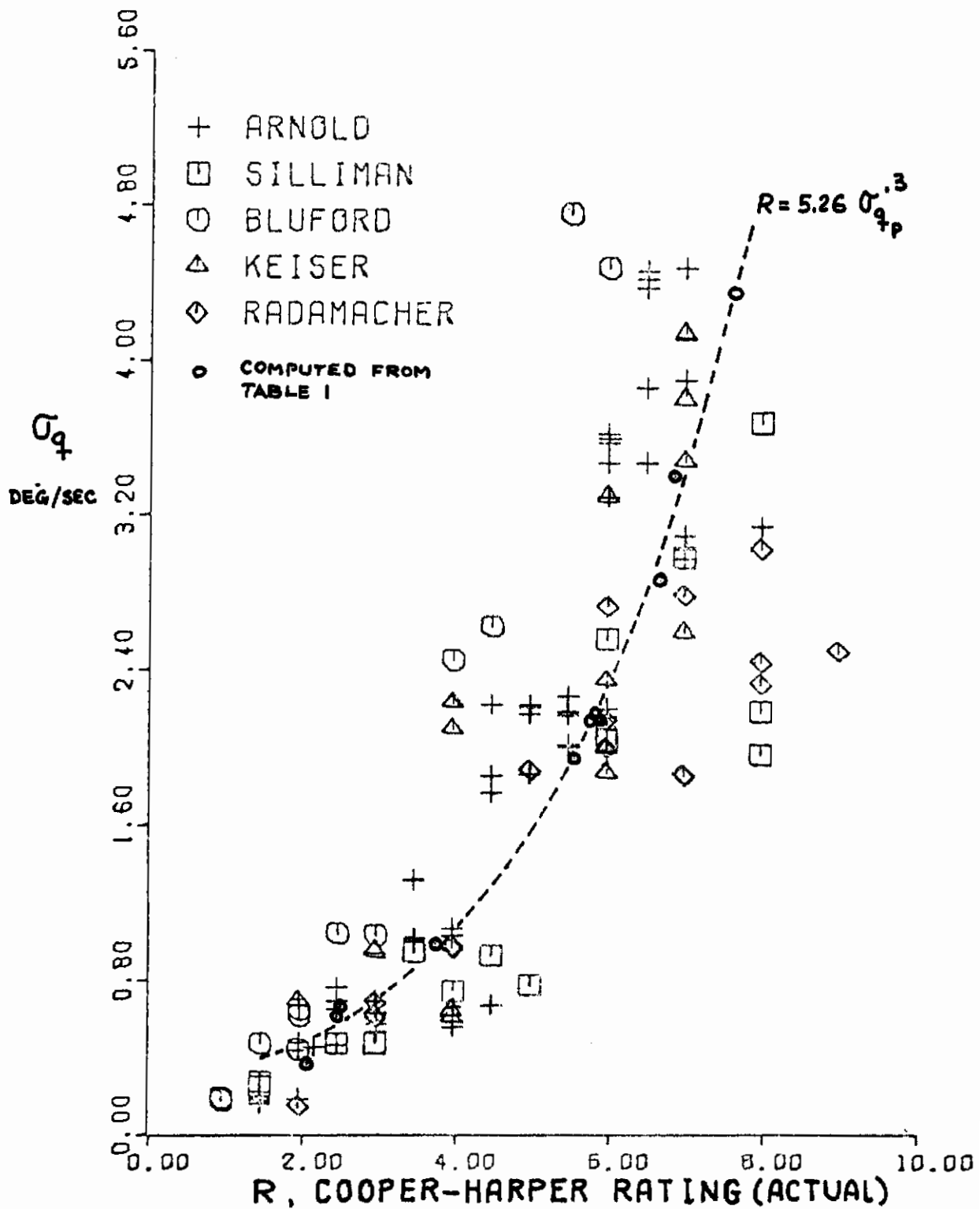

Figure 6. Variation of  $\sigma_q$  With Pilot Rating (Arnold Data)

# Contrails

TABLE 4. PILOT OPINION RATING VS  $\sigma_q$ ;  
SUBJECT: ARNOLD (cont.)

Case	Run	$\sigma_q$	R	
13	1	3.883	7	
	2	3.548	6	
	3	3.268	6	
	4	3.447	6	
	5	3.450	6.5	
	6	3.838	6.5	
	7	3.574	6	
	10	3.600	6	
	14	1	4.397	6.5
		2	4.436	6.5
3		4.352	6.5	
4		4.452	7	

# Contrails

TABLE 4. PILOT OPINION RATING VS  $\sigma_q$ ;  
SUBJECT: ARNOLD

Case	Run	$\sigma_q$	R
1D	3	.634	3
	4	.577	3
	5	.533	3
	6	.559	4
	7	.671	4.5
2D	3	1.035	4
	4	1.015	3.5
	5	1.012	3.5
	6	1.012	3.5
3A	3	1.852	5
	4	1.845	4.5
	5	1.761	4.5
4A	1	2.193	6
	2	2.152	6
	3	2.160	5.5
	4	2.172	5.5
	7	2.254	5.5
5A	3	3.129	8
	4	3.007	7
	5	3.081	7
	8	2.962	7
6C	1	.683	2.5
	2	.679	2.5
	3	.639	2.5
	4	.753	2.5
	7	.680	3.0

Case	Run	$\sigma_q$	R
7C	1	1.057	4
	2	1.306	3.5
	3	.995	3.5
	4	1.014	4
8A	1	2.159	5
	2	2.196	5
	3	2.190	5
	4	2.211	4.5
	5	2.210	5
9	1	.446	2.5
	2	.441	2.5
	3	.422	2.0
	4	.461	2.0
10	1	.162	1.5
	2	.175	1.5
	3	.141	1.5
	4	.168	2.0
	5	.171	2.0
11	1	.172	1.5
	2	.178	1.5
	3	.180	1.5
12	1	2.002	5.5
	2	1.995	5.5
	3	1.963	6
	4	1.980	5.5
	5	1.994	5.5

# Contrails

TABLE 5. PILOT OPINION RATING VS  $\sigma_q$ ;

SUBJECT: KEISER

Case	Run	$\sigma_q$	R
1D	8	.616	4
	9	.608	4
3A	6	2.339	6
	7	2.115	6
6C	8	.681	2
	9	.631	4
7C	7	.934	3
	8	.945	3
8A	6	2.219	4
	7	2.081	4
12	6	2.575	7
	7	1.855	6
	8	1.851	6
13	8	3.277	6
	9	3.457	7
14	5	4.116	7
	6	3.782	7

# Contrails

TABLE 6. PILOT OPINION RATING VS  $\sigma_q$ ;  
SUBJECT: SILLIMAN

Case	Run	$\sigma_q$	R
1D	1	.746	4
	2	.778	5
2D	1	.932	4.5
	2	.945	3.5
3A	1	2.56	6
	2	2.03	6
4A	5	2.17	8
	6	1.95	8
5A	1	3.67	8
	2	2.97	7
9	5	.457	2.5
	6	.456	3
11	4	.233	1.5
	5	.254	1.5

# Contrails

TABLE 7. PILOT OPINION RATING VS  $\sigma_q$ ;  
SUBJECT: RADAMACHER

Case	Run	$\sigma_q$	R
2D	9	.962	4
	10	.975	4
4A	8	1.981	6
	9	2.135	6
5A	6	3.011	8
	7	2.420	8
	9	2.313	8
	10	2.481	9
6C	5	.607	3
	6	.596	3
	10	.673	3
	11	.610	3
7C	5	.964	4
	6	.964	4
8A	8	1.860	5
	9	1.861	5
10	6	.127	2
	7	.129	2
12	9	1.837	7
	10	1.831	7
13	11	2.760	7
	12	2.700	6



# Contrails

TABLE 8. PILOT OPINION RATING VS  $\sigma_q$ ;  
SUBJECT: BLUFORD

Case	Run	$\sigma_q$	R
1D	10	.619	2
	11	.645	2
2D	7	1.033	3
	8	1.036	2.5
3A	8	2.614	4.5
	9	2.441	4.0
9	7	.454	1.5
	8	.426	2
10	8	.163	1
	9	.164	1
11	6	.158	1
	7	.176	1
14	7	4.735	5.5
	8	4.455	6

# Contrails

TABLE 9. SUMMARY OF PILOT RATING FORMULA PARAMETERS  
LEAST-SQUARED FIT TO ARNOLD'S DATA

$R = K\sigma_q^n$				
Subject	$K^3$	n	$\sigma_\epsilon^1$	$\overline{POR}^2$
Bluford	2.606	.527	.218	2.6
Arnold	3.559	.450	.588	4.4
Keiser	3.844	.431	.906	5.1
Silliman	4.202	.605	.983	4.9
Radamacher	4.391	.474	.982	5.2
$R = 3.83 \sqrt{\sigma_q}$ $\overline{POR} = 5.236 \sqrt{\sigma_\epsilon}$				

- 1  $\sigma_\epsilon$  = RMS (POR -R)
- 2  $\overline{POR}$  = Arithmetic Average (each subject)
- 3 K = Cooper-Harper Gain
- 4  $\frac{(\sigma_{POR})_{6.5}}{(\sigma_{POR})_{3.5}} \approx 4$

least-squared fit values for the generalized equation to all the rating data; it is included as a measure of the accuracy of the original approximation to the relation  $POR (\sigma_{\beta q})$  of Figure 3.

These results indicate that the Arnold data are more consistent on an individual pilot basis than on an average basis across all five pilots. The interpilot differences are systematic and could be interpreted to result from how each pilot interprets the task performance/control effort versus the Cooper-Harper scale.

# Contrails

It is also interesting that the error of fit between the formula  $R = K\sigma_q^n$  and the actual pilot opinion rating seems to be strongly correlated with the average rating for each pilot. This can be seen from Table 9. Bluford, for example, primarily saw aircraft dynamics that he rated as very good (average POR = 2.6), and the rms error of fit for his data is minimum (0.218 units of the Cooper-Harper scale). Rademacher's data indicates a much poorer rms fit by the formula; the aircraft dynamics were, on average, rated much worse by him than those flown by Bluford.

The connection between  $(POR)_{avg}$  and rms error of fit  $\sigma_E$  can be summarized by the equation

$$(POR)_{avg} = 5.236 \sigma_E^{.445} \quad (4)$$

It is assumed that the exponent should actually be 0.5. This is shown in Table 9 and in Figure 7.

The two constants minimize the mean-squared error between actual, averaged pilot opinion rating and that given by formula. The rms error of fit of this equation to the data of Table 8 is 0.184 Cooper-Harper units. These data are shown in Figure 7. This relation is construed to represent the expected variation of actual pilot opinion rating from the true nominal rating. The "expected nominal" rating is given by  $(POR)_{avg}$ . Figure 7 is labeled to indicate this interpretation of these results.

If this interpretation is correct, then Equation 4 indicates that increasing task difficulty will result in increased variability in Cooper-Harper ratings. By direct calculation the variance at the Level 1 and 2 boundaries is:

$(POR)_{avg}$	$\sigma_E$
3.5	.404
6.5	1.626

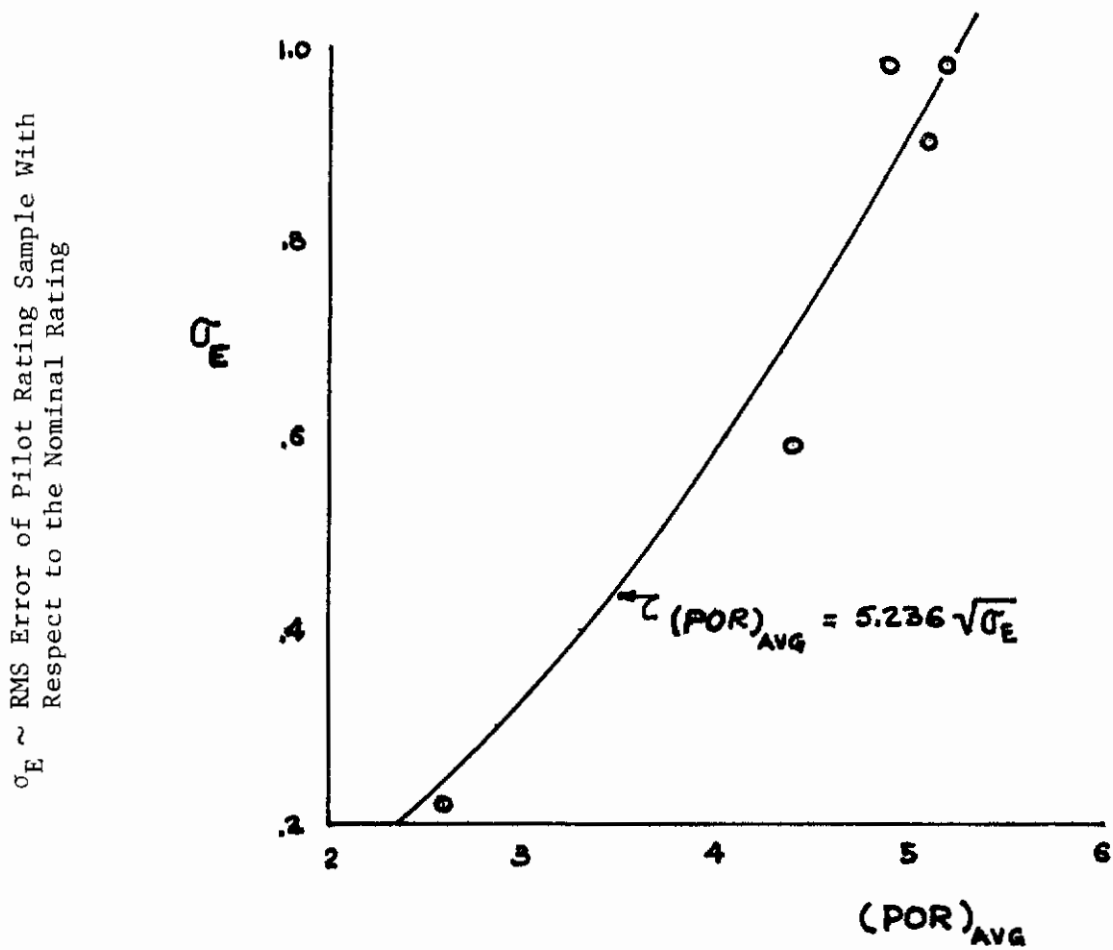

Figure 7. Cooper-Harper Rating Error Variation as a Function of Average Pilot Opinion Rating

# Contrails

We should expect, therefore, that the variance of Cooper-Harper rating will be about four times greater at the Level 2 boundary than at the Level 1 boundary.

Equation 4 constitutes a quantification of the hypothesis of Reference 1 that  $\sigma_{\beta q}$  --and therefore pilot rating--will be more variable as the degree of task difficulty is increased. Equation 4 could be used to estimate the number of data runs that would be required for the estimation of average pilot rating at a prescribed level of statistical validity for several pilot subjects.

These results seem to indicate that significant interpilot differences exist within the Arnold data base. For the general problem of understanding and predicting pilot opinion rating, however, it is necessary that interpilot averages be used. Nevertheless, with the benefit of the preceding analyses we can be comforted by the thought that our knowledge of the nature and extent of pilot variability is perhaps improved.

The average value of the exponent in equation 3, across all five pilots, equally weighted, can be computed from Table 9:

$$(n)_{\text{avg}} = 0.497$$

In deference to Weber's Square Law, it will be assumed that these data indicate that, in general,

$$n \cong 0.5$$

for all pilots. This will be assumed. Thus, the general formula for pilot rating becomes

$$R = K\sqrt{\sigma_q} \tag{5}$$

# Contrails

where K may be a constant but different value for each pilot. Its value depends upon two factors:

- how the individual interprets the specific task requirements, and
- his interpretation of how this relates to the adjectives of the Cooper-Harper scale.

The average "rating gain" K across all five pilots for the Arnold experiment is obtained from Table 9 to be

$$K_{\text{avg}} = 3.83$$

It can therefore be concluded that a general rating model for Arnold's experimental data is

$$R = 3.83 \sqrt{\sigma_q} \quad (6)$$

This model is not intended (or suited) for handling qualities prediction. It was derived here to emphasize those features of aircraft response that are most significant to the handling qualities problem. This model approximates the case of single axis, pitch attitude control of Class IV aircraft in Flight Phase Categories A and C where kinesthetic cues are of no significance.

Since the Cooper-Harper Scale is bounded by 1, it might seem that a better formula would have the form

$$R = 1 + K \sigma_q^n \quad (7)$$

If the above calculations are repeated to estimate K and n to fit Arnold's data with minimum mean-squared error, the following results are obtained:

# Contrails

Subject	K	n	rms error (Cooper-Harper)
Bluford	1.179	1.178	.965
Arnold	2.397	.719	1.198
Keiser	2.754	.572	1.432
Silliman	2.886	.916	1.573
Radamacher	3.329	.656	1.361

These results are less systematic with much worse fit errors than those obtained above for Equation (3).

This result seems to indicate a contradiction. Equation 6 shows R approaching zero as  $\sigma_q$  approaches zero. The resolution of this apparent contradiction can be used to partially confirm the validity of these results, as follows.

Consider that for  $R = 1$ , from Equation (6)

$$\sqrt{\sigma_{q_0}} = 1/3.83$$

$$\sigma_{q_0} = .068 \text{ degrees/second} \cong 1 \text{ milliradian/second}$$

This value is assumed to equal the approximate threshold for visual perception of rate. There is, therefore, no conflict between formulas (3) and (6) and the Cooper-Harper scale.

We also note that these formulae are bounded by  $R \leq 10$  according to the definitions of the Cooper-Harper scale. The use of other adjectives or scale descriptions would change the constants in equation (3); the physical principles on which this theory rests would not be changed.

Equation (6) could be rederived in terms of perceived rate,

$$R = K\sigma_{qp}^n = K(K_{Dq} \sigma_q)^n \quad (8)$$

# Contrails

The equivalent display gain  $K_{Dq}$  for all of Arnold's data can be estimated using the optimal pilot model; this was done in Reference 1 only for data averaged across all subjects for each set of aircraft dynamics. Using the values  $K_{Dq}$  from Table 1 as though they are constant for all pilots (a reasonable assumption since  $K_{Dq}$  is mainly a display function), then the following results are obtained; the values  $K$  and  $n$  are those that minimize the mean-squared error in estimation of pilot rating with (8):

Subject	K	n	rms error
Bluford	3.889	.269	.280
Arnold	5.074	.239	.615
Radmacher	5.987	.287	.802
Silliman	6.215	.233	.886
Keiser	5.206	.202	.932
Average	5.274	.246	--

Then on an averaged basis

$$R = 5.27 \sigma_{q_p}^{.246}$$

or, again in deference to Weber,

$$R = 5.27 \sqrt[4]{\sigma_{q_p}} \tag{9}$$

Equation (9) can be used to provide a consistency check on all these results, as follows:

$$R = 5.27 \sqrt[4]{\sigma_{q_p}} = 5.27 \sqrt[4]{K_{Dq}} \sqrt[4]{\sigma_q}$$

But from (6)

$$R = 3.83 \sqrt{\sigma_q}$$



Solve for  $K_{Dq}$  ;

$$\frac{5.27}{3.83} \frac{\frac{4}{\sqrt{K_{Dq}}}}{\frac{4}{\sqrt{\sigma_q}}} = 1$$
$$\frac{4}{\sqrt{K_{Dq}}} = .726 \frac{4}{\sqrt{\sigma_q}}$$

$$K_{Dq} = .278 \sigma_q$$

By direct calculation the average  $\sigma_q$  from all 115 runs is  $\sigma_q = 1.896$  °/s.

For this value, obtain  $K_{Dq} = .527$ . From Graham and McRuer,<sup>27</sup> p. 238 for the gaussian input describing function for a simple threshold, this value for  $K_{Dq}$  would imply that

$$\frac{a}{\sigma_q \sqrt{2}} = .44$$

or

$$a = 1.18 \text{ °/s}$$

This value for equivalent threshold compares favorably with the direct estimate by Dillow and Picha<sup>28</sup> of  $a = 1.08$  °/s for the Arnold experiment. On this basis, the results embodied in (6) and (9) appear to be consistent with the factual data base.

## C. TASK EFFECTS ON PILOT OPINION RATING AND COMMENTS ON RATING VARIABILITY

### Task Effects

The results of the above paragraphs were derived from simulator data for the precision control of pitch attitude in turbulence. The dynamics simulated

# Contrails

were those representative of Class IV aircraft. The general consistency between Arnold's simulation results and those of Neal and Smith for actual flight test was established by Arnold and further refined in Reference 1.

One of the major difficulties presented by the spectrum of potential advanced FCS candidates is that the piloting tasks may differ significantly from those for which handling qualities data now exists. We wish to extend the results obtained here in such a manner that they can be usefully applied to a variety of tasks other than merely pitch control.

The theory of Reference 1 is restricted only by

- lack of a suitable pilot model for multiple loop/axis prediction of pilot opinion rating, and
- lack of involvement of motion cue effects on handling qualities.
- lack of a model for control feel effects on pilot opinion ratings.

We can do nothing here about the first restriction; the second will be treated in later paragraphs of this report. Until a broader data base can be compiled, there is no reason why the variable  $\sigma_q$  cannot be replaced with  $\sigma_{\dot{x}}$ , where  $x(t)$  represents some system response variable; the only restriction is that  $x(t)$  must be displayed to the pilot in some manner, and task-related so that it is controlled by him in an approximately single-axis fashion.

The usual case of interest for future FCS would probably have a cue  $x(t)$  displayed on a HUD; this symbol might implicitly contain flight path, altitude, or fire control information. A representative concept for HUD symbology of this sort is depicted schematically in Figure 8. This particular design has been proposed by Bateman.<sup>28</sup> The interesting feature of this concept to HUD design for the integration of guidance, flight path control, and fire control is that the symbology and the pilot's task remains essentially constant throughout the envelope of flight; i.e., put A on B to accomplish Task C. Properly done, an approach of this sort to display design might simplify the handling qualities problem. The point is that the above method for handling qualities prediction in single axis tracking is applicable to such systems.

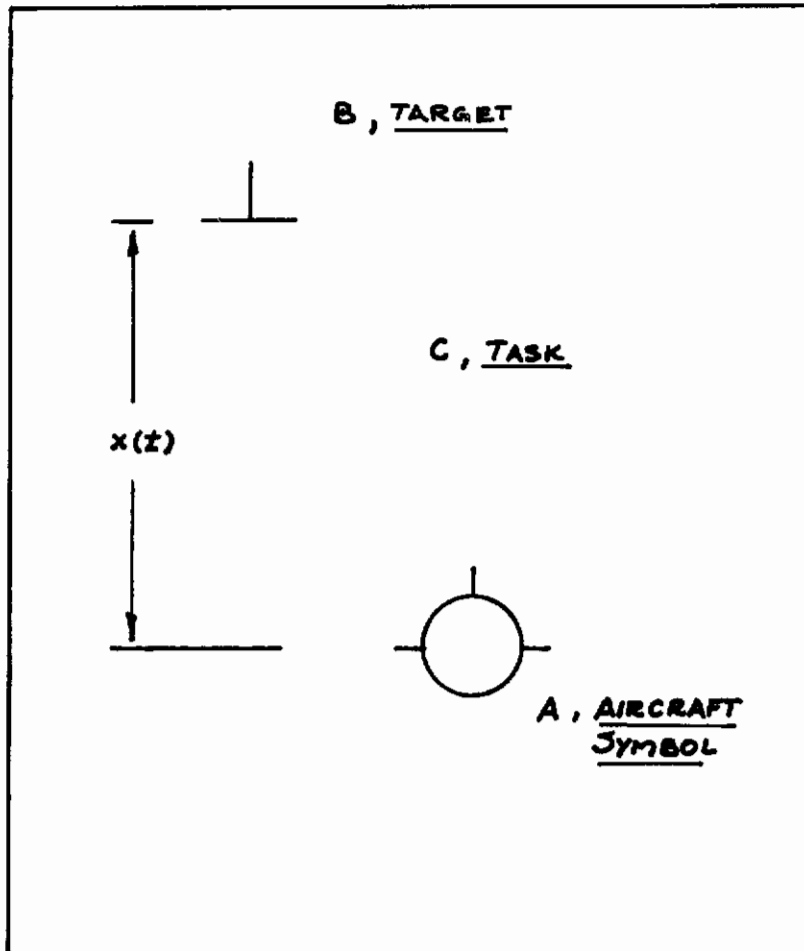

Figure 8. The ABC HUD Concept

# Contrails

A complex task such as VFR control of flight path cannot be directly analyzed with the methods discussed in the last paragraph. Such tasks are inherently multiple loop if one assumes as is always done that the pilot uses pitch attitude as an inner loop cue with a flight path or angle cue as the outer loop variable. An alternate approach, consistent with the switching model proposed for pilot dynamics, is to assume that all piloting cues are controlled in single axis fashion, but that the control of more than one cue requires the pilot to time-share his attention among the various single loops.

It can therefore be postulated that the effect of task definition is to

- (1) define the cues required for task performance, and
- (2) establish the limits on acceptable system dynamic performance.

The closed-loop pilot-vehicle system structure can, for present purposes, be visualized as an amalgam of single-axis control systems coupled only through a "switch." The switch, however, is a logical process of decision making performed by the pilot. We suspect that this concept is a reasonably accurate portrayal of the pilot's adaptation. This philosophy was discussed at length in Reference 1. It is dynamically equivalent to the dual axis switching model of Onstott.<sup>10, 29</sup> The point of departure, however, is significant.

The implication of the Reference 1 theory, which we postulate here to be valid, is that one need not consider more than one control axis at a time to establish basic handling qualities or handling quality requirements. Our interest is to devise methods for the transfer of pilot-vehicle analysis techniques to the development of handling quality specifications.

It was previously noted that one of the difficulties presented by advanced FCS concepts is that we can't be certain what specific piloting tasks will be--even functionally in some cases. It is reasonably safe to assume that most future systems must perform certain baseline tasks. The most notable of these for handling quality investigation are

# Contrails

- Power approach
- Landing flare
- In-flight refueling
- Formation flight
- Attitude hold in turbulence
- Air-to-air weapons delivery
- Air-to-ground weapons delivery

## Pilot Rating Variability

The analysis above of Arnold's experimental results, if anything, strongly disputes the notion that pilot "subjective" evaluations (and the Cooper-Harper scale, in particular) are too variable and baseless to be of value in systems analysis. In some cases, the intrapilot data are accurate to three decimal places when the correlation is made of  $\sigma_q$  and Cooper-Harper rating. It is long past the time when we, as a community, must mature to the point where we can accept the idea without being self-conscious that pilot evaluations are the only measures of handling qualities that have meaning. The results above go even further. They indicate that pilot ratings are remarkably consistent when properly interpreted.

It is hoped that the comments made about the dependency between the expected value of pilot opinion rating and the rating variance will be further tested by simulation and flight test. Reference 1 hypothesized that such a relationship exists and that it exists for good physical reasons. The fact is that Cooper-Harper ratings vary because they reflect a physical phenomenon; the point here is that the variance is systematic. The results above indicate that this will be a practical consideration only for the determination of Level 2 boundaries for handling qualities.

Systematic differences between pilots exist. Again, this is no reason to doubt the utility of the Cooper-Harper scale. This effect must be considered when developing a data base or preparing a handling quality specification. The best available and practical solution to this problem at the present time is to use at least two pilot subjects and look for systematic

rating differences. The widely referenced Neal-Smith data<sup>6</sup> are notable for their remarkable interpilot consistency. This may not appear to be the case if one merely looks at these data; we conclude that it is so after considerable analysis, the results of which will be presented later in this report.

## D. THE NO-TRACKING HYPOTHESIS

It was established in Paragraph B that Cooper-Harper rating is proportional to the square root of rms rate error:

$$R = 3.83 \sqrt{\sigma_q} \quad (6)$$

This result applies for the single axis regulation of pitch attitude with turbulence input in the absence of inertial acceleration cues.

It follows from (6) that the optimization of handling qualities requires that  $\sigma_q$  approach the value corresponding to the perception threshold; i.e., no tracking is performed, and the Cooper-Harper rating is 1. This appears to explain Arnold's Cases 10 and 11.

---

### The No-Tracking Hypothesis

Optimum handling qualities demands minimum closed-loop control by the pilot.

---

### Flight Test Implications

One very attractive feature of this concept is that it permits the transition between handling qualities data obtained for tracking and that obtained from the usual flight test which requires gross maneuvering. Time available for task performance is not a factor in the assessment of handling qualities if the problem can be reduced to its open-loop, constituent components.

# Contrails

## Application to Specification Development

If the features of open-loop aircraft response to control can be identified which promote pilot tracking, then these imply degraded handling qualities. The quantification of such response properties against available data will then lead in a natural manner to the development of handling quality specifications. This is the procedure that will be implemented in the remainder of this report.

### An Historical Perspective

The result expressed by (6), viz.,  $R = 3.83 \sqrt{\sigma_q}$ , has ramifications that may be discomfoting to some. It implies that pilots do not wish to exert closed loop control, and that the more required because of either aircraft-FCS dynamics, turbulence intensity, or flight director prompting, the more degraded the handling qualities. Here, we assume that a pilot tracks  $q$  because of task requirements that (explicitly or implicitly) place limits on tolerable  $\theta$ .

Why, then, have we spent all these years (three decades, approximately) in pursuit of better models of pilot dynamics for closed loop tracking? It seems that the answer is . . . because it seemed like a reasonable thing to do at the time. And it was.

What we have lacked from the study of pilot-vehicle system dynamics was a concept for how system dynamics could be translated into handling quality assessments at the analytical level. Reference 1 was dedicated to bridging that technology gap. The work on these pages merely represents an attempt to translate that philosophy and theory into engineering design practice.

In fact, the "no tracking" hypothesis, above, seems to have taken us full-circle: we have employed the art of pilot-vehicle analysis to the limits of our ability and concluded that optimum handling qualities requires minimum or no pilot contribution to system dynamics. For the development of handling quality specifications, this is an enormous simplification. It

# Contrails

remains to be seen whether nonoptimum handling qualities can be quantified using those same parameters which identify optimum handling.

The correct interpretation of these results is, we believe, that a pilot does not wish to perform unnecessary tracking within the context of mission performance. The accomplishment of gross maneuvers (as in air combat) requires that the pilot initiate a change in aircraft state and then stabilize on a new one; this necessarily entails a certain level of closed loop control at each end of the problem. What he does not want is to be made (by dynamics or turbulence) to perform delicate state regulation before, during, or after the basic maneuver is performed. The factors which degrade the handling qualities sufficiently to cause this will also influence the pilot-vehicle system dynamics in a tracking task; they cannot necessarily, however, be entirely identified from tracking experiments with gaussian inputs. This may serve for the identification of adverse vehicle properties that are directly related to frequency domain parameters which govern the dynamics of closed loop tracking (e.g., phase margin, resonance, crossover frequency, etc.). Those aircraft response properties that are best expressed in the time domain may not clearly appear from forced tracking experiments. The frequency domain effects are the only part of this problem that has been addressed with state-of-the-art pilot vehicle systems analysis methodology.

What we conclude, therefore, is that the classic work remains valid and useful. We have altered the context for its applications to problems of handling qualities. We have taken the further step of suggesting that a hybrid approach--incorporating aspects of both frequency and time domain modeling--is the natural evolution of the handling qualities theory of Reference 1. This direction will, we trust, properly account for the attractive features of both approaches. Most importantly, the results of this will be based upon a physical model for handling qualities which should strip away many of the ambiguities and ad hoc qualities of the subject which have prevented its realistic incorporation into aircraft design practice.



## E. LESSONS FROM PILOT-VEHICLE SYSTEMS ANALYSES

### Stereotypes for Aircraft Dynamics

Among McRuer's many contributions to the art of pilot-vehicle systems analysis, perhaps the most important was the concept of using simple stereotypes for the general classification of aircraft-FCS dynamics. These were used in the experiments of Reference 3 as a means for simplifying the experimental design and for extending the range of data applicability.

These stereotypes are:

$$Y_c(s) = K_c/s, K_c, K_c/s^2; K_c/s-\lambda \text{ and } K_c/s(s-\lambda)$$

The corresponding handling qualities for these range, in the order presented, from optimum to barely controllable.

Reference 1 offers an explanation for this ranking according to the level of error rate control activity (workload, if you must) required of the pilot for acceptable tracking performance. This was used, in part, as a heuristic defense of the multiple loop pilot model for single axis tracking.<sup>1,9</sup> The success of this result led directly to the identification of  $\sigma_{\beta q}$  as the central handling qualities parameter for pitch attitude control. In essence, this correlation should be regarded as a rationalization of the connection between the controlled element stereotype and the equalization required of the pilot. [Note that the manner in which pilot control of rate error appears as a lag in the servo description of the human pilot is explained in References 1 and 9.] However, this work did not yield a rational assessment of the importance of controlled element dynamic gain--the amplitude ratio vs frequency behavior on a Bode plot.

# Contrails

## Closed Loop Structural Stability, Mode Switching and Pilot Technique

The servomechanisms theory for human pilot dynamics and the experiments performed in establishing the general validity of the theory led to a fundamental tenet of analytical handling qualities: handling qualities are optimum for aircraft dynamics of the form  $K_c/s$ .

The theory of Reference 1 suggests that the optimality of  $K_c/s$  is due in part to its minimum requirement for piloted control of rate (roughly but not exactly the same as lead equalization). The rate control required for task performance is a direct function of the controlled element phase properties (e.g., as on a Bode diagram). However, one of the rules for estimation of pilot equalization requirements from the servo theory is that these be selected to create a sizable region in the frequency domain where the slope of the open loop system amplitude ratio (pilot plus aircraft) is approximately -20 db/decade. The open loop gain is then selected so that the 0 db line passes through the midpoint, roughly, of that region. However well this rule might have been shown to work in past applications, it is nonetheless empirical.

The general question of the relative importance to handling qualities of the gain and phase properties of aircraft dynamics has never been properly assessed. The servo theory, as indicated above, uses these interchangeably-- which may be satisfactory for closed loop control with all-linear system dynamics, and for which higher order system dynamics do not exist which significantly affect the system phase near crossover. It is plausible that the amplitude and phase properties of aircraft dynamics can have important, distinct contributions to handling qualities.

A curious item noted in connection with the study of  $PIO^2$  was that for aircraft known to have  $PIO$  tendencies the most appropriate pilot model for the explanation of available results should be derived based only on the amplitude ratio vs frequency properties of  $\frac{\theta}{F_s}(j\omega)$ . That is,  $PIO$  tendencies appear to be more strongly reflected by magnitude than by phase

# Conclusions

properties. The importance of this observation cannot be overemphasized. Once it is known which of the elementary controlled element stereotypes most closely approximates the aircraft dynamics of interest, then a realistic assessment of pilot-vehicle system bandwidth can be made. This can be done based upon the fixed-base simulator data of Reference 3 which was distilled to yield system crossover frequency as a function of controlled element form. Some of these data are shown in Figure 9 of this report. This frequency can then be used to estimate PIO potential, as was indicated in Reference 2, by examining normal acceleration phase lag at that frequency. It was determined that for the available case history data on PIO the selection of the appropriate controlled element stereotype (i.e.,  $K_c$ ,  $\frac{K_c}{s}$ ,  $\frac{K_c}{s^2}$ , etc.) is best made by considering only the character of  $\left| \frac{\theta}{F_s} \right|$  in the region of probable crossover frequency. The phase properties  $\angle \frac{\theta}{F_s}(j\omega)$  are very important in defining closed loop system stability and therefore pilot equalization requirements. This, however, would be equally true in flight or in a fixed-base simulator; it tells us nothing, really, about aircraft behavior in the presence of motion cues--i.e., in actual flight. The phase angle behavior of  $\frac{\theta}{F_s}(j\omega)$  does have the important property of establishing the basic pilot-vehicle system closed loop dynamics when acceleration is not a pilot cue. We are therefore led to suspect that the amplitude response properties of pitch attitude are somehow related to the mechanisms by which kinesthetic cues can influence pilot-vehicle system dynamics and handling qualities.

It was also noted that when  $\frac{\theta}{F_s}(s) \cong K_c$  PIO is a potentially severe problem<sup>2, 25</sup> [PIO does not require this, however<sup>2</sup>]. For dynamics of this form, stability of the closed loop  $\theta \rightarrow F_s$  would hardly seem to be a problem. The fact that it is, in actual flight, suggests that the system stability is somehow reduced because of motion cue effects. A major problem for analysis is that we can't be certain just what constitutes the system dynamics since we don't know what cues are really used by the pilot in actual flight--we can only speculate and then test the speculation.

# Contrails

The PIO theory<sup>2</sup> was developed by precisely that approach; its recent confirmation against developmental experiences (F/TF-15<sup>30</sup> and Shuttle) indicates the essential validity of the assumptions on which it is based. The most prominent of these are:

- (1) that normal acceleration  $a_{z_p}$  is the only significant motion cue,
- (2) that the bandwidth of the single axis, piloted control of  $a_{z_p}(t)$  is determined by the bandwidth of the single axis, piloted control of  $\theta(t)$ , and
- (3) that  $a_{z_p}(t)$  will probably not be controlled in single axis fashion unless this is catalyzed by a sufficiently resonant  $\theta(t)$  response-- which may be due to open or closed loop dynamics.

With a pure gain controlled element abrupt changes in pilot equalization (rate feedback) can create large, abrupt changes in closed loop dynamics.

The mechanism by which this can occur is explained in References 1 and 9 and is repeated here. Using the pilot-vehicle system model of Figure 2 (page 46), and introducing  $K_q$  and  $K_\theta$  as shorthand representations for the equivalent forward path gains in the pilot model, the servo model for the human pilot<sup>3</sup> can be expressed in terms of multiple loop model parameters:

$$Y_p(s) = \frac{K_\theta}{1 + sK_q Y_c(s)}$$

All higher order pilot dynamics associated with time delays and the neuromuscular system are neglected to illustrate the point.

The servo model  $Y_p$  is therefore seen to include controlled element dynamics. [It should be kept in mind that direct measurements of  $Y_p$  can be made; this has not yet been done for the multiple loop pilot model parameters.] When the controlled element is a pure gain, i.e.,

$$Y_c(s) = K_c$$

then

$$Y_p(s) = \frac{K_\theta}{K_q K_c s + 1}$$

Thus, pilot control of rate creates what appears to be a low frequency lag in the pilot dynamics when these are interpreted against the classic servo model (which requires a single input and a single output). This result applies only when  $Y_c(s) = K_c$  is a good approximation. The dependency of crossover frequency on  $K_q$  can now be determined:

$$\left| K_c Y_p(j\omega_c) \right| = 1$$

$$\frac{K_\theta K_c}{\sqrt{1 + (K_q K_c \omega_c)^2}} = 1$$

$$(K_q K_c \omega_c)^2 + 1 = (K_\theta K_c)^2$$

$$\omega_c = \frac{\sqrt{(K_\theta K_c)^2 - 1}}{K_q K_c}$$

$$\frac{\partial \omega_c}{\partial K_q} = -\frac{1}{K_q^2 K_c} \sqrt{(K_\theta K_c)^2 - 1}$$

For constant  $K_\theta$  and  $K_c$ , the change in  $\omega_c$  following a change in  $K_q$  is

$$\Delta \omega_c = \left( \frac{\Delta \omega_c}{\Delta K_q} \right)_0 \Delta K_q = \omega_c - \omega_{c0}$$

$$\omega_{c0} = \omega_c \text{ for } K_q = K_{q0} \text{ (nominal value)}$$

# Contrails

$$\Delta K_q = K_q - K_{q0}$$

$$\Delta \omega_c = -\omega_{c0} \left( \frac{\Delta K_q}{K_{q0}} \right)$$

$$\omega_c = \omega_{c0} \left( 1 - \frac{\Delta K_q}{K_{q0}} \right)$$

Halving  $K_q$  (i.e.,  $\Delta K_q = \frac{1}{2} K_{q0}$ ) increases  $\omega_c$  by 50 percent; if  $K_q \rightarrow 0$ ,

$\Delta K_q = -K_{q0}$  and  $\omega_c \rightarrow 2\omega_{c0}$ . This last example might correspond to the case where task demands are so great that the pilot's attention is diverted away from control of rate; this was the case postulated by the PIO theory of Reference 2. A large, abrupt increase in  $\omega_c$  of this sort would generally result in pilot resonance: possible even short term, pitch loop instability.

It was further suggested in Reference 1 that a high-fidelity model for pilot dynamics might include a switching function at the point where commands from the higher centers (cerebellum, thalamus, etc.) are transmitted to the neuromuscular system for action. This would permit switching to occur between all feedback cues to these higher centers (visual position, visual rate, kinesthetic) according to some logic which we do not yet grasp. This intuitive concept was implemented during the development of the PIO theory of Reference 2 and led directly to the conclusion that, for brief periods during which a pilot concentrates only upon a single feedback quantity, the corresponding pilot model is approximately  $K_x e^{-\tau_x s}$  where  $K_x$  is the gain of the x-channel (the one being controlled) and  $\tau_x$  is the corresponding channel time delay. This model was incorporated directly into the acceleration loop stability criterion of Reference 2 that establishes the necessary condition for PIO to occur.

When the possibility of mode switching of this sort is admitted, then it becomes apparent that the pure gain controlled element may produce very

# Contrails

different closed loop properties than would be expected for the remaining controlled element stereotypes. The switching mechanism suggests that the pilot-vehicle system dynamics will be nonstationary with measured crossover frequency variations of approximately two-to-one. This is partially confirmed by the crossover frequency data of Reference 3, some of which are shown in Figure 10, Page 109. It must be borne in mind that these data were obtained from a single axis, visual tracking experiment. It is interesting that  $\omega_c$  becomes more variable as  $Y_c(s)$  becomes more nearly equal to the pure gain stereotype. Once again, it is noted that the slope of

$$\left| \frac{\theta}{F_s} \right|$$

appears to adequately parameterize this behavior.

Flight tests of aircraft for which  $\frac{\theta}{F_s} \cong K_c$  would be expected to demonstrate "abrupt" response to control; the pilot might comment that the required control is "touchy" or "overly sensitive." Occasional resonances in pitch would be expected to occur at frequencies of about twice the expected pilot-vehicle system bandwidth. While these might not appreciably degrade handling qualities in a fixed-base simulation, these resonances might, in flight, couple with  $a_{z_p}$  to produce a serious control problem.

Consider the case where  $\frac{\theta}{F_s}(s) \cong K_c/s^2$ . The handling qualities with such dynamics are known to be poor. Stability is a problem which is solved only by the generation of considerable pilot lead. PIO should not be so worrisome a problem with these dynamics (although it can be if the  $\theta$  and  $a_{z_p}$  dynamics are mismatched). In fact, one recommendation<sup>2</sup> for eliminating PIO tendencies of the YF-12 in aerial refueling was to turn off the pitch damper in order to force the dynamics to resemble  $K_c/s^2$ .

In contrast with pure-gain dynamics, the closed loop, pilot-aircraft system dynamics with  $\frac{\theta}{F_s}(s) \cong K_c/s^2$  are insensitive to pilot equalization and gain. Once again, this result follows directly from the slope of the

# Conclusions

controlled element amplitude ratio. It is noted that  $K_c$  and  $K_c/s^2$  represent practical extremes for typical pitch attitude dynamics.

We are led to suspect that the slope of  $\left| \frac{\theta}{F_s}(j\omega) \right|$  in the region of crossover frequency for pitch tracking, i.e.,

$$\frac{d}{d\omega} \left| \frac{\theta}{F_s}(j\omega_c) \right|$$

will parameterize the sensitivity of closed loop control to pilot technique. This conclusion is not due to the slope effect on pitch controllability, per se. It is because of the manner by which the closed loop control of pitch can influence the pilot's use of normal acceleration as a dominant cue.<sup>2</sup>

The distinct effects due to  $\frac{\theta}{F_s}$  and  $\frac{d}{d\omega} \left| \frac{\theta}{F_s} \right|$  that are hypothesized to exist can be summarized for the three stereotype pitch attitude dynamics, as follows:

$$\frac{\theta}{F_s}(s) \cong K_c :$$

- (a) Fixed base simulation: no motion cue exists. The pilot equalizes the response by, effectively, creating substantial low frequency lag. Closed loop dynamics are sensitive to pilot-adapted lag and gain when

$$\frac{d}{d\omega} \left| \frac{\theta}{F_s} \right| = 0$$

The handling qualities may be satisfactory, depending on input amplitude and bandwidth, since controlled element phase lag

$$\frac{\theta}{F_s} = 0$$

at all frequencies.



# Contrails

(b) Actual flight: the slope

$$\left. \frac{d}{d\omega} \left| \frac{\theta}{F_s} \right| \right| = 0$$

can lead to sudden, large increases in closed loop frequency and consequent resonance due to variations in pilot gain and lag. If the pilot attempts to track  $a_{z_p}^a(t)$  resonances resulting from  $\theta$  control, system stability can be degraded, depending on

$$\times \frac{a_{z_p}^a}{F_s}$$

at the frequency of  $\theta$  loop resonance.<sup>2</sup>

$$\frac{\theta}{F_s} (s) \sim \frac{K_c}{s}$$

In either fixed base simulation or actual flight, stability of the pitch closed loop is not a problem since

$$\times \frac{\theta}{F_s} = -90^\circ$$

is not enough to destabilize the closed loop. The slope

$$\left. \frac{d}{d\omega} \left| \frac{\theta}{F_s} \right| \right| = -20 \text{ db/decade}$$

is sufficient to ensure that neither changes in pilot gain nor equalization will have a sensitive effect on closed loop dynamics. Besides, the equalization required is minimal. Closed loop pitch resonances are unlikely; therefore,

$a_{z_p}^a(t)$  is unlikely to be tracked in single axis fashion.

Thus, motion cues will not be a potential handling qualities problem and the phase characteristics of  $a_{z_p}^a$  are entirely

irrelevant.

# Contrails

$$\frac{\theta}{F_s}(s) \approx \frac{K_c}{s^2} :$$

In either fixed base simulation or actual flight, closed loop stability is a problem because

$$\angle \frac{\theta}{F_s} = -180^\circ$$

Substantial lead equalization is required of the pilot, and handling qualities are poor. The pitch closed loop will be resonant at a low frequency—typically about 1/2 Hz. The effect of normal acceleration in actual flight will be destabilizing if

$$\angle \frac{a_{z_p}}{F_s}$$

is too negative. Closed loop dynamics will be insensitive to pilot technique in the control of pitch attitude because of the large slope

$$\frac{d}{d\omega} \left| \frac{\theta}{F_s} \right| = -40 \text{ db/decade}$$

## Effects of Motion Cues

Reference 2 identified  $\angle \frac{a_{z_p}}{F_s}(j\omega_c)$  as a principal parameter in evaluation of PIO susceptibility. The frequency  $\omega_c$  is any frequency at which closed loop pitch oscillations can be expected to occur with very small damping. Normal acceleration was cited as the dominant inertial cue and the only one necessary to consider;  $\ddot{\theta}$ , for example, can provide at most a "tweak" on pilot dynamics vis-a-vis those measured in a fixed base simulation of tracking.

# Contrails

It was indicated without comment above that  $\delta \frac{a_{z_p}}{F_s}(j\omega_c)$  will parameterize normal acceleration effects on basic short-period handling qualities. From Reference 2 it appears that when the phase angle

$$\phi(j\omega_c) = \delta \frac{a_{z_p}}{F_s}(j\omega_c) - 14.3\omega_c$$

becomes equal to or less than  $-180^\circ$ , PIO is a possibility. This presupposes that the pitch loop does resonate at frequency  $\omega_c$  radians/second. The phase angle  $\phi(j\omega_c)$  is the total phase angle of the closed loop system  $a_{z_p} \rightarrow F_s$ . Here we speculate that, so long as the pitch loop is resonant, either  $\phi(j\omega_c)$  or  $\delta \frac{a_{z_p}}{F_s}(j\omega_c)$  will parameterize the effect of  $a_{z_p}$  on handling qualities.

The implementation of the parameter  $\delta \frac{a_{z_p}}{F_s}(j\omega_c)$  requires that a rule exist for the determination of  $\omega_c$ . This must be suitable for use in a MIL-SPEC format. A suitable rule will be given in the next article.

In the above discussion the conceptual model for PIO<sup>2</sup> has been generalized to provide a model for the effects of motion on handling qualities for non-PIO cases. This was done, however, under the presumption that PIO results from pitch tracking. That is not always true.<sup>2</sup> Fortunately, it appears that the generalized criterion to be given in the next section--derived from closed loop considerations--will adequately treat the open loop control problem as well. For generality, the parameters  $\delta \frac{a_{z_p}}{F_s}(j\omega_R)$  or  $\phi(j\omega_R)$  could be investigated for suitability as metrics for motion cue effects. In the spirit of Reference 2, the frequency  $\omega_R$  should be the damped natural frequency of any airframe or FCS mode within a frequency range  $1 \leq \omega_R \leq 10$  radian/second for which the corresponding damping ratio is less than 0.2.

## F. PRACTICAL METHODS FOR SPECIFICATION DEVELOPMENT

It has been proposed above, based on considerable research, that for longitudinal handling qualities the dominant piloting cue is  $q = \dot{\theta}$ . This result is for VFR. For instrument-directed flight, the appropriate cue would be the first time derivative of the principal director cue.

We have suggested that the identification of reasonable handling quality metrics requires that we search for vehicle response properties to open loop control inputs which force the pilot to track; these, by the no-tracking hypothesis, will indicate off-optimum handling qualities. We expect, also, that these will generally correlate pilot opinion rating throughout the range of handling qualities.

For those cases where the pilot must track because of aircraft dynamics, a technique has been suggested for the identification of aircraft dynamics which result in adverse motion cue effects on handling qualities.

It only remains for us to reduce these concepts to specific criteria. The functional description of these will be made in the remainder of this section. These will be quantified against available flight test data in the next section.

### Basic Handling Quality Questions

The Cooper-Harper scale is based on the notion that a pilot employs a decision tree process in the evaluation of an aircraft's handling qualities. Among the questions that must be answered by the pilot, the most important are:

- Is the response to control too abrupt? sluggish?
- Does the aircraft response require considerable pilot compensation?

# Contrails

- Is the normal acceleration response consistent with the pitch response? Does it tend to "dig in" initially or overshoot the desired, final response?
- Is the aircraft PIO prone?

If the answer is yes to either of the first two questions, then it is probable that excessive tracking is required of the pilot in actual closed loop tasks such as fire control or in large amplitude maneuvering. In that case the final two questions will serve to quantify the extent of the handling qualities degradation from optimum.

We note that the first question is oriented to the time domain. It would be an unnecessary complication to reformulate this question into the frequency domain. Note, too, that an aircraft's response can be neither too sluggish nor too abrupt in response to control, yet still require excessive pilot compensation.

It should also be observed that with decoupled pitch and normal acceleration degrees of freedom (as with a DLC and digital FCS) these four basic questions still apply.

## Handling Qualities Criteria: Preliminary

- (1) Time-to-peak: The time to first peak  $t_q$  of the  $q(t)$  response to a step input in  $F_s$  (stick force) must lie between 0.2 seconds and some upper limit. For aircraft that have deadbeat  $q(t)$  response,  $t_q$  is defined to be the time to 90 percent of the steady state  $q$  value. Thus, require

$$0.2 \leq t_q \leq t_m$$

The value  $t_m$  must be determined from flight test data for those aircraft dynamics that are rated as too sluggish in their initial response.

# Contrails

The value  $t_q = 0.2$  seconds is specified since it represents an approximate lower limit on human pilot time delay for tasks typical of realistic flight control. If the response is so abrupt that  $t_q < 0.2$  seconds, then precision maneuvering will be impossible without pilot compensation, i.e., tracking; the pilot, in effect, would be made to "chase" the aircraft response.

The criterion on  $t_m$  should perhaps be a function of aircraft type and flight phase.

The connection between this criterion and  $C^*$  or TRP is noted. In essence, what we are saying here is that a time response history such as  $C^*$  or TRP is not generally necessary. It is sufficient that a portion of the time responses obey the simple peak criterion. Thus, there is a strong correlation between those criteria and that proposed here.

- (2) Level of Pilot Compensation: The phase lag of the pitch response control dynamics at a criterion frequency  $\frac{\theta}{F_s}(j\omega_c)$

must be established using available flight test data.

This relationship will be parameterized by  $\left. \frac{d}{d\omega} \left| \frac{\theta}{F_s}(j\omega_c) \right| \right|$

When the slope is too near zero, the phase angle will be irrelevant. When the slope is too large, in the negative sense, this implies excessive phase lag in a linear aircraft-FCS.

- (3) Sensitivity of Response to Pilot Technique: The slope of the amplitude ratio vs frequency for pitch dynamics,

$$\left. \frac{d}{d\omega} \left| \frac{\theta}{F_s}(j\omega_c) \right| \right|$$

must be greater (in the absolute sense) than that value for which closed loop dynamics are sensitive to small variations in pilot

# Contrails

technique or to periods of pilot inattentiveness. This limit must be chosen to satisfy available data. We anticipate that a zero slope will be too small (i.e., the pure gain controlled element case). This criterion and that on  $\delta \frac{\theta}{F_s}$  are strongly related for linear aircraft-FCS dynamics. Increasing amplitude ratio slope usually implies increasing phase lag, for example. However, according to the argument previously made, it is best to consider these effects separately since, in a time domain sense, they have differing connotations. When higher order system dynamics are present, amplitude and phase properties are independent to some extent at low frequency. This is clear from the equivalent systems model.

- (4) Motion Cue Effects: The phase angle  $\delta \frac{a_{zP}}{F_s}(j\omega_c)$  will be correlated with pilot opinion rating of motion cue effects (the pilot induced oscillation, PIOR, scale). The function

$$\phi(j\omega_c) = \delta \frac{a_{zP}}{F_s}(j\omega_c) - 14.3\omega_c \text{ degrees}$$

is proposed for use in the development of an actual handling qualities specification, since it is a central feature of the proposed PIO specification.<sup>21</sup> We anticipate that for Level 1 handling qualities, we must have  $\phi(j\omega_c)$  greater than  $-180^\circ$ --in the algebraic sense. The parameter

$$\left. \frac{d}{d\omega} \left| \frac{\theta}{F_s}(j\omega_c) \right| \right|$$

will be totally irrelevant to any relation between PIOR/POR and  $\phi(j\omega_c)$ . A certain amount of ingenuity will be required to quantify handling quality requirements for DLC when the pitching and normal acceleration degrees of freedom are decoupled. It is proposed that the rules given here will be suitable for interim requirements for DLC if only the definition of  $\omega_c$  is modified.

# Contrails

- (5) PIO: The PIO specification recommended in Reference 21 is adequate for all advanced FCS. It is merely the limiting form of the criterion for  $\phi(j\omega_c)$  to be quantified in Section VI,
  
- (6) Specification of  $\omega_c$ : This parameter is the criterion frequency; it is approximately equal to the crossover frequency of the pilot-aircraft system dynamics for the case of pitch attitude tracking. It is a function of aircraft dynamics and disturbance bandwidth. The data required for specification of  $\omega_c$ , contained in Reference 3, are shown in Figure 9; these are regarded by this author as irrefutable. Note that what we propose here is a specification for engineering design and acceptance--not a prediction of actual system dynamics.

The Reference 3 data are for single-axis, fixed-base tracking. The reader may question the use of such data for problems where motion cues or multiple loop tasks may have significant effect. The justification for ignoring motion cue effects for the specification of  $\omega_c$  is embodied in the No-Tracking hypothesis. The more significant the motion cues are to handling qualities, the more  $\omega_c$  may depart from the crossover frequency of Reference 3--which is totally irrelevant so long as the value for no motion can be successfully correlated with pilot opinion rating. The more significant the motion is to system dynamics, the more degraded the handling qualities. That, in essence, is justification enough for using  $\omega_c$  derived from fixed-base data. Multiple loop effects are of no interest here since our concern is with the specification of basic aircraft responses that are task-independent. Without good inner loop dynamics, good outer loop handling qualities are impossible to achieve.

We propose that the slope function

$$\left. \frac{d}{d\omega} \left| \frac{\theta}{F_s} (j\omega_c) \right| \right|$$



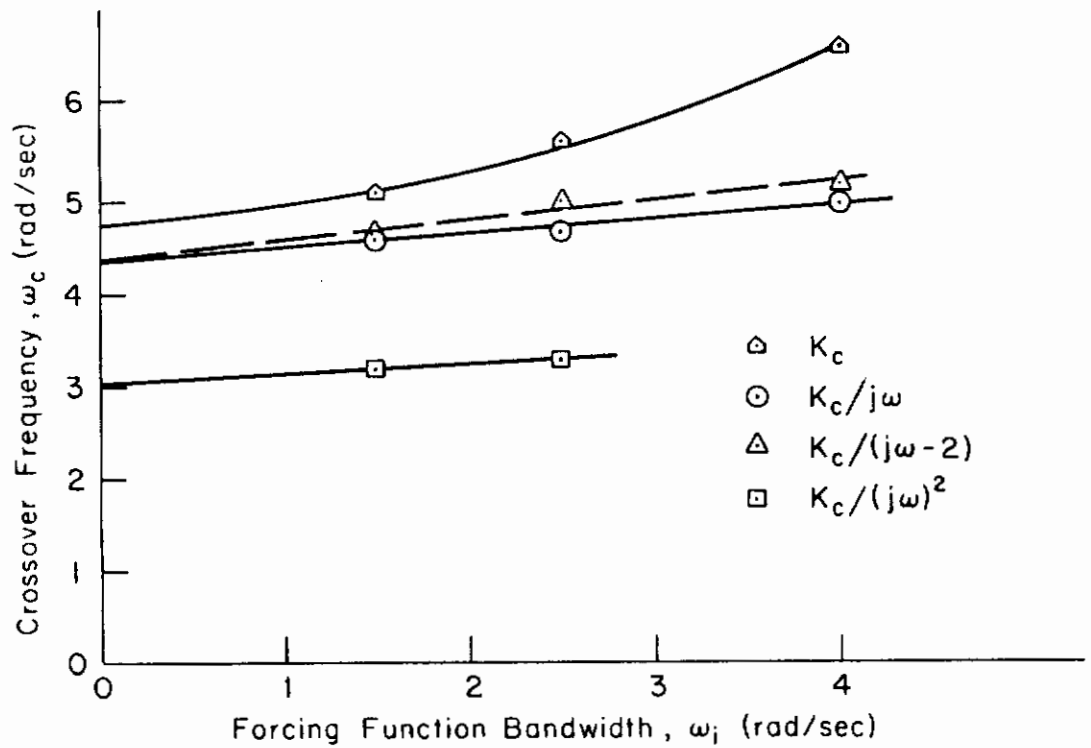

Figure 9. Variation of Crossover Frequency With Pitch Attitude Dynamics (From Reference 3)

# Contrails

is the best parameter for the specification of  $\omega_c$ . The phase of  $\frac{\theta}{F_s}$  could be used only if higher order system dynamics are not a factor--which, of course, contradicts the point of this entire report. The following empirical formulae, based on the data of Figure 10, are recommended for the specification of the criterion frequency  $\omega_c$ :

$$\left. \begin{aligned} \bullet \quad \omega_c &= 6.0 && \text{when } \frac{d}{d\omega} \left| \frac{\theta}{F_s}(j\omega_c) \right| \geq -1 \\ \bullet \quad \omega_c &= 0.27 \frac{d}{d\omega} \left| \frac{\theta}{F_s}(j\omega_c) \right| + 6.27 && \text{when } \frac{d}{d\omega} \left| \frac{\theta}{F_s}(j\omega_c) \right| \leq -1 \end{aligned} \right\} (10)$$

The units are radians/second and db/octave; the latter was chosen because it is convenient for computations with transfer function data given in numerical form. This specification is illustrated in Figure 10.

In lieu of a better alternative, the slope  $\frac{d}{d\omega} \left| \frac{\theta}{F_s}(j\omega_c) \right|$  is defined to be the average slope of  $\left| \frac{\theta}{F_s} \right|$  on the region  $2 \leq \omega \leq 6$ . The values of  $\omega_c$  calculated and shown in this report were obtained by averaging the slopes:

$$\Delta_1 = \left| \frac{\theta}{F_s}(4j) \right| - \left| \frac{\theta}{F_s}(2j) \right| \quad (\text{db})$$

$$\Delta_2 = \left| \frac{\theta}{F_s}(5j) \right| - \left| \frac{\theta}{F_s}(2.5j) \right| \quad (\text{db})$$

$$\Delta_3 = \left| \frac{\theta}{F_s}(6j) \right| - \left| \frac{\theta}{F_s}(3j) \right| \quad (\text{db})$$

$$\frac{d}{d\omega} \left| \frac{\theta}{F_s}(j\omega_c) \right| \triangleq \frac{1}{3} (\Delta_1 + \Delta_2 + \Delta_3)$$

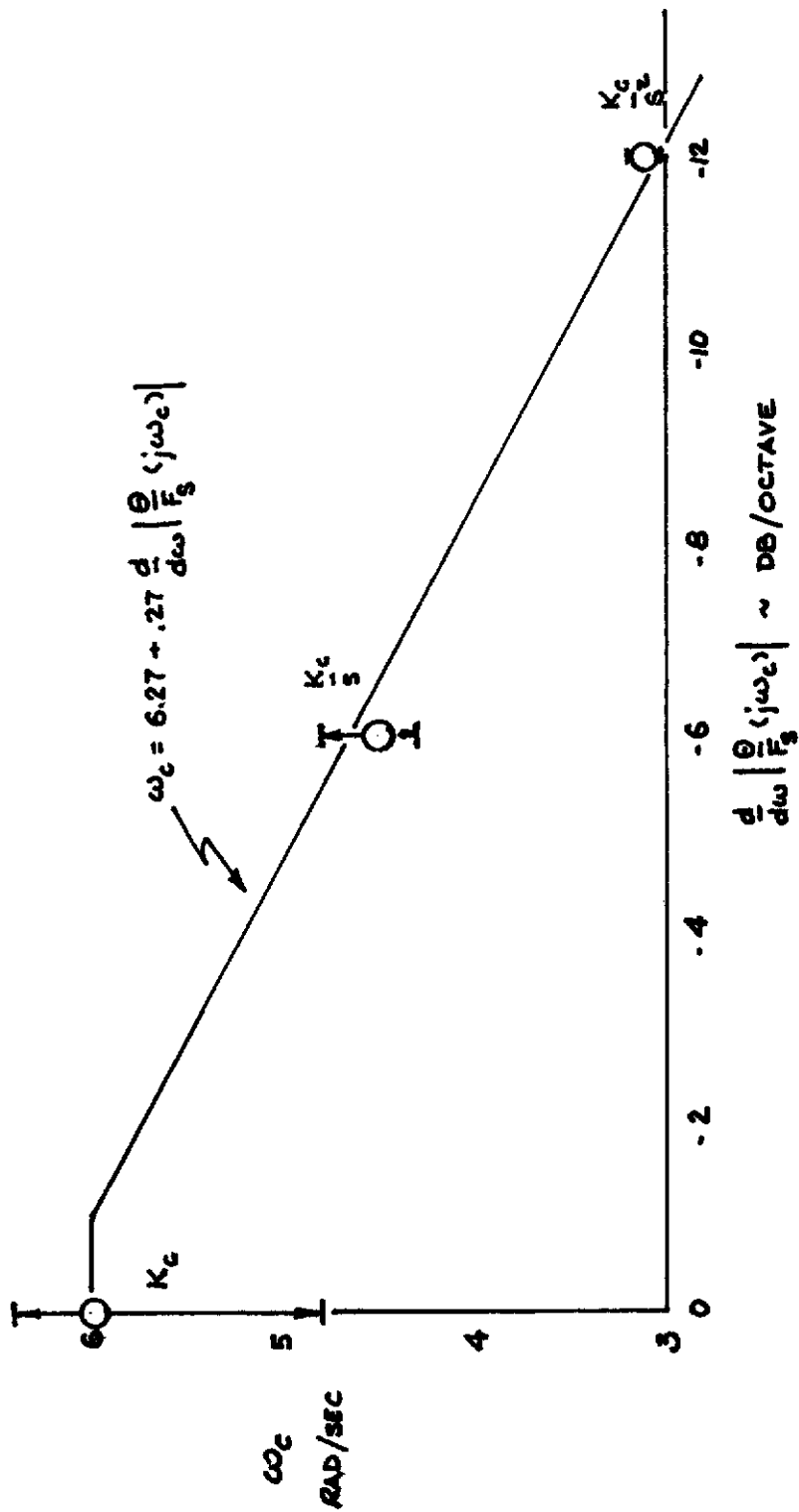

Figure 10. Specification of the Criterion Frequency

# Conclusions

For the data shown in this report the precise manner in which  $\omega_c$  is estimated is not usually critical. It can be, however. Unfortunately, we can offer no definitive rule for the estimation of  $\omega_c$  for those occasional cases where the slope of  $\left| \frac{\theta}{F_s} \right|$  varies considerably with small changes in  $\omega$ . For such cases, engineering judgment must be exercised with the criteria of this report used primarily as a guide. More recent work, not reported on these pages, suggests that it is probably better to simply be consistent in the method used for estimating  $\omega_c$  and not change the method to fit the situation.

The bandwidth specified by Neal and Smith<sup>6</sup> and by Mayhew<sup>21</sup> should be regarded as an oversimplification of the criterion frequency  $\omega_c$ . We submit that the a priori definition of bandwidth according to Flight Phase Category or aircraft class without regard for aircraft dynamics is too crude to be generally satisfactory for the development of handling qualities specifications.

The value  $\frac{d}{d\omega} \left| \frac{\theta}{F_s}(j\omega) \right| = -1$  was selected rather than 0 because it provides a better match with flight test data (Section VI).

- (7) Applicability to Flight Control Task: It is proposed that the specifications that are quantified in this and the next two sections will apply equally well to all flight control tasks for which precision control of attitude or flight path is a requirement. These include both tracking and nontracking tasks. Problems such as fire control during high-angle-off passes (typical of one-on-many engagements) are encompassed, we believe, by these specifications. The data available for the quantification of these specification proposals are strictly applicable to Class IV aircraft in Flight Phase Categories A and C.

*Contrails*  
 Section VI  
LONGITUDINAL SHORT-PERIOD  
HANDLING QUALITY REQUIREMENTS

A. APPROACH

In this section, the much referenced data base of Neal and Smith<sup>6</sup> will be examined once again. The perspective, however, will be that of Section V. The detailed calculations required for estimation of the various handling quality parameters will not be shown; the results are summarized in Table 9. All the data required for these calculations are contained in Reference 6 except for the normal acceleration dynamics; it is assumed that these obey the classic relationship,

$$\frac{a_{z_p}}{F_s}(s) = \frac{Z_{\alpha} s}{s + 1/T_{\theta_2}} \frac{\theta}{F_s}(s)$$

This assumption appears to be justified since the NT-33A variable stability airplane is not equipped with DLC and, apparently, did not employ a model-following simulation technique.

B. A PROPOSED TIME-TO-FIRST-PEAK SPECIFICATION

The data of Table 10 support as a criterion for Level 1

$$\boxed{0.2 \leq t_q \leq 0.9} \text{ , seconds} \tag{11}$$

where  $t_q$  is the time-to-first-peak of  $q(t)$  following application of a step in longitudinal stick force  $F_s$ . For an overdamped response  $t_q$  is the time to 90 percent of final value. The justification for the lower limit is based upon human reaction time delay considerations. When  $t_q < 0.2$ , the response is "too abrupt" and the pilot chases the  $q(t)$  response; i.e., he is forced to track, in violation of the No-Tracking hypothesis. When  $t_q > 0.9$  the response is too sluggish; the pilot will comment that "the initial motion" tends to "dig-in" or that the final response will "overshoot." This response is generally associated with excessive lag of  $\Re \frac{\theta}{F_s}(j\omega)$ .

TABLE 10. SUMMARY OF HANDLING QUALITY PARAMETERS (THE NEAL-SMITH DATA)

Case	$t_q$ (sec)	$\frac{d \theta }{d\omega} \frac{1}{F_s}$ (db/oct)	$\omega_c^*$ (/sec)	$\lambda \frac{\theta}{F_s} (j\omega_c)$ (deg)	$\phi(j\omega_c)^{**}$ (deg)	R	PIOR
1A	.56	- 9	3.8	-136	-163	6/4/5	2.5/1.5/2
1B	.58	- 8	4.1	-132	-208	3.5/3	1/1.5
1C	.65	- 8.5	4.0	-148	-169	5/3.5/4	2.5/2/1.5
1D	1.0	-11	3.2	-148	-225	5/4.5/3/4	2.5/2/1/2
1E	1.35	-13	2.7	-162	-178	6	3.5
1F	1.85	-15	2.2	-180	-280	8/8	4/4
1G	1.50	-15	2.2	-204	-296	8.5/8.5	4.5/4
2A	.26	- 1	6.0	-97	-171	4.5/4	2/2
2B	.35	- 2.0	6.0	-130	-204	6/6/4/4.5	2.5/3/1.5/2.5
2C	.24	- 3	5.5	- 89	-155	3	1.5
2D	.30	- 4	5.2	-107	-166	3/2.5/2.5	2/1/1
2E	.45	- 4	5.2	-131	-193	4	1
2F	.60	- 6	4.6	-143	-193	3	1
2G	.60	- 6	4.6	-168	-218	7	3
2H	.70	- 8	4.1	-157	-198	5/6/5.5	2.5/2.5/2
2I	.85	- 8	4.1	-179	-220	8/8	4.5/4
2J	3.0	- 9	3.8	-171	-207	6/6	2/2

TABLE 10. SUMMARY OF HANDLING QUALITY PARAMETERS (THE NEAL-SMITH DATA) (cont.)

Case	$t_q$ (sec)	$\left. \frac{d}{d\omega} \left  \frac{\theta}{F_s} \right  \right $ (db/oct)	$\omega_c^*$ (/sec)	$\angle \frac{\theta}{F_s} (j\omega_c)$ (deg)	$\phi (j\omega_c)^{***}$ (deg)	R	PIOR
3A	.15	- 1	6.0	- 63	-137	5/4/4/4	3/1.5/1/1.5
3B	.25	- 1	6.0	- 90	-164	4.5	2
3C	.30	- 3	5.5	-107	-173	4/3	2/1
3D	.35	- 5	4.9	-123	-178	4/4	2/1
3E	3.5	- 6	4.6	-137	-187	4/4	1.5/1
4A	.30	2	6.0	-135	-209	5.5/5	2.5/2
4B	.45	2	6.0	-162	-236	7	4
4C	.57	- 2	5.7	-175	-245	8.5	4
4D	.65	- 5	4.9	-168	-224	8/9	3.5/5
4E	.70	- 6	4.6	-173	-223	7.5	4
5A	.30	5.5	6.0	-144	-218	7/5/6	3/1.5/3
5B	.43	4.5	6.0	-171	-245	7	4
5C	.44	2	6.0	-194	-268	9/7	5/4
5D	.70	- 1	6.0	-221	-295	8.5/9/9	4/5/4
5E	.70	- 1	6.0	-234	-308	8/8	4/4
6A	.53	- 1	6.0	-132	-196	5/6	2/3
6B	.48	- 6	4.6	-118	-156	2.5/1/4	1.5/1/1.5
6C	.70	- 8	4.1	-136	-164	4/2.5/5	2.5/1/2

TABLE 10. SUMMARY OF HANDLING QUALITY PARAMETERS (THE NEAL-SMITH DATA) (cont..)

Case	$t_q$ (sec)	$\frac{d}{d\omega} \left  \frac{\theta}{F_s} \right $ (db/oct)	$\omega_c^*$ (/sec)	$\angle \frac{\theta}{F_s} (j\omega_c)$ (deg)	$\phi(j\omega_c)^{**}$ (deg)	R	PIOR
6D	.95	- 8	4.1	-162	-189	5.5	2.5
6E	1.25	-11	3.3	-168	-179	8.5/7	5/4
6F	2.8	-13	2.7	-186	-183	8/8.5/10	4/4/5
7A	.20	- 1	6.0	- 72	-136	5/4/2	2/2/1
7B	.18	- 2	5.7	- 75	-134	3	1.5
7C	.20	- 3	5.5	- 92	-147	3/3/4/1.5	2/2/1/1
7D	.30	- 4	5.2	-104	-154	5.5	3
7E	.45	- 5	4.9	-119	-163	3	1.5
7F	.63	- 5	4.9	-143	-187	{ 3/4/4-M 7/7/7-W	2/2/2-M -3.5/4-W
7G	.73	- 7	4.4	-149	-183	5/6	2/2
7H	2.5	- 9	3.8	-157	-179	5	2
8A	.10	- 2	5.7	- 51	-110	5/4	2.5/1
8B	.20	- 2	5.7	- 68	-140	3.5	1.5
8C	.21	- 3	5.5	- 86	-143	3.5/3	2/1
8D	.28	- 5	4.9	-107	-150	2/4	1/2
8E	2.17	- 8	4.1	-129	-157	2.5/3/5	1/1/2



TABLE 10. SUMMARY OF HANDLING QUALITY PARAMETERS (THE NEAL-SMITH DATA) (cont.)

Case	$t_q$ (sec)	$\left. \frac{d}{d\omega} \left  \frac{\theta}{F_s} \right  \right.$ (db/oct)	$\omega_c^*$ (/sec)	$\lambda \frac{\theta}{F_s}$ ( $j\omega_c$ ) (deg)	$\phi(j\omega_c)^{**}$ (deg)	R	PIOR
9	2.40	- 8	4.1	-127	-168	5/6	2/2
10	.95	- 8	4.1	-134	-175	4/4	1.5/1.5
11	.60	- 7	4.4	-121	-167	2.5/3	1/1
12	.15	- 1	6.0	- 62	-126	5/6/6	2.5/2.5/3
13	.15	- 1	6.0	- 44	-107	7/5.5	3/2.5
14	.10	- 1	6.0	- 34	-98	4.5/6	2/3

*ms lead  
first order approximation*

\* $\omega_c$  from Figure 9

\*\* $\phi(j\omega_c) = \lambda a z_p / F_s(j\omega_c) - 14.3 \omega_c$

Both of the limits proposed in (11) can be defended on a purely empirical basis. Figure 11 is a plot of Cooper-Harper rating (averaged for each case from Table 10) versus  $t_q$ . It is clear that no case has a Level 1 rating with  $t_q < 0.2$ ; the upper limit of  $t_q = 0.9$  seconds is not quite so firm because of the interaction of other parametric effects such as  $\Re \frac{\theta}{F_s}(j\omega_c)$  or  $\phi(j\omega_c)$ . Still, it appears to be a reasonable criterion for these data.

### C. A PROPOSED AMPLITUDE RATIO SLOPE CRITERION

Figure 12 is a plot of  $\Re \frac{\theta}{F_s}(j\omega_c)$  versus Cooper-Harper ratings (averaged for each case) for the Neal-Smith data from Table 10. The various symbols correspond to the slope parameter  $\left. \frac{d}{d\omega} \left| \frac{\theta}{F_s}(j\omega_c) \right| \right|$ . The criterion frequency  $\omega_c$  is computed according to Equation (10) and is shown in Table 10. The case number is indicated beside each data point.

It can be seen (with some study) that these data points divide consistently into three groups according to the slope of  $\frac{\theta}{F_s}(j\omega)$ :

- $\left. \frac{d}{d\omega} \left| \frac{\theta}{F_s}(j\omega_c) \right| \right| \geq -2 \text{ db/oct}$
- $-6 \leq \left. \frac{d}{d\omega} \left| \frac{\theta}{F_s}(j\omega_c) \right| \right| < -2 \text{ db/oct}$
- $\left. \frac{d}{d\omega} \left| \frac{\theta}{F_s} j\omega_c \right| \right| < -6 \text{ db/oct}$

The first group (slope  $\geq -2$  db/oct) yields degraded handling qualities; when  $\Re \frac{\theta}{F_s}(j\omega_c)$  is very small, the degradation is less, but handling qualities still are not Level 1. The explanation for this was given in the last section. The second group ( $-6 \leq$  slope  $< -2$  db/oct) yields good handling

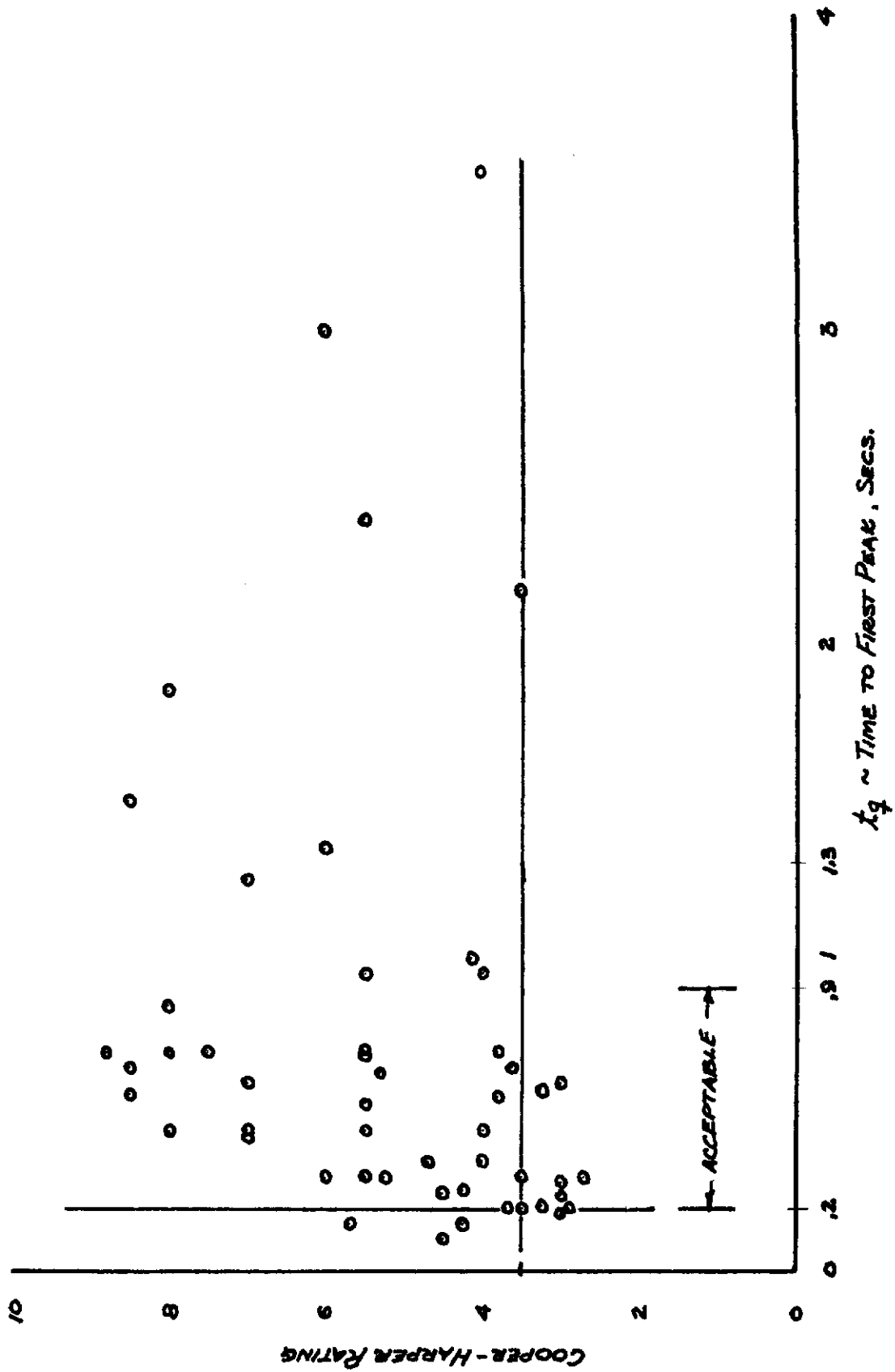

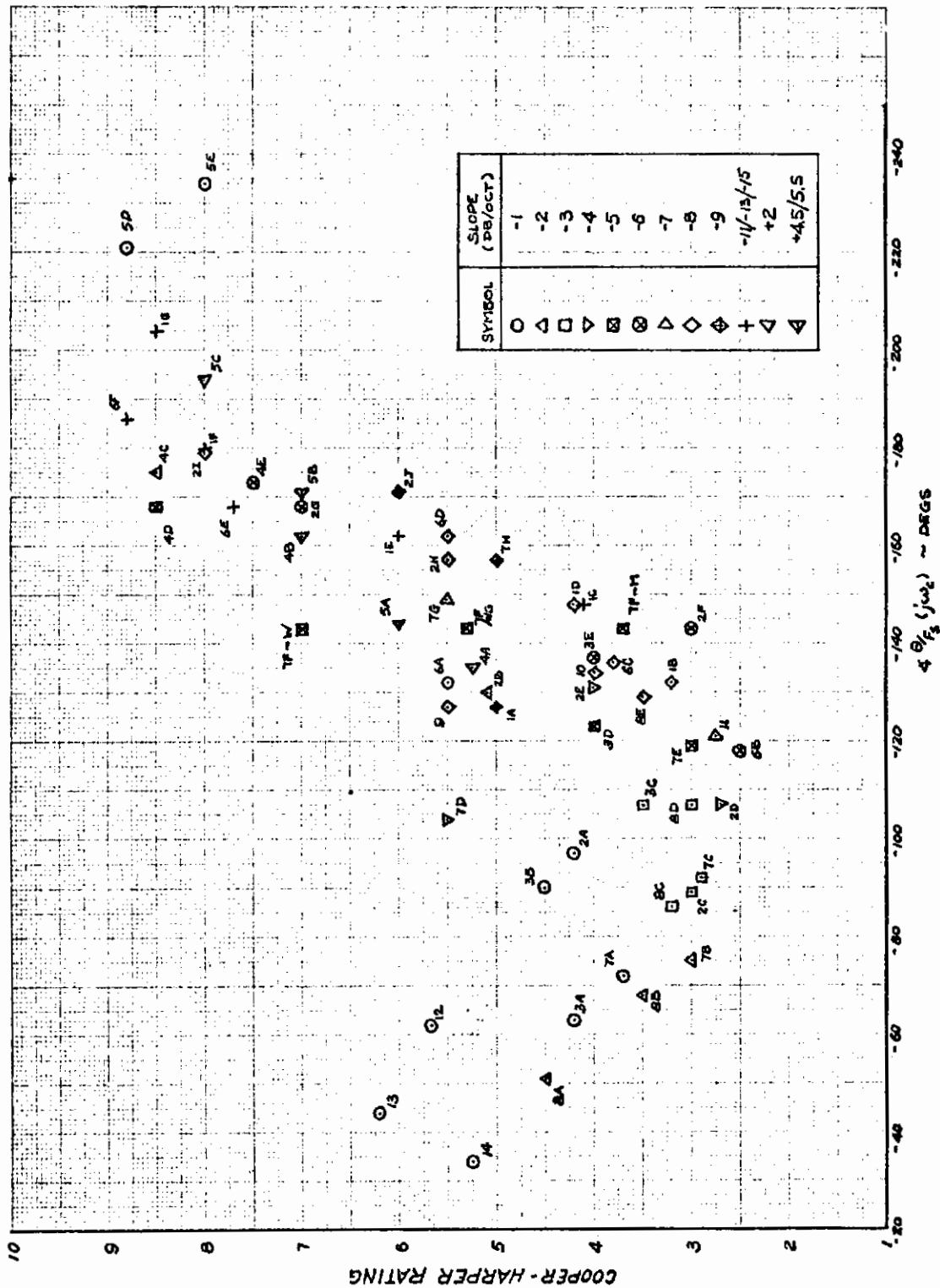

Figure 12. Aircraft-FCS Phase Angle at the Criterion Frequency vs Cooper-Harper Rating

# Contrails

qualities provided that  $\angle \frac{\theta}{F_s}(j\omega_c) > -130^\circ$ --then the airframe-FCS dynamics tested are most like those of a simple integration; i.e.,  $K_c/s$ .

The third group (slope  $< -6$  db/oct) corresponds to  $K_c/s^2$ -like dynamics for which the phase lag generally tends to be excessive.

These results confirm the behavior postulated in Section V. The slope  $\frac{d}{d\omega} \left| \frac{\theta}{F_s}(j\omega_c) \right|$  quite nicely parameterizes these data. In general, the importance to handling qualities of phase angle is hidden by variations in the slope parameter. In order to clarify this effect, the data of Figure 12 are replotted on Figure 13; however, all cases for which  $\frac{d}{d\omega} \left| \frac{\theta}{F_s} \right| \geq -2$  have been removed, but only if  $\angle \frac{\theta}{F_s}(j\omega_c) \geq -144^\circ$ . These are cases 2A, 2B, 3A, 3B, 4A, 5A, 6A, 7A, 7B, 8A, 8B, 12, 13, and 14. These are the cases for which the aircraft dynamics are similar to a pure gain; with the single exception of case 7B, none are Level 1. Apparently, it is this combination of near-zero slope and low phase lag that is most susceptible to the adverse effects on normal acceleration cues.

We therefore conclude that handling qualities are not generally Level 1 when  $\frac{d}{d\omega} \left| \frac{\theta}{F_s}(j\omega_c) \right| \geq$  about  $-2$  db/octave--regardless of  $\angle \frac{\theta}{F_s}(j\omega_c)$ . It is therefore proposed that for Level 1,

$$\boxed{\frac{d}{d\omega} \left| \frac{\theta}{F_s}(j\omega_c) \right| < -2 \text{ db/oct}} \quad (12)$$

This criterion and the phase angle criterion of the next paragraph are believed to apply for any FCS mechanization for which the pilot retains direct control of pitch attitude or fuselage pointing modes. Specifically,

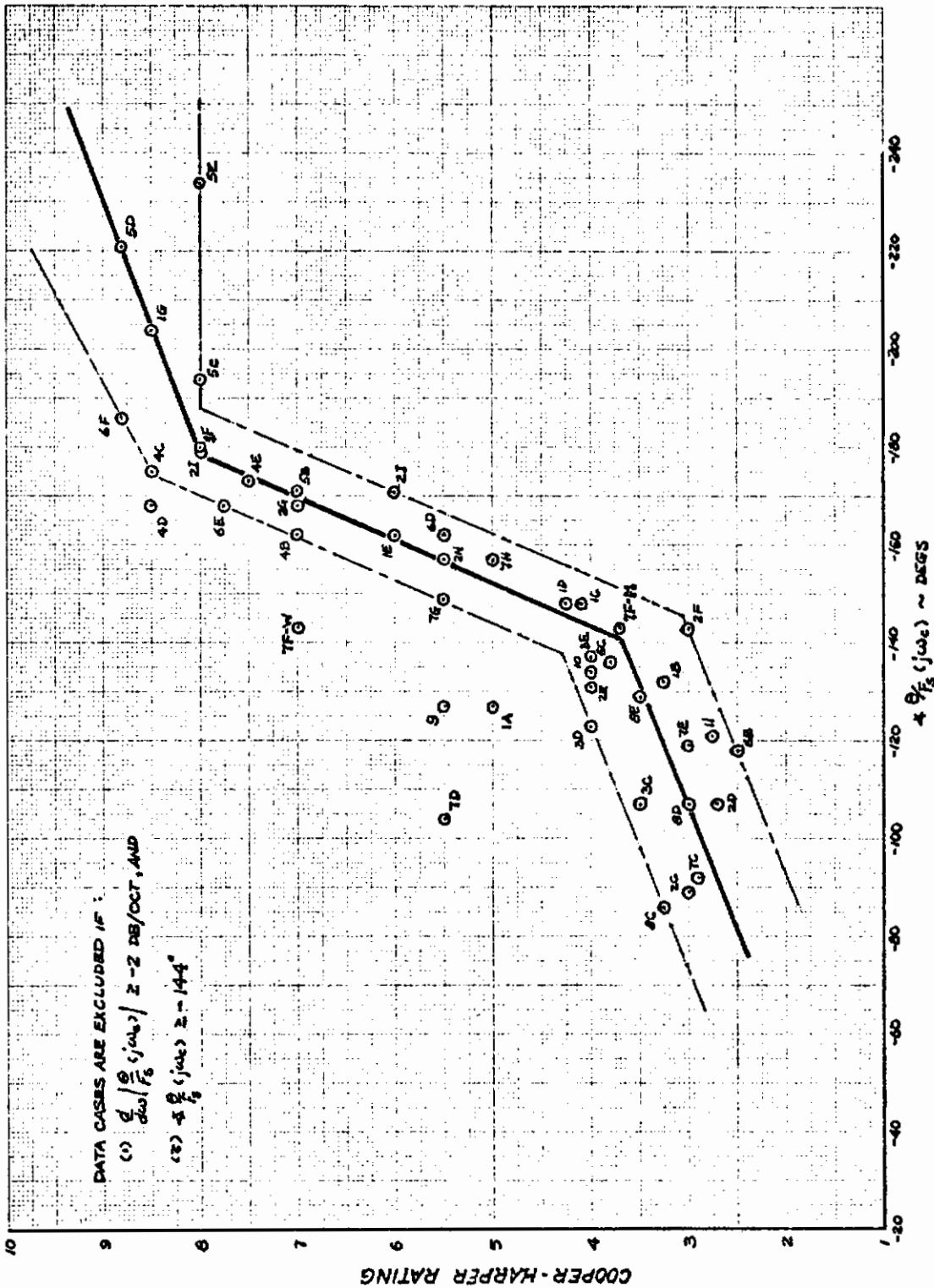

Figure 13. Design Guide Data for Effect of Phase Angle of Pitch Attitude Dynamics on Handling Qualities

it applies to the so-called maneuver-enhancement mode where DLC is coupled with pitch control to stiffen the flight path control response.

## D. A PROPOSED PHASE ANGLE SPECIFICATION

The data of Figure 13 indicate that a Level 1 boundary occurs at  $\angle \frac{\theta}{F_s}(j\omega_c) = -123^\circ$ , only case 7D fails to obey this boundary. If the boundary were set at  $-130^\circ$ , several more points rated as Level 2 would then lie in the Level 1 region. The Level 2 boundary seems to occur at  $-165^\circ$ ; all Level 2 and Level 3 data are correctly grouped by this boundary specification. It is noted that cases 1A and 9 are rated Level 2 by the  $-123^\circ$  limit on the Level 1 boundary. This might seem like an arbitrary division; however, both these cases are also categorized (correctly) as Level 2 by the acceleration phase specification of the next section.

The proposed specification for pitch attitude phase angle response may then be summarized as follows:

$$\begin{aligned} \text{Level 1: } & \angle \frac{\theta}{F_s}(j\omega_c) \geq -123^\circ \\ \text{Level 2: } & -130^\circ \geq \angle \frac{\theta}{F_s}(j\omega_c) \geq -165^\circ \\ \text{Level 3: } & \angle \frac{\theta}{F_s}(j\omega_c) \leq -165^\circ \end{aligned} \tag{13}$$

Although a Level 3 floor no doubt exists, it cannot be determined from the Neal-Smith data.

## E. A PROPOSED PHASE ANGLE SPECIFICATION FOR NORMAL ACCELERATION DYNAMICS

So long as the longitudinal control of flight path is principally effected through elevon/elevator commands (i.e., a single point controller)

# Contrails

it may seem irrelevant to impose a further limit on normal acceleration response.

However, with the use of additional control techniques (elevon plus canards or flaps, for example) the relation between pitching and heaving dynamics is determined by the FCS mechanization as much as by planform aerodynamics. The DLC F-8 and the CCV-YF-16 are but two examples of such systems that have been flight tested.

In the general case where the character of the FCS is unknown a priori it is desirable to develop a specification for normal acceleration response that is complementary to those given above for pitch response dynamics.

Throughout this report the difference between normal acceleration measured at the center of mass and at the pilot's location is ignored. Usually, this is negligible except for very large aircraft. For applications, when the difference is believed to be significant, the normal acceleration should be pilot-centered.

There is very little usable data available on the separate effects of heaving control and pitching control on handling qualities. What we propose is to dissect the Neal-Smith data so that, insofar as possible, the functional effects of these two degrees of freedom may be isolated. This will be accomplished via the following assumption:

## Assumption:

The pilot induced oscillation rating (PIOR) scale, as it was used by the pilot subjects in the Neal and Smith flight tests, is a measure of handling qualities degradation due to normal acceleration dynamics.

Since these flight tests, of necessity, varied both  $a_{z_p}$  and  $\theta$  dynamics simultaneously, it is not possible to directly assess the degradation due to motion; this can be done by implication, however.



# Contrails

The further assumption is made that PIOR = 1.5 corresponds to the natural Level 1 boundary, whereas PIOR = 3.5 corresponds to the Level 2 boundary. This assumption is based upon close inspection of the consistency between PIOR and Cooper-Harper rating (Figures 14 and 15) from the Neal-Smith data and with consideration for the adjectives used in the definitions of the two scales.

## Case 1: Conventional FCS or With Maneuver Enhancement

The function  $\phi(j\omega_c)$  is plotted in Figure 14 versus PIOR for all the Neal-Smith data cases except those which violate the  $t_q$  response criterion (Equation 11) or the slope criterion (Equation 13). These are cases 2A, 2B, 3A, 3B, 4A, 4B, 4C, 5A, 5B, 5C, 5D, 5E, 6A, 7A, 7B, 8A, 8B, 12, 13, and 14. These exclusions are made in order to preserve the basic PIOR- $\phi$  relationship and to enable the development of a necessary condition for handling qualities specification. By definition,

$$\phi(j\omega_c) = \angle \frac{a_{z_p}}{F_s}(j\omega_c) - 14.3 \omega_c$$

It must be observed that when motion cues are not degrading and when the Cooper-Harper rating is Level 1, then  $\phi(j\omega)$  is not a handling qualities parameter--it would be irrelevant for that condition. Thus any points in Figure 14 for which  $PIOR \leq 1.5$  and that are shown in the Level 2 region should be discounted provided that  $\angle \frac{\theta}{F_s}(j\omega_c) \geq -123^\circ$ . This eliminates cases 2D, 3C, 7E, and 11. Cases 2E, 3D, 3E, and 10 violate the  $\theta$ -phase criterion and are therefore appropriately classified as Level 2. Cases 1B and 2F are, in fact, Level 1 but are classified as Level 2 by both phase criteria.

With that clarification it is clear from Figure 14 that these data may be divided into the three regions shown. The other exceptional cases are discussed below:

Case 7D: The pilot's comments emphasized predictability of response and the difficulty of target acquisition. This might imply that the criterion

CONVENTIONAL FLIGHT PATH CONTROL  
OR MANEUVER ENHANCEMENT MODE

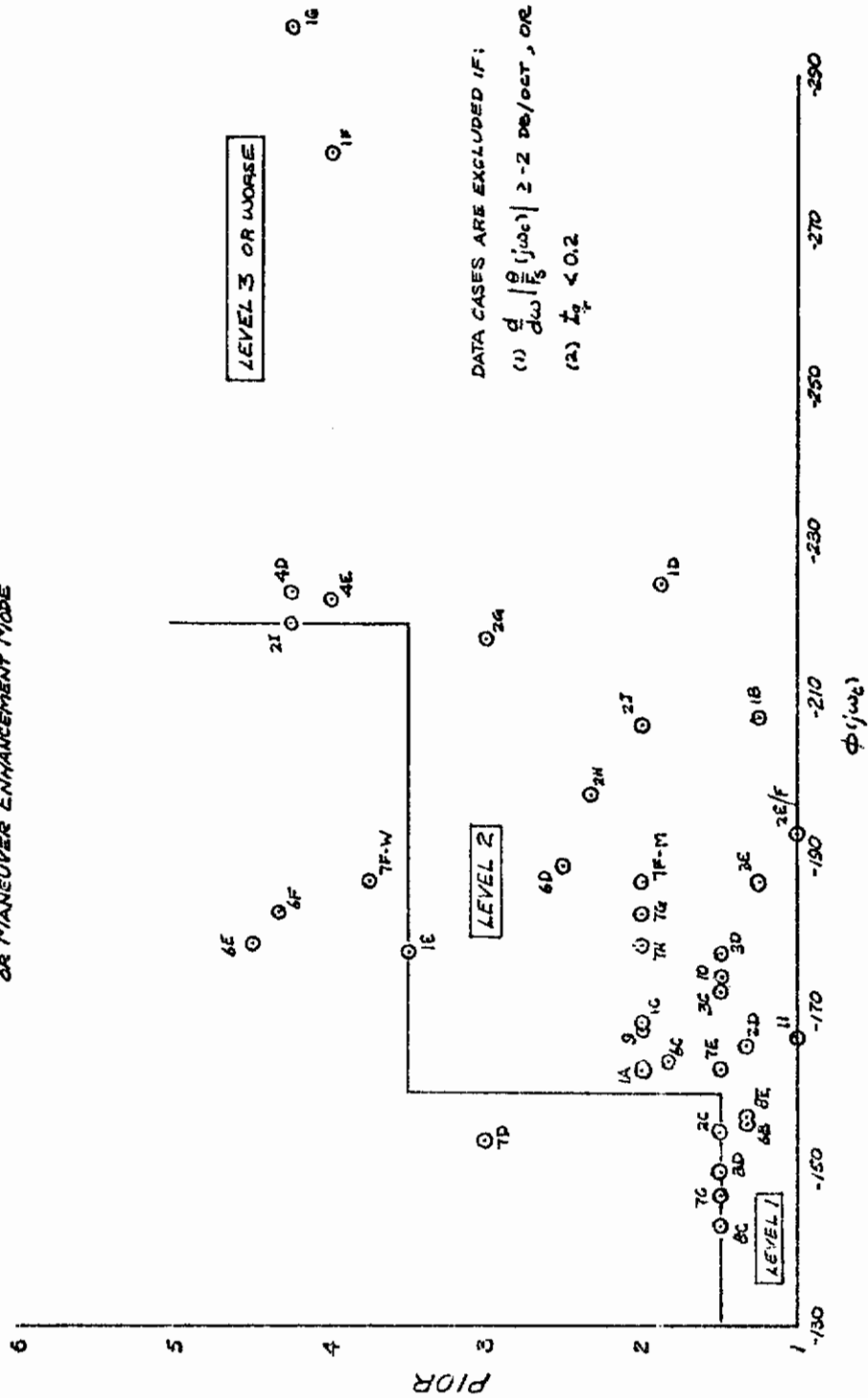

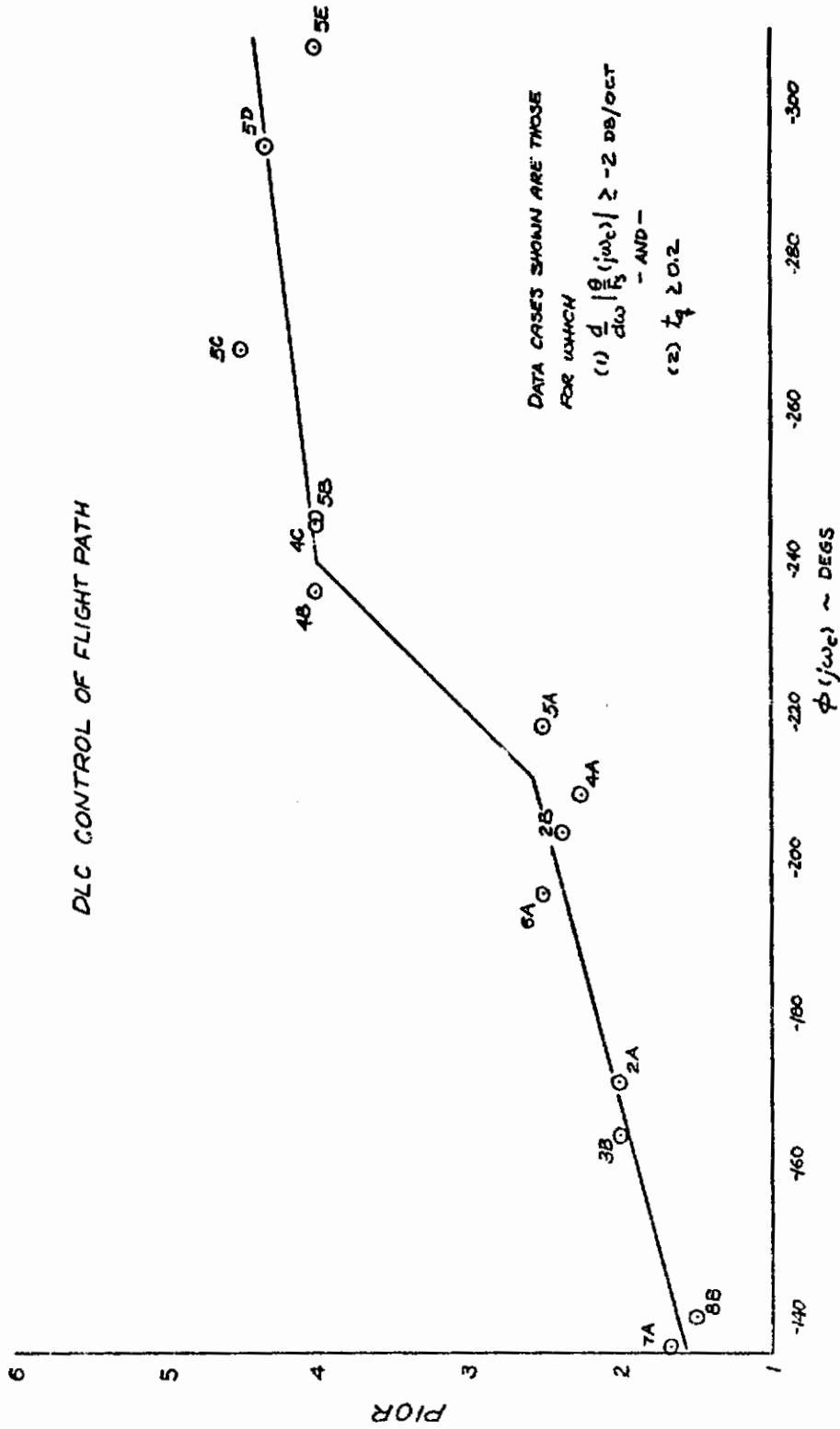

Figure 15. Acceleration Loop Phase vs PIOR: Direct Lift Control

# Contrails

frequency should be determined from the open loop airplane dynamics and be approximately equal to the short-period natural frequency (7.3 rad/sec). This possibility is supported also by the Cooper-Harper rating given for this case (5.5) and its inconsistency with  $\frac{\theta}{F_s}(j\omega_c)$ --Figure 12. When  $\omega_c = 7.3$  is used, this point is drawn into the Level 2 region of Figure 14.

Case 7F: This case is interesting because it appears to indicate how significant a test pilot's interpretation of task requirements can be to the Cooper-Harper rating or PIOR obtained. This case was tested by both pilots W and M. The results were as follows:

	<u>Cooper-Harper</u>	<u>PIOR</u>
Pilot M	3/4/4	2/2/2
Pilot W	7/7/7	-/3.5/4

The pilots were self-consistent and at complete variance with each other. The closed loop handling quality correlations for Pilot M are in excellent agreement with the results of Figures 12 and 14, whereas that for Pilot W would be consistent only if  $\omega_c$  were selected to be nearly equal to the airframe short-period natural frequency (7.3 rad/sec). This result is indicated on Figure 14 where it is seen to be well within the Level 3 region, as indicated by Pilot W's PIOR. Based on pilot comments,<sup>6</sup> it appears that Pilot M may have flown more "aggressively" with an emphasis on the time required for target acquisition. Pilot W appears to have based his evaluation on the tracking capabilities of the aircraft after target acquisition had been accomplished.

It is far from clear how such technique differences should be rationalized in a handling qualities specification. Here, we merely note that the theory for handling qualities appears to explain the results, provided that we fully consider the extremes of probable pilot technique.

We reiterate . . . the pilot rating differences obtained for this case are not evidence that pilot evaluations are inadequate. Quite the contrary. They seem to imply that we must become more sophisticated in the use of the

# Contrails

Cooper-Harper scale and in the design of experiments for the collection of handling qualities data.

Cases 6E and 6F: Both these cases are properly categorized as Level 3 according to the  $\theta$ -phase criterion; for that reason, they should be discounted in establishing the recommended acceleration phase boundaries shown in Figure 14.

Case 1D: At the Level 2 boundary Case 1D violates the  $\phi$  criterion of  $\phi \geq -220^\circ$  but is rated as Level 2 ( $\overline{\text{POR}} = 4.1$ ). Comparison of the  $\frac{\theta}{F_s}$  values for Cases 1D, 2G, 2I, 4E, and 4D--all of which have similar  $\phi$ --suggests that violations of the Level 2 criterion on  $\phi$  should be classified as Level 2 whenever  $\frac{\theta}{F_s} \geq -148^\circ$ . This restriction is based primarily upon Case 1D and should be subjected to further flight tests.

Based upon the correlation obtained in Figure 14, it is proposed that for conventional FCS design or when maneuver enhancement is employed the following requirements be met:

Level 1: $\phi(j\omega_c) \geq -160^\circ$	
Level 2: $-160^\circ > \phi(j\omega_c) \geq -220^\circ$	(14)
Level 3: $-220^\circ > \phi(j\omega_c) \geq ?$ (no data)	

## Case 2: Direct Lift Control Modes

It was assumed in the last section that those aircraft which violate the slope criterion (Equation 13) correspond to those for which the essential handling qualities problem is due to the adverse effects of motion cues. In this section, we wish to pursue this idea to establish the basic connection between aircraft-FCS dynamics and handling qualities degradation due to motion.

# Contrails

If we plot  $\phi(j\omega_c)$  vs PIOR for only those aircraft-FCS cases from the Neal-Smith data which violate only the slope criterion (i.e., for which  $\frac{d}{d\omega} \left| \frac{\theta}{F_s} \right| > -2$  db/oct but  $0.2 < t_q < .9$ ) then the resulting trend will apply regardless of pitch dynamics. In particular, it will apply when a DLC system is employed--for which  $\theta$  may be automatically controlled, for example.

The cases for which the slope criterion of Equation 13 is violated, but for which the q-response time criterion (Equation 11) is satisfied are:

2A, 2B, 3B, 4A, 4B, 4C, 5A, 5B, 5C, 5D, 5E, 6A, 7A, and 8B

For these cases  $\phi(j\omega_c)$  is plotted vs PIOR in Figure 15. A strong correlation appears to exist.

Based upon the data of Figure 15, it is proposed that suitable new handling qualities criteria for DLC are:

Level 1: $\phi(j\omega_c) \geq -130^\circ$	
Level 2: $-130^\circ > \phi(j\omega) \geq -230^\circ$	(15)
Level 3: $-230^\circ > \phi(j\omega) > ?$ (no data)	

In addition, when the task is power approach, the criterion on flight path angle response of the next section is imposed.

For tasks such as aerial refueling and formation flight, in which relative position is important, it is proposed that the dynamics of the first time derivative of  $x$  (where  $x$  is the relative, vertical displacement from a target position) be treated similarly to  $\theta$  for conventional flight control; viz., require

$$\left. \frac{d}{d\omega} \left| \frac{\dot{x}}{F_s}(\omega_c) \right| \right| < -2 \text{ db/octave} \quad (16)$$

It provides an interesting and useful tie with classic man-machine system dynamics to note that for the typical bandwidths of position control dynamics--for example,  $\omega_c \cong 3.0$ --the proposed Level 1 specification of (15) indicates that linear aircraft-FCS dynamics in the DLC mode must be similar in form to  $K_c/s$ . The specification is not quite so restrictive as the classic requirement at higher bandwidths. This comparison is valid provided it is assumed that the pilot's principal visual cue is  $\frac{dx}{dt}$  -- i.e., relative velocity.

#### F. A COMMENT ON THE PIOR SCALE

It has been suggested by some that the PIOR scale (Figure 16) is redundant--that it contains no information that cannot be obtained from the Cooper-Harper scale. The scale does not appear to be widely used and is falling into disuse at flight test organizations that have previously employed it.

We do not agree that the PIOR scale is necessarily redundant, although there is clearly some redundancy with the Cooper-Harper scale "built-in" by the choice of rating descriptors. The basis for this position lies partly in the success demonstrated in the last paragraphs in correlating  $\phi(j\omega_c)$  with PIOR; the data correlation was essentially 100 percent. Partly, too, this judgment is based upon a sense of how an evaluation pilot perceives the interpretation of the Cooper-Harper and the PIOR scales vis-a-vis the piloting tasks.

The Cooper-Harper scale (Figure 17) emphasizes the ability of a pilot to perform a control task and the effort required for this. In actual flight, the scale therefore interleaves the individual control modes associated with attitude and normal acceleration. Except in near-PIO cases, however, the motion cue loops are probably not strongly coupled with the measures of tracking performance that the pilot may be asked to evaluate. Thus, motion control--when it exists--can degrade the pilot's subjective evaluation of handling qualities with insignificant effect on piloting performance.

DESCRIPTION	NUMERICAL RATING
NO TENDENCY FOR PILOT TO INDUCE UNDESIRABLE MOTIONS	1
UNDESIRABLE MOTIONS TEND TO OCCUR WHEN PILOT INITIATES ABRUPT MANEUVERS OR ATTEMPTS TIGHT CONTROL. THESE MOTIONS CAN BE PREVENTED OR ELIMINATED BY PILOT TECHNIQUE.	2
UNDESIRABLE MOTIONS EASILY INDUCED WHEN PILOT INITIATES ABRUPT MANEUVERS OR ATTEMPTS TIGHT CONTROL. THESE MOTIONS CAN BE PREVENTED OR ELIMINATED BUT ONLY AT SACRIFICE TO TASK PERFORMANCE OR THROUGH CONSIDERABLE PILOT ATTENTION AND EFFORT.	3
OSCILLATIONS TEND TO DEVELOP WHEN PILOT INITIATES ABRUPT MANEUVERS OR ATTEMPTS TIGHT CONTROL. PILOT MUST REDUCE GAIN OR ABANDON TASK TO RECOVER.	4
DIVERGENT OSCILLATIONS TEND TO DEVELOP WHEN PILOT INITIATES ABRUPT MANEUVERS OR ATTEMPTS TIGHT CONTROL. PILOT MUST OPEN LOOP BY RELEASING OR FREEZING THE STICK.	5
DISTURBANCE OR NORMAL PILOT CONTROL MAY CAUSE DIVERGENT OSCILLATION. PILOT MUST OPEN CONTROL LOOP BY RELEASING OR FREEZING THE STICK.	6

Figure 16. The Pilot Induced Oscillation Rating (PIOR) Scale



# Contrails

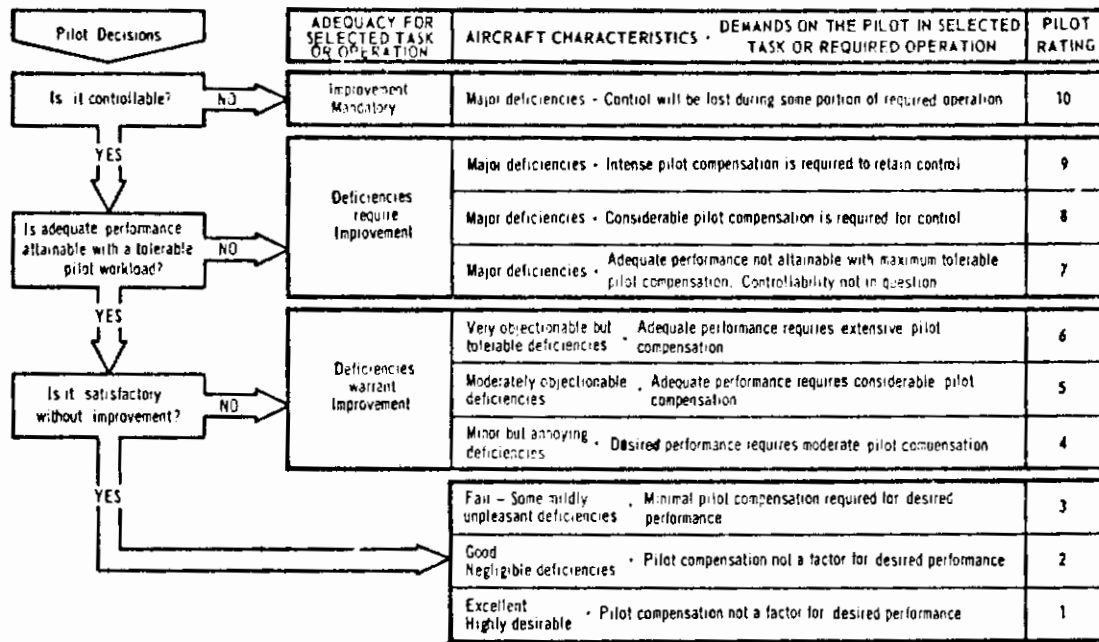

Figure 17. The Cooper-Harper Scale

# Contrails

The PIOR scale does not directly address task performance. It is a scale only for the quantification of handling qualities degradation due to motion cue effects.

While the scales may be closely connected they do appear to be more complementary than redundant. The development of the criteria based on  $\phi(j\omega)$  would not have been possible without the PIOR data from Reference 6.

The Cooper-Harper scale is a bounded and, therefore, nonlinear scale. The effects of its nonlinear nature may be seen in the  $\sigma_{\beta q}$  vs POR correlation (Figure 3) and, in the data of Figure 12 for  $\frac{\theta}{F_s}(j\omega_c)$  vs POR. The PIOR scale seems very nonlinear because it is more truncated (6 points rather than 10). Thus, the correlations of  $\phi(j\omega_c)$  with PIOR (Figures 14 and 15) are distorted to account for this. The PIOR scale emphasizes "undesirable motions" or "oscillations." Rather than dispense with the PIOR scale we propose that it be revised as follows:

- Change its name to reflect its probable use; i.e., it is used for rating the significance to control difficulty of motion cue effects.
- Increase the scale to 10 points to increase its linearity and to permit more sensitive comparisons to be made of the separate effects of performance, workload and motion cues.
- Devise descriptors for each numerical rating that will tend to linearize the scale.

For the sorts of advanced FCS concepts that are considered in this report, data obtained from a scale of this sort would be an ideal complement to Cooper-Harper ratings.

## G. A COMMENT ON THE USE OF EQUIVALENT SYSTEMS TIME DELAY AS A HANDLING QUALITIES METRIC

The Level 1 phase criterion  $\angle \frac{\theta}{F_s}(j\omega_c) \geq -123^\circ$  (Equation 13) can be used to estimate the maximum allowable time delay based upon the equivalent systems model for pitch response, viz.,

$$\frac{\theta}{F_s}(s) = \frac{K_\theta s + 1/T_E}{s s^2 + 2\zeta_E \omega_E s + \omega_E^2} e^{-\tau_E s}$$

The Level 1 requirement given in Paragraph D, above, is

$$\angle \frac{\theta}{F_s}(j\omega_c) \geq -123^\circ$$

Using the equivalent systems model this implies that

$$(\tau_E)_{\max} = \frac{1}{57.3\omega_c} \left[ 40 + \tan^{-1}\left(\frac{\omega_c}{1/T_E}\right) - \tan^{-1}\left(\frac{2\zeta_E \omega_E \omega_c}{\omega_E^2 - \omega_c^2}\right) \right] \quad (17)$$

where  $\omega_c$  must be estimated by the formula

$$\omega_c = 6.27 + .27 \frac{d}{d\omega} \left| \frac{\theta}{F_s}(j\omega) \right| \quad \text{for } \frac{d}{d\omega} \left| \frac{\theta}{F_s}(j\omega) \right| \leq -1 \text{ db/oct}$$

or

$$\omega_c = 6.0 \quad \text{for } \frac{d}{d\omega} \left| \frac{\theta}{F_s}(j\omega) \right| > -1 \text{ db/oct}$$

If  $\zeta_E$ ,  $\omega_E$  and  $1/T_E$  are known, then the average slope of  $\frac{\theta}{F_s}(j\omega)$  can be estimated; this fixes  $\omega_c$ . With this value known,  $(\tau_E)_{\max}$  can be determined from (17). The results in the following table were obtained by this procedure:

# Contrails

$\frac{1}{T_E} = 1.0$		
$\zeta_E = 0.5$		
$\omega_E$	$\omega_c$	$(\tau_E)_{\max}$
2	2.9	- .042
4	5.1	.009
6	6.0	.089
9	6.0	.205

These examples are believed to be representative of actual flight test and simulation experiences. The effects of  $1/T_E$  and  $\zeta_E$  are secondary in comparison to the relative values of  $\omega_E$  and  $\omega_c$ .

For the first example in the table,  $(\tau_E)_{\max} = -.042$  seconds; i.e., this configuration cannot meet the phase criterion. For the other cases, it can be seen that  $(\tau_E)_{\max}$  is very strongly dependent on  $\omega_E$ .

It has been suggested by others in private discussions that a reasonable specification might be  $\tau_E \leq 0.1$  seconds; Reference 20 proposes 0.12 sec for Flight Phase Category A, Level 1. The results here support that to a certain extent. However, it appears that there are two basic objections to a requirement of this sort:

- (1) It is too simplistic. It may be either too conservative or not conservative enough depending on aircraft-FCS dynamics.
- (2) The parameter  $\tau_E$  may be very sensitive to the method by which the equivalent systems model is derived.

The latter possibility is sufficient reason to discard this simplified approach to handling qualities specification.

## H. SUMMARY OF PROPOSED REQUIREMENTS

The requirements proposed are restricted to longitudinal mode, short-period dynamics of Class IV aircraft, Flight Phase Category A and, we believe, the terminal phase of landing.

(1) Time response:

Level 1:  $0.2 \leq t_q \leq 0.9$

Level 2: none proposed

(2) Slope criterion:

$$S \triangleq \frac{d}{d\omega} \left| \frac{\theta}{F_s}(j\omega_c) \right| \text{ db/oct}$$

Level 1:  $S < -2 \text{ db/oct}$

Level 2: none proposed

(3)  $\theta$ -phase lag:

Level 1:  $\angle \frac{\theta}{F_s}(j\omega_c) \geq -123^\circ$

Level 2:  $\angle \frac{\theta}{F_s}(j\omega_c) \geq -165^\circ$

(4)  $a_n$ -phase lag--conventional flight path control or maneuver enhancement modes:

Level 1:  $\phi \geq -160^\circ$ , for any value  $\angle \frac{\theta}{F_s} \geq -130^\circ$ , or any  $\phi$  when  $\angle \frac{\theta}{F_s} \geq -122^\circ$

Level 2:  $\phi \geq -220^\circ$ , for any value  $\angle \frac{\theta}{F_s} \geq -165^\circ$ , or any  $\phi$  when  $\angle \frac{\theta}{F_s} \geq -148^\circ$

(5)  $a_n$ -phase lag--DLC control of flight path:

Level 1:  $\phi \geq -130^\circ$

Level 2:  $\phi \geq -230^\circ$

The  $\theta$ -phase is irrelevant for this case.

# Contrails

These requirements comprise a set of necessary conditions. Each must be satisfied at the Level 1 or 2 values if longitudinal handling qualities are to be Level 1 or 2, respectively. Violation of any one will make the handling qualities equal to the level for which the violation exists.

## I. HANDLING QUALITY REQUIREMENTS FOR DISPLAY DESIGN

For piloting tasks which require that the pilot track a displayed cue  $x$  (which may be any cue or combinations of cues that are displayed explicitly), the results given in Paragraphs B, C and D are thought to apply equally well if  $x$  is substituted for  $\theta$  and  $\dot{x}$  for  $q$ . That is, we require that

(1)	$0.2 \leq t_x \leq 0.9$ seconds	Level 1	
(2)	$\angle \frac{x}{F_s}(j\omega_c) \geq -123^\circ,$	Level 1	
	$-123^\circ \geq \angle \frac{x}{F_s}(j\omega_c) \geq -165^\circ,$	Level 2	
	$\angle \frac{x}{F_s}(j\omega_c) \leq -165^\circ,$	Level 3	(18)
(3)	$\left. \frac{d}{d\omega} \left  \frac{x}{F_s}(j\omega_c) \right  \right  < -2$ db/octave,	Levels 1 and 2	

where the criterion frequency  $\omega_c$  is computed by Equation 10, as before.

It is presumed that the pilot's essential task is to control the excursions of  $x(t)$ . The display by which this is accomplished could resemble the HUD concept of Figure 8, previously discussed.

The difficulty posed to the display designer by these specifications is that the dynamics represented by  $\frac{x}{F_s}(s)$  involve the airframe and FCS dynamics, also. In fact, for conventional displays such as an Attitude Director Indicator (ADI), the dynamics of  $\frac{x}{F_s}(s)$  are (or should be) nearly identical

# Contrails

with those of the aircraft plus FCS; i.e., we have not been accustomed to dealing with primary displays which purposely introduce dynamic elements into the man-machine system loop for the purpose of accomplishing a task or for handling qualities enhancement. The usual problem of display design has been to eliminate display dynamics, insofar as possible.

This scenario will probably change with the introduction of digital computer generated displays; that proposed by Bateman<sup>28</sup> is but one example. In order to generate Bateman's display, a tremendous amount of data acquisition (from a multitude of sensors), data processing, and sheer number-crunching must be accomplished by one or several digital computers. Because of the computational time required and practical limitations on frame rates, display dynamics that are nontrivial to handling qualities appear to be inevitable in some likely applications.

When significant nonlinearities (intentional or unintentional) are present in the display these must be accounted for in the application of specifications (18). It is beyond the scope of this report to show how this may be done.

The requirements proposed in (18) implicitly require that the aircraft-FCS-display dynamics be similar in time-wise character to conventional attitude dynamics. When the only displayed cue is one derived from flight path, for which the required bandwidth is much smaller than that given by  $\omega_c$  from Equation 10, then these requirements cannot be applied directly. However, for such cases the flight path stability requirements of the next section should also be appropriate as specifications for display design.

The entire issue of the design of computer generated displays should be carefully and systematically addressed from the viewpoint of handling qualities impact. It is far from clear how a HUD concept such as that of Bateman (Figure 8) should be implemented. Those considerations related to multimode FCS further complicate the display problem.

# Contrails

## SECTION VII

### FLIGHT PATH STABILITY IN POWER APPROACH

#### A. NECESSITY FOR A NEW SPECIFICATION

Paragraph 3.2.1.3 of MIL-F-8785B establishes limits on the variation of flight path angle  $\gamma$  with airspeed in power approach. This assumes that  $d\gamma/dV$  represents a measure of flight path "stability" resulting from small changes in airspeed due to the use of elevator control, only (throttle control is fixed for application of this specification).

This specification has been criticized, both because aircraft with deficient handling qualities satisfy it and vice versa. In general, it seems that transport aircraft seem to obey the current specification but that it is clearly inadequate for Class IV aircraft.

Whatever its value to design might be, the  $d\gamma/dV$  specification may not adequately encompass the range of pilot technique for glide slope control. Throttle, in general, is an important flight path control. Navy doctrine, in fact, requires that the principal glide slope control cue for carrier-approach -- the "meatball" of the Fresnel Lens Optical Landing System -- be controlled with throttle. USAF pilots are not similarly constrained. Differences between the two service philosophies are due, of course, to back-side vs front-side power approach operations.

The Background Information and User Guide for MIL-F-8785B<sup>31</sup>, notes several references that demonstrate how constant-throttle, altitude-hold dynamics, with the pilot in the loop, are destabilized when the elevator transfer function numerator zero  $1/T_{h1}$  becomes too negative. To a good approximation,

$$1/T_{h1} = 1/m \, dD/dV$$

where  $D$  is the total drag. The zero  $1/T_{h1}$  is therefore negative only the back-side of the drag-velocity curve. (Total drag  $D$  equals net drag minus thrust times cosine  $\zeta$ ; and steady-state  $V$  in straight flight is regulated by elevator control alone.)



# Contrails

MIL-F-8785B places limits on  $d\gamma/dV$  at constant throttle setting with airspeed changes effected only with elevator. These are from Paragraph 3.2.1.3:

Level 1;  $\frac{d\gamma}{dV} < 0.06$  degrees/knot

Level 2;  $\frac{d\gamma}{dV} < 0.15$  degrees/knot

Level 3;  $\frac{d\gamma}{dV} < 0.24$  degrees/knot

The derivatives are to be measured at  $V_{0_{min}}$ . Also, at a speed 5 knots slower than  $V_{0_{min}}$ ,  $d\gamma/dV$  shall not be more than 0.05 degrees/knot more positive than the slope at  $V_{0_{min}}$ .

This requirement is intended to restrict the magnitude of  $dD/dV$  and thereby limit the degree of pilot-aircraft instability that can result from the use of elevator to control altitude errors. This, presumably, would influence the level of throttle activity required for control of airspeed.

This requirement has two potential shortcomings. It implies that handling qualities can be discriminated according to factors related to the closed-loop piloted control of altitude with elevator. It presupposes that altitude cues exist, are available to the pilot, and are of sufficient quality to sustain precision closed-loop control. For back-side approaches, throttle control of flight path is the more likely technique -- it is optional for the front-side approach. Finally, altitude, per se, is not usually present as a cue for closed-loop control. Even for carrier approach, the visual display is of path angle error -- not altitude. Acceptable altitude error is a range-dependent function; tolerances on path angle error are (approximately) constant. It is noted that the results of Reference 14 support the conclusion that it is short-period dynamics -- not phugoid -- which dominate pilot-aircraft system dynamics in carrier approach.

In this section, we shall attempt to establish a rational correlation between the proposed short-period requirements for handling qualities (Section VI) and additional, necessary requirements for power approach. First, let us briefly review some specific case history data; these support the contention that MIL-F-8785B requires revision and offer some insight into where its deficiencies lie.

# Contrails

Reference 32 summarizes a McDonnell-Douglas study of the F-4 series aircraft. Four models of the F-4 were included: the F-4B and F-4M models, which have identical airframes but different engines, and the F-4J and F-4K models, which also have identical airframes (but different from the B and M models) and different engines. The four models comprise a matrix of two airframes and two engines.

The F-4B/M airframe at  $V_{O_{min}} = 138$  kt has  $\frac{dy}{dV} = -0.01$ ; at  $V_{O_{min}} -5$ ,  $\frac{dy}{dV} = +0.01$ . It therefore meets the present Level 1 requirement. However, large differences exist in the pilot ratings of the F-4B and F-4M handling qualities in power approach. The F-4B, powered with two J79 turbojets, has consistently received Level 1 pilot ratings by Navy pilots. The F-4M, powered with two Rolls-Royce Spey turboprops, was rated 6 on the Cooper-Harper scale -- near the Level 2 boundary.

The F-4J/K airframe at a  $V_{O_{min}}$  of 132 kts has  $\frac{dy}{dV} = 0.07$ ; at 5 kts slower,  $\frac{dy}{dV} = 0.10$ . This airframe therefore falls into the Level 2 region of the present specification. Pilot rating of the F-4J (J79 engines) is indeed Level 2 (Cooper-Harper rating equal to 4.5); pilot rating of the F-4K (Spey engines) is also Level 2 (Cooper-Harper rating equal to 6), but very near the Level 2 boundary. Thus, the F-4K has significantly degraded handling qualities with respect to the F-4J. The only difference between the aircraft is in the engine characteristics. Reference 32 concludes that the present specification does not necessarily guarantee Level 1 handling qualities for power approach.

In discussing paragraph 3.6.2, "Speed and flight path control devices", Reference 32 considers the thrust response differences between the J79 and Spey engines and concludes that the observed differences in handling qualities between the B and M models is the result of engine performance differences. It is recommended in Reference 32 that the present paragraph 3.6.2 be modified to state that "engine thrust-to-throttle characteristics shall be compatible with the airframe stability and control characteristics ... in the power approach configuration."

Similar comparisons of the F-5A and F-5E aircraft have been reported in References 33, 34 and 35. At  $V_{O_{min}} = 198$  kts the F-5A has  $\frac{dy}{dV} = -.055$  and  $\frac{dy}{dV} = -.035$  at  $V_{O_{min}} -5$ . These values are solidly within the Level 1 region of MIL-F-8785B. For the F-5E the corresponding values are  $\frac{dy}{dV} = +0.056$  and  $+0.087$  -- also Level 1, but near the boundary.

# Contrails

Although both the F-5A and F-5E satisfy the Level 1 criterion, their steady state flight path responses are opposite in sense. If  $\frac{dy}{dv}$  is a reasonable figure of merit for power approach handling qualities then it seems reasonable to assume that the F-5E would elicit different pilot comments than would the F-5A. This is not the case. Pilot comments suggest that there is no perceptible difference in power approach handling qualities, other than a slight tendency for the F-5E to touch down more firmly than the F-5A, following flare.<sup>35</sup>

Although it was not required to meet these requirements, the YF-16 was compared with the specifications of MIL-F-8785B.<sup>36</sup> At  $V_{Omin} = 133$  kts,  $\frac{dy}{dv} = 0.12$  and  $\frac{dy}{dv} = 0.178$  at  $V_{Omin} - 5$ .<sup>†</sup> These values are near the Level 2 boundary. Nevertheless, the AFFTC flying qualities evaluation<sup>37</sup> noted no difficulties in power approach flight path control (after the initial problem due to excessive pitch sensitivity was corrected with a feel system modification). Touchdowns were described as "gentle".

Cromwell and Ashkenas, in a classic study of carrier approach<sup>38</sup>, successfully predicted the pilot-selected, minimum approach airspeeds for five or seven aircraft examples. This was done under the assumption that airspeed is controlled with elevator and flight path angle with throttle. Cromwell and Ashkenas were led to conclude that pilots preferred thrust control of altitude and elevator control of speed for carrier approach despite analyses which showed that elevator control of altitude had the desirable characteristics of high bandwidth, good phugoid damping, and improved control authority.

## B. PILOT-CENTERED FLIGHT PATH CONTROL PERFORMANCE

The short-period handling quality metrics proposed in Section VI are derived from flight test data, averaged over a variety of flight control tasks. The power approach task, however, was not tested. The metrics of Section VI are proposed as necessary criteria for acceptable handling qualities for those control tasks requiring aggressive (time-constrained), precision piloted control. There are, at this writing, no data available for determination of how (or if) the proposed short-period requirements can be used for the development of power approach specifications.

A complicating factor is the necessity to rationally account for the coordination of throttle and elevator control in power approach. There are various

# Contrails

ways in which throttle may be used for power approach control. For example, throttle can be used only for airspeed regulation, with elevator used for path angle control; this converts a back-side approach into a dynamically equivalent front-side approach (insofar as the  $\gamma \rightarrow \delta e$  loop is concerned). Alternatively, throttle can be used to correct path angle error, with elevator used for speed control. The latter technique is the more likely one for the back-side approach where two compelling factors exist:

- (1) When low side flight path errors are corrected with increasing thrust, flight safety may seem to be enhanced.
- (2) Line-of-sight displays of airspeed have not been customarily used.

The first factor is a confidence-building consideration. There is a real danger of getting too slow, and settling due to faulty power management; the chances for this are reduced when the approach profile requires increasing thrust to touchdown. [There is, however, a very real chance that the high, fast approach in the middle will become a low, slow -- and dangerous -- approach near touchdown because of power mismanagement]

The second factor (lack of speed cues) inhibits the use of elevator for glide-slope control when speed cannot be closely regulated with throttle -- otherwise the pilot-aircraft system dynamics tend to be unstable.

Regardless of how throttle and elevator might be used for control of glide-slope and speed, it is believed that pitch attitude must be closely maintained with elevator. It is therefore plausible that the short-period requirements of Section VI are also necessary requirements for acceptable power approach handling qualities. This, however, may be too severe for specification purposes; it has not been demonstrated whether the control precision required for approach and landing is of the same order as that required for air combat tasks -- although this seems reasonable for the post-flare portion of the approach. Accordingly, until adequate data become available it will be assumed that:

- (1) The satisfaction of the short-period dynamic requirements of Section VI is sufficient to ensure the acceptability of front-side power approach handling qualities. These, however, may be too stringent for direct use as design specifications for the power approach condition.

# Contrails

- (2) The back-side approach requires a qualitatively different control technique than that implied by the current specification of  $\frac{dy}{dv}$ . In addition to short-period dynamic requirements, back-side operation requires a specification of flight path performance due to throttle.

The "sufficiency" of the short-period requirements means that aircraft meeting these specifications should also have acceptable handling qualities in front-side power approach. However, failure to satisfy the short-period requirements does not mean that handling qualities will be unacceptable.

Various metrics for flight path performance were examined. These were mostly derived from a comparison of the metrics previously developed for  $\theta$  and  $\dot{\theta}$  responses with equivalent metrics for  $\gamma$  and  $\dot{\gamma}$  responses to both elevators and throttle control. Fourteen aircraft were analyzed. Their stability derivatives, total available thrust, thrust increment used for thrust response calculations, engine response time ( $\tau_{\text{engine}}$ ), and thrust line inclination relative to the nominal flight path are listed in Table 11.

Engine thrust response dynamics were simulated with a piecewise linear model based on the thrust response curves of Reference 32. These are assumed to be representative of turbojet and turbofan responses. The resulting engine model consisted of a characteristic response time that was a function of thrust level. Typically, the initial thrust level for steady state power approach was estimated at 45 to 55 percent of military rated thrust (about 75 percent maximum rpm), depending on the relative cleanness of the aerodynamic configuration. Engine acceleration times were estimated from the steady state approach engine rpm range and the time from idle to military rated thrust. Figure 18 illustrates how the engine thrust was modeled. A step throttle input is assumed. The model is completely parameterized by  $\Delta\text{thrust}$  and  $\tau_{\text{engine}}$ . The straight line segments approximate the actual thrust response. Actual engine data was not available. It was believed that the thrust model used should simulate the dominant features of the propulsion system in this manner in order to construct a realistic model for power approach handling qualities assessment. The values  $\Delta\text{thrust}$  and  $\tau_{\text{engine}}$

TABLE 11. SUMMARY OF AIRCRAFT AERODYNAMIC DATA REQUIRED FOR ESTIMATION OF  $\dot{\gamma}(t)$  RESPONSE TO CONTROL

A/C	$X_u$	$X_v$	$Z_u$	$Z_w$	$Z_q$	$Z\delta_e$	$M_w$	$M_v$	$M_q$	$M\delta_e$	AThrust #	Total Thrust # (10)AVAIL	$U_0$ (ft/sec)	*** $\zeta$ rad	Mass (SLUGS)
(1) F-8	-.0601	-.035	-.265	-.426	-2.5	-13.75	-.0002	-.00486	-.338	-2.52	7,500	13,700	234.0	.03	583.2
(1) F-4B	-.0707	.0296	-.270	-.373	-2.38	-9.23	-.0006	-.0087	-.285	-1.702	11,000	20,000	226.0	.332	1036.0
(2) F-5A	-.0564	-.0609	-.276	-.508	-2.5	-24.1	0.0	-.0084	-.296	-3.16	4,300	7,050	228.0	.21	311.0
(1) A-6A	-.0724	.1134	-.388	-.618	-3.08	-22.35	0.0	-.0105	-.57	-5.52	10,000	18,600	160.2	.279	876.0
(1) RA-5C	-.0692	.0398	-.311	-.569	-4.06	-17.53	0.0	-.0038	-.248	-1.43	12,000	20,000	216.0	.174	1397.5
(1) A-3B	-.0337	.0512	-.2909	-.7085	-3.85	-8.14	0.0	-.006	-.530	-1.15	14,000	27,400	223.0	.06	1584.0
(1) F-3B	-.0003	.0575	-.213	-.5694	-6.75	-11.63	0.0	-.0016	-1.02	-1.79	17,500	35,000	213.5	-.028	2779.0
(1) C-5A	-.0274	.0496	-.174	-.2791	-4.0*	-4.81	0.0	-.0026	-.567	-.4068	110,000	164,000	177.0	.265	17081.0
(2) DC-8	-.0285	.0629	-.2506	-.6277	-4.0*	-10.19	-.001	-.0087	-.7924	-1.35	26,000	72,000	243.5	.21	5900.0
(3) NF-33A	-.0359	.0445	-.1757	-.693	-4.0*	-6.88	-.001	-.00676	-.333	-2.25	3,000	5,500	167.0	.104	385.0
(7) F-111A	-.0676	.105	-.450	-.7359	-5.856	-19.2	-.0016	-.0104	-.2045	-3.52	11,000	26,500	227.0	.209	1647.5
(6) T-2C	-.0357	.0534	-.2206	-.7683	-4.0*	-14.45	-.002	-.0168	-1.105	-5.824	3,000	5,900	183.0	.07	341.6
(5) YF-16	.0587	-.0710	-.3003	-.5823	-2.5*	-81.89	0.0	-.00788	-.602	-7.12	12,000	18,500	221.6	.227	515.5
(4) F-4M	-.0707	.0296	-.270	-.373	-2.38	-9.23	-.0006	-.0087	-.285	-1.702	12,000	24,500	226.0	.332	1036.0

SOURCE

- 1 NADC-AM-7106
- 2 STI 176-1
- 3 AFFDL-TR-70-71
- 4 AFFDL-TR-70-155
- 5 AFFTC-TR-75-15
- 6 NADC-74181-30
- 7 F2N-12-4198 (General Dynamics)
- 8 F2N-401-041 "
- 9 F2N-401-095 "
- 10 Estimated from AVTK&ST, Vol 108, No 11, 1978. Data Does Not Include A/B (static mil thrust std day, uninstalled)

Units are defined in WADC-TR-58-82

\* Estimated Data Not Available

\*\* Conditioned by knowledge of aircraft AOA (typical power approach) and percent NRI for nominal approach

\*\*\* Thrust line inclination with respect to flight path

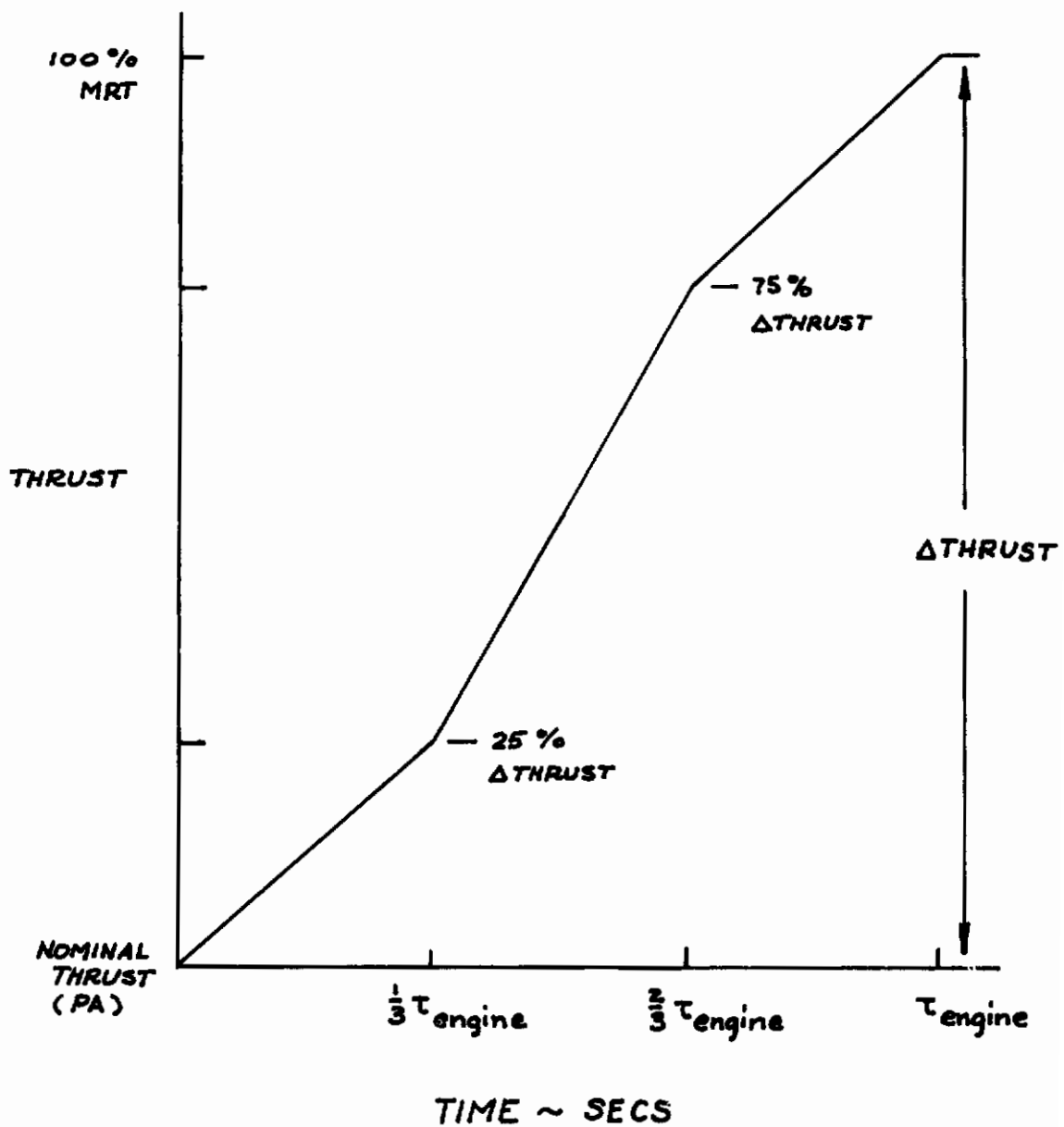

Figure 18. Engine Thrust Model for Calculation of  $\dot{\gamma}(t)$

# Contrails

listed in Table 11 were, in some cases, best-guess estimates based on knowledge -- however, qualitative -- of engine responsiveness and aerodynamic configuration.

No stability augmentation was assumed for any of the aircraft examples in Table 11 (except, of course, for the YF-16). The use of a pitch damper (available on most of the example aircraft) may result in improved flight path response to elevator, but would probably not significantly affect response to throttle input.

## The Results

The only positive result that emerged from analysis of the aircraft examples from Table 11 was an apparent correlation between front-side/back-side operation and the time required to arrest a rate of sink.

The time to arrest rate of sink,  $t_s$ , was defined to be the time from application of elevator or throttle control, to achieve a  $3^\circ$  increase in flight path angle. For a  $-3^\circ$  approach  $t_s$  corresponds to the minimum time required to establish a positive rate of climb (see figure 19).

Table 12 summarizes  $t_s$  for step elevator and step throttle inputs. The magnitude of the thrust command is equal to  $\Delta$ thrust (Table 11); propulsion dynamics are included, as previously indicated. The magnitude of the elevator input was sufficient to increase the angle of attack by a maximum of  $5^\circ$ ; this was determined for each aircraft by a separate calculation.

No conclusions are offered, based upon the data of Table 12, about the effects of elevator response properties on handling qualities. There is, however, an apparent connection between  $t_s$  and handling qualities for throttle response, but only for those aircraft that are operated on the back-side of the drag curve. The F-8C handling qualities in power approach are poor ( $t_s = 6.35$ ). The F-4B is acceptable ( $t_s = 2.92$ ) while the F-4M is poor ( $t_s = 5.90$ ). The F-111A was unacceptable in carrier approach ( $t_s = 5.39$ ) -- but acceptable for field landings ( $t_s = 1.85$  with elevator). The A-6A is acceptable ( $t_s = 3.06$ ). The RA-5C ( $t_s = 5.10$ ) and A-3B ( $t_s = 5.03$ ) are both probably marginal.



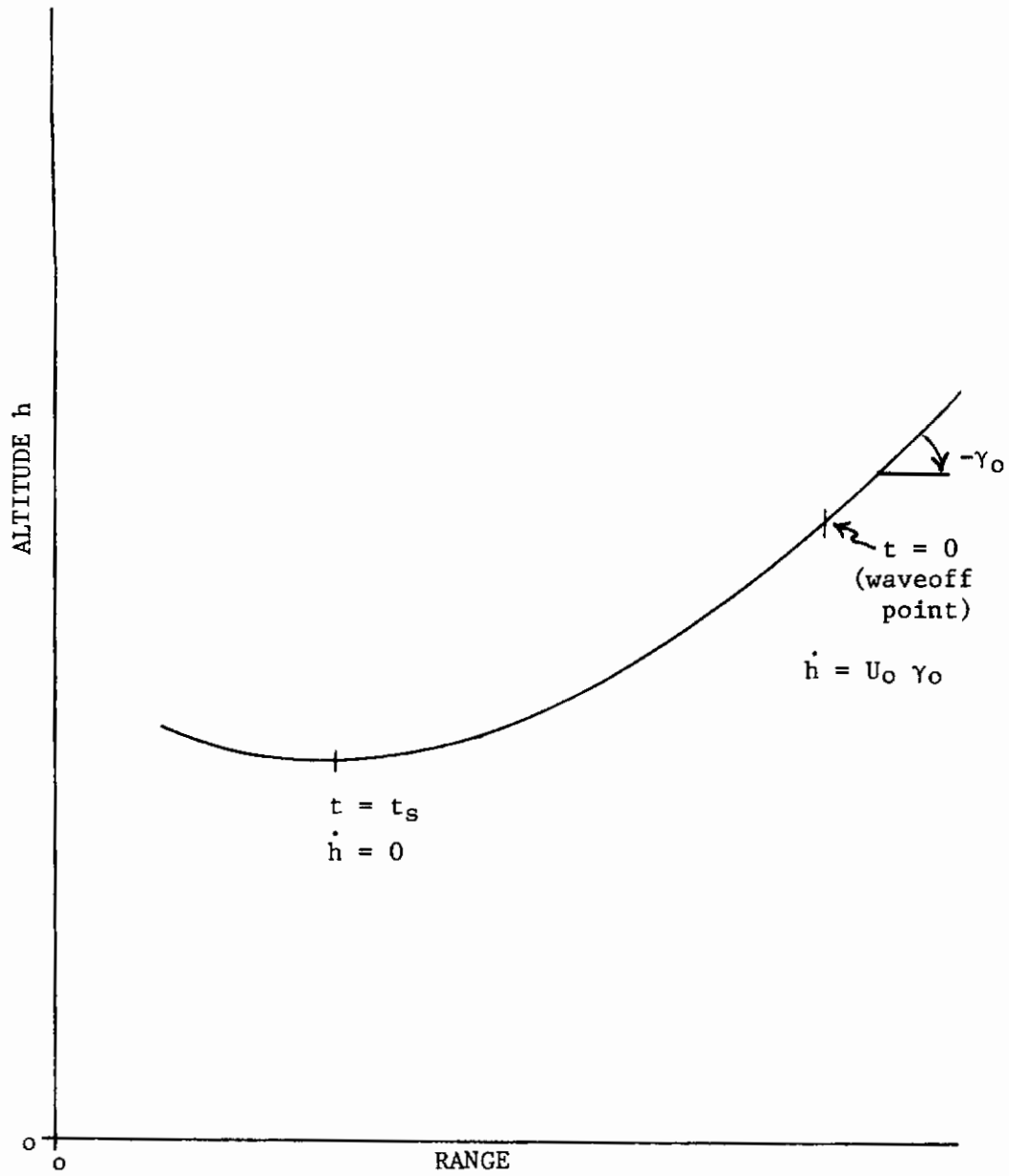

Figure 19. Definition of Rate of Sink Parameter,  $t_s$

# Contrails

TABLE 12. SUMMARY OF RESULTS:  
TIME TO ARREST RATE OF SINK  $t_s$

AIRCRAFT	$t_s$ , TIME TO ARREST RATE OF SINK	
	ELEVATOR CONTROL	THROTTLE CONTROL
F-8C	2.85	6.35
F-4B	2.92	2.92
F-5A	2.42	2.95
A-6A	2.13	3.06
RA-5C	2.71	5.10
A-3B	2.09	5.03
P-3B	2.81	5.91
C-5A	4.58	5.10
DC-8	2.09	6.83
NT-33A	2.17	5.39
F-111A	1.85	5.39
T-2C	1.64	4.38
YF-16	2.35	3.24
F-4M	2.92	5.90

## C. A PROPOSED SPECIFICATION FOR FLIGHT PATH STABILITY

For those aircraft that are operated on the front-side of the drag curve in power approach, the short-period requirements proposed in Section VI are believed to also be sufficient criteria for power approach. Available data do not support additional criteria.

For back-side aircraft the short-period requirements proposed in Section VI are possibly neither necessary nor sufficient as criteria for power approach. A requirement on time to arrest a rate of sink is proposed, in addition to any requirement that may be imposed on short-period dynamics.

Until better criteria can be developed, it is recommended that the current requirement on  $d\gamma/dV$  be retained, but only for front-side, Class II & III aircraft.

The proposed criterion for time to arrest rate of sink, applicable only to back-side operation (i.e. for those nominal power approach configurations for which  $dD/dV \leq 0$ ) for all Classes, is:

Level 1;	$t_s \leq 3.0$
Level 2;	$3.0 < t_s \leq 5.0$
Level 3;	$5.0 < t_s$

$t_s$ , in seconds, is defined in figure 19. The boundary values were selected from the results shown in Table 12.

More research is clearly needed if more definitive power approach requirements are to be developed.

+ The YF-16 data on page 141 was from (Reference 36) and was only preliminary analysis. This analysis may not truly represent the aircraft; flight data is not available.

## Section VIII

### HANDLING QUALITY REQUIREMENTS PECULIAR TO DIGITAL FLIGHT CONTROL SYSTEMS

#### A. GENERAL

There are almost no hard data available suitable for the development of empirically based handling quality specifications for DFCS. In this section, a qualitative overview of the typical DFCS is taken and some functional level requirements are proposed. These are quantified insofar as possible. The general viewpoint of the handling qualities problem is that given in previous sections of this report. The "typical" DFCS is represented by the generic control system of Figure 1.

There are only three areas of potential impact on handling qualities due to DFCS peculiarities, per se. These are:

- analog-to-digital conversion (ADC) effects,
- control law implementation effects within the FCS computer, and
- digital-to-analog conversion (DAC) effects.

Handling quality requirements for each of these three areas will be proposed in the following articles.

#### B. THE TRANSPARENCY CRITERION

It is proposed that no matter how a DFCS is mechanized the operations that are peculiar to a digital process controller--whether hardware or software oriented--must be transparent to the pilot. That is, the digital elements of the FCS must be "invisible" to him. It is proposed that a general statement to this effect be included in future revisions to MIL-F-8785B.

## C. CONTROL LAW IMPLEMENTATION AND LOW FREQUENCY LIMITS ON ALLOWABLE FRAME RATE

It isn't entirely possible (or necessary) to forecast how analog information defining the aircraft or target states might be used by one or several central, digital processors which constitute the major hardware peculiar to the DFCS. We assume that this information will be processed via software to define control commands and display features.

The digital process mechanics, together with the mechanics involved in ADC and DAC, result in a transform model between commanded control signals and analog sensor outputs which supply the ADC. Whether one visualizes this model in terms of Z-transform, W-transform, etc. is entirely irrelevant. We prefer to view it as just a computer program, in essence, with some sample and hold effects contributed on either side. Due to the effects of digital process mechanics, per se, these transform dynamics are not necessarily what the FCS designer might want. Even simple numerical integration can alter system dynamics;<sup>8</sup> this may degrade numerical process stability in severe cases. In very simple cases, the effect of using a digital computer to implement a control law (pitch SAS, for example) could be represented as a time delay of magnitude equal, say, to one-half that of the DFCS cycle time.

The details of how a DFCS is mechanized really aren't germane to the functional specification of handling quality requirements. The requirements proposed in the two previous sections apply regardless of whether a DFCS is used or not.

Thus, when a DFCS is used, the requirements on pitch dynamics (Equations 12 and 13) are applicable. These requirements will have a definite impact on how the DFCS might be mechanized. As an example, consider an airframe for which  $\frac{\theta}{\delta_e} j\omega_c = -100^\circ$ , with actuator and servo valve lag of  $-15^\circ$  at  $\omega_c$ ; according to (12), the maximum permissible phase lag due to the digital computer, the ADC and DAC is  $10^\circ$ . If the digital system elements may be treated as a time delay of  $T/2$  seconds ( $T$  = frame period of DFCS for

attitude control loop), then the absolute maximum value of T permitted by the Level 1 criterion of (12) is

$$T_{\max} = \frac{2 \times 10}{57.3\omega_c}$$

When  $\omega_c = 5$  radian/second,  $T_{\max} \cong 1/15$  second.

It is expected that the implications to handling qualities of low frequency digital sampling (i.e., low frame rate) are embodied in the pitch attitude requirements proposed in Section VI.

#### D. HIGH FREQUENCY LIMIT ON ALLOWABLE FRAME RATE

A popular notion is that with the digital systems hardware either now available or soon to be available, the operation of a DFCS can be made to look just like an analog system merely by clocking the system at very high frame rates (several hundred or thousand Hertz). This ignores the possible adverse effects of ADC on the quality of system response and performance.

An ADC converts an analog signal (a voltage) into a digital word. This word consists of a fixed number of bits (e.g., 8, 12, or 16). Each binary digit (bit) represents a certain fraction of the maximum analog signal value or of the analog signal range.

If the ADC rate is so large that the separation between successive signal samples sent to the central processor is less than the resolution provided by one bit in the ADC output, then the digital processor will not recognize that a change has occurred in the analog signal. It is impossible to say what, in general, the specific effect of sampling at rates great enough to exceed the ADC resolution limits might be. However, it is intuitively plausible that when the control law implementation requires table look-ups, numerical integration, numerical differentiation, interpolation, or any process based on the use of successive samples for the estimation of control commands, the overall effect will be similar to the injection of

# Contrails

noise into a comparable analog process. This could result in degraded FCS performance and have a potentially adverse effect on handling qualities.

We propose, therefore, the following specification as an upper limit on allowable frame rate:

$$f < \frac{x_o \omega_c}{10R/2^n} \quad (19)$$

where

$$f = \frac{1}{T}, \text{ Hertz}$$

T = frame (sample) period of CPU operation, seconds

$\omega_c$  = crossover frequency for pitch attitude control;  
defined by Equation 10, radian/second.

R = range of  $x(t)$  used for scaling of the ADC;

$$\text{range} \triangleq \left| X_{\max} - X_{\min} \right|$$

n = wordlength, in number of bits, of the ADC for  $x(t)$

x = any aircraft state variable input to the ADC; in general,  
 $x = q, \theta, a_{z_p}$  or  $\alpha$

$x_o$  = average amplitude of  $x(t)$  perturbations from the average value of  $x(t)$  in a prescribed flight mode and FCS configuration. It is recommended that the following values be used for specification purposes:

$$x_o = 1 \text{ degree/second for } q(t),$$

$$x_o = 3 \text{ degrees for } \theta(t),$$

$$X_o = 0.25 \text{ g for } a_{z_p}(t), \text{ and}$$

$$X_o = 3 \text{ degrees for } \alpha(t)$$

# Contrails

$X_{\max}$  and  $X_{\min}$  are the maximum and minimum values of  $x(t)$  that are used to establish the range of the ADC.

As an example, assume  $x(t) = q(t)$ . Assume the range of  $q(t)$  to be from -180 to 180 degrees/second; i.e.,  $R = 360$ . The following table of results are then obtained from (19):

$\omega_c$	n	f
3	8	0.2
	12	3.4
	16	54.6
4	8	.3
	12	4.6
	16	72.8

For this example, it is clear that a 16 bit ADC is required and that the maximum frame rate is surprisingly low. If it was desired that  $f = 1000$  Hz, with  $\omega_c = 4$ , (19) would require that  $n = 20$  bits for this example. If  $n = 32$  bits, the sample frequency could be nearly 5 MHz.

The development of the criterion expressed in (19) is straightforward. If we can assume that

$$x(t) \cong X_o \sin \omega_c t$$

then

$$\frac{dx}{dt} \max = X_o \omega_c$$



# Contrails

In one frame period  $\Delta X_{\max} = X_o \omega_c T$ ; this value must be greater than the ADC resolution, which is  $R/2^n$ . Thus,

$$R/2^n < X_o \omega_c T$$

or

$$\frac{1}{T} = f < \frac{X_o \omega_c}{R/2^n}$$

But to maintain numerical process accuracy, it is advisable that the separation between  $\Delta X_{\max}$  and  $R/2^n$  not be too small; otherwise many intersample changes in  $x(t)$  will go undetected by the sampler. The factor of 10 is introduced for that reason. The result is Equation 19.

The crossover frequency  $\omega_c$  was selected as the criterion frequency based on prior discussions in Section VI.

## E. CONTROL ROUGHNESS

Central processor control output commands to the digital-to-analog converter are, of course, discrete and occur once each frame period  $T$ . The spectral properties of this converted digital command to control surface actuators will not be exactly like those of a continuous analog controller. In general, the DAC output will contain "glitches" representing discrete jumps in commanded control from frame-to-frame. These glitches, if unfiltered, can result in aircraft response "harshness" that may result in increased levels of  $\sigma_q$  (and therefore degraded pilot opinion rating) with corresponding degradation of control precision and tracking performance.

A qualitative statement should be included in MIL-F-8785B to the effect that handling qualities degradation due to control roughness is not permissible for Level 1.

# Contrails

A quantitative requirement, and an implied validation procedure, is given, as follows:

Assume that the central processor commands  $\delta_e(t)$  to equal a sinusoid; i.e.,

$$\delta_e(t_i) = \delta_{e_0} \sin \omega_c t_i, \quad i = 1, 2, \dots$$

The digital signal  $\delta_e t_i$  is to be converted by the DAC. The DAC output  $\delta_{e_c}(t)$  will be a reconstruction of the commanded sine wave. However, it will contain power at frequencies other than  $\omega_c$ ; the actual power spectral density will be a function of the DAC hardware. It is desired that the responses  $q(t)$  and  $a_{z_p}(t)$  due to differences between  $\delta_e(t)$  and  $\delta_{e_c}(t)$  be sufficiently small and not apparent to the pilot. [If control roughness is apparent at frequencies less than about  $2\omega_c$ , the pilot will very likely attempt to track the roughness, in effect, and the tracking precision and handling qualities may be sharply degraded.] To ensure that this is obtained, require that

$$\begin{aligned} \left| \frac{q}{\delta_e}(j\omega_c) \right| \Delta\delta_e &\leq .001 \text{ radian/second} \\ \left| \frac{a_{z_p}}{\delta_e}(j\omega_c) \right| \Delta\delta_e &\leq .01g \end{aligned} \tag{20}$$

where  $\Delta\delta_e$  is defined to be the maximum difference between  $\delta_{e_c}(t)$  and its fundamental  $\delta_e(t)$ :

$$\Delta\delta_e = \max \left| \delta_{e_c}(t) - \delta_e(t) \right| \tag{21}$$

The values chosen for magnitude tolerances, i.e., .001 radian/second and .01g, are believed to be reasonable approximations to the respective perception thresholds of these piloting cues. The prescriptions of Equation (20)

# Contrails

therefore require that the control signal's "noise" component be sufficiently small that no perceptible effect is felt by the pilot. The criterion frequency  $\omega_c$  was selected because of its general importance as a handling qualities parameter.

The fundamental will differ in phase from  $\delta_e(t)$  by an amount  $\phi$ ; it may also differ in amplitude. Since the criterion signal  $\delta_e(t)$  is arbitrary to a degree, there is no point in comparing  $\delta_{e_c}(t)$  with  $\delta_e(t)$  or with  $\delta_e(t)$  shifted into phase with  $\delta_{e_c}(t)$  and its fundamental; that is, the harmonics of  $\delta_{e_c}(t)$  are the problem and we treat them, directly.

The magnitude,  $a$ , of the DAC output fundamental component  $\delta_o$  must be sufficient to yield

$$(1) \quad \left| \frac{g}{\delta_e}(j\omega_c) \right| a \geq 1 \text{ degree/second, and}$$

$$(2) \quad \left| \frac{a_z p}{\delta_e}(j\omega_c) \right| a \geq 0.25 \text{ g}$$

The requirements (20) could be met in one of two ways. A fairly crude DAC could be used with large frame rate  $f$ . Small frame rates could be used with a more sophisticated DAC technique (CPU post-filtering, greater word-length, slower sample and hold rather than zeroth order, etc.).

According to these criteria, phase shifts introduced by the DAC are tolerable, although they cannot be so large that the criteria of (12) and (14) are violated. The criteria (20) specify how much discontinuity can be tolerated at the DAC output before handling qualities and control precision are degraded.

The requirement (19) proposed as an upper limit on frame rate may, at times, come into conflict with (20). The latter criteria tend to increase

# Contrails

the required frame rate. When  $T$  is minimum to satisfy (19) yet (20) are still violated, one solution is to decrease  $\Delta\delta_e$ . This can be done with an analog post-filter at the DAC output or, perhaps, with digital post-filtering at the DAC input. When this is done, however, the filtering should be no more than required to meet the criteria (20); otherwise the phase criteria on  $\theta$  and  $a_{z_p}$  responses may be violated. As a general rule, filtering operations introduced for the purpose of signal smoothing must be carefully executed if handling qualities are to remain satisfactory and problems such as PIO avoided.

## APPENDIX

RECOMMENDED REVISIONS TO MIL-F-8785B:  
LONGITUDINAL PILOT-INDUCED OSCILLATIONSRalph H. Smith  
Systems Research Laboratories, Inc.11 May 1977  
Contract F33615-77-C-3011

## INTRODUCTION

Recent work (Reference 2) done under sponsorship of the AFFDL has resulted in the formulation of a theory for longitudinal, pilot-induced oscillation (PIO). This theory has been applied to the study of past occurrences of PIO for which suitable documentation exists; it has been shown to explain how PIO is initiated and how the phenomenon is dependent upon air-frame and control system parameters. The theory is predictive; it appears to enable the forecasting of PIO during design.

From the PIO theory of Reference 2 it is intended to develop acceptance criteria for aircraft procurement that can be used to minimize the possibility that a PIO-susceptible aircraft design will reach the flight test phase of development.

## PHILOSOPHY

It is assumed in this recommended revision that the essential purpose of MIL-F-8785B is to serve as a document for aircraft procurement. MIL-F-8785B should also assist the aircraft design process by providing specifications for parameter selection to enable the qualitative requirements of MIL-F-8785B to be satisfied, insofar as this is possible. It is also assumed that each specification paragraph will be documented as a guide to systems design. This back-up documentation is assumed to be advisory, only, and not contractually binding.

# Contrails

This recommended revision represents an attempt to address the realities of present and probable near-term future aircraft design approaches. Aircraft are not designed entirely on paper prior to their manufacture; the flight simulator has become an important tool for system design, test and evaluation. It is possible to make analytical predictions of aircraft handling qualities and pilot-vehicle system dynamics. Such assessments could play a vital role in the earliest stages of aircraft conceptual and preliminary design; however, the quantification of an aircraft or flight control system design ultimately requires pilot-in-the-loop test and evaluation. This recommended revision is submitted based on the premise that both analysis and simulation will be used in a coordinated, sequential, and (possibly) iterative fashion to predict and experimentally assess the implications to handling qualities of airframe or control system design trade-offs.

There appears to be a general misconception about pilot-vehicle systems analysis, its use for the identification of suitable handling quality parameters, and the use of analytical prediction methods for the derivation of specifications for aircraft or control system design. The philosophy on which the present recommendation is based is that the product desired of such analyses must be clearly understood; otherwise the potential benefits of pilot-vehicle systems analysis methods can never be realized. After all, these methods have been available for about two decades; they were originally developed to enable the prediction and specification of handling qualities, but to this date they have had very little impact on either handling qualities prediction or on MIL-F-8785B. The basic reason for this failure appears to be the belief by many that these analysis methods can replace MIL-F-8785B. They cannot. MIL-F-8785B is a buyer's guide, whereas the pilot-vehicle analysis methods can be (and have been) used to develop design methods. The specifications for design acceptance and methods for designing to specification compliance are two distinct problem areas and must be recognized as such.

The recommended revision to MIL-F-8785B for longitudinal PIO is the secondary product of systematic application of pilot-vehicle control theory. The product of this 6.1 research was a theory for pilot-vehicle system dynamics in the incipient and fully developed PIO. This theory is useful for

# Contrails

the prediction of PIO-prone aircraft dynamics (classical or nonclassical); it is, in itself, useless as a specification to preclude PIO. The conversion of the theory into a suitable specification for aircraft-control system design was a task of near-equal difficulty to that of developing the original theory.

Pitch attitude dynamics were shown to be a central factor in the development of PIO. One difficulty in preparing a specification for PIO was to ensure compatibility with the present short-period dynamic requirements of MIL-F-8785B. Another problem was to integrate the overall dynamic requirements with those of the artificial feel system and any control system nonlinearities included. These are relatively easy considerations to make in a theoretical description of PIO; they are troublesome in the development of a specification.

The approach taken in the development of the PIO specification revision was to

- (1) Concentrate on airframe dynamics that are not specified elsewhere in MIL-F-8785B.
- (2) Assume that the PIO specification is to apply independently of the short-period dynamic requirements of the current MIL-F-8785B (and this is validated by the PIO theory).
- (3) Strive for simplicity.
- (4) Maintain an overall character of specification that is as near to that of the present MIL-F-8785B as possible; in particular, there was to be no overt reference to controversial pilot-vehicle systems analysis methods.
- (5) Not propose any specification item that could not be justified on an empirical basis.
- (6) Ultimately, take MIL-F-8785B to be a buyer's guide (not a design guide), retain the present qualitative statement that PIO shall not be allowed, and assume that the theoretical description of PIO (Reference 2) will be cited by MIL-F-8785B as a design guide for meeting the specification requirements.

# Contrails

In the main, the proposed revision meets these goals.

Finally, it was intended that the proposed revisions address the requirements of the flight test community and the SPO engineers who must test, evaluate and certify flight safety and specification compliance. The proposed specification statements are believed to lend themselves to flight testability. Possibly one of the most important impacts these revisions, if adopted, would have is on the flight test identification of pitch-sensitive versus PIO-prone aircraft configurations. This is a matter of no little importance in the procurement process.

It should be noted that these proposed requirements are unrestricted in their applicability. They are equally valid for classical and nonclassical aircraft control system dynamics.

MIL-F-8785B: paragraph:

3.2.2.3 Longitudinal pilot-induced oscillations. There shall be no tendency for pilot-induced oscillations, that is, sustained or uncontrollable oscillations resulting from the efforts of the pilot to control the airplane.

Proposed revision: None

Rationale for nonrevision: This qualitative requirement should be retained in view of uncertainties in the state of the art of flight control system design. PIO is a complex problem. This paragraph is an implicit recognition of its complexity and an admission that no detailed specification can, at this time, be a guarantee against building a PIO-prone airframe-control system.

MIL-F-8785B paragraph:

3.2.2.3.1 Transient control forces. The peak elevator-control forces developed during abrupt maneuvers shall not be objectionably light, and the buildup of control force during the maneuver entry shall lead the buildup of normal acceleration. Specifically, the following requirement shall be met when the elevator control is pumped sinusoidally. For all input frequencies, the ratio of the peak force amplitude to the peak normal load factor



amplitude at the c.g. measured from the steady oscillation, shall be greater than:

Center-Stick Controllers -----	3.0 pounds per g
Wheel Controllers -----	6.0 pounds per g

### Proposed revisions

3.2.2.3.1 Control System Dynamics. The following requirements shall be met when the elevator is pumped sinusoidally for all amplitudes within the structural limits of the airframe and at frequencies  $1 \leq \omega \leq 10$  radian/second.

3.2.2.3.1.1 Control Feel. The deflection of the pilot's control must lag the control force throughout the indicated frequency range (rigid control devices are excluded from this requirement). In addition, the peak elevator control forces developed during abrupt maneuvers shall not be objectionably light, and the buildup of control force during the maneuver entry shall lead the buildup of normal acceleration.

3.2.2.3.1.3 Control System Phase Lag: Elevator surface deflection  $\delta_e$  must not lag the pilot's control force  $F_s$  by an excessive amount. In addition, the total phase angle by which normal acceleration  $a_{z_p}$ , measured at the pilot's location, lags the pilot's control force at a criterion frequency  $\omega_R$  must be less in magnitude than  $180-14.3\omega_R$  degrees, where  $\omega_R$  is in radian/second. That is

$$\left| \angle \frac{\delta_e}{F_s}(j\omega_R) + \angle \frac{a_{z_p}}{\delta_e}(j\omega_R) \right| < 180-14.3\omega_R \text{ degrees}$$

The criterion frequency  $\omega_R$  is defined to be any frequency within the range  $1 \leq \omega_R \leq 10$  radian/second at which lightly damped (resonant) oscillations in pitch attitude can result from turbulence inputs or from piloting control of the aircraft when used in the intended, operational manner. This requirement may be waived at the discretion of the procuring activity for those flight conditions for which

$$\left| \frac{a_z}{\dot{\theta}} (j\omega_R) \right| < .01 \text{ g/deg/sec}$$

3.2.2.3.2 Stick-Free Short-Period Dynamics. The pitch attitude response dynamics of the airframe plus control system,  $\theta/F_s(j\omega)$ , shall not change abruptly with the motion amplitudes of pitch, pitch rate, or normal acceleration unless it can be shown that this will not result in a pilot-induced oscillation.

Rationale for Revision:

(a) The requirements of the current paragraph 3.2.2.3.1 are still considered to be valid. However, in view of Reference 1, new requirements should be imposed on the control system and a new, qualitative requirement should be initiated dealing with stick-free, short-period dynamics. It is also more systematic to further discriminate among the three features of control system dynamics related to load factor response, control feel characteristics, and control system phase lag; this provides a close conceptual tie with the past requirements (which are retained more or less intact) and provides a convenient mechanism for introducing the new PIO requirements suggested by the theory of Reference 2.

(b) It is presumed that satisfaction of the requirement cited in the proposed paragraph 3.2.2.3.1 will be certified by the System Program Office or the Air Force Flight Test Center in any manner that is convenient to them. In fact, sinusoidal control need not--and probably would not--be used; a more sophisticated test procedure could be easily devised using modern signal analysis concepts and methods. However, the intent of the requirement is made clear by issuing the specifications in the form shown; it is unambiguous. The requirement that these specifications be met for all practical control amplitudes is new; its purpose is to ensure that effects of amplitude-dependent control or aerodynamic nonlinearities are adequately considered in the assessment and acceptance of an aircraft's handling qualities. The requirement that the control system specifications be satisfied over the frequency range of one to ten radian per second is an attempt to avoid overspecification of control dynamic requirements; for manual control, it is sufficient that only this restricted frequency range be considered.

## Contrails

(c) Proposed paragraph 3.2.2.3.1.1 is very nearly the same as the original requirement on transient control forces (paragraph 3.2.2.3.1). It differs in that the load factor is now referenced to the pilot's location, rather than the cg; generally, this is an insignificant difference. It does lend explicit recognition to the fact that the pilot-centered motion cues are those that are important to handling qualities. Also, for some combinations of short-period frequency, control location and distance of the pilot from the cg the effect is significant. In general, it appears that the formulation of the PIO requirements in terms of normal acceleration on the pilot tends to provide a small additional margin of latitude to the control system designer. Paragraph 3.2.2.3.1.1 also specifies that side-stick controller force characteristics be treated the same as center-stick. Data do not appear to exist to entirely validate this requirement; it seems reasonable to expect that it will be approximately as valid as the current specification for center-sticks since the same neuromuscular system is involved in both. Research is needed in this area. However, the side-stick controller requirements are not addressed by the current MIL-F-8785B; it is believed that quantitative specifications are important and the proposed paragraph attempts to address this requirement.

(d) The requirement proposed in paragraph 3.2.2.4.2 that the pilot's control deflection always lag the control force cannot entirely be justified on empirical grounds; the data do not exist. This requirement, alone, might have eliminated the longitudinal PIO experienced with the A4D-2 and the T-38A. CALSPAN (Reference 42) proposed the same requirement for substantially the same reasons; their proposed paragraph was 3.2.2.3 (page 38 of Reference 42). Although this requirement is partly intuitive, it appears to be consistent with what little is known about interactions between the neuromuscular system, the feel system and human subjective response. There is some evidence (e.g., Reference 43) to indicate that decreasing average stick force levels will result in increased pilot phase lag; by the PIO theory of Reference 2, this would promote PIO in a pilot-vehicle system that had a tendency to develop pitch loop resonance. It is probably true in general that the average stick force level will decrease when stick deflection tends to lead stick force. Also, the violation of this specification would be

# Contrails

prima facie evidence of probable violation of paragraphs 3.2.2.3.1.1 and 3.2.2.3.1.2.

(e) The rationale on which the proposed specification of paragraph 3.2.2.3.1.3 is based is fully explained in Reference 2. The PIO theory of Reference 2 postulates that if the pitch loop is resonant at frequency  $\omega_R$ , then the pilot may at some time (which cannot necessarily be predicted) attempt to control normal acceleration  $a_{z_p}$  to the exclusion or near exclusion of  $\theta$ . If that happens, then the violation of the phase criterion of 3.2.2.3.1.3 implies that the acceleration loop will be dynamically unstable and that a PIO will be initiated. This paragraph provides the flight control system engineer with a quantitative criterion for required minimum feel and control system dynamic performance. The amplitude criterion of this paragraph is proposed as a quantitative guide for preliminary identification in the design process (airframe or flight control system) of those flight conditions for which longitudinal PIO is probably not a realistic possibility. More data should be collected from in-flight simulation to establish the validity of this response ratio; the number selected, .01 g/deg/sec, conforms with past cases of longitudinal PIO (Reference 2). The frequency  $\omega_R$  is, in disguise, a closed-loop, pilot-vehicle parameter. Fortunately, it is also a very physical parameter (pitch loop resonant frequency) that is readily understood and accepted. No method is given in the proposed specification for its selection; methods for doing so are contained in Reference 2. The frequency  $\omega_R$  can be readily identified from simulation or from flight test; it would probably be an easy matter for SPO engineers to ascertain compliance with 3.2.2.3.1.3 without relying on pilot-vehicle analysis methods. Analytical estimates can, and should, be made by the airframe manufacturer as part of the design evolution.

(f) Paragraph 3.2.2.3.2 is a qualitative requirement included to eliminate PIO, PIO tendencies, or general handling quality deficiencies resulting from sudden changes in aircraft dynamic response to stick force control. This can occur due to bobweights, coupled with static friction, or due to saturation of elements within the automatic control system. PIO has been initiated due to these reasons in the cases of the T-38A, the A4D-2, and the YF-12.

# Contrails

## REFERENCES

1. Ralph H. Smith, "A Theory for Handling Qualities With Applications to MIL-F-8785B," AFFDL-TR-75-119, October 1976.
2. Ralph H. Smith, "A Theory for Longitudinal Short-period Pilot Induced Oscillations," AFFDL-TR-77-57, June 1977.
3. Duane McRuer, Dunstan Graham, Ezra Krendel, and William Reisner, Jr., "Human Pilot Dynamics in Compensatory Systems: Theory, Models, and Experiments with Controlled Element and Forcing Function Variations," AFFDL-TR-65-15, July 1965.
4. Thomas R. Twisdale and David L. Franklin, "Tracking Test Techniques for Handling Qualities Evaluation," AFFTC-TD-75-1, May 1975.
5. Dante A. DiFranco, "In-Flight Investigation of the Effects of Higher-Order Control System Dynamics on Longitudinal Handling Qualities," AFFDL-TR-68-90, August 1968.
6. T. Peter Neal and Rogers E. Smith, "An In-Flight Investigation to Develop Control System Design Criteria for Fighter Airplanes," Vols. I and II, AFFDL-TR-70-74, December 1970.
7. John D. Arnold, "An Improved Method of Predicting Aircraft Longitudinal Handling Qualities Based on the Minimum Pilot Rating Concept," MSE Thesis GGC/MA/73-1, AFIT, June 1973.
8. G. A. Bekey and W. J. Karplus, Hybrid Computation, John Wiley & Sons, Inc., 1968.
9. R. H. Smith, "A Unified Theory for Pilot Opinion Rating," Twelfth Annual Conference on Manual Control, NASA TM X-73170, pps. 542-558, May 1976.
10. E. D. Onstott and W. H. Faulkner, "Prediction, Evaluation, and Specification of Closed-Loop and Multiaxis Flying Qualities," AFFDL-TR-78-3, February 1978.
11. R. A. Hess, "A Dual-Loop Model of the Human Controller," to be published in the AIAA Journal of Guidance and Control, 1978.
12. Ronald A. Hess, "A Rationale for Human Operator Pulsive Control Behavior," Fourteenth Annual Conference on Manual Control, NASA TM X- , to be published, 1978.
13. R. H. Smith, "A Pilot Model for Carrier Approach and Landing," informal presentation, Eighth Annual Conference on Manual Control, May 17-19, 1972.

# Contrails

14. Ralph H. Smith and Mark E. Reigle, "Toward a Pilot Model for Carrier Approach," unpublished technical report, U. S. Naval Air Development Center, Warminster, PA, 1971.
15. H. N. Tobie, E. M. Elliott, and L. G. Malcom, "A New Longitudinal Handling Qualities Criterion," NAECON, Dayton, OH, 16-18 May 1966.
16. Charles R. Abrams, "A Performance Index for Response Evaluation of Highly Augmented Aircraft," NADC-AM-7103, Naval Air Development Center, PA, 12 October 1971.
17. W. Bihrl, Jr., "A Handling Qualities Theory for Precise Flight Path Control," AFFDL-TR-65-198, June 1966.
18. R. V. Brulle and D. C. Anderson, "Design Methods for Specifying Handling Qualities for Control Configured Vehicles," Vol. I, Technical Discussion, AFFDL-TR-73-142, Vol. I, November 1973.
19. R. O. Anderson, "A New Approach to the Specification and Evaluation of Flying Qualities," AFFDL-TR-69-120, May 1970.
20. Charles R. Chalk, et al., "Revisions to MIL-F-8785B (ASG) Proposed by Cornell Aeronautical Laboratory Under Contract F33615-7]-C-1254," AFFDL-TR-72-41, April 1973.
21. Anon., "Proposals for Revising MIL-F-8785B 'Flying Qualities of Piloted Aircraft,'" 2 volumes, AFFDL-FGC-Working Paper, revised February 1978.
22. Antoine F. Courismault, "Comparison of Various Short-Period Flying Qualities Criteria," AFFDL-FGC-TM-75-8, December 1974.
23. R. V. Brulle and W. A. Moran, "Dynamic Flying Qualities Criteria Evaluation," AFFDL-TR-74-142, October 1974.
24. J. Hodgkinson, W. J. LaManna and J. L. Heyde, "Handling Qualities of Aircraft With Stability and Control Augmentation Systems--A Fundamental Approach," The Aeronautical Journal of the Royal Aeronautical Society, February 1976, pps. 75, 81.
25. Informal Communication from Henry Jex to Ralph Smith, 1970.
26. John D. McDonnell, "Pilot Rating Techniques for the Estimation and Evaluation of Handling Qualities," AFFDL-TR-68-76, December 1968.
27. Dunstan Graham and Duane McRuer, Analysis of Nonlinear Control Systems, Wiley, 1961.

# Contrails

28. Robert Bateman, "The ABC Method of Heads-Up Flying," Advanced Display Symposium, USAF Avionics Laboratory, Wright-Patterson AFB, March 1978 (undocumented).
29. E. D. Onstott, "Multi-Axis Pilot-Vehicle Dynamics," Proceedings of the Tenth Annual Conference on Manual Control, AFIT/AFFDL, April 1974.
30. Rodrigo J. Huete, "F/TF-15A Pilot Induced Oscillation Evaluation," AFFTC-TR-77-19, September 1977.
31. C. R. Chalk, T. P. Neal, T. M. Harris, F. E. Pritchard, and R. J. Woodcock, R. J. Woodcock, "Background Information and User Guide for MIL-F-8785B (ASG) 'Military Specification-Flying Qualities of Piloted Airplanes,'" AFFDL-TR-69-72, August 1969.
32. C. C. Brady, J. Hodgkinson, "Validation of the Flying Qualities Requirements of MIL-F-008785A (USAF)," AFFDL-TR-70-115, January 1971.
33. R. N. Kandalaft, "Validation of the Flying Qualities Requirements of MIL-F-8785B (ASG)," AFFDL-TR-71-134, September 1971.
34. Anonymous, "F-5E Flying Qualities," Northrop Corporation NOR-74-39, February 1975.
35. R. H. Springer and R. W. Ryan, "F-5F Performance and Flying Qualities Evaluation," AFFTC-TR-76-12, April 1976.
36. Anonymous, "YF-16 Flying Qualities," General Dynamics FZM-401-095, date unknown.
37. J. A. Eggers, W. F. Bryant, "Flying Qualities Evaluation of the YF-16 Prototype Lightweight Fighter," AFFTC-TR-75-15, July 1975.
38. C. H. Cromwell and I. L. Ashkenas, "A Systems Analysis of Longitudinal Piloted Control in Carrier Approach," Systems Technology, Inc., TR-NO-124-1, June 1962.
39. R. H. Smith, "LSO-Pilot Interviews on Carrier Approach," U. S. Naval Air Development Center, Warminster, PA, TM No. AM-TM-1681, May 1973.
40. R. H. Smith, "The Landing Signal Officer: A Preliminary Dynamic Model for Analyses of System Dynamics," Naval Air Development Center, Report No. NADC-72078-VT, 23 April 1973.
41. Slingerland and Graylow, "Flight Test Evaluations of the Direct Lift Control F-8 Aircraft," Princeton Conference on Flying Qualities, Princeton University, 1965.
42. Charles R. Chalk, et al., "Revisions to MIL-F-8785B (ASG) Proposed by Cornell Aeronautical Laboratory Under Contract F33615-71-C-1254," AFFDL-TR-72-41, April 1973.

# Contrails

43. R. E. Magdaleno and D. T. McRuer, "Experimental Validation and Analytical Elaboration for Models of the Pilot's Neuromuscular System in Tracking Tasks," NASA CR-1757, April 1971.
44. R. L. Kisslinger, R. L. Berger, F. Krachmalnick, and Mike J. Wendl, "Survivable Flight Control System Interim Report No. 1, Studies, Analyses and Approach," AFFDL-TR-71-20, Supplement 1, May 1971.
45. James D. Dillow and Douglas G. Picha, "Application of the Optimal Pilot Model to the Analysis of Aircraft Handling Qualities," Air Force Institute of Technology, AFIT-TR-75-4, Wright-Patterson AFB, Ohio, August 1975.
46. J. D. Etheridge and C. E. Mattlage, "Direct Lift Control as a Landing Approach Aid in the F-8C Airplane" Vought Report 2-53310/4R-175, December 1964.