

**UNCLASSIFIED**

SECURITY CLASSIFICATION OF THIS PAGE (When Data Entered)

REPORT DOCUMENTATION PAGE		READ INSTRUCTIONS BEFORE COMPLETING FORM
1. REPORT NUMBER AFFDL-TR-76-135	2. GOVT ACCESSION NO.	3. RECIPIENT'S CATALOG NUMBER
4. TITLE (and Subtitle)  VUILLEUMIER COOLER WEAR RATE TEST PROGRAM		5. TYPE OF REPORT & PERIOD COVERED First Interim Report June 1975 - August 1976
		6. PERFORMING ORG. REPORT NUMBER P76-407
7. AUTHOR(s) T. Ohara K. G. Moore M. N. Gardos		8. CONTRACT OR GRANT NUMBER(s)  F33615-75-C-3117
		10. PROGRAM ELEMENT, PROJECT, TASK AREA & WORK UNIT NUMBERS  P.E. 63428F Project 2126 W.U. 21260308
9. PERFORMING ORGANIZATION NAME AND ADDRESS  Hughes Aircraft Company Culver City, California		12. REPORT DATE  December 1976
		13. NUMBER OF PAGES  181
11. CONTROLLING OFFICE NAME AND ADDRESS Air Force Flight Dynamics Laboratory Wright-Patterson Air Force Base, Ohio 45433		15. SECURITY CLASS. (of this report)  Unclassified
		15a. DECLASSIFICATION/DOWNGRADING SCHEDULE
14. MONITORING AGENCY NAME & ADDRESS (if different from Controlling Office)		
16. DISTRIBUTION STATEMENT (of this Report) Distribution limited to U. S. Government agencies only; for test and evaluation; statement applied December 1976. Other requests for this document must be referred to Air Force Flight Dynamics Laboratory (AFFDL/FEE), Wright- Patterson Air Force Base, Ohio 45433.		
17. DISTRIBUTION STATEMENT (of the abstract entered in Block 20, if different from Report)		
18. *SUPPLEMENTARY NOTES		
19. KEY WORDS (Continue on reverse side if necessary and identify by block number)  Vuilleumier cycle Cryogenics Refrigeration Closed cycle coolers		
20. ABSTRACT (Continue on reverse side if necessary and identify by block number)  The report describes the current status of the Vuilleumier cryogenic refriger- ator wear rate test program. The primary purpose of this program is to experimentally verify the projected long term operating capabilities of dry lubricated, Vuilleumier cycle cryogenic refrigerators and to investigate design alternatives for extending the endurance limits of the refrigerators. Pre- liminary testing has begun. Decisions on what to test and how to test have been made. The main testing work of the program is yet to be accomplished.		

DD FORM 1473 1 JAN 73 EDITION OF 1 NOV 65 IS OBSOLETE

**UNCLASSIFIED**

SECURITY CLASSIFICATION OF THIS PAGE (When Data Entered)

# *Contracts*

## FOREWORD

This document, which was prepared by members of the Cryogenics and Thermal Controls Department in the Laser and Electro-Optical Systems Laboratory of Hughes Aircraft Company in Culver City, California, is the first interim report on a test program to investigate Vuilleumier cooler wear rates. Work on this program began in June 1975 under Contract F33615-75-C-3117; this report covers the period from June 1975 to August 1976.

This program was conducted under the direction of William L. Haskin of the Air Force Flight Dynamics Laboratory (AFFDL/FEE) under Project 2126, Task 212603, "Cryo-Cooler Technology."

The contractor's report number is P76-407. This report was submitted by the authors in October 1976.

The following Hughes Aircraft Company personnel made significant contributions to the program and this report:

J. F. Skinner	Program Manager
J. B. Glode	Overall engineering responsibility
B. L. Renyer	Responsible Engineer
R. D. Doody	Conceptual/thermal design
M. L. Sawicki	Mechanical layout
T. Ohara	Test plan and overall coordination of test effort and data management
W. L. Johnson	Assembly and testing
K. G. Moore	Electronic design
D. L. DuBois	Electronic integration
J. E. Kercheval	Organization and preparation of report
M. N. Gardos	Materials consultant and wear analyst

# *Contrails*

# Contrails

## TABLE OF CONTENTS

Section		Page
I	INTRODUCTION AND SUMMARY . . . . .	1
II	VM TECHNOLOGY REVIEW . . . . .	3
	1. Review of Hot Rider Ring Technology . . . . .	3
	2. Hot Rider Ring Materials . . . . .	6
	3. Proposed Hardcoat Treatment of Cylinder Liner . . . . .	9
	4. Dynamic Seals and Riders . . . . .	11
	A. Predictability of Polymeric Seal/Rider Performance . . . . .	14
	B. Proposed Approach to Wear Equations for Cold Riders and Seals . . . . .	15
	C. Wear Prediction on the Basis of Viscoelasticity Fundamentals . . . . .	15
III	APPROACH TO WEAR TESTING . . . . .	20
	1. Wear Testing with 77°K VM Systems . . . . .	20
	2. Wear Testing with Accelerated Wear Test Module . . . . .	23
	3. Hi Cap Refrigerator Endurance Tests . . . . .	28
	4. Wear Test Criteria and Evaluation Techniques . . . . .	30
	A. Rider Rings . . . . .	32
	B. Displacer Seals . . . . .	35
	C. Bearings . . . . .	35
	D. Hot Cylinder Temperature Sensors . . . . .	37
	F. Flexure Pivots . . . . .	37
IV	DESCRIPTION OF WEAR TEST HARDWARE . . . . .	38
	1. Development of a Wear Resistant Hardcoating . . . . .	38
	A. Measuring Surface Adhesion of Alumina . . . . .	47
	B. Procedure for Ion Plating as Developed to Date . . . . .	47
	C. Rework of Ion Plated Materials . . . . .	49
	2. Refurbishment of GFE 77°K VM Coolers . . . . .	49
	3. Accelerated Wear Test Module . . . . .	52
	4. Hi Cap VM Refrigerator S/N 2 . . . . .	60
	5. Special Test Equipment . . . . .	67
	A. 77°K Test Console . . . . .	66
	B. Wear Module Test Stand . . . . .	79

## TABLE OF CONTENTS (Continued)

Section		Page
V	TEST RESULTS . . . . .	86
	1. Results with Hi Cap VM S/N 2 . . . . .	86
	2. Results with 77°K VM Coolers . . . . .	89
VI	RIDERLESS VUILLEUMIER DESIGN . . . . .	94
	1. Cooler Analysis and Design . . . . .	94
	2. Design Criteria . . . . .	94
	3. Displacer Design . . . . .	97
	4. Methods of Supporting Displacer . . . . .	98
	5. Brushless D-C Motor Study . . . . .	110
	A. Brushless D-C Motors . . . . .	112
	B. Position Sensor . . . . .	113
	C. Motor Winding . . . . .	115
	D. Motor Winding . . . . .	115
	E. Speed Control . . . . .	117
	F. Mechanical Considerations . . . . .	118
	G. Conclusion . . . . .	118
VII	CONCLUSIONS AND RECOMMENDATIONS . . . . .	120
	APPENDIX . . . . .	121
	References . . . . .	168

## LIST OF ILLUSTRATIONS

Figure		Page
1	Outline of wear rate test program . . . . .	21
2	Airborne VM refrigerator manufactured by Hughes Aircraft Company (4R18086) . . . . .	22
3	Preliminary test set-up for material selection tests (see Table 2 for definition of symbols used) . . . . .	24
4	View of accelerated life test module . . . . .	26
5	Cutaway view of VM refrigerator hot displacer area. . . . .	27
6	Wear characteristics of rider ring . . . . .	34
7	Wear characteristics of dynamic seals. . . . .	36
8	Wear ratio characteristics of bearing separator . . . . .	36
9	Aluminum foil test sleeve with sputtered $\text{Cr}_3\text{Si}_2$ (incomplete inside coverage) . . . . .	40
10	Inconel 718 test sleeve with ion-plated $\text{Al}_2\text{O}_3$ (complete inside coverage) . . . . .	41
11	Liner test specimens . . . . .	42
12	Sputtered $\text{Cr}_3\text{Si}_2$ (lot 1); carbide tip scratch . . . . .	43
13	Ion-plated $\text{Cr}_{23}\text{C}_6$ (lot 5); carbide tip scratch . . . . .	44
14	Sputtered $\text{Cr}_3\text{Si}_2$ (lot 1); steel tip scratch. . . . .	45
15	Ion-plated $\text{Cr}_{23}\text{C}_6$ (lot 5); steel tip scratch. . . . .	46
16	Cylinder (ready to be plated)(73-19400) . . . . .	48
17	77°K VM cooler refurbished for wear test program (71-7232) . . . . .	50
18	Hi Cap spaceborne VM refrigeration system (73-21547) . . . . .	53
19	Summation of wrist pin forces as a function of crank angle . . . . .	56
20	Motor torque as a function of crank angle. . . . .	56
21	Location of components on basic Hi Cap refrigerator . . . . .	61
22	Cross sectional view of refrigerator drive assembly . . . . .	62
23	Test module VM cooler rate program . . . . .	63
24	Test module VM cooler wear rate program . . . . .	64
25	Hi Cap long life VM refrigeration system for space application (72-21547). . . . .	65

## LIST OF ILLUSTRATIONS (Continued)

Figure		Page
26	77° test console . . . . .	67
27	Block diagram of test control and instrumentation system . . . . .	68
28	Sample data printout from teletype (Note: units 2 and 3 disconnected). . . . .	70
29	Flow diagram of main program and intercepts used in 77°K VM wear rate program . . . . .	71
30	Flow diagram of data input subroutine used in 77°K VM wear rate program . . . . .	72
31	Flow diagram of data output subroutine used in 77°K VM wear rate program . . . . .	73
32	Sample assembly listing . . . . .	77
33	Schematic of wear module test console . . . . .	79
34	Wear module test console (76-50429). . . . .	80
35	Sample printout from wear module teletype. . . . .	81
36	Teletype command routine . . . . .	82
37	Flow chart of wear module program . . . . .	83
38	Wear module memory map . . . . .	85
39	Results of first two-incremental test of 77°K refrigerator S/N 001 extrapolated for Hi Cap . . . . .	91
40	Envelope of CCSS refrigerator . . . . .	95
41	Internal configuration of CCSS refrigerator . . . . .	96
42	Schematic representation of magnetically supported displacer . . . . .	99
43	Schematic representation of pneumatically supported displacer . . . . .	100
44	Schematic representation of roller supported displacer . . . . .	100
45	Schematic representative of wire supported displacer . . . . .	100
46	Crosshead support . . . . .	101
47	Folded crosshead support . . . . .	103
48	Simple supported hot displacer . . . . .	105
49	Multiple linear bushing support . . . . .	108
50	Single linear bushing support . . . . .	109



LIST OF ILLUSTRATIONS (Continued)

Figure		Page
51	Three common winding configurations . . . . .	112
52	Block diagram of commutator. . . . .	113
53	Use of motor winding taps . . . . .	115
54	Recommended electrical commutation scheme. . . . .	116
55	Mechanical schematic for recommended commutation scheme. . . . .	117
56	Block diagram of motor control . . . . .	118
3-1	77°K airborne VM refrigerator (71-7232). . . . .	129
3-2	Three-stage high capacity spacecraft refrigerator (73-21547) . . . . .	129
3-3	View of accelerated life test module . . . . .	130
3-4	Cutaway view of VM refrigerator hot displacer area . . . . .	130
7-1	Hi Cap VM test positions . . . . .	146
9-1	Test schedule . . . . .	151

## LIST OF TABLES

Table		Page
1	Candidate material to be tested . . . . .	7
2	Definition of terms used in Figure 3 . . . . .	25
3	Effect of component failure (or excessive wear) on cooler performance . . . . .	31
4	Potential life limiting components, functions, and evaluation techniques . . . . .	32
5	Summary of hot displacer pressure drop and seal forces . . . . .	58
6	Test module design parameters . . . . .	58
7	Power summary for each hot cylinder . . . . .	59
8	Analysis of helium gas sample . . . . .	87
9	Hi Cap S/N 2 post-test analysis (908 hr) . . . . .	87
10	77°K VM hot rider ring test results . . . . .	91
11	Comparison of different designs to eliminate the hot rider . . . . .	111
12	Characteristics of various brushless motor schemes . .	113
13	Three phase motor excitation patterns . . . . .	114
14	Sensor output versus motor angle . . . . .	116
3-1	Acceptable limits . . . . .	133
7-1	77°K VM cooler test matrix . . . . .	144
7-2	Hi Cap VM cooler test matrix . . . . .	147
7-3	Test module test matrix . . . . .	148

## SECTION I INTRODUCTION AND SUMMARY

This interim report, which was prepared under Air Force Contract F33615-75-C-3117, discusses the current status of the Vuilleumier cooler wear rate test program. Several years ago, Hughes Aircraft Company began developing the Vuilleumier (VM) cycle cryogenic refrigerator which, because of its inherent characteristics, should be a reliable means of meeting the requirements for long operating life and maintenance free performance imposed by spaceborne applications. Also for several years, the Air Force has sponsored the development of technology for long life cryogenic refrigeration systems for spaceborne applications.

As a result of these developments there are today, multistage high capacity VM refrigerators that have demonstrated cryogenic performance. However, long operating life is yet to be demonstrated.

This interim report describes the status of the VM cooler wear rate test program for collecting data to develop the technology needed to

- Identify and eliminate critical VM refrigerator components (including hot cylinder rider rings) that limit the useful life of VM refrigerators
- Experimentally verify the projected long term operating capabilities of dry lubricated VM refrigerators

Specifically, the purpose of the wear rate program is to

- Investigate and identify new promising techniques and materials
- Empirically evaluate these new materials (and techniques when possible) by conducting an extensive test program in which existing 77°K VM refrigerators are used.
- Design, fabricate, and test an accelerated wear rate test module that is based on the design of the high capacity (Hi Cap) spacecraft VM refrigerator to further evaluate these new materials and techniques and to identify any other life limiting VM refrigerator components.

# Contrails

- Conduct a series of endurance tests of the Hi Cap VM refrigerator in order to obtain additional experimental verification and to identify the life limiting components of this refrigerator.
- Analyze and develop a preliminary design of a spacecraft type of VM refrigerator that does not need a hot cylinder rider ring.

The wear rate testing program is directed toward the type of cryogenic refrigerator shown in Figure 21 on page 61. This high capacity unit was originally designed to produce 12 watts of cooling at 75°K, 10 watts at 33°K, and 0.3 watt at 11.5°K simultaneously at the three flanges of the cold cylinder. This refrigerator is described completely in AFFDL Technical Report 75-108 dated September 1975. The life limiting components discussed in following sections of this report are used in the high capacity (Hi Cap) refrigerator.

This report consists of seven sections and an appendix and covers work performed from the start of the program, 9 June 1975 to 27 August 1976. Section 1 is the introduction and summary; Section 2 is a review of the VM cryogenic refrigerator technology concerning mechanical elements that limited refrigerator life as of the start of this program; Section 3 describes the test criteria and the approach to wear testing to be followed and includes the test plan, wear measurement technique and test equipment. Section 4 describes the test hardware and special test equipment used. Section 5 presents the test results as of 27 August 1976; Section 6 discusses the design of a riderless VM refrigerator and also includes the results of a brushless d-c motor design study. Section 7 presents the conclusions and recommendations.

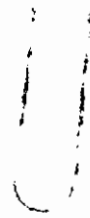

SECTION II  
VM TECHNOLOGY REVIEW

The elements that limit the life of VM refrigerators are the active mechanical and electronic components. The data accumulated during the last five years on airborne type VM refrigerators indicates the relative vulnerability of these elements. This section discusses three of the most critical elements, namely the hot rider, the dynamic seals, and the ambient riders, in addition to the treatment of cylinder liners to improve hot rider wear life.

The life of the electronic components will not be considered in this program because electronics should not be the controlling factor in the overall operating life of a VM refrigerator since space qualified high reliability solid state components are available.

1. REVIEW OF HOT RIDER RING TECHNOLOGY

At the start of the VM cooler wear rate test program, excessive wear of the VM refrigerator hot rider was considered the major limiting factor of long term refrigerator operation. The hot rider ring is used to guide the high temperature end of the hot displacer as indicated later in Figure 5. Earlier Hughes research<sup>1-4</sup> concentrated on the use of commercially available, high temperature, self-lubricating rider composites that, according to literature and data on subcontracted high temperature wear tests in 1200°F helium, exhibited the least wear on a relative scale. Those findings, which comprise the base for this program, can be summarized as follows:

- Impregnated graphite riders for the pressure-velocity (PV) range considered wear rapidly in 1200°F helium. This excessive wear eliminates graphite formulations in general as viable rider candidates for future work.
- High temperature wear experiments with test configurations other than piston ring/cylinder liner design can rate the hot rider materials on a relative scale. Such tests also yield absolute wear values such as volume or radial wear per unit time under closely controlled loads and speeds. However, differences in the degree of test parameter control; e. g.,

- oxygen content of the hot helium atmosphere,
- unit load variations as a function of geometric differences in sliding couple configurations,
- influence of characteristic misalignments, and/or
- debris removal from the wear zones

make it difficult to accurately predict the wear life of a rider from data extrapolated from test machines. Specific examples of these problems include high relative wear of hot-pressed, MoS<sub>2</sub> based, Boeing compacts (selected formulations are now commercially available from Pure Carbon Company under the Molalloy trade name) in special high temperature rub-shoe tests. The unusually high wear was attributed mainly to the high oxygen content of the poorly controlled helium test atmosphere<sup>1, 5</sup>.

Another example of these problems was the short term performance of a relatively oxygen-insensitive, fluoride-impregnated nichrome matrix composite (AmCerMet 701), in a Hi Cap refrigerator<sup>3, 4</sup>. Yet, previous to this work, preliminary examination of the test machines and tests of the bearing retainers with the AmCerMet were especially successful<sup>6, 7</sup>, enough to warrant commercial licensing of the composite<sup>8-10</sup>.

- Insufficient knowledge on the fundamental behavior of the sliding surfaces, especially where one or both frictional materials are new, can lead to erroneous conclusions and insufficient answers. When the latest results of tribological (the field of interrelationships between lubrication, friction, and wear) research were applied to AmCerMet hot riders rings, their effective life was increased. However, this increase was below that anticipated or required for most extended refrigeration applications. Hughes demonstrated that, by employing the tools of modern tribological research, fundamental knowledge can be obtained and turned to practical use. The wear life of a VM refrigerator was increased by about two orders of magnitude by applying the knowledge on the detailed wear mechanism of



AmCerMet hot riders<sup>4</sup>. Nevertheless, the 2400 hours of operation achieved with the riders represented a short term solution only.

- The few types of high temperature self-lubricating composites that are commercially available are plagued with the usual problems of quality control and reproducibility. Hughes has found it necessary to pursue an active, in-house quality control program paralleling the manufacturer's efforts.
- Extension of refrigerator life involves more than just the selection of improved rider materials. Other techniques, approaches, and designs must be considered. For example, treating the cylinder liner, possibly redesigning the rider/liner configuration, and the choice of displacer seals, riders, bearings, and flexure pivots must be investigated.

Essentially, the above summary represents a brief overview of VM hot rider technology at the start of the program. Based partially on these findings, a tentative test plan was established for the VM hot rider wear rate tests. The philosophy governing these tests is discussed in the following paragraphs.

Hughes work, along with tribophysical and chemical theory, led to favoring two basic concepts. In the first concept, a low wear rate, high temperature, self-lubricating compact rider sliding against a specially hardened Inconel 718 (or other desirable alloy) cylinder liner was considered. The low wear rate is attained by a lubricating film that is transferred from the rider to the liner. The compact is either (1) so hard (even at 1200°F) that it forms a minimal transfer film providing a slow but steady wear characteristic throughout the life of the rider or (2) soft enough to form a heavy, initial transfer film on the liner. This high initial wear rate is drastically reduced to small proportions in subsequent operation. In either case, the longest absolute wear life of the rider is the determining factor of success. In both cases, the wear of the hardened cylinder liner is negligible.

In the second concept, a hard rider, not considered a self-lubricating material, sliding against a hardened cylinder liner is incorporated. In this concept, the abrasion resistance of the respective sliding members,

especially that of the low surface energy hard coat on the cylinder liner, appears to be the limiting factor. An example of such combination would be a silicon carbide or chromium silicide rider sliding against a hardcoated Inconel 718 liner. If rider wear is excessive, the second concept could be incorporated in the first by hardcoating the piston land areas; the hard cylinder liner working against the hard piston wall would extend overall refrigerator wear life.

Thus far during the program, emphasis has been placed on achieving satisfactory performance by employing the first concept. That is, test hardware employs specially hardened liners against which low wear rate, high temperature, self-lubricating compact rider ring material rides.

Below is reviewed information on hot rider ring materials available at the start of the program.

## 2. HOT RIDER RING MATERIALS

As noted above, two concepts for testing rider/liner wear were considered at the beginning of the program. The first approach emphasized an expendable rider against a hard surface (the liner), while the second considered using two hard surfaces, neither of which would wear out during the required time frame. In regard to the first approach, a limited amount of information was available on a class of materials manufactured by The Boeing Company and the Pure Carbon Company. In theory, the Pure Carbon Company produces the same material as Boeing under special arrangements between the two companies.

Consistent with the Hughes philosophy of utilizing commercially available materials, the choice was largely restricted to the Boeing developed, Pure Carbon Molalloy compacts for this approach. Since the problem of residual oxygen in the working fluid (helium) in a cryogenic refrigerator is eliminated, the actual hot rider tests indicated the true erosive wear performance, i. e., there were no corrosive wear influences.

Table 1 lists the materials considered for testing. The following facts were known about these materials.



TABLE 1. CANDIDATE MATERIAL TO BE TESTED

Compact Identification		Elemental Composition, percent by weight	Hardness of Compact
Boeing Compact Co. No.	Pure Carbon Molalloy No.		
108*	PM-101	80 MoS <sub>2</sub> ; 20 Ta	Soft
4-122-1	PM-103	68 MoS <sub>2</sub> ; 20 Nb; 10 Mo; 2 Cu	Hard
6-84-1	PM-107	68 MoS <sub>2</sub> ; 20 Nb; 10 Mo; 1 Cu; 1 Ag	Hard

\*A hard variation of this compact (108-67), attained by some changes in composition, is also considered.

The Pure Carbon Company has not adopted all of the Boeing formulations for manufacturing. Since Boeing was still willing to supply any of its compositions, the equivalent candidates could be ordered from both sources. This would help meet material delivery schedules and, more important, uncover any quality differences in their respective final products. It should be noted that a given mixture of identical starting materials would not necessarily yield identical end products. An example of this was Boeing compact 046-45, an electrically conductive lubricative composite, which was selected as the material for the d-c motor brushes for the Surveyor surface sampler.

Photomicrographic examination of Surveyor III motor brushes, which successfully operated on the moon and that were returned by the Apollo XII astronauts, showed no major anomalies and moderate wear rates. However, there was some spalling and chipping at the commutator interface edges and corners of the brushes<sup>11</sup>. These findings prompted the selection of Molalloy PM-105 (the Pure Carbon equivalent of 046-45) for the motor brushes in the OSO despin mechanism. The PM-105 parts, however, exhibited a (higher) scleroscope hardness of 52, while the Boeing compact consistently displayed a hardness of only 10 (see Reference 12). A full year of d-c motor testing of both materials in dry nitrogen gas at laboratory ambient temperatures failed

to uncover any significant differences in wear due to the specific hardness of the respective compacts<sup>13</sup>. Yet to be established, however, is whether there was no real difference or whether the unit brush loads were different since the brushes were individually spring loaded.

Another area of information dealt with hardness. Hardness differences due to compositional variations between compact types could influence wear more than those due to differences in manufacturing methods of a single compact. Therefore, both high MoS<sub>2</sub> content (soft) and medium MoS<sub>2</sub> content (hard) compacts should be tested.

For example in the Boeing wear tests,<sup>5</sup> in which the control of oxygen in the material was questionable, Boeing compact 046-45 (equivalent to PM-105, high MoS<sub>2</sub> content) wore significantly more than Boeing compact 6-84-1 (PM-107 equivalent, medium MoS<sub>2</sub> content). The wear rate program could utilize Boeing compact 108 and its PM-101 equivalent (soft, high MoS<sub>2</sub> content\*), along with Boeing compact 6-84-1 (PM-107, hard, medium MoS<sub>2</sub> content) to observe the effects of hardness under more controlled conditions.

Another concern dealt with cost and schedule effects. A minor variation in composition could result in cost savings and timely deliveries, and the abrasion resistance would be the same. For example the variation between Boeing compact 6-84-1 (PM-107) and Boeing compact 4-122-1 (PM-103) appears to be small (see Table 1). PM-103, however, is now extensively used in the aircraft industry, while PM-107 is seldom prepared. Routine formulation means better availability, lower cost, more experience in machining, improved quality control, and reduced variation in batch-to-batch quality.

The only other high temperature compact considered was not commercially available. The Westinghouse developed gallium/indium/tungsten diselenide compact<sup>15,16</sup> was satisfactory for ball bearing retainers that had to operate over the required wide temperature range<sup>17</sup>. It also exhibited good frictional and film transfer characteristics in Hughes and

---

\* Hughes has had significant success with this material under laboratory ambient conditions and in tests of ball bearing retainers in vacuum<sup>14</sup>.

other industry friction tests at laboratory ambient temperatures<sup>18, 19</sup> This material is medium hard (scleroscope hardness = 37) and was considered as a reasonable secondary candidate. However, because it was not commercially available, the previously discussed materials were selected as primary candidates.

The potential success of the second wear testing approach, in which rider rings would be fabricated from extremely hard materials, was questionable. No hard materials were initially selected since the choice of steel alloys or hard refractory carbides, silicides, nitrides, or borides depends on physical constants as well as on commercial availability and machinability into hot rider forms. Initial selection was delayed in favor of expediting the first approach.

The foregoing summarizes the art of VM cryogenic refrigerator hot rider technology at the start of the program. Based on this information, a tentative test plan was formulated for the VM hot rider wear rate program. The two fundamental concepts of low rider wear presented above served as a guide for the initial tests.

The second major area of investigation at the start of the program dealt with selecting the cylinder liner material or surface approach. This selection effort and associated technology are described below.

### 3. PROPOSED HARDCOAT TREATMENT OF CYLINDER LINER

Inconel 718 is the piston/liner material in the present VM refrigerator designs. Initially, all hardcoat treatments were to be applied to this nichrome alloy. Appropriate hardcoats must be selected on the basis of compatible substrate chemistry and physical constants, e. g., closely matching coefficients of thermal expansion in the temperature range of interest.

All other parameters being equal, initial wear of a self-lubricating composite is associated with a narrow surface finish range of the mating sliding surface. The wear rates during the more advanced stages of sliding are functions of the initial surface finish of the substrate and the hardness and the surface topography of the transfer film. The scarce information available at the start of the program indicated a wear minimum somewhere within the 2 to 8 rms range of the initial surface roughness. The correlation between

transfer film topography and steady state wear rate must be established empirically.

The primary role of a hard, wear resistant liner coat is to compensate for the inherent softening of the liner alloy (now Inconel 718 whose  $R_C$  42 hardness at room temperature reduces, at  $1200^\circ\text{F}$ , to an estimated  $R_C$  33) and provide a hard ( $\sim R_C$  70 to  $R_C$  80) substrate, against which the wear of self-lubricating compacts is characteristically low. Additionally, the coating must adhere extremely well to the substrate and must have a good coefficient of thermal expansion match to withstand thermal cycling under abrasion without spalling. The deposition process must be well established, i. e., commercially available.

These considerations dictate the use of sputtering and ion plating of selected refractory carbides, oxides, nitrides, or silicides. The advantages of this as opposed to plasma spraying or flame plating, include close thickness control. A  $5000\text{-}\text{\AA}$  to  $10,000\text{-}\text{\AA}$ -thick sputtered or ion plated film closely follows the original as-machined surface contour and roughness. This alleviates the necessity of post operation machining. Another advantage of sputtering and ion plating is better adhesion due to atomic cleaning of the substrate by ion etching before deposition. Adhesion is also promoted by the subsequent, high energy impingement of coating constituents during the processes.

Endurex of Dallas, Texas, a firm involved in sputtering or ion plating of a refractory oxide or a silicide, has distinguished itself in successful pioneering work in this field<sup>20-23</sup>.

The initial work would involve sputtering  $5000\text{-}\text{\AA}$ -thick and  $10,000\text{-}\text{\AA}$ -thick layers of chromium silicide and a refractory oxide on flat Inconel 718 specimens at Endurex. These specimens would then be used in a Hughes developed method of interferometrically controlling film thickness<sup>24</sup> and for determining high temperature ( $1200^\circ\text{F}$ ) adhesion by stylus scratch tests<sup>24,25</sup>. Based on the thickness and adhesion tests, the best of the two coating candidates and the best thickness would then be selected and applied to a  $77^\circ\text{K}$  VM cryogenic refrigerator test liner.

The first two 77°K machines would test PM-107 (hard) riders sliding against bare and Endurex hard coated cylinder liners. These tests would be intended to demonstrate the usefulness of the hardcoat and cylinder material that appeared to be the most promising combination. A third test would tentatively be of a PM-101 (soft) rider versus a hardcoated liner to investigate the effect of rider hardness and composition on rider wear rate.

In the next section, the dynamic seal and rider (for ambient and cryogenic temperature) technology available at the start of the program is described.

#### 4. DYNAMIC SEALS AND RIDERS

It is now generally accepted practice that dynamic cryogenic refrigerator seals and riders operating at room temperature and below are fabricated from some type of PTFE (teflon) based self-lubricating composite. In most of these composites, inert fillers are used (e. g., ceramic powders, mica, glass fibers) to reduce wear rate, increase strength, and improve load carrying capacity. Some contain additional lubricating pigments (e. g., MoS<sub>2</sub>) to further reduce wear rate and friction.

Generally, the room temperature friction and wear behavior of glass fiber reinforced PTFE has been found satisfactory for most cryogenic refrigerator applications. However, cryogenic temperatures (i. e., at or below LN<sub>2</sub> temperatures) impose especially difficult conditions for the functional integrity of most plastics and elastomers used in seals. In order to obtain near zero leakage, a seal must have near total conformity; but the very low temperatures (as low as below 77°K) cause plastics to become brittle, to shrink, and to lose resiliency.

The literature gave conflicting statements about the wear of PTFE at low temperatures. There is a general consensus that teflon does not become brittle to 4°K, yet its coefficient of friction against hard metals may reach 0.3 to 0.4. The wear of teflon composite piston collar packing (operating in a pressure differential of 30 to 35 atm and at a sliding speed of 1.2 m/sec) also depended considerably upon temperature. The least wear was observed when cylinder wall temperature was 298°K (25°C). However, when the temperature dropped from 298°K to 223°K, collar wear increased by a factor of about 15 (Reference 26).



On the other hand, nearly all NASA research dealing with ball bearing lubrication at liquid N<sub>2</sub>, O<sub>2</sub>, and H<sub>2</sub> temperatures is on bearings using reinforced teflon composites<sup>27-29</sup>. Moreover, a very recent overview paper on seal ring design for extreme operating conditions recommended 30 percent glass filled PTFE for a closed cycle refrigerator piston ring seal working in 30°K helium gas<sup>30</sup>. Hughes experience with reinforced polymeric slides and seals agrees with this data. The present Hi Cap design utilizes 15-percent chopped glass fiber filled PTFE seal rings in the cold (cryogenic) seal area. Because these seals have been proven successful, there are no plans to change to another material.

In order to predict radial wear of seals and riders, it was decided to utilize the K wear factor and the equations based on theories by Archard<sup>31</sup> and other investigators, where volume wear W (in<sup>3</sup>) is proportional to load F (lb) times distance D (ft) traveled.  $W \approx FD$  or, in terms of velocity and time,  $W \approx FVT$ , where V = velocity (fpm), and T = time (hr). With the factor of proportionality K introduced, this equation becomes

$$W = KFVT \quad (1)$$

where K = wear factory, in<sup>3</sup>-min/lb-ft-hr.

If the configuration of a wear surface is known, volume wear W can be converted to radial wear R. For a fixed cylindrical bearing loaded unidirectionally, radial wear is obtained by dividing each side of Eq. (1) by the projected area of the wear surface.

$$R = KPVT \quad (2)$$

where

R = radial wear, inches

P = F/A, psi

Equation (2) is also used for predicting the radial wear of the hot riders.

---

\*PTFE, filled with proprietary inert fillers (chopped glass fibers with other ceramic fillers), manufactured by the Dixon Corporation, Bristol, Rhode Island.

The reported K factor for rulon A is  $2$  to  $4 \times 10^{-10}$  (reference 32), and for PTFE filled with 15-percent chopped glass fibers, it is  $16 \times 10^{-10}$  (reference 33).

With equations that it has developed, Hughes quantitatively determined differences in wear behavior at room temperature between two PTFE based, self-lubricating composites containing  $\text{MoS}_2$ . The objective was to choose the one that wore the least, yet adequately transferred film forming, self-lubricating composite ball bearing retainer material (teflon based). The two candidate composites were duroid 5813 and rulon A + 5 percent  $\text{MoS}_2$ .

A statistical test matrix was established for the LFW-1 friction and wear tester, operating in the oscillating mode, at room ambient temperature, in an argon atmosphere, with a 440C stainless steel sliding interface. The results in terms of the weight of the wear debris of the composites with time were then subjected to regression analysis to formulate the following factorial wear equations for

rulon A + 5 percent  $\text{MoS}_2$ :

$$W = 4.091 \times 10^{-13} P^{1.29} V^{2.42} T^{1.27} \quad (3)$$

duroid 5813:

$$W = 8.491 \times 10^{-10} P^{1.425} V^{0.665} T^{0.766} \quad (4)$$

where  $W$  is the wear weight in grams (instead of wear volume),  $P$ ,  $V$ , and  $T$  and the exponents as expressed previously (in terms of psi load, ft/min speed and minutes of operation, respectively).

Equations (3) and (4) were then examined to ascertain the uniqueness of the exponents. It should be pointed out that when a matrix is not unitary (in the present case the velocity of the test machine is not constant because of the variation in line voltage, which cannot be corrected by a constant voltage transformer), the least squares estimates of the parameters (in this case, the velocity) are sensitive to a number of errors. There are ways to augment the matrix to obtain biased estimates with smaller mean square error.

The analysis did not indicate that biasing offered any advantage; therefore, the minor variation in the velocity of the test machine is not a major influencing factor. It appeared that most of the errors stemmed from the fact that P, V, and T are not fundamental factors but are dependent variables themselves. Their use in equations of the advanced Archard-type is advantageous from the standpoint of simplicity only.

The cost of test machine design and fabrication and the development of sophisticated wear equations would far exceed resources available within the scope of the present work. They are not, therefore, being pursued at this time.

## A. Predictability of Polymeric Seal/Rider Performance

One major goal of the VM wear rate program is to substantiate or modify the published K factors, as specifically applicable to the polymeric seals and riders of cryogenic refrigerators. This concept is especially important in view of the fact that the factors were developed with journal bearing testers, in a unidirectional mode, and under loads and speeds significantly higher than those that refrigerators experience.

Hughes research indicated that the exponents of Eqs. (1) and (2) are not unity. In other words, radial or volume wear does not linearly increase with load, speed, or time. The equations are, therefore, only approximations, and the proportionally constant K is a real constant only if the exponents of P, V, and T are experimentally determined for each self-lubricating composite. Otherwise, K is only approximate, depending on the experimental conditions.

For these reasons, the forthcoming refrigerator tests will serve to establish approximately the experimental K factors of the Archard Eq. (2) for not only the hot, but the cold riders and seals as well. These factors will then help in predicting long term wear more accurately if the periodic examination of the riders and seals shows no significant changes in K as the test progresses. If the magnitude of the factors appeared to monotonically increase or decrease with time of sliding, proper corrections can be made.



## B. Proposed Approach to Wear Equations for Cold Riders and Seals

In case the refrigerator tests show that the polymeric cold riders and seals are wearing too much, there are three approaches for further work:

1. Select alternate rider materials on the basis of vendor commercial data and industry experience. Note that friction and wear data on plastics at low and cryogenic temperatures is extremely sparse and (as mentioned before) is limited to reinforced teflon composites. Only in Reference 34 was there some preliminary data on the use of polyimide for seals down to  $-65^{\circ}\text{F}$ . The work at Picatinny Arsenal (Reference 34) was discontinued some time ago, and there is no concerted effort at the present time to collect and publish low temperature physical constants and other data on plastics. Phone calls to the manufacturers revealed no useful information.
2. Design and construct a device to test friction and wear at cryogenic temperatures and develop factorial wear equations by means of statistical test matrices.
3. Approach predictability of polymeric composite wear on the basis of viscoelasticity fundamentals. In spite of the immediate advantages of the advanced empirical equations that Hughes proposes in lieu of actual low temperature friction and wear tests, additional theoretical and parallel practical work should be done based on some recent preliminary in-house research. A fully fundamental approach to polymeric/composite wear is described below.

## C. Wear Prediction on the Basis of Viscoelasticity Fundamentals

The abrasion or wear of polymeric materials is generally described in terms of an elastic (stored) energy and an inherent rupture energy for failure. This approach is based on a criterion for failure given by the Griffith crack theory<sup>35</sup>. The crux of this theory is simply that an increase in surface energy by material separation is equal to a corresponding loss in the stored energy. In other words, the energy necessary for the propagation of a failure mechanism is provided by the energy stored following a perturbation. Quite

naturally, therefore, the wear of a polymeric material will be proportional to this stored energy and inversely proportional to the rupture energy as follows:

$$W \propto \frac{\text{elastic energy}}{\text{rupture energy}} \quad (5)$$

These properties are related to experimental parameters that are easily measured. The elastic energy potential of a material is obtained by measuring the dynamic storage modulus  $E'$ , which is a fundamental material property<sup>36</sup>. The rupture energy is related to the material ultimate strength. It is only necessary to realize that these bulk material properties depend on test conditions such as deformation rate and temperature. Consequently, Eq. (5) can be written in the following form.

$$W(T, \omega) \propto \frac{E'(T, \omega)}{\text{UIS}(T, \omega)} \quad (6)$$

where  $T$  and  $\omega$  indicate the time-temperature dependencies and UIS the ultimate strength.

Equation (6) describes the fundamental criteria for bulk material failure in terms of a unit amount of supplied energy. The modulus, for example, is defined in terms of a direct application of normalized loading. A treatment of wear for the dynamic sliding application must consider the energy transfer process between the sliding surfaces of two materials. A certain amount of the work applied to the sliding action is dissipated through frictional losses.

The mechanical energetics at the interface of two sliding surfaces are considered in terms of a coefficient of kinetic friction  $\mu$  (sometimes expressed as  $f_k$ ). This coefficient is defined as the ratio of the force required to slide one surface over the other to the normal force pressing them together. In the limiting case where  $\mu$  is equal to unity, the energy transfer will be maximum. For values less than unity, the energy available for a failure process  $E'$  and hence, the wear, will be fractionally reduced. In other words, only a fraction of the elastic energy resulting from a direct loading will be

available, i. e.,  $\mu - E'$ . Therefore, Eq. (6) is expressed in equality form as follows<sup>37</sup>.

$$W(T, \omega) = \frac{\mu(T, \omega) E'(T, \omega)}{UIS(T, \omega)} \quad (7)$$

The coefficient of friction in Eq. (7) is expressed as a function of rate and temperature because it should vary in analogous fashion as the mechanical property parameters. Indeed, the work of Grosch<sup>38</sup> and Bartenev<sup>39</sup> have shown that variations in the friction coefficient for polymer applications are directly related to energy losses in the material. Such energy losses are a maximum in regions of the glass to rubber transition, of crystalline morphology changes, and of other secondary transitions. Grosch illustrated that  $\mu$  attains a maximum value of 2 to 3 when the polymer response is in the glass to rubber transition,<sup>\*</sup> whereas Bartenev reported a maximum  $\mu$  value of the order of 0.4 for mechanical responses in the secondary transition regions. Therefore, it should be possible to generate curves of  $\mu$  as a function of rate or temperature if the dependency of the bulk property transitions are known. Such transitions are readily obtained from dynamic modulus curves over the rates or temperatures of interest.

Eq. (7) suggests that the wear characteristics of a polymeric material can be predicted simply if one knows its mechanical properties. It is necessary, however, to translate the mechanical property parameters, measured at a given bulk deformation rate, to those obtaining at a rate corresponding to a surface deformation. The surface deformation is difficult to define because a discrete cross section is not acted upon. However, Ludema and Tabor<sup>40</sup> have obtained an experimental correlation between the bulk property strain rate and surface sliding speed reported as  $10^6$  cm/sec to 1 cm/sec, respectively.

---

\*Theoretically, a coefficient of kinetic friction cannot exceed unity; however, a complex loading phenomenon in flexible materials precludes a simple interpretation of friction.

# Contrails

In the preliminary work reported here, an effort was made to obtain the input data for Eq. (7) only from curves of dynamic modulus as a function of temperature. As a first step, the modulus curves were transformed in order to account for the difference between the bulk rate and the sliding rate. In effect, this amounted to simply shifting the modulus curves horizontally along the temperature axis. The necessary shift was determined from a WLF transform expressed as follows<sup>41</sup>:

$$\log \frac{\dot{\gamma}_0}{\dot{\gamma}} = \frac{Q}{R} \frac{1}{T} - \left( \frac{1}{T_0} \right) \quad (8)$$

where

$T_0$  = reference temperature (in this case the bulk property rate temperature)

$T$  = transformed temperature (modulus response at a corresponding sliding rate)

$R$  = universal gas law constant

$Q$  = activation energy\*

The transformed curves yielded the  $E'(T, \omega)$  values for input to Eq. (7).

The UIS ( $T, \omega$ ) values were calculated from the transformed modulus curves by using a variation of the Boltzmann principle<sup>42</sup>. The equation used was of the following form:

For  $T > T_{\min}$ ,

$$\text{UIS}(T) = \frac{Q}{R} \int_{T_{\max}}^T e^{Q/RT} E(T) \frac{dt}{T^2} \quad (9)$$

---

\*An average value of 10K cal/mole was used according to the work in reference 40.

For  $T \leq T_{\min}$

$$\text{UIS}(T) = \frac{Q}{R} \int_{T_{\max}}^{T_{\min}} e^{Q/RT} E(T) \frac{dt}{T^2} \quad (10)$$

Here  $T_{\max}$  refers to the limiting temperature at which the modulus tends to zero. The maximum temperature for which modulus values were experimentally determined was used for this boundary because complete modulus curves were not measured. Relative changes in the ultimate strength values were not affected by this alteration. The value  $T_{\min}$  refers to the minimum temperature below which molecular response variations no longer affect the material strength. This predicts that the ultimate strength will not vary with temperature below a certain level. Extensive work by Smith<sup>43</sup> has shown this to be the case. The lowest temperature at which modulus measurements were made was used for  $T_{\min}$  in analogous fashion to the selection of  $T_{\max}$ .

Curves of coefficient of friction as a function of temperature were obtained by simply matching the data of Ludema<sup>40</sup> with the transformed modulus curves. For example, a maximum in the  $\mu$  curve was shifted to coincide with transitions in the modulus curves. A  $\mu$  value of 0.4 was chosen for the maximum in agreement with the literature<sup>44</sup>.

In the final analysis, Eq. (7) does not offer an absolute value for wear in terms of weight or volume losses. Its derivation is based on intrinsic energy requirements for wear with no supposition regarding the actual amount or geometry of an element of material acted upon. Nevertheless, it offers one a means by which to compare the relative wear of materials as a function of temperature or sliding speed.

## SECTION III APPROACH TO WEAR TESTING

The wear test program consists of three basic types of efforts. The first is directed toward selecting and screening candidate materials used for hot displacer rider rings in 77°K VM refrigerators. The second is directed toward verifying the life expectancy of rider rings and of other critical components when they are operated on an accelerated basis in an accelerated wear rate test module. The third effort is directed toward verifying findings in a Hi Cap refrigerator during endurance tests. The interrelationships of these efforts are pictured in Figure 1 and discussed in detail in the following paragraphs. Also provided is a discussion on test criteria as initially proposed for the program.

### 1. WEAR TESTING WITH 77°K VM SYSTEMS

As indicated in Figure 1, the candidate materials for the hot displacer rider rings were selected in two steps. The first involved an investigation of suitable materials that are now commercially available as well as a review of manufacturers' specifications for such materials.

To aid in the selection of the best material, three GFE VM refrigerators that Hughes Aircraft Company had built were made available. Figure 2 shows one of these 77°K VM refrigerators. In refurbishing the refrigerators, emphasis was placed on incorporating provisions for obtaining real time data on the effectiveness of candidate rider ring materials. The objective of this effort was to obtain test data on hot rider ring materials and to verify the accuracy of initially quoted specifications. The number and type of items that were replaced during refurbishment as well as the number of hours of operation are being documented in order to provide additional data on the performance of bearings, seals, and other critical refrigerator elements.



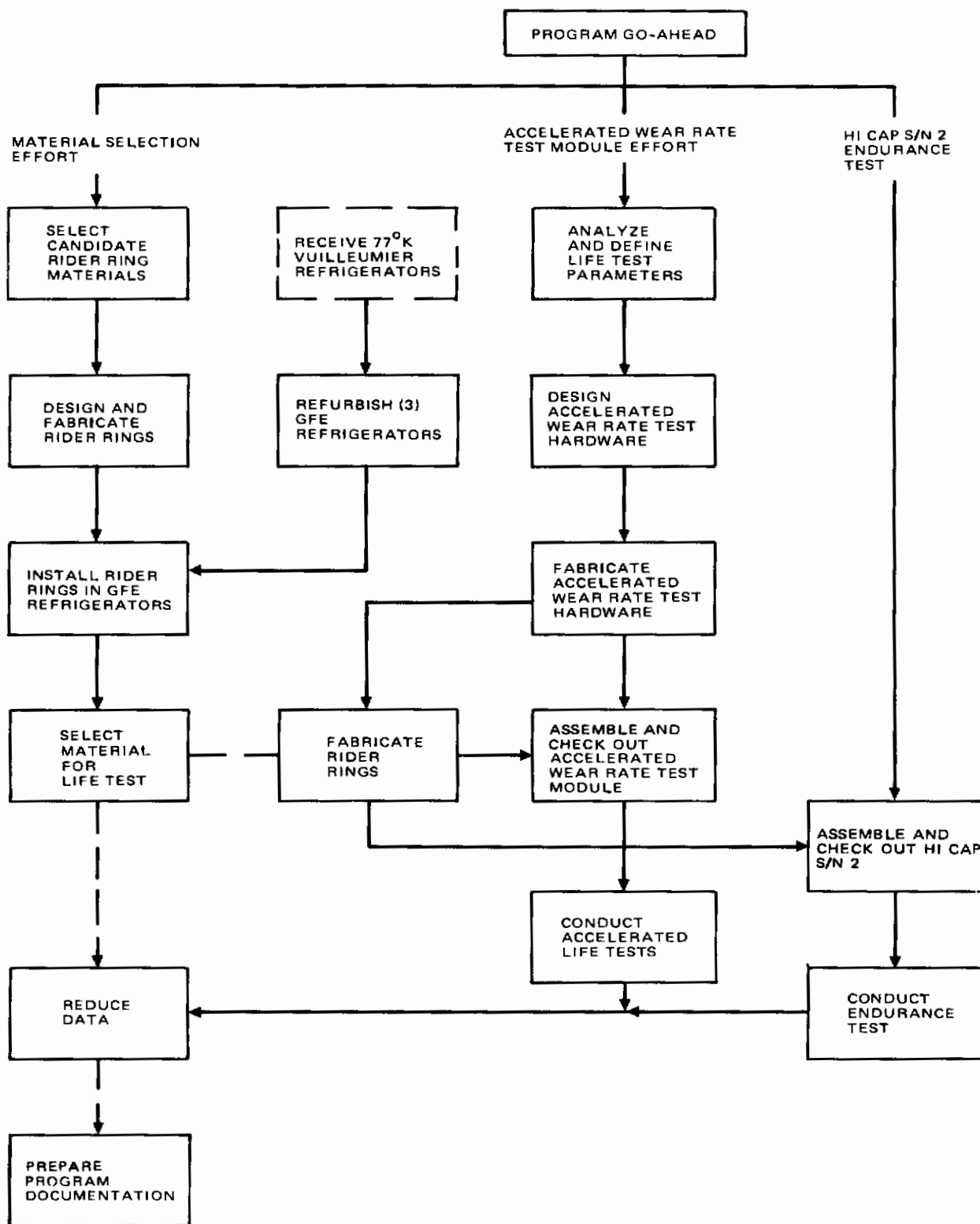

Figure 1. Outline of wear rate test program

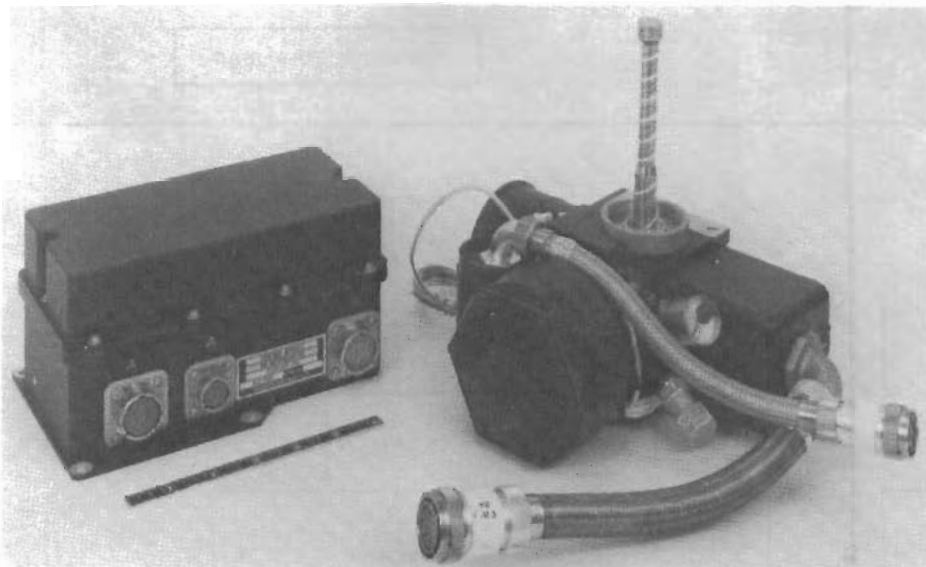

Figure 2. Airborne VM refrigerator manufactured by Hughes Aircraft Company (4R18086)

Rider rings for each of the available VM refrigerator test units have been fabricated from the primary candidate materials. Fabrication techniques are completely defined and subject to stringent quality control. Physical characteristics are carefully inspected and documented to ensure that the baseline definition is available for use in later comparisons. These characteristics, which include surface finishes as well as the dimensions and weights of components, are carefully monitored. The scope and methodology applied in the screening tests are discussed later in this section.

At three-month intervals throughout the tests, the values of the parameters associated with the candidate rider ring materials are measured in order to obtain wear rate data. As part of this test activity, care is exercised that both the methods of inspection and the test intervals do not invalidate the test data or unduly influence the operating life of the components.

The 77°K VM refrigerators are designed for airborne use. Since they are considerably different from spaceborne refrigerators, especially in



terms of size and operational speed, the data obtained with them is subject to scaling factors in order to more realistically predict the relative merits of the materials considered for use in spaceborne refrigerators.

The data obtained as a result of these screening tests is promptly reviewed in order that the most promising materials may undergo further tests during the next phases of this effort, i. e., tests with the Hi Cap S/N 2 refrigerator and the accelerated test module.

Figure 3 (which is supplemented by Table 2) is a schematic of the test set-up used in screening the candidate materials. After the rider rings made from the candidate materials are installed, the 77°K VM refrigerators are moved to the test facility. The special test equipment (STE) provides electronic control and hot cylinder overtemperature protection as well as drive motor power for each refrigerator test. The STE also incorporates provisions for recording elapsed test time, pressure, speed, characteristic temperatures, and the power applied to the hot cylinder.

The figure and table describe some of the data collected for diagnostic purposes, including that on

- Cold cylinder temperature
- Crankcase temperature
- Cyclic speed
- Power to drive motor
- Hot cylinder temperature
- Refrigerant pressure

The data is recorded automatically, but care is taken to collect no more data than is necessary. This approach has been taken in order to keep information on key items from being lost in a mass of general information.

## 2. WEAR TESTING WITH ACCELERATED WEAR TEST MODULE

The primary objective of this second effort is to verify rider ring life in hardware that simulates a Hi Cap VM refrigerator but on an accelerated basis. In addition, all other basic VM components in this hardware, such as

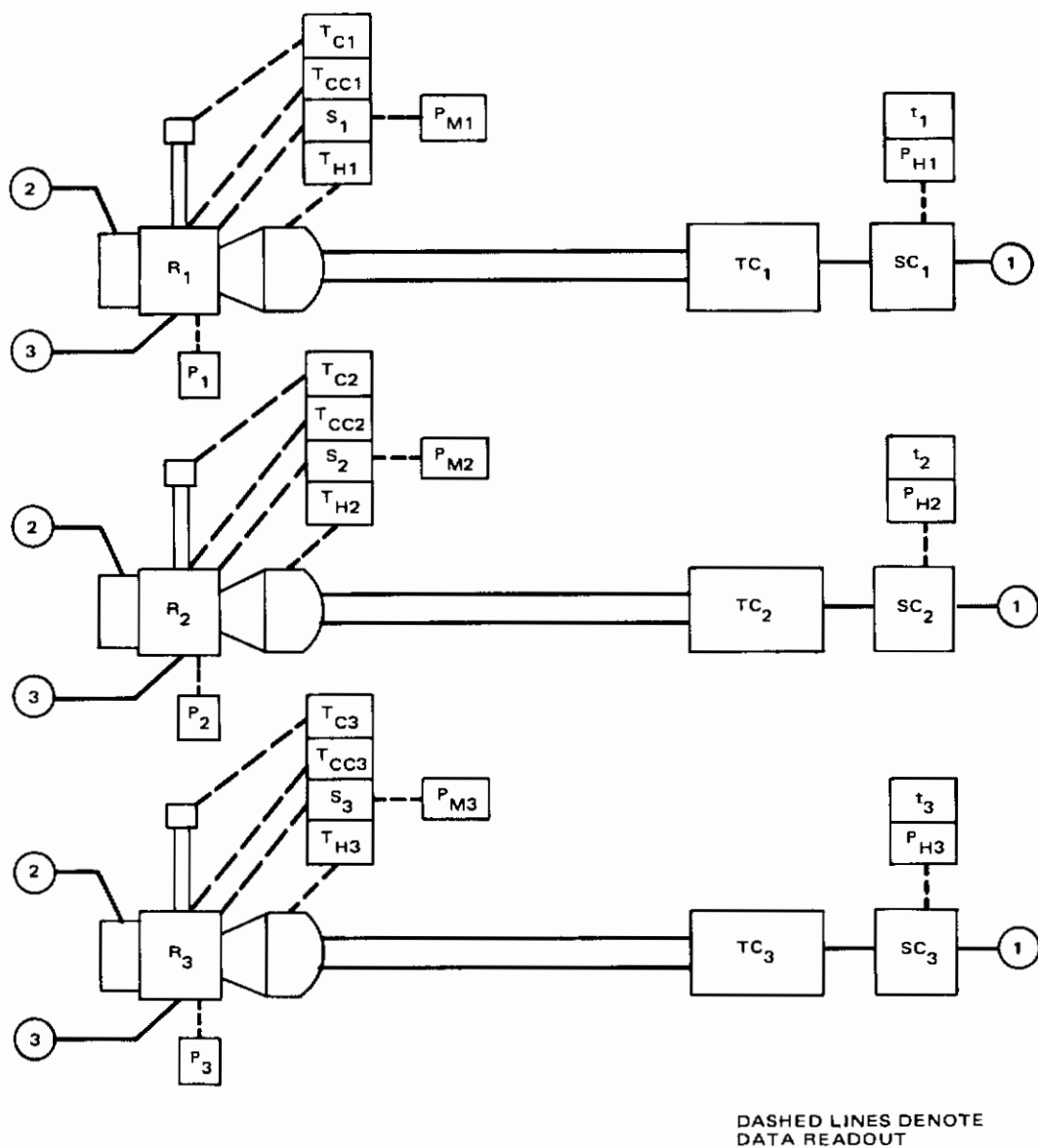

Figure 3. Preliminary test set-up for material selection tests (see Table 2 for definition of symbols used)

TABLE 2. DEFINITION OF TERMS USED IN FIGURE 3

Symbol	Parameter
①	Common 28-vdc power
②	Common 400-Hz, 115-vac power
③	Common 80-Hz, 28-vac drive motor power
$R_i$	$i^{\text{th}}$ refrigerator (GFE)
$TC_i$	$i^{\text{th}}$ hot cylinder temperature control
$SC_i$	$i^{\text{th}}$ system controller
$T_{ci}$	$i^{\text{th}}$ refrigerator cold cylinder temperature
$T_{cci}$	$i^{\text{th}}$ refrigerator crank case temperature
$S_i$	$i^{\text{th}}$ refrigerator cyclic speed
$P_{Mi}$	$i^{\text{th}}$ refrigerator drive motor power
$T_{Hi}$	$i^{\text{th}}$ refrigerator hot cylinder temperature
$P_i$	$i^{\text{th}}$ refrigerator fill pressure
$t_i$	$i^{\text{th}}$ refrigerator test time
$P_{Hi}$	$i^{\text{th}}$ refrigerator power to hot cylinder

seals, bearings, rider rings, and sensors, will be evaluated in terms of operating life. In these accelerated tests, hot rider rings made of the more promising materials identified during the screening activity are being used. While the output of the screening effort is data that indicates wear life trends, the accelerated wear rate test module should provide data that is directly applicable in determining the overall operating life of Hi Cap type refrigerators. This is true because this module will embody as many of the components of the Hi Cap machine as practical.

Before work on the mechanical design of the accelerated life test module began, a thermal analysis was conducted to determine the

appropriate volumetric relationships within the module needed to achieve pressure ratios typical of VM refrigerators. In addition, the nominal helium pressure levels were defined for the higher speeds; this effort established what the pressure drop in the hot regenerator is in order to simulate actual values encountered with spaceborne refrigerators. For example, if the speed is increased three times over the normal value to achieve the mass flow rate for the same pressure ratio, a threefold reduction in base cycle pressure was found to be required. The pressure drops must be identical in order to keep the bearing load constant between the simulated test module and an actual refrigerator.

Figure 4 illustrates the accelerated wear rate test module. This module is based on the same hot cylinder/crankcase design and materials as the Hi Cap refrigerator but does not include a cold displacer/cold cylinder assembly. This assembly is not needed in order to meet the program objectives. This module operates at speeds to 750 rpm. More detailed aspects of the hot displacer as well as the rider rings are shown in Figure 5. The O-ring seals are utilized with the test module for ease of assembly and lower cost. These adequately seal the test vehicle.

Most refrigerator components that are typically required in an actual Hi Cap VM refrigerator, e. g., seals, bearings, sensors, etc., are needed in the test module. Therefore the tests provide an opportunity to gather

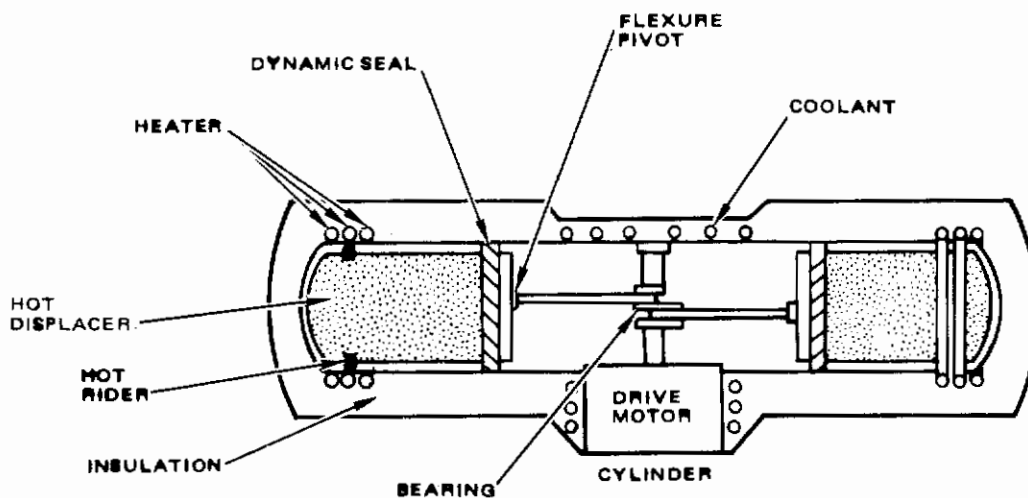

Figure 4. View of accelerated life test module

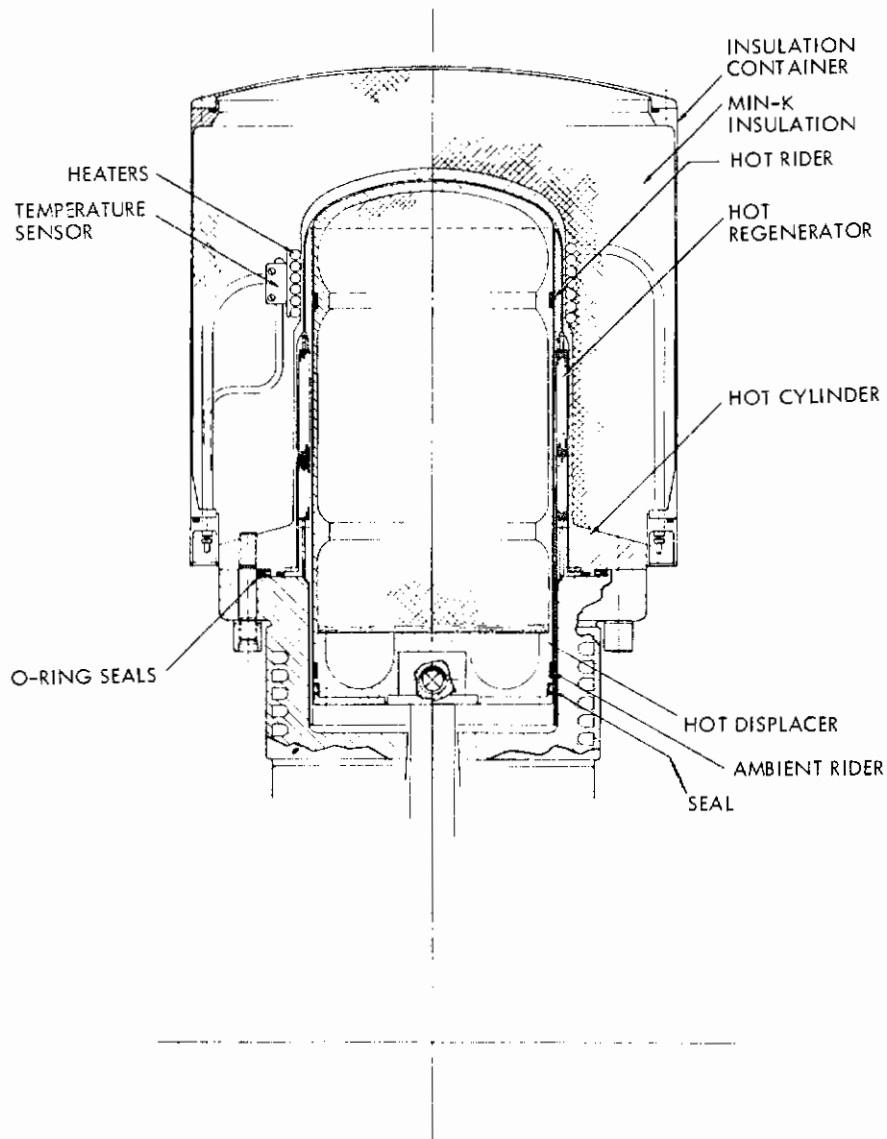

Figure 5. Cutaway view of VM refrigerator hot displacer area

life test data on these items and to determine whether other life limiting components exist. These will include such factors as

- Bearing and flexure pivots
- Dynamic seals
- Heaters
- Temperature sensors

- Material stability
- Contamination

The test module and its support equipment are designed to allow the values of such operational parameters as

- Orientation
- Temperature
- Fill pressure and pressure ratio
- Cyclic speed

to be varied. Again, great care has been exercised during the fabrication and assembly of the test module to ensure that suitable baseline information on such items as surface finishes, component dimensions, etc., is obtained and documented for later comparisons. As in the material screening effort, care will be taken that neither the test data nor the test duration is adversely affected by these inspections.

Before either test program was begun, a test plan was prepared. This document defines what data is to be gathered and the purpose for which it is to be used. This data includes:

- Test equipment to be used
- Test standards
- Data to be collected (and the method to be followed in obtaining it)
- Frequency of data collection
- Method of data presentation
- Method of evaluating data on useful operating life

A copy of this test plan is included in this report as Appendix A.

### 3. HI CAP REFRIGERATOR ENDURANCE TESTS

Hi Cap refrigerator S/N 2 has been furnished as GFE for tests to aid in determining the actual operating life of a VM refrigerator. The purposes of these tests, which consist of four incremental periods of 2500 hours each, are to demonstrate that the components in this refrigerator can operate



# Contrails

satisfactorily for at least 10,000 hours and, more important, to develop wear rate data from an actual VM refrigerator designed for space based operation; this data will be used to predict operating life expectancy.

Before these tests were begun, ion plated sleeve inserts were placed in the hot cylinder liners for the Hi Cap refrigerator. This was necessary because the liners for refrigerator S/N 2 became scored when used during the developmental test of Hi Cap S/N 1.

Two sets of hot rider rings for the Hi Cap refrigerator were fabricated from Boeing 6-84-1 and Pure Carbon PM-107. The former rider rings are now being evaluated. Material traceability and fabrication techniques associated with this effort have been subject to strict quality assurance provisions.

The rider rings as well as other critical components were measured during the final assembly of the Hi Cap refrigerator before the endurance tests began. These measurements will serve as a baseline for later analysis. One set of the new hot rider rings has been supplied to the customer for his inspection and evaluation.

At present, Hughes does not propose to further evaluate rider rings made of AmCerMet in the incremental endurance tests. A total of 2400 hours of test time was accumulated during the developmental tests of refrigerator S/N 1 with this material, and it was noted earlier that, based on the results of development tests, Hughes is not confident that this is the most promising rider ring material.

Since final conclusions from the 77°K VM screening tests were not available at the start of endurance tests, the material used for the first set of rider rings was selected on the basis of the best information available during the material selection process.

The endurance tests of the Hi Cap refrigerator are being conducted in the laboratory of the Cryogenics Department of Hughes Aircraft Company. The temperature of the coolant supplied to the refrigerator is maintained at approximately 70°F; coolanol 15 is utilized as the heat rejection fluid.

The design heat loads (12, 10, and 0.3 watts) have been applied to the first, second, and third stages, respectively, and will be continued for as long as the cold cylinder heaters remain functional. The cooler is being

operated in several orientations with the cold cylinder axis in both the horizontal and the vertical position. The orientation of the refrigerator is changed every three weeks. A complete set of data is recorded daily and summarized weekly.

The incremental test period is 2500 hours. For the 87-percent effective use of time assumed, the 2500-hour test period covers approximately four months. After this test period, gas samples are taken from the refrigerator. The refrigerator is then disassembled and the torque at the crankshaft measured. The components subject to wear are inspected, measured, and weighed as appropriate. If it is found that wear rate of the hot cylinder rider ring is excessive, this ring will be replaced with one made of an alternative material. Findings and conclusions in regard to life expectancy are discussed in later sections of this report and documented in a test report.

Following inspection, the refrigerator is reassembled and a second 2500-hour period of testing initiated. A new sample of gas is drawn and analyzed to provide baseline data. Below are discussed the criteria used during the test program.

#### 4. WEAR TEST CRITERIA AND EVALUATION TECHNIQUES

Wear rate criteria and evaluation factors were established early in the program for most of the potential life limiting components in the refrigerator. The approach involved defining dimensional, surface, operational, and weight changes as a function of operating time.

In order to establish viable wear criteria, several characteristics associated with each component must be determined.

These include such items as:

- Component function
- Failure mode
- Allowable changes after 30,000 hours of operation
- Component loading or stress levels
- Effects of primary and secondary failures on cooler performance

Table 3 lists six major components that were to be evaluated during the program and indicates what effect their failure would have on the



refrigeration system. Table 4 describes the function of each component and the evaluation technique to be employed during the program.

It should be noted that a method to ascertain deterioration in flexure pivot performance short of a parallel statistical program has not been formulated. During the present program, flexure pivot status is limited to "go or no-go" type of data, i. e., the pivots are either functioning or have failed after some accumulated number of hours.

TABLE 3. EFFECT OF COMPONENT FAILURE (OR EXCESSIVE WEAR) ON COOLER PERFORMANCE

Component	Type of Failure	Effect of Failure on Performance
Rider ring	(Primary)	Frictional forces increase until refrigerator stops
	(Secondary)	Excessive amount of debris impairs performance
Dynamic seals	(Primary)	Refrigerant leakage impairs efficiency and can cause loss of performance
	(Secondary)	Increases frictional forces
Bearings	(Primary)	Causes refrigerator to stop
	(Secondary)	Increases drive motor torque requirements
Hot cylinder heater	(Primary)	Shuts down primary refrigerator input power with subsequent loss of performance
	(Secondary)	Reduced input power impairs performance
Hot cylinder sensor	(Primary)	False overtemperature indication causes system shutdown
	(Secondary)	Loss of accurate temperature control causes erratic performance
Flexure pivot	(Primary)	Causes unstable operation with ultimate mechanical shutdown
	(Secondary)	Results in unstable and rough mechanical performance

TABLE 4. POTENTIAL LIFE LIMITING COMPONENTS, FUNCTIONS, AND EVALUATION TECHNIQUES

Component	Function	Evaluation Technique
Rider rings	Separate moving surfaces	Use dimensional and weight changes in general wear equation
Displacer seals	Control refrigerant flow at moving surfaces	Use dimensional and weight changes in general wear equation
Ball bearings	Allow relative motion with minimum force	Use weight and characteristic performance changes in standard equations
Hot cylinder heaters	Furnish primary input power to refrigerator	Note variation in resistance values (go/no-go trend)
Hot cylinder temperature sensors	Control primary power to refrigerator	Note variation in resistance values at designated temperatures (go/no-go trend)
Flexure pivot	Allow relative motion with minimum force	No technique at present; statistically oriented program needed

Brief comments on each of the components described in the tables are given, and the criteria and data presentation are discussed in the following paragraphs.

#### A. Rider Rings

The primary function of the hot and cold rider rings is to separate the reciprocating displacer from the fixed cylinder wall and to provide a wear surface between them. If the displacer and cylinder come into contact, scoring or galling of the mating surfaces and an increase in frictional sliding force result. If such a condition continues, the system will stop. One method of extending rider life is to increase the amount of rider surface; however, this greater surface area can result in more wear debris as the rider performs its function. This method therefore has real limitations. If more debris is formed than the design of the refrigerator can tolerate, some of it will migrate into the regenerator and bearing areas and cause secondary failures.

A standard equation for evaluating rider wear is

$$V = KN V_{avg} T$$

where

V = volumetric loss of material

K = wear constant

N = normal force causing wear

$V_{avg}$  = relative average velocity

T = operating time

The forces acting on this rider are functions of crank forces, inertia, and gravity. For a spaceborne cooler, two force conditions exist, one during ground based operation where there are gravitational forces, and a second when the cooler is in space and this force is reduced.

Figure 6 shows three conditions that could occur during the tests. In each of the graphs, the loss in rider ring material volume is plotted as a function of operating time and is based on the standard wear equation. The radical change in slope is due to the reduction in normal rider forces occurring in a space environment.

Figure 6a illustrates the condition where rider ring wear and the decrease in displacer/cylinder clearance is the limiting parameter. The "allowable wear" indicates minimum acceptable clearance; the "maximum wear" indicates that the components are in contact. Figure 6b illustrates where debris formation is the limiting parameter; again, minimum allowable and maximum tolerable limits are shown. Obviously, from the standpoint of dead volume and optimum design, the condition depicted in Figure 6c is favored.

Efforts are now being directed toward establishing the numerical values of the limits as well as the slope of the wear curve. The wear debris problem is expected to be mainly associated with the hot cylinder rider ring. Wear debris associated with ambient and cryogenic rider rings has not and is not expected to be a problem.

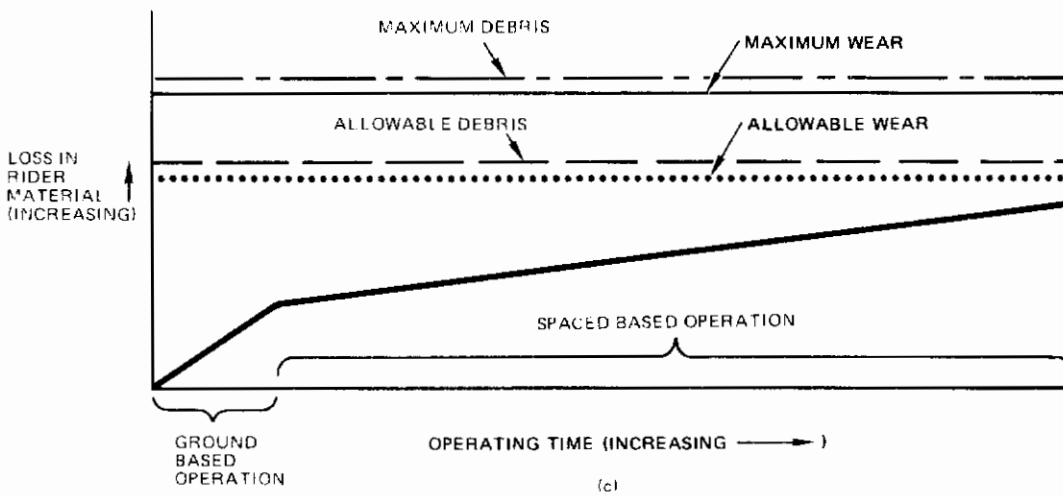
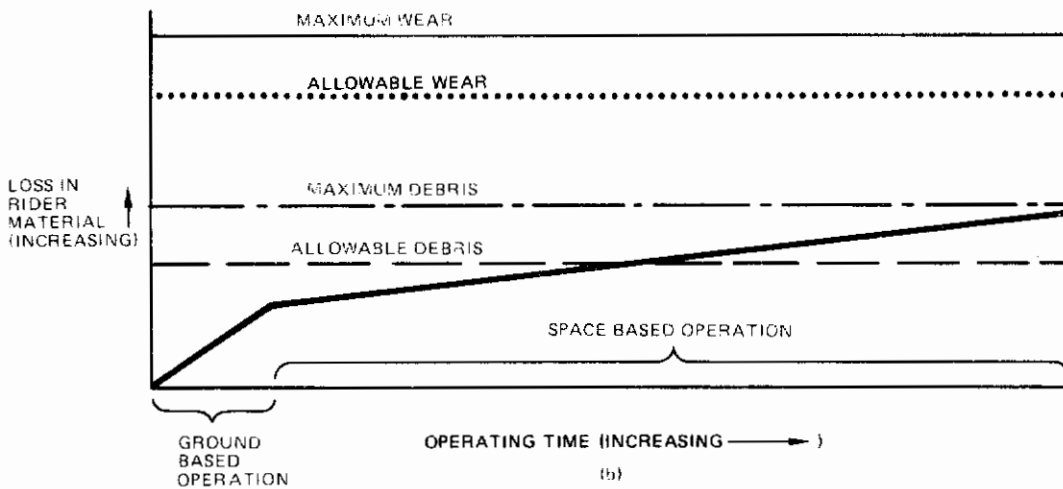
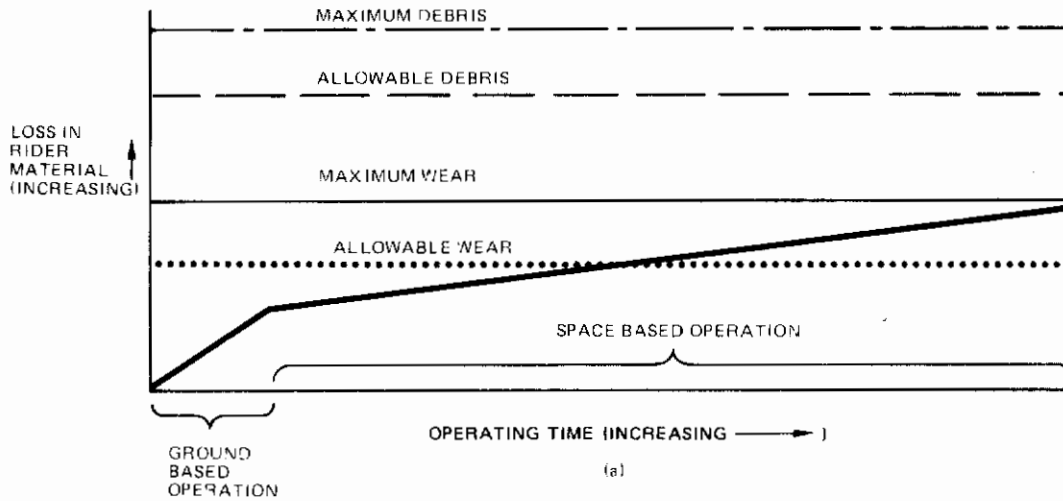

Figure 6. Wear characteristics of rider ring

## B. Displacer Seals

The primary function of displacer seals is to ensure that the refrigerant is directed to the regenerators without bypass leakage. When leakage occurs, regenerator efficiency quickly degrades and an overall loss in refrigeration performance results. Present plans are to use seal weight loss to indicate seal volume loss. The approach used to predict rider ring life will then be applied to the dynamic seals.

A seal fails ultimately when the expansion spring protrudes through the basic seal surface. In this case, the friction force will be similar to that when the rider ring fails. However, it is expected that gross leakage would so decrease performance that the refrigerator would shut down before this occurs.

Figure 7 shows dynamic seal wear as a function of operating time. This is similar to the curves shown for rider rings except that the break between ground based and space based operation is less pronounced because the pressure drop forces across the regenerator (which act on the seal) are the predominant forces. A theoretical case of high versus low pressure drop forces is shown in the figure. The allowable and maximum values of wear debris have not been shown in the figure since they are expected to be very minimal.

## C. Bearings

Bearings orient the moving members and minimize frictional forces. A primary wear failure mode would be when there is so much wear between the balls and their retainer that the balls would break through the retainer. In this case, the dimensional inspection criterion would be applicable. Regular inspection of the balls and race surfaces will further aid in defining wear life.

Somewhat complex is the effect of wear debris on both bearing performance and life. Currently it is planned to measure the torque of a bearing when it is removed after a test and then to measure it after the bearing has been cleaned. This data should yield graphic information as shown in Figure 8.

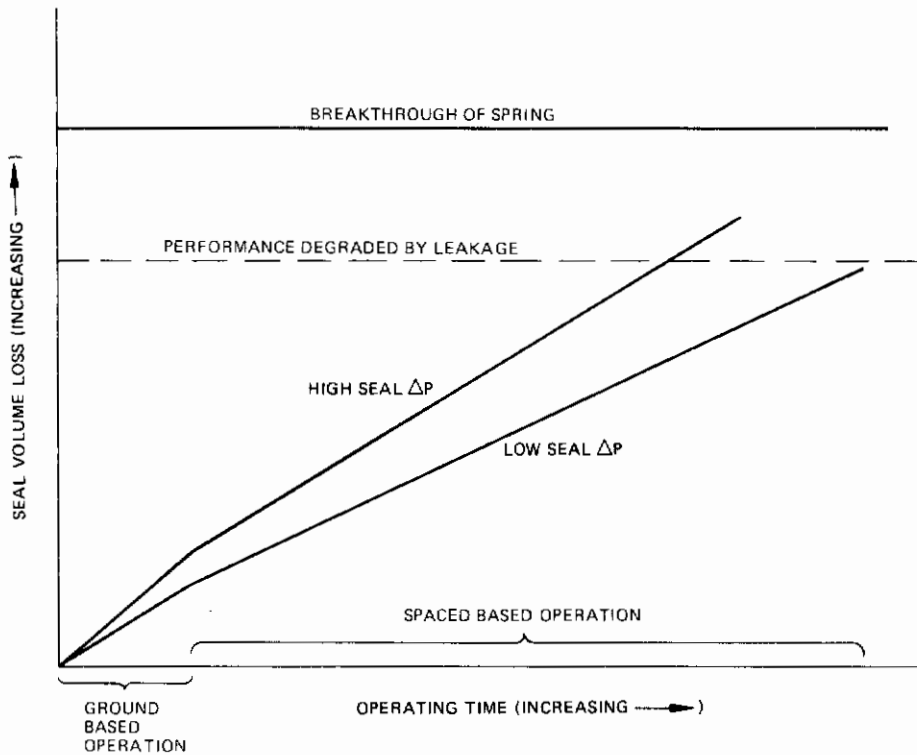

Figure 7. Wear characteristics of dynamic seals

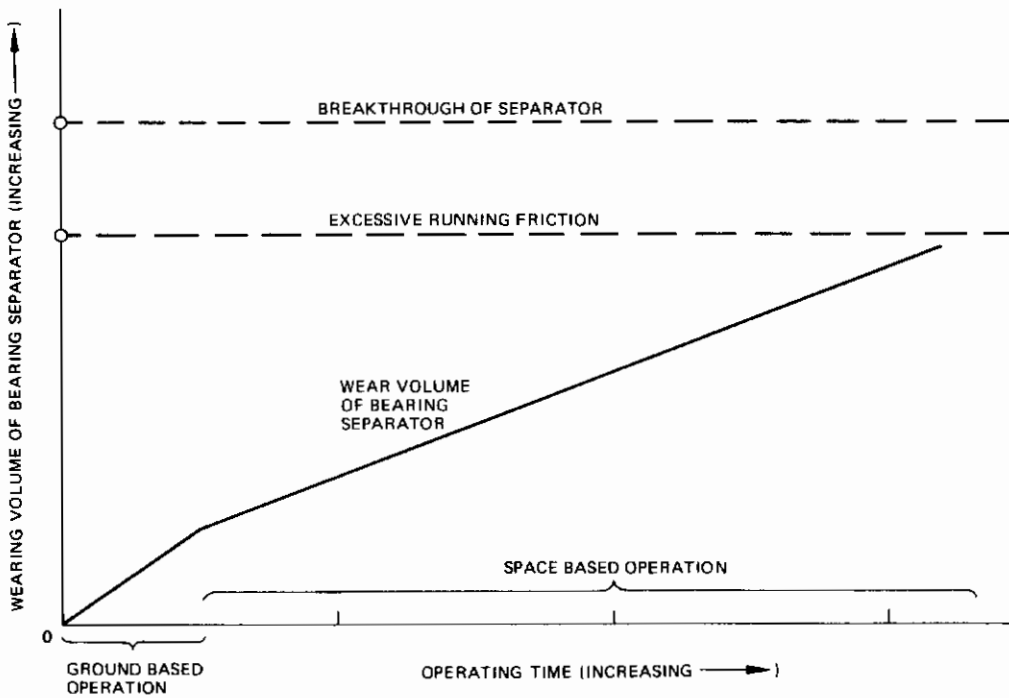

Figure 8. Wear characteristics of bearing separator



## D. Hot End Heater

Ultimate failure of a hot cylinder heater occurs when it can no longer deliver rated thermal energy to the refrigerator. Typically the failure mode results from a weak spot in the basic element, which then burns through and yields an open circuit. Since heater installation precludes visual or x-ray inspection, the only measurable parameter is electrical resistance. This value will be measured as a function of operating time in an attempt to establish some type of failure pattern. However, since this provides a very limited sample lot, definitive results, short of failure-free operation, or complete failure, are not expected from the program. A parallel statistically oriented program would be needed to accumulate additional data on this component.

## E. Hot Cylinder Temperature Sensors

The hot cylinder temperature sensor acquires information needed to regulate power to the heaters. If the calibration of this component shifts or the component fails, effective temperature control is prevented. The test criterion involves measuring electrical properties under definite conditions as a function of operating time. This data could yield information on pre-failure patterns; however, the limited samples will indicate only trends and then only if failure occurs. As with the heaters, a statistically oriented program would be needed to provide high levels of confidence.

## F. Flexure Pivots

The flexure pivots, similar to bearings, provide for displacer orientation and relatively low frictional force motion. Failure history indicates that the primary mode of failure is a stress induced rupture of the flexing part of the pivot.

Thus far, selection of this component has been based on vendor calculations and recommendations coupled with a generous added factor of safety. Short of destructive test methods, the only test criterion involves operating the component until failure occurs. So far, no inherent property of the component has indicated degradation due to fatigue.

## SECTION IV DESCRIPTION OF WEAR TEST HARDWARE

This section describes the hardware being used to experimentally verify the projected long term operating capabilities of dry lubricated, VM cycle cryogenic refrigerators. It also describes the development and test of a wear resistant hardcoating that will be used to further increase the life of the hot rider ring.

### 1. DEVELOPMENT OF A WEAR RESISTANT HARDCOATING

The prime objective at the start of this program was to decrease the wear rate of the hot rider ring on the hot displacer. This ring was considered to be the life limiting component for a long life VM refrigerator operating in space. The wear surface of the liner against which the hot rider operates must also be carefully considered. It was decided that a hardcoating for this wear surface would provide the smooth finish and low friction interface needed to increase rider life. The next step would be to evaluate hardcoating processes and materials capable of operating at 1200°F to 1300°F.

Various methods of applying a thin hard coat of refractory material on the bore of hot cylinders and hot cylinder liners were explored. The two methods that appeared to be most feasible were sputtering and ion plating. The following selection criteria were used,

- The vendor must have had extensive experience with both coatings and deposition processes.
- The coating must remain homogeneous and free of crazing or spalling when the Inconel 718 substrate is heated to dull red (1200° to 1300°F) in air.
- At elevated temperature, the coating should withstand scratching by a hand-held steel tipped tool and resist penetration by a hard carbide tip.
- The coating process must be able to provide at least a 10,000-Å-thick layer on the hot zone of the cylinder or liner. The 77°K machines use the inside of the hot cylinder as a wear surface. This

# Contrails

part is closed at one end, and the cylinder aspect ratio, i. e., the diameter-to-length ratio, may be too small for the sputtering process to be effective. Source sputtering is essentially an LOS process, the shadowing and hollow cathode effects would present coverage problems in the bottom of a closed cylinder.

Three coatings were considered for this application:

1. Aluminum oxide,  $Al_2O_3$ ; ion plated
2. Chromium carbide,  $Cr_{23}C_6$ ; ion plated
3. Chromium disilicide,  $Cr_3Si_2$ ; sputter plated.

A number of test specimens was selectively coated in eight separate runs at the Endurex Company, Dallas, Texas. These specimens included 1.0 x 0.75 x 0.1 inch Inconel 718 coupons. Some were surface finished to 4 to 8 rms similar to actual hot cylinders and some were polished for interferometric thickness control. Other specimens included aluminum foil cylinders (Figure 9) with actual hot cylinder dimensions, an Inconel 718 sleeve with hot cylinder dimensions (Figure 10) and an actual 77<sup>o</sup>K hot cylinder (Figure 11). These specimens were selectively coated during eight separate runs and were examined by high temperature scratch tests, by optical and scanning photomicrography, and by energy dispersion x-ray (EDX) spectrometry. The test results follow.

1. None of the three coatings was completely penetrated by the hand-held carbide tip although the coatings were overstressed in the scratch paths. This stress did cause spalling under and immediately adjacent to the tip (see Figures 12 and 13). However, the spalling did not propagate into the unscratched areas.
2. EDX analysis showed that the material from the tool steel tip was transferred by smearing onto each hardcoat as shown in Figures 14 and 15. The refractory surfaces acted effectively as files by removing part of the steel tip.
3. All coatings appeared to perform better when thicker than 10,000 Å. This was particularly evident in the case of the ion plated alumina.

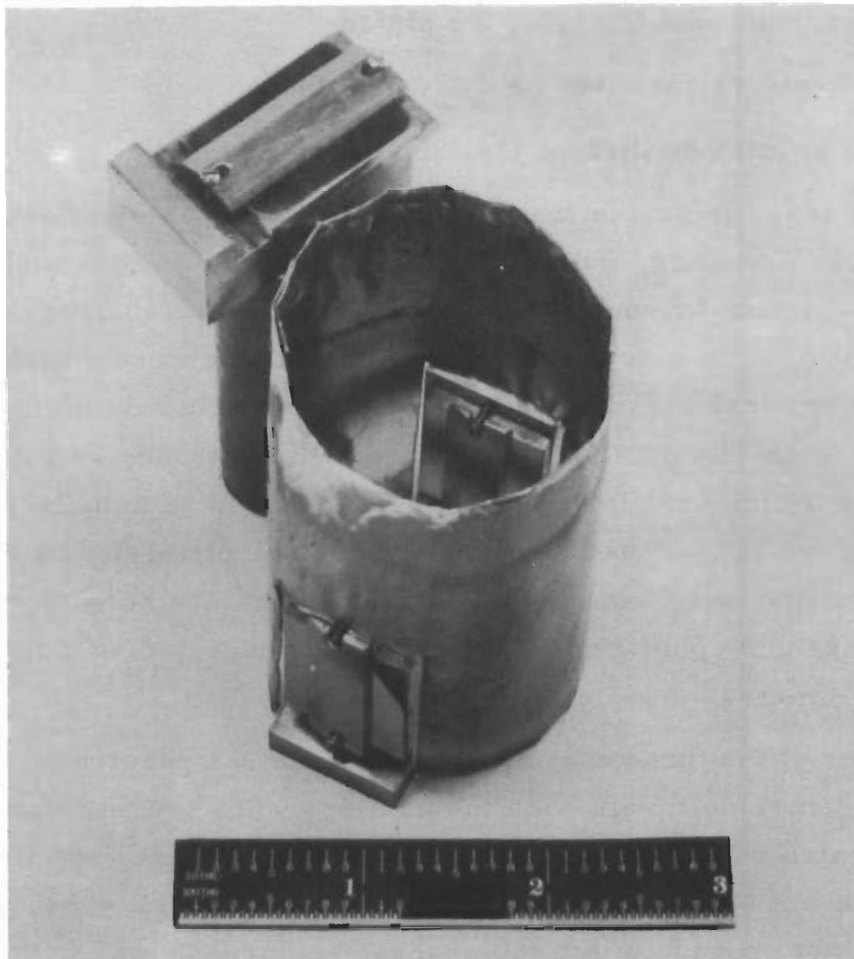

Figure 9. Aluminum foil test sleeve  
with sputtered  $\text{Cr}_3\text{Si}_2$   
(incomplete inside coverage)

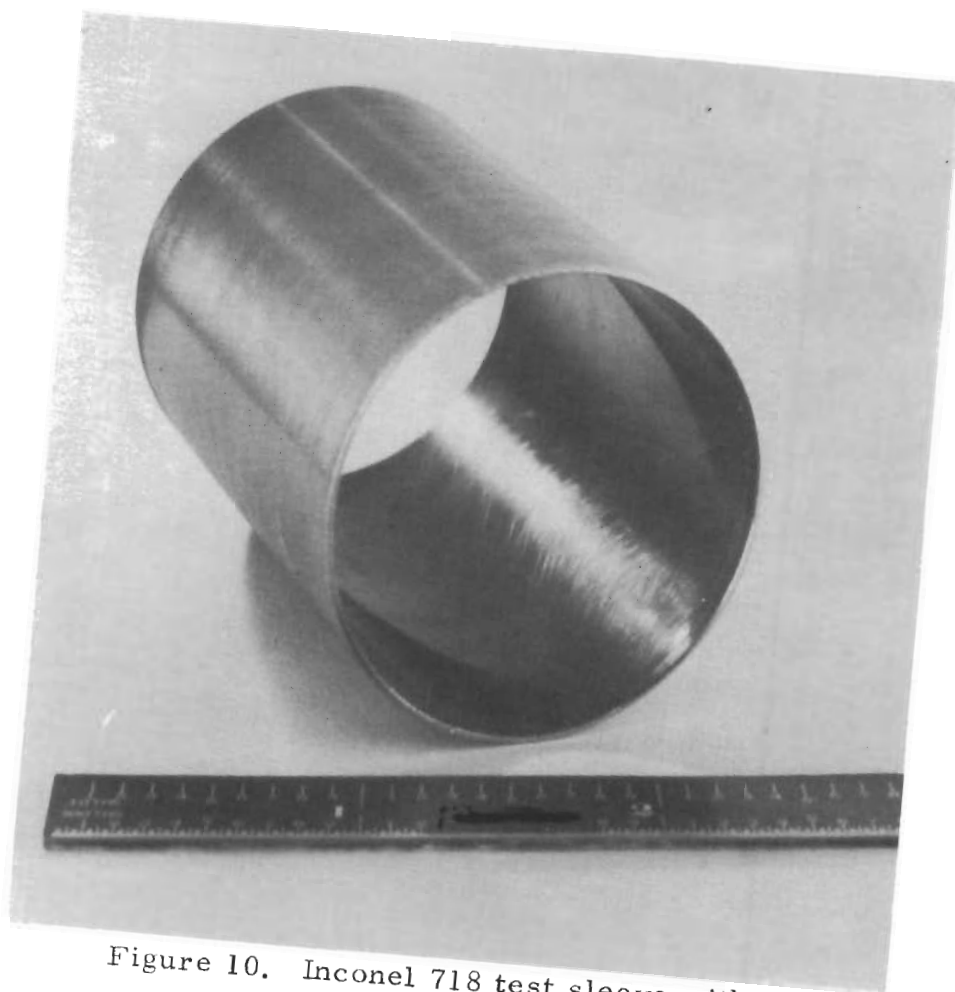

Figure 10. Inconel 718 test sleeve with ion plated  $Al_2O_3$  (complete inside coverage)



Figure 11. Liner test specimens



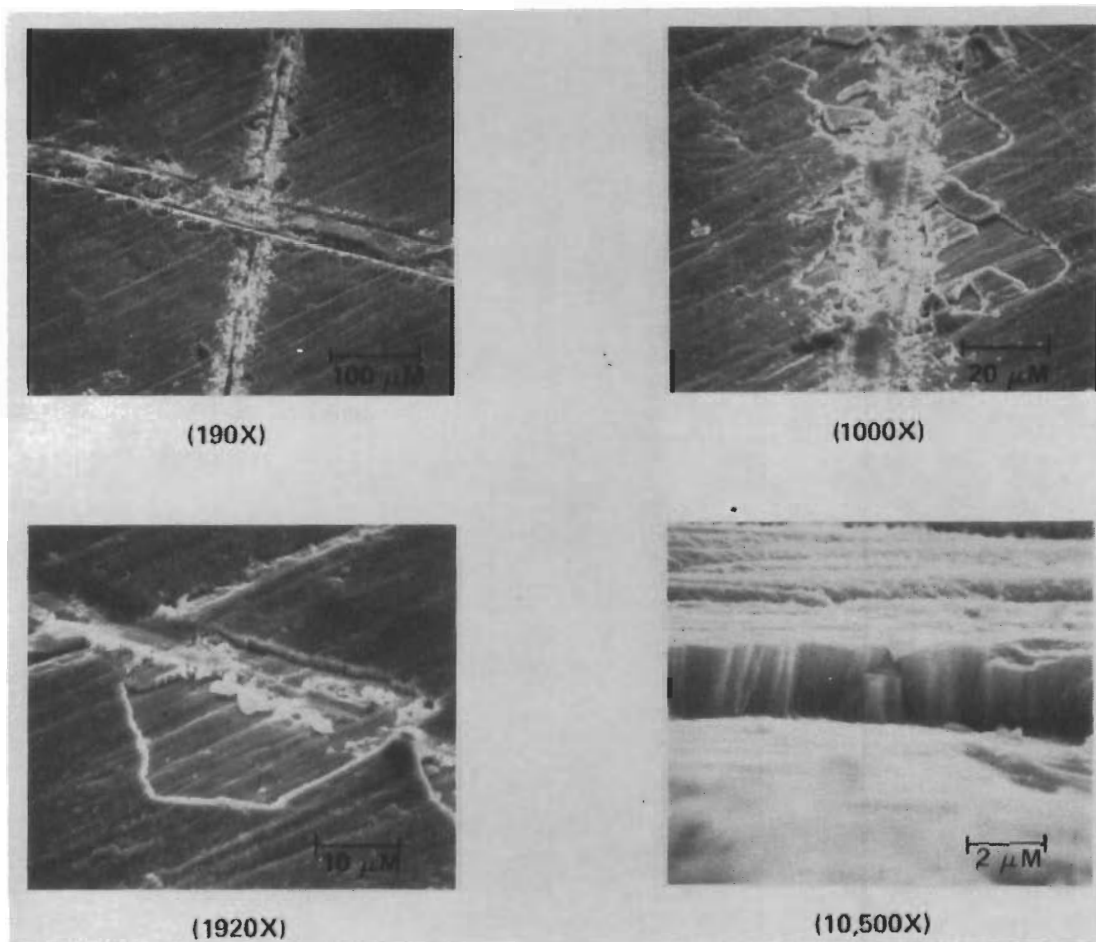

Figure 12. Sputtered  $\text{Cr}_3\text{Si}_2$  (lot 1);  
carbide tip scratch

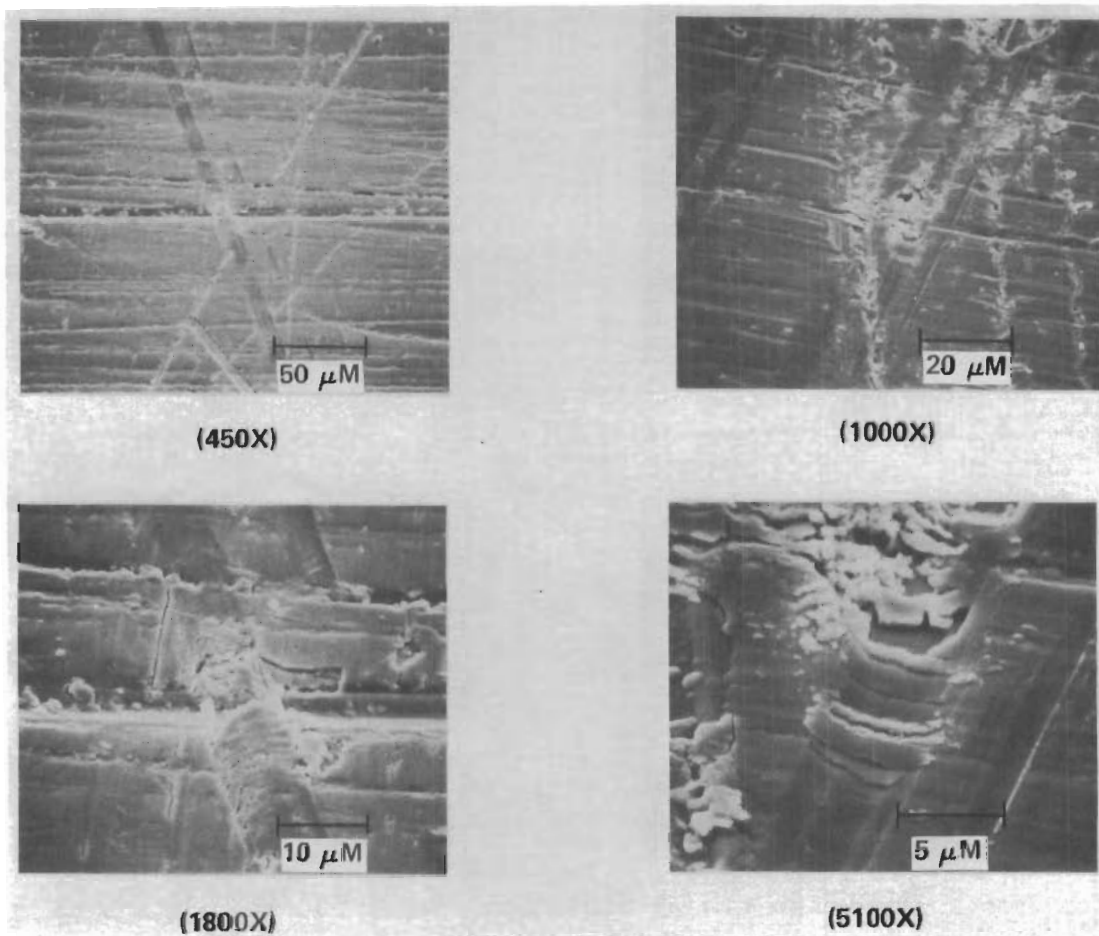

Figure 13. Ion plated  $\text{Cr}_{23}\text{C}_6$  (lot 5);  
carbide tip scratch

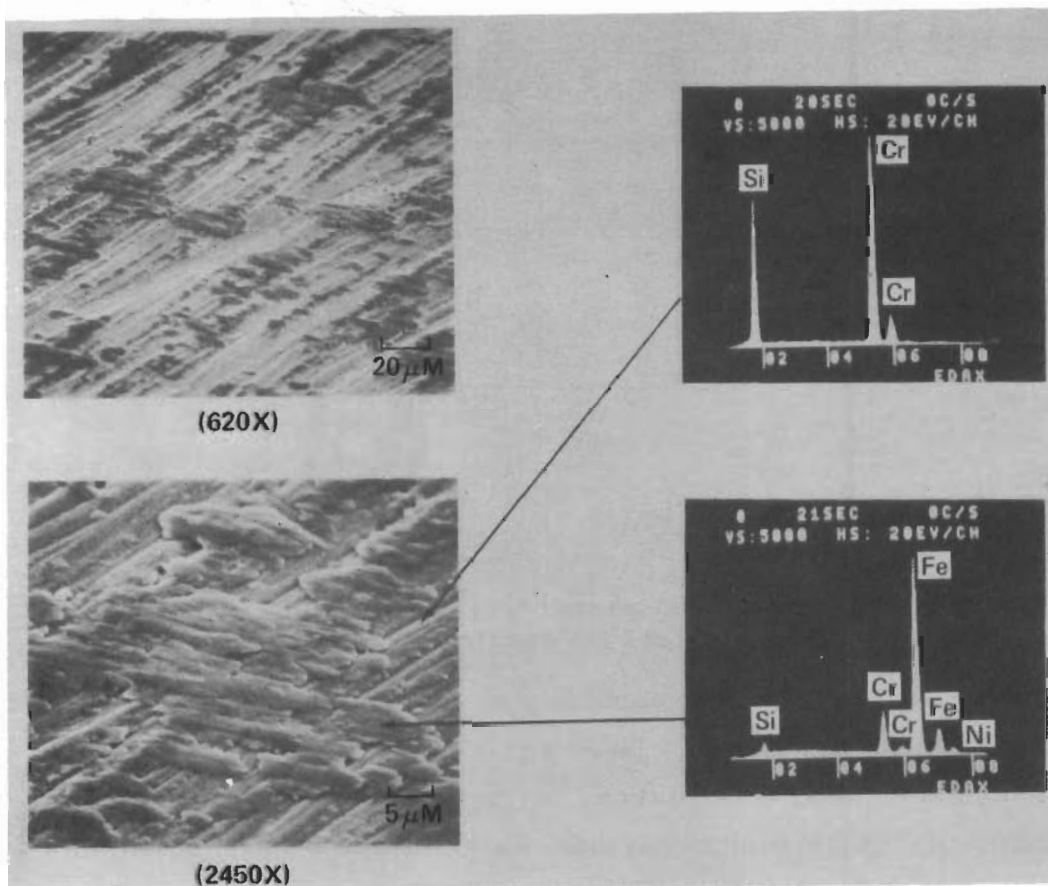

Figure 14. Sputtered  $\text{Cr}_3\text{Si}_2$  (lot 1); steel tip scratch

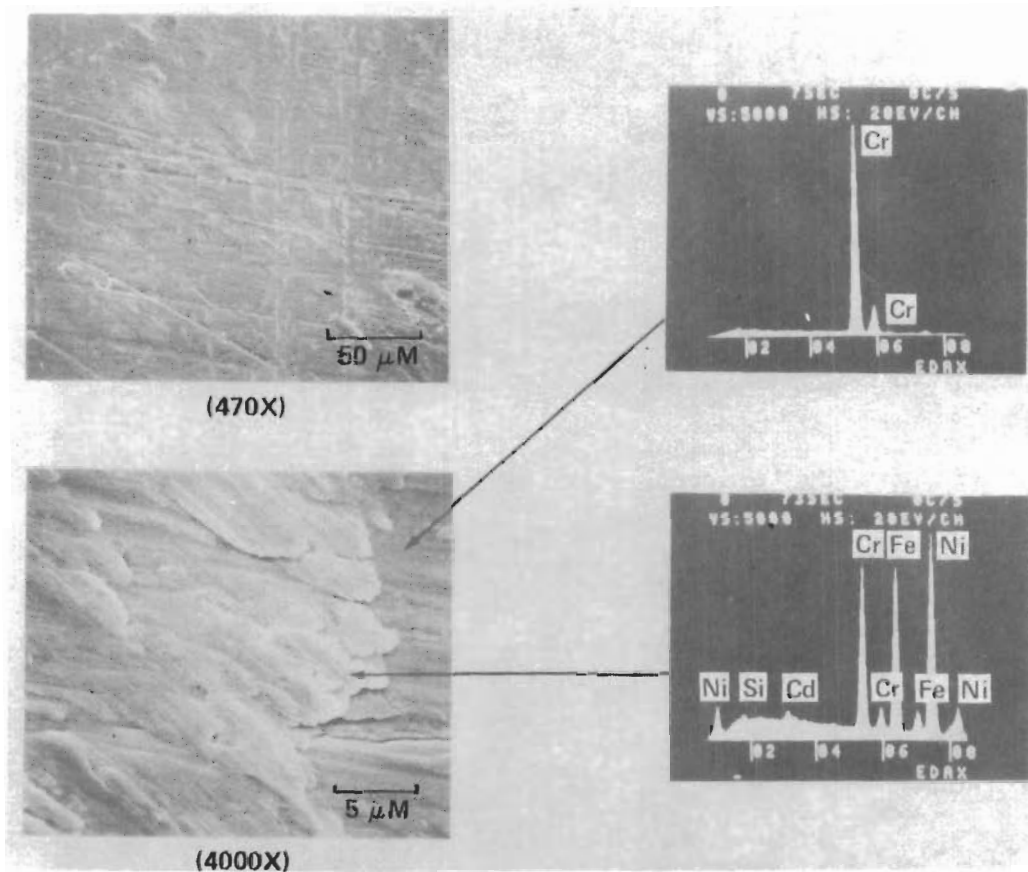

Figure 15. Ion plated  $\text{Cr}_{23}\text{C}_6$  (lot 5);  
steel tip scratch

4. Ion plating of chromium carbide was plagued with some crazing and repeatability problems. This was consistent with vendor experience. For this reason, or until better process control is achieved, the chromium carbide material has been shelved as a candidate hot cylinder coating.
  - Sputtering with chromium disilicide could not cover the bottom of the closed hot cylinder; regardless of the process time or the type of fixtures.
  - Ion plating with aluminum oxide provided good coverage in the cylinder hot zone with some of the fixture methods and the coating was homogeneous, dense, and tough to penetrate. Also

the Endurex Company has the most experience in applying aluminum oxide by ion plating. For these reasons this process was selected for the prime cylinder treatment.

## A. Measuring Surface Adhesion of Alumina

It was decided at this time that a method of measuring the surface adhesion of the alumina to the Inconel substrate must be developed. A test fixture was constructed that duplicated the weight and approximate diameter of the hot displacer. The fixture was designed to hold either a rider ring or an aluminum ring with a piece of sandpaper attached to it.

As the fixture is rubbed back and forth in the bore of the cylinder, 100-grit sandpaper will quickly wear its way through the alumina to the substrate if the adhesion is unsatisfactory. With proper adhesion the sandpaper will scratch the surface, but will not break through.

## B. Procedure for Ion Plating as Developed to Date

### Cleaning

1. The cylinder is first degreased with trichloroethylene and acetone to remove the oils that accumulate during the machining and handling operations. Figure 16 shows a cylinder, on the left, ready to be plated.
2. The bore of the cylinder is lightly scrubbed with Ajax cleanser (unchlorinated); a small amount of water and a lint free cloth are used. The bore is thoroughly rinsed under flowing water and then ultrasonically rinsed in first hot water and then rinsed two more times in cold water for a total of nine minutes to remove any remaining grains of cleaner. At this point the cylinders must be clean to a water break condition. The cylinders are then rinsed twice with deionized water.
3. Water is removed with an acetone rinse and then boiling acetone with ultrasonic agitation.
4. A final freon rinse is given just before the cylinder is placed in the ion plating vacuum chamber.





Figure 16. Cylinder ready to be plated  
(73-19400)

Physical Set-up

1. The plating source is a commercial tungsten basket mounted in the system at an angle of 30 to 45 degrees from the vertical. A charge of pure alumina is placed in the basket, the system is pumped down (vacuum), and the filament power is increased to a level where the source just glows. This is done to outgas the source.
2. Next, the cylinder is placed on the rotating table with the source mounted in a stationary position in the center. The source is adjusted vertically depending on where the thickest coating is desired. Experience shows the maximum coating build-up of alumina is in an area directly opposite and extending perpendicularly



outward in all directions from the lower three quarters of the basket. Then extending from the tip of the basket downward about one inch, the coating gradually tapers down to approximately one-half the maximum thickness.

## Plating Surface

1. Before it is plated, the cylinder is subjected to 15 to 20 minutes of backsputtering in an argon atmosphere with the pressure level in the range of  $2$  to  $5 \times 10^{-4}$  torr. This backsputtering is a final cleaning operation to remove the surface oxides.
2. Sufficient oxygen is bled into the system to obtain a pressure level of  $5 \times 10^{-6}$  torr, this level is maintained during the entire plating process. Twelve hundred volts rms of bias power is applied to the cylinder, while filament power to the source is rapidly increased and is kept at as high a rate as possible for 2 to 2.5 minutes. Care must be exercised here; if the rate is too high, the alumina will melt too fast and will drop out of the source and spatter. If the rate is not high enough the coating adhesion will be poor.
3. After plating, the cylinder is permitted to gradually cool down in the chamber for 1 to 2 hours at a vacuum level of not more than  $10^{-4}$  torr.

## C. Rework of Ion Plated Materials

If rework is necessary, the alumina can be etched off in a hot solution of ethylene diamine tetra-acetic acid. After the alumina is completely removed, the cylinder is reworked in accordance with these instructions starting with step 1 of the cleaning procedure.

## 2. REFURBISHMENT OF GFE 77°K VM COOLERS

The three 77°K VM coolers that were furnished by the government were refurbished during the early phase of this program. These coolers are identified by Hughes Aircraft Company drawing X3243002-100; a typical unit is shown in Figure 17.

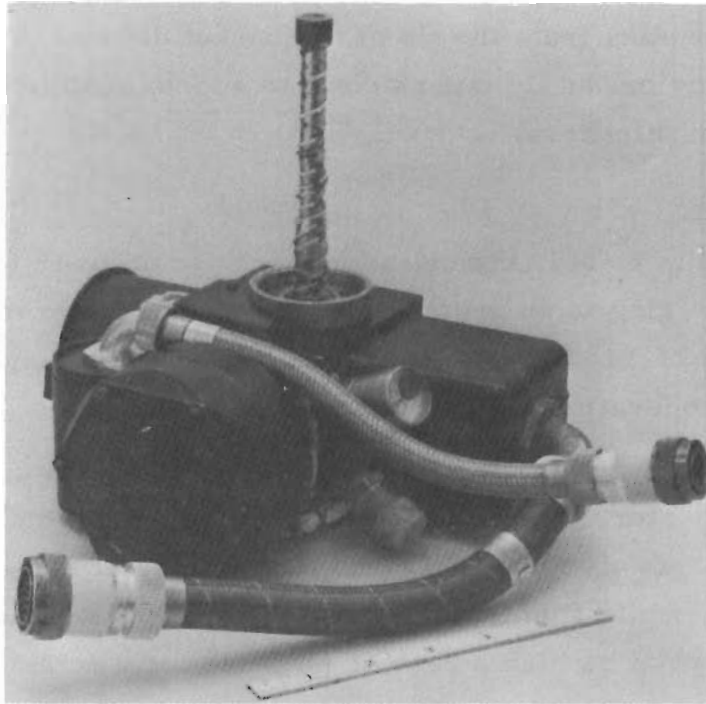

Figure 17. 77°K VM cooler refurbished for wear test program (71-7232)

Incremental tests, each lasting three months, are being conducted to evaluate the endurance capabilities and to aid in the selection of life limiting components such as rider rings, dynamic seals, and bearings. The heaters and the hot cylinder temperature sensors were also considered for checkout. However, since these are GFE coolers with the original heaters already brazed to the cylinder, x-rays and other preassembly measurements could not be taken. Only heater power, temperature, and operating hours are being recorded. Some of the original platinum resistance sensors were shorted or open when the units were received. Based on cost, delivery, and the ease of retrofitting, chromel-alumel thermocouples were installed for hot end temperature control. These thermocouples can be recalibrated at the conclusion of the wear rate test program if required.

The candidate hot rider rings were carefully weighed and measured before they were installed in each test cooler. After each incremental test phase,

the rider rings are reweighed and, if necessary, remeasured, before being reinstalled and tested further. After the tests of any particular hot rider ring are completed, wear projection will be made on the basis of the test geometry, test duration, and wear measurement.

An unsuccessful attempt was made to hardcoat the inner hot cylinder wall of two of the three 77°K VM coolers. The theory was to select the best rider/liner friction couple. However, the set-up fixturing and the technique to ion plate the bottom end of a small diameter, closed end cylinder has some process limitations; the results were cylinders with very poor coating thickness, adhesion, and surface finish. The two cylinders were cleaned and the decision was made to test all hot rider rings against the original bare Inconel 718 wall.

Earlier tests made with the previously used GFE coolers indicated that the Inconel 718 hot cylinder material had significantly softened from high temperature exposure and were not as strong. In addition, when the inner wall was cleaned, the nominal wall thickness was reduced from 0.026 to 0.024 inch. Therefore, the following changes were made to minimize the possibility of creep or rupture of the hot cylinders during the test period:

- The charge pressure was reduced in order to minimize stresses and limit creep to less than 0.1 percent in 10,000 hours.
- The control temperature was set at 1100°F to compensate for the estimated 150°F temperature drop between the hot cylinder heater area and the temperature sensor.

In addition to measuring the inside diameter and roundness of the hot cylinder, the surface finish of the areas in contact with the rider ring and seal are being measured with a surfanalyzer after each incremental test phase.

The dynamic seals and riders operating at room temperature and below for these 77°K coolers are of the original design. Initially, seals of rulon-J material were used on the cold displacers because of its availability and for its

performance information value. Seals in all three coolers were ultimately replaced with standard 15-percent glass loaded teflon seals. The ambient riders on the cold end displacer, although worn to some extent from previous use, were measured in order that relative wear might be compared at the end of the test program. The riders are also fabricated of 15-percent glass loaded teflon. Experience indicates that the graphite filled teflon dynamic seal on the hot end piston will not wear as well as the other materials. However, this is the standard seal material for the 77°K VM coolers, and it will be tested for its performance information value.

Originally, each 77°K VM cooler was to have had new bearings installed before its initial incremental test. Because of a delay in delivery of the bearings, the original bearings were cleaned and reinstalled. The bearings used are a duplex pair at the crankshaft and a single and duplex pair at the motor assembly. Torque tests were made of all bearings when they were new and will be repeated for comparison at the end of each or final incremental test period. At the conclusion of the test program, each bearing will be analyzed and evaluated in Hughes bearing laboratory.

### 3. ACCELERATED WEAR TEST MODULE

High capacity VM refrigerators for space based applications are, of necessity, rather large when compared to typical airborne units. The space based refrigerator is roughly ten times larger and operates at approximately one-third the cyclic speed of airborne units.

One approach to developing highly reliable space refrigeration equipment is to conduct accelerated wear tests by using equipment that closely simulates an actual system. The accelerated wear test module is intended to accomplish this task.

In order to simulate as closely as possible actual VM space refrigeration equipment, it was decided to use the same hot cylinder/crankcase design and materials as the Hi Cap spaceborne refrigerator (see Figure 18) developed under Air Force contract F33615-71-C-1029. In addition it was decided to



Figure 18. Hi Cap spaceborne VM refrigeration system (4S14027)

increase the operating speed as much as possible while limiting drive forces and heater power to those values representative of the actual Hi Cap refrigerator. The cold displacer/cold cylinder assembly was not included as part of the test module since it would further complicate the mechanical design and limit the test speed and would include cold end components that did not appreciably limit the useful life of the refrigerator.

A test module design analysis was conducted to define the mechanical design modification necessary to convert the hot cylinder/crankcase design of the Hi Cap refrigerator into an accelerated wear test module. The hot displacers and hot cylinders would be identical to those in the Hi Cap refrigerator. The design goal then would be to define a test module capable of operating at a speed of 900 rpm, three times the Hi Cap speed, while



limiting the hot displacer wrist pin forces and heater power to 50 lb and 1800 watts, respectively, which is consistent with the existing mechanical design.

The basic concept was to increase operating speed without increasing wrist pin force or heater power requirements by reducing the pressure drop across the hot displacer. This would compensate for the increased displacer inertia forces experienced at high speeds. The pressure drop would be reduced by modifying the hot regenerator matrix and increasing the flow area in the annular regenerators. This modification would reduce regenerator efficiency, but the heater power could be maintained at acceptable levels by decreasing the helium gas charge pressure.

To accomplish the above goals, most of the thermodynamic design analysis was performed with a modified version of the computer program used in the original design of the Hi Cap VM refrigerator<sup>45</sup>. The computer program was modified to reflect the removal of the cold displacer/cold cylinder assembly and then used to evaluate hot regenerator designs and to define heater power requirements at reduced working pressures and high speeds. Pressure drops across the heat exchangers and parts were calculated by applying the Darcey formula.

The inertia force acting at the wrist pin was calculated by the following relation as derived in reference 46.

$$F = MRW^2(\cos \theta + R/L \cos 2\theta)$$

where

- F = inertia force
- M = mass of displacer
- W = angular speed
- $\theta$  = crank angle
- L = length of link
- R = crank radius



# Contrails

The sinusoidal pressure force at the wrist pin is defined by

$$F = 1.57 \Delta P A \sin \theta$$

where

$\Delta P$  = average pressure drop across displacer (calculate by Darcey formula)

A = cross sectional area of displacer

$\theta$  = crank angle

The seal friction force acting on the displacer is the same as in the Hi Cap refrigerator. With the forces defined, the motor torque was determined graphically from a layout of the crank and connecting rod mechanism. The results of the analysis indicated that a tube regenerator matrix would be needed in order to reduce the hot regenerator pressure drop and achieve a maximum speed of 750 rpm. This speed is less than the 900 rpm desired, but is limited by the maximum wrist pin force. The largest tube size possible was determined to be 0.180 inches OD; a 0.150-inch ID was also selected.

The preliminary mechanical layout used an 0.180-inch OD tube as the hot regenerator matrix. It was immediately ascertained that the OD of the tube could be no more than 0.165 inch if it was to fit the existing Hi Cap hot regenerator envelope.

The computer analysis was redone by using 0.165-inch OD tubing as the baseline. The analysis was also refined to maximize speed by further reducing charge pressure in the test module. The results of this analysis indicate that the maximum operating speed could be 780 rpm. Maximum speed was again limited by the combined inertia, pressure, and friction forces acting on the wrist pin. As illustrated in Figure 19, at 780 rpm, the peak wrist pin bearing load is approximately 50 lb. It is seen that the peak wrist pin load occurs when the displacer is near the top or bottom dead center (crank angle  $30^\circ$  past dead center). This represents a  $60^\circ$  phase difference when compared to the Hi Cap unit. The test module favors the Bendix flexure pivot since the pivot has maximum strength at the dead center positions.

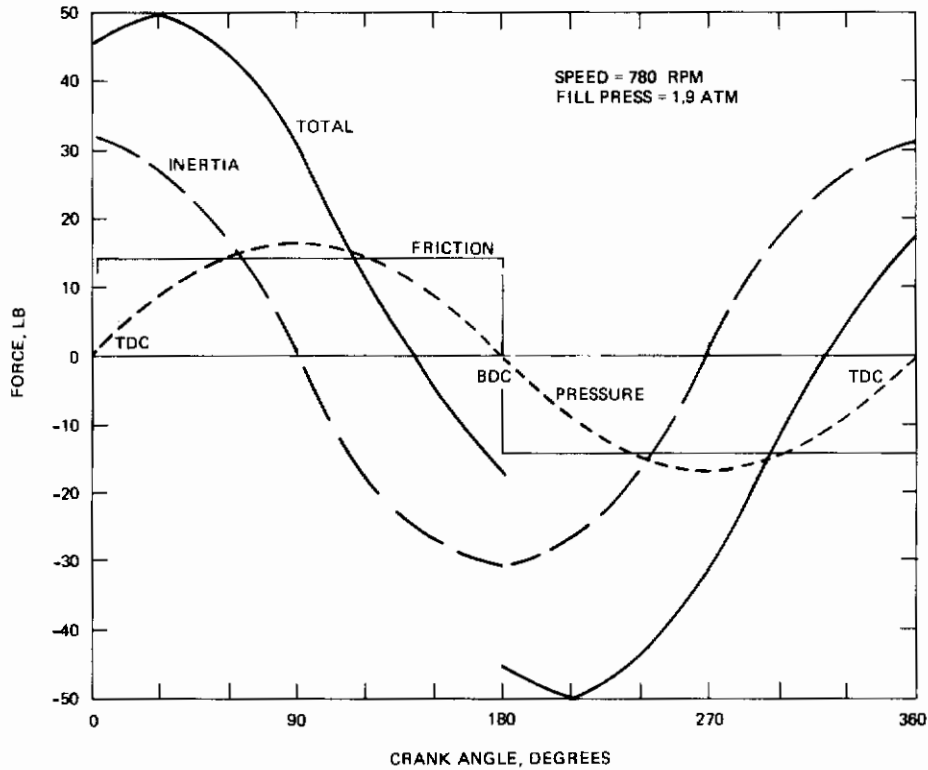

Figure 19. Summation of wrist pin forces as a function of crank angle

The peak motor torque at 780 rpm is 331 in-oz, and the mean torque is 172 in-oz. Required torque is presented as a function of crank angle in Figure 20.

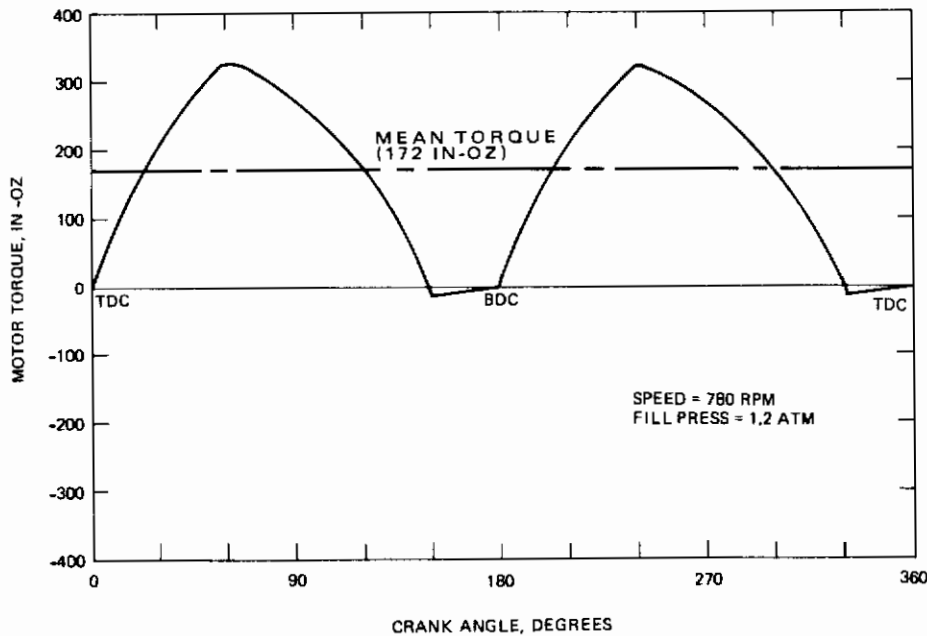

Figure 20. Motor torque as a function of crank angle

The following modifications were recommended to achieve the above results:

- Increase the crankcase volume to 340 cc to provide the volumetric relationship needed to produce pressure ratios typical of VM refrigerators (ratio = 1.3).
- Decrease the fill pressure to approximately 1.9 atmospheres absolute. The lower pressure is required to keep heater power requirements from becoming excessive as a result of the less efficient regenerator matrix and increased operating speeds. A working pressure below 2 atmospheres also reduces the number of seals that the external motor needs.
- Replace the regenerator matrix with standard 0.165-inch OD, 0.135-inch ID stainless steel tubing. The new matrix reduces the regenerator pressure drop to negligible levels and is sized to fit into the existing regenerator envelope.

The tube regenerator matrix was selected to reduce regenerator pressure drop since the ratio of friction factor to Colburn modulus is approximately one third that of other matrices. Although several tube sizes other than the 0.165-inch OD tube are satisfactory for the test module, the 0.165-inch diameter is convenient since it best fits into the existing regenerator envelope.

Packing sphere matrices were also studied, and it was concluded that a minimum ball diameter of approximately 0.10 inch would be required at 780 rpm if maximum packing density is assumed. However, because of the relatively small regenerator envelope, it is uncertain, without further analysis, what packing density would be realized with that large a ball and how regenerator performance would be affected.

Tables 5 through 7 show the results of the analysis of hot displacer forces.

As discussed earlier, one approach to accelerated wear testing is to use equipment that closely simulates the actual system. It was also decided

TABLE 5. SUMMARY OF HOT DISPLACER PRESSURE DROP AND SEAL FORCES

		Average, lb	Peak, lb
Pressure drop across hot heat exchanger	} Pressure Curve	5.0	7.8
Pressure drop across hot ports		0.3	0.5
Pressure drop across regenerator		0.04	0.06
Pressure drop across ambient ports		0.6	0.9
Pressure drop across ambient heat exchanger		4.8	7.6
Rider ring and seal force	} Friction Curve	14.0	14.0
Total		24.74	30.86

TABLE 6. TEST MODULE DESIGN PARAMETERS

Minimum pressure (absolute), atm	2.32
Maximum pressure (absolute), atm	3.04
Fill pressure (absolute), atm	1.9
Cycling rate, rpm	780
Crankcase volume, cc	340
Hot end temperature, °K	920
Heat rejection temperature, °K	340
Hot heat exchanger temperature, °K	940

TABLE 7. POWER SUMMARY FOR EACH HOT CYLINDER

Source	Power, watts
Regenerator heat	212
Aerodynamic friction	0,062
Cylinder conduction	91
Displacer conduction	79
Piston internal	16
Linear conduction	55
Shuttle	55
Regenerator conduction	52
Lead wires	50
Pumping	1
Insulation	<u>26</u>
Total power for each hot cylinder	637,062
Total heater power to test module =	1274

to use the same hot cylinder/crankcase design and their materials (see Figure 21) as developed under Air Force Contract F33615-71-C-1029. With this as a basis, the mechanical design of the accelerated test module was created.

The cold cylinder components shown in Figure 21 will not be needed for the test module. At the lower left of the figure is a cross section of the crankcase housing. Figure 5 earlier depicted the details of the hot end assembly; Figure 22 is a cross sectional view of the hot displacer link drive assembly. The motor stator and rotor and the cold displacer linkage will not be used. Instead, a new counterweight to balance the basic drive mechanism without the cold displacer linkage will be included.

Figures 23 and 24 are two views of the final configuration of the test module. Its main features include an external V-belt variable speed drive mounted on a special test cover that supports the outboard drive and forms a helium gas closure with the crankcase. The crankcase and hot cylinders are the same as those in the basic Hi Cap refrigerator (see Figure 21).

During the course of designing the external drive for the test module, it was decided to increase the load capacity of the flexure pivot shown in Figure 5 of the hot end assembly. This decision was made for two reasons. The design analysis showed that the flexure pivot with its load capacity was the speed limiting component; also life data on flexure pivots being used in actual earlier test refrigerators indicated that it may be a marginal component.

As can be seen in Figure 23, the cold cylinder port of the Hi Cap crankcase is blanked off with a cover to form the last remaining gas seal element of the test module. At the time of this report, the test module is in the final stages of fabrication and assembly.

#### 4. HI CAP VM REFRIGERATORS S/N 2

A spare Hi Cap refrigeration system developed under Air Force contract F33615-71-C-1029 was furnished as GFE for endurance testing on this program. Figure 25 shows this system, and Air Force report AFFDL-TR-75-108 describes in detail its physical aspects.



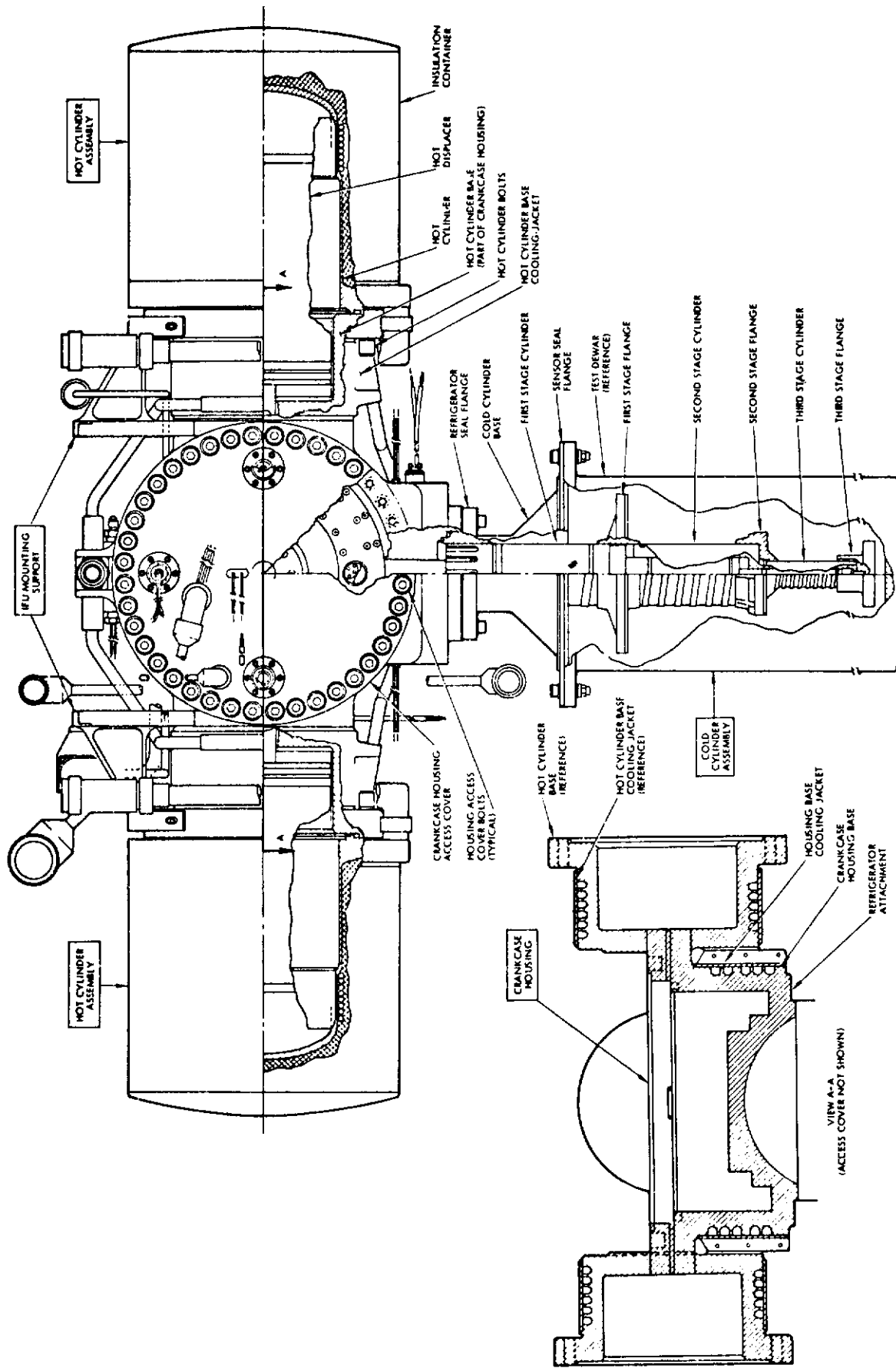

Figure 21. Location of components on basic Hi Cap refrigerator

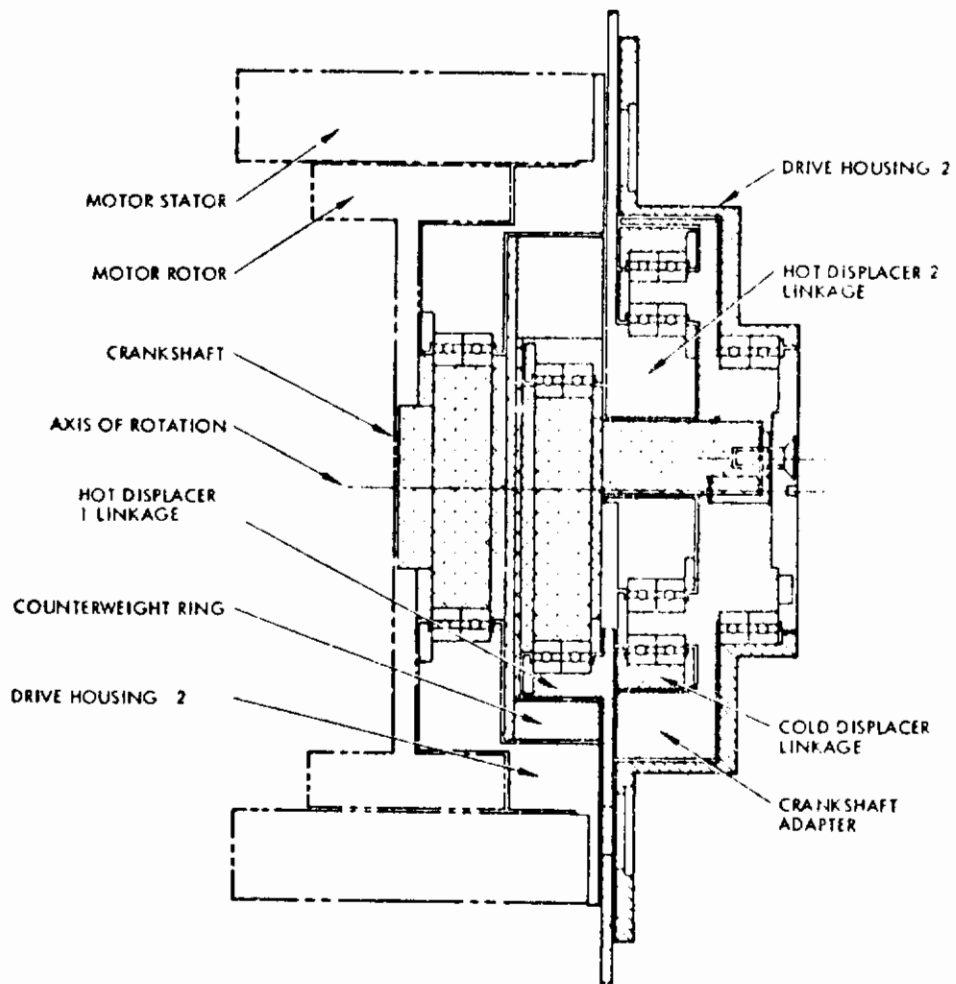

Figure 22. Cross sectional view of refrigerator drive assembly

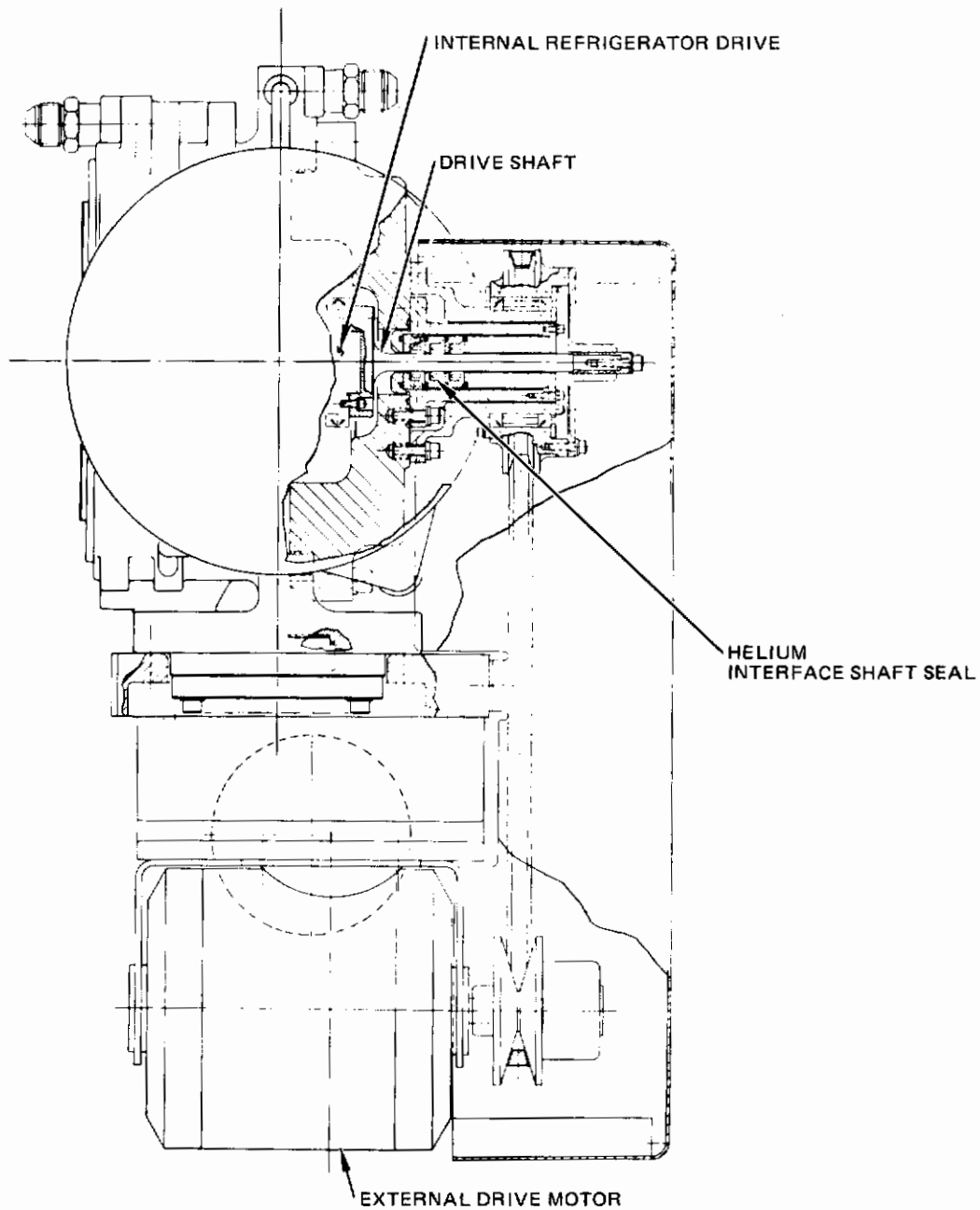

Figure 23. Test module for VM cooler wear rate program

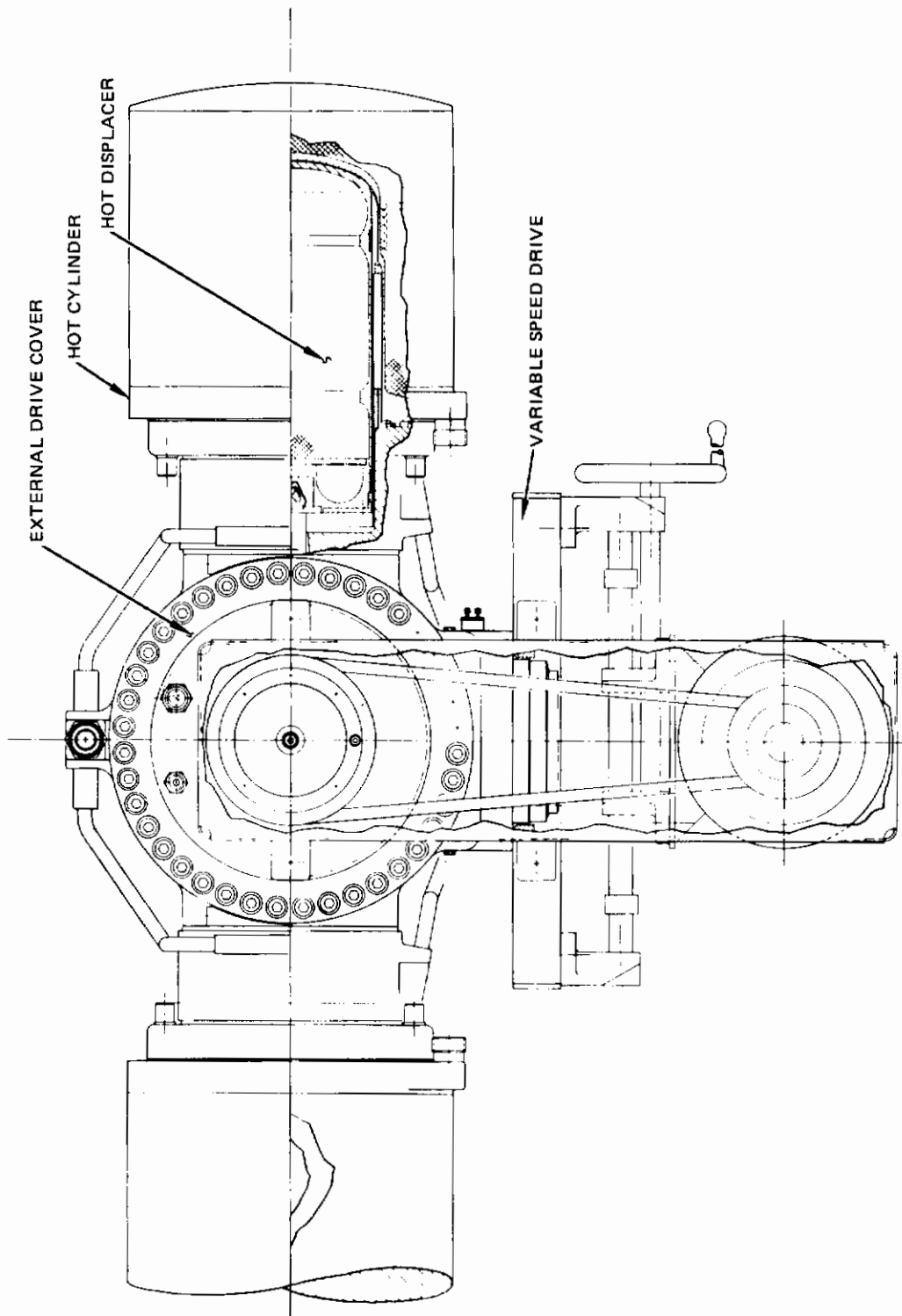

Figure 24. Test module for VM cooler wear rate program

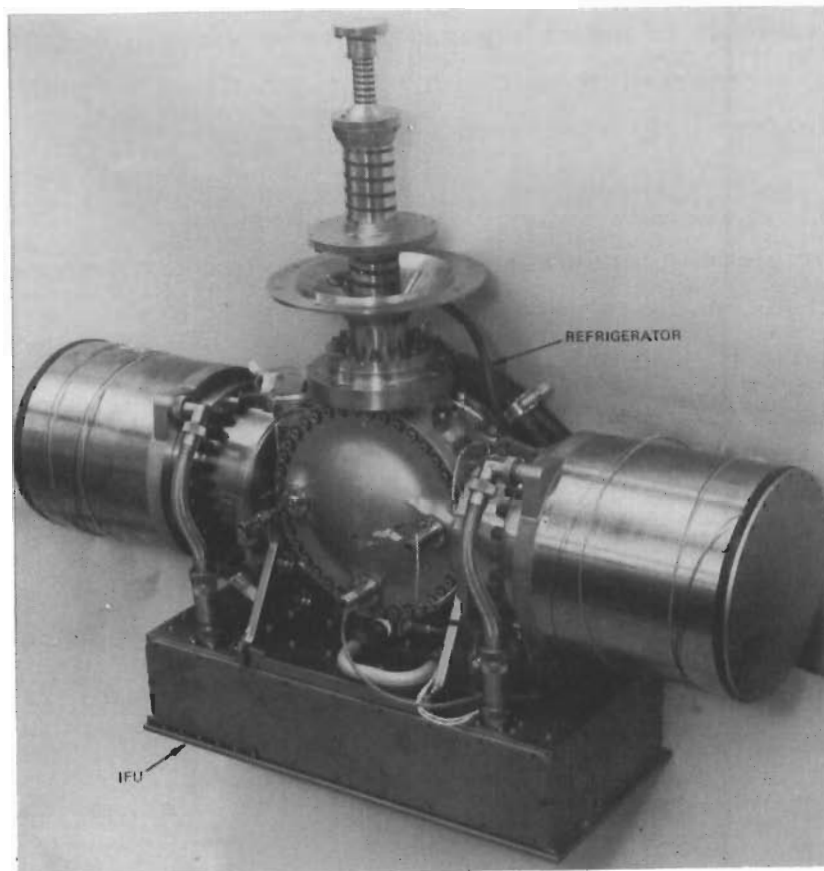

Figure 25. Hi Cap long life VM refrigeration system for space applications (72-21547)

This refrigerator is being used to ascertain the operating life of a space VM refrigerator. As discussed in Section 3, this refrigerator will be tested over four incremental periods of 2500 hours each to obtain life data on components in the refrigerator; this data will be extrapolated to predict operating life expectancy.

Before the first incremental test was begun, new hot displacer hot rider rings were fabricated from the most promising material (namely Boeing self-lubricating Compact 6-84-1), evaluated in the 77°K VM screening tests to date. It was also decided to operate this new rider material against a hard coated surface, which was selected to be aluminum oxide,  $Al_2O_3$ , ion plated on inconel sleeve inserts installed in the hot cylinder liners.

The rider rings as well as other critical components were measured before final assembly of the refrigerator for the start of endurance testing. Test results are reported in Section 5. The details of ion plating to achieve a hard wear surface were discussed in Section 2.

## 5. SPECIAL TEST EQUIPMENT

Two major pieces (consoles) of STE are needed for the wear rate test program. The first console is used in testing three 77°K VM coolers; the second is used with either a Hi Cap type VM cooler or the accelerated test module. In both cases, this STE provides services to the test items and manages data resulting from the effort. This STE is described below.

### A. 77°K Test Console

The 77°K VM refrigerator test program requires a test and instrumentation control system with the following capabilities and specifications:

- Must operate three systems (77°K VM refrigerators) simultaneously, 24 hours a day, seven days a week.
- Automatically shut down for equipment failures; isolate faults or failures.
- Automatically acquire, calculate, and compare data
- Operate in three modes
  - Manual for troubleshooting
  - Semiautomatic for special tests
  - Automatic for normal operation
- Be low cost
- Be easy to program
- Be ease to operate

The following sections briefly describe the 77°K STE, which meets these requirements. This test system has been in operation over 6000 hours since final checkout. Figure 26 is a photograph of the test console.



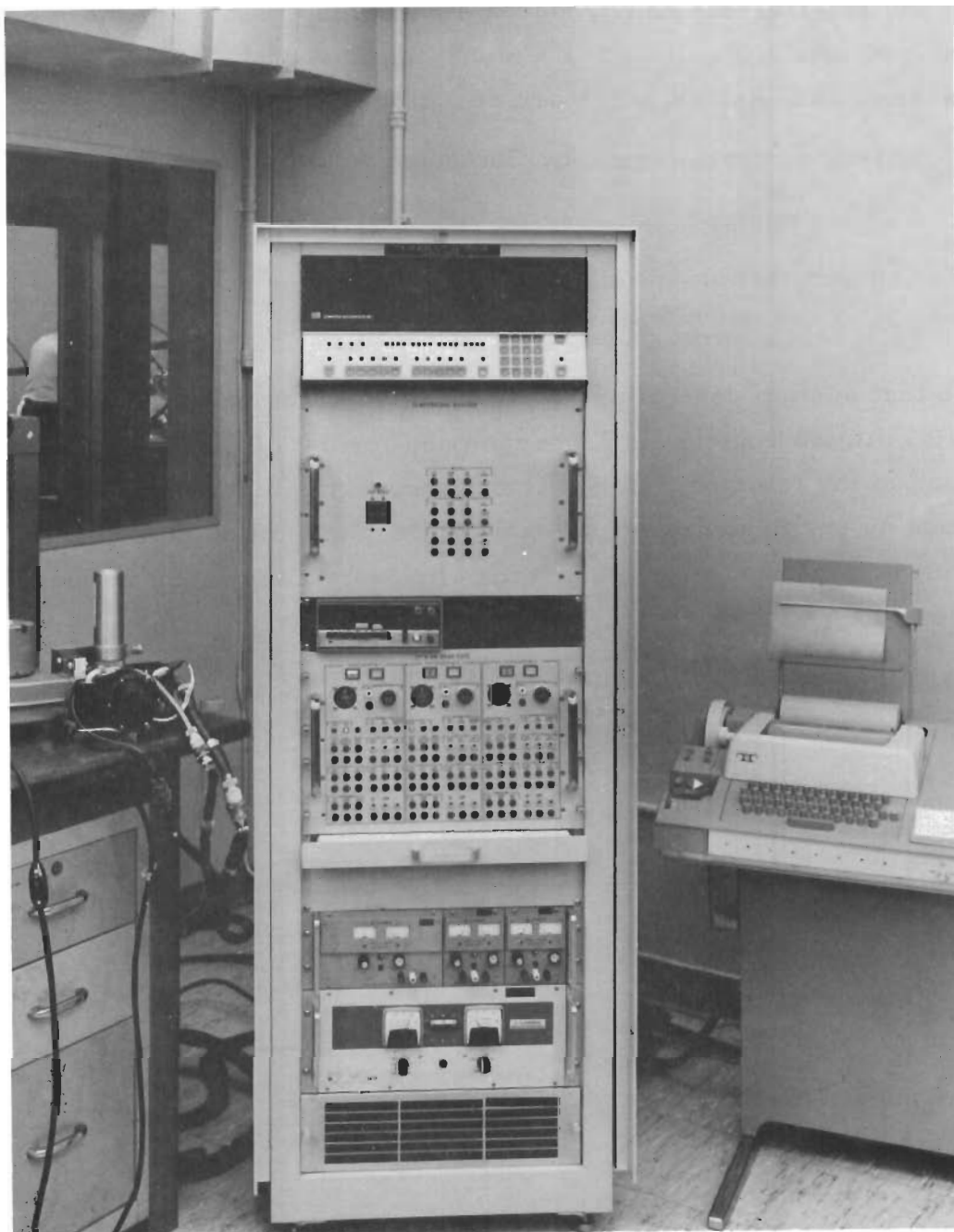

Figure 26. 77°K test console (76-43015)

The test station (test and instrumentation control system) simultaneously operates three 77°K VM refrigerators. It monitors various operating parameters of the refrigerator and produces a hard copy readout of these parameters on command. Figure 27 is a block diagram of the station showing the major system components, which are described below,

- LSI-02 computer made by Computer Automation
- ASR-33 teletype
- Temperature monitor panel
- 77°K test control panel

The test system control processing unit is a Computer Automation LSI-2/10G minicomputer. It processes and formats the refrigerator data for output on the teletype. In addition, it performs many housekeeping tasks such as keeping track of the time of day, outputting data automatically at commanded intervals, keeping track of power failures and refrigerator

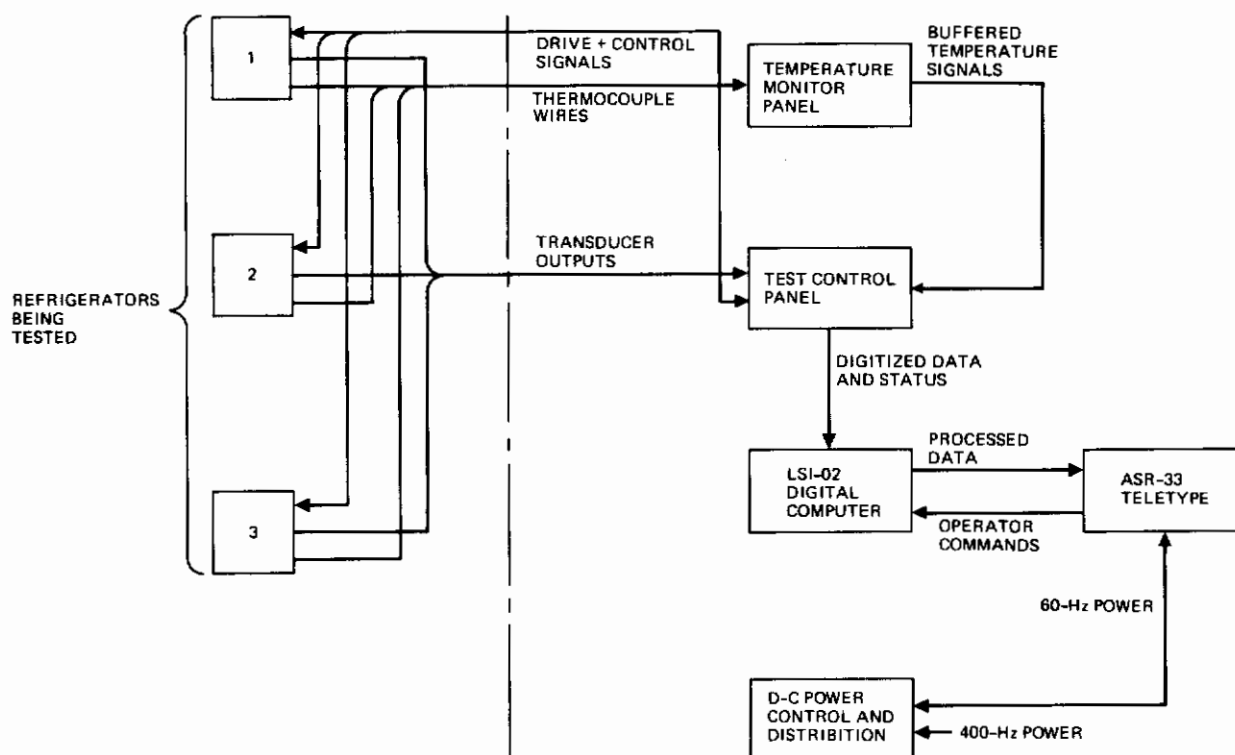

Figure 27. Block diagram of test control and instrumentation system

faults that may occur, and decoding and responding to commands from the human operator input via the teletype.

The teletype is a modified ASR-33. It outputs written data and interfaces the operator with the test system. Additionally, it produces a hard copy readout of parameters or faults on command from the computer. Figure 28 is a sample data printout.

The temperature monitor panel buffers and scales thermocouple signals from the refrigerators being tested. Included in this panel are a sealed ice bath (to provide a service free reference junction temperature), chromel-alumel and copper-constantin wiring to maintain thermocouple integrity, and low drift d-c amplifiers to provide buffered temperature signals to the test control panel.

The 77°K test control panel is the interface between the refrigerators being tested and the computer. This panel contains

- a temperature controller for each refrigerator hot cylinder
- a motor inverter for each refrigerator
- a device for buffering and scaling transducer signals from each refrigerator
- a multiplexer to switch the various signals from each refrigerator onto the input to the A/D converter
- An A/D converter to digitize the refrigerator data for input to the computer
- a computer interface that decodes computer commands and drives the multiplexer to the channel selected by the computer and transmits the digitized data to the computer.

The test station software consists of a machine language source tape containing approximately 2000 binary words. Each word is 16 bits long. This source tape is the result of linking a number of shorter programs written in Omega II assembly language and assembled by using the LSI-02 computer and the Omega II assembly program. Figures 29 through 31 are flow diagrams of the program.

# Contrails

## 77 DG K WEAR RATE PROGRAM

ELAPSED TIME IN HOURS +1224.7

REFRIG. NO	1	2	3	UNITS
INST PRS	+00283.	+00235.	+00340.	PSI
INST PRS	+00275.	+00235.	+00340.	PSI
INST PRS	+00266.	+00235.	+00340.	PSI
INST PRS	+00258.	+00235.	+00340.	PSI
INST PRS	+00252.	+00235.	+00339.	PSI
INST PRS	+00247.	+00236.	+00340.	PSI
INST PRS	+00242.	+00236.	+00340.	PSI
INST PRS	+00240.	+00235.	+00340.	PSI
INST PRS	+00239.	+00235.	+00339.	PSI
INST PRS	+00240.	+00235.	+00340.	PSI
INST PRS	+00243.	+00235.	+00340.	PSI
INST PRS	+00248.	+00235.	+00340.	PSI
INST PRS	+00254.	+00235.	+00340.	PSI
INST PRS	+00261.	+00235.	+00340.	PSI
INST PRS	+00270.	+00235.	+00340.	PSI
INST PRS	+00279.	+00235.	+00340.	PSI
INST PRS	+00288.	+00235.	+00340.	PSI
INST PRS	+00298.	+00235.	+00340.	PSI
INST PRS	+00306.	+00235.	+00340.	PSI
INST PRS	+00313.	+00235.	+00339.	PSI
INST PRS	+00318.	+00236.	+00340.	PSI
INST PRS	+00322.	+00236.	+00340.	PSI
INST PRS	+00323.	+00235.	+00340.	PSI
INST PRS	+00323.	+00236.	+00339.	PSI
INST PRS	+00321.	+00235.	+00340.	PSI
INST PRS	+00317.	+00235.	+00340.	PSI
INST PRS	+00312.	+00235.	+00339.	PSI
INST PRS	+00305.	+00235.	+00339.	PSI
INST PRS	+00298.	+00235.	+00340.	PSI
INST PRS	+00289.	+00235.	+00340.	PSI
INST PRS	+00281.	+00236.	+00340.	PSI
INST PRS	+00272.	+00235.	+00340.	PSI
INST PRS	+00264.	+00235.	+00340.	PSI
INST PRS	+00257.	+00235.	+00340.	PSI
INST PRS	+00250.	+00235.	+00340.	PSI
INST PRS	+00245.	+00235.	+00340.	PSI
INST PRS	+00242.	+00236.	+00340.	PSI
INST PRS	+00240.	+00235.	+00340.	PSI
INST PRS	+00239.	+00235.	+00340.	PSI
INST PRS	+00241.	+00235.	+00340.	PSI
INST PRS	+00244.	+00235.	+00340.	PSI
INST PRS	+00249.	+00235.	+00340.	PSI
INST PRS	+00255.	+00236.	+00340.	PSI
INST PRS	+00263.	+00235.	+00340.	PSI
INST PRS	+00272.	+00235.	+00340.	PSI
INST PRS	+00282.	+00235.	+00340.	PSI
INST PRS	+00291.	+00236.	+00340.	PSI
INST PRS	+00300.	+00235.	+00339.	PSI
INST PRS	+00308.	+00235.	+00340.	PSI
INST PRS	+00315.	+00235.	+00340.	PSI
PK PRESS	+00320.	+00235.	+00339.	PSI
MOT SPD	+012.89	+000.15	+000.14	HZ
MOT PWR	+0016.7	+0000.0	+0000.0	W
HTR PWR	+00107.	+00000.	+00004.	W
LOAD PWR	+000.02	+000.03	+000.00	W
HT CYL T	+00612.	+00028.	+00024.	DGC
CRKS TEMP	+0040.2	+0028.2	+0028.5	DGC
CLD TMP	+0104.3	+0300.1	+0300.2	DGC

Figure 28. Sample data printout from teletype (Note: units 2 and 3 disconnected)

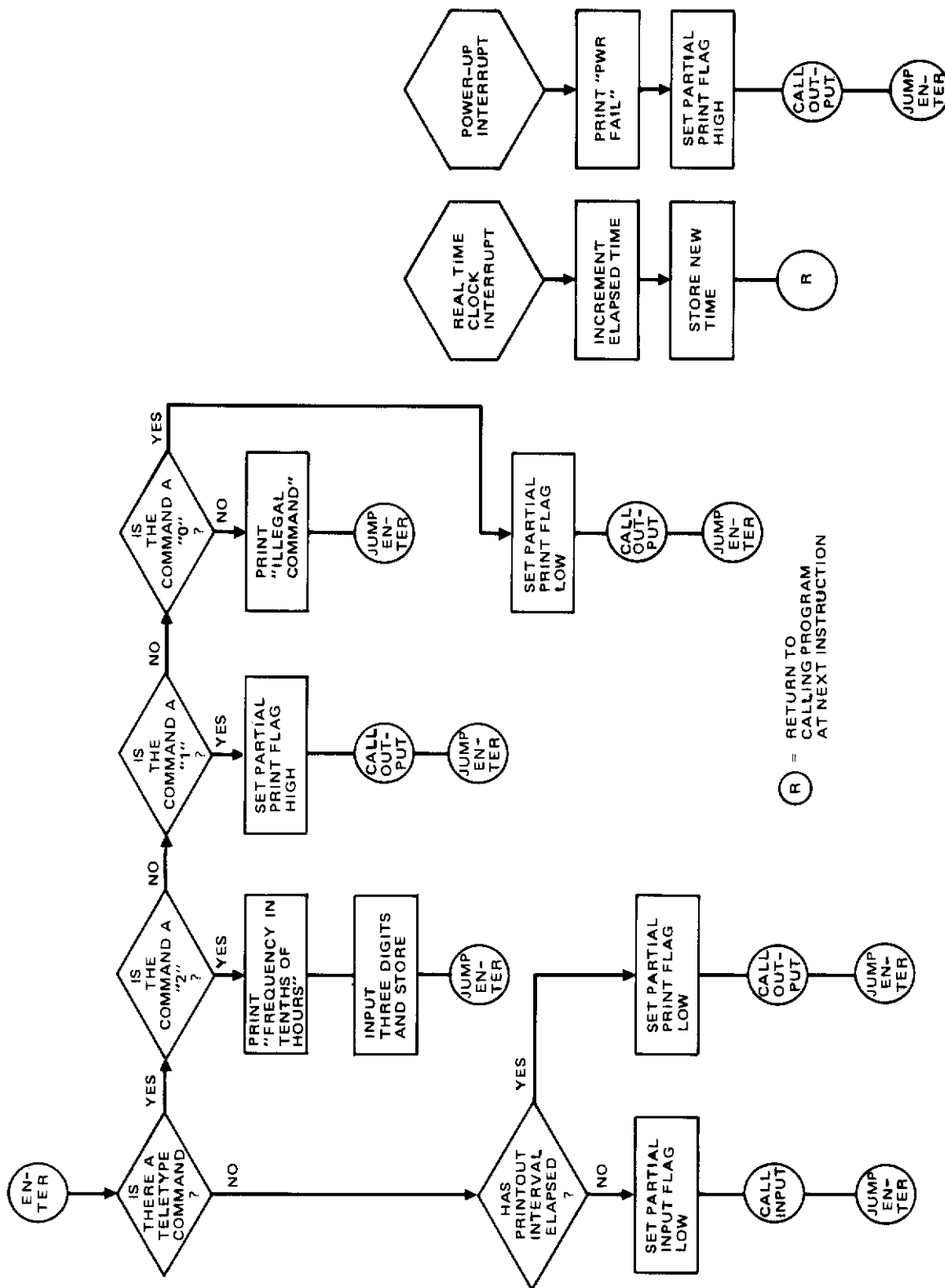

Figure 29. Flow diagram of main program and intercepts used in 77°K VM wear rate program

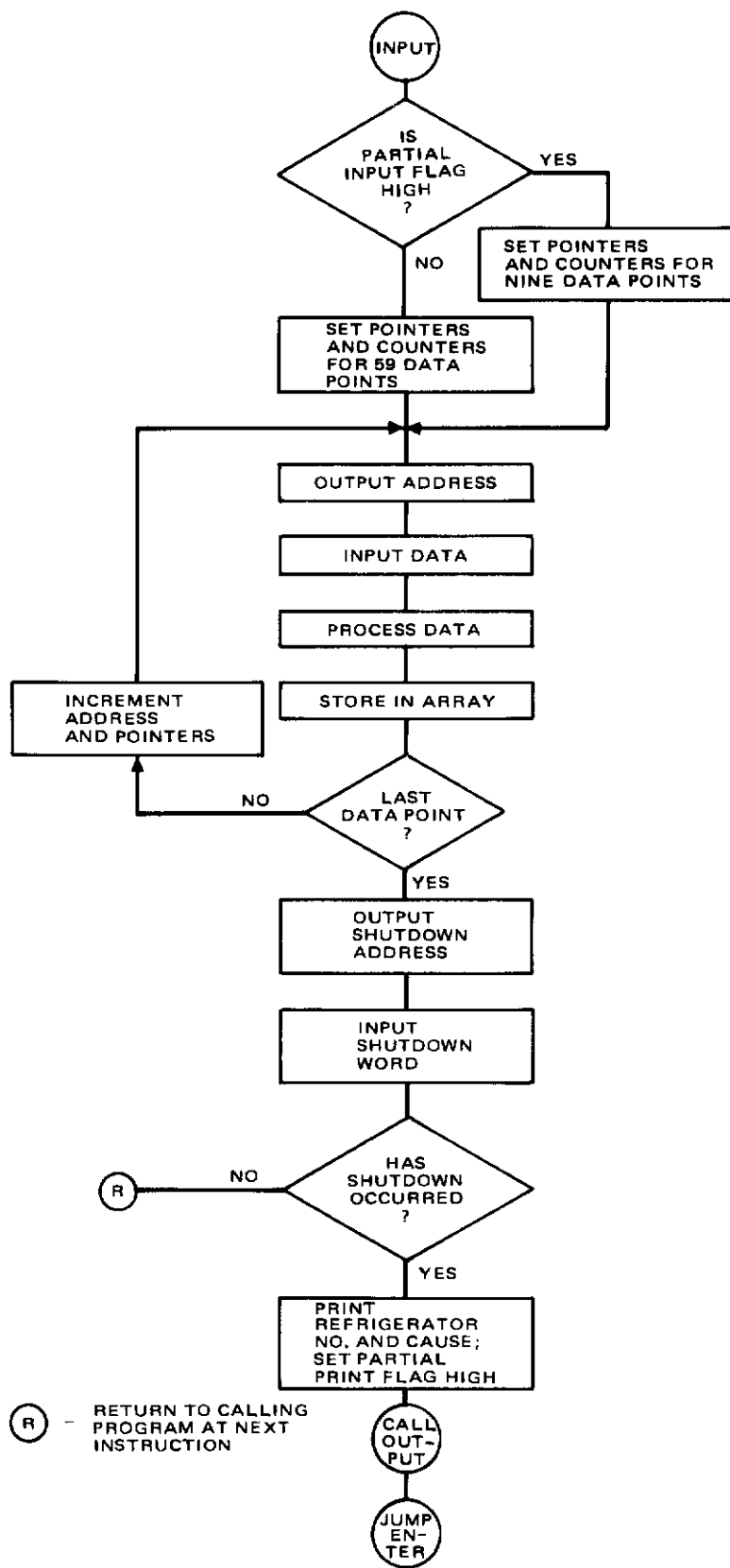

Figure 30. Flow diagram of data input subroutine used in 77°K VM wear rate program

(R) - RETURN TO CALLING PROGRAM AT NEXT INSTRUCTION



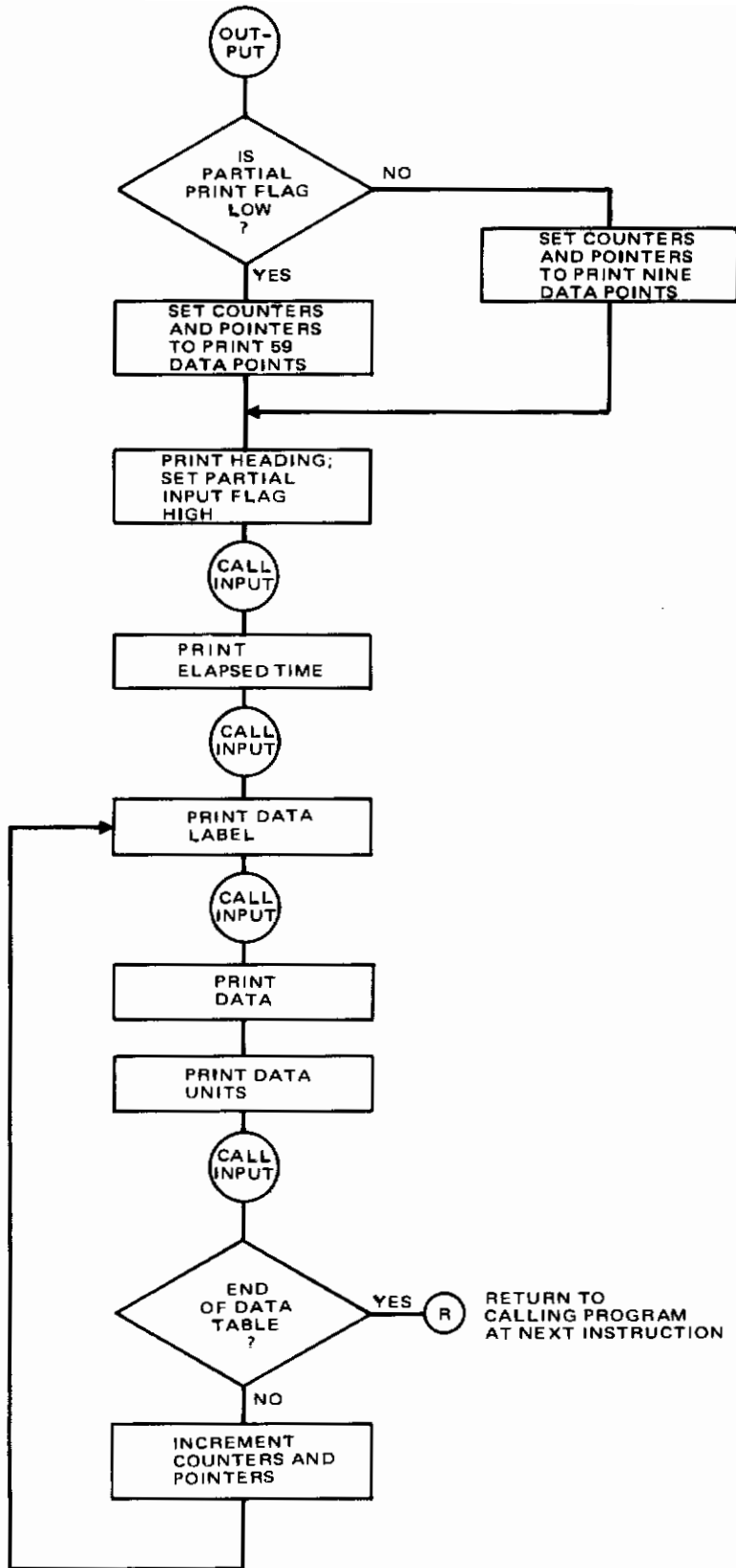

Figure 31. Flow diagram of data output subroutine used in 77°K VM wear rate program

# Contrails

In its acquisition mode, the computer:

- Sequentially outputs addresses to the multiplexer in the test control panel.
- Inputs the resulting data word and processes it. In the case of thermocouple voltages, the computer uses a curve fitting technique to convert the voltage to degrees centigrade (or Kelvin). The resulting temperature is stored in a data array in binary form. The most significant four bits of each computer word store the decimal point position. The remaining 12 bits store the magnitude of the data points.

After updating a complete set of data points, the computer inputs a status word from each refrigerator. If this word indicates a fault has occurred, the computer branches to another routine and prints the fault that has occurred, the number of the refrigerator involved, the time, and a complete set of data points. Then the computer returns to the acquisition mode.

After updating the status word for each refrigerator, the computer checks to see if an operator command has been input via the teletype. The following commands are recognized.

- "0" commands a complete printout of the data now in the data array.
- "1" commands a printout of all data points exclusive of instantaneous pressures (50 readings for each refrigerator taken over one revolution of the displacer motor).
- "2" indicates that the operator wishes to change the interval between automatic data printouts. Upon receipt of this command, the computer prints "What interval in tenths of hours?" It then stops and waits for the operator to enter a three digit decimal number. This allows intervals from 12 minutes to slightly over four days.
- When any other character is received, the computer prints "illegal input."

# Contrails

When the computer is printing data, it checks at the end of each line for a refrigerator fault. If a fault occurs, it discontinues printing data and reacts to the fault as described above.

If power to the computer fails, the data in the memory is not lost. When power is restored, the computer comes up running and branches to a routine which (1) prints "pwr fail", (2) prints the time of failure, and (3) prints all the data that was in the array when the failure occurred. Then it returns to the acquisition mode.

The computer has a core memory of 8,192 words (16-bit binary). Memory locations are numbered in hexadecimal :0000 through :1FFF. The program described above resides in locations :18A0 through :1FFF. The Omega II assembly program resides in location :0000 through :16E0. Some interrupt locations are used by both the Omega assembler and the main program; hence, only one at a time is fully operational.

A description of the various parts of the main program follows:

:18A0 Power fail routine  
:1900 Executive. Transfers control between various subroutines.  
:19A0 ETI. Keeps track of real time elapsed hours.  
:1A00 Acquisition program. Sequences addresses, processes routine pointers, etc.  
:1B00 Load power routine. Converts input word to power in watts.  
:1B10 Heater power routine. Converts input word to power in watts.  
:1B20 Motor speed routine. Converts input word to speed in Hertz.  
1B40 Pressure routine. Converts input word to psi.  
:1B50 Hot end temperature. Converts input word to °C.  
:1B60 Motor power routine. Converts input word to watts.  
:1B80 IOD. Interface program. Outputs address and returns with data word.  
:1D00 Cold end temperature. Converts data word to °K.  
:1DA0 Output routine. Outputs data. Prints heading, data label, and units. Converts from binary to decimal. Strips decimal point from data word and prints it.

# Contrails

Figure 32 shows a sample assembly listing for the above program. Column one shows the decimal source line numbers. Column two is the hexadecimal memory location. Column three is the hexadecimal machine code (punched on object tape). The assembler label, operation, and operand are also shown.

The test system is fully automatic but can also operate in a semiauto-  
matic or manual mode. The test program will begin to run automatically  
when the system is turned on. A console disable switch is located in a small  
depression on the right edge of the computer front panel. When this switch  
is down, the front panel buttons are inoperative. This switch prevents  
tampering with the buttons on the front of the computer that could modify or  
destroy the test program during system test. The following procedure is  
followed to reload the test program when required.

1. Load the main program tape in the teletype tape reader. Set the switch on the teletype reader to RUN. Set the mode select switch on the teletype to LINE.
2. Be sure the console disable switch (right edge of computer panel) is up. Depress the STOP switch on the computer. The light above the STOP switch will come on.
3. Depress the SREG/DATA switch (lower right corner of computer panel). The indicator light above the switch will come on. Depress the "0" switch on the hexadecimal keyboard.
4. Depress the STOP switch on the computer. The light above the switch will go out.
5. Momentarily depress the RESET switch.
6. Depress the AUTO switch. After a few seconds, the tape reader will begin to run. The reader will stop at the end of the tape.
7. Load the INTERRUPT LOCATION tape into the teletype. Repeat steps 2 through 6.
8. To begin program execution, turn off power to the computer (switch on back of computer), then reapply it. The teletype will print "pwr fail" and begin executing the program.

# Contrails

```

PAGE 0001

0001 1B80          ABS      : 1B80
0002 1B80 FA02     JST      IOD
0003 1B81 0800     HLT
0004 1B82 F602     JMP      5-2
0005 1B83 0800     ENT      IOD
0006 1B84 1357     LLA      8
0007 1B85 9A3A     STA      ADD
0008 1B86 0350     ARP
0009 1B87 9A30     STA      BYTONI
0010 1B88 B232     LDA      OUTPUT
0011 1B89 98E8     STA      GPINT
0012 1B8A B227     LDA      OTDAT
0013 1B8B 9A31     STA      MODE
0014 1B8C B226     LDA      OPUT
0015 1B8D 9A2E     STA      BRANCH
0016 1B8E FA12     JST      READ
0017 1B8F C602     LAP      2
0018 1B90 9A27     STA      BYTONI
0019 1B91 B228     LDA      INPUT
0020 1B92 98E8     STA      GPINT
0021 1B93 B220     LDA      INDAT
0022 1B94 9A28     STA      MODE
0023 1B95 B21F     LDA      IPUT
0024 1B96 9A25     STA      BRANCH
0025 1B97 FA09     JST      READ
0026 1B98 E227     LDX      ADD
0027 1B99 0408     CXR
0028 1B9A 132B     LLX      4
0029 1B9B 13AB     LRX      4
0030 1B9C 0110     ZAR
0031 1B9D 1960     MPY      A
      1B9E 1BB7
0032 1B9F 4404     OCA
0033 1EA0 F71D     RTN      IOD
0034 1BA1 0800     ENT      READ
0035 1BA2 B215     LDA      BYTONI
0036 1BA3 0310     NAR
0037 1BA4 98E9     STA      GPINT+1
0038 1BA5 B219     LDA      BUFADD
0039 1BA6 1350     LLA      1
0040 1BA7 0D01     SAI      1
0041 1BA8 98EA     STA      GPINT+2
0042 1BA9 B213     LDA      MODE
0043 1BAA 6CFB     OTA      GPDEVA+1
0044 1BAB B210     LDA      BRANCH
0045 1BAC 6CFB     OTA      GPDEVA+1
0046 1BAD 0A00     EIN
0047 1BAE F600     JMP      3
0048 1BAF 0800     ENT      EOB
0049 1BEC 2A00     EIN
0050 1BB1 F710     RTN      READ
0051 1BB2 0454     OTDAT   DATA : 0454
0052 1BB3 0254     OPUT    DATA : 0254

```

Figure 32. Sample assembly listing

PAGE 0002

```

0053 1BB4 046C  IN DAT  DATA  :046C
0054 1BB5 026C  I PUT  DATA  :026C
0055 1BB6 0000  ANS   DATA  0
0056 1BB7 5000  A     DATA  :5000
0057 1BB8 0000  BYTONI DATA  0
0058 1BB9 0000  PTR   DATA  0
0059 1BBA 54FA  I NPUT DATA  :54FA
0060 1BBB 64FA  O UTPUT DATA  :64FA
0061 1BBC 0000  BRANCH DATA  0
0062 1BBD 0000  M ODE  DATA  0
0063 1BBE 0000  C OUNT  DATA  0
0064 1BBF 1BC0  B U FADD DATA  ADD
0065 1BC0 0000  A D D   DATA  0
0066      00E8  G P I N T EQU   :E8
0067      00FA  G P D E V A EQU  :FA
0068 00E8      A E S   G P I N T
0069 00E8 1BB9      D A T A   P T R
0070 00E9 0000      D A T A   $- $
0071 00EA 0000      D A T A   $- $
0072 00EB 0000      D A T A   0
0073 00EC F9ED  J S T   *$+ 1
0074 00ED 1EAF  D A T A   E O B
0075      1B83  E N D   I O D
0000 ERRORS
    
```

PAGE 0003

```

ADD      1BC0      ANS      1BB6      A      1BB7      BRANCH  1BBC
BUFADD   1BBF      BYTONI  1BB8      COUNT  1BBE      EOB     1BAF
GPDEVA   00FA      GPINT   00E8      IN DAT  1BB4      INPUT   1BBA
IOD      1B83      IPUT   1BB5      M ODE  1BBD      OPUT    1BB3
CTDAT    1BB2      O U T P U T  1BBB      PTR     1BB9      READ    1BA1
    
```

Figure 32. (continued)



B. Wear Module Test Stand

The test stand for the wear module is similar to the 77°K test console previously described. It contains an LSI-02 computer for test control and data acquisition and processing. It contains a teletype to provide a hard copy readout of test parameters and faults.

Figure 33 is a schematic of the test stand, and Figure 34 shows the console itself, which interfaces with both the wear module and the Hi Cap VM cooler. Electronics in the wear module test control panel controls power to the module and its temperature. In addition, the panel contains data acquisition electronics for both the wear module and the Hi Cap VM cooler. Transducer signals from the wear module are buffered and scaled in this panel. Hi Cap transducer signals are buffered and scaled in the Hi Cap STE. The scaled signals from both the wear module and Hi Cap cooler are multiplexed into an A/D converter and sent to the LSI-02 computer. The computer

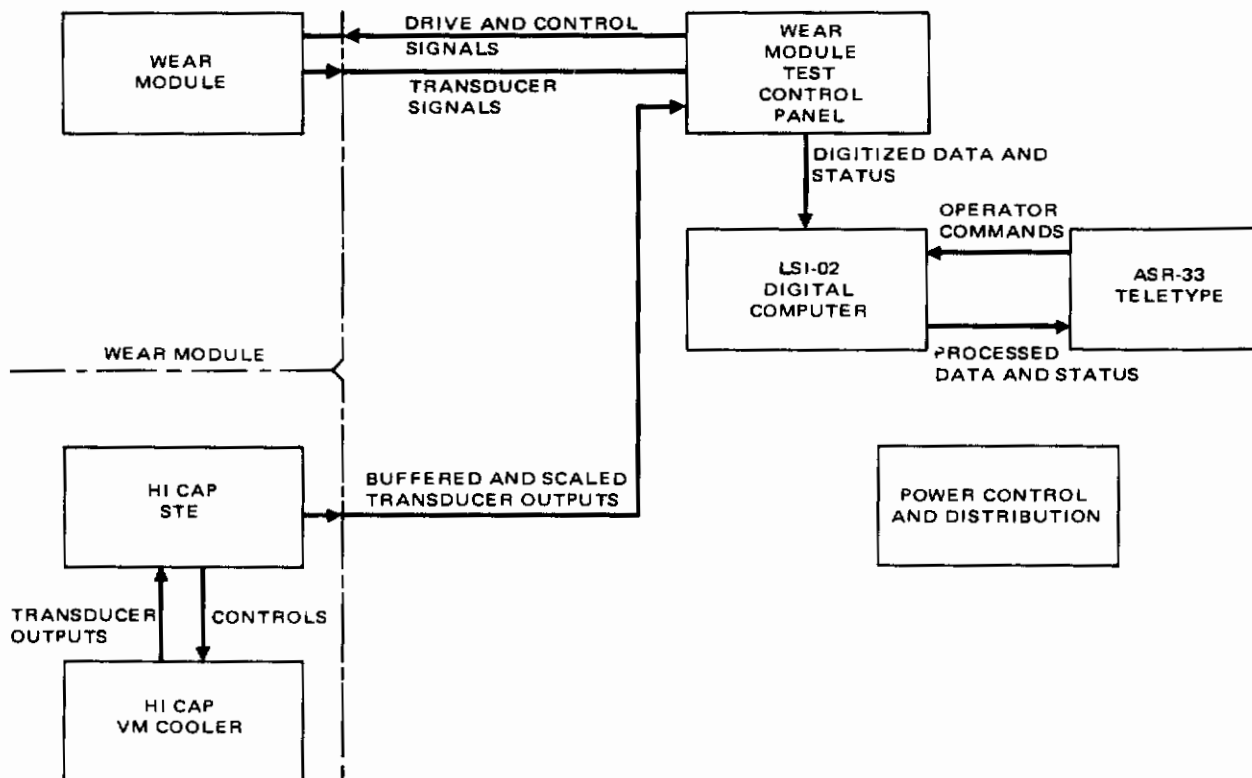

Figure 33. Schematic of wear module test console

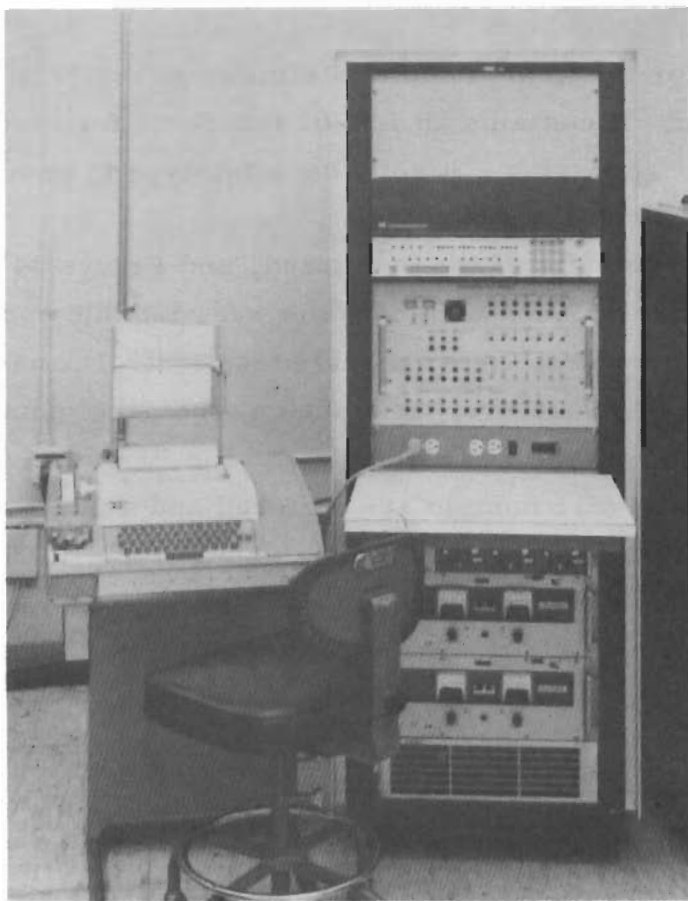

Figure 34. Wear module test console  
(76-50429)

processes and stores the data for output via the teletype. Outputs are provided automatically at regular intervals. Intervals of every six minutes to every four days can be chosen.

The computer recognizes eight commands, seven of which are shown in the sample printout (Figure 35). The eighth command, a period, causes the "Command Listing" shown to be printed. Typing any other character results in the message: "You have typed an illegal character, for a list of legal commands, type a period." The interval change commands (4 and 5) initiate a conversational sequence in which the old and new intervals are printed out to ensure that the proper interval is selected.

The wear module test stand computer program consists of approximately 6000 binary words of 16 bits each. The program is written in LSI machine

## COMMAND LISTING

TTY CMD	RESULT
1	COMPLETE HI-CAP PRINT
2	COMPLETE WEAR MODULE PRINT
3	PARTIAL WEAR MODULE PRINT (NO INST. PRESSURES)
4	ENABLES ENTRY OF NEW HI-CAP PRINT INTERVAL
5	ENABLES ENTRY OF NEW WEAR MOD PRINT INTERVAL
6	PRINTS ALL DATA (HI-CAP AND WEAR MODULE)
7	PARTIAL HI-CAP PRINT (NO INST. PRESSURES)

VM WEAR RATE PROGRAM  
ELAPSED TIME 0000.0 HRS

MOTOR SPEED	00.09 HZ	COOL TEMP I	000.0 DGC	COOL TEMP O	000.0 DGC
CRANK TEMP	000.0 DGC	HOT TEMP 1	0000. DGC	HOT TEMP 2	0000. DGC
HEATER PWR1	408.3 W	HEATER PWR2	408.3 W	PEAK PRESS	000.0 PSI

HI-CAP PROGRAM  
ELAPSED TIME 0103.0 HRS

MOTOR SPEED	0303. RPM	COOL TEMP I	056.5 DGF	COOL TEMP O	062.0 DGF
CRANK TEMP A	032.0 DGF	CRANK TEMP B	077.6 DGF	HOT TEMP 1	1265. DGF
HOT TEMP 2	1267. DGF	1ST TEMP A	054.5 DGK	1ST TEMP B	059.1 DGK
2ND TEMP A	040.3 DGK	2ND TEMP B	040.1 DGK	3RD TEMP A	025.4 DGK
3RD TEMP B	020.4 DGK	3RD TEMP C	21.52 DGK	1ST CLD HTR	12.00 W
2ND CLD HTR	09.98 W	3RD CLD HTR	0.300 W	MTR CURRENT	08.60 A
HT CYL CUR1	09.20 A	HT CYL CUR2	09.32 A	28V CURRENT	00.28 A
28 VOLT SUP	28.25 V	100 V SUP	085.6 V	MIN PRESS	0428. PSI
MAX PRESS	0569. PSI				

Figure 35. Sample printout from wear module teletype

language and is entered into the computer memory via a paper tape. The procedure for loading the tape is the same as that discussed previously for the 77°K stand.

The computer program operates similarly to the 77°K program. The computer sequences through all the input parameters (see sample printout shown in Figure 35), converts these signals to engineering units, and outputs the results via the teletype at certain intervals, or upon command. In addition, the computer monitors the various fault signals and produces a teletype message and a data readout when a fault occurs. If computer power fails, the computer prints a "pwr fail" message and gives a data readout when power is reapplied.

The flow charts (Figures 36 and 37) and the memory map (Figure 38) show the program in more detail.

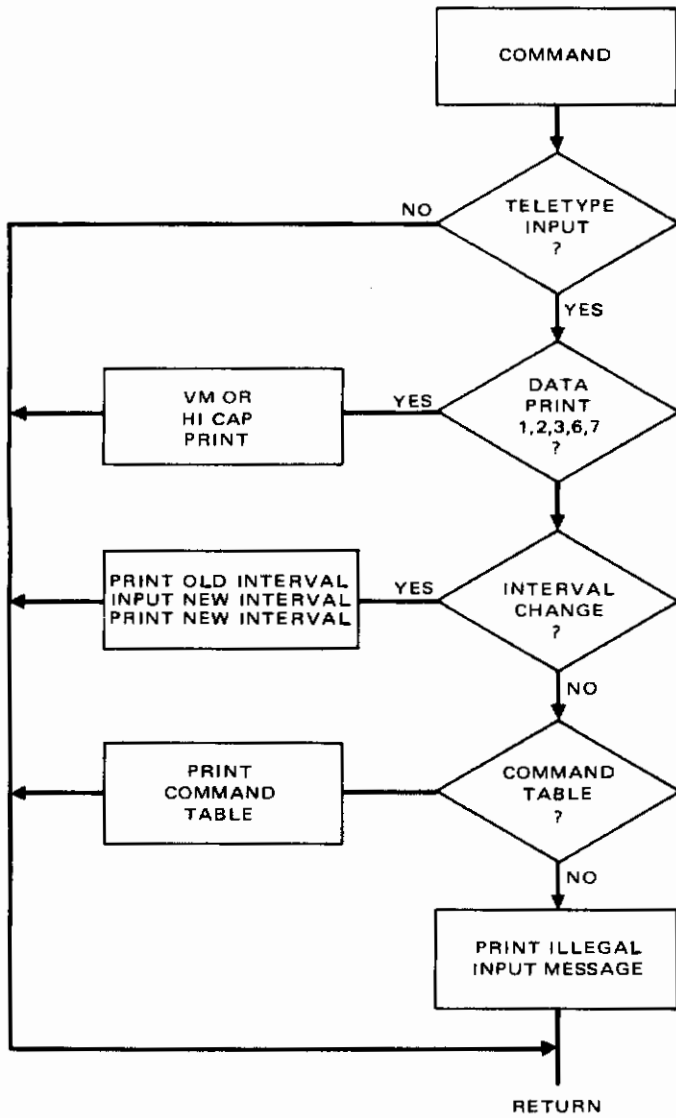

Figure 36. Teletype command routine

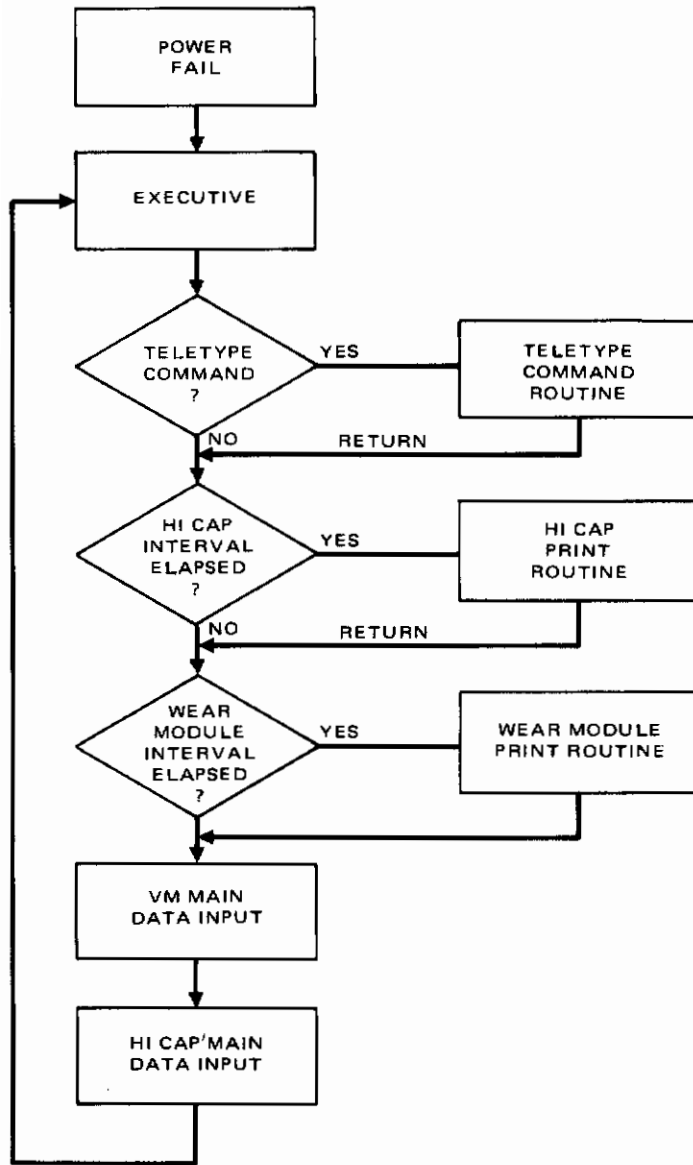

Figure 37. Flow chart of wear module program

<u>Memory Location</u>	<u>Program</u>
:1FF0	OTT (Character output)
:1FF5	FORMAT (String Output)
:1FD0	PRI (Print)
:1F64	ODEC (Binary to Decimal Print)
:1F99	ODEC1 (Truncated Binary to DEC)
:1E03	IOD (I/O Control)
:1E50	VM DATA (Data Array)
:1F03	VM HOT CYL TEMP (Process
:1D50	VM SHUTDOWN (Fault Detect)
:1CA0	VM TEXT (Label & Units Print)
:1C30	VM INSTR (Print)
:1BC3	VM CRANK - COOLANT (Process)
:1B90	VM PRESSURE (Process)
:1B9E	VM MOTOR SPEED (Process)
:1BAC	VM HOT CYL POWER (Process)
:1AF0	VM INPUT
:1A73	HI CAP INSTRU (Print)
:1940	HI CAP TEXT
:18B0	HI CAP FAIL (Faults)
:1830	HI CAP PROCESS
:1400	HI CAP DATA INPUT
:1252	INTERNAL CHANGE
:0000	PWR FAIL
:1080	EXECUTIVE
:1122	COMMAND TABLE
:1332	COMMAND
:13B0	REAL TIME CLOCK

Figure 38. Wear module memory map



# *Contrails*

The wear module test stand is completely fabricated, assembled, and tested. It has been successfully integrated with the Hi Cap VM cooler, but not yet with the wear module.

SECTION V  
TEST RESULTS

As of this reporting date, all three 77°K VM coolers and Hi Cap S/N 2 are in the midst of their incremental tests. Some short term test data has been gathered, but the information is not sufficient to empirically develop wear rate data on critical components and materials to ascertain which has the best long term operating potential. So far the test coolers have been in test for the following number of hours:

- Hi Cap VM S/N 2            1771 hours
- 77°K VM S/N 001        5125 hours
- 77°K VM S/N 002        3347 hours
- 77°K VM S/N 003        4087 hours

## 1. RESULTS WITH HI CAP VM S/N 2

Initial pretest checkout of the Hi Cap S/N 2 was started on 24 March 1976 and continued for approximately 65 operating hours. On 5 April 1976 the unit was purged, a gas sample taken (See Table 8), and the unit pressurized to 600 psig. This less than normal helium fill pressure of 710 psig was used because a leak had occurred between the coolant jacket and the internal helium volume on Hi Cap S/N 1. Until the cause of failure in this housing is determined, it was decided to operate at lower pressures to reduce stresses.

After two days of testing, a power failure at the plant facility caused an automatic shutdown, but the unit was restarted without any problems. The same shutdown occurred on 29 April, and the unit was again restarted, this time with the cold cylinder rotated 180 degrees, to the vertical "up" position. The unit had been tested for approximately 625 hours.

After 908 hours of operation, Hi Cap S/N 2 stopped operating. It was decided that during disassembly and investigation for the cause of the failure, the unit would be inspected for component wear in the same manner planned at the end of each 2500 hour test increment. Table 9 gives the results of that inspection. The failure investigation disclosed that the

TABLE 8. ANALYSIS OF HELIUM CAS SAMPLE

Gas	Composition, ppm	
	5 April 1976	22 July 1976
Hydrogen	<3*	<3*
Methane	<1*	<1*
Water	<3*	<3*
Nitrogen	1	10
Oxygen	<1*	<1*
Argon	<1*	<1*
Hydrocarbons as butane	<1*	<1*
Carbon dioxide	2	<1*
Helium	Balance	Balance

\*Limit of detection as analyzed by mass spectrometry

TABLE 9. HI CAP S/N 2 POST-TEST ANALYSIS (908 HR)

Hot Rider	Mat'l	Radial Wear, inches	Weight Loss, mg	Experimental Factor K, (from weight loss)
Cylinder 1	Boeing 6-84-1	0.0006 max 0.010 allowable	24.6	$2.5 \times 10^{-9} \frac{\text{in}^3\text{-min}}{\text{lb-ft-hr}}$
Cylinder 2	Boeing 6-84-1	0.0007 max 0.010 allowable	43.1	$4.38 \times 10^{-9} \frac{\text{in}^3\text{-min}}{\text{lb-ft-hr}}$

Ambient Riders      No loss of material from original rider. Material build-up from sealwear

Bearings      Two crankcase bearings replaced. They had failed under excessive thrust loads caused by deviated part. Three other bearings - no visible signs of excessive wear

Seals	Mat'l	Weight Loss, mg	Comments
Hot displacer	Rulon A	296.4	Lip thickness reduced 0.005/0.009 inch; replaced with 15% glass loaded teflon
First stage (Ambient)	15% GL	111.2	Material: 15% glass loaded teflon
Second stage	15% GL	0.4	
Third stage	Rulon A	0.9	

forward floating crank bearing had been abnormally loaded with a thrust load that caused the inner race of the bearing to crack and the balls to spall. Plasma spray material had built up on the bearing housing and decreased the bore of the bearing housing. This caused an interference fit with the bearing, and subsequently created an abnormal thrust load. The thrust load unloaded the preload on the outer bearing and increased the contact load on the inner bearing. The high contact loads on the rotating balls eventually spalled the balls, made the bearing fail, and caused the drive mechanism of the unit to freeze up.

The bearing surface of the housing was machined, both crankshaft bearings replaced, and the rulon A hot displacer seals were replaced with a 15% galss loaded teflon seals. During pretest checkout, an unusual noise was detected inside the machine. After a considerable amount of time was spent testing and checking, a slight interference on the cold end at top dead center was observed and corrected. On 22 July 1976, the unit was purged, a gas sample taken (See Table 8), the unit pressurized, and testing resumed.

After three weeks of operation with the cold cylinder in the down position, the unit was rotated 180° according to the test plan so that the cold cylinder pointed up. The unit operated in this position for four days at which time the unit was manually shut down to evaluate the cause of the increase in the temperature of hot cylinder 2 over the weekend from 1229°F to 1334°F. Switching the redundant heater circuit to REDUNDANT CONTROL returned the hot cylinder back to normal operating temperature. When the access panel to the IFU was removed, a considerable amount of water was found around the 100-volt power transistors. In addition there were evidences of arcing and corrosion around the transistor terminals. The water was removed, the panel installed, and the unit was put back into test with the cold cylinder returned to the down position. It was concluded that when the cold cylinder was pointed up, water condensate, caused by the low temperature coolant, apparently leaks through the IFU access panel gasket. The power transistor will be replaced and the gasket leak will be corrected at the end of the 2500-hour incremental test period. The following changes in the test conditions were noted:

- Hot cylinder 2 will be operated in the "Redundant Control" mode.

- The unit will finish out this incremental test period with the cold cylinder in the down position.

## 2. RESULTS WITH 77°K VM COOLERS

The 77°K VM cooler S/N 001 began its initial three-month incremental test on 21 November 1975. Subsequently, coolers S/N 002 and S/N 003 were also put into test using hot rider rings of different materials. Test results through 27 August 1976 are reported in the following paragraphs.

Cooler S/N 001 has completed two incremental test periods lasting over three months each (2160 hours) and is now into its third test period. Including pretest and post-test hours, the unit has accumulated 5125 hours. During this period, the only component replaced was the cold end seal. The cold displacer assembly was originally assembled with a rulon-J Bal seal because it was the only seal available at that time. The refrigerator cold end performance gradually deteriorated during the second test phase, and the high cold end temperature at post-test was found at disassembly to be due to the substantial (56 percent) reduction in drag force of the rulon-J seal. Rulon-J, which was a substitute material, was replaced with a 15-percent glass loaded teflon seal for the third incremental test phase. During the 4429 hours of operation, the rulon-J seal lost approximately 6.4 mg of weight. When more test data is collected, the experimental K factor for wear prediction for each material can be determined.

Since the primary purpose of using the three 77°K VM coolers in the wear rate tests is to evaluate hot end rider materials, various pretest and post-test measurements have been made and the results recorded. Table 10 summarizes the hot end rider materials tested. S/N 001 will continue to test the set of 6-84-1 rings installed at the beginning of the test program.

Figure 39 presents an early estimate of hot rider ring life in a Hi Cap refrigerator based on ring weight loss measurements in the S/N 001 small VM cooler. Additional data from the small coolers and the Hi Cap cooler is needed to validate the curve.

The motor bearings initially used were those originally received in the GFE machine because new ones did not arrive in time. These were replaced

TABLE 10. 77°K VM HOT RIDER RING TEST RESULTS

Cooler S/N	Test Run No.	Rider Mat'l	Test Run, hr	Cum- ulative Rider Test, hr	Radial Wear, inches		Weight Loss, mg	K, $\left(\frac{\text{in}^3\text{-min}}{\text{lb-ft-hr}}\right)$
					Max	Nom		
001	1	6-84-1 <sup>(a)</sup>	2254	2254 <sup>(b)</sup>	0.00050	0.00018	14.7	$2.22 \times 10^{-8}$
002	2	PM- <sup>(c)</sup> 107	2254	2254 <sup>(d)</sup>	0.00242	0.00172	21.6	$2.61 \times 10^{-8}$
003	3	108	2220	2220	(e)	(e)	(e)	-
001	4	6-84-1	2175	4429	(f)	(f)	4.0	$0.63 \times 10^{-8}$

(a) Density measured at 5.8 g/cm<sup>3</sup>.  
 (b) Average cooler speed of 675 rpm.  
 (c) Density measured at 7.6 g/cm<sup>3</sup>.  
 (d) Average cooler speed of 643 rpm.  
 (e) Unable to measure because of material failure.  
 (f) Measurement postponed for additional 2100+ hours of testing.



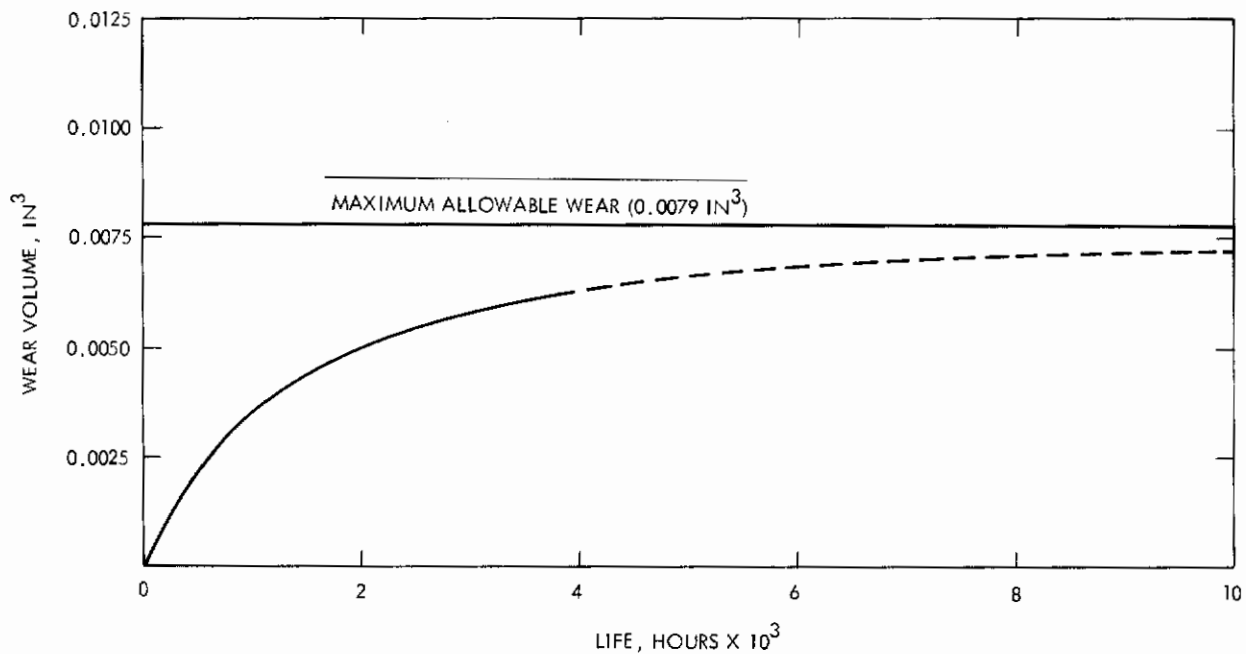

Figure 39. Results of first two-incremental test of 77°K refrigerator S/N 001 extrapolated for Hi Cap

in S/N 001 before the start of the third incremental test. A new duplex pair of bearings was also installed in the connecting rod; problems with the test instrument did not allow initial torque measurements to be taken. All bearings will be evaluated in the bearings laboratory at the end of test program, provided that there are no failures before that time.

Cooler S/N 002, into its second test phase, has accumulated 3347 hours. The cold end seal, the ambient seal, and the motor bearings were replaced at the conclusion of the first incremental test.

The cold end seal was replaced with 15-percent glass loaded material for reasons previously explained. The rulon-J seal that was removed at the end of the first incremental test of 2254 hours showed a weight loss of 1.375 mg. The seal appeared usable but was replaced with the superior 15-percent glass loaded teflon material.

The ambient seal on the hot displacer showed very little drag force at disassembly although visual inspection showed no evidence of excessive

# Contrails

wear. Post-test measurement disclosed a weight loss of 13.7 mg during the 2200+ hours of testing.

Although all of the ball bearings appeared in good condition after the first incremental test, both motor bearings (single and a duplex pair) were replaced because they were used bearings before the test began. The average running torque of the connecting rod bearings had increased, based on the rundown time from 600 rpm, but these bearings were reinstalled and are now operating.

Cooler S/N 002 is testing the wear rate of a Pure Carbon Molalloy PM-107 hot rider ring. This material is Pure Carbon Company's equivalent of Boeing compact 6-84-1, which is being tested in S/N 001. As shown in Table 10, the total weight loss experienced by the PM-107 material hot rider ring was almost 1.5 times that of Boeing compact 6-84-1 over the initial incremental test period. The PM-107 set of rider rings has been reinstalled in S/N 002 and is undergoing further testing.

Cooler S/N 003 has accumulated 4087 hours of testing while almost completing its second three-month incremental test. At the conclusion of the first incremental test period, the cold end seal, the ambient seal, and the hot rider ring were replaced.

After operating for 385 hours, the rulon-J cold end seal was replaced with a 15-percent glass loaded teflon seal in hopes of lowering the 100°K plus cold end temperature. However, no improvement was observed, and the test was continued to conclusion. There was a considerable amount of debris at the cold end seal at disassembly; this may have contributed to the poor performance. A new 15-percent glass loaded teflon seal was installed before the start of the second three-month incremental test.

The ambient seal on the hot displacer produced no drag force at disassembly following the first three months of testing. Inspection disclosed sufficient wear of the seal (there was some misalignment) to cause the hot displacer to rub and score the housing. Post-test measurement showed a weight loss of 19.75 mg during the 2220+ hours of testing.

# *Contrails*

The soft Boeing compact 108 hot rider ring developed cracks during the initial test period and fell apart during disassembly. Because of the many broken pieces, the maximum wear segment and the total weight loss could not be determined. The available Boeing compact 6-84-1 ring, similar to that in S/N 001, was installed in S/N 003 and is being tested.

## SECTION VI RIDERLESS VUILLEUMIER DESIGN

Hughes has been developing VM cycle refrigerators for nearly ten years. This development was initiated because these refrigerators have the potential of extremely long operating life, but lifetimes in excess of 4000 hours had not as yet been demonstrated. When the wear rate program was initiated, the life limiting component was the rider that separates the hot displacer and its cylinder; this rider operates at approximately 1200<sup>o</sup>F. New materials are currently being evaluated to extend the operating life.

Riders that operate at ambient and cryogenic temperatures are also utilized in VM refrigerators and these do not appear to limit the operating life. Consequently, a design study was conducted to determine the feasibility of eliminating the hot rider completely and the penalties incurred. In the design, the hot displacer floated on supports operating at ambient temperature.

In conjunction with this study, the advantages and consequences of converting the Hi Cap type a-c motor into a brushless d-c motor were also investigated. The next two sections discuss the results of these efforts.

### 1. COOLER ANALYSIS AND DESIGN

The thermal design utilized for the refrigerator in this study was the cryo cooler for satellite sensors (CCSS). This refrigerator was described in AFFDL-TR-75-154; an outline drawing is shown in Figure 40. The internal configuration of the refrigerator is illustrated in Figure 41; this design utilizes a conventional support for the hot displacer by both an ambient and a high temperature rider. This hot end configuration is identical to one of the hot cylinders in the Hi Cap refrigerator.

### 2. DESIGN CRITERIA

The design goal for the life of the refrigerator is 30,000 hours. The refrigerator is designed to operate in space where the load on the riders can be reduced considerably compared to terrestrial usage. In this study, the design was evaluated for the most adverse conditions. Wearing surfaces were analyzed for terrestrial operation where riders must support the weight of the displacer in a single orientation for the full 30,000 hours.

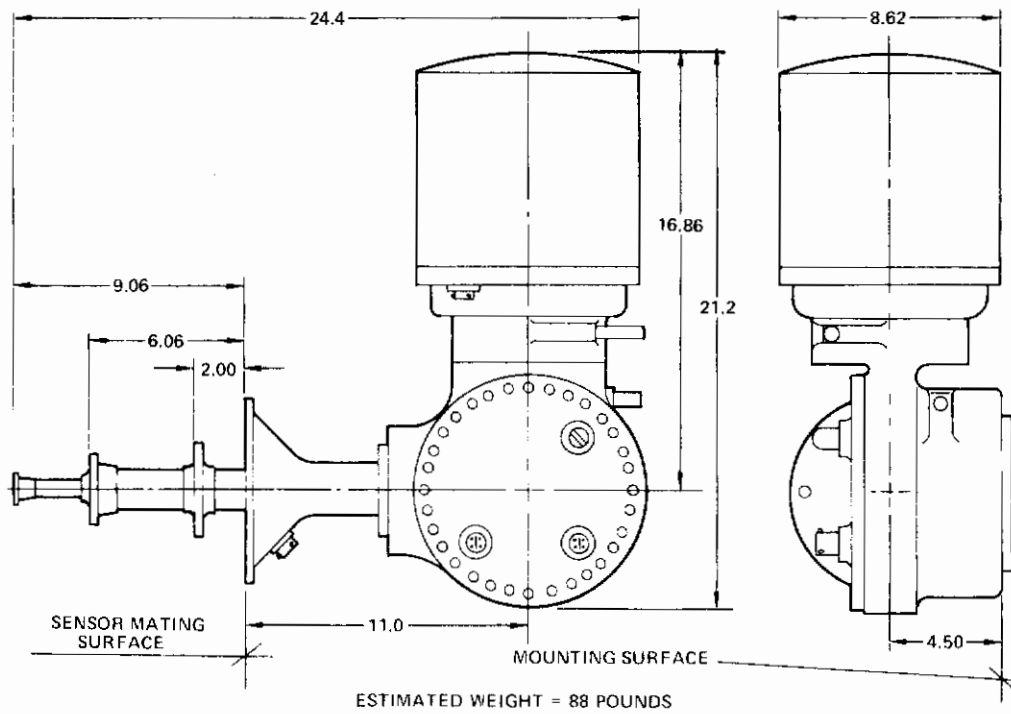

Figure 40. Envelope of CCSS refrigerator

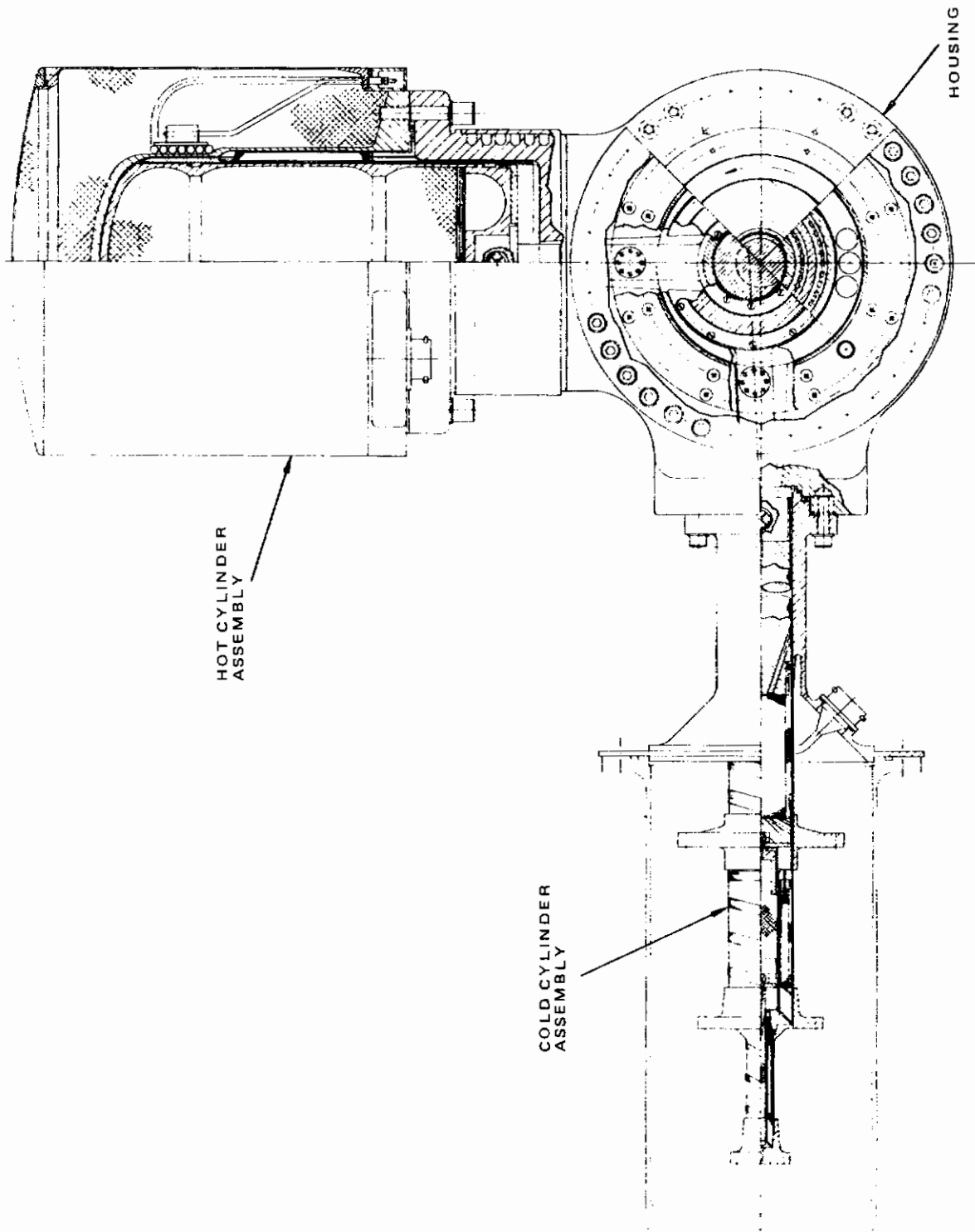

Figure 41. Internal configuration of CCSS refrigerator



The CCSS design utilized a single hot displacer rather than two hot displacers as does the Hi Cap refrigerator, but the study was not limited to a one-displacer system. If a riderless method of supporting two hot displacers had proven more feasible, it would have been selected. All methods studied are equally applicable to either single or dual hot cylinder configurations.

The active elements of this design, except for the hot rider, are similar to those in the Hi Cap refrigerator. The same ambient and cryogenic seals and riders are employed, and transfer lubricated, ball bearings are utilized in the crankcase.

Replacing the flexural pivots with dry lubricated spherical joints was considered. Calculations based upon the manufacturer's experience indicate that the fabric teflon liner in this bearing would wear less than 0.003 inch in 30,000 hours. A sample bearing was obtained and it immediately became apparent that the bearing required considerable torque to provide the oscillating motion. Consequently, it is not proposed that spherical joints replace the flexure pivots. This design does call for a larger flexural pivot than was utilized in Hi Cap. The maximum turning moment introduced by the flexure pivot is 1 in-lb.

Study criteria included minimizing the additional dead volume, size, weight, and input power required by a riderless design.

### 3. DISPLACER DESIGN

Obviously if the weight of the present hot displacer could be reduced; the rider loads and consequently the radial wear would also be reduced. A review of the thermal design indicates that it is not possible to significantly shorten the displacer. The hot displacer assembly is composed of four components:

<u>Component</u>	<u>Weight, lb</u>
Metallic shell	3.7
Base	2.7
Bearing housing	0.5
Min-K insulation	<u>1.6</u>
Total	8.5

The center of gravity is located approximately four inches forward of the crankcase end of the displacer.

The weight of the displacer could be reduced in two ways. The simplest method would be to eliminate the Min-K insulation and replace it with vacuum insulation; this would reduce the weight about 20 percent. However, this approach would introduce a radiation heat loss on the order of 200 watts unless very low emissivity internal surfaces are maintained or intermediate-temperature radiation shields are incorporated in the displacer. Shielding will undoubtedly counterbalance any weight savings. Also it is highly unlikely that low emissivity surfaces can be maintained during fabrication and assembly. Hence, it does not appear that removing the fibrous insulation is a viable method of reducing weight.

Using a pressurized hot displacer would allow the wall thickness of the metallic shell to be reduced to thereby reduce the weight of the displacer by approximately 20 percent. A method of filling the displacer with helium and then sealing it in must be incorporated in the design. Preliminary estimates indicate that the weight of a fill mechanism would counterbalance the weight saved by reducing the thickness of the shell.

In view of the above, it was concluded that the weight of the hot displacer cannot be significantly reduced. Therefore, the present 8.5-lb hot displacer was utilized in the design of a refrigerator using hot riders.

Following the review, other methods somewhat unorthodox, of supporting the displacer were investigated.

#### 4. METHODS OF SUPPORTING DISPLACER

When two permanent magnets with like poles approach each other they generate a separating force. The magnetic strength of a material decreases as its temperature is increased; consequently, stronger forces can be achieved by operating a magnet at normal temperatures. Figure 42 is a schematic of a magnetic suspension for the hot displacer where the magnets operate at ambient temperature. This method was rejected because of the large amount of magnetic material needed to achieve the more than 5 lb of force essential for the separation. Another concern leading to the rejection of

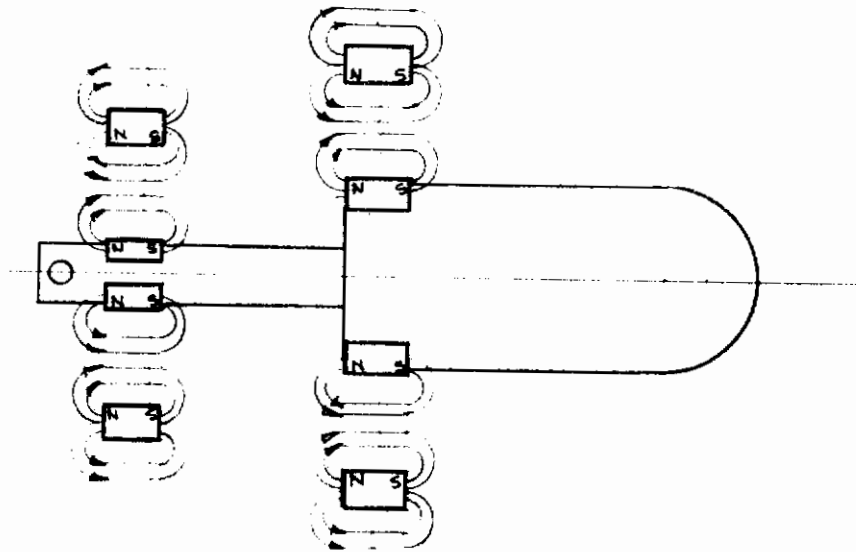

Figure 42. Schematic representation of magnetically supported displacer

this approach was that, the demagnetization effect that may occur with long term operation as a result of the relative motion of the two magnetic fields was unknown.

The hot displacer could be supported on a gas bearing that permits axial movement without the necessity of rotation. Figure 43 shows a schematic arrangement for pneumatically supporting the hot displacer. The bearing consists of two cylindrical parts with an extremely close fit (on the order of 0.0001 inch); relative motion between the parts causes a pressurization effect in the annular clearance. There are two significant difficulties with this approach. First, the bearing diameter occupies a significant portion of the ambient displaced volume behind the hot displacer. Because of the desired pressurization effect to float the displacer, this volume is not in free communication with the other active volumes, and this radically changes the thermodynamic cycle. In addition, the very close fit makes the pneumatic support highly susceptible to contamination debris. Therefore, pneumatic suspension was rejected.

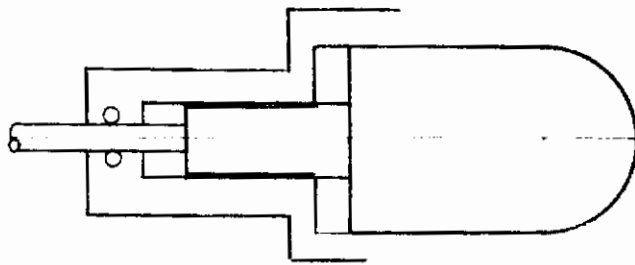

Figure 43. Schematic representation of pneumatically supported displacer

The hot displacer could be supported by ball bearings that roll within a confining groove (see Figure 44). In this method, a bearing race rolls on a mating surface without lubrication. Sufficient data on the life of the surfaces under these conditions is not available to provide confidence in extended operation. Further, significant dead volume is introduced in the support area; consequently, this method was rejected.

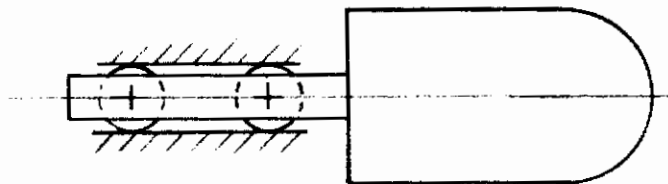

Figure 44. Schematic representation of roller supported displacer

Figure 45 schematically shows a method of supporting the hot displacer in a manner similar to a traverse drapery rod. No practical implementation of this concept could be devised.

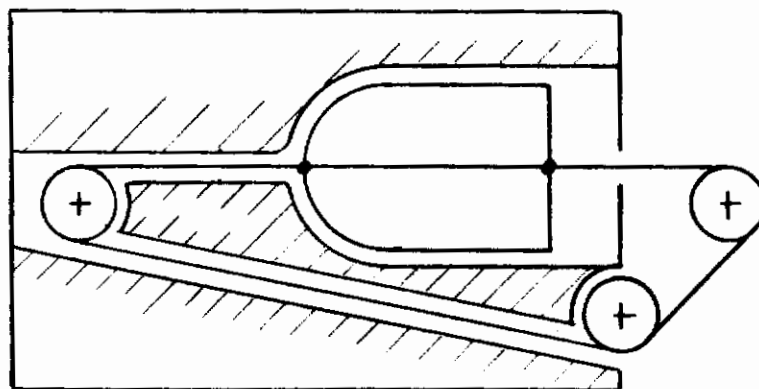

Figure 45. Schematic representative of wire supported displacer

Figure 46 shows a design in which the hot displacer is supported from its ambient end by a cantilever crosshead. This support differs from those utilized for large, unlubricated compressors used in processing industries in that the diameter of the crosshead is smaller than that of the displacer. This is a practical approach in a VM refrigerator because the mechanical loads are small and are more constant over the cycle.

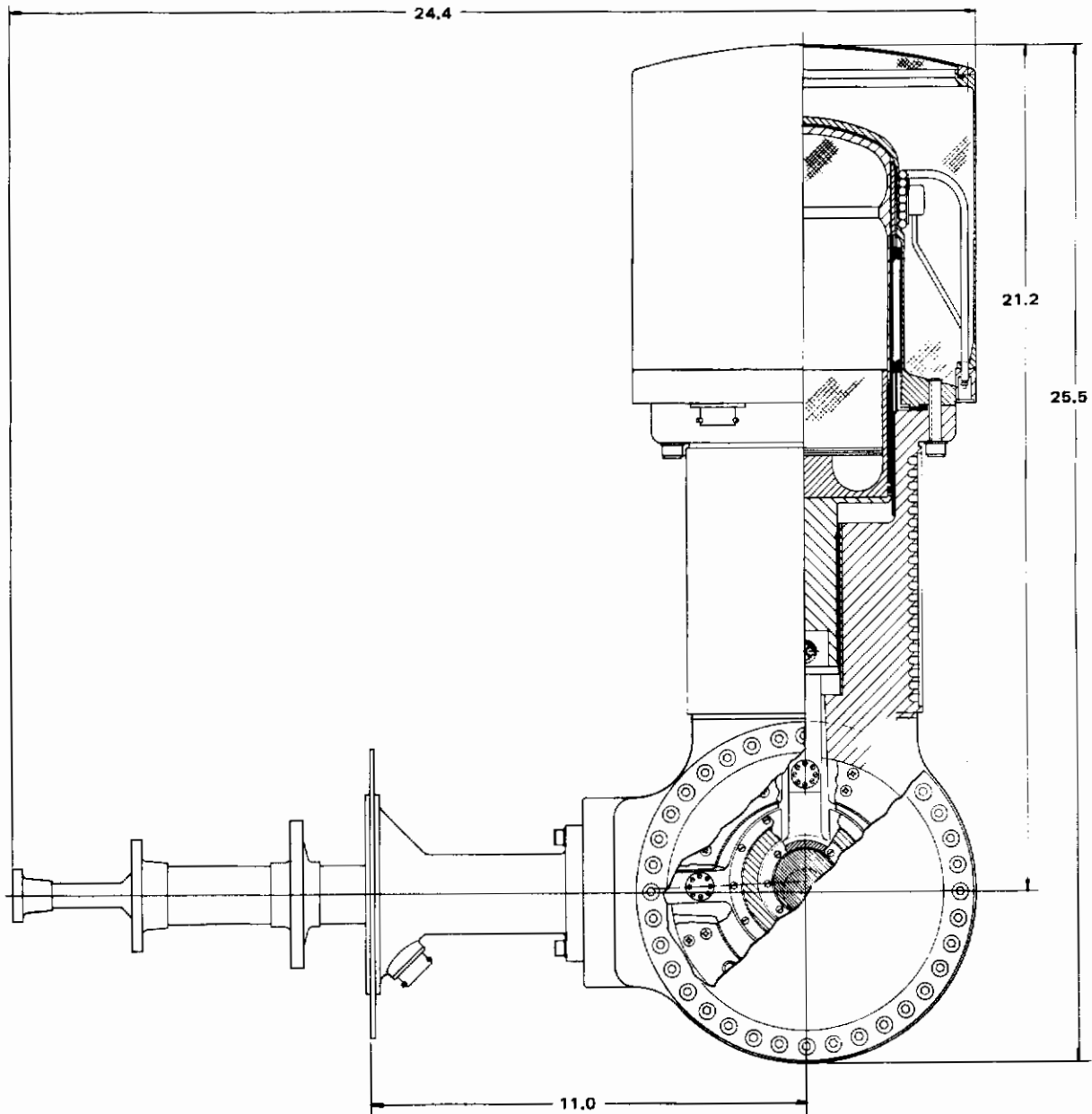

Figure 46. Crosshead support



The smaller guide piston has a length to diameter ratio of 1.8, which is greater than the common design value of 1.5 that is utilized in hydraulic and pneumatic equipment. Actually, most of the weight of the hot displacer is supported by the large ambient rider, which has a length to diameter ratio of 0.6. The smaller diameter crosshead supports only a minor portion of the displacer loads but it provides guidance and counteracts the tilting moments that the crank mechanism impose on the displacer. The crosshead could be the same diameter as the displacer but this has several drawbacks.

- A longer crosshead is needed to maintain the desired L/D ratio
- Dead volume is increased
- A greater amount of wear debris is generated.

The computed support loads under normal terrestrial operation are 11 lb on the displacer rider and 2.5 lb on the crosshead rider. The computed wear for 30,000 hours of operation on 15-percent glass loaded riders are 0.005 and 0.003 inch for the displacer and crosshead riders, respectively. The hot end of the displacer will sag 0.011 inch under these conditions; the nominal clearance is 0.016 inch. Both riders operate at crankcase temperature.

The design increases the dimension from the top of the hot cylinder to the back of the crankcase from 21.2 to 25.5 inches. The dead volume is increased only 0.4 percent above the baseline CCSS configuration. No additional heater power is required. The hot displacer is identical to that in the CCSS except that the crosshead has been added. The weight of the refrigerator will be increased by approximately 20 lb. It was concluded that this approach was viable.

Figure 47 illustrates a concept that reduces the additional weight and the increased length resulting from the conventional crosshead support just described. In this design, two riders support the hot displacer; one is folded into the middle of the hot displacer, and the other is on the exterior of the displacer. The length to diameter ratio of the crosshead is 1.5,



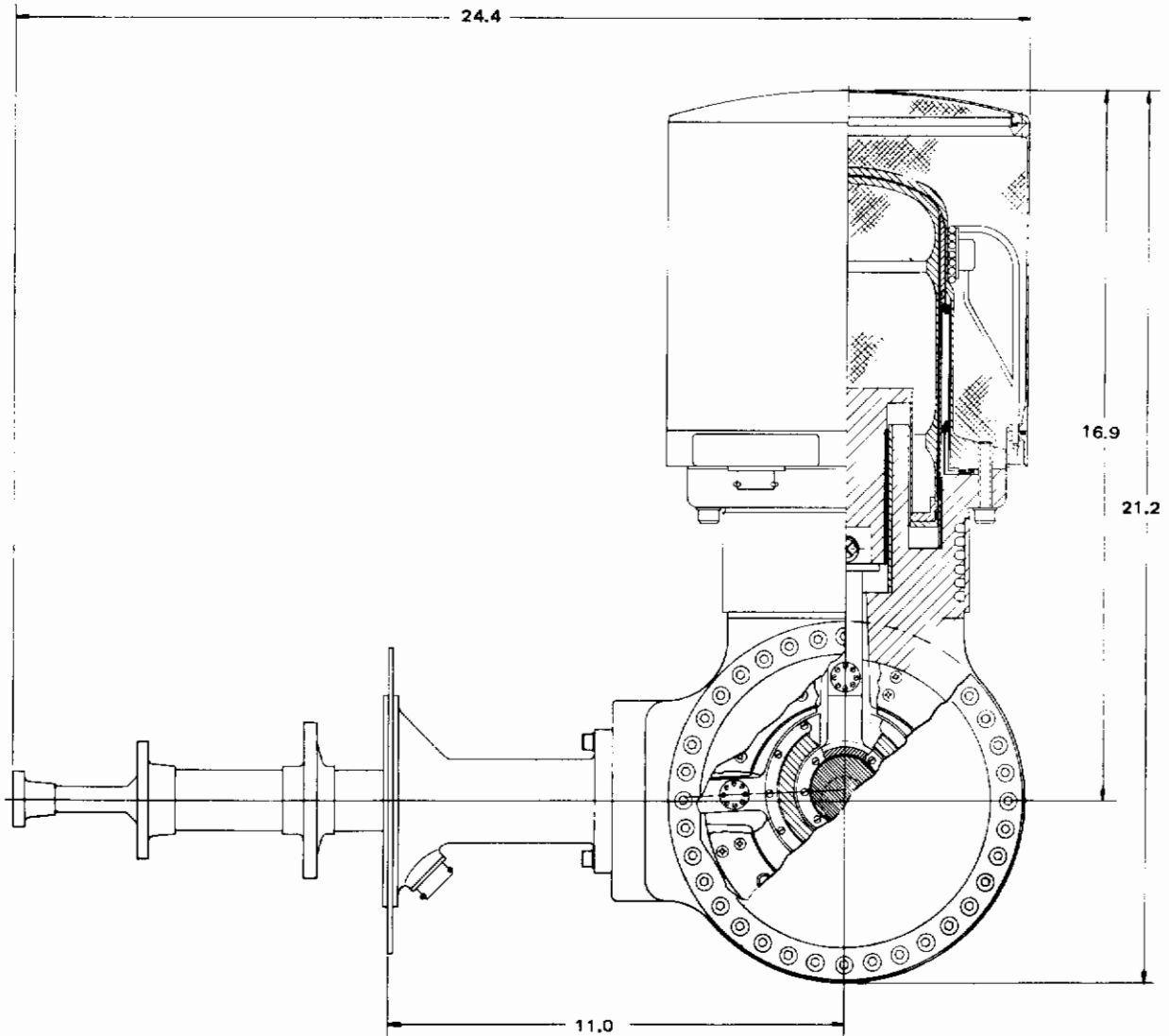

Figure 47. Folded crosshead support

while that of the larger support is 0.7. The rider extends only in the isothermal portion of the hot displacer in order to ensure minimum wear on 15-percent glass loaded teflon.

In this concept, the center of gravity of the displacer is in front of the displacer rider. In addition, the centerpoints of the two riders are separated by less than one half inch. Because of these two factors, a large turning moment is introduced and the displacer is forced into a tilted position, which will cause heavy wear on the opposite ends of the two riders rather than distributing the wear more uniformly along their lengths. This is a distinct disadvantage to this approach.

The folded crosshead design has essentially the same length and weight as the basic CCSS configuration. The increase in dead volume is only 1.5%. The fabrication of the housing requires some very precise and difficult machining operations and is somewhat complicated. Although this approach is viable, it is less attractive than others.

The loads on the riders can be reduced by supporting the displacer on both ends. In this approach, the rider wear does not result in a tilt in the axis of the displacer as does any form of cantilever support. One method of supporting the displacer is shown in Figure 48. The displacer is supported by two 15-percent glass filled teflon riders; one is at the crankcase end of the displacer and the other is on the end of a rod that extends from the heat input end of the hot displacer.

The rider on the displacer operates at crankcase temperature. The temperature of the rider on the extension rod was evaluated in relation to axial conduction in the extension and cylinder walls along with radial conduction through the helium gas. For an extension length of 4 inches (Figure 49) the calculated temperature of the rider is 185°F. Changing the relationship of the area for the axial conduction in the two extension elements has little effect in reducing this temperature. Increasing the length of the extension by 1 inch will reduce the temperature of the rider only to 172°F.

By utilizing 80°F wear rate data for calculating the wear of 15-percent glass filled teflon, the displacer rider would wear 0.003 inch and the extension rider would wear 0.012 inch. No metallic contact occurs because of the

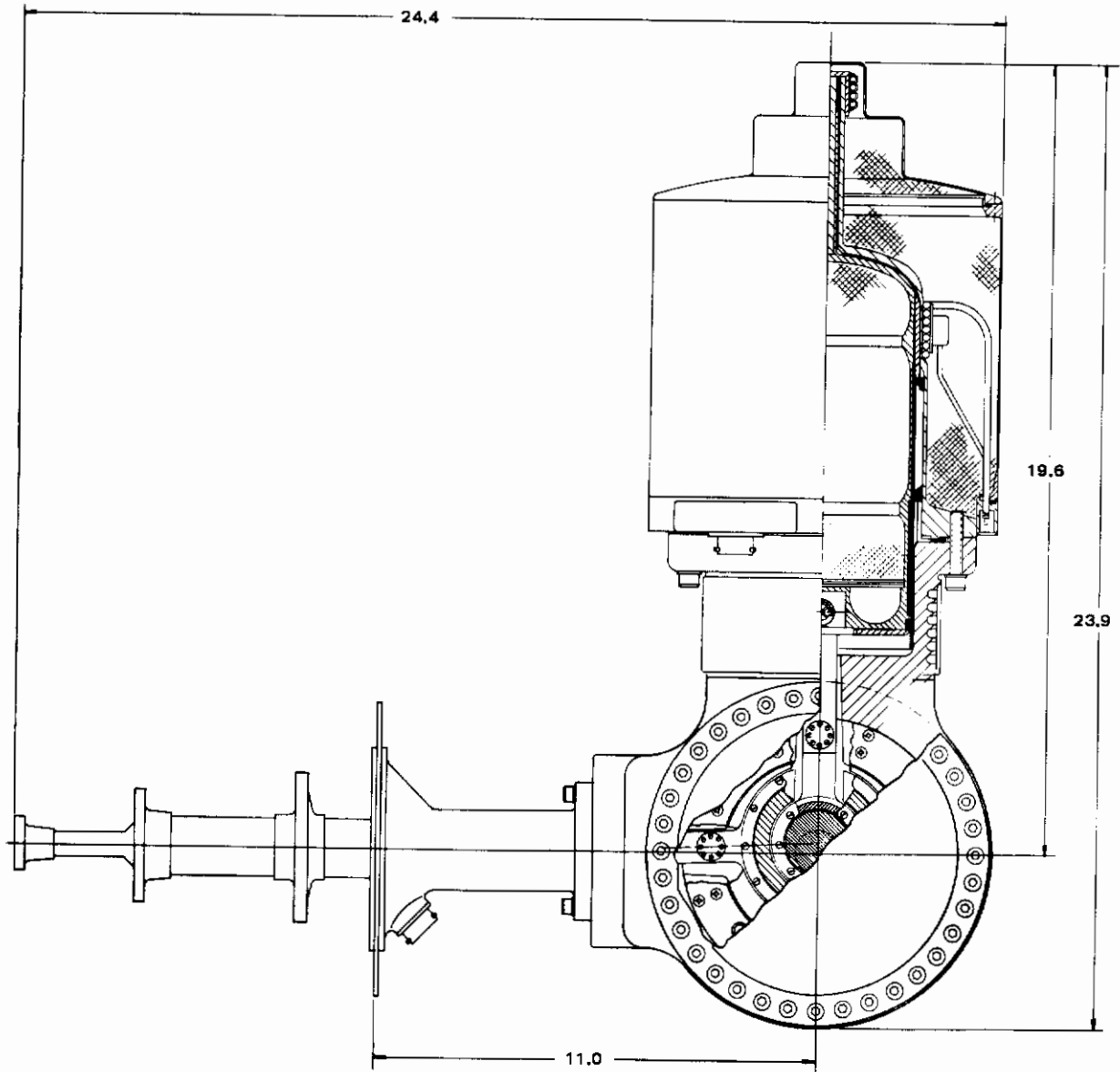

Figure 48. Simply supported hot displacer

0.016 inch clearance. No empirical data is available to evaluate the effect of the 100°F increase in operating temperature on the rider on the extension rod. Limited wear data is available on a polyimide material, which indicates that it will wear much less (approximately 4 times less) than 15-percent glass filled teflon at room temperature.

The wear theory that has been developed<sup>47, 48</sup> indicates a significant increase in the wear rate of one type of filled teflon material between 80° and 185° F but essentially no change in wear rate for the polyimide in this temperature range.

The simple support method results in a length of 23.9 inches from the top of the insulation can to the base of the crankcase. The weight is increased by about 5 lb. The dead volume is increased by only 0.4 percent, and an additional 25 watts of heater power is required. The end of the cylinder extension must be liquid cooled to maintain an acceptable exterior temperature for the extension and the top of the insulation can. Even with the penalties, this approach is acceptable.

The use of linear roller bearings has the potential for a support system that would exhibit minimal wear and maintain its initial axial alignment throughout its useful operating life. Two types of linear antifriction bearings are available commercially. In one type, the Thompson ball bushing, the balls continuously recirculate in grooves located axially along the length of the bearing. The other type, called Rotolin, has multiple circumferential rows of balls along its length. An annular retainer with pockets for the spheres keeps the balls in position. This bearing also permits rotation as well as translation.

In the past these bearings have usually been lubricated with a minimum amount of oil. One of the functions of the oil is to inhibit corrosion. Both manufacturers now suggest that their bearings could be dry lubricated. In fact, some ball bushings with light loads and at low speeds have needed no lubrication. Ball bushings with nylon balls are currently available, and Rotolin bearings with acetal separators are being tested. An alternative method of dry lubricating ball bushings would be to place a teflon ball between each metal ball. Rotolin bearings could use duroid retainers in the same manner that this material is employed in transfer lubricated ball bearings. Experimental verification of the operating life of linear bearings is required before they are used in a refrigerator. Figure 49 shows a

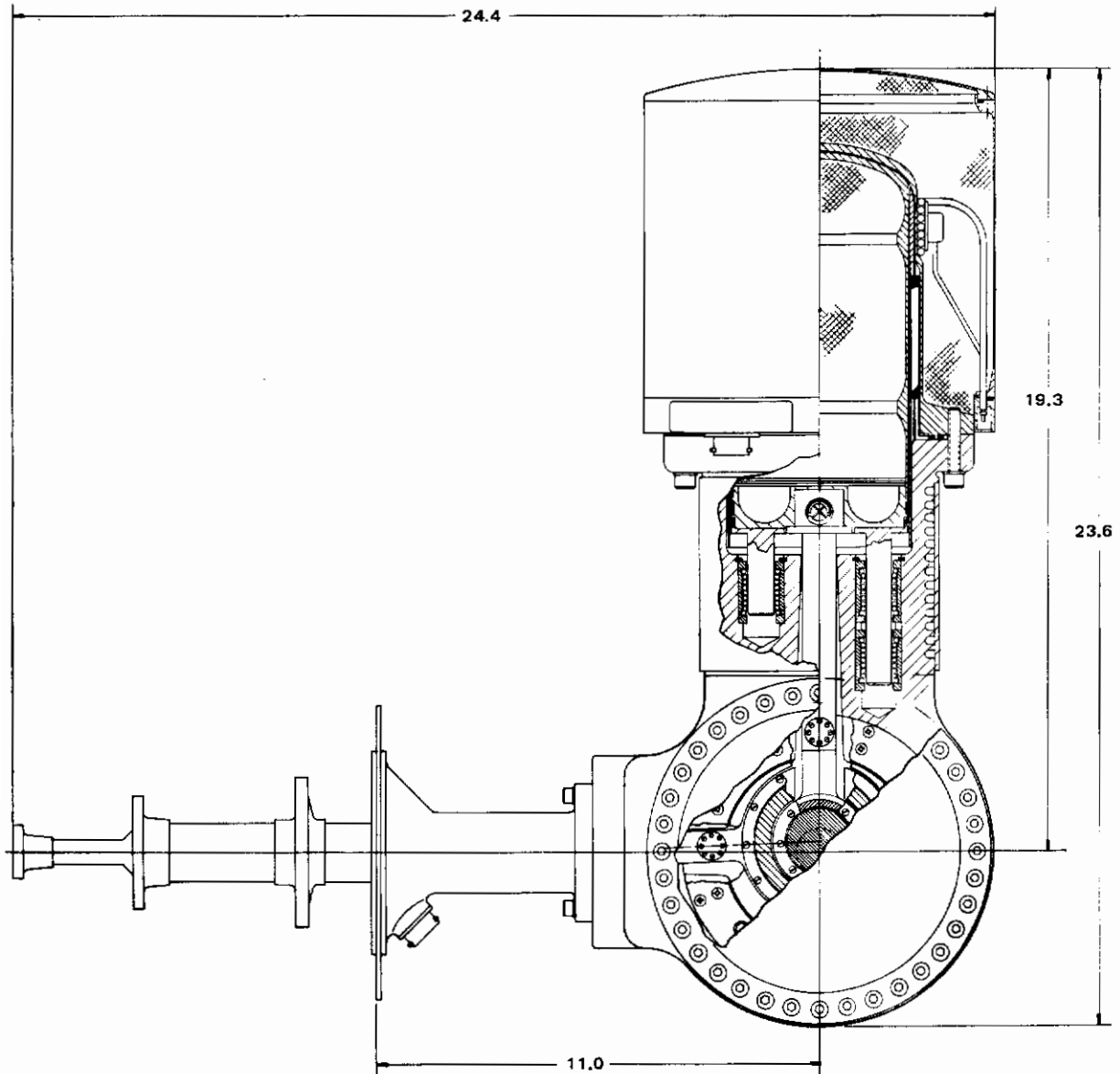

Figure 49. Multiple linear bushing support

method of supporting the hot displacer on dual shafts projecting from the displacer and utilizing multiple ball bushings. The alignment of the shafts and the bushings is extremely critical for smooth, low frictional operation. The portion of the housing containing the bushing (possibly an insert) and the base of the hot displacer must be made of the same material, and they must operate at the same temperature to prevent binding due to differential expansion.

Figure 50 shows a concept utilizing a single ball bushing to support the hot displacer. This arrangement is simpler and easier to manufacture than that with the multiple bushings. In this method, however, a large diameter bushing is required and has a significant open volume. This design increases dead volume more than any of the others that were investigated. The dead volume was not evaluated numerically for two reasons: (1) the life of dry lubricated bushings is unknown and (2) not enough dimensional information is available. The single linear ball bushing support does not increase the overall length of the hot cylinder or add significantly to the weight of the refrigerator. Although viable, this approach introduces several areas of concern.

Nine approaches for supporting the hot diaplacer without a hot rider ring have been reviewed:

- Magnetic support
- Pneumatic support
- Spherical support
- Wire support
- Cantilevered crosshead
- Folded crosshead
- Crosshead with opposite end support (simple support)



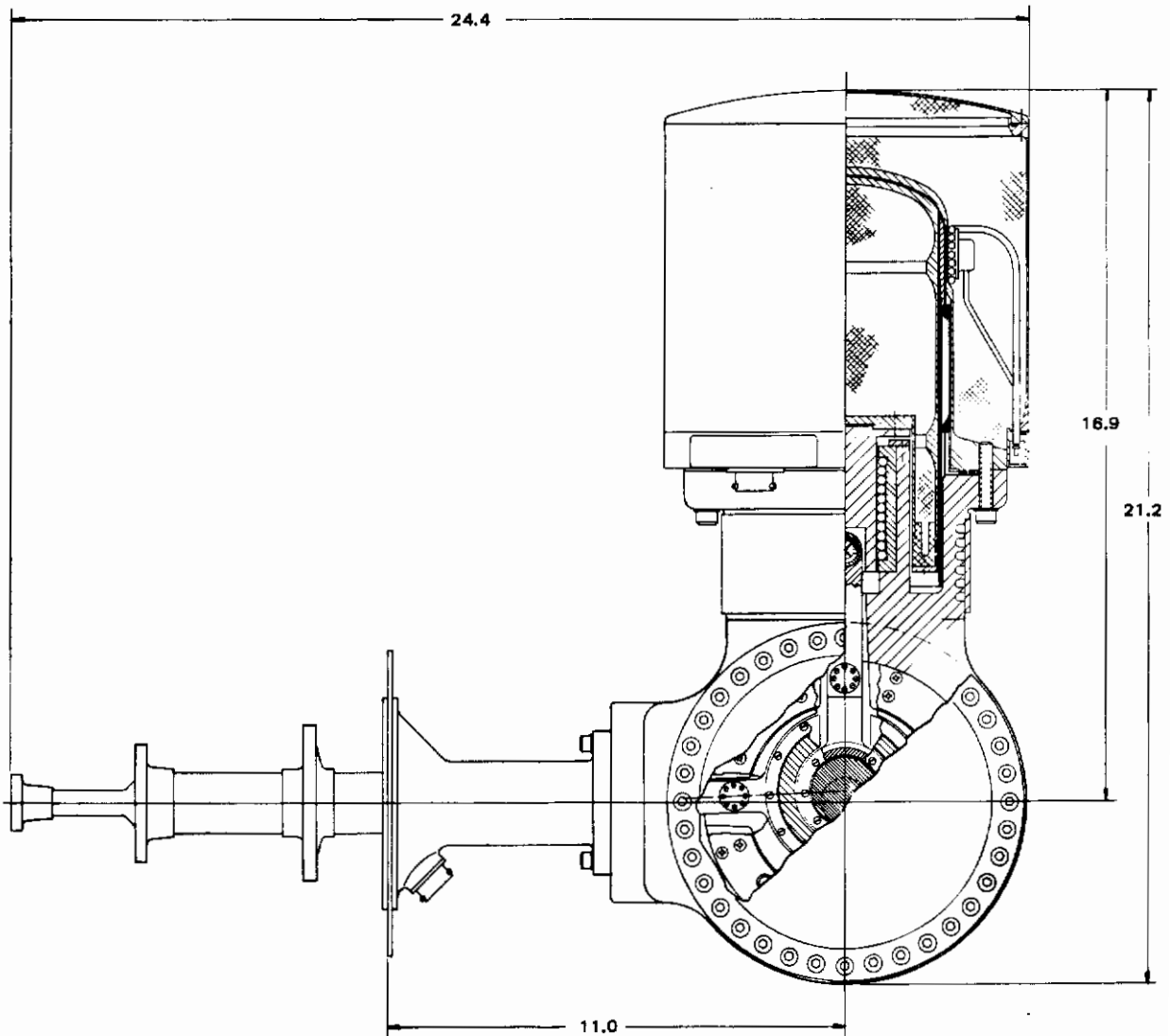

Figure 50. Single linear bushing support

- Multiple ball bushing
- Single linear bearing support

The first four of these have been ruled out as impractical.

Table 11 compares various parameters for the remaining five design concepts. The crosshead design affords the highest level of confidence. However, it increases the volume and weight of the refrigerator more than any other. The folded crosshead reduces these disadvantages but, because of the large turning moment that causes uneven wear, this approach is not recommended. The simple support design is the least complex and increases weight, volume, and power only moderately. The only adverse aspects of this design are the possible increase of rider wear at 185°F.

The ball bushing approaches are not recommended despite their zero wear advantage until more experimental work is done to verify that dry lubricated techniques can yield long operating life without detrimental effects to the rolling surfaces.

The above discussion shows that no design stands out as a significant step toward eliminating the hot rider to extend the operating life of a VM refrigerator. The extended crosshead is the approach affording the best chance of extending the life of VM refrigerator by operating it without a hot rider. The early results of the experimental verification of the new compact for the hot rider indicate that a long life hot rider can be developed; consequently, further study of a refrigerator without a hot rider is not recommended.

## 5. BRUSHLESS D-C MOTOR STUDY

Since brushless d-c motors offer some advantages over a-c induction motors, it has been suggested that a brushless d-c motor be substituted for the present a-c Hi Cap motor. The feasibility of doing so was studied, and it was concluded that such a substitution is technically feasible and advantageous; however, both the electronic and mechanical areas of the refrigerator would have to be significantly redesigned.

TABLE II. COMPARISON OF DIFFERENT DESIGNS TO ELIMINATE THE HOT RIDER

	Crosshead	Folded Crosshead	Simple Support	Multiple Ball Bushing	Single Linear Bearing
Additional heat input, watts	0	0	25	20	100
Additional dead volume, percent	0.4	1.5	0.4	Yes	Most
Maximum temperature of rider, °F	120	130	185	120	120
Maximum wear, inches	0.005	0.005	-0.012*	Negligible	Negligible
Width across hot cylinder, inches	25.5	21.2	23.9	23.6	21.2
Fabrication difficulty	Moderate	Complex	Moderate	Very Complex	Moderate
Additional cooling required	No	No	Yes	No	No
Additional weight, lb	20	Negligible	5	15	Negligible
Additional hot volume required	No	No	No	Probably	Yes

\* Based upon 80°F wear rate data

## A. Brushless D-C Motors

Brushless d-c motors are permanent magnet devices and are available in various numbers of poles and windings, various winding configurations, and where either the inner or outer member rotates. Figure 51 shows three common winding configurations.

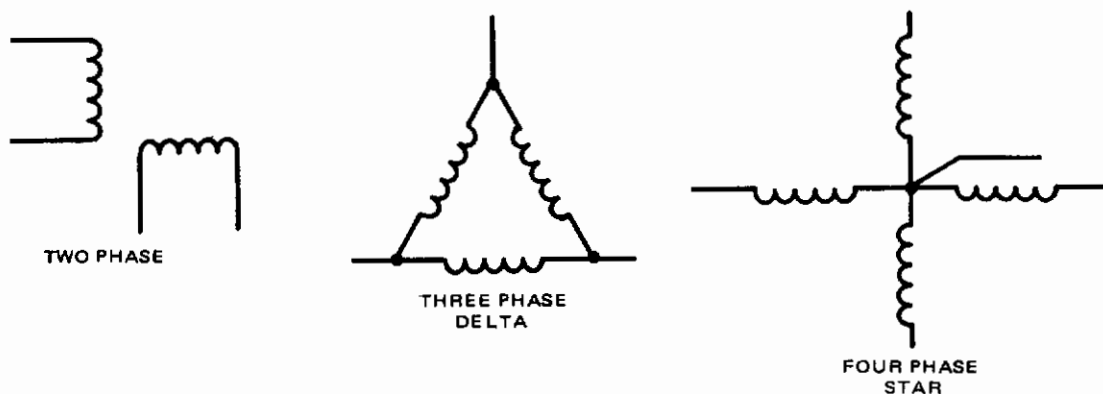

Figure 51. Three common winding configurations

The two-phase design can produce four magnetic vectors displaced by 90 degrees, depending on the winding energized and the polarity applied. The four-phase star provides the same four vectors; however, since the center point is always ground, each winding produces only one vector. The three-phase delta produces six vectors displaced by 60 degrees. This results in lower torque ripple than the two- or four-phase configuration. All of the windings in the three-phase delta are always energized, whereas only half of the two phase, and one-fourth of the four phase windings are energized at any given time. The two-phase configuration requires four bipolar switches; four-phase configuration requires four unipolar switches; and the three-phase configuration requires three bipolar switches. Both the two- and four-phase motors require two position sensors, while the three-phase motor requires three. Table 12 summarizes these features.

The three-phase delta winding is recommended. The efficient usage of windings and low torque ripple are considered significant enough to overcome the need for an extra sensor and slightly more complicated switching. Figure 52 is a simplified block diagram of the motor and commutator.

TABLE 12. CHARACTERISTICS OF VARIOUS BRUSHLESS MOTOR SCHEMES

Winding	Switches	Sensors	Lead Wires	Torque Ripple, percent	Efficiency
Two phase	Four bipolar	Two	Four	29	Good
Three phase delta	Three bipolar	Three	Three	15	Best
Four phase star	Four unipolar	Two	Five	29	Good

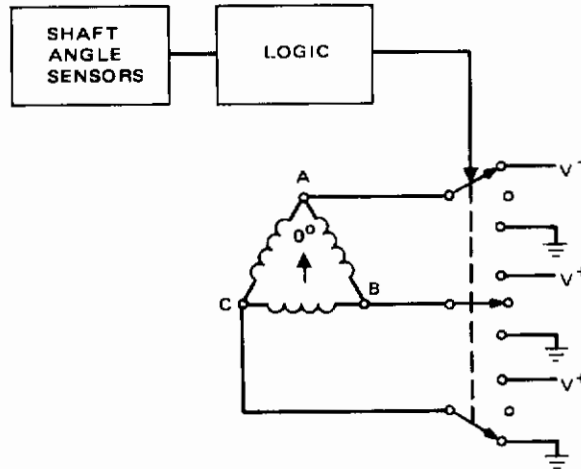

Figure 52. Block diagram of commutator

As shown, one part of the delta is connected to  $V^+$ , one is open, and one grounded. Table 13 shows six excitation patterns achieved in this manner.

### B. Position Sensor

A rotor position sensor is needed in order that the proper excitation pattern may be supplied. Possible devices for this are proximity detectors, brushes, Hall effect transducers, and optical sensors. Hall effect and optical sensors are favored on the basis of their simplicity and reliability features.

TABLE 13. THREE PHASE MOTOR EXCITATION PATTERNS

Electrical Vector, degrees	Point A	Point B	Point C	Excitation Angle, degrees
150	V <sup>+</sup>	Ground	Open	120 to 180
210	V <sup>+</sup>	Open	Ground	180 to 240
270	Open	V <sup>+</sup>	Ground	240 to 300
330	Ground	V <sup>+</sup>	Open	300 to 360
30	Ground	Open	V <sup>+</sup>	0 to 60

The main advantage of the Hall effect sensor is that it may be possible to mount it outside the helium environment; for such an installation no wires would need to pass through the crankcase wall. Its disadvantage is that processing electronics (zero crossing detectors and phase shifters) are needed to decode the position output.

Optical sensors do not require any processing circuits when operated over the Hi Cap temperature range. Bias current changes with temperature in the LED-phototransistor pair are not large enough to create problems in distinguishing between on and off states. However, the LED-phototransistor pair must be inside the crankcase; this results in two problems, viz., increased dead volume in the refrigerator and feedthrough for lead wires. A design where the optical emitter and sensor are separated by a chopper wheel would increase the dead volume in the crankcase and hence impair cryogenic performance. This difficulty can be overcome by a reflective arrangement where sections of the rotor are alternately reflective and nonreflective.

The passing of lead wires through the crankcase wall is not considered a major problem since the motor drive leads must pass through the crankcase wall. Therefore, wires could be routed through a hermetically sealed tube as they are in the present Hi Cap design. Optical sensors were chosen because they are easy to use, and experience on other programs has shown them to be reliable in the high pressure helium environment encountered in VM refrigerators.



## C. Motor Winding

After a three-phase motor and an optical position sensor had been selected, the motor operating voltage had to be chosen. Motor vendors indicate that a motor to meet the Hi Cap requirements could be wound for either 28 or 100 vdc, the two available Hi Cap power supply voltages. Since the commutator switches will be implemented with Darlington power transistors, the 100-volt configuration would yield significantly more efficient electronics. These transistors have a typical saturation (on) voltage of 1.5 to 2 volts. Since both legs to the motor must be switched, the voltage drop in the electronic switches would be 3 to 4 volts. This drop would be much more significant in a 28-volt design than in a 100-volt design.

The 28-volt design can be made more efficient by adding extra taps to the motor windings. Figure 53 illustrates the tapped and untapped configurations. The extra tap allows the collector of the driver transistor to operate at a higher voltage, which saturates the output transistor. This technique was used on another program and dramatically increased the efficiency of the commutator electronics.

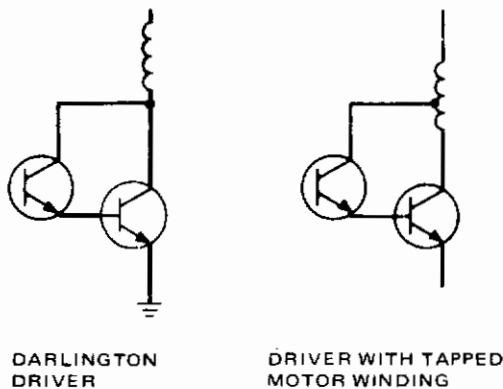

Figure 53. Use of motor winding taps

For a three-phase motor, six winding taps are required. Hence, it is more attractive to use the 100-volt supply and eliminate the need for these extra wires.

## D. Commutator

Figure 54 shows the electrical commutation scheme. Sensors a, b, and c are displaced from each other by  $120^\circ$ . The rotor surface is half

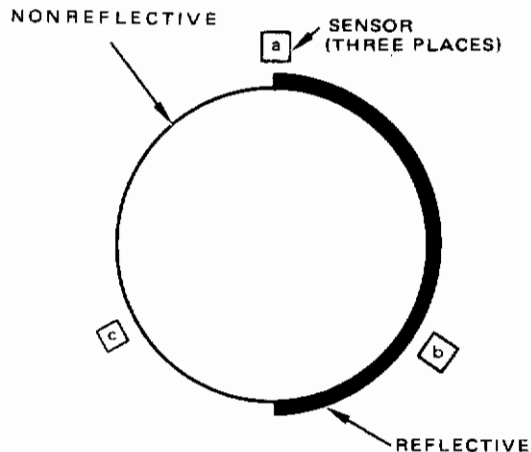

Figure 54. Recommended electrical commutation scheme

(180°) reflective and half nonreflective. Table 14 shows sensor output versus motor angle.

TABLE 14. SENSOR OUTPUT VERSUS MOTOR ANGLE

Angle, degrees	Sensor A	Sensor B	Sensor C
0 to 60	Off	On	Off
60 to 120	Off	On	On
120 to 180	Off	Off	On
180 to 240	On	Off	On
240 to 300	On	Off	Off
300 to 360	On	On	Off

From Table 13 and Table 14, it is easy to determine the logic to convert the sensor outputs shown in Table 14 to the required electronic switching given in Table 13 that results in the proper excitation pattern for each shaft angle. Note that the angles shown above are in electrical degrees. The number of electrical revolutions per revolution of the motor is determined by the number of poles in the motor. For example, for a 12-pole motor, 360 electrical degrees would correspond to 60 mechanical degrees, and the excitation patterns would recur six times per mechanical revolution. Spacing between the sensors for the 12-pole case would be 20 mechanical degrees. Figure 55 is a mechanical schematic showing the motor and position sensors.

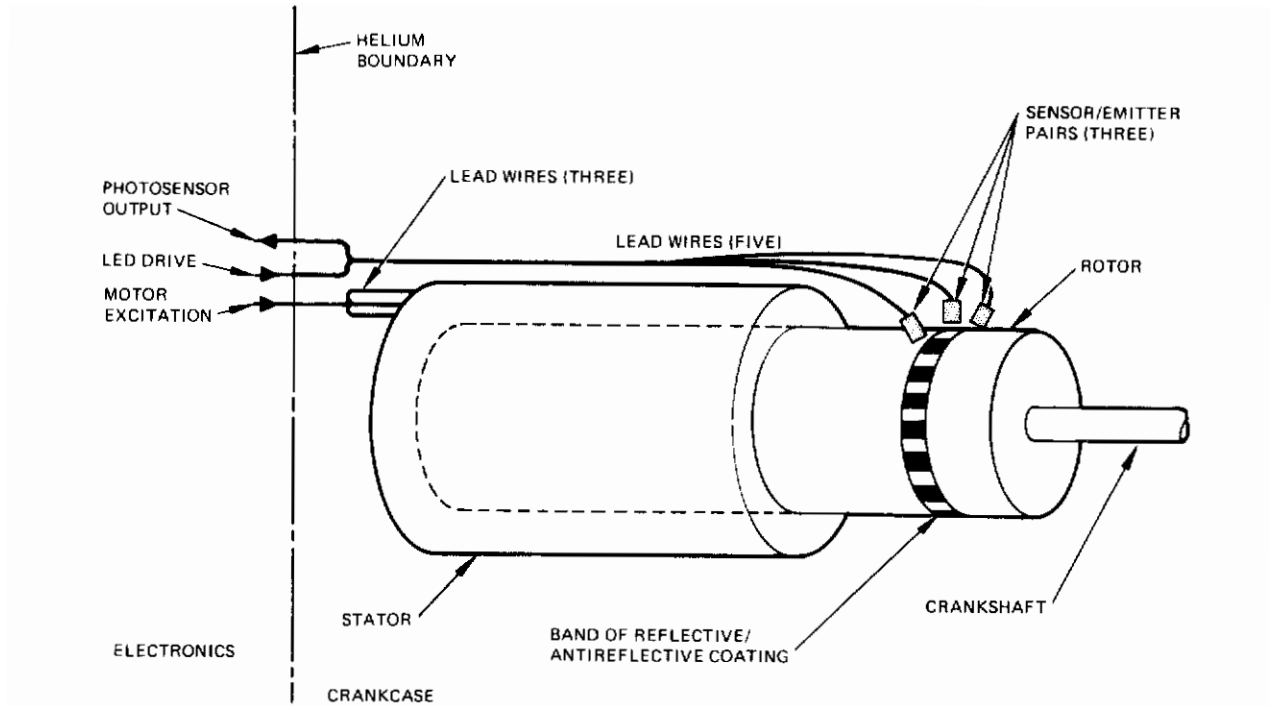

Figure 55. Mechanical schematic for recommended commutation scheme

## E. Speed Control

The Hi Cap motor speed varies between 160 and 300 rpm. For this variation using a brushless d-c motor, the speed is sensed and the drive from the commutator is adjusted to achieve the desired speed. There are two ways to adjust the drive to the motor:

1. Reduce the voltage
2. Reduce the commutation angle, i. e. ; apply drive power over only a prescribed portion of the commutation angle.

Although the second option is more efficient, the first option was chosen because it is more straightforward, has less torque ripple, and makes it easier to include current limiting devices to protect the motor magnets. In addition, the Hi Cap power limit (300 watts) can be achieved. Figure 56 is a block diagram of the motor speed control. Since the motor speed is directly proportional to the frequency of each sensor signal, one of the signals is picked off and sent through a voltage-to-frequency converter.

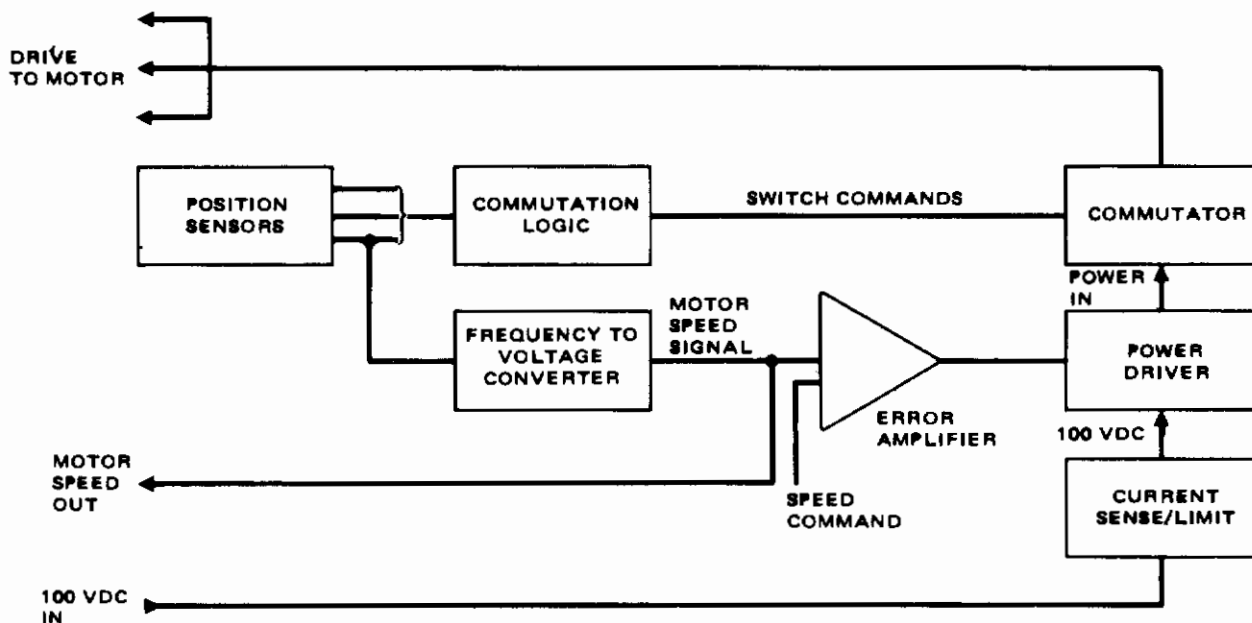

Figure 56. Block diagram of motor control

The resultant signal is directly proportional to motor speed. This signal is compared to the speed command, and the resulting error signal is used to control the d-c voltage input to the commutator. The 100-volt current is sensed and limited to 3.2 amperes to protect the motor magnets and commutator electronics.

#### F. Mechanical Considerations

The brushless d-c motor would be considerably smaller than the a-c induction motor now used in the Hi Cap machine. The Mag Tech 3350B-50 has an OD that is half that of the Hi Cap motor. Therefore, the crankcase would have to be designed to accommodate the d-c motor. Mounting, positioning, and adjusting mechanisms for the position sensors would have to be designed. In addition, some design changes would be required to bring the position sensor leads out of the crankcase.

#### G. Conclusion

A brushless d-c motor for Hi Cap machine has several important advantages over the a-c induction motor now used. The d-c motor is

# *Contrails*

smaller, weighs less, and uses 15 percent less power than the a-c induction motor uses. The brushless d-c design greatly facilitates the control and readout of motor speed. The recommended design includes a closed loop speed control that is more easily achieved with a d-c motor. On the negative side, the brushless d-c design requires a position sensor in the crankcase, additional feedthroughs across the helium boundary, and somewhat more complex electronics. Hughes believes that the advantages of the brushless d-c motor merit the pursuit of a detail design effort to incorporate it in a Hi Cap type machine for further evaluation/development.

## SECTION VII CONCLUSIONS AND RECOMMENDATIONS

So far, the effort on the program has been expended primarily on determining what to test, the approach on how to test, and the preparation of test hardware. The amount of testing to date has been minimal. However, early test results of the new compact material for the hot rider indicate that a long life hot rider can be realized.

The results of the riderless VM design work, which was completed during this report period, show that no design stands out as a significant step toward eliminating the hot rider ring as a means of extending the operating life of a VM space refrigerator. In fact, the easier solution appears to be to develop the long life rider ring.

The d-c brushless motor study was also completed during this report period. The study indicated that a d-c brushless motor with three-phase delta windings, optical rotor position sensors for the commutation, and 100-vdc windings would be half the size of the present a-c Hi Cap motor and consume 15 percent less power than the Hi Cap motor needs. To accomplish this, five additional lead wires or a total of eight wires would be needed to cross the helium boundary, and the motor control electronics would necessarily become more complex. (See last sentence of page 119.)

As mentioned earlier, the testing to date represents only beginning efforts. The primary objective of the program, to experimentally verify the long term operating capabilities of dry lubricated VM cryogenic refrigerators, remains.

The investigation of alternatives for extending the useful life of the refrigerator by developing the critical components that are identified during this program to be life limiting should also be undertaken as an add-on to this program or in separate programs.



APPENDIX A  
TEST PLAN FOR VUILLEUMIER COOLER WEAR RATE  
TEST PROGRAM

TEST PLAN  
FOR  
VUILLEUMIER COOLER WEAR RATE  
TEST PROGRAM

CDRL ITEM A004

Exhibit A

Contract No. F33615-75-C-3117

Project No. 2126

December 1975

Electro-Optical Division

HUGHES AIRCRAFT COMPANY • CULVER CITY, CALIFORNIA

## TABLE OF CONTENTS

	Page No.
1. SCOPE	1
1.1 Purpose	1
1.2 Objective	1
2. APPLICABLE DOCUMENTS	1
3. GENERAL REQUIREMENTS	3
3.1 Identification of test units	3
3.1.1 77°K VM Cooler	3
3.1.2 Hi Cap VM Cooler	3
3.1.3 Dynamic test module	3
3.2 Test conditions	3
3.2.1 Accuracy of test apparatus	6
3.2.2 Test facility	6
3.3 Performance of test	6
3.3.1 Pretest data	6
3.3.2 Installation and pretest performance	6
3.3.3 Performance check during test	6
3.3.4 Post-test data	7
3.3.5 Test data	7
3.3.6. Failure Criteria	7
3.3.7 Log Books	7
4. TEST EQUIPMENT	9
4.1 77°K VM Cooler	9
4.2 Hi Cap VM Cooler	9
4.3 Dynamic test module	11

	Page No.
5. INSTRUMENTATION	12
5.1 77°K VM Cooler	12
5.2 Hi Cap VM Cooler	12
5.3 Dynamic test module	13
6. TEST DESCRIPTION	14
6.1 Evaluation of critical components	14
6.1.1 Hot rider rings	14
6.1.2 Ambient and cold rider rings	14
6.1.3 Dynamic seals	14
6.1.4 Bearings	14
6.1.5 Flexural pivots	15
6.1.6 Heaters	15
6.1.7 Temperature sensors	15
6.1.8 Refrigerant	15
6.1.9 Hot Cylinders and Hot Cylinder Liners	15
6.2 Performance tests	16
6.2.1 Cold end temperatures	16
6.2.2 Crankcase temperatures	16
6.2.3 Hot cylinder temperature	16
6.2.4 Pressure	16
6.2.5 Motor speed	16
6.2.6 Input power	16
6.2.7 Cooldown time	17
6.2.8 Coolant temperature	17
6.2.9 Coolant flow	17

		Page No.	
7.	TEST PROCEDURE	18	
	7.1	77°K VM Cooler	18
	7.2	Hi Cap VM Cooler	20
	7.3	Dynamic test module	22
8.	DATA	24	
	8.1	Test data acquisition	24
	8.2	Components evaluation	24
	8.3	Wear Projections	24
9.	SCHEDULE	25	
	9.1	Test schedule	26
10.	SAFETY	27	
	10.1	Safety factors	27
11.	QUALITY	27	
	11.1	Quality Requirements	27
	11.2	Documentation	27
	11.3	Traceability	27
ATTACHMENTS:			
	PQR E012	28	
	Sample Data Sheets	32	

TEST PLAN

FOR

VUILLEUMIER COOLER WEAR RATE

TEST PROGRAM

1. SCOPE

1.1 Purpose - This test plan defines the tests that will provide experimental verification of the projected long term operating capabilities of dry lubricated, VM cycle, cryogenic refrigerators which will ultimately be used in a space environment.

1.2 Objective - The accelerated tests conducted will be used to gather information to empirically develop wear rate data related to critical cooler components and materials which have the best long term operating potential. The high capacity cooler will be incrementally tested for extended periods to measure wear rates and contamination effects.

2. APPLICABLE DOCUMENTS

The following documents, of the issue in effect on the date of the contract, form a part of this test plan to the extent specified herein:

SPECIFICATIONS

MIL-C-45662 Calibration System Requirements

STANDARDS

MIL-STD 454 General Requirements for  
Electronic Equipment

MIL-STD-810 Environmental Test Methods



# Contracts

## DRAWINGS

X3243002-100	VM Refrigerator (GFE 77°K VM)
3273700-100	Long Life, High Capacity Space- craft VM Cooler
Unassigned	Dynamic Test Module

## OTHER DOCUMENTS

Exhibit A of Contract F33615-C-3117, Project No. 2126,  
dated 2 June 1975; AFSC Number DI-T-3708/T-108-2/M,  
dated 1 November 1971.

3. GENERAL REQUIREMENTS

3.1 Identification of test units - The three configurations of test units which will be used as test vehicles to evaluate life capabilities of wear components are as follows:

3.1.1 77°K VM Cooler - The three GFE 77°K VM coolers S/N's 1, 2 & 3, to be used for component selection and initial wear rate tests are per Hughes Aircraft Company (HAC) drawing X3243002-100 and shown in Figure 3-1.

3.1.2 Hi Cap VM Cooler - The long life, high capacity space-craft VM cooler, S/N 2, is identified by HAC drawing 3273700-100 and is shown in Figure 3-2. Incremental tests will be performed of this unit to verify operating life expectancy.

3.1.3 Dynamic Test Module - A special test module in the 600 to 900 RPM range will be designed, fabricated and utilized for accelerated wear rate tests of selected life limiting cooler components. Figures 3-3 and 3-4 illustrate this accelerated wear rate test module as it is now envisioned. A complete description of the design is to be presented at a design review prior to start of this test.

3.2 Test conditions - Unless otherwise specified herein, measurements and tests shall be made at standard ambient conditions. Standard ambient conditions are:

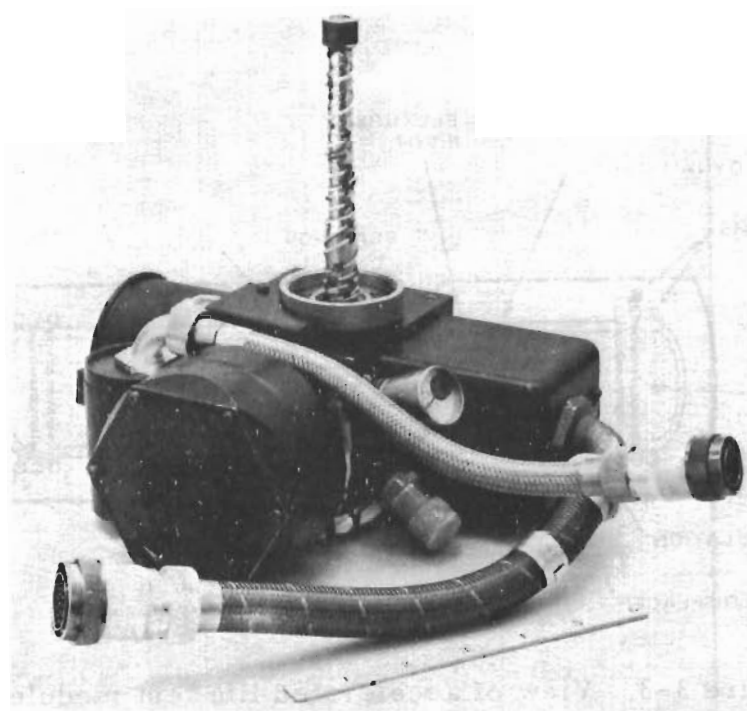

Figure 3-1. 77°K airborne VM refrigerator (71-7232)

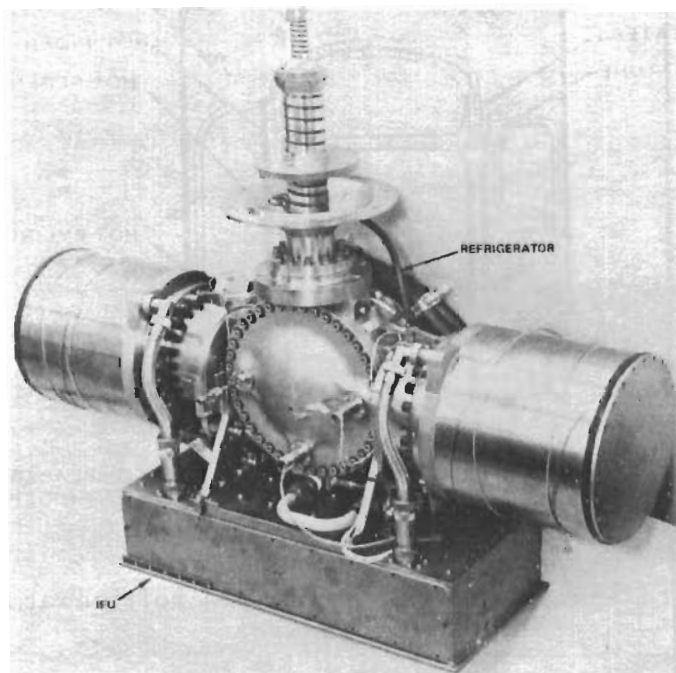

Figure 3-2. Three-stage high capacity spacecraft refrigerator (73-21547)

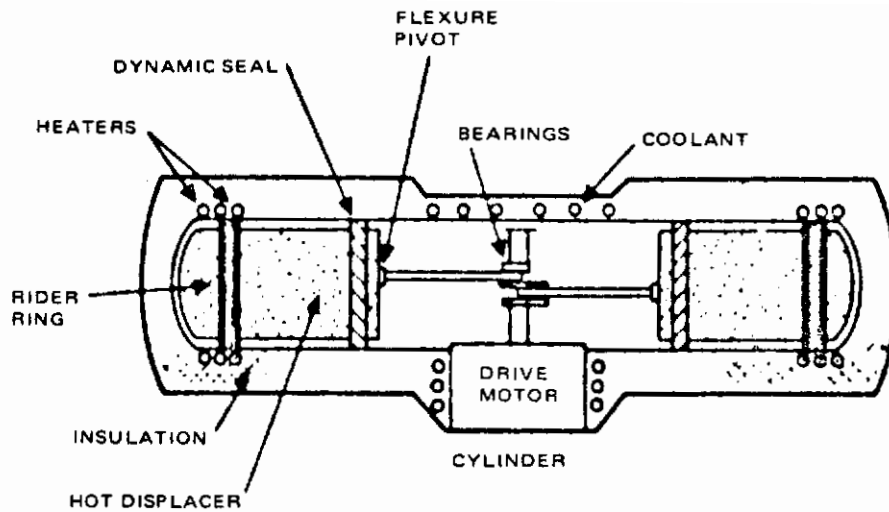

Figure 3-3. View of accelerated life test module

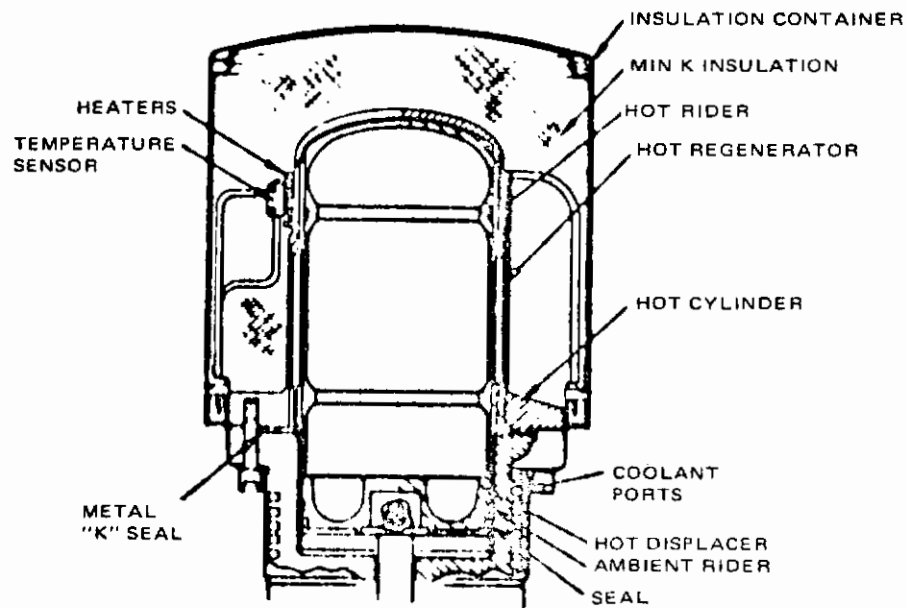

Figure 3-4. Cutaway view of VM refrigerator hot displacer area

Temperature	$23^{\circ} \pm 10^{\circ}\text{C}$ ( $73^{\circ} \pm 18^{\circ}\text{F}$ )
Relative humidity	50 percent $\pm$ 30 percent
Atmospheric pressure	$725 \begin{smallmatrix} +50 \\ -75 \end{smallmatrix}$ mm Hg ( $28.5 \begin{smallmatrix} +2.0 \\ -3.0 \end{smallmatrix}$ in Hg)

3.2.1 Accuracy of test apparatus - The accuracy of instruments and test parameters, shall be verified and shall satisfy the requirements of MIL-C-45662. Calibration accuracy, certification and maintenance requirements are to be performed by the HAC Calibration and Measurement Standards Laboratory.

3.2.2 Test facility - The tests will be conducted at the HAC Cryogenics and Thermal Controls Department, Culver City, California, and/or at other approved outside facilities.

3.3 Performance of Test - HAC shall provide the necessary personnel, materials and supplies to perform the tests described herein. Material selection shall be based on analysis, test and previous experience on similar equipment.

3.3.1 Pretest data - Prior to proceeding with any of the tests specified herein, sufficient measurements and observations of the critical parts and components shall have been made and recorded in order to determine wear rates. (See attachments to this test plan for sample data sheets).

3.3.2 Installation and Pretest performance - The test unit shall be installed in a manner specified in the test procedure, section 7, and a pre-test performance record shall be made to determine satisfactory operation of the test unit.

3.3.3 Performance check during test - During the wear rate test period, suitable performance checks shall be made to determine whether extended testing is producing changes in performance when compared with pretest data.

3.3.4 Post-test data - At the completion of each wear rate test period, a post-test performance record shall be made to determine performance degradation. The test unit shall then be disassembled as required for appropriate examinations to measure component wear rates and/or effects of any contamination.

3.3.5 Test data - The test data shall include complete identification, measurements and observations of critical wear rate parts and components as well as the performance history of the test units. The test record shall contain a date and signature block for certification of the test data.

3.3.6 Failure criteria - The test units shall have failed the test and/or test shall be interrupted when any of the following occur:

- (a) Monitored functional parameters deviate beyond acceptable limits established by Table 3.1.
- (b) Catastrophic or structural failure
- (c) Malfunction, including excessive noise, unexpected failures of critical wear rate components or essential supporting equipment.

Should a test unit fail or an interruption of the test during a test increment occur, a complete description of the failure and proposed disposition action shall be made available to the Air Force Flight Dynamics Laboratory (AFFDL) as soon as possible.

3.3.7 A log book containing all component measurement data and performance data shall be maintained for each machine under test.



Table 3.1 ACCEPTABLE LIMITS

	<u>Parameter</u>	<u>Limits</u>
A. 77°K Cooler	Hot end temperature Crankcase temperature Motor speed Cold end temperature	> 1200° F > 160° F < 450 RPM > 100° K
B. Hi Capacity Cooler	Hot cylinder temperature Crankcase temperature Motor speed 1st Stage temperature 2nd Stage temperature 3rd Stage temperature Coolant flow	> 1360° F > 165° F 300 ± 50 RPM > 100° K > 75° K > 30° K < 2.5 GPM
C. Test Module	Hot cylinder temperature Crankcase temperature Motor speed Coolant flow	> 1360° F > 165° F 750 ± 50 RPM < 2.5 GPM

4. TEST EQUIPMENT

4.1 77°K VM Cooler - The following list of test equipment, or the equivalent, shall be used where applicable in performing the tests described herein:

<u>Instrument</u>	<u>Manufacturer</u>	<u>Model</u>
DC Power Supply	Lambda	LB-704-FM-OV-CS
DC Power Supply	Hewlett-Packard	6206B
Potentiometer	Leeds & Horthrup	8857C
Potentiometer	Thermi Electric	7551-59
Amplifier	Dymec	2461A
VOM	Triplett	630
DC Voltmeter	Hewlett-Packard	412A
DC Ammeter	Weston	931
Timer	Lab Chron	1401
Digital Voltmeter	Data Precision	2540A1
Tachometer	API	603
Vacuum Station	Veeco	VS-9A-200
DC Milliammeter	Hewlett-Packard	428A
Wattmeters	Weston	432
STE Console	HAC	

4.2 Hi Cap VM Cooler - The following list of test equipment, or the equivalent, shall be used where applicable in performing the tests described herein:

# Contrails

<u>Instrument</u>	<u>Manufacturer</u>	<u>Model</u>
DC Power Supply	Lambda	LB-704-FM-OV-CS
DC Power Supply	Hewlett-Packard	6267B
DC Power Supply	Hewlett-Packard	6242A
Variac	Powerstat Company	116
Potentiometer	Leeds & Northrup	8857C
Potentiometer	Thermo Electric	7551-59
Recorder	Moseley	7101B
Amplifier	Dymec	2460C
VOM	Triplet	630
DC Voltmeter	Parker Instrument	S35
DC Ammeter	Parker Instrument	S35
Timer	Lab Chron	1401
Digital Voltmeter	Data Precision	2540A1
Tachometer	API	603
Vacuum Station	Veeco	VS-9A-200
Heat Exchanger	Electro Impulse	C9532
Data Acquisition	Hewlett Packard	E17-3480B
Equipment		
Time Code Generator	A. W. Haydon Co.	K42602-P2
STE Console	HAC	

4.3        Dynamic test module - The same test equipment, or equivalent, used to test the Hi Cap VM cooler will be used to test the dynamic test module.

## 5. INSTRUMENTATION

5.1 77°K VM Cooler - The following minimum instrumentation will be provided on each test unit for taking measurements of the most significant operational parameters:

<u>Parameter</u>	<u>Nominal Range</u>	<u>Tolerance</u>
(a) Temperature: Cold end	60 - 300°K	<u>+1°K</u>
(b) Temperature: Crankcase	30 - 150°F	<u>+5°F</u>
(c) Temperature: Hot Cylinder	32 - 1400°F	<u>+20°F</u>
(d) Pressure:	0 - 1000 psig	<u>+25 psi</u>
(e) Motor speed	0 - 700 rpm	<u>+10 rpm</u>
(f) Load heater	0 - 5 watts	-
(g) Elapsed time	0 - 9,999 hrs	-

5.2 Hi Cap VM cooler - The existing instrumentation on the Hi Cap VM cooler will be used for the incremental endurance tests.

<u>Parameter</u>	<u>Nominal Range</u>	<u>Tolerance</u>
a) Temperature: 3rd cold stage	9 - 325°K	<u>+1°K</u>
b) Temperature: 2nd cold stage	9 - 325°K	<u>+1°K</u>

# Contracts

<u>Parameter</u>	<u>Nominal Range</u>	<u>Tolerance</u>
c) Temperature: 1st cold stage	9 - 325°K	<u>+1°K</u>
d) Temperature: Crankcase	32 - 150°F	<u>+3.5°F</u>
e) Temperature: Inlet coolant line	32 - 125°F	<u>+3.5°F</u>
f) Temperature: Outlet coolant line	32 - 150°F	<u>+3.5°F</u>
g) Temperature: Hot cylinders	35 - 1350°F	<u>+20°F</u>
h) Pressure	0 - 1500 PSI	<u>+30 PSI</u>
i) Motor speed	150 - 330 RPM	<u>+2 RPM</u>
j) Load heater: 1st stage	0 - 18 Watts	-
k) Load heater: 2nd stage	0 - 15 Watts	-
l) Load heater: 3rd stage	0 - 1 Watt	-
m) Elapsed time	0 - 9,999	-

5.3 Dynamic Test module - The instrumentation to be provided on the dynamic test module shall be similar to that provided on the Hi Cap VM cooler minus the cold end instrumentation.



## 6. TEST DESCRIPTION

6.1 Evaluation of critical components - Utilizing the specified test units, the life limiting hot displacer rider rings will be evaluated along with other critical active components listed herein. All physical dimensions, weights, surface finish and other mechanical measurements where applicable, will be measured before and after a given test period by the HAC primary standards laboratory. Current precision measurement techniques for metrology shall be applied.

6.1.1 Hot rider rings - Each hot rider ring will be completely defined, prior to installation in a test unit, by its documented record of vendor certification of material, physical dimensions, weight and density. At specified test intervals, the unit will be disassembled and the parameters associated with hot rider ring wear rate will be measured.

6.1.2 Ambient and cold rider rings - Where practical, the weights, dimensions and condition of the wear surfaces of new ambient and cold rider rings will be measured prior to start of test and their material recorded. These measurements will be compared to post-test data for measurable wear.

6.1.3 Dynamic seals - Besides material, weight and physical dimensions, the dynamic seals will be measured for leakage across their lips, before and after each test period, or when test unit capacity degrades beyond acceptable limits as specified by the cognizant HAC engineer.

6.1.4 Bearings - All bearings shall be traceable back to their vendors for preload and lubricant, if any, and for their ball separator materials. Torque tests shall be made before and after completion of

final tests to help in analyzing life data and any changes that may have occurred to the unit input loads. Upon completion of the tests, each bearing shall be analyzed by the HAC bearing laboratory.

6.1.5 Flexural pivots - At the end of each test period, the flexural pivots in the Hi Cap machine and test module will be visually examined under a microscope for any evidence of mechanical failure.

6.1.6 Heaters - X-rays shall be made before assembly, if possible, and resistance measurements shall be made before and after each test period.

6.1.7 Temperature Sensors - The temperature sensors for the hot end shall be calibrated with a known standard prior to start of initial assembly. Before and after each incremental test period, the sensors shall be compared to each other for evidence of any significant changes.

6.1.8 Refrigerant - Before and after each Hi Cap test increment, a gas sample shall be withdrawn from the test unit. A mass spectrometric analysis of the gas shall then be made to determine the change in purity of the refrigerant.

6.1.9 Hot Cylinder and Hot Cylinder Liners. - Each hot cylinder or hot cylinder liner will be defined, prior to installation in a test unit, by its documented record of material, coating if any, inside diameter and surface finish. At specified test intervals, the unit will be disassembled and the parameters associated with cylinder wear will be measured.

6.2 Performance tests - Prior to, during and after each test period, performance parameters of the test units shall be measured and recorded as specified. In addition, protective devices to prevent test unit failure under out-of-tolerance conditions shall be verified during pretest.

6.2.1 Cold end temperatures - Cold end temperatures shall be defined as the temperature for each stage of the cold end for a given external heat load on each stage. A sensing element shall be mounted on each stage for measuring temperatures.

6.2.2 Crankcase temperature - The average heat rejection temperature shall be measured by monitoring the temperature sensing elements mounted on the crankcase.

6.2.3 Hot cylinder temperature - The temperature of each hot cylinder shall be measured by the temperature sensing elements mounted on the dome or heater of the hot cylinder assembly.

6.2.4 Pressure - The pressure of the refrigerant or working fluid in the test unit shall be measured by means of a strain gage pressure transducer mounted on the crankcase.

6.2.5 Motor speed - The rotational speed of the motor shall be monitored by considering the variations in the working fluid pressure or by the voltage pips from the pip coil.

6.2.6 Input power - The power consumption of the test unit shall be determined by measuring the voltages and currents of the various forms required to operate the unit.

6.2.7 Cooldown time - Although there is no specific cooldown time requirement, the time taken by the cold end to go from ambient to operating temperatures shall be monitored at the beginning of each test period.

6.2.8 Coolant temperature - When a test unit requires an external heat exchanger, two temperature sensing elements shall be used to monitor the coolant fluid temperature. One sensor shall be attached to the test unit's inlet coolant line and the other attached to the outlet coolant line.

6.2.9 Coolant flow - The flow of the external heat exchanger coolant shall be measured by a flow meter located in the heat exchanger where applicable.

7. TEST PROCEDURE

7.1 77°K VM Cooler - In all tests, the cooler will be mounted on a fixture with a test dewar attached to the cold end. Unit orientation and hot rider ring/cylinder wall material combination shall be as specified in the test matrix shown in Table 7-1. The general test procedure to be repeated for each unit shall be as follows:

- Step 1 - Fill out data sheets on measurements and observations of wear rate parts and components. Place sheets in log book.
- Step 2 - With the unit installed in its proper orientation per Table 7.1 pretest performance parameters shall be obtained and recorded on the data sheet.
- Step 3 - The unit shall be continuously operated for a period of 3 months with no external heater load applied to the cold end except when taking performance data.
- Step 4 - At the end of the test period, a post-test performance test shall be made and recorded on the data sheet in the log book.
- Step 5 - The test unit shall be disassembled as required for component wear rate examinations and then prepared as necessary for its next test.

Table 7-1. 77°K VM Cooler Test Matrix

Test No	Cooler S/N	Rider Ring Material	Cylinder or Coating Material	Hot Cylinder Orientation
1	1	6-84-1	Inconel 718	Horizontal
2	2	6-84-1	Ion-Plated Alumina	Horizontal
3	3	108	Ion-Plated Alumina	Horizontal
4	1	6-84-1	Inconel 718 Ion-Plated Alumina	Horizontal
5	2	6-84-1	Ion-Plated Alumina	Horizontal
6	3	6-84-1	Alumina	Horizontal
7	1	6-84-1	Inconel 718	Vertical
8	2	6-84-1	Ion-Plated Alumina	Vertical
9	3	6-84-1	Ion-Plated Alumina	Vertical
10	2	4-122-1	Ion-Plated Alumina	Horizontal
11	3	PM-107	Ion-Plated Alumina	Horizontal
12	2	4-122-1	Ion-Plated Alumina	Horizontal
13	3	PM-107	Ion-Plated Alumina	Horizontal
14	2	4-122-1	Ion-Plated Alumina	Vertical
15	3	PM-107	Ion-Plated Alumina	Vertical
16	2	108	Ion-Plated Alumina	Horizontal
17	3	108-67	Ion-Plated Alumina	Horizontal
18	2	108	Ion-Plated Alumina	Horizontal

7.2 Hi Cap VM cooler - Incremental endurance tests of the Hi Cap VM cooler shall consist of four increments of 2,500 hours each. The cooler hot rider ring/cylinder wall material combination shall be as specified in the test matrix shown in Table 7-2. The general test procedure to be followed for each test increment is:

- Step 1 - Fill out data sheets on measurements and observations of wear rate parts and components. Place sheets in log book along with gas sample analysis.
- Step 2 - With the unit installed in position 1 of Figure 7-1, pretest performance parameters shall be obtained and recorded on the data sheet.
- Step 3 - The unit shall be continuously operated for a period of 3 weeks with cold cylinder electrical heaters applied as long as they are operable.
- Step 4 - Rotate the cooler to position 2 of Figure 7-1 and repeat step 3.
- Step 5 - Rotate the cooler back to position 1 and repeat step 3 through 5 for the duration of the incremental test period of 2,500 hours.
- Step 6 - At the conclusion of the test period, a post-test performance test shall be made and recorded on the data sheet in the log book.
- Step 7 - Sample gas shall be withdrawn from the unit for refrigerant contamination analysis.
- Step 8 - The test unit shall be disassembled as required for component wear rate examinations and then prepared as necessary for its next test.



# Contrails

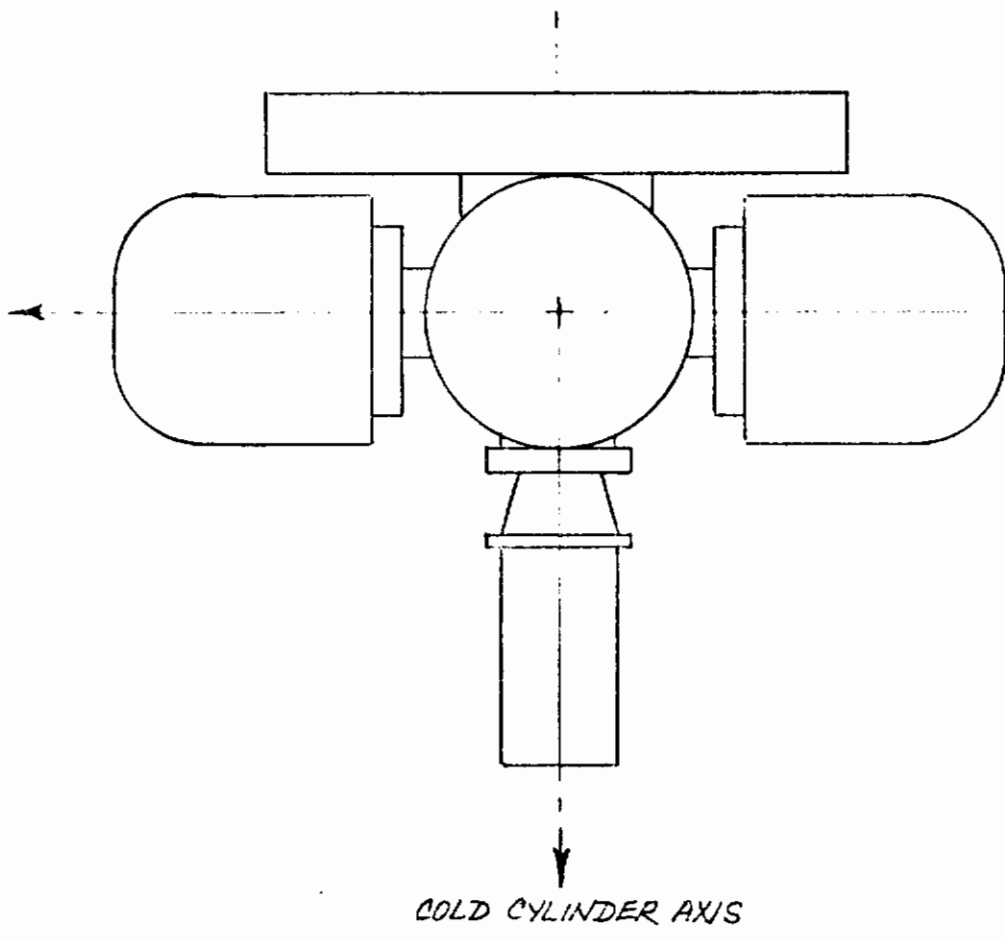

POSITION	COLD CYLINDER	HOT CYLINDER
1	DOWN	HORIZONTAL
2	UP	HORIZONTAL

FIGURE 7-1. HI CAP VAS TEST POSITIONS

Table 7-2. Hi Cap VM Cooler Test Matrix

Test No	Rider Ring Material	Cylinder or Coating Material
1	6-84-1	Ion-plated alumina
2	6-84-1	Ion-plated alumina
3	6-84-1	Ion-plated alumina
4	PM-107	Ion-plated alumina

7.3 Dynamic test module - The accelerated wear rate tests of the critical spaceborne cooler components shall be conducted in test increments of 2500 hours each with a goal of achieving 30,000 "equivalent" hours. With the candidate hot rider rings and hot cylinder liners installed per Table 7-3, the following steps shall be repeated during each incremental test period:

- Step 1 - Fill out data sheets on measurements and observations of wear rate parts and components. Place sheets in log book.
- Step 2 - With the unit installed as specified, pretest performance parameters shall be obtained and recorded on the data sheet.
- Step 3 - The unit shall be continuously operated for 2,500 hours with test data collected automatically at regular intervals.
- Step 4 - At the end of the test period, a post-test performance test shall be made and recorded on the data sheet in the log book.

Step 5 - The dynamic test module shall be disassembled as required for examinations to measure component wear rates and to analyze contamination debris for material content.

Step 6 - The unit shall be prepared as necessary for its next test.

Table 7.3 Test Module Test Matrix

Test No.	Rider Ring Material		Cylinder or Coating Material
	Cylinder 1	Cylinder 2	
1	PM 107	6-84-1	Ion-plated alumina
2	PM-107	6-84-1	Ion-plated alumina
3	PM 107	6-84-1	Ion-plated alumina
4	PM 107	6-84-1	Ion-plated alumina

## 8 DATA

8.1 Test data acquisition - Adequate test data shall be recorded and summarized in test reports to document the performance of the test units before and after each incremental test period. During the specified test period, instrumentation outputs of the test units will be automatically scanned every hour on paper tape as an analog output voltage. These data can be processed later on as desired, as a printed readout in scientific units or stored for future recall on magnetic tape. In the event of a failure mode, the acquisition system shall scan and record output data before shutdown of the unit. Printed teletype data shall be reviewed daily or as necessary to capture any trends that may indicate impending failure or component degradation.

8.2 Components evaluation - Separate components inspection sheets shall be made to record physical and mechanical measurements before and after testing as necessary for each type of critical component to be evaluated. The inspection sheet shall include, as required, material, serial number, physical dimensions, weight, test number and hours, and other pertinent measurements listed in Section 6 and in the attached data sheets.

8.3 Wear Projection - Each time any of the test units are disassembled, a projection of the total wear life of each wear component shall be made using the equation:

$$V = K \frac{N}{R} \text{ or } VT \text{ Where:}$$

$$R = P$$

V = wear volume

T = sliding duration

R = radial wear

K = wear constant

V = average velocity

N = normal load

P = unit load  $\left( \frac{N}{\text{wear area}} \right)$

9. SCHEDULE

9.1 Test Schedule - The planned test schedule for the three types of test units is shown in Figure 9-1. The schedule may be subject to change because of unexpected failures of the test units, critical components or essential supporting equipment. In any event, such changes or deviations to the schedule shall be made with concurrence by the AFFDL.

FIGURE 9-1. TEST SCHEDULE

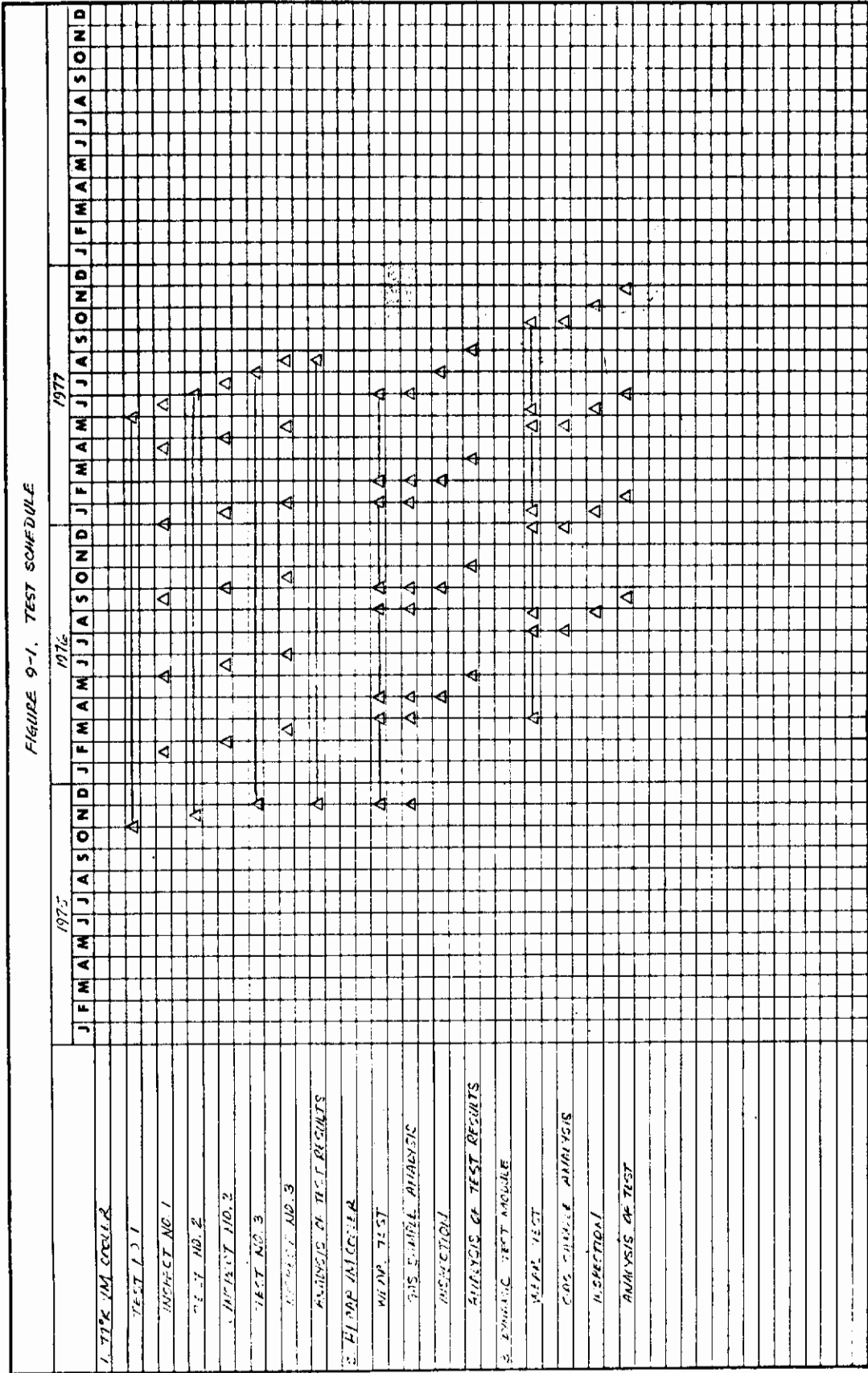

NSA Form 31-0 (Rev. 6-55)

10. SAFETY

10.1 Safety factors - Provisions for safety shall be in accordance with MIL-STD-454, Requirement 1.

11. QUALITY

11.1 Quality Requirements - Quality requirements are per PQR E012 attached.

11.2 Documentation - All data sheets including performance data, component measurements and wear measurements shall be incorporated in the log book assigned to each machine. Copies of all Quality History Records (QHR) will be made part of the log book.

11.3 Traceability - Vendor procured components shall be material certified by the manufacturer. All components shall be inspected to physical dimensions called out on the HAC Drawing. In the case of hot rider rings the material shall be certified by the vendor and quality control records shall be reviewed by a HAC source inspector before shipment. All rings shall be individually packaged and the material shall be noted on the outside of the package, after receipt at HAC each unopened package shall be delivered to the REA for ring segment marking. After marking, each ring shall be returned to its package and sent to the primary standards laboratory for inspection per the data sheet. After inspection each ring shall be returned to its package and the package with accompanying data sheets shall be returned to the REA for storage and final disposition.



**HUGHES**

**EL SEGUNDO MANUFACTURING DIVISION  
QUALITY ASSURANCE DEPARTMENT**

## PROGRAM QUALITY REQUIREMENTS

POR NO.	E012
DATE:	8-6-75
PAGE:	1 of 4

**PROGRAM NAME:** VM Cooler Wear Rate Testing

**CONTRACT NO. REFERENCE:** F33615-75-C-3117  
D4939

**CONTRACT QUALITY SPEC:** 7-402.5 (a)(1)  
**CUSTOMER REP.:** Aeronautical Systems Div. (USAF)

(A) Quality Level ADV/STD : Test Module & Associated Piece Parts (CLIN 0001 AA) (Note I)

(B) Quality Level ADV/STD : VM Cooler Replacement Parts (CLIN 0001 AB) (Note II)

(C) Quality Level ADV/HAC : Special Test Equipment (STE)(CLIN:0001 AB)(Note III)

(D) Quality Level EXP/HAC : Non-Deliverable Hardware (Note 1)

(E) Quality Level \_\_\_\_\_

(F) Quality Level \_\_\_\_\_

ELEMENT	SUB ELEMENT	REQUIREMENT	QUALITY LEVEL					
			A	B	C	D	E	F
<b>DRAWINGS</b>	SKETCH	QP 2.1	X	-	X			
	REA RELEASE	QP 2.1	-	X	-			
	EDC RELEASE	QP 2.1	-	-	-			
	CUSTOMER CONTROLLED		-	-	-			
<b>DRAWING CHANGES</b>	MARKED PRINT-ENGR. SIGN OFF	QP 2.1	X	2	X			
	DCN	QP 2.1	-	2	-			
	E.O.	QP 2.1	-	2	-			
	CUSTOMER CONTROLLED		-	-	-			
<b>CONFIGURATION MANAGEMENT</b>	DRS CONFIG. VERIFICATION	QP 2.1.100	-	-	-			
	CVI CONFIG. VERIFICATION	QP 2.1.101	-	-	-			
	FIRST ARTICLE VERIFICATION	QP 1.2.101	-	-	-			
	PRODUCT REVIEW	QP 1.2.101	-	-	-			
	DEVIATIONS AND WAIVERS	QP 2.1.103	-	-	-			
<b>PROCUREMENT</b>	PROCUREMENT DOC. SCREENING	QP 3.2.100	3	3	3			
	AUTHORIZED PARTS LIST		4	4	4			
	INCOMING INSPECTION AND TEST	QP 4.1.100	X	X	X			
	TVI INSPECTION	QP 4.3.103	-	-	-			
<b>SPECIAL PROCESSES</b>	CERT. OF PROCESSES & EQUIPMT.	QP 4.2	X	X	-			
	CERTIFICATION OF PERSONNEL	QP 4.2	X	X	-			
	ENVIRONMENTAL CONTROLS	HP 10-22	-	-	-			
	ASSEMBLY CONDITIONING		-	-	-			
<b>NON-CONFORMING SUPPLIES</b> MRR NO. 112	ENGINEERING DISPOSITION (ED)	QP 4.5	X	5	5			
	ENGINEERING REVIEW (ER)	QP 4.5	-	-	-			
	MATERIAL REVIEW BOARD (MRB)	QP 4.5	-	-	-			
	QCP	QP 5.2	-	5	5			

**HUGHES**

EL SEGUNDO MANUFACTURING DIVISION  
QUALITY ASSURANCE DEPARTMENT

## PROGRAM QUALITY REQUIREMENTS

PQR NO. E012
DATE: 8-5-75
PAGE: 2 of 4

ELEMENT	SUB ELEMENT	REQUIREMENT	QUALITY LEVEL					
			A	B	C	D	E	F
IN PROCESS CONTROLS	PLANNING SCREENING	QP 1.3.101	-	-	-			
	FABRICATION INSPECTION	QP 4.2	6	6	6			
	WORKMANSHIP FABRICATION	AFC SHOP STANDARDS	X	X	X			
	ASSEMBLY INSPECTION	QP 4.2	6	6	6			
	WORKMANSHIP ASSEMBLY	For Eng. Drawing	X	X	X			
	TEST EQUIPMENT SEALING	QP 2.2	-	-	-			
	TVI INSPECTION	QP 4.3.103	-	-	-			
	MANDATORY CUST. INSP. (MCI)	QP 5.3	-	-	-			
FINAL ACCEPTANCE	COMPLETED ITEM INSP. & TEST	QP 4.3.101	-	-	-			
	FINAL ITEM VERIFICATION	QP 4.3.100	-	-	-			
	TVI INSPECTION	QP 4.3.103	-	-	-			
	PACKAGING & SHIPPING INSP.	QP 4.4.103	5.2	5.2	5.2			
	DD FORM 250 APPROVAL	QP 4.4.103	X	X	X			
	CUST. REQUIRED DATA REPORTS	QP 4.8.100	-	-	-			

### RELIABILITY AND QUALITY TEST REQUIREMENT

RELIAB. SPEC:

REQUIREMENT	ELEMENT	A	B	C	D	E	F
DOCUMENTS	TIME & CYCLE LOG	-	-	-			
	TEST DATA RETENTION	-	-	-			
	CONTROL ITEM LOG BOOK	7	7	-			
TESTS	SUBASSEMBLY	-	-	-			
	CONTROL ITEM	-	-	-			
	SUBSYSTEM	-	-	-			
	QUALIFICATION	-	-	-			
	RELIABILITY	-	-	-			
FAILURE REPORTING	TFR (QP 9.121)	-	-	-			
	COMPONENT REJECTION PROCEDURE (QP 1.4.103)	-	-	-			

D - DATA REVIEW; S - SURVEILLANCE; V - VERIFICATION; T - QUALITY ASSURANCE TEST

**GENERAL:**

- I. A special dynamic test module will be designed, fabricated and tested to obtain wear rate data of the selected life limiting components.
  
- II. The Government will furnish five VM Refrigerators to be used for component selection and initial wear rate tests. The following is Government Furnished Property (GFP):
  - VM Refrigerator P/N X3213200-110 S/N 2
  - VM Refrigerator P/N X3243002-100 S/N 1, 2 & 3
  - Ri-Cap VM Refrigerator P/N X3273700-100 S/N 2

HUGHES

EL SEGUNDO MANUFACTURING DIVISION  
QUALITY ASSURANCE DEPARTMENT

## PROGRAM QUALITY REQUIREMENTS

PQR NO.	E012
DATE:	8-6-75
PAGE:	3 of 4

GENERAL: (continued)

Also furnished is the support equipment for the Hi-Cap VM Refrigerator. Refurbishment of the GFP shall be as required to conduct the tests.

- III. JTE will be designed and fabricated/modified to operate and monitor the VM Refrigerators during testing.

NOTES:

1. Use PQR 16, Quality Level EXP/HAC, for non-deliverable hardware. Engineering Disposition (ED) in accordance with Exhibit B of Company QP 4.5 and MRR 112 are authorized for use on this hardware.
2. Drawing changes used for procurement must be DCNs and EOs. Marked prints may be used for inspection of equipment modifications.
3. Procurement
  - 3.1 Fabricated parts and assemblies will be inspection coded "51" with Q-1 attachment.
  - 3.2 Shelf Life Material and Calibratable Test Equipment will be inspection coded per QP 3.2.100.
  - 3.3 All other material will be inspection coded "51" for identity and damage.
4. Commercial parts may be used on this program.
5. GFP will be received per QP 5.2 and all discrepancies will be entered on the Quality History Record.
  - 5.1 After GFP is received, Engineering Disposition (ED) per Exhibit B of QP 4.5 will be applicable for nonconformance of new replacement items, refurbishment items and materials used for modification. ED will also be used to disposition nonconformance discovered in hardware that is repaired as required to maintain testing. All dispositions will be entered on the Quality History Record (QHR).
  - 5.2 GFP hardware will be returned to the customer using the appropriate DD form 175X.
6. In-process and Completed Item inspections will be performed as requested by the Responsible Engineering Activity (REA). All inspections will be documented on the Quality History Record (QHR) which will be part of the Control Item Log Book.
7. The Control Item Log Book will be the responsibility of the REA. Copies of all Quality History Records will be made part of the log book.

HUGHES

EL SEGUNDO MANUFACTURING DIVISION  
QUALITY ASSURANCE DEPARTMENT

PROGRAM QUALITY REQUIREMENTS

PQR NO.	E012
DATE:	8-6-75
PAGE:	4 of 4

*T. L. Campbell*

T. L. Campbell  
Quality Assurance Engineer  
Quality Assurance (26-83)  
Culver City

7-29-75

Date

*P. Tannous Jr*

P. Tannous, Jr, Manager  
Electro-Optical & Data Systems  
Quality Assurance  
Manufacturing Division

7/30/75

Date

*J. F. Skinner*

J. F. Skinner, Program Manager  
VM Cooler Wear Rate Testing  
72-20

7/29/75

Date

HI CAP RING SEGMENT INSPECTION SHEET (SEGMENT NO. \_\_\_\_\_)

TEST NO. \_\_\_\_\_ ( \_\_\_\_\_ HRS) DATE OF MEASUREMENTS: \_\_\_\_\_  
 MATERIAL \_\_\_\_\_ "BEFORE" \_\_\_\_\_  
 COOLER S/N \_\_\_\_\_ "AFTER" \_\_\_\_\_  
 (CODE = \_\_\_\_\_)

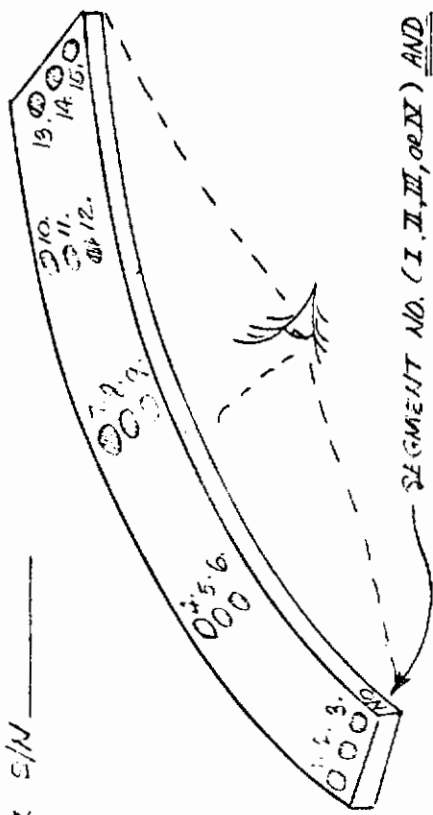

	01	02	03	04	05	06	07	08	09	10	11	12	13	14	15
BEFORE (IN.)															
AFTER (IN.)															
BEFORE (IN.)															
AFTER (IN.)															
BEFORE (IN.)															
AFTER (IN.)															

WEIGHT (BEFORE, G) \_\_\_\_\_  
 WEIGHT (AFTER, G) \_\_\_\_\_  
 HARDNESS \_\_\_\_\_  
 DENSITY \_\_\_\_\_

77 K PING SEGMENT INSPECTION SHEET (SEGMENT NO. \_\_\_\_\_)

TEST NO. \_\_\_\_\_ ( \_\_\_\_\_ HRS )      DATE OF MEASUREMENTS: \_\_\_\_\_  
 MATERIAL \_\_\_\_\_ ("BEFORE" \_\_\_\_\_)  
 COOLER S/N \_\_\_\_\_ ("AFTER" \_\_\_\_\_)

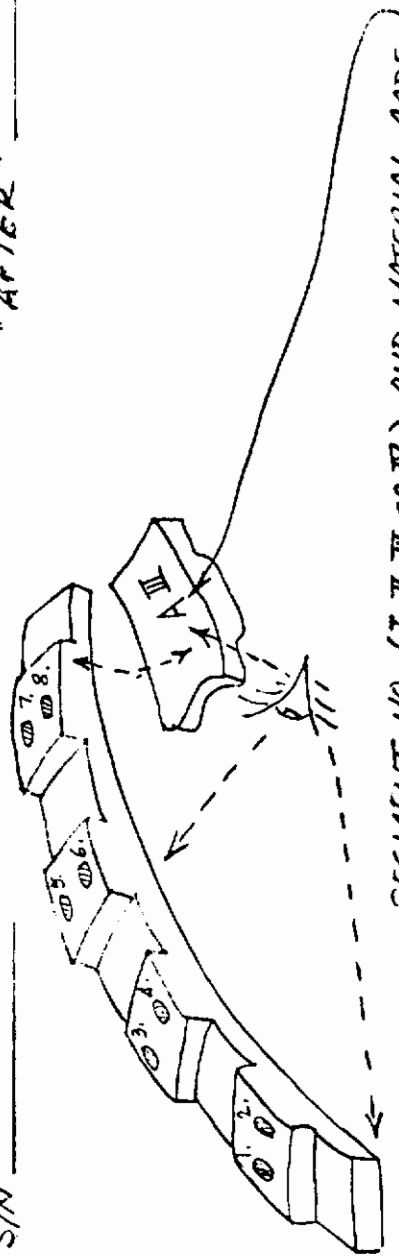

SEGMENT NO. (I, II, III or IV) AND MATERIAL CODE

①	③	⑤	⑦
BEFORE (IN.)	BEFORE (IN.)	BEFORE (IN.)	BEFORE (IN.)
AFTER (IN.)	AFTER (IN.)	AFTER (IN.)	AFTER (IN.)
②	④	⑥	⑧
BEFORE (IN.)	BEFORE (IN.)	BEFORE (IN.)	BEFORE (IN.)
AFTER (IN.)	AFTER (IN.)	AFTER (IN.)	AFTER (IN.)

WEIGHT (BEFORE, G) \_\_\_\_\_  
 WEIGHT (AFTER, G) \_\_\_\_\_  
 HARDNESS \_\_\_\_\_  
 DENSITY \_\_\_\_\_

HOT CYLINDER INSPECTION SHEET

HAC P/N \_\_\_\_\_ TEST NO. \_\_\_\_\_ ( \_\_\_\_\_ HRS )  
 LINER TREATMENT \_\_\_\_\_ COOLER S/N \_\_\_\_\_

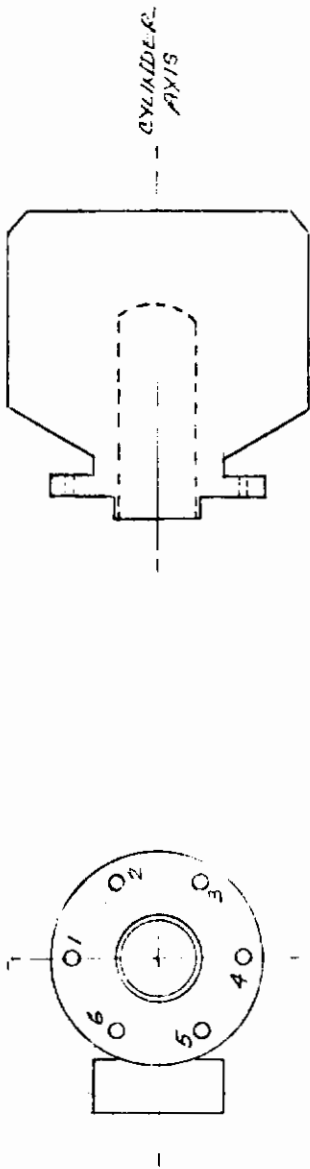

VERIFICATION OF STYLUS TRACE PROFILES OF ID OPPOSITE MOUNTING HOLES

LOCATION	BEFORE	AFTER
1		
2		
3		
4		
5		
6		
DATE		



RIDER RING INSPECTION SHEET

HAC P/N \_\_\_\_\_ TEST NO. \_\_\_\_\_ ( \_\_\_\_\_ HWS )  
 MATERIAL \_\_\_\_\_ COOLER S/N \_\_\_\_\_  
 ASSY USED ON \_\_\_\_\_

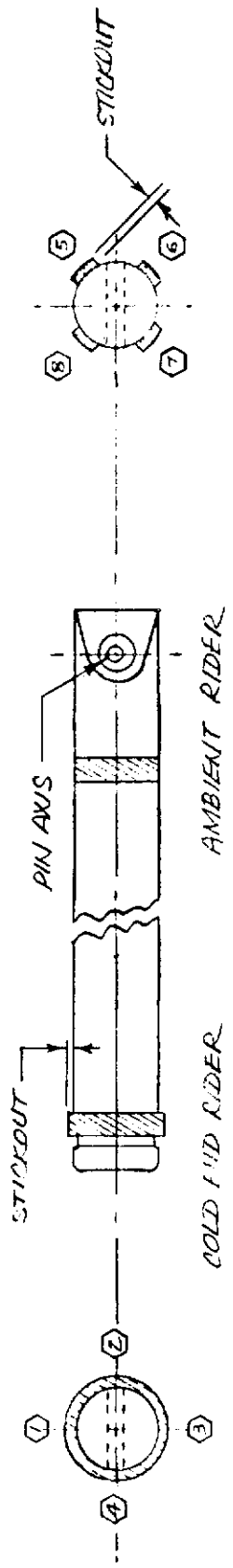

STICKOUT	BEFORE	AFTER
①		
②		
③		
④		
DATE		
EY		

STICKOUT	BEFORE	AFTER
⑤		
⑥		
⑦		
⑧		
DATE		
EY		

HEATER INSPECTION SHEET

HAC P/N \_\_\_\_\_ TEST NO \_\_\_\_\_ ( \_\_\_\_\_ M.S.)  
 ASSY USED ON \_\_\_\_\_ COOLER S/N \_\_\_\_\_  
 X-RAY VERIFICATION: DATE \_\_\_\_\_  
 BY \_\_\_\_\_

RESISTANCE	BEFORE	AFTER
DATE		
BY		

HOT TEMPERATURE SENSOR INSPECTION SHEET

HAC P/N \_\_\_\_\_ TEST NO. \_\_\_\_\_ ( \_\_\_\_\_ HRS )  
 VENDOR P/N \_\_\_\_\_ COOLER S/N \_\_\_\_\_  
 CALIBRATION VERIFICATION: \_\_\_\_\_  
 DATE \_\_\_\_\_  
 BY \_\_\_\_\_

	BEFORE		AFTER	
	SENS #1	SENS #2	SENS #1	SENS #2
EMF @ CONTROL TEMP				
DATE				
BY				

AMBIENT SEAL INSPECTION SHEET

HAC PIN \_\_\_\_\_ TEST NO \_\_\_\_\_ ( \_\_\_\_\_ HRS )  
 VENDOR PIN \_\_\_\_\_ COOLER S/N \_\_\_\_\_  
 MATERIAL \_\_\_\_\_ ASSY USED ON \_\_\_\_\_  
 SPRING WIRE DIA \_\_\_\_\_

	BEFORE	AFTER
WEIGHT		
LEAKAGE		
DATE		
BY		

COLD END SEAL INSPECTION SHEET

HAC P/N \_\_\_\_\_ TEST NO \_\_\_\_\_ ( \_\_\_\_\_ HRS )  
 Vendor P/N \_\_\_\_\_ COOLER S/N \_\_\_\_\_  
 MATERIAL \_\_\_\_\_ ASSY USED ON \_\_\_\_\_  
 SPRING WIRE DIA. \_\_\_\_\_

	BEFORE	AFTER
WEIGHT		
LEAKAGE		
DATE		
P.Y		

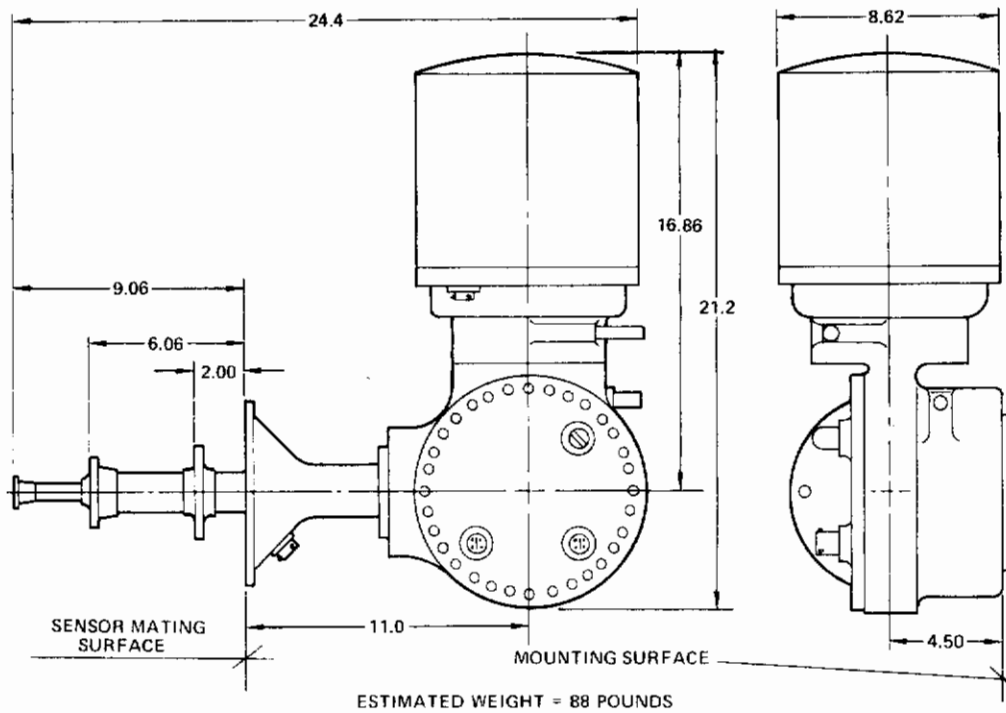

BEARING INSPECTION SHEET

HAC P/N \_\_\_\_\_ TEST NO \_\_\_\_\_ ( \_\_\_\_\_ HRS )  
 VENDOR P/N \_\_\_\_\_ COOLER S/N \_\_\_\_\_  
 VENDOR NAME \_\_\_\_\_ ASSY USED ON \_\_\_\_\_  
 PRELOAD \_\_\_\_\_  
 SEPARATOR MATERIAL \_\_\_\_\_

	BEFORE	AFTER
RADIAL PLAY		
MEASURING LOAD		
AVG RUNNING TORQUE		
MEASURING LOAD		
DATE		
BY		



SPECTROGRAPHIC ANALYSIS OF GAS SAMPLES

TEST NO. \_\_\_\_\_ ( \_\_\_\_\_ HRS )  
COOLER S/N \_\_\_\_\_

ELEMENT	MOLE, PER CENT	
	BEFORE	AFTER
HYDROGEN		
METHANE		
WATER		
NITROGEN / CARBON MONOXIDE		
OXYGEN		
ARGON		
HYDROCARBONS		
CARBON DIOXIDE		
TRIFLUOROMETHANE		
HELIUM		
DATE		
BY		

## REFERENCES

1. Jones, J. R. , "Hot Cycle Piston Ring Test Program," Hughes Aircraft Company document 2711.38/249 (8 September 1971).
2. Gardos, M. N. , "Long Wear Life VM Refrigerators," Hughes Aircraft Company document 2717.11/406 (15 June 1972).
3. Gardos, M. N. , "Topographical and Chemical Characterization of AmCerMet 701-65N Hot Rider Surfaces," Hughes Aircraft Company document 2717.21/259 (10 April 1973).
4. Gardos, M. N. , "Some Topographical and Tribological Characteristics of a  $\text{CaF}_2/\text{BaF}_2$  Eutectic-Containing Porous Nichrome Alloy Self-Lubricating Composite," ASLE Trans. , 18, 175 (1975).
5. Van Wyk, J. , "Friction and Wear Tests in Helium at 1200<sup>o</sup>F," Boeing Research Summary Report RSR-5542-0-16 (Hughes Contract F04701-70-C-0064) (30 July 1971).
6. Sliney, H. E. , "Self-Lubricating Composites of Porous Nickel and Nickel-Chromium Alloy Impregnated with Barium Fluoride-Calcium Fluoride Eutectic," ASLE Trans. , 9, 336 (1966).
7. Sliney, H. E. and Johnson, R. L. , "Preliminary Evaluation of Greases to 600<sup>o</sup>F and Solid Lubricants to 1500<sup>o</sup>F in Ball Bearings," ASLE Trans. , 11, 330 (1968).
8. "Fluoride-Metal Composite Material," Tech. Concentrates, Chem. Eng. News, 51, 10, August 27 (1973).
9. "News from NASA; NASA License Granted for Metal Lubricating Composite," Lub. Eng. , 29, 423 (1973).
10. Taber, R. D. et al. , "Seal Ring Design for Extreme Operating Conditions," paper presented at 30th ASLE Annual Meeting in Atlanta, Georgia, May 5-8 (1975), ASLE Preprint No. 75 AM-6D-2.
11. Anon. , "Surveyor III Parts and Materials/Evaluation of Lunar Effects—Returned from the Moon by Apollo XII," Hughes Aircraft Company document (22 January 1971).
12. Gardos, M. N. , "Hardness versus Wear of DC Motor Brush Material per HMS 20-1834; HS-331," Hughes Aircraft Company document 2717.32/04 (19 November 1973).
13. Manoogian, H. M. , "OSO DBA Dry Lubricated Brush D.C. Torque Motor and Bearing Life Test," Hughes Aircraft Company document 4113.20/1218 (HS 331/4883) (16 May 1974).

14. Mecklenburg, K. R., "Performance of Lubricant Compact Materials in Ball Bearings," AFML-TR-74-181 (September 1974).
15. Boes, D. J., "Unique Solid Lubricating Materials for High Temperature-Air Applications," ASLE Trans., 10, 19 (1967).
16. Boes, D. J. and Chamberlain, B., "Chemical Interactions Involved in the Formation of Oxidation-Resistant Solid Lubricant Composites," ASLE Trans. 11, 131 (1968).
17. Boes, D. J., et al., "The Solid Lubrication of Ball Bearings under High Speed - High Load Conditions from -225 to +1000<sup>o</sup>F," Lub. Eng., 27, 150 (1971).
18. Jones, J. R. and Gardos, M. N., "Friction and Wear Characteristics of Lubricative Composites in Air and in Vacuum," Lub. Eng., 27, 47 (1971).
19. Martin, P., Jr. and Murphy, G. P., "High Speed Oscillating Tests of Lubricating Composites," Lub. Eng., 29, 484 (1973).
20. White, G. W., "RF-Sputtering - Atomic Bullets Shoot Down Aircraft Maintenance Costs," paper presented at the 8th Annual FAA Int. Avia. Maint. Symp. (28 November 1972).
21. White, G. W., "Applications of Ion Plating," paper presented at the SAE Automobile Engineering Meeting, Detroit, Michigan (14-18 May 1973), Reprint 730546.
22. White, G. W., "New Applications of Ion Plating," Res. & Dev., 24, No. 7, 3 (1973).
23. Hale, G. J., White, G. W., and Meyer, D. E., "Ion Plating Using a Pure Ion Source: An Answer Looking for Problems," Electr. Packaging and Prod., 15, No. 5, 39 (1975).
24. Gardos, M. N., "Quality Control of Sputtered MoS<sub>2</sub> Films," paper presented at the 30th ASLE Annual Meeting, May 5-8, 1975, Atlanta, Georgia, ASLE Reprint 75AM-2D-2.
25. Greene, J. E., et al., "A Technique for Detecting Critical Loads in the Scratch Test for Thin Film Adhesion," Rev. Sci, Instrum., 45, 747 (1974).
26. Kharitonova, D. I., "Application and Friction Properties of Teflons at Low Temperatures," Wright-Patterson AFB Foreign Technology Div. Translation, FTD-MT-24-113-69 (April 1969).

# Contrails

27. Scibbe, H. W., "Bearings and Seals for Cryogenic Fluids," paper presented at SAE Fuels and Lubricants Meeting, Cleveland, Ohio, (13 November 1967).
28. Wisander, D. W. and Johnson, R. L., "Friction and Wear of Nine Selected Polymers with Various Fillers in Liquid Hydrogen," NASA TN D-5073 (March 1969).
29. Coe, H. H., et al., "Cooling Requirements of Ball Bearings Lubricated by Glass Fiber-Filled Polytetrafluoroethylene Retainers in Cold Hydrogen Gas," NASA TN D-5607 (February 1970).
30. Taber, R. D., et al., "Seal Rings Design for Extreme Operating Conditions," paper presented at 30th ASLE Annual Meeting in Atlanta, Georgia (5-8 May 1975) ASLE Reprint 75 AM-6D-2.
31. Archard, J. F. and Hirst, W., "The Wear of Metals Under Unlubricated Conditions," Proceedings of Royal Society, London, England (April 1956).
32. "Rulon and Teflon - High Performance Materials Through Formulation and Fabrication," Dixon Corporation Technical Bulletin, Bristol, Rhode Island.
33. O'Rourke, J. T., "You Can Tailor the Properties of 'Teflon' with Fillers," J. of Teflon (duPont) (September-October 1962).
34. Titus, J. B., "Effect of Low Temperature ( $0^{\circ}$  to  $-65^{\circ}$ F) on the Properties of Plastics," PLASTEC Report 30, Plastics Technical Evaluation Center, Picatinny Arsenal, Dover, New Jersey (July 1967).
35. Griffith, Q. A., Phil. Trans. Roy. Soc., A221 163 (1921).
36. Ferry, John D., Viscoelastic Properties of Polymers, John Wiley & Sons, Inc., New York (1970) p. 43.
37. Zapp, R. L., Rubber World, 133, 59 (1955).
38. Grosch, K. A., Proc. Roy. Soc., A274, 21 (1963).
39. Bartenev, G. M. and A. I. Elkin, J. Polymer Sci., Part C, 16, 1673 - 1693 (1967).
40. Ludema, K. C., and D. Tabor, Wear 9, 329 (1966).
41. Ferry, John D., "Viscoelastic Properties of Polymers," John Wiley & Sons, Inc., New York, 1970.
42. Boltzmann, L. Pogg, Ann. Physik, 1, 624 (1876).

# Contrails

43. Smith, T.L., and J.E. Frederick, *Journal of Applied Physics*, 36, p. 2996 (1965).
44. Ferry, John D., "Viscoelastic Properties of Polymers," John Wiley & Sons, New York (1970) p. 613.
45. "Computer Program for High Capacity Spacecraft Vuilleumier Refrigerator," Hughes Aircraft Company document 27740/120, prepared for Wright-Patterson Air Force Base, Ohio, (December 1972).
46. Ham, Crane, and Rodgers, Mechanics of Machinery, McGraw-Hill (1958).
47. Kelchner, R.E., "An Evaluation of Wear of Maverick Refrigerator Seal Materials", Hughes Aircraft Company document 7052.12/376 (October 1975).
48. Skinner, J.F., "Eight Technical Progress Report on Wear Rate Program". Hughes Aircraft Company document 7220.1/75.

# *Contrails*