

AIRCRAFT GROUND-FLOTATION INVESTIGATION
PART XII — DATA REPORT ON TEST SECTION 12

W. BRABSTON and G. HAMMITT II

*** Export controls have been removed ***

This document is subject to special export controls and each transmittal to foreign governments or foreign nationals may be made only with prior approval of the Air Force Flight Dynamics Laboratory (FDFM), Wright-Patterson AFB, Ohio 45433.

FOREWORD

The investigation described herein constitutes one phase of studies conducted during 1964 and 1965 at the U. S. Army Engineer Waterways Experiment Station (WES) under U. S. Air Force Project No. 410-A, MIPR No. AS-4-177, "Development of Landing Gear Design Criteria for the CX-HLS Aircraft." (The CX-HLS is now designated C-5A.) This program was sponsored and directed by the Landing Gear Group, Air Force Flight Dynamics Laboratory, Research and Technology Division, Mr. R. J. Parker, Project Engineer.

These tests were conducted by personnel of the WES Flexible Pavement Branch, Soils Division, under the general supervision of Messrs. W. J. Turnbull, A. A. Maxwell, and R. G. Ahlvin and the direct supervision of Mr. D. N. Brown. Other personnel actively engaged in this study were Messrs. C. D. Burns, D. M. Ladd, W. N. Brabston, H. H. Ulery, Jr., A. J. Smith, Jr., W. J. Hill, Jr., and G. M. Hammitt II. This report was prepared by Messrs. Brabston and Hammitt.

Directors of WES during the conduct of this investigation and preparation of this report were Col. Alex G. Sutton, Jr., CE, and Col. John R. Oswalt, Jr., CE. Technical Director was Mr. J. B. Tiffany.

Publication of this technical documentary report does not constitute Air Force approval of the report's findings or conclusions. It is published only for the exchange and stimulation of ideas.

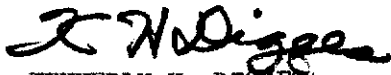

KENNERLY H. DIGGES
Chief, Mechanical Branch
Vehicle Equipment Division
AF Flight Dynamics Laboratory

ABSTRACT

This data report describes work undertaken as part of an overall program to develop ground-flotation criteria for the C-5A aircraft. A test section was constructed to a width adequate for two test lanes. Each lane was divided into three items having different subgrade CBR values and different traffic surfaces. Item 1 was surfaced with modified T11 aluminum landing mat, item 2 with M8 steel landing mat, and item 3 remained unsurfaced. Traffic was applied to the lanes using a 105,000-lb test load on a three-wheel-abreast assembly consisting of three 56x16, 24-ply aircraft tires with inflation pressure of 100 psi. Wheel spacing was 33 in. c-c for one lane and 27 in. c-c for the other lane.

The information reported herein includes layout of the test lanes, characteristics and print dimensions of the load assembly tires, and data collected on soil strengths, surface deformations and deflections, and draw-bar pull. The traffic-coverage level is given at which each test item was considered failed.

Contrails

CONTENTS

	<u>Page</u>
SECTION I: INTRODUCTION	1
SECTION II: DESCRIPTION OF TEST SECTION AND LOAD VEHICLE	2
Description of Test Section	2
Load Vehicle.	2
SECTION III: APPLICATION OF TRAFFIC, FAILURE CRITERIA, AND DATA COLLECTED	3
Application of Traffic.	3
Failure Criteria and Data Collected	3
SECTION IV: BEHAVIOR OF ITEMS UNDER TRAFFIC AND TEST RESULTS	6
Lane 26	6
Lane 27	8
SECTION V: PRINCIPAL FINDINGS	11

Contracts

ILLUSTRATIONS AND TABLES

<u>Figure</u>	<u>Page</u>
1. Traffic distribution patterns, Test Section 12	3
2. Test load vehicle	15
3. Lane 26, item 1, prior to traffic	15
4. Lane 26, item 1. Transverse straightedge shows roughness at 150 coverages (failure)	16
5. Lane 26, item 2, prior to traffic	16
6. Lane 26, item 2. Transverse straightedge shows roughness at 150 coverages (failure)	17
7. Lane 26, item 3, prior to traffic	17
8. Lane 26, item 3. Transverse straightedge shows roughness at 72 coverages (failure)	18
9. Lane 27, item 1, prior to traffic	18
10. Lane 27, item 1. Transverse straightedge shows roughness at 68 coverages (failure)	19
11. Lane 27, item 2, prior to traffic	19
12. Lane 27, item 2. Transverse straightedge shows roughness at 68 coverages (failure)	20
13. Lane 27, item 3, prior to traffic	20
14. Lane 27, item 3. Transverse straightedge shows roughness at 30 coverages (failure)	21
15. Layout of Test Section 12 and summary of test results	22
16. Layout of surfaced items	23
17. Tire-print dimensions and tire characteristics	24
18. Average cross-sectional deformations	25
19. Permanent profile deformations	26
20. Average deflections, lane 26	27
21. Average deflections, lane 27	28

<u>Table</u>	<u>Page</u>
1. Summary of Traffic Data, Test Section 12	13
2. Summary of CBR, Density, and Water Content Data, Test Section 12	14

SUMMARY

Tests on Section 12 are one phase of a comprehensive research program to develop ground-flotation criteria for heavy cargo-type aircraft. Section 12 consisted of two similar traffic lanes, lanes 26 and 27, each of which was divided into three items having different traffic surfaces and different subgrade CBR values (figure 15). Items 1 and 2 were surfaced with T11 aluminum and M8 steel landing mat, respectively (figure 16), and item 3 remained unsurfaced.

Traffic was applied to the two lanes using a 105,000-lb load on a three-wheel-abreast assembly consisting of three 56x16, 24-ply aircraft tires inflated to 100 psi. Wheel spacings were 33 and 27 in. c-c for lanes 26 and 27, respectively. Figure 17 gives pertinent tire-print dimensions and tire characteristics.

The lanes were trafficked to failure in accordance with the criteria designated in Part I of this report. Data were recorded throughout testing to give a behavior history of each item. Using the test criteria mentioned above, it was possible to directly compare the effects of trafficking with the three-wheel-abreast assembly using different wheel spacings. Basic performance data are summarized in the following paragraphs.

Lane 26

Item 1

The item was considered failed at 150 coverages due to roughness. The rated CBR of the item was 2.2.

Item 2

The item was considered failed at 150 coverages due to roughness. The rated CBR was 3.7.

Item 3

The item was considered failed at 72 coverages due to roughness. The rated CBR was 11.0.

Contrails

Lane 27

Item 1

The item was considered failed at 68 coverages due to roughness. The rated CBR was 2.4.

Item 2

The item was considered failed at 68 coverages due to roughness. The rated CBR of the item was 3.7.

Item 3

The item was considered failed at 30 coverages due to roughness. The rated CBR of the item was 10.0.

Contrails

AIRCRAFT GROUND-FLOTATION INVESTIGATION

PART XII DATA REPORT ON TEST SECTION 12

SECTION I: INTRODUCTION

The investigation reported herein is one phase of a comprehensive research program being conducted at the U. S. Army Engineer Waterways Experiment Station (WES), Vicksburg, Miss., as part of U. S. Air Force Project 410-A, MIPR No. AS-4-177, to develop ground-flotation criteria for the C-5A, a heavy cargo-type aircraft. Specifically, the tests reported herein were conducted to determine the trafficking effect of two tire spacings of three-wheel-abreast landing-gear assemblies on landing mat and unsurfaced soils under similar conditions of loading.

Prosecution of this investigation consisted of constructing two similar traffic lanes and subjecting them to equal test loads with a three-wheel-abreast landing-gear assembly using different wheel spacings for the two lanes. This report presents a description of the test section and wheel assemblies, and gives results of traffic. Equipment used, types of data and method of recording them, and general test criteria are summarized herein with more complete explanations and illustrations appearing in Part I of this report.

SECTION II: DESCRIPTION OF TEST SECTION AND LOAD VEHICLE

Description of Test Section

Test Section 12 (figure 15) was constructed within a roofed area in order to allow control of the subgrade CBR (California Bearing Ratio) in the test items. Section 12 was located on the same site as Test Sections 9, 6, 4, and 2 in this series. The original construction of the test site is described in Part III of this report. The underlying subgrade was undisturbed by prior tests on the site so that in construction of Section 12 only the upper 24 in. of soil was excavated. The excavated area was back-filled in four compacted lifts with a heavy clay soil (buckshot; classified as CH according to the Unified Soil Classification System, MIL-STD-619). The fill material used was a local clay with a plastic limit of 27, liquid limit of 58, and plasticity index of 31. Gradation and classification data for the subgrade material are given in Part I.

Two traffic lanes, each divided into three items, were constructed in the test section. Different subgrade strengths were obtained in the items (figure 15) by controlling the water content and compaction effort. Items 1 and 2 were surfaced with modified T11 aluminum and M8 steel landing mat, respectively (figure 16). Item 3 remained unsurfaced. The landing mat used is described and illustrated in Part I.

Load Vehicle

The load vehicle used in trafficking lanes in Section 12 is shown in figure 2. Load cart construction, details of linkage between the load compartment and prime mover, and method of applying load are explained in Part I. For trafficking lanes 26 and 27, the load compartment was weighted to produce a load of 105,000 lb on a three-wheel-abreast tracking assembly. For trafficking, the load wheels were spaced 33 and 27 in. c-c for lanes 26 and 27, respectively. Three 56x16, 24-ply aircraft tires with inflation pressure of 100 psi were used and the three wheels were on a single axle. Tire-print data and pertinent tire characteristics are given in figure 17.

SECTION III: APPLICATION OF TRAFFIC, FAILURE CRITERIA, AND DATA COLLECTED

Application of Traffic

Traffic was applied to the test lanes in a nonuniform pattern with intensity of traffic being varied within each lane to produce three zones of approximately 100, 80, and 20 percent traffic coverage. Traffic so distributed within a traffic lane simulates as nearly as possible the bell-shaped traffic distribution curve which results from the wander of aircraft from the lane center line. The coverage levels referred to in the tables and text of this part are the total number of coverages applied to the 100 percent coverage zone. The corresponding number of coverages applied to the outer traffic zones is proportional to the percentage factor for the respective zones, as shown in figure 1. In lane 26 the lane width was not an exact multiple of the tracking-tire widths and spacings so that it was necessary to determine a coverage factor to compensate for small gaps in the traffic pattern.

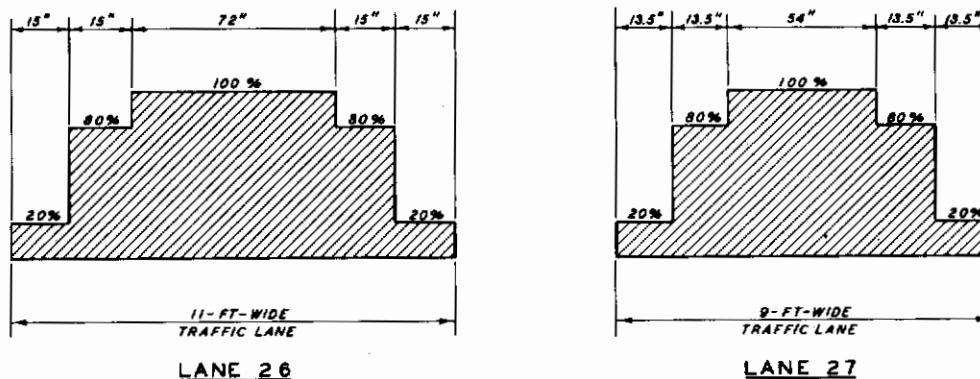

NOTE: PERCENTAGE FIGURES SHOW PERCENT
OF TOTAL COVERAGES.

Figure 1. Traffic distribution patterns, Test Section 12

Failure Criteria and Data Collected

Failure criteria used in this investigation and descriptive terms used in presentation and discussion of data in all reports in this series are presented in Part I. A general outline of types of data collected is given in the following paragraphs. Details on apparatus and procedure for obtaining specific measurements are given in Part I.

CBR, water content, and dry density

CBR, water content, and dry density of the subgrade were measured

Contrails

for each test item prior to application of traffic, at intermediate coverage levels, and at failure or suspension of traffic if no failure condition was reached. After traffic was concluded on an item, a measure of subgrade strength termed "rated CBR" was determined. Rated CBR is generally the average CBR value obtained from all the determinations made in the top 12 in. of soil during the test life of an item. In certain instances, extreme or irregular values may be ignored if the analyst decides that they are not properly representative.

Surface roughness, or differential deformation

Surface roughness, or differential deformation, measurements were made using a 10-ft straightedge at various traffic-coverage levels on all items. Rut depths were measured for unsurfaced items, and dishing effects of individual mat panels in the mat-surfaced items were recorded.

Deformations

Deformations, defined as permanent cumulative surface changes in cross section or profile of an item, were charted by means of level readings at pertinent traffic-coverage levels.

Deflection

Deflection of the test surface under an individual static load of the tracking assembly was measured at various traffic-coverage levels on both surfaced and unsurfaced items. Level readings on the item surface on each side of the load wheels and on a pin and cap device directly beneath a load wheel provided deflection data. Both total (for a single loading) and elastic (recoverable) deflections were measured on unsurfaced item in lane 26; only total deflection was measured in lane 27. All mat deflection was for practical purposes recoverable; i.e. total deflection equaled elastic (spring-back) deflection. The pin and cap device for measuring deflection directly beneath load wheels was applied to the subgrade of surfaced items through a hole (existing or cut) in the mat.

Rolling resistance

Rolling resistance, or drawbar pull, measurements were performed with the load vehicle over each test item at designated coverage levels. Three types of drawbar measurements were taken: (a) maximum force required to overcome static inertia and commence forward movement of the load cart, termed "initial DBP"; (b) average force required to maintain a constant speed once the load vehicle is in motion, termed "rolling DBP"; and (c) maximum force obtained during the constant speed run, termed "peak DBP."

Contrails

Mat breaks

Mat breaks on the surfaced items were inspected, classified by type, and recorded on the data sheet at various coverage levels.

SECTION IV: BEHAVIOR OF ITEMS UNDER TRAFFIC AND TEST RESULTS

Lane 26

Behavior of items under traffic

Item 1. Item 1 prior to traffic is shown in figure 3. After 20 coverages, mat deformations measured about 1 in. and there were no mat breaks. Traffic was continued to 150 coverages at which time item 1 was considered failed due to roughness (figure 4). The rated CBR of the item was 2.2.

Item 2. Item 2 prior to traffic is shown in figure 5. After 20 coverages, average mat deformation measured slightly less than 1 in. Traffic was continued to 150 coverages at which time item 2 was considered failed due to roughness. At failure, there was a considerable amount of subgrade extruded through the tubulated holes in the mat (figure 6). There were no mat breaks at failure. The rated CBR of the item was 3.7.

Item 3. Item 3 prior to traffic is shown in figure 7. After 20 coverages, there was moderate soil deformation with an average rut depth of 0.78 in. At 72 coverages, the item was considered failed due to roughness (figure 8). The rated subgrade CBR was 11.0.

Test results

Table 1 summarizes traffic data recorded on each item of lane 26 during testing. Soil test data are given in table 2. Table 1 contains drawbar pull values for the load vehicle operated over an asphalt-paved strip for comparison with drawbar pull recorded on the test items.

Item 1. Item 1 was considered failed due to roughness at 150 coverages. The following information was obtained from traffic tests on item 1.

- a. Roughness. At failure, the average transverse and diagonal differential deformations were 2.61 and 2.41 in., respectively (table 1). Average dishing of individual panels was 0.44 in. Table 1 also gives differential deformations and dishing measurements at several intermediate coverage levels.
- b. Deformation. Average cross-section deformations for two typical mat runs are shown in figure 18 for 72 and 150 coverages. No great change in deformations was evident between the two coverage levels. The profile deformation shown in figure 19 is very irregular at failure but deformation exceeds 2 in. at only one mat run.
- c. Deflection. Average elastic mat deflections are shown in figure 20

Contrails

for three positions of wheel assembly relative to panel end joints. Deflections were large at failure, exceeding 4 in. for two positions of the wheel assembly. Mat standoff, or bridging, of approximately 1.3 in. contributed to the unusually large mat deflections.

- d. Rolling resistance. Initial and rolling drawbar pull increased steadily with traffic to failure while peak drawbar pull reached a maximum at 72 coverages and decreased slightly at failure (table 1).
- e. Mat breaks. Mat breaks are shown by type in table 1. Many breaks consisting mainly of sheared rivets were evident at failure.

Item 2. Item 2 was considered failed due to roughness at 150 coverages. The following information was obtained from traffic tests on item 2.

- a. Roughness. Differential deformations increased steadily with traffic (table 1). Average transverse and diagonal differential deformations were 2.88 and 2.13, respectively, at failure. Dishing of individual panels averaged 0.25 in. at failure.
- b. Deformation. Average cross-section deformations for the two typical mat runs are shown in figure 18 for 72 and 150 coverages. Figure 19 shows profile deformations for the same coverage levels.
- c. Deflection. Average elastic mat deflections for the center line of assembly located at three positions relative to panel end joints are shown in figure 20. Results were rather erratic with no consistent pattern of deflection apparent.
- d. Rolling resistance. Initial, peak, and rolling drawbar pull increased with traffic (table 1). Greatest relative increase was in rolling resistance which measured 3.1 and 7.5 kips at 0 and 150 coverages, respectively.
- e. Mat breaks. No mat breaks were evident at failure of the item.

Item 3. Item 3 was considered failed due to roughness at 72 coverages. The following information was obtained from traffic tests on item 3.

- a. Roughness. Differential deformations and rut depths are shown in table 1 for 20 and 72 coverages. Transverse and diagonal differential deformations were most significant with average values of 3.53 and 3.69 in., respectively, at failure. Ruts were less severe, averaging 2.91 in. at failure.
- b. Deformation. The average cross-section deformation at failure is shown in figure 18. The center-line profile deformation in figure 19 indicates a much more severe condition of settlement with deformations reaching 3.5 in.

Contrails

- c. Deflection. Average total soil deflections at 0 and 72 coverages are shown in figure 20. Elastic subgrade deflection was 0.4 in. at failure, an increase from 0.2 in. prior to traffic (table 1).
- d. Rolling resistance. Initial and rolling drawbar pull showed increases with traffic while peak drawbar pull decreased slightly (table 1).

Lane 27

Behavior of items under traffic

Item 1. Item 1 prior to traffic is shown in figure 9. At 30 coverages, most of the center-line rivets in the panel in run 6 had sheared and the panel separated. At this time, mat runs 1-9 were eliminated from further consideration in testing. With continued traffic, additional panel center-line rivets failed and at 68 coverages the item was considered failed due to roughness and mat deterioration (figure 10). The rated CBR of the item was 2.4.

Item 2. Item 2 prior to traffic is shown in figure 11. With continued traffic there was a considerable amount of subgrade extruded through the tubular holes in the mat. At 68 coverages the item was considered failed due to roughness (figure 12). The rated CBR of the item was 3.7.

Item 3. Item 3 prior to traffic is shown in figure 13. The item deformed rather easily under traffic and at 30 coverages was considered failed due to roughness (figure 14). The rated CBR of the item was 10.

Test results

Results of trafficking lane 27 are summarized in table 1. Soil test data are given in table 2. Table 1 contains drawbar pull values for the load vehicle operated over an asphalt-paved strip for comparison with drawbar pull values recorded on the test items.

Item 1. Item 1 was considered failed at 68 coverages. The following information was obtained from traffic tests on item 1.

- a. Roughness. Table 1 shows the steady development of differential deformations and dishing with continued traffic. Average transverse, diagonal, and longitudinal differential deformations at failure were 3.41, 3.88, and 3.38 in., respectively. Average dishing of individual panels was 1.22 in.
- b. Deformation. Cross-section deformations at 20 and 68 coverages are shown in figure 18. Due to elimination of runs 1-9 from

Contrails

consideration, the cross-section plots do not represent averages but only single measurements at mat runs 13 and 16 as indicated. The elevated position of the mat surface at run 13 for 68 coverages was due to the extreme longitudinal deformations which resulted in transverse humps in the traffic lane. The very severe profile deformations that existed at failure are evident in figure 19.

- c. Deflection. Average elastic mat deflections for three positions of the wheel assembly relative to panel end joints are shown in figure 21. A principal component of elastic mat deflections was the standoff, or bridging, of mat above the subgrade caused by loss of mat embedment and subsequent subgrade settlement. Elastic mat deflections increased with trafficking. No deflections were obtained at failure with the wheel assembly centered on a panel quarter point because of extreme mat damage.
- d. Rolling resistance. Drawbar pull values at 0 and 68 coverages are shown in table 1. Initial drawbar pull was not measured at failure but peak and rolling drawbar values registered increases with traffic.
- e. Mat breaks. The mat breaks observed at various coverage levels are given by type in table 1. A large number of mat breaks existed at failure with the most common type being sheared rivets along the center-line splice joint of individual panels.

Item 2. Item 2 was considered failed at 68 coverages. The following information was obtained from traffic tests on item 2.

- a. Roughness. Table 1 shows differential deformations and dishing at 20 and 68 coverages. At failure, average transverse, diagonal, and longitudinal differential deformations were 3.66, 3.63, and 1.10 in., respectively. Dishing of individual mat panels at failure averaged 0.19 in.
- b. Deformation. Average cross-section deformations, shown in figure 18, increased considerably with traffic. The profile deformations at 20 and 68 coverages shown in figure 19 indicate a general settlement of the test item with trafficking.
- c. Deflection. Average elastic mat deflections for three positions of the wheel assembly relative to panel end joints are shown in figure 21. Elastic mat deflections increased fairly consistently with traffic.
- d. Rolling resistance. All drawbar pull values increased with traffic (table 1).
- e. Mat breaks. No mat breaks were in evidence at failure.

Item 3. Item 3 was considered failed at 30 coverages. The following

Contrails

information was obtained from traffic tests on item 3.

- a. Roughness. Differential deformations and rut depths are shown in table 1 for 20 and 30 coverages. Average transverse and diagonal differential deformations (4.63 and 4.75 in., respectively) exceeded the average rut depth (3.75 in.) at failure.
- b. Deformation. Average cross-section and profile deformations at 20 and 30 coverages are shown in figures 18 and 19, respectively. Both figures indicate progressive deterioration under traffic with figure 19 showing settlement along the length of the item.
- c. Deflection. Average total soil deflections under static load of the load wheel assembly are shown in figure 21 for several coverage levels. Deflections were somewhat erratic and did not increase greatly with trafficking.
- d. Rolling resistance. Drawbar pull values at 0 and 30 coverages, shown in table 1, increased with traffic. Rolling drawbar pull showed the largest relative increase (2.7 to 6.8 kips).

Contrails

SECTION V: PRINCIPAL FINDINGS

From the foregoing discussion, the principal findings relating test load, wheel assembly, tire inflation pressure, surface type, subgrade CBR, and traffic coverages are as follows:

<u>Load, Wheel Assembly, and Tire Pressure</u>	<u>Type of Surface</u>	<u>Rated Subgrade CBR</u>	<u>Coverages at Failure</u>
105,000-lb load; three-wheel- abreast assembly (33-in. c-c); 56x16, 24-ply tires at 100-psi inflation pressure	Modified T11 aluminum mat	2.2	150
	M8 steel mat	3.7	150
	Unsurfaced	11.0	72
105,000-lb load; three-wheel- abreast assembly (27-in. c-c); 56x16, 24-ply tires at 100-psi inflation pressure	Modified T11 aluminum mat	2.4	68
	M8 steel mat	3.7	68
	Unsurfaced	10.0	30

Contrails

TABLE I
SUMMARY OF TRAFFIC DATA, TEST SECTION 12

Table with columns: Test Item, Cover-ages, Rated CBR, No. of Mat Breaks, Differential Deformation (in.), Dist. or Rating, Drabar Pull, Average Total Deflection (in.), and Remarks. It contains data for three lanes (26, 27, 28) and asphalt strip tests.

Note: For lanes 26 and 27, a three-wheel-assembly (loaded to 105 kips) with 56x16, 24-ply tires inflated to 100 psi was used for trafficking. The wheel spacings were 33 in. c-c and 27 in. c-c for lanes 26 and 27, respectively.
* Break types are defined and illustrated in Part I.

Contrails

TABLE 2
SUMMARY OF CBR, DENSITY, AND WATER CONTENT DATA, TEST SECTION 12

Test Item*	Type of Surface	No. of Traffic Coverages	Depth (in.)	CBR	Water Content (%)	Dry Density (lb/cu ft)		
<u>Lane 26</u>								
1	Modified T11 aluminum landing mat	0	0	1.8	30.5	87.6		
			6	2.5	28.2	91.1		
			12	2.2	31.0	87.5		
			18	1.8	31.1	89.1		
		150	0	2.1	32.2	87.4		
			6	2.4	31.5	89.7		
			12	2.4	32.0	88.4		
			18	2.6	31.7	88.1		
		2	M8 steel landing mat	0	0	3.4	28.8	89.7
					6	2.7	27.9	92.4
					12	3.7	29.3	91.1
					18	3.8	28.2	92.5
150	0			4.0	23.9	96.1		
	6			4.7	25.0	94.7		
	12			3.5	29.0	91.1		
	18			3.5	27.8	93.6		
3	Unsurfaced			0	0	9.0	23.6	96.1
					6	10.0	23.0	95.4
					12	10.0	23.8	97.0
					18	11.0	23.4	98.1
		72	0	11.0	23.0	101.6		
			6	11.0	22.2	102.4		
			12	13.0	22.2	100.3		
			18	14.0	23.6	98.6		
		<u>Lane 27</u>						
		1	Modified T11 aluminum landing mat	0	0	1.7	29.5	88.5
					6	2.6	26.4	93.2
					12	2.9	27.6	92.9
18	2.2				29.6	91.7		
68	0			2.5	30.8	89.4		
	6			2.7	29.7	90.8		
	12			2.1	30.7	89.1		
	18			2.1	29.8	89.8		
2	M8 steel landing mat			0	0	3.5	27.0	92.9
					6	3.6	27.4	92.8
					12	4.1	28.0	91.2
					18	6.0	26.2	93.2
		68	0	3.4	26.9	94.7		
			6	3.8	26.7	94.2		
			12	3.6	28.1	91.7		
			18	3.8	28.8	91.1		
		3	Unsurfaced	0	0	11.0	21.9	101.6
					6	10.0	22.7	98.0
					12	9.0	23.3	97.4
					18	10.0	22.0	99.1
30	0			9.0	22.6	99.8		
	6			13.0	21.4	102.8		
	12			10.0	23.5	99.5		
	18			12.0	21.7	101.6		

Note: For coverage-failure information, see remarks column in table 1.

* Subgrade material was heavy clay (buckshot; classified as CH) in all items.

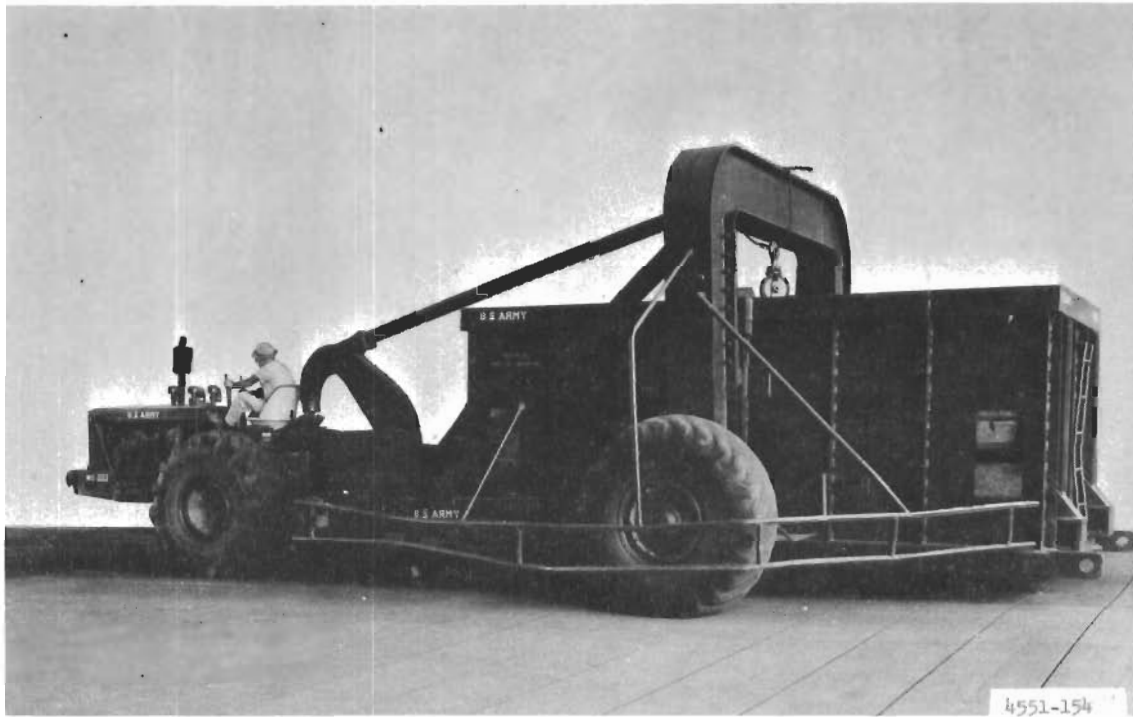

Figure 2. Test load vehicle



Figure 3. Lane 26, item 1, prior to traffic

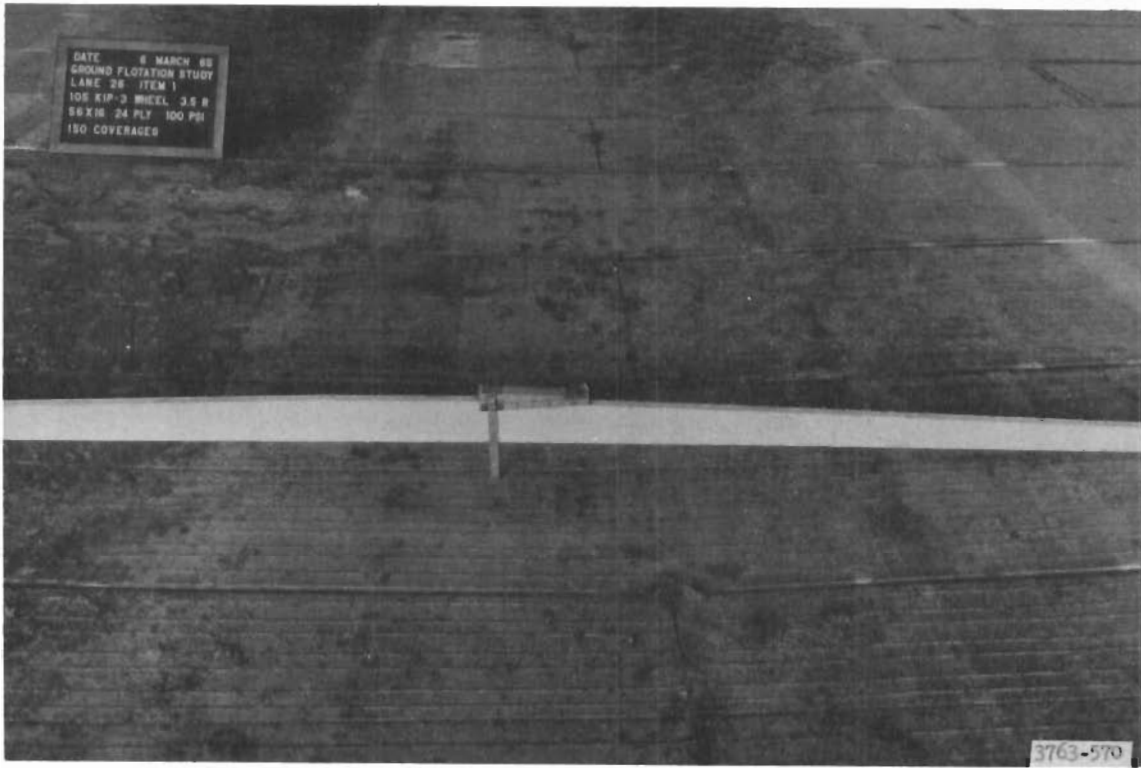

Figure 4. Lane 26, item 1. Transverse straightedge shows roughness at 150 coverages (failure)

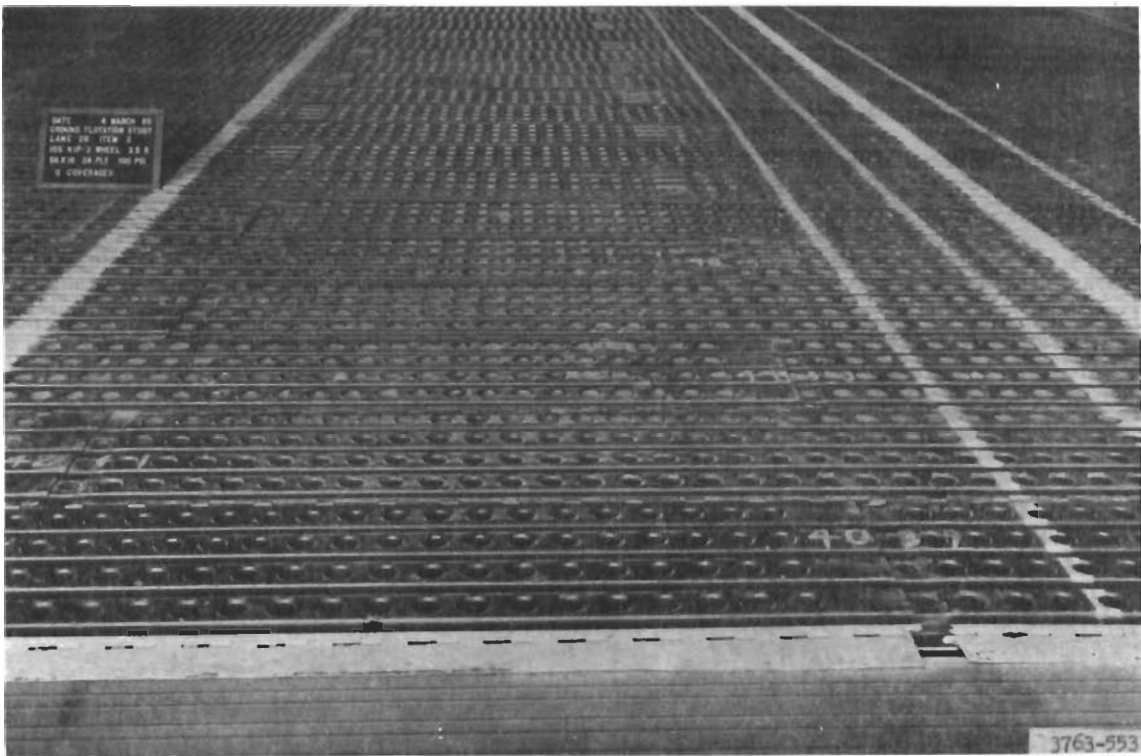

Figure 5. Lane 26, item 2, prior to traffic

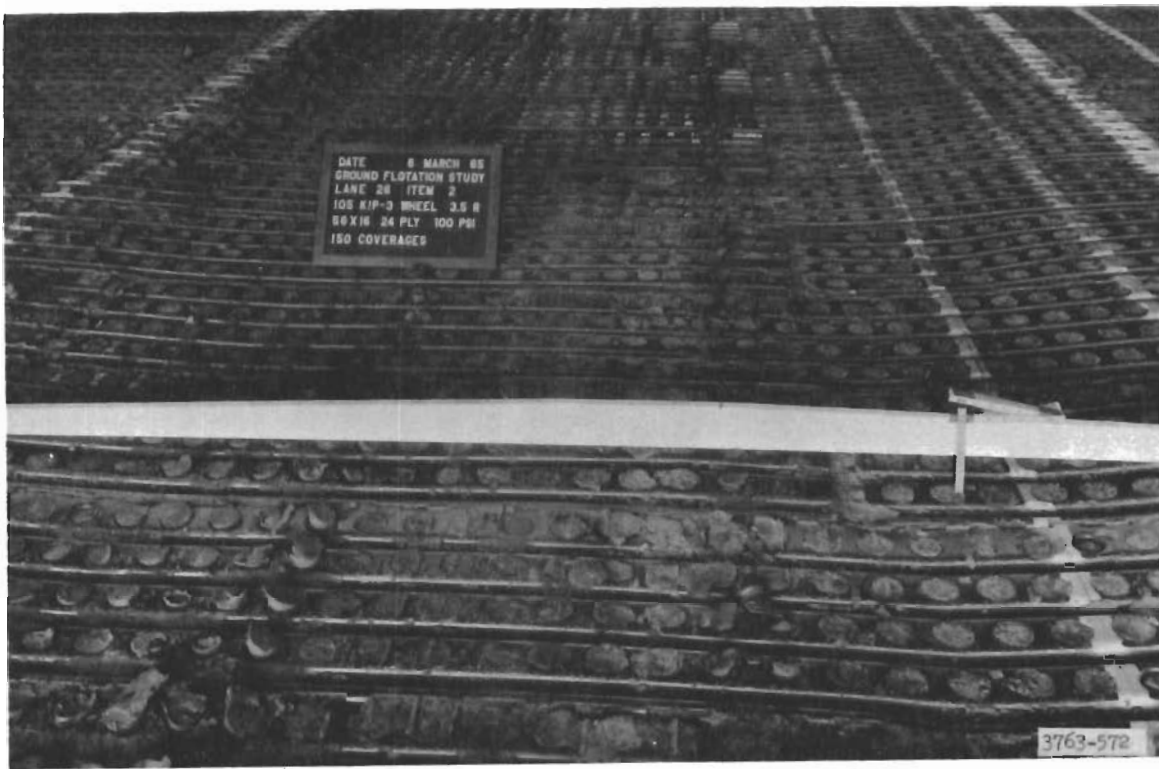

Figure 6. Lane 26, item 2. Transverse straightedge shows roughness at 150 coverages (failure)

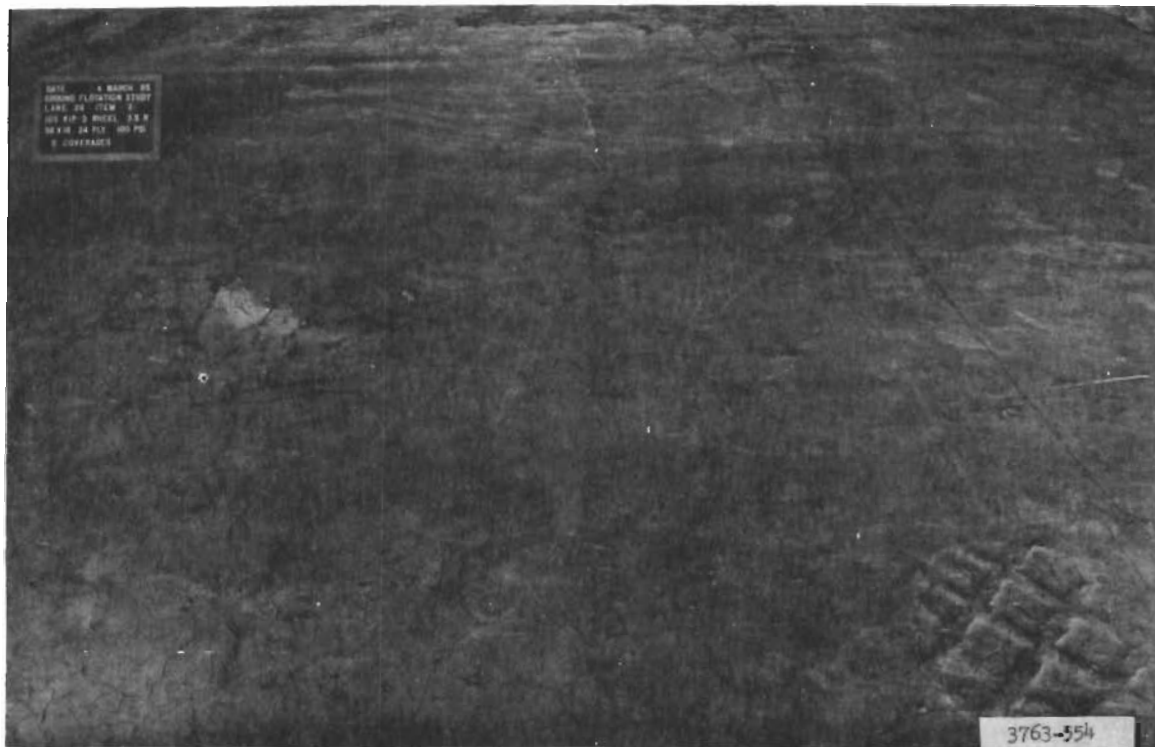

Figure 7. Lane 26, item 3, prior to traffic

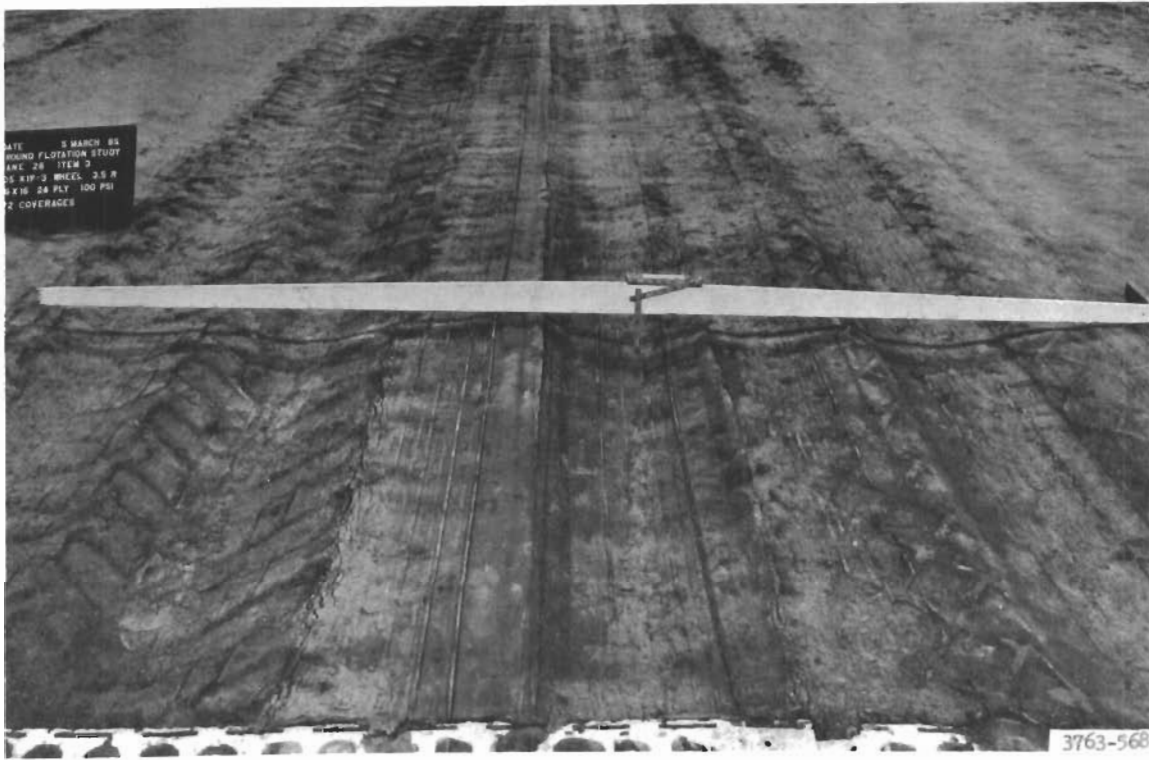

Figure 8. Lane 26, item 3. Transverse straightedge shows roughness at 72 coverages (failure)

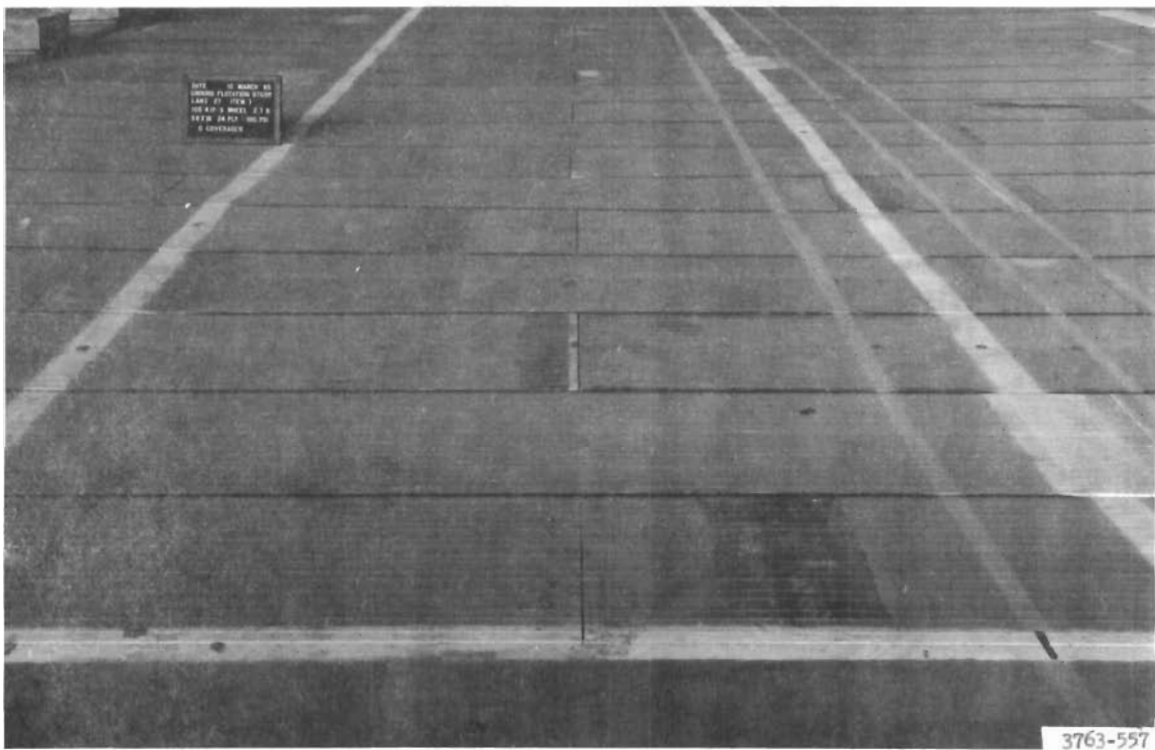

Figure 9. Lane 27, item 1, prior to traffic

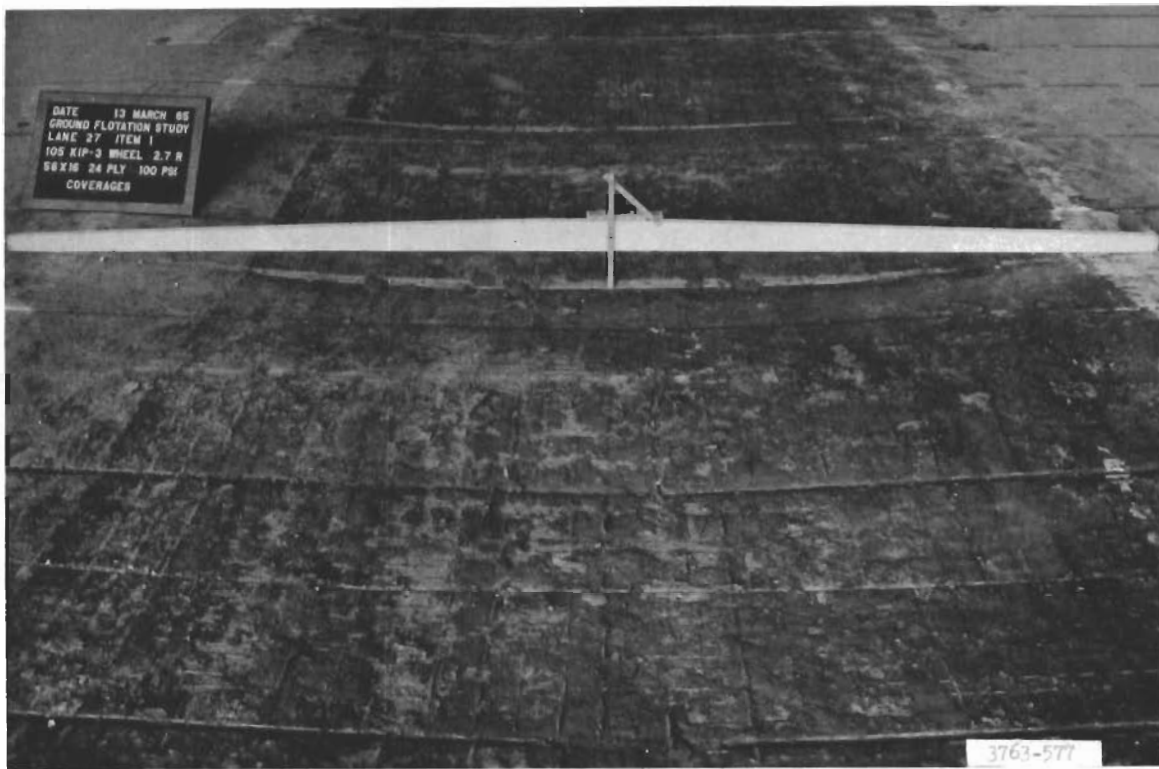

Figure 10. Lane 27, item 1. Transverse straightedge shows roughness at 68 coverages (failure)

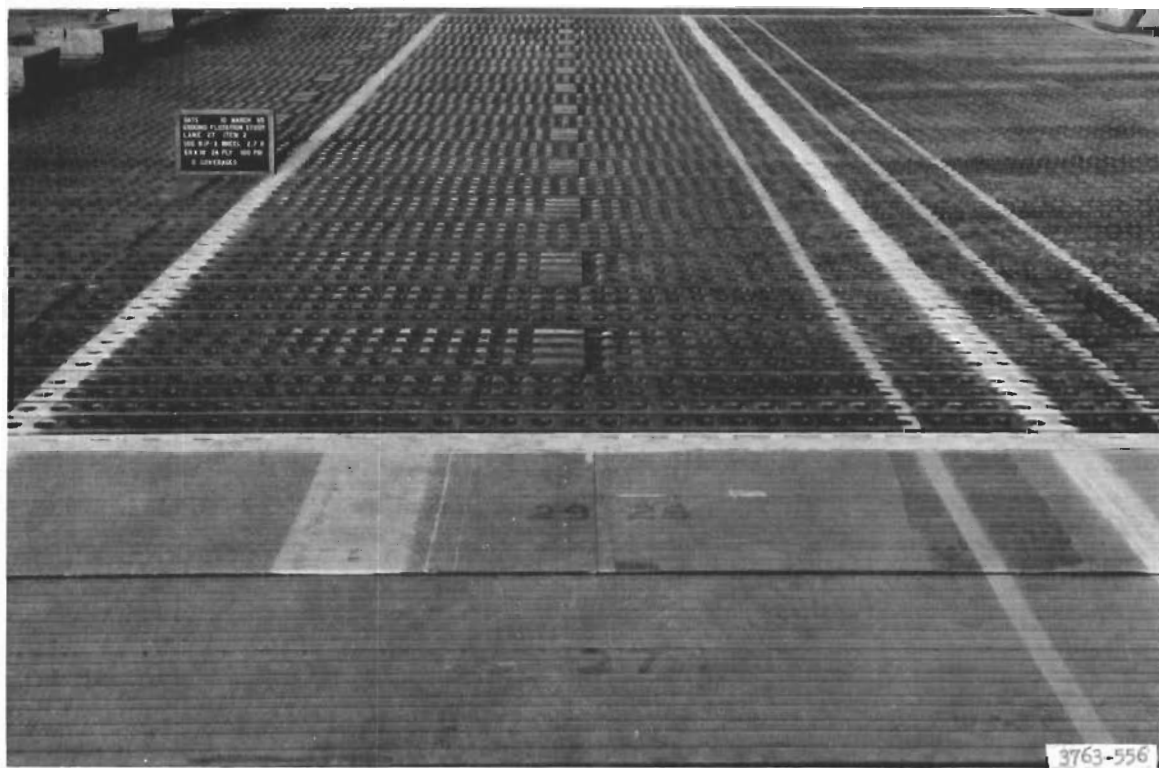

Figure 11. Lane 27, item 2, prior to traffic

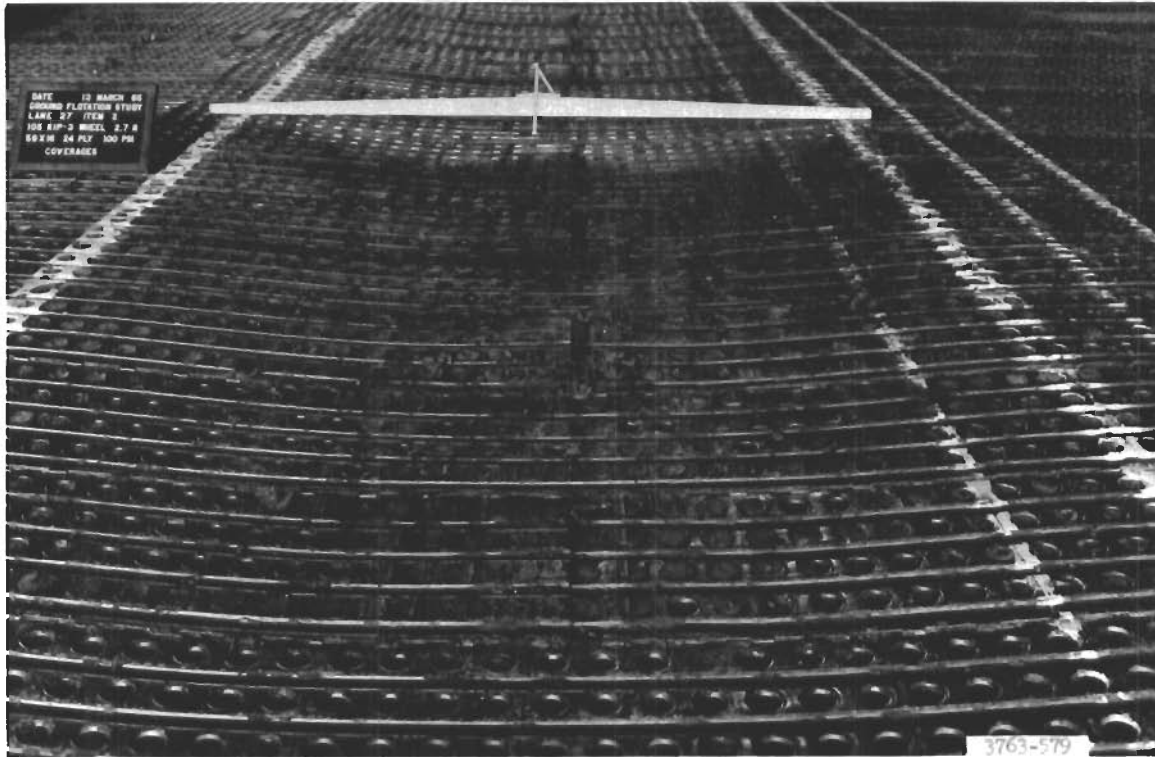

Figure 12. Lane 27, item 2. Transverse straightedge shows roughness at 68 coverages (failure)

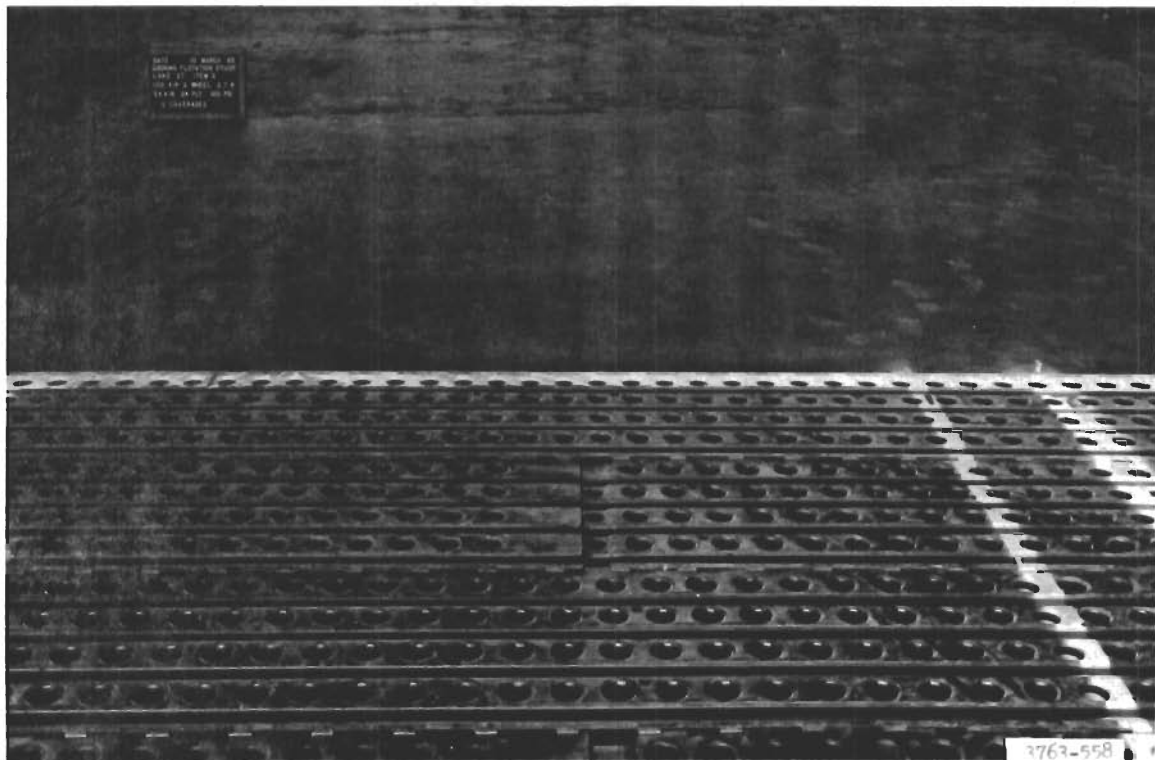

Figure 13. Lane 27, item 3, prior to traffic



Figure 14. Lane 27, item 3. Transverse straightedge shows roughness at 30 coverages (failure)

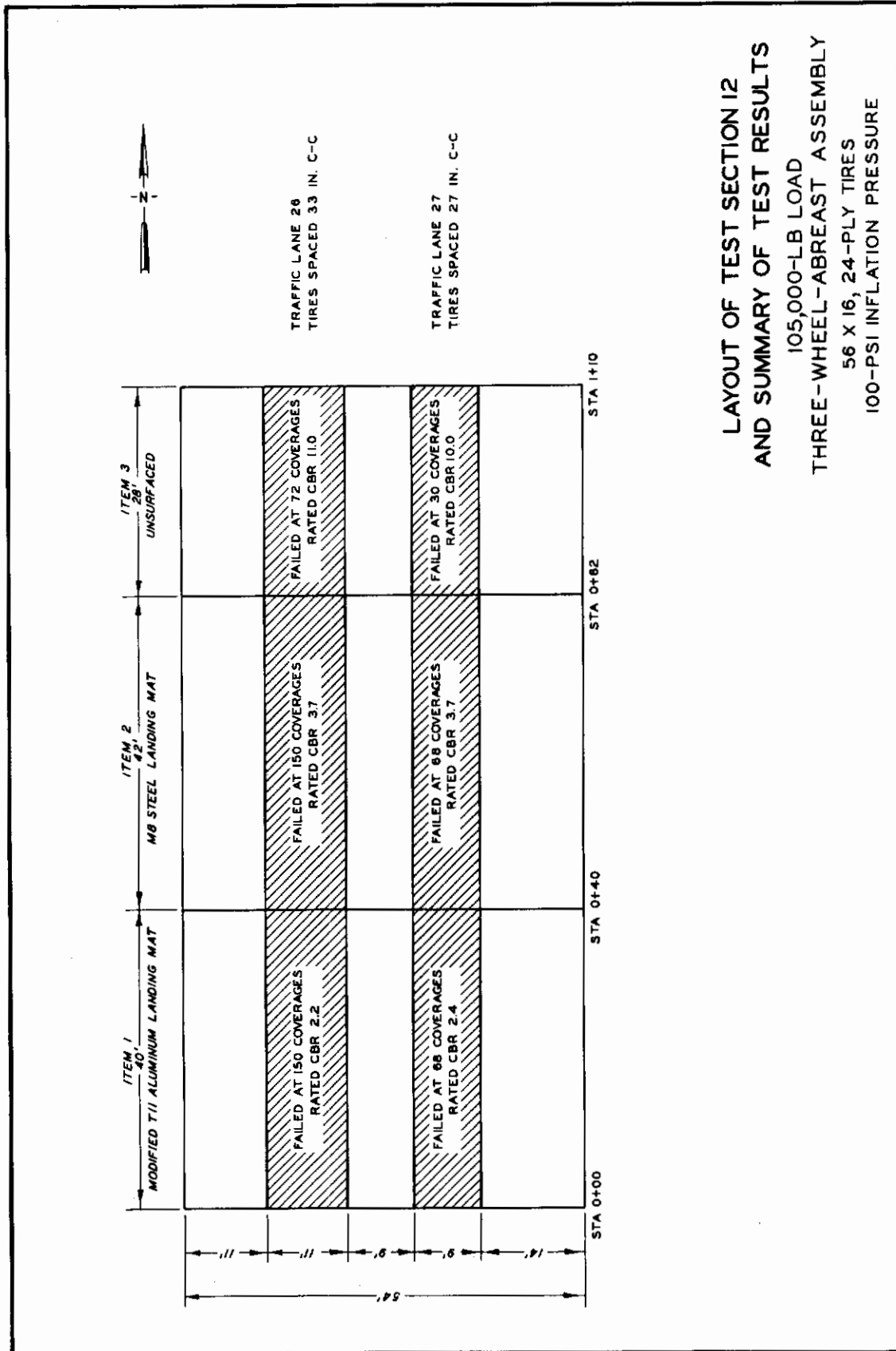
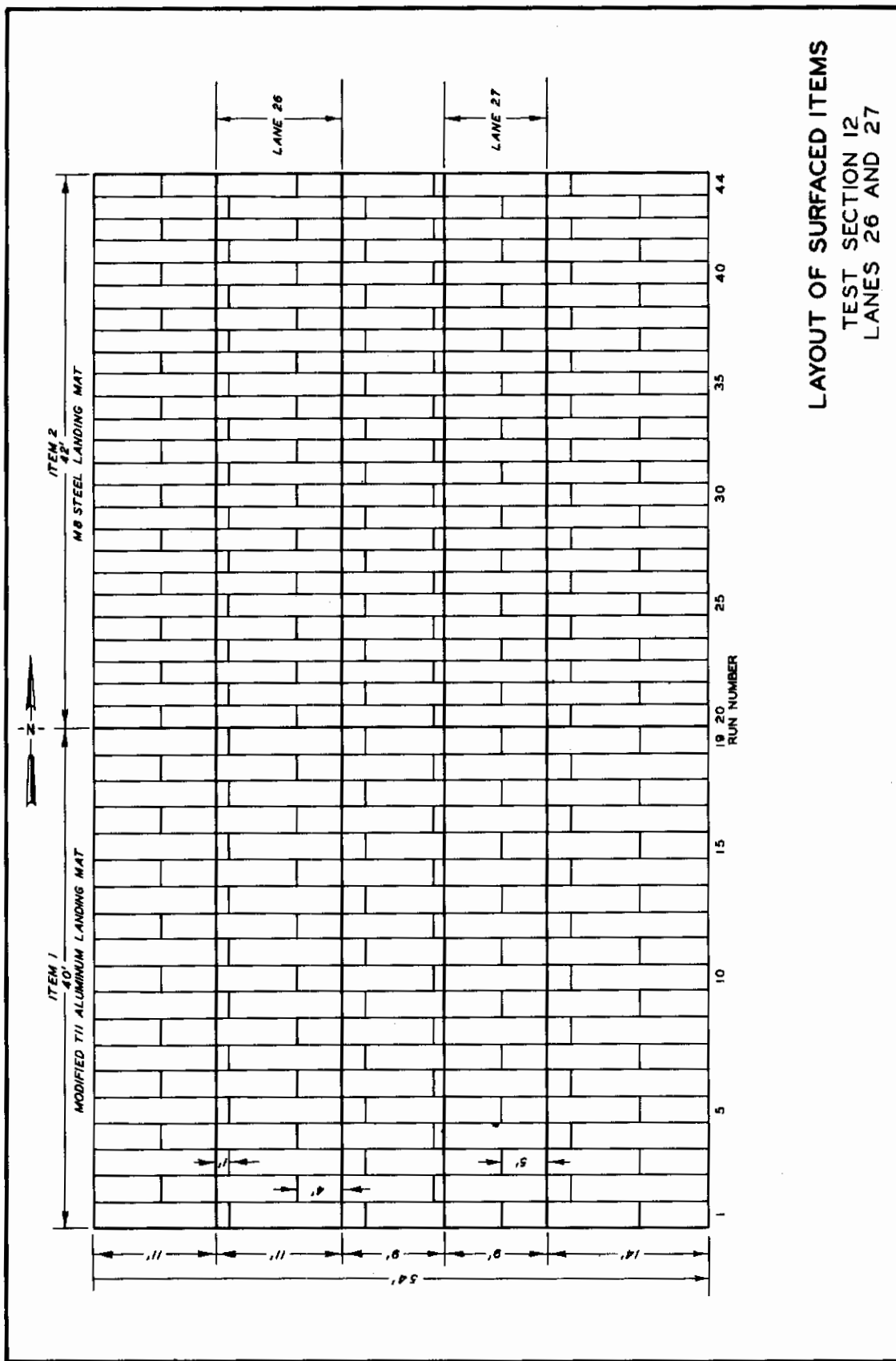
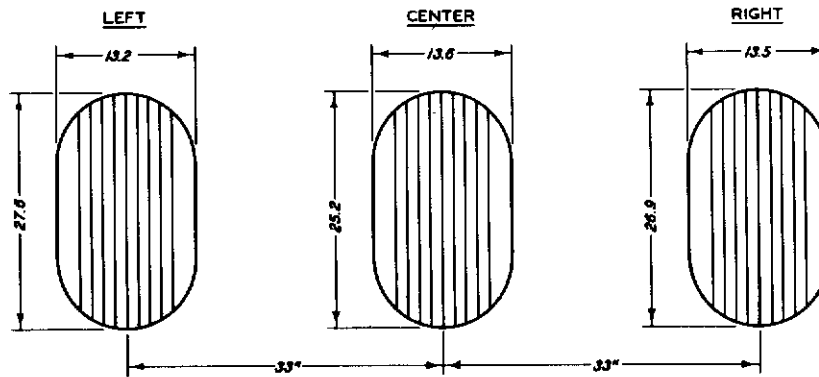

Figure 15



LAYOUT OF SURFACED ITEMS
TEST SECTION 12
LANES 26 AND 27



	LEFT TIRE	CENTER TIRE	RIGHT TIRE
CONTACT AREA, SQ IN.	330	333	335
CONTACT PRESSURE, PSI	108	105	105
INFLATION PRESSURE, PSI	100	100	100
DEFLECTION, %	47	48	44
GROSS ASSEMBLY LOAD = 105,000 LB			

LANE 26

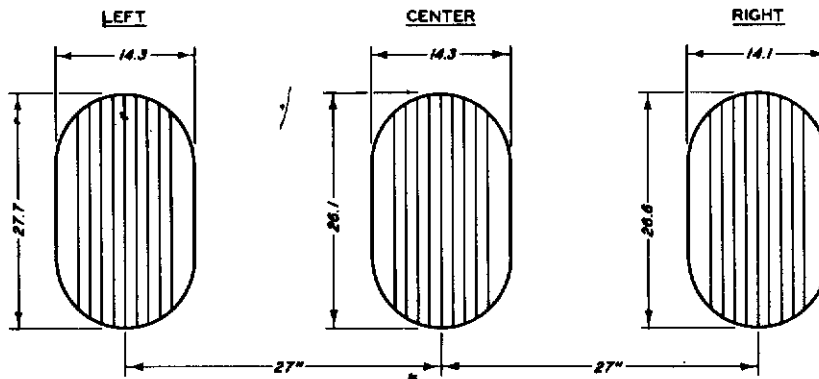

	LEFT TIRE	CENTER TIRE	RIGHT TIRE
CONTACT AREA, SQ IN.	346	334	333
CONTACT PRESSURE, PSI	101	105	105
INFLATION PRESSURE, PSI	100	100	100
DEFLECTION, %	51	45	44
GROSS ASSEMBLY LOAD = 105,000 LB			

LANE 27

**TIRE-PRINT DIMENSIONS AND
TIRE CHARACTERISTICS**

TEST SECTION 12
LANES 26 AND 27
56X16, 24-PLY TIRES

Figure 17

Contrails

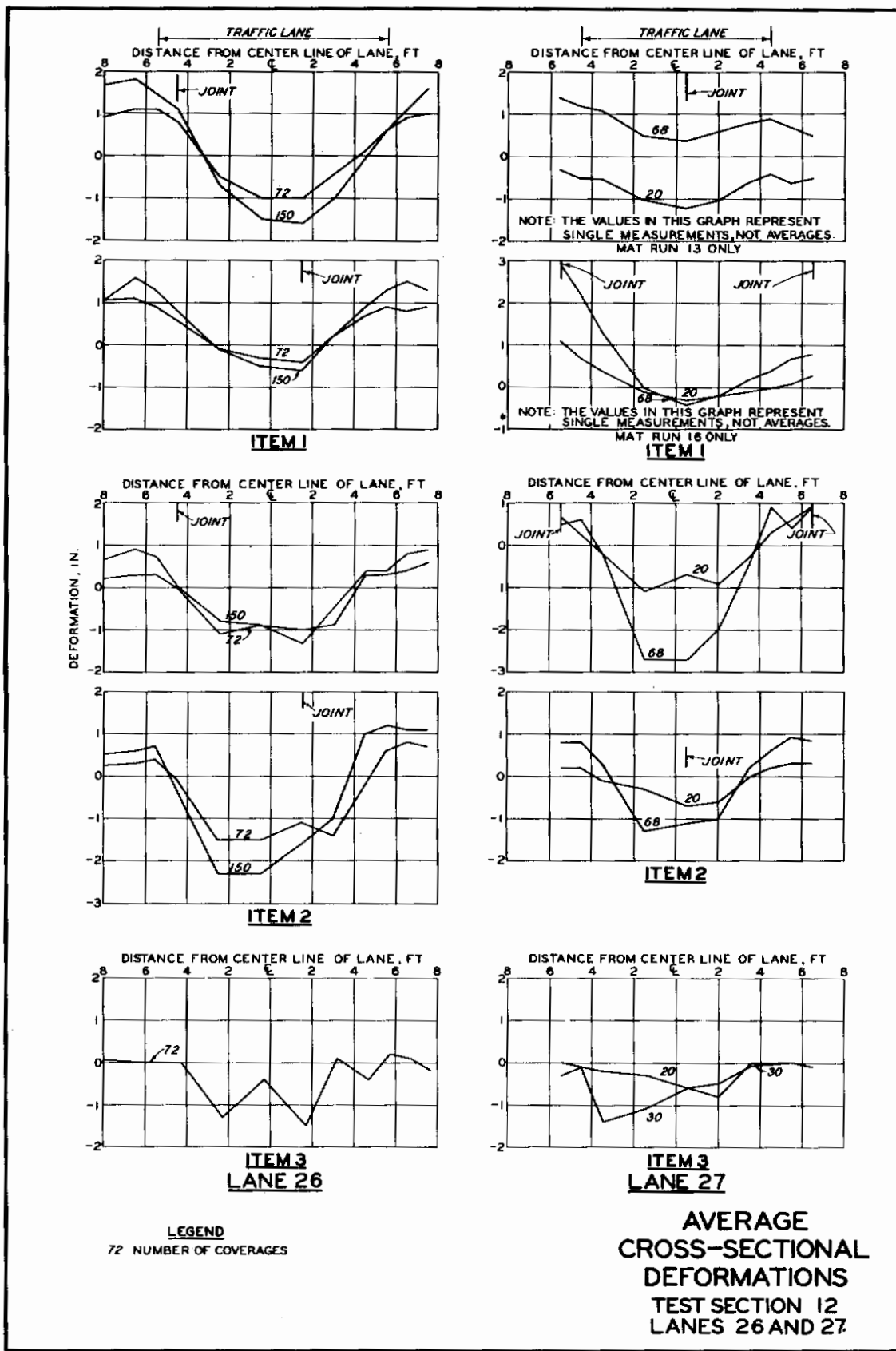
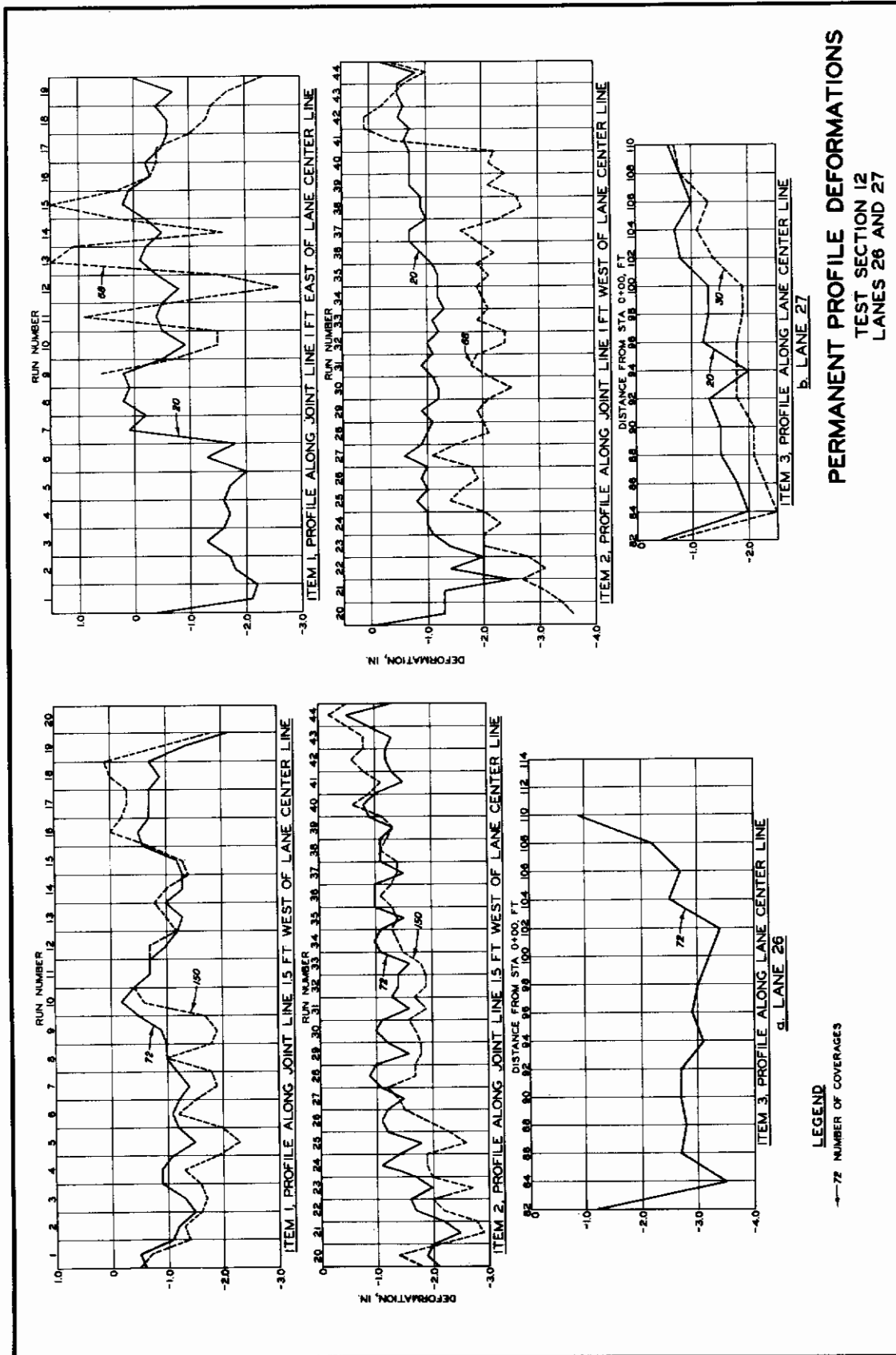

Figure 18



PERMANENT PROFILE DEFORMATIONS
 TEST SECTION 12
 LANES 26 AND 27

Figure 19

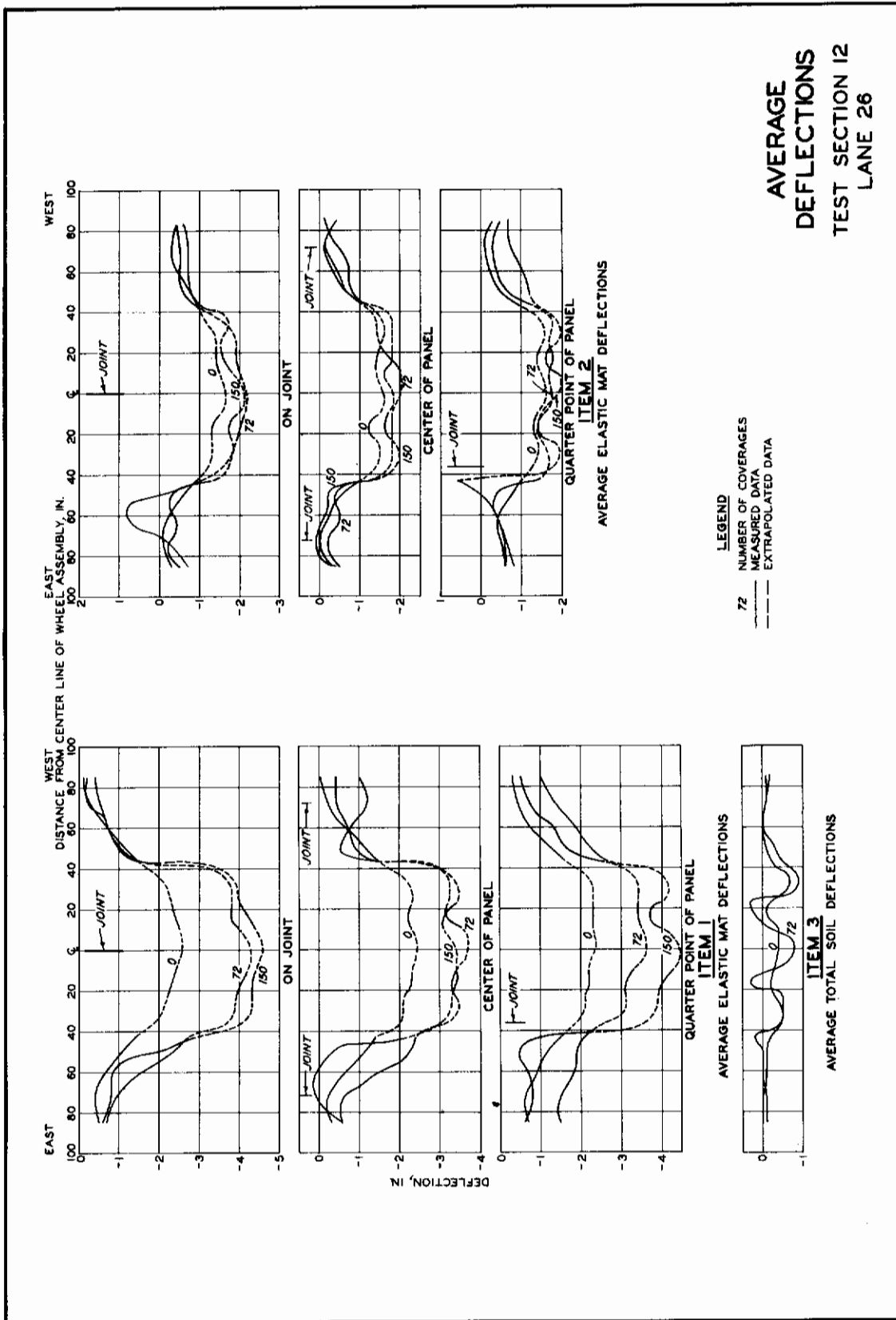

Figure 20

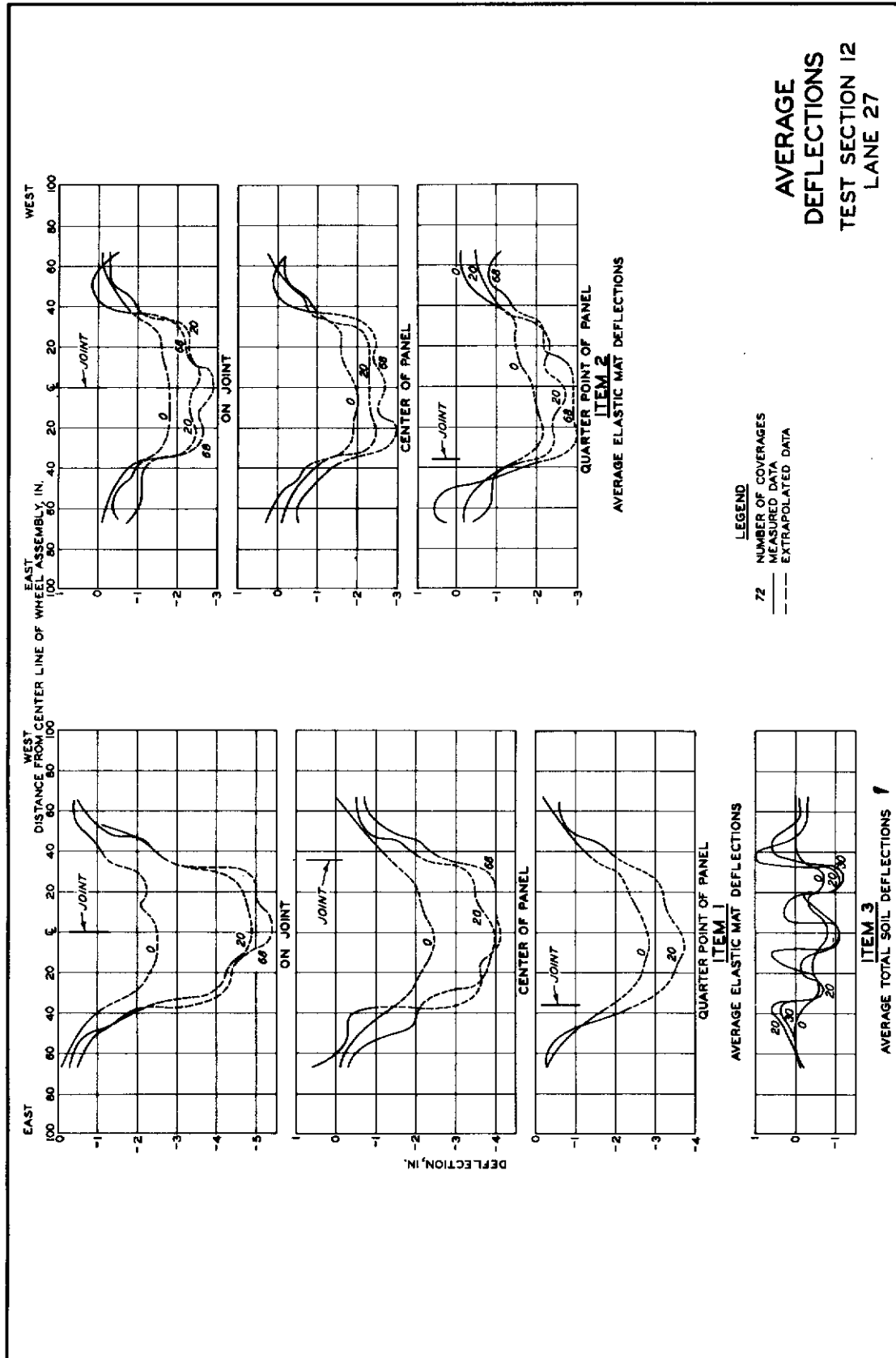

Figure 21

UNCLASSIFIED

Security Classification

DOCUMENT CONTROL DATA - R&D		
<i>(Security classification of title, body of abstract and indexing annotation must be entered when the overall report is classified)</i>		
1. ORIGINATING ACTIVITY (Corporate author) U. S. Army Engineer Waterways Experiment Station		2a. REPORT SECURITY CLASSIFICATION UNCLASSIFIED
		2b. GROUP
3. REPORT TITLE Aircraft Ground-Flotation Investigation Part XII Data Report on Test Section 12		
4. DESCRIPTIVE NOTES (Type of report and inclusive dates) Final Technical Report		
5. AUTHOR(S) (Last name, first name, initial) Brabston, W. N. Hamitt, G. M., III		
6. REPORT DATE September 1966	7a. TOTAL NO. OF PAGES 28	7b. NO. OF REFS
8a. CONTRACT OR GRANT NO. MIPR AS-4-177	8a. ORIGINATOR'S REPORT NUMBER(S) AFFDL-TR-66-43-, Part XII	
b. PROJECT NO. 410A	8b. OTHER REPORT NO(S) (Any other numbers that may be assigned this report) None	
c.		
d.		
10. AVAILABILITY/LIMITATION NOTICES This document is subject to special export controls and each transmittal to foreign governments or foreign nationals may be made only with prior approval of the Air Force Flight Dynamics Laboratory (FFDL), Wright-Patterson AFB, Ohio 45433.		
11. SUPPLEMENTARY NOTES		12. SPONSORING MILITARY ACTIVITY Air Force Flight Dynamics Laboratory Research and Technology Division AF Systems Command, WPAFB, Ohio
13. ABSTRACT This data report describes the results of work undertaken as part of an overall program to develop ground-flotation criteria for the C-5A aircraft.		

DD FORM 1473
1 JAN 64

UNCLASSIFIED

Security Classification

UNCLASSIFIED

Security Classification

14.	KEY WORDS	LINK A		LINK B		LINK C	
		ROLE	WT	ROLE	WT	ROLE	WT
	Aircraft Ground Flotation Rolling Resistance Rear Area Airfields Support Area Airfields Forward Area Airfields Vehicle Mobility						

INSTRUCTIONS

1. **ORIGINATING ACTIVITY:** Enter the name and address of the contractor, subcontractor, grantee, Department of Defense activity or other organization (*corporate author*) issuing the report.
- 2a. **REPORT SECURITY CLASSIFICATION:** Enter the overall security classification of the report. Indicate whether "Restricted Data" is included. Marking is to be in accordance with appropriate security regulations.
- 2b. **GROUP:** Automatic downgrading is specified in DoD Directive 5200.10 and Armed Forces Industrial Manual. Enter the group number. Also, when applicable, show that optional markings have been used for Group 3 and Group 4 as authorized.
3. **REPORT TITLE:** Enter the complete report title in all capital letters. Titles in all cases should be unclassified. If a meaningful title cannot be selected without classification, show title classification in all capitals in parenthesis immediately following the title.
4. **DESCRIPTIVE NOTES:** If appropriate, enter the type of report, e.g., interim, progress, summary, annual, or final. Give the inclusive dates when a specific reporting period is covered.
5. **AUTHOR(S):** Enter the name(s) of author(s) as shown on or in the report. Enter last name, first name, middle initial. If military, show rank and branch of service. The name of the principal author is an absolute minimum requirement.
6. **REPORT DATE:** Enter the date of the report as day, month, year, or month, year. If more than one date appears on the report, use date of publication.
- 7a. **TOTAL NUMBER OF PAGES:** The total page count should follow normal pagination procedures, i.e., enter the number of pages containing information.
- 7b. **NUMBER OF REFERENCES:** Enter the total number of references cited in the report.
- 8a. **CONTRACT OR GRANT NUMBER:** If appropriate, enter the applicable number of the contract or grant under which the report was written.
- 8b, 8c, & 8d. **PROJECT NUMBER:** Enter the appropriate military department identification, such as project number, subproject number, system numbers, task number, etc.
- 9a. **ORIGINATOR'S REPORT NUMBER(S):** Enter the official report number by which the document will be identified and controlled by the originating activity. This number must be unique to this report.
- 9b. **OTHER REPORT NUMBER(S):** If the report has been assigned any other report numbers (*either by the originator or by the sponsor*), also enter this number(s).
10. **AVAILABILITY/LIMITATION NOTICES:** Enter any limitations on further dissemination of the report, other than those

imposed by security classification, using standard statements such as:

- (1) "Qualified requesters may obtain copies of this report from DDC."
- (2) "Foreign announcement and dissemination of this report by DDC is not authorized."
- (3) "U. S. Government agencies may obtain copies of this report directly from DDC. Other qualified DDC users shall request through _____."
- (4) "U. S. military agencies may obtain copies of this report directly from DDC. Other qualified users shall request through _____."
- (5) "All distribution of this report is controlled. Qualified DDC users shall request through _____."

If the report has been furnished to the Office of Technical Services, Department of Commerce, for sale to the public, indicate this fact and enter the price, if known.

11. **SUPPLEMENTARY NOTES:** Use for additional explanatory notes.

12. **SPONSORING MILITARY ACTIVITY:** Enter the name of the departmental project office or laboratory sponsoring (*paying for*) the research and development. Include address.

13. **ABSTRACT:** Enter an abstract giving a brief and factual summary of the document indicative of the report, even though it may also appear elsewhere in the body of the technical report. If additional space is required, a continuation sheet shall be attached.

It is highly desirable that the abstract of classified reports be unclassified. Each paragraph of the abstract shall end with an indication of the military security classification of the information in the paragraph, represented as (TS), (S), (C), or (U).

There is no limitation on the length of the abstract. However, the suggested length is from 150 to 225 words.

14. **KEY WORDS:** Key words are technically meaningful terms or short phrases that characterize a report and may be used as index entries for cataloging the report. Key words must be selected so that no security classification is required. Identifiers, such as equipment model designation, trade name, military project code name, geographic location, may be used as key words but will be followed by an indication of technical context. The assignment of links, rules, and weights is optional.

UNCLASSIFIED

Security Classification