

FDL-TDR-64-70

## **AIRCRAFT MOTION ANALYSIS**

*J. A. THELANDER*

## FOREWORD

The material contained in this report was prepared originally under USAF Contract No. AF 33(616)-6460, under Task Nr. 821902 of Project Nr. 8219, as part of a USAF Stability and Control Handbook development. It is published separately as a Technical Documentary Report in keeping with the Air Force policy to restrict the handbook to basic stability and control data. The work was conducted under the cognizance of the Control Criteria Branch, Air Force Flight Dynamics Laboratory, Research and Technology Division, with Mr. D. E. Hoak serving as project engineer.

The contribution of Dr. M. J. Abzug as advisor, consultant, and critic is gratefully acknowledged.

## ABSTRACT

This report is a compilation of coordinate systems, equations, and general relations used in aircraft-motion analysis. The information presented is useful for comparative evaluation and for preliminary-design work. Simplified and approximate solutions are given for special flight conditions. The material is defined and presented in a form suitable for direct application. Derivation and theoretical development are not emphasized, but sources thereof are named.

This technical documentary report has been reviewed and is approved.

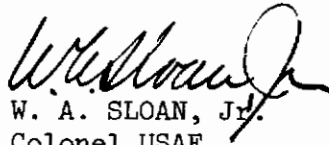

W. A. SLOAN, JR.  
Colonel, USAF  
Chief, Flight Control Division  
AF Flight Dynamics Laboratory

TABLE OF CONTENTS

	Page
SECTION 1. INTRODUCTION .....	1
SECTION 2. COORDINATE SYSTEMS AND EQUATIONS OF MOTION .....	2
Particle Motion .....	2
Rectangular-Coordinate System .....	2
Spherical-Coordinate System .....	3
1. Rotating-Earth Spherical Coordinates .....	6
2. Rotating-Earth Flight-Path Coordinates .....	6
3. Nonrotating-Earth Spherical Coordinates .....	6
4. Nonrotating-Earth Flight-Path Coordinates .....	7
Cylindrical-Polar Coordinate System .....	7
Rigid-Body Motion .....	8
Earth Axes .....	9
Body Axes .....	11
Stability Axes .....	13
Principal Axes .....	14
General Wind Axes .....	15
Symmetric Wind Axes .....	16
Wind-Tunnel Stability Axes .....	16
Nonrolling Axes .....	17
SECTION 3. COORDINATE-SYSTEM TRANSFORMATIONS .....	18
Particle-Motion Transformations .....	18
Rectangular Coordinates .....	18
1. Planar Rotation .....	19
2. General Rotation .....	21
3. Rectangular Coordinates to Curvilinear Coordinates .....	25
Spherical Coordinates .....	26
Cylindrical Coordinates .....	28
Rigid-Body Transformations .....	29
General Axes Transformations .....	29
Vehicle Transformations .....	31
1. Single Rotation .....	31
2. Multiple Rotation .....	39
SECTION 4. REAL FORCES AND MOMENTS .....	44
General Force and Moment Description .....	44
Gravity-Force Components .....	45
Aerodynamic Forces and Moments .....	45
Thrust Forces and Moments .....	50
Stability Derivatives .....	51
Dimensional Derivatives—Body Axes .....	51
Nondimensional Derivatives—Body Axes .....	52
Nondimensional Derivatives—Stability Axes .....	52
SECTION 5. SIMPLIFICATION OF THE EQUATIONS OF MOTION .....	64
General Simplification of Rigid-Body Equations .....	64
Simplification of Equations of Motion for Steady-Flight Conditions .....	67
Steady, Straight Flight .....	67
Steady Turns .....	68
Steady Pitching Flight .....	68
Steady Rolling or Spinning Flight .....	69
Linearization for Steady, Straight, Symmetric Initial Flight .....	69
Linearization for Steady Maneuvering Flight .....	73
Additional Specialized Forms of the Equations of Motion .....	75
Large Disturbances from Steady, Straight, Symmetric Flight .....	76
Equations of Motion Along Wind Axes .....	77

# Contrails

## TABLE OF CONTENTS (Cont'd)

SECTION 6. SOLUTION OF THE EQUATIONS OF MOTION .....	78
Analytical Methods .....	78
Direct Method of Solution .....	78
Laplace-Transform Method of Solution .....	81
Matrix Method of Solution .....	82
Computer Methods of Solution .....	82
Digital Computer .....	83
Analog Computer .....	83
Approximate Solutions .....	83
Approximate Formulas for Small-Disturbance Motion .....	84
Approximate Formulas for Response to Control Input .....	84
1. Load Factor Due to Control Deflection .....	84
2. Maximum Roll Velocity .....	85
3. Maximum Angular Acceleration .....	85
SECTION 7. SPECIAL PROBLEMS .....	86
Instrument Readings .....	86
Attitude-Measuring Instrument Readings .....	86
Velocity-Measuring Instrument Readings .....	87
Acceleration-Measuring Instrument Readings .....	89
Fuel Slosh .....	90
Conditions Under Which Fuel Slosh Has Been Found to be Significant .....	90
Motion of Sloshing Fuel .....	91

## ILLUSTRATIONS

Figure	Page
1. General Rectangular-Coordinate System .....	2
2. Rotating-Earth Coordinate System .....	4
3. Cylindrical-Coordinate System .....	7
4. Relationships Between Moving and Fixed Earth Axes and Vehicle Body Axes .....	10
5. Vehicle Body Axes .....	12
6. Stability Axes .....	13
7. Principal Axes .....	14
8. General Wind Axes .....	15
9. Wind-Tunnel Stability Axes .....	17
10. Translation of Origin .....	18
11. Rotation in the X-Y Plane .....	19
12. General Rotation About Origin. Orientation-Angle Description of Rotation .....	21
13. General Rotation About Origin. Direction-Cosine Description of Rotation .....	24
14. Rectangular-Spherical Coordinates .....	25
15. Rectangular-Cylindrical Coordinates .....	26
16. Rotation of Base Vectors from Spherical to Flight-Path Coordinates .....	28
17. Body-Stability-Principal Axes Rotation. Pitch .....	32
18. Rotation from Wind-Tunnel to Vehicle Axes. Yaw-Pitch Sequence. ....	39
19. Rotation from Earth to Body Axes. Yaw-Pitch-Roll Sequence .....	40
20. Rotation from Wind to Body Axes. Yaw-Pitch Sequence .....	41
21. Rotation from Wind to Body Axes. Pitch-Yaw Sequence .....	43
22. Angles of Attack and Sideslip .....	46
23. Aerodynamic-Force Resolution .....	47
24. Types of Motion for Different Roots of the Characteristic Equation .....	80
25. Conventional Free Vertical and Directional Gyro Systems .....	86
26. General Instrument Axes .....	88
27. Single-Degree-of-Freedom Analog to Sloshing Fuel .....	91
28. Natural Frequency of Fuel-Slosh Fundamental Mode for Various Fuel-Tank Shapes .....	92
29. Natural Frequency of Fuel Slosh in Open-Top Rectangular Fuel Tanks .....	94
30. Effective Mass of Fuel-Slosh Fundamental Mode for Various Fuel-Tank Shapes .....	95

## TABLES

Table	Page
1. Vector Transformation Matrix. Initial Axes to Rotated Axes .....	20
2. Rectangular-Coordinate Transformations. Rotation of Axes About Origin .....	23
3. Vector Transformation Matrix of Direction Cosines .....	24
4. Correspondence Between Rectangular-Coordinate Transformation and Spherical-Flight-Path- Coordinate Transformation .....	27
5. Vector Transformation Matrix. Spherical Coordinates to Flight-Path Coordinates .....	27
6. Vector Transformation Matrices. Body-Stability-Principal Axes .....	32
7. Inertia Matrix Element Transformations. Body-Stability-Principal Axes .....	34
8. Stability-Derivative Transformations. Stability Axes to Body Axes .....	37
9. Stability-Derivative Transformations. Body Axes to Stability Axes .....	38
10. Vector Transformation Matrices. Wind-Tunnel Axes to Wind-Tunnel Stability Axes to Vehicle Stability Axes .....	38
11. Vector Transformation Matrix. Earth to Body Axes. ....	40
12. Angular-Velocity Relations. Earth to Body Axes .....	41
13. Vector Transformation Matrix. General Wind to Body Axes .....	42
14. Angular-Velocity Relations. General Wind to Body Axes .....	42
15. Vector Transformation Matrix. General Wind to Body Axes .....	42
16. Angular-Velocity Relations. General Wind to Body Axes .....	43
17. Aerodynamic Force and Moment Increments for Small Disturbances .....	50
18. Symbols and Notation. Stability Derivatives and Related Parameters .....	53
19. Nondimensional Stability Derivatives. Body Axes .....	57
20. Nondimensional Stability Derivatives. Stability Axes .....	59
21. Nondimensional Equations of Motion for Small Disturbances From Steady, Straight, Symmetric Flight. Body Axes .....	71
22. Nondimensional Equations of Motion for Small Disturbances From Steady, Straight, Symmetric Flight. Stability Axes .....	72
23. General Equations of Motion for Small Disturbances From Steady Flight. Stability Axes .....	73
24. Initial Conditions for General Small-Disturbance Equations of Motion. Stability Axes .....	74
25. Quantitative Characteristics of Modes of Motion .....	81
26. Approximate Formulas for Small-Disturbance Motion .....	84
27. Some Conditions Under Which Fuel Sloth has Significant Effects on Vehicle Rigid-Body Modes of Motion .....	90

# *Contrails*



## SECTION 1. INTRODUCTION

Data and information are presented in this report for use in the analysis of aircraft motion. This report, which was originally intended to be a part of the USAF Stability and Control Handbook published in October 1960, is a compilation and condensation of the coordinate systems, equations, and general information related to aircraft-motion analysis. The original form remains essentially unchanged.

The purpose of the Handbook was to provide the data, equations, and relations necessary to analyze the motions, the stability and control characteristics, and flying qualities of aircraft in concise, consistent, and readily usable form. In keeping with this purpose, emphasis is placed on description, definition, and application rather than on derivation and theoretical development. Problems of unusual nature and unconventional configurations may require special analysis and development of particular equations from the fundamental theory cited in the references.

The basic kinematic and dynamic relations for particle and rigid-body motion are included. Several convenient coordinate systems are defined, and coordinate transformation relations are given. Force and moment components are developed, and a compilation of conventional stability derivatives is presented. The rigid-body equations of motion are simplified for special flight conditions, and some approximate solutions are given. Some material is presented pertaining to instrument readings and fuel slosh.

Symbols and nomenclature are listed and defined in the sections to which they apply. Consistency in symbols and notation is maintained, except in cases where established usage dictates otherwise. A complete list of symbols is not considered to be necessary and is not given.

## SECTION 2. COORDINATE SYSTEMS AND EQUATIONS OF MOTION

In order to describe the motion of a dynamic system it is necessary to define a suitable coordinate system and formulate equations for the motion in accordance with the physical laws governing the system.

The diagrams and discussion that follow consider the motion of a particle (point mass) and the more complicated motion of a rigid body.

### PARTICLE MOTION

Coordinate systems and equations that conveniently describe the motion of a point mass are presented in the following pages. Rectangular, spherical, and cylindrical coordinate systems are presented. Preferred axis orientation and notation indicated and used are consistent, insofar as possible, with the reference literature.

#### RECTANGULAR-COORDINATE SYSTEM (FLAT NONROTATING EARTH)

The familiar Cartesian or rectangular coordinate system has many applications in the analysis of vehicle motion. For instance, it may be used to describe the flight path (trajectory) of a body with respect to a given starting point on the earth's surface. A typical case is suggested in the description of the coordinate system below. Generalization to any specific problem is self-evident and requires no further discussion.

##### Description of Coordinate System

Origin of rectangular coordinates  $x$ ,  $y$ ,  $z$ : arbitrary, often a point on the surface of the earth.

Fundamental plane: usually the  $XY$ -plane; tangent to the surface of the earth at the origin.

Positive  $X$ -axis: arbitrary, often selected along initial heading or direction of motion.

Positive  $Z$ -axis: arbitrary, often oriented in sense to denote altitude above the surface of earth or the  $XY$ -plane.

Positive rotation in fundamental plane: from  $X$ -axis to  $Y$ -axis; i.e., right-hand system.

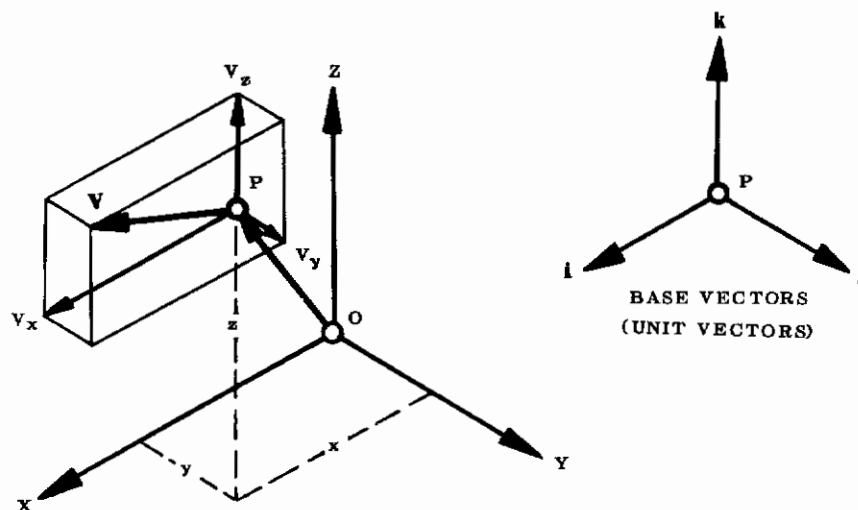

FIGURE 1 GENERAL RECTANGULAR-COORDINATE SYSTEM

## NOTATION

<b>i, j, k</b>	orthonormal base (unit) vectors along X-, Y-, and Z-axes, respectively
<b>OP</b>	position vector of point P (rectangular coordinates x, y, z)
<b>x, y, z</b>	position coordinates of P; also components of <b>OP</b> along coordinate axes, i.e., <b>OP</b> = xi + yj + zk
<b>V</b>	velocity vector of point P
<b>V<sub>x</sub>, V<sub>y</sub>, V<sub>z</sub></b>	components of velocity <b>V</b> along the coordinate-axis directions, i.e., <b>V</b> = V <sub>x</sub> i + V <sub>y</sub> j + V <sub>z</sub> k
<b>m</b>	mass of particle at point P
<b>(<math>\dot{\phantom{x}}</math>)</b>	denotes differentiation with respect to time

### Equations of Motion

Vector form:

$$\mathbf{F} = m \frac{d\mathbf{V}}{dt} = m \dot{\mathbf{V}} \quad (1)$$

Component form:

$$\left. \begin{aligned} F_x &= m \dot{V}_x = m \ddot{x} \\ F_y &= m \dot{V}_y = m \ddot{y} \\ F_z &= m \dot{V}_z = m \ddot{z} \end{aligned} \right\} \quad (2)$$

## SPHERICAL-COORDINATE SYSTEM

The analysis of motions within the inertial frame fixed to the center of the earth is most conveniently treated in spherical coordinates. This section considers both rotating and nonrotating spherical coordinates. In order to distinguish between these two systems, primed quantities refer to nonrotating coordinates and unprimed quantities refer to rotating coordinates. Since it is customary to refer our position and velocity to the earth, the rotating coordinates are generally used.

Flight-path coordinates are introduced because aerodynamic forces are frequently considered in the analysis of a vehicle flight path. Aerodynamic forces are most conveniently related to the velocity of the vehicle through the air, which rotates with the earth. Thus the rotating-earth flight-path coordinates may be used in the analysis of missile and supersonic- or hypersonic-vehicle flight paths whenever aerodynamic forces are included.

The basic development of the equations of motion in this Section is given in reference 1.

### Description of Coordinate System (reference 2)

Origin of spherical coordinates  $r, \phi, \theta$ : center of the earth.

Fundamental plane: equatorial plane.

Reference direction in fundamental plane: arbitrary, e.g., Greenwich Meridian used for longitude reference.

Polar-axis positive direction: toward the North Pole.

Positive rotation in fundamental plane: eastward, i.e., a right-hand system.

## NOTATION

<b>O</b>	origin of rotating spherical coordinate system, center of the earth
<b>P</b>	particle under consideration

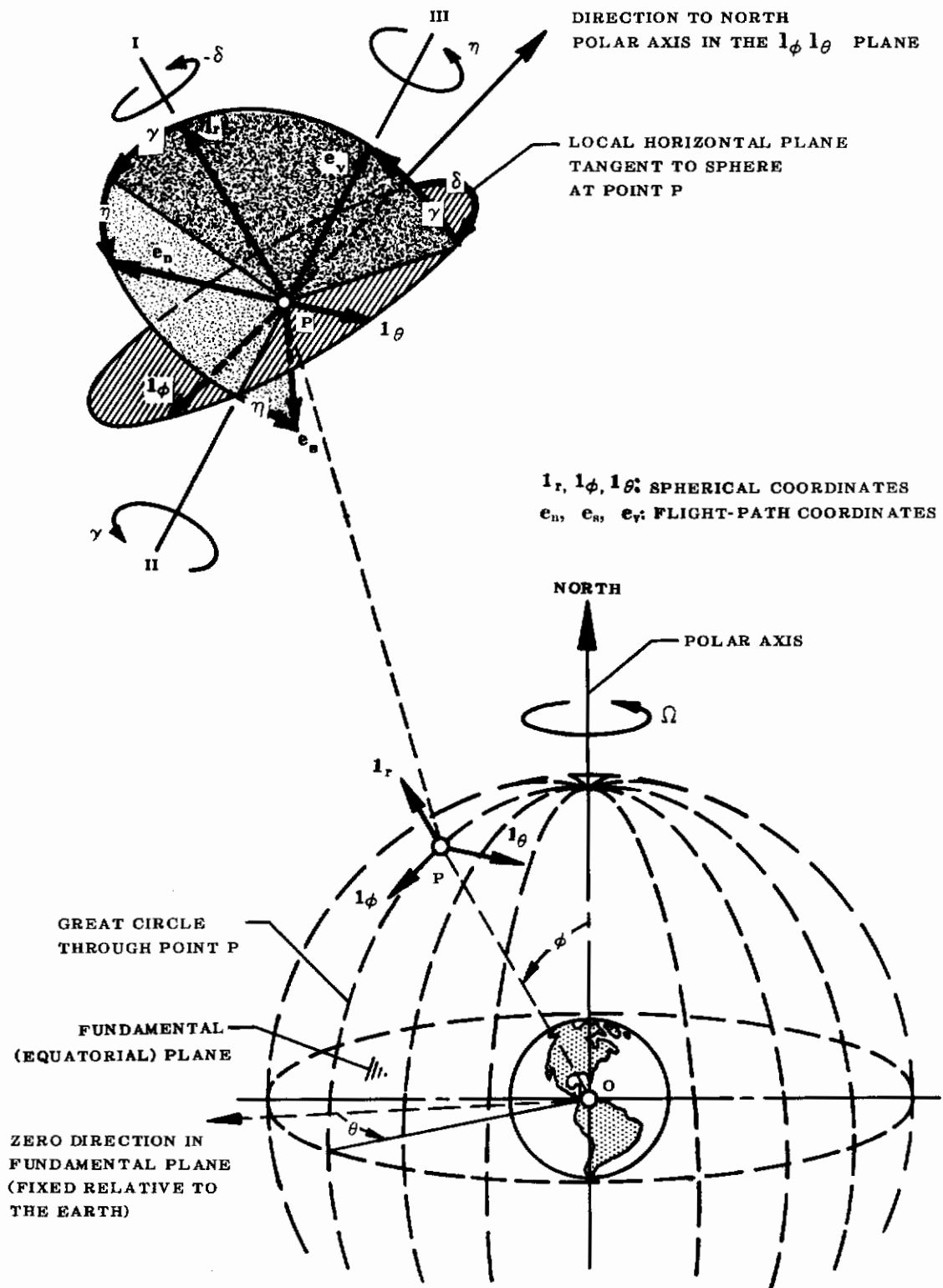

FIGURE 2 ROTATING-EARTH COORDINATE SYSTEM

# Contrails

<b>OP</b>	position vector of P (spherical coordinates $r, \phi, \theta$ )
<b>r</b>	radial distance from origin to P
<b><math>\phi</math></b>	angular inclination of P to polar axis
<b><math>\theta</math></b>	angular displacement of P from reference meridian plane (reference plane rotates with the earth)
<b><math>\Omega</math></b>	angular velocity of rotating coordinate system about the polar axis
<b><math>\mathbf{i}_r, \mathbf{i}_\phi, \mathbf{i}_\theta</math></b>	orthonormal base (unit) vectors at P along spherical-coordinate directions
<b>V</b>	velocity vector of P with respect to rotating coordinates
<b>V</b>	magnitude of velocity vector V
<b><math>V_r, V_\phi, V_\theta</math></b>	components of velocity V along the coordinate directions, i.e., $\mathbf{V} = V_r \mathbf{i}_r + V_\phi \mathbf{i}_\phi + V_\theta \mathbf{i}_\theta$
<b><math>\mathbf{e}_n, \mathbf{e}_s, \mathbf{e}_v</math></b>	orthonormal base (unit) vectors at P along flight-path coordinates ( $\mathbf{e}_v$ is aligned along the velocity vector V; $\mathbf{e}_n$ and $\mathbf{e}_s$ are oriented normal and sidewise, respectively, to the flight path)
<b><math>\delta</math></b>	flight-path heading — the angle between the meridian plane through P and the flight plane determined by the radius vector OP and velocity vector V. The angle $\delta$ is measured clockwise from the polar axis.
<b><math>\gamma</math></b>	flight-path attitude — the angle between the velocity vector V and the local horizon at P
<b><math>\eta</math></b>	roll angle — the angular displacement of the base vector $\mathbf{e}_n$ from the flight plane containing OP and V. The angle $\eta$ is positive in the sense of a right-hand rotation about $\mathbf{e}_v$ .
<b>F</b>	real force vector applied at P
<b><math>F_r, F_\phi, F_\theta</math></b>	components of F along spherical-coordinate directions, i.e., $\mathbf{F} = F_r \mathbf{i}_r + F_\phi \mathbf{i}_\phi + F_\theta \mathbf{i}_\theta$
<b><math>F_n, F_s, F_v</math></b>	components of F along flight-path-coordinate directions, i.e., $\mathbf{F} = F_n \mathbf{e}_n + F_s \mathbf{e}_s + F_v \mathbf{e}_v$
<b>m</b>	mass of particle P
<b>(<math>\dot{\quad}</math>)</b>	denotes differentiation with respect to time.
<b>Notes:</b>	<ol style="list-style-type: none"> <li>1. Notation for nonrotating spherical coordinates is the same as above with the addition of a prime.</li> <li>2. <math>\mathbf{OP} \approx r \mathbf{i}_r</math></li> <li>3. <math>\mathbf{V} = V \mathbf{e}_v</math></li> </ol>

The equations of motion for a particle mass moving in the inertial frame fixed at the center of the earth are given below. These equations are derived from the basic vector equation for the motion,

$$\frac{\mathbf{F}}{m} = \frac{d\mathbf{V}'}{dt} = \frac{d\mathbf{V}}{dt} + (\boldsymbol{\Omega} \times \mathbf{V})$$

It is important to note that  $\mathbf{V}'$  is the inertial velocity measured with respect to nonrotating coordinates, and that  $\mathbf{V}$  is the relative velocity measured with respect to the rotating-coordinate system.

The equations of motion in nonrotating coordinates may be obtained by simply considering the angular velocity  $\boldsymbol{\Omega}$  to be zero in the equations for the rotating-coordinate system (in which case  $\mathbf{V} = \mathbf{V}'$ ).

The relation between spherical coordinates and flight-path coordinates is given by the following rotation of the base vectors  $\mathbf{i}_r, \mathbf{i}_\phi, \mathbf{i}_\theta$  at P. (refer to figure 2).

- a. Rotate  $\mathbf{i}_\theta$  about  $\mathbf{i}_r$  through angle  $90 - \delta$  to the flight plane determined by OP and V.
- b. Rotate in the flight plane through an angle  $\gamma$  such that the base vector  $\mathbf{i}_\theta$  now coincides with the velocity V. This base vector is then noted as  $\mathbf{e}_v$ .
- c. Rotate in roll about  $\mathbf{e}_v$  through an angle  $\eta$  to the final orientation of the flight-path base vectors  $\mathbf{e}_n, \mathbf{e}_s, \mathbf{e}_v$ .

## 1. ROTATING-EARTH SPHERICAL COORDINATES (REFERENCE 1)

$$\left. \begin{aligned}
 \frac{F_r}{m} &= \dot{V}_r - \frac{V_\phi^2 + (V_\theta + \Omega r \sin \phi)^2}{r} \\
 &= \ddot{r} - r(\dot{\phi})^2 - r(\dot{\theta} + \Omega)^2 \sin^2 \phi \\
 \frac{F_\phi}{m} &= \dot{V}_\phi + \frac{V_r V_\phi}{r} - \frac{(V_\theta + r \Omega \sin \phi)^2}{r \tan \phi} \\
 &= r\ddot{\phi} + 2\dot{r}\dot{\phi} - r(\dot{\theta} + \Omega)^2 \sin \phi \cos \phi \\
 \frac{F_\theta}{m} &= \dot{V}_\theta + \frac{(V_\theta + 2r\Omega \sin \phi)}{r} \left( \frac{V_\phi}{\tan \phi} + V_r \right) \\
 &= r\ddot{\theta} \sin \phi + 2r\dot{\phi}(\dot{\theta} + \Omega) \cos \phi + 2\dot{r}(\dot{\theta} + \Omega) \sin \phi
 \end{aligned} \right\} \quad (3)$$

## 2. ROTATING-EARTH FLIGHT-PATH COORDINATES

$$\left. \begin{aligned}
 \frac{F_n}{m} &= \left[ V\dot{\gamma} - \frac{V^2}{r} \cos \gamma - r\Omega^2 \sin \phi (\cos \gamma \sin \phi + \sin \gamma \cos \delta \cos \phi) \right. \\
 &\quad \left. - 2\Omega V \sin \delta \sin \phi \right] \cos \eta + \left[ V\dot{\delta} \cos \gamma - \frac{V^2}{r \sin \phi} \cos^2 \gamma \sin \delta \cos \phi \right. \\
 &\quad \left. - r\Omega^2 \sin \delta \sin \phi \cos \phi - 2\Omega V (\cos \gamma \cos \phi - \sin \gamma \cos \delta \sin \phi) \right] \sin \eta \\
 \frac{F_s}{m} &= \left[ V\dot{\delta} \cos \gamma - r\Omega^2 \sin \delta \sin \phi \cos \phi + 2\Omega V (\sin \gamma \cos \delta \sin \phi \right. \\
 &\quad \left. - \cos \gamma \cos \phi) - \frac{V^2}{r \sin \phi} \cos^2 \gamma \sin \delta \cos \phi \right] \cos \eta \\
 &\quad + \left[ \frac{V^2}{r} \cos \gamma - V\dot{\gamma} + 2\Omega V \sin \delta \sin \phi \right. \\
 &\quad \left. + r\Omega^2 \sin \phi (\cos \gamma \sin \phi + \sin \gamma \cos \delta \cos \phi) \right] \sin \eta \\
 \frac{F_v}{m} &= \left[ \dot{V} + r\Omega^2 \sin \phi (\cos \gamma \cos \delta \cos \phi - \sin \gamma \sin \phi) \right]
 \end{aligned} \right\} \quad (4)$$

Note: The equation for  $F_s$  (side force) may be solved for the roll angle  $\eta$  such that  $F_s = 0$ . The equations then become the equations for motion in coordinates similar to symmetric wind axes. The angle  $\eta$  is then the bank angle (in aircraft terminology) required for flight with zero sideslip.

## 3. NONROTATING-EARTH SPHERICAL COORDINATES

$$\left. \begin{aligned}
 \frac{F_r}{m} &= \dot{V}_r - \frac{(V'^2_\phi + V'^2_{\theta'})}{r} \\
 &= \ddot{r} - r(\dot{\phi})^2 - r(\dot{\theta}')^2 \sin^2 \phi \\
 \frac{F_\phi}{m} &= \dot{V}'_\phi + \frac{V'_r V'_\phi}{r} - \frac{V'^2_{\theta'}}{r \tan \phi} \\
 &= r\ddot{\phi} + 2\dot{r}\dot{\phi} - r(\dot{\theta}')^2 \sin \phi \cos \phi \\
 \frac{F_{\theta'}}{m} &= \dot{V}'_{\theta'} + \frac{V'_{\theta'} V'_r}{r} + \frac{V'_\phi V'_{\theta'}}{r \tan \phi} \\
 &= r\ddot{\theta}' \sin \phi + 2r\dot{\phi}\dot{\theta}' \cos \phi + 2\dot{r}\dot{\theta}' \sin \phi
 \end{aligned} \right\} \quad (5)$$

## 4. NONROTATING-EARTH FLIGHT-PATH COORDINATES

$$\left. \begin{aligned}
 \frac{F_{n'}}{m} &= \left[ V' \dot{\gamma}' - \frac{V'^2}{r} \cos \gamma' \right] \cos \eta' + \left[ V' \delta' \cos \gamma' - \frac{V'^2}{r \sin \phi} \cos^2 \gamma' \sin \delta' \cos \phi \right] \sin \eta' \\
 \frac{F_{s'}}{m} &= \left[ V' \dot{\delta}' \cos \gamma' - \frac{V'^2}{r \sin \phi} \cos^2 \gamma' \sin \delta' \cos \phi \right] \cos \eta' \\
 &\quad + \left[ \frac{V'^2}{r} \cos \gamma' - V' \dot{\gamma}' \right] \sin \eta' \\
 \frac{F_{v'}}{m} &= \dot{V}'
 \end{aligned} \right\} \quad (6)$$

### CYLINDRICAL-POLAR COORDINATE SYSTEM

Cylindrical coordinates have limited applications in particle-motion analysis. They are however conveniently used in many problems of planar motion where perturbations perpendicular to the fundamental plane are considered.

The general cylindrical-coordinate system is defined and illustrated in figure 3. Two-dimensional polar coordinates are a special case of cylindrical coordinates where the z-coordinate is held constant.

#### Description of Coordinate System

Origin of cylindrical coordinates  $r, \theta, z$ : arbitrary.

Fundamental plane: the reference plane normal to the polar (Z) axis.

Reference direction in the fundamental plane: arbitrary.

Polar (Z) axis positive direction and rotation in the fundamental plane: right-hand system.

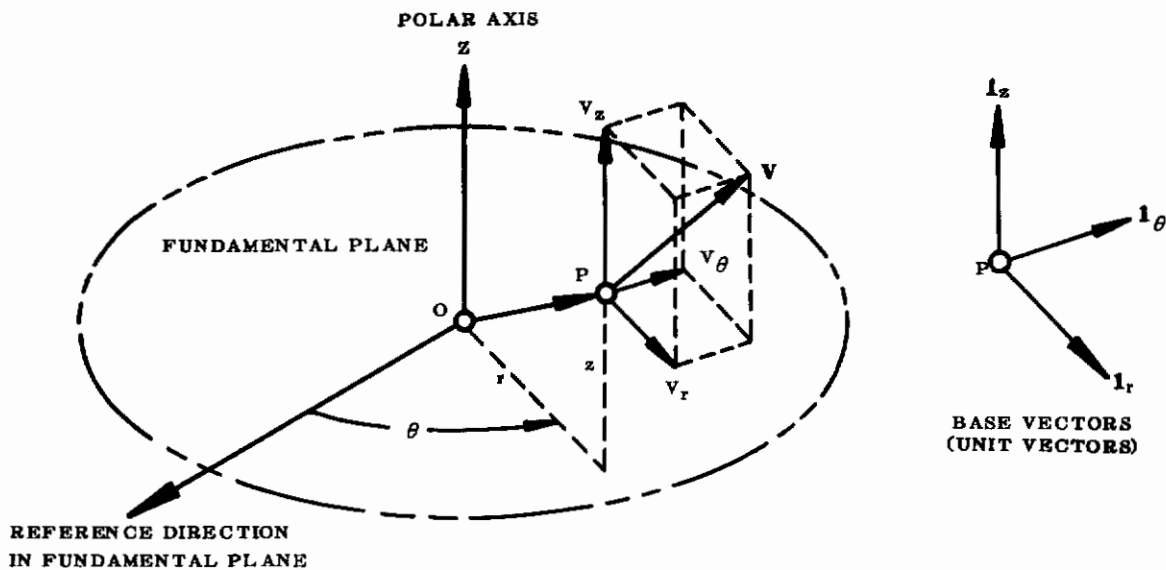

FIGURE 3 CYLINDRICAL-COORDINATE SYSTEM

## NOTATION

<b>O</b>	origin of coordinate system
<b>P</b>	denotes particle under consideration
<b>OP</b>	position vector of P (cylindrical coordinates $r, \theta, z$ )
<b>r</b>	radial distance of P from polar axis
<b><math>\theta</math></b>	angular displacement of P about polar axis from reference direction
<b>z</b>	displacement of P from the fundamental plane
<b><math>\mathbf{l}_r, \mathbf{l}_\theta, \mathbf{l}_z</math></b>	orthonormal base vectors at P along cylindrical-coordinate directions
<b>V</b>	velocity vector of P with respect to coordinate-axis system
<b><math>V_r, V_\theta, V_z</math></b>	components of velocity <b>V</b> along cylindrical-coordinate directions, i.e., $\mathbf{V} = V_r \mathbf{l}_r + V_\theta \mathbf{l}_\theta + V_z \mathbf{l}_z$
<b>F</b>	real force vector applied at P
<b><math>F_r, F_\theta, F_z</math></b>	components of <b>F</b> along cylindrical-coordinate directions, i.e., $\mathbf{F} = F_r \mathbf{l}_r + F_\theta \mathbf{l}_\theta + F_z \mathbf{l}_z$
<b>m</b>	mass of particle P
<b>(<math>\dot{\quad}</math>)</b>	denotes differentiation with respect to time
Note:	<b>OP</b> = $r \mathbf{l}_r + z \mathbf{l}_z$

For a particle moving in an inertial frame the equations of motion expressed in cylindrical coordinates are as follows:

$$\left. \begin{aligned} \frac{F_r}{m} &= \dot{V}_r - \frac{V_\theta^2}{r} = \ddot{r} - r(\dot{\theta})^2 \\ \frac{F_\theta}{m} &= \dot{V}_\theta + \frac{V_r V_\theta}{r} = r\ddot{\theta} + 2\dot{r}\dot{\theta} \\ \frac{F_z}{m} &= \dot{V}_z = \ddot{z} \end{aligned} \right\} \quad (7)$$

As was noted previously, the first and second equations above may be used for planar motion ( $z = \text{constant}$ ).

## RIGID-BODY MOTION

The coordinate systems and equations generally used in the analysis of the motion of a rigid body are presented in the Sections that follow. The preceding Sections have considered the motion of a point mass in several coordinate systems where position coordinates, as functions of time, are sufficient to describe the motions. For the more nearly complete case of rigid-body motion, it is necessary to consider the rotational motion of the body. In most cases, it is convenient to refer translation and rotation to the body center of gravity. This reference center is used in the cases that follow, unless specifically noted otherwise. The notation and coordinates used are consistent, insofar as possible, with the reference literature and current usage.

This Section describes various coordinate systems and gives equations of motion for a rigid body moving with respect to a flat, nonrotating reference frame. The origin of each coordinate system is located at the vehicle center of gravity. These conditions are those most commonly used in analysis of aircraft motion.

The general notation and terminology of established aircraft usage are used in this Section. A basic notation is established without subscripts. Various specialized axes systems and corresponding equations are denoted by subscripts added to the basic notation.

Limiting the reference frame to a rectangular, nonrotating system eliminates consideration of Coriolis-type forces in the equations of this Section.

\*In this report the terms center of gravity and center of mass are used interchangeably. The distinction is unimportant for applications.



All axis systems in this Section are right-hand and orthogonal.

A general notation for the force, velocity, and inertia terms used in the equations for motion of a rigid body are given below. These items refer to a rectangular-coordinate system having axes designated by X, Y, and Z, respectively. The origin of the coordinate system is at the center of gravity of the vehicle. The symbols below are used as listed for vehicle body axes and with subscripts for special axis systems.

## NOTATION

<b>i, j, k</b>	orthonormal base (unit) vectors along X, Y, and Z coordinate axes, respectively
<b>F</b>	external force vector applied at vehicle center of gravity; includes aerodynamic, thrust, and gravity forces
<b>F<sub>x</sub>, F<sub>y</sub>, F<sub>z</sub></b>	external force vector components along coordinate axes, i.e., $F = F_x i + F_y j + F_z k$
<b>G</b>	external moment vector applied at vehicle center of gravity
<b>G<sub>x</sub>, G<sub>y</sub>, G<sub>z</sub></b>	external moment vector components along coordinate axes, i.e., $G = G_x i + G_y j + G_z k$
<b>V</b>	total velocity vector of vehicle center of gravity (translation of origin with respect to a remote fixed point)
<b>U, V, W</b>	total velocity vector components along coordinate axes, i.e., $V = U i + V j + W k$
<b><math>\omega</math></b>	total angular-velocity vector of vehicle about its center of gravity
<b>P, Q, R</b>	angular-velocity vector components along coordinate axes, i.e., $\omega = P i + Q j + R k$ (Note: P is the angular velocity of rotation about the X-axis according to the right-hand rule of vector representation for moments and angular velocity.)
<b>mg</b>	gravity or weight vector of the vehicle
<b>I<sub>x</sub>, I<sub>y</sub>, I<sub>z</sub></b>	mass moments of inertia of the body about the X, Y, and Z coordinate axes, respectively
<b>I<sub>yz</sub>, I<sub>xz</sub>, I<sub>xy</sub></b>	mass products of inertia of the body with reference to the X, Y, and Z coordinate axes, respectively

Subscripts used with the above symbols denote axis systems as follows:

Subscript	Coordinate Axes System
e	earth axes
s	stability axes
p	principal axes
w	wind axes
wt	wind-tunnel axes

Various axis systems used frequently in the analysis of vehicle motion are described and sketched in the pages that follow. All of the coordinate systems presented are right-hand orthogonal systems with the origin located at the vehicle center of gravity.

Each axis system is defined and illustrated in vehicle notation, and terminology is outlined in reference 3. Special notation is defined as required and equations of motion are listed for the axis systems commonly used in stability and control analyses.

## EARTH AXES

Earth axes are used primarily as a reference system for the gravity vector, altitude, horizontal distance, and vehicle orientation. Fixed earth axes provide a reference for reckoning the flight path, altitude, and horizontal distance. Earth axes moving with the aircraft are sufficient to define the gravity vector and orientation of the vehicle. Both fixed and moving axes are illustrated below with the preferred sequence of rotation to define the orientation angles. (See reference 4).

### Description of Coordinate System

Origin location: arbitrary for fixed earth axes. The origin of moving earth axes is usually placed at the vehicle center of gravity.

# Contraails

$Z_e$ -axis: along the gravity vector  $mg$ . Thus  $Z_e$  is positive downward, i.e., toward the center of the earth.

Orientation of the  $X_e$ -axis: may be fixed arbitrarily. Fixed earth axes often have  $X_e$  directed toward the North polar axis. In moving earth axes the  $X_e$ -axis may be directed along the vehicle's initial azimuth heading.

$Y_e$ -axis: oriented to form a right-hand orthogonal axes system.

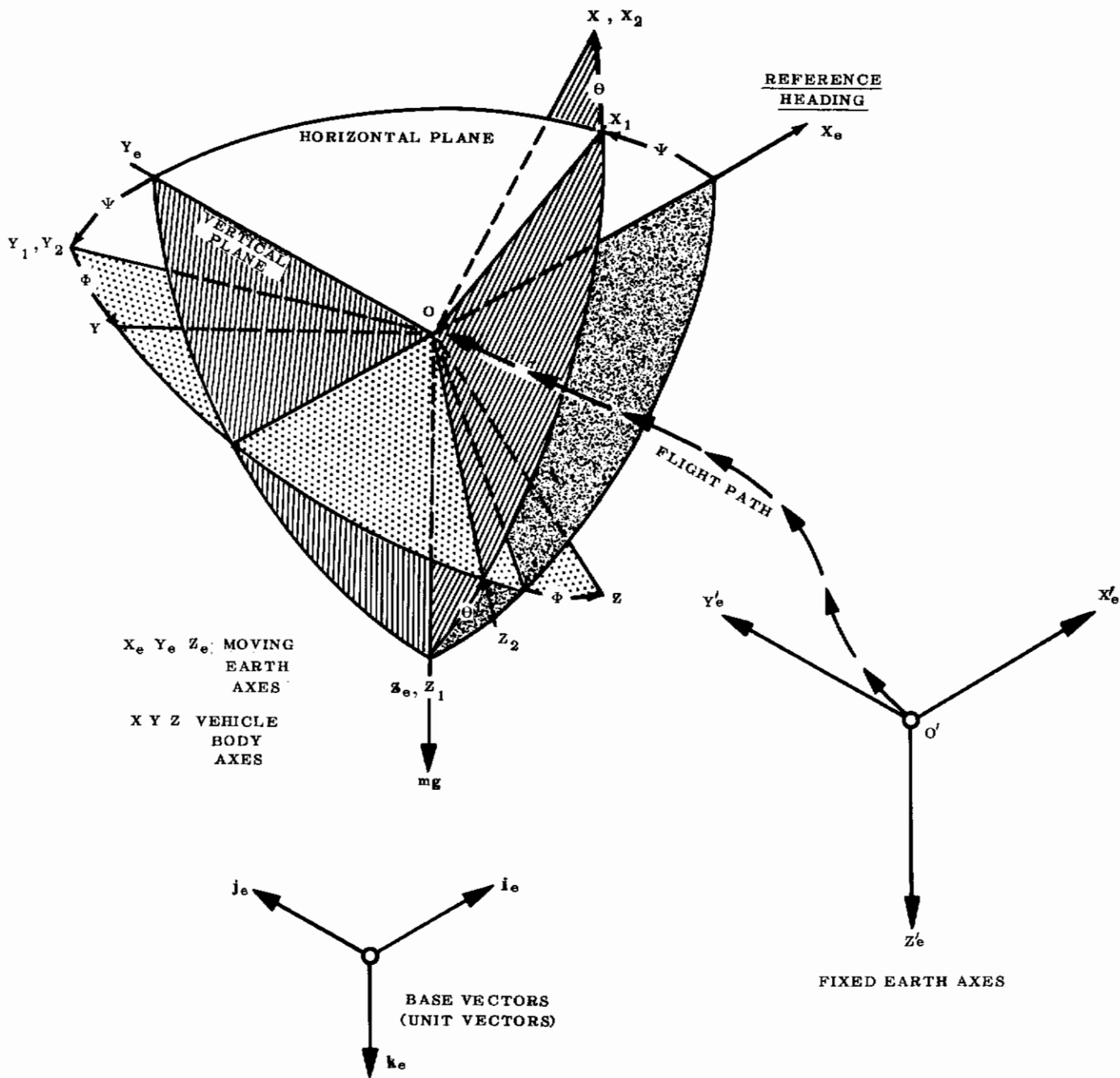

FIGURE 4 RELATIONSHIPS BETWEEN MOVING AND FIXED EARTH AXES, AND VEHICLE BODY AXES

The axes in figure 4 are defined as follows:

$X'_e, Y'_e, Z'_e$	fixed earth axes
$X_e, Y_e, Z_e$	moving earth axes parallel to fixed earth axes
$X_1, Y_1, Z_1$	intermediate axes used in defining orientation of vehicle
$X_2, Y_2, Z_2$	intermediate axes
$X, Y, Z$	vehicle body axes

The sequence of rotations defining the orientation angles of the body axes with respect to moving earth axes is as follows:

Rotate moving earth axes  $X_e, Y_e, Z_e$  through azimuth angle  $\psi$  about  $Z_e$ -axis to intermediate axes  $X_1, Y_1, Z_1$ .

Rotate axes  $X_1, Y_1, Z_1$  through elevation angle  $\theta$  about  $Y_1$ -axis to intermediate axes  $X_2, Y_2, Z_2$ .

Rotate axes  $X_2, Y_2, Z_2$  through bank angle  $\phi$  about  $X_2$ -axis to vehicle body axes  $X, Y, Z$ .

With the above rotation sequence the body-axes orientation angles may be defined in the following terms:

- $\psi$  Azimuth or yaw angle of body axes from reference direction of earth axes.
- $\theta$  elevation or pitch angle of body X-axis from the horizontal or  $X_e Y_e$ -plane.
- $\phi$  bank or roll angle of the body Y-axis about the body X-axis from the  $X_e Y_e$ -plane.

Note: The angles  $\psi$  and  $\theta$  are not necessarily the same as the flight-path heading and the flight-path angle, respectively.

## BODY AXES

The body axis system is the most general kind of axis system in which the axes are fixed to a rigid body. The use of axes fixed to the vehicle insures that the inertia terms in the equations of motion are constant and that aerodynamic forces and moments depend only upon the relative-velocity orientation angles  $\alpha$  and  $\beta$ . The orientation of body axis with respect to earth axis is defined in the preceding paragraph.

The general body axis system is defined and illustrated below. Special body axis systems, namely, the stability axis system and the principal axis system, are given on pages 13 and 14, respectively, of this Section.

### Description of Coordinate System

Origin: vehicle center of gravity.

Reference plane: XZ, usually a plane of symmetry.

Positive X-axis: forward along a reference line fixed to the vehicle.

Positive Z-axis: toward bottom of vehicle.

Positive rotation: about Y-axis from Z to X, i.e., right-hand system.

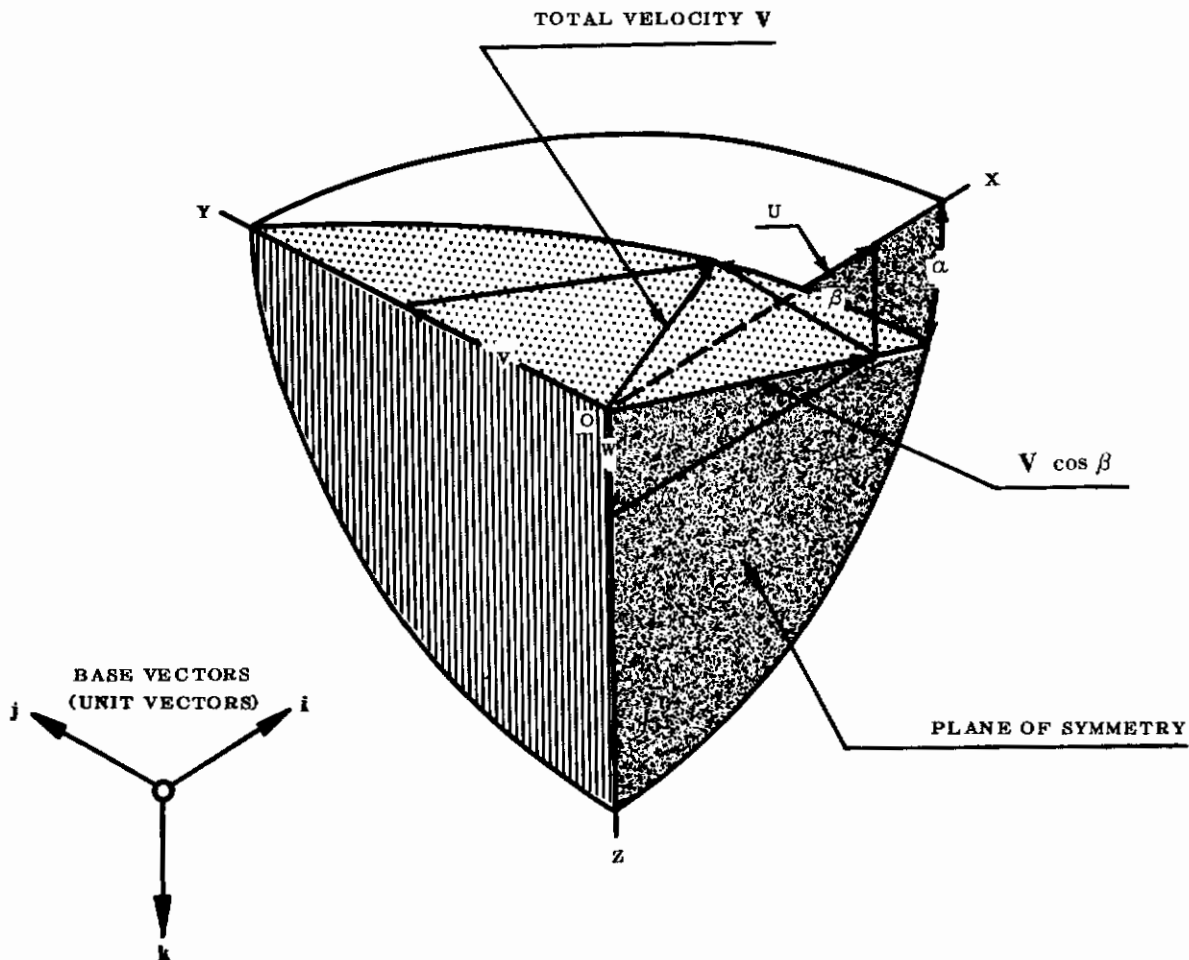

FIGURE 5 VEHICLE BODY AXES

The angles  $\alpha$  and  $\beta$  in figure 5 define the orientation of the velocity vector  $V$  with respect to the body axes  $X$ ,  $Y$ , and  $Z$ . The angle of attack  $\alpha$  and the angle of sideslip  $\beta$  are shown in the preferred yaw-pitch rotation sequence. (See page 41.)

Complete equations of motion referred to body axes are given below. The general notation defined on page 9 is used. These equations are applicable to any rigid body, since there are no simplifying conditions of symmetry used.

$$\left. \begin{aligned} F_x &= m (\dot{U} - R V + Q W) \\ F_y &= m (\dot{V} - P W + R U) \\ F_z &= m (\dot{W} - Q U + P V) \end{aligned} \right\} \quad (8)$$

$$\left. \begin{aligned} G_x &= \dot{P} I_x - \dot{Q} I_{xy} - \dot{R} I_{xz} - Q R (I_z - I_y) - P Q I_{xz} - (Q^2 - R^2) I_{yz} + P R I_{xy} \\ G_y &= + \dot{Q} I_y - \dot{R} I_{yz} - \dot{P} I_{xy} + P R (I_x - I_z) - Q R I_{xy} - (R^2 - P^2) I_{zx} + Q P I_{zy} \\ G_z &= + \dot{R} I_z - \dot{P} I_{xz} - \dot{Q} I_{yz} - P Q (I_y - I_x) - R P I_{yz} - (P^2 - Q^2) I_{xy} + R Q I_{zx} \end{aligned} \right\} \quad (9)$$

Notes: 1. In most instances a vehicle has a plane of symmetry, the  $XZ$ -plane. The product-of-inertia terms  $I_{xy}$  and  $I_{yz}$  are zero with this symmetry, and the equations may be simplified accordingly.

2. Gyroscopic terms resulting from rotating masses in the vehicle are not included.

## STABILITY AXES

Stability axes are specialized body axes (see preceding paragraph) in which the orientation of the "body axes" is determined by the initial flight condition. The  $X_s$ -axis is selected to be coincident with the velocity vector  $V_0$  at the start of the motion. Consequently, the moment-of-inertia and product-of-inertia terms vary for each initial flight condition. However, they are then constant in the equations of motion.

The use of stability axes is limited to symmetric initial flight conditions and small-disturbance motions

### Description of Coordinate System

Origin: vehicle center of gravity.

Reference plane:  $X_s Z_s$ , a plane of symmetry.

Positive  $X_s$ -axis: coincident with velocity vector at start of motion.

Positive  $Z_s$ -axis: toward bottom of vehicle.

Positive rotation: about  $Y_s$ -axis from  $Z_s$  to  $X_s$ , i.e., right-hand system.

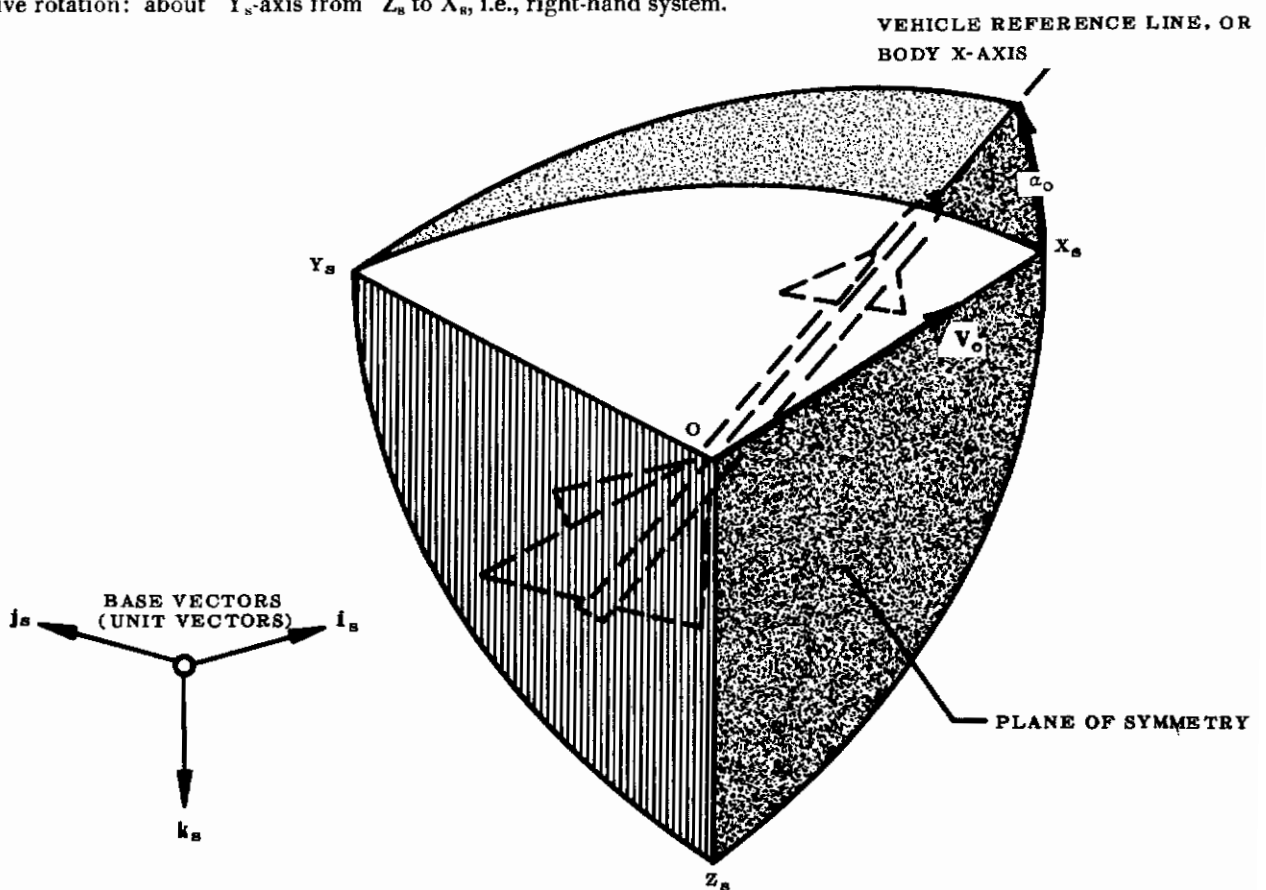

FIGURE 6 STABILITY AXES

The initial angle of attack  $\alpha_0$  is the angle between the body X-axis and the steady relative velocity vector  $V_0$  at the start of motion.

### Equations of Motion

The equations of motion referred to the stability axes of a vehicle symmetric about the XZ-plane are given below. Symbols are as defined on page 9.

$$\left. \begin{aligned} F_{x_s} &= m (\dot{U}_s + Q_s W_s - R_s V_s) \\ F_{y_s} &= m (\dot{V}_s + R_s U_s - P_s W_s) \\ F_{z_s} &= m (\dot{W}_s - Q_s U_s + P_s V_s) \end{aligned} \right\} \quad (10)$$

$$\left. \begin{aligned} G_{x_s} &= \dot{P}_s I_{x_s} - \dot{R}_s I_{xz_s} - Q_s R_s (I_{y_s} - I_{z_s}) - P_s Q_s I_{xz_s} \\ G_{y_s} &= \dot{Q}_s I_{y_s} - R_s P_s (I_{z_s} - I_{x_s}) - (R_s^2 - P_s^2) I_{xz_s} \\ G_{z_s} &= + \dot{R}_s I_{z_s} - \dot{P}_s I_{xz_s} - P_s Q_s (I_{x_s} - I_{y_s}) + Q_s R_s I_{xz_s} \end{aligned} \right\} \quad (11)$$

## PRINCIPAL AXES

A special set of body axes (see preceding paragraph) aligned with the principal axes of the vehicle and therefore called principal axes is used for certain applications. The convenience of principal axes results from the fact that all of the product-of-inertia terms are reduced to zero. The equations of motion are thus greatly simplified.

### Description of Coordinate System

Origin: vehicle center of gravity.

Reference plane:  $X_p Z_p$ , a plane of symmetry.

Positive  $X_p$ -axis: forward along principal axis nearest the direction of motion.

Positive  $Z_p$ -axis: in plane of symmetry, toward bottom of vehicle, normal to  $X_p$ .

Positive rotation about  $Y_p$ -axis: from  $Z_p$  to  $X_p$ , i.e., right-hand system.

The angle  $\epsilon$  denotes the angle between the principal axis  $X_p$  and the body X-axis.

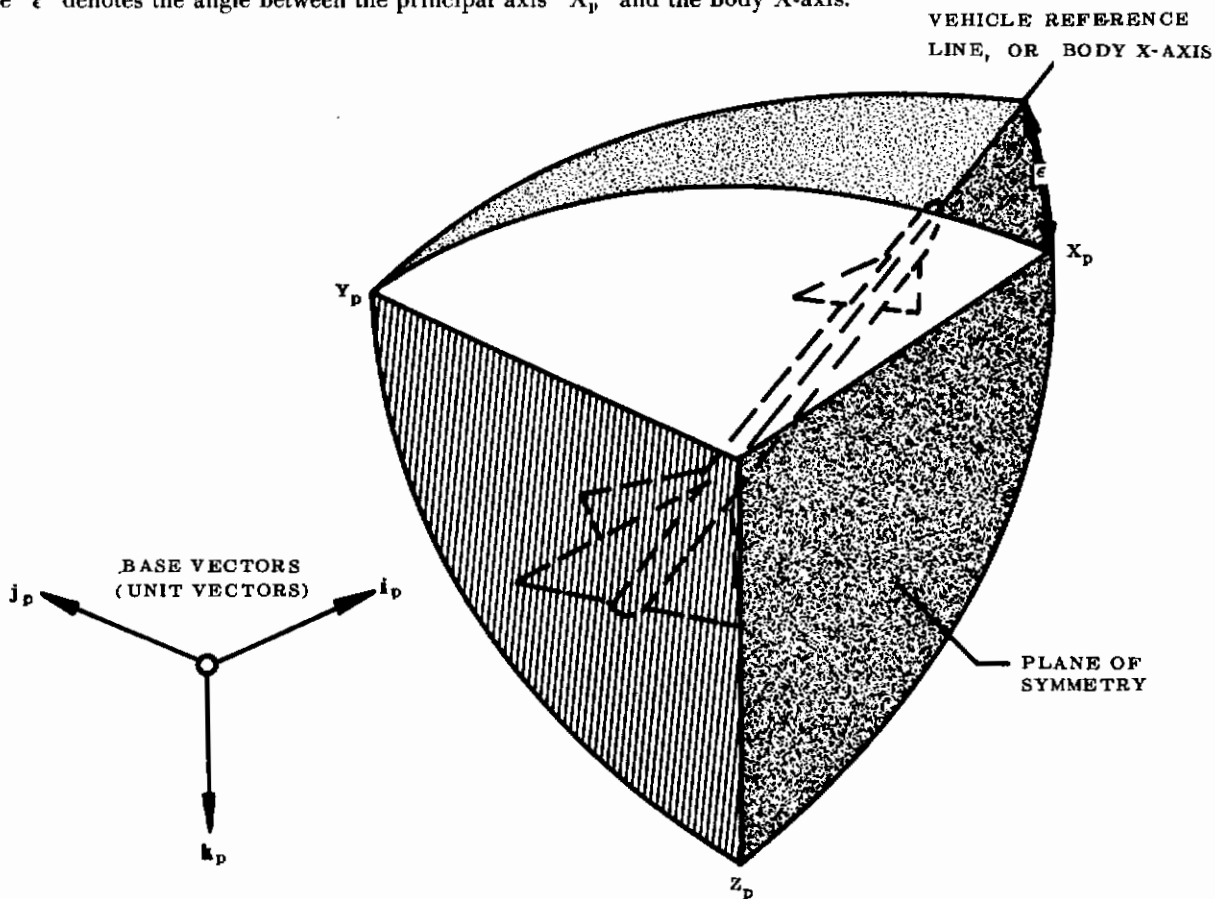

FIGURE 7 PRINCIPAL AXES

The equations of motion referred to the principal axes are listed below. Symbols are defined on page 9.

$$\left. \begin{aligned} F_{x_p} &= m (\dot{U}_p - R_p V_p + Q_p W_p) \\ F_{y_p} &= m (\dot{V}_p - P_p W_p + R_p U_p) \\ F_{z_p} &= m (\dot{W}_p - Q_p U_p + P_p V_p) \end{aligned} \right\} \quad (12)$$

$$\left. \begin{aligned} G_{x_p} &= \dot{P}_p I_{x_p} - Q_p R_p (I_{y_p} - I_{z_p}) \\ G_{y_p} &= \dot{Q}_p I_{y_p} - R_p P_p (I_{z_p} - I_{x_p}) \\ G_{z_p} &= \dot{R}_p I_{z_p} - P_p Q_p (I_{x_p} - I_{y_p}) \end{aligned} \right\} \quad (13)$$

### GENERAL WIND AXES

General wind axes use the vehicle translational velocity as the reference for the axis system. Wind axes are thus oriented with respect to the flight path of the vehicle, i.e., with respect to the relative wind.

The relation between general wind axes and vehicle body axes defines the angle of attack  $\alpha$  and the sideslip angle  $\beta$ . These angles are convenient independent variables for use in the expression of aerodynamic force and moment coefficients.

Wind axes are not generally used in the analysis of the motion of a rigid body, because, as in the case of earth axes, the moment-of-inertia and product-of-inertia terms in the three rotational equations of motion vary with time, angle of attack, and sideslip angle.

The general wind-axis system is defined and illustrated below. A special case of symmetric wind axes follows on page 16.

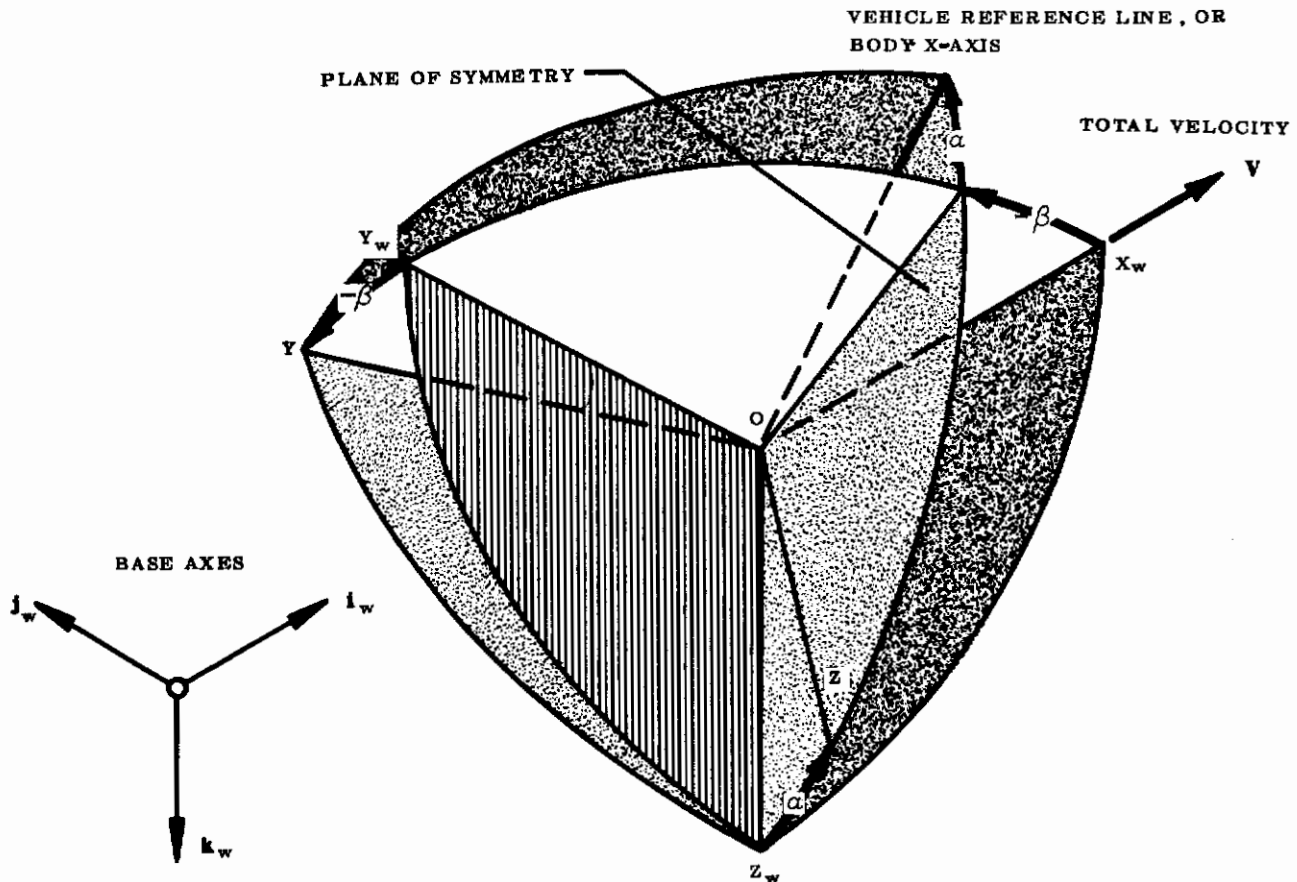

FIGURE 8 GENERAL WIND AXES

## Description of Coordinate System

Origin: vehicle center of gravity.

Reference plane:  $X_w Z_w$ -plane.

Positive  $X_w$ -axis: along the velocity vector  $V$ .

Positive  $Z_w$ -axis: in the vehicle plane of reference  $XZ$  and toward the bottom of the vehicle.

Positive rotation about  $Y_w$ -axis: from  $Z_w$  to  $X_w$ , i.e., right-hand system.

The angles  $\alpha$  and  $\beta$  in figure 8 are shown in the yaw-pitch rotation sequence. The orientation relations between the body axes and the general wind axes are given in Section 3.

The equations of motion of a rigid body referred to general wind axes are identical in form to the equations of motion referred to body axes. Thus the equations in general wind axes may be obtained from the equations given on page 12. The moment-of-inertia and product-of-inertia terms become very complex in the general wind axes system and thus practically preclude the use of these axes in the analysis of vehicle motion.

### SYMMETRIC WIND AXES

The symmetric case of the preceding general wind axes may be usefully applied in the analysis of symmetric vehicle motion, e.g., dive recovery. Symmetric wind axes are obtained from the general wind axes when the sideslip angle  $\beta$  is zero. Thus the preceding description and illustration for the general case may be used directly with  $\beta = 0$ .

The equations of motion for the symmetric, unbanked flight of a vehicle with a plane of symmetry are given below.

$$\left. \begin{aligned} F_{X_w} &= m \dot{U}_w \\ F_{Y_w} &= 0 \\ F_{Z_w} &= -m Q_w U_w \end{aligned} \right\} \quad (14)$$

$$\left. \begin{aligned} G_{X_w} &= 0 \\ G_{Y_w} &= \dot{Q}_w I_{Y_w} \\ G_{Z_w} &= 0 \end{aligned} \right\} \quad (15)$$

### WIND-TUNNEL STABILITY AXES

Wind-tunnel stability axes are used as a reference system for measuring and reducing aerodynamic data in wind-tunnel tests. This set of axes differs from the previous stability axes in that the  $Z_{wt}$ -axis is aligned normal to, and remains normal to, the relative wind, whereas the general stability axes are body axes determined by the initial flight condition.

Since it is not convenient to use wind-tunnel stability axes in analysis of the motion of a vehicle, the equations of motion are omitted for this case.

## Description of Coordinate System

Origin location: in the reference plane of the vehicle at the point corresponding to the vehicle center of gravity.

Reference plane: the  $X_{wt} Z_{wt}$  plane.

Positive  $Z_{wt}$ -axis: in the reference plane of the vehicle perpendicular to the relative wind  $V$ .

Positive  $X_{wt}$ -axis: toward the forward part of the vehicle, along the projection of the relative wind  $V$  upon the vehicle reference plane.

Positive  $Y_{wt}$ -axis: oriented to form a right-hand orthogonal axes system.



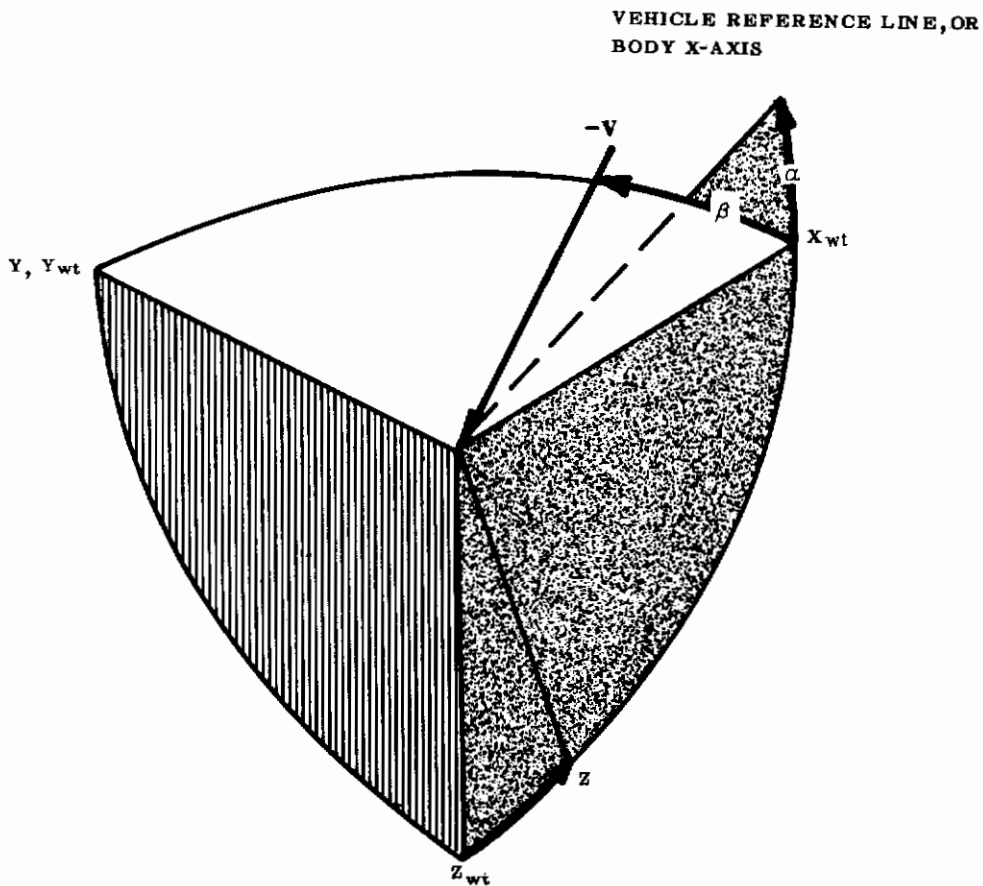

FIGURE 9 WIND-TUNNEL STABILITY AXES

In the above figure the angle of attack  $\alpha$  and the sideslip angle  $\beta$  give the orientation of the relative-velocity vector to the vehicle body axes. Wind-tunnel stability axes use the yaw-pitch rotation sequence (page 46).

## NONROLLING AXES

The problem of formulating equations of motion for a symmetric rolling body may be simplified by using a nonrolling axis system. Nonrolling axes are a special set of body axes having the Y-axis always horizontal and the XZ-plane always vertical. This axis system may be used even though the body rotates about the X-axis. It is necessary, however, that the inertia parameters and the aerodynamic forces, moments, and derivatives be constant with respect to the nonrolling reference frame. Thus the body must have rotational symmetry about the X-axis. Applications of nonrolling axes to the motion analyses of aircraft, projectiles, and missiles are given in reference 5.

## SECTION 3. COORDINATE -SYSTEM TRANSFORMATIONS

In vehicle-motion analysis it is frequently necessary or expedient to transform coordinates, vector components, inertia parameters, and stability derivatives from one coordinate system to another. The following section gives the relations most frequently used in such transformations.

Equations are used to express the transforming relations whenever these relations are simple and not often repeated. Matrix notation is used in the more complex transformations, and a tabular presentation is given when the forms of a transformation relation are similar for several cases.

### PARTICLE-MOTION TRANSFORMATIONS

The transformations between the coordinate systems useful in the analysis of particle motion are given in the pages that follow. Notation and definitions of terms are consistent with those used in the preceding sections.

#### RECTANGULAR COORDINATES

Cartesian or rectangular coordinates are perhaps the most commonly used coordinates. The following pages give relations for translation of the origin and the rotation of rectangular-coordinate systems about the origin. Composite changes involving translation and rotation of the coordinate axes may be accomplished by successive application of these two basic transformations.

The equations relating spherical coordinates to rectangular coordinates and the equations relating cylindrical coordinates to rectangular coordinates are also included in this section.

Symbols and notation are defined when first used or as required.

Translation of the origin in rectangular coordinates is illustrated in the figure below.

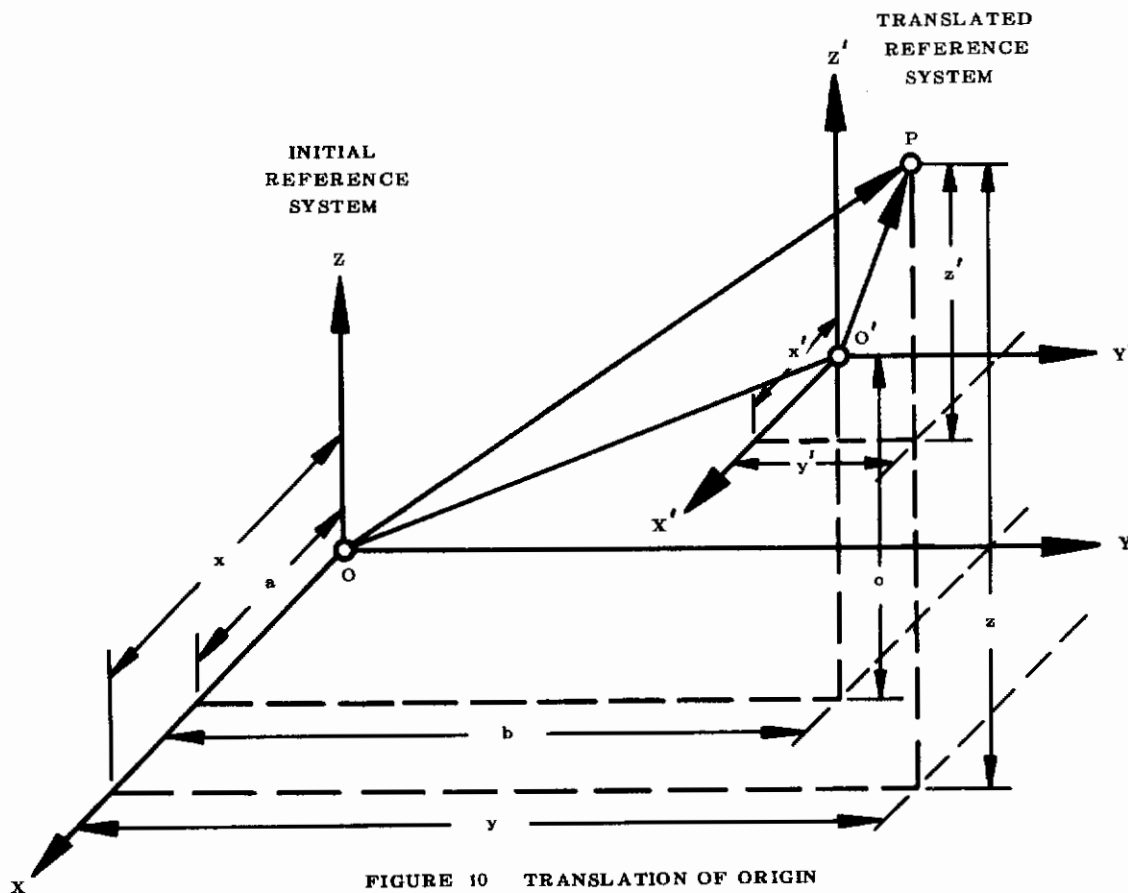

FIGURE 10 TRANSLATION OF ORIGIN

## NOTATION

- O origin of rectangular coordinate system with axes X, Y, and Z
- x, y, z position coordinates of point P
- x, y, z components of the vector OP
- a, b, c position coordinates of translated origin O' in initial coordinate reference system. (These coordinates are considered as constants.)
- ( )' denotes coordinates and quantities referred to the translated coordinate system

From figure 10 the relation between coordinates in the initial and in the translated coordinate system is

$$\begin{aligned}x' &= x - a \\y' &= y - b \\z' &= z - c\end{aligned}$$

Since there is no rotation of the coordinate axes with a pure translation, the components of a vector at P referred to the axes X, Y, and Z are identical to the components referred to the axes X', Y', and Z'. Consequently, components of vectors such as force and moment vectors are unchanged by a translation of the origin. Velocity- and acceleration-vector components are unchanged also, except when the translated axis system becomes a moving reference system.

Rotation of rectangular-coordinate axes about the origin is very often useful and sometimes quite necessary. A general rotation of an orthogonal-axes system may be accomplished by three successive planar rotations; hence a simple planar rotation is considered first and then extended to the general case. Also included in this section are the direction-cosine relations for defining a general rotation of rectangular-coordinate axes. The relations given in the following pages are developed in many standard mathematics and engineering texts, such as references 6, 7, and 8. The tabular presentation of the transformation relations is adapted from reference 9.

### 1. PLANAR ROTATION

The rotation given below corresponds to a rotation in the XY-plane about the Z-axis. The subscript 1 denotes the rotated axes and components in the coordinate system that has been rotated through an angle  $\psi$ .

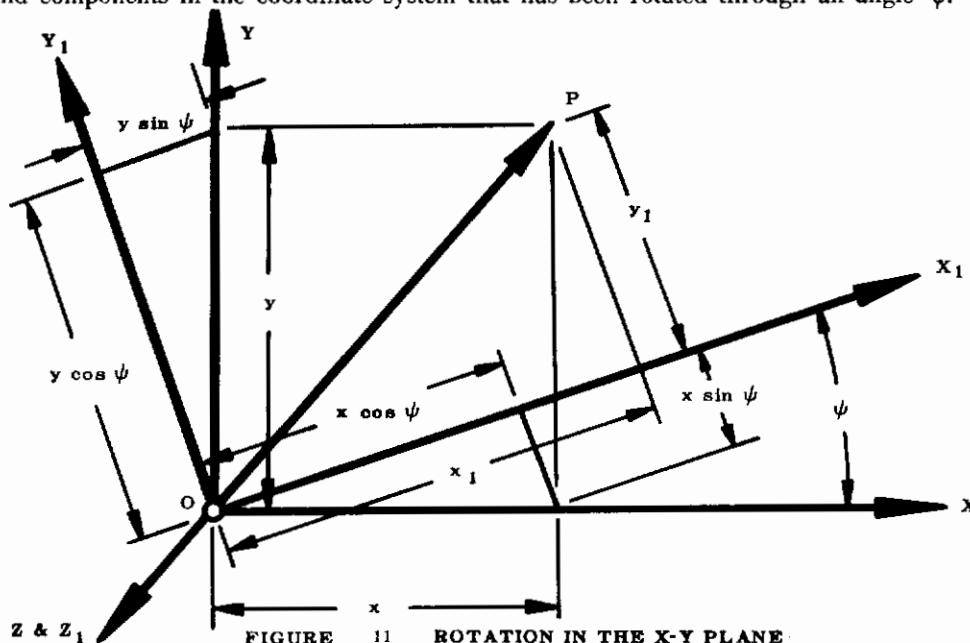

# Contrails

The components of the vector **OP** in the preceding figure are transformed from  $x$ ,  $y$ , and  $z$  to  $x_1$ ,  $y_1$ , and  $z_1$ , respectively, by the following equations:

$$\begin{aligned} x_1 &= x \cos \psi + y \sin \psi \\ y_1 &= -x \sin \psi + y \cos \psi \\ z_1 &= z \end{aligned}$$

These equations may conveniently be expressed in matrix form.

$$\begin{bmatrix} x_1 \\ y_1 \\ z_1 \end{bmatrix} = \begin{bmatrix} \cos \psi & \sin \psi & 0 \\ -\sin \psi & \cos \psi & 0 \\ 0 & 0 & 1 \end{bmatrix} \begin{bmatrix} x \\ y \\ z \end{bmatrix} = [\psi] \begin{bmatrix} x \\ y \\ z \end{bmatrix}$$

The components of any vector in the XY-plane may be transformed by the above relations.

Since the transformation matrix is orthogonal, the inverse transformation  $[\psi]^{-1}$  is given by the transpose of  $[\psi]$ . Since the transpose of a matrix is obtained by interchanging the rows and the columns, in this case the inverse transformation matrix  $[\psi]^{-1}$  is defined as

$$[\psi]^{-1} \equiv [\psi]' = \begin{bmatrix} \cos \psi & -\sin \psi & 0 \\ \sin \psi & \cos \psi & 0 \\ 0 & 0 & 1 \end{bmatrix}$$

whence

$$\begin{bmatrix} x \\ y \\ z \end{bmatrix} = [\psi]^{-1} \begin{bmatrix} x_1 \\ y_1 \\ z_1 \end{bmatrix}$$

Note that this procedure is equivalent to replacing the angle  $\psi$  by  $-\psi$  and interchanging the subscripted and unsubscripted components in the first form of the equations.

It is convenient to introduce a tabular presentation for the transformation matrix and its inverse. Table 1 gives the transformation matrix array with initial position coordinates at the head of each column and the rotated coordinates in front of each row. From this array the transformation and inverse-transformation equations are written by using the matrix elements as coefficients of the appropriate vector components in the transforming equations.

TABLE 1.  
VECTOR TRANSFORMATION MATRIX  
INITIAL AXES TO ROTATED AXES

		COMPONENTS IN INITIAL COORDINATE SYSTEM		
		X	Y	Z
COMPONENTS IN ROTATED COORD. SYSTEM	X <sub>1</sub>	cos $\psi$	sin $\psi$	0
	Y <sub>1</sub>	-sin $\psi$	cos $\psi$	0
	Z <sub>1</sub>	0	0	1

Direct transformation equations are obtained by summing horizontally along each row.

$$\begin{aligned} x_1 &= (\cos \psi) x + (\sin \psi) y + (0) z \\ y_1 &= (-\sin \psi) x + (\cos \psi) y + (0) z \\ z_1 &= (0) x + (0) y + (1) z \end{aligned}$$

Inverse transformation equations are obtained by summing vertically down each column.

$$x = (\cos \psi) x_1 + (-\sin \psi) y_1 + (0) z_1$$

$$y = (\sin \psi) x_1 + (\cos \psi) y_1 + (0) z_1$$

$$z = (0) x_1 + (0) y_1 + (1) z_1$$

## 2. GENERAL ROTATION

The general rotation of a rectangular axes system may be accomplished by successive planar rotations of the type described in the preceding paragraph. In making a general rotation, however, the sequence of rotation is important. The basic order of rotation is described and illustrated below. This sequence of rotation and the terminology have been used extensively in aircraft motion analysis (references 4 and 7).

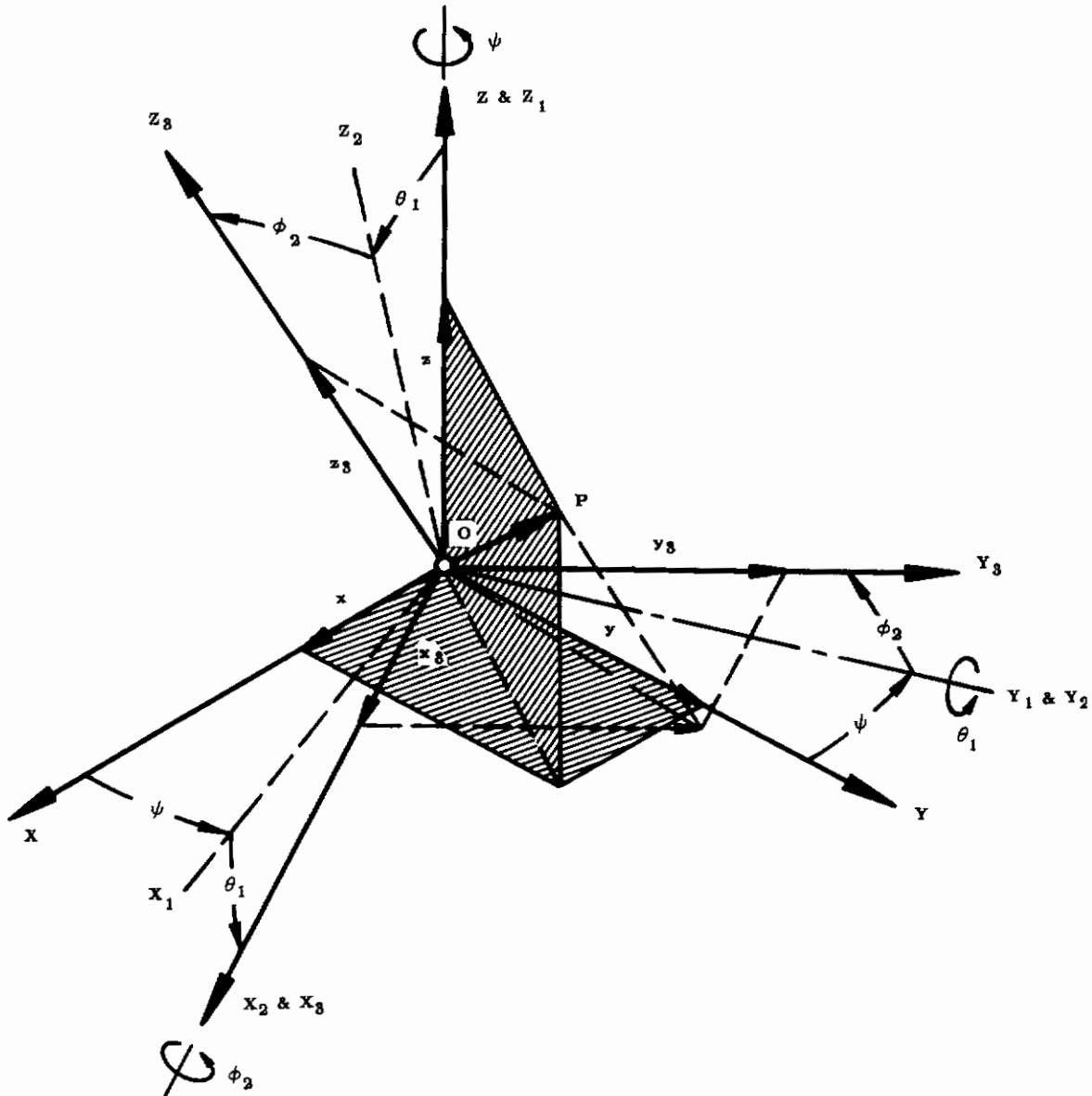

FIGURE 12 GENERAL ROTATION ABOUT ORIGIN — ORIENTATION-ANGLE DESCRIPTION OF ROTATION

The transformation matrices are given in tabular form for the basic sequences and for several other sequences of axis rotation. These transformations may be applied to position, velocity, force, moment, and acceleration vectors to obtain their components in the rotated-axes system. Both the direct- and inverse-transformation relations are obtained from the tabular presentation as shown in the sample problem.

In the preceding sketch the coordinate axes are designated by capital letters (X, Y, Z) and the position coordinates by lower case letters (x, y, z). The Greek symbols  $\phi$ ,  $\theta$ , and  $\psi$  are used to refer to angular rotation about the X-, Y-, and Z-axes, respectively. Subscripts refer to the various rotated-axes systems. Thus the subscript 3 denotes the final axes and coordinates. Similar subscripts are used with the rotation angles to indicate the reference axes for the particular angle. The basic order of rotation is

1. "Yaw" about Z-axis through the angle  $\psi$ .
2. "Pitch" about Y<sub>1</sub>-axis through the angle  $\theta_1$ .
3. "Roll" about X<sub>2</sub>-axis through the angle  $\phi_2$ .

General transformations for rotation of rectangular-coordinate systems are tabulated in table 2. Both direct and inverse transformations are given, as illustrated in the sample problems on this page. Also included in this table are the equations for the instantaneous angular velocities  $\dot{\phi}_3$ ,  $\dot{\theta}_3$ , and  $\dot{\psi}_3$  about the final coordinate axes in terms of the orientation angles and their rates of change.

The first case listed is the most commonly used order of rotation. Cases 1 and 2 may be considered as fundamental rotations. The remaining cases may be obtained from cyclic permutations of the initial coordinate and angle notation. It should be noted that changing the sequence of rotation changes the definition of the orientation angles. Consequently, angles with different subscripts are not interchangeable, i.e., generally  $\phi_1 \neq \phi_2 \neq \phi_3$ . Also, the orientation angle rates of change, i.e.,  $\dot{\psi}$ ,  $\dot{\theta}_1$ ,  $\dot{\phi}_2$ , are not orthogonal.

Use of table 2 is illustrated by the sample problems below.

### Example 1. Direct Transformation

Given: Velocity-vector components  $V_X$ ,  $V_Y$ ,  $V_Z$ .

Rotation order: yaw, pitch, roll ( $\psi$  to  $\theta_1$  to  $\phi_2$ , as in Case I of table 2).

Find: Velocity-vector component along Z<sub>3</sub>-axis ( $V_{Z_3}$ ).

Solution: Write equation for  $V_{Z_3}$  by summing terms along the Z<sub>3</sub>-row of the vector transformation matrix.

$$\begin{aligned} V_{Z_3} = & (\cos \phi_2 \sin \theta_1 \cos \psi + \sin \phi_2 \sin \psi) V_X \\ & + (\cos \phi_2 \sin \theta_1 \sin \psi - \sin \phi_2 \cos \psi) V_Y \\ & + (\cos \phi_2 \cos \theta_1) V_Z \end{aligned}$$

### Example 2. Inverse Transformation

Given: Acceleration vector components  $a_{X_3}$ ,  $a_{Y_3}$ ,  $a_{Z_3}$  along final coordinate axes.

Rotation order: yaw, pitch, roll ( $\psi$  to  $\theta_1$  to  $\phi_2$ , as in Case I of table 2)

Find: Acceleration vector component along X-axis ( $a_X$ ).

Solution: Write equation for  $a_X$  by summing terms down the x-column of the vector transformation matrix.

TABLE 2  
RECTANGULAR COORDINATE TRANSFORMATIONS  
ROTATION OF AXES ABOUT ORIGIN

		VECTOR TRANSFORMATION MATRIX			ANGULAR VELOCITY RELATIONS		
CASE 1		INITIAL VECTOR COMPONENTS			Direct — $\dot{\phi}_3 = \dot{\phi}_2 - \dot{\psi} \sin \theta_1$ $\dot{\theta}_3 = \dot{\theta}_1 \cos \phi_2 + \dot{\psi} \sin \phi_2 \cos \theta_1$ $\dot{\psi}_3 = -\dot{\theta}_1 \sin \phi_2 + \dot{\psi} \cos \phi_2 \cos \theta_1$ Inverse — $\dot{\psi} = \dot{\theta}_3 \sin \phi_2 \sec \theta_1 + \dot{\psi}_3 \cos \phi_2 \sec \theta_1$ $\dot{\theta}_1 = \dot{\theta}_3 \cos \phi_2 - \dot{\psi}_3 \sin \phi_2$ $\dot{\phi}_2 = \dot{\phi}_3 + \dot{\theta}_3 \sin \phi_2 \tan \theta_1 + \dot{\psi}_3 \cos \phi_2 \tan \theta_1$		
YAW		TRANSFORMED VECTOR COMPONENTS	X <sub>3</sub>	cos θ <sub>1</sub> cos ψ		cos θ <sub>1</sub> sin ψ	−sin θ <sub>1</sub>
PITCH			Y <sub>3</sub>	sin φ <sub>2</sub> sin θ <sub>1</sub> cos ψ −cos φ <sub>2</sub> sin ψ		sin φ <sub>2</sub> sin θ <sub>1</sub> sin ψ +cos φ <sub>2</sub> cos ψ	sin φ <sub>2</sub> cos θ <sub>1</sub>
ROLL			Z <sub>3</sub>	cos φ <sub>2</sub> sin θ <sub>1</sub> cos ψ +sin φ <sub>2</sub> sin ψ		cos φ <sub>2</sub> sin θ <sub>1</sub> sin ψ −sin φ <sub>2</sub> cos ψ	cos φ <sub>2</sub> cos θ <sub>1</sub>
CASE 2		INITIAL VECTOR COMPONENTS			Direct — $\dot{\phi}_3 = \dot{\phi}_1 \cos \theta_2 - \dot{\psi} \cos \phi_1 \sin \theta_2$ $\dot{\theta}_3 = \dot{\theta}_2 + \dot{\psi} \sin \phi_1$ $\dot{\psi}_3 = \dot{\phi}_1 \sin \theta_2 + \dot{\psi} \cos \phi_1 \cos \theta_2$ Inverse — $\dot{\psi} = -\dot{\theta}_3 \sec \phi_1 \sin \theta_2 + \dot{\psi}_3 \sec \phi_1 \cos \theta_2$ $\dot{\phi}_1 = \dot{\phi}_3 \cos \theta_2 + \dot{\psi}_3 \sin \theta_2$ $\dot{\theta}_2 = \dot{\theta}_3 \tan \phi_1 \sin \theta_2 + \dot{\psi}_3 - \dot{\psi}_3 \tan \phi_1 \cos \theta_2$		
YAW		TRANSFORMED VECTOR COMPONENTS	X <sub>3</sub>	cos θ <sub>2</sub> cos ψ		cos θ <sub>2</sub> sin ψ	−cos φ <sub>1</sub> sin θ <sub>2</sub>
ROLL			Y <sub>3</sub>	−cos φ <sub>1</sub> sin ψ		cos φ <sub>1</sub> cos ψ	sin φ <sub>1</sub>
PITCH			Z <sub>3</sub>	sin θ <sub>2</sub> cos ψ		sin θ <sub>2</sub> sin ψ	cos φ <sub>1</sub> cos θ <sub>2</sub>
CASE 3		INITIAL VECTOR COMPONENTS			Direct — $\dot{\phi}_3 = \dot{\phi}_1 \cos \psi_2 + \dot{\theta} \cos \phi_1 \sin \psi_2$ $\dot{\theta}_3 = -\dot{\phi}_1 \sin \psi_2 + \dot{\theta} \cos \phi_1 \cos \psi_2$ $\dot{\psi}_3 = -\dot{\theta} \sin \phi_1 + \dot{\psi}_2$ Inverse — $\dot{\theta} = \dot{\phi}_3 \sec \phi_1 \sin \psi_2 + \dot{\theta}_3 \sec \phi_1 \cos \psi_2$ $\dot{\phi}_1 = \dot{\phi}_3 \cos \psi_2 - \dot{\theta}_3 \sin \psi_2$ $\dot{\psi}_2 = \dot{\phi}_3 \tan \phi_1 \sin \psi_2 + \dot{\theta}_3 \tan \phi_1 \cos \psi_2 + \dot{\psi}_3$		
PITCH		TRANSFORMED VECTOR COMPONENTS	X <sub>3</sub>	cos θ cos ψ <sub>2</sub>		cos φ <sub>1</sub> sin ψ <sub>2</sub>	−sin θ cos ψ <sub>2</sub>
ROLL			Y <sub>3</sub>	−cos θ sin ψ <sub>2</sub>		cos φ <sub>1</sub> cos ψ <sub>2</sub>	sin θ sin ψ <sub>2</sub>
YAW			Z <sub>3</sub>	cos φ <sub>1</sub> sin θ		−sin φ <sub>1</sub>	cos φ <sub>1</sub> cos θ
CASE 4		INITIAL VECTOR COMPONENTS			Direct — $\dot{\phi}_3 = \dot{\phi}_2 + \dot{\theta} \sin \psi_1$ $\dot{\theta}_3 = \dot{\theta} \cos \phi_2 \cos \psi_1 + \dot{\psi}_1 \sin \phi_2$ $\dot{\psi}_3 = -\dot{\theta} \sin \phi_2 \cos \psi_1 + \dot{\psi}_1 \cos \phi_2$ Inverse — $\dot{\theta} = \dot{\theta}_3 \cos \phi_2 \sec \psi_1 - \dot{\psi}_3 \sin \phi_2 \sec \psi_1$ $\dot{\psi}_1 = \dot{\theta}_3 \sin \phi_2 + \dot{\psi}_3 \cos \phi_2$ $\dot{\phi}_2 = \dot{\phi}_3 - \dot{\theta}_3 \cos \phi_2 \tan \psi_1 + \dot{\psi}_3 \sin \phi_2 \tan \psi_1$		
PITCH		TRANSFORMED VECTOR COMPONENTS	X <sub>3</sub>	cos θ cos ψ <sub>1</sub>		sin ψ <sub>1</sub>	−sin θ cos ψ <sub>1</sub>
YAW			Y <sub>3</sub>	−cos φ <sub>2</sub> cos θ sin ψ <sub>1</sub>		cos φ <sub>2</sub> cos ψ <sub>1</sub>	cos φ <sub>2</sub> sin θ sin ψ <sub>1</sub>
ROLL			Z <sub>3</sub>	sin φ <sub>2</sub> cos θ sin ψ <sub>1</sub>		−sin φ <sub>2</sub> cos ψ <sub>1</sub>	−sin φ <sub>2</sub> sin θ sin ψ <sub>1</sub>
CASE 5		INITIAL VECTOR COMPONENTS			Direct — $\dot{\phi}_3 = \dot{\phi} \cos \theta_2 \cos \psi_1 - \dot{\psi}_1 \sin \theta_2$ $\dot{\theta}_3 = -\dot{\phi} \sin \psi_1 + \dot{\theta}_2$ $\dot{\psi}_3 = \dot{\phi} \sin \theta_2 \cos \psi_1 + \dot{\psi}_1 \cos \theta_2$ Inverse — $\dot{\phi} = \dot{\phi}_3 \cos \theta_2 \sec \psi_1 + \dot{\psi}_3 \sin \theta_2 \sec \psi_1$ $\dot{\psi}_1 = -\dot{\phi}_3 \sin \theta_2 + \dot{\psi}_3 \cos \theta_2$ $\dot{\theta}_2 = \dot{\phi}_3 \cos \theta_2 \tan \psi_1 + \dot{\theta}_3 + \dot{\psi}_3 \sin \theta_2 \tan \psi_1$		
ROLL		TRANSFORMED VECTOR COMPONENTS	X <sub>3</sub>	cos θ <sub>2</sub> cos ψ <sub>1</sub>		cos φ cos θ <sub>2</sub> sin ψ <sub>1</sub>	sin φ cos θ <sub>2</sub> sin ψ <sub>1</sub>
YAW			Y <sub>3</sub>	−sin ψ <sub>1</sub>		cos φ cos ψ <sub>1</sub>	sin φ cos ψ <sub>1</sub>
PITCH			Z <sub>3</sub>	sin θ <sub>2</sub> cos ψ <sub>1</sub>		cos φ sin θ <sub>2</sub> sin ψ <sub>1</sub>	sin φ sin θ <sub>2</sub> sin ψ <sub>1</sub>
CASE 6		INITIAL VECTOR COMPONENTS			Direct — $\dot{\phi}_3 = \dot{\phi} \cos \theta_1 \cos \psi_2 + \dot{\theta}_1 \sin \psi_2$ $\dot{\theta}_3 = -\dot{\phi} \cos \theta_1 \sin \psi_2 + \dot{\theta}_1 \cos \psi_2$ $\dot{\psi} = \dot{\phi} \sin \theta_1 + \dot{\psi}_2$ Inverse — $\dot{\phi} = \dot{\phi}_3 \sec \theta_1 \cos \psi_2 - \dot{\theta}_3 \sec \theta_1 \sin \psi_2$ $\dot{\theta}_1 = \dot{\phi}_3 \sin \psi_2 + \dot{\theta}_3 \cos \psi_2$ $\dot{\psi}_2 = -\dot{\phi}_3 \tan \theta_1 \cos \psi_2 + \dot{\theta}_3 \tan \theta_1 \sin \psi_2 + \dot{\psi}_3$		
ROLL		TRANSFORMED VECTOR COMPONENTS	X <sub>3</sub>	cos θ <sub>1</sub> cos ψ <sub>2</sub>		cos φ sin ψ <sub>2</sub>	sin φ sin ψ <sub>2</sub>
PITCH			Y <sub>3</sub>	−cos θ <sub>1</sub> sin ψ <sub>2</sub>		cos φ cos ψ <sub>2</sub>	sin φ cos ψ <sub>2</sub>
YAW			Z <sub>3</sub>	sin θ <sub>1</sub>		−sin φ cos θ <sub>1</sub>	cos φ cos θ <sub>1</sub>

NOTES:

- (a) X, Y, Z = Original coordinate axes.  
 X<sub>1</sub>, Y<sub>1</sub>, Z<sub>1</sub> }  
 X<sub>2</sub>, Y<sub>2</sub>, Z<sub>2</sub> } Intermediate coordinate axes.  
 X<sub>3</sub>, Y<sub>3</sub>, Z<sub>3</sub> = Final coordinate axes.

- (b) φ<sub>1</sub> denotes rotation about X<sub>1</sub>-axis.  
 θ<sub>1</sub> denotes rotation about Y<sub>1</sub>-axis.  
 ψ<sub>1</sub> denotes rotation about Z<sub>1</sub>-axis.

- (c) Direct transformation equations — sum horizontally along each row of the transformation matrix.  
 Inverse transformation equations — sum vertically down each column of the transformation matrix.

# Contrails

$$\begin{aligned}
 a_X &= (\cos \theta_1 \cos \psi) a_{X_3} \\
 &+ (\sin \phi_2 \sin \theta_1 \cos \psi - \cos \phi_2 \sin \psi) a_{Y_3} \\
 &+ (\cos \phi_2 \sin \theta_1 \cos \psi + \sin \phi_2 \sin \psi) a_{Z_3}
 \end{aligned}$$

A general rotation transformation of vector components from one coordinate-axes system to another may be interpreted in terms of direction cosines. The direction cosines are defined as the cosines of the angles between each of the final coordinate axes  $X_3$ ,  $Y_3$ , and  $Z_3$  and each of the original coordinate axes  $X$ ,  $Y$ , and  $Z$ . Thus there are nine angles required to describe a general rotation of rectangular-coordinate axes. Direction angles that locate the  $X_3$ -axis with respect to the original  $X$ -,  $Y$ -, and  $Z$ -axes are illustrated in the figure below. Similarly, direction angles are defined for the  $Y_3$ - and  $Z_3$ -axes.

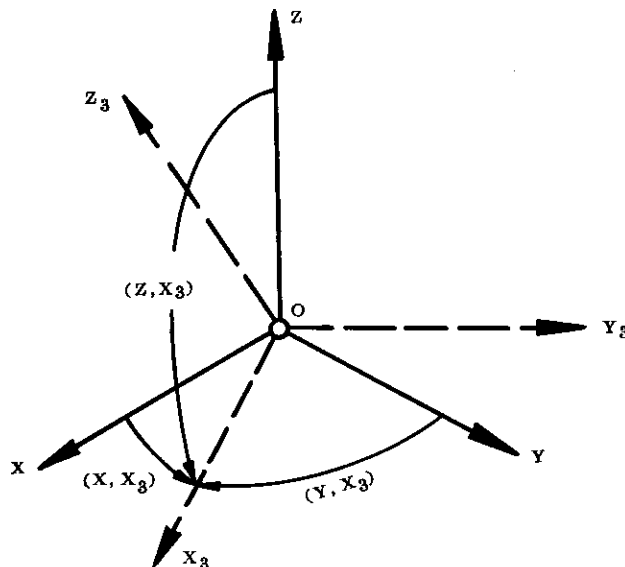

FIGURE 13 GENERAL ROTATION ABOUT ORIGIN — DIRECTION-COSINE DESCRIPTION OF ROTATION  
(DIRECTION ANGLES FOR  $X_3$  AXIS)

The direction-angle notation used is as follows:

- $(X, X_3)$  = Angle between  $X$ - and  $X_3$ -axes.
- $(Y, X_3)$  = Angle between  $Y$ - and  $X_3$ -axes.
- $(Z, X_3)$  = Angle between  $Z$ - and  $X_3$ -axes, etc.

The cosines of the direction angles may be arranged as a vector transformation matrix and used, exactly as in the preceding Section, to transform vector components. The vector transformation matrix of direction cosines is shown in table 3.

TABLE 3  
VECTOR TRANSFORMATION MATRIX OF DIRECTION COSINES

		INITIAL VECTOR COMPONENTS		
		X	Y	Z
TRANSFORMED VECTOR COMP.	$X_3$	$\cos (X, X_3)$	$\cos (Y, X_3)$	$\cos (Z, X_3)$
	$Y_3$	$\cos (X, Y_3)$	$\cos (Y, Y_3)$	$\cos (Z, Y_3)$
	$Z_3$	$\cos (X, Z_3)$	$\cos (Y, Z_3)$	$\cos (Z, Z_3)$



Relations for the direction cosines in terms of the orientation angles  $\phi$ ,  $\theta$ , and  $\psi$  may be obtained by equating corresponding elements of the above matrix and the appropriate matrix of table 2. For example,

$$\cos (Y, Z_3) = \cos \phi_2 \sin \theta_1 \sin \psi - \sin \phi_2 \cos \psi$$

for axis-orientation angles defined by the rotation sequence of Case 1 and

$$\cos (Y, Z_3) = -\sin \phi_1$$

when the orientation angles are defined as in Case 3.

### 3. RECTANGULAR COORDINATES TO CURVILINEAR COORDINATES

The transformation of rectangular space coordinates to a curvilinear-coordinate system involves a nonlinear coordinate change. The relations used to change from rectangular coordinates to spherical coordinates are given as equation 16 and those used for the transformation to cylindrical coordinates are given as equation 17. In both cases it can be seen (figures 14 and 15) that the transformation equations are statements of simple trigonometric relationships.

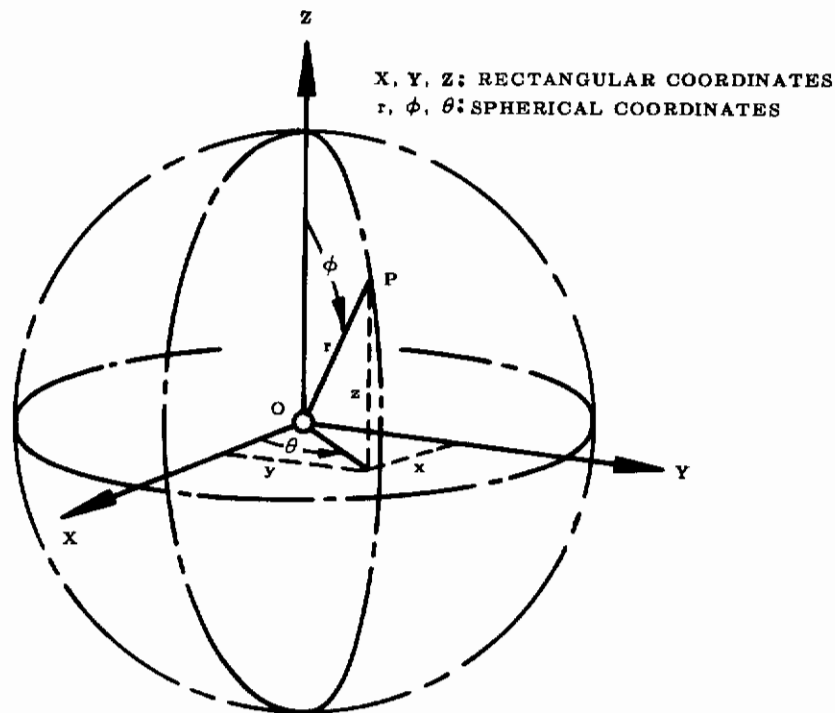

**FIGURE 14 RECTANGULAR - SPHERICAL COORDINATES**

Rectangular to spherical coordinates:

$$r = \sqrt{x^2 + y^2 + z^2}$$

$$\phi = \tan^{-1} \frac{\sqrt{x^2 + y^2}}{z}$$

$$\theta = \tan^{-1} \frac{y}{x}$$

Spherical to rectangular coordinates:

$$x = r \sin \phi \cos \theta$$

$$y = r \sin \phi \sin \theta$$

$$z = r \cos \phi$$

(16)

# Contrails

Rectangular to cylindrical coordinates:

$$r = \sqrt{x^2 + y^2}$$

$$\theta = \tan^{-1} \frac{y}{x}$$

$$z = z$$

Cylindrical to rectangular coordinates:

$$x = r \cos \theta$$

$$y = r \sin \theta$$

$$z = z$$

(17)

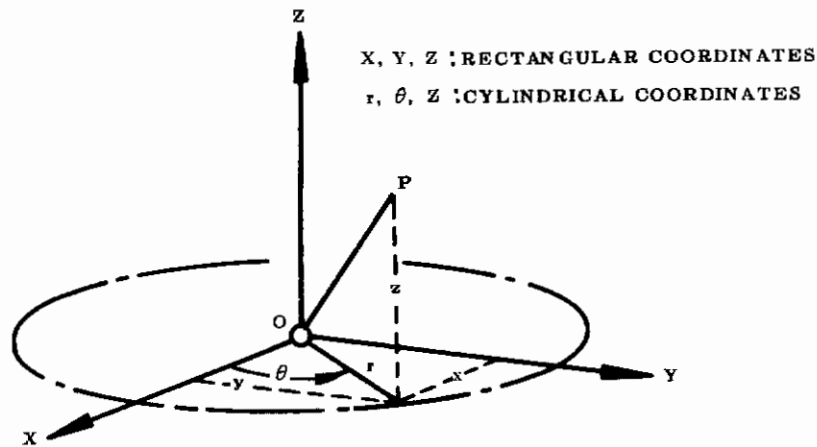

FIGURE 15 RECTANGULAR - CYLINDRICAL COORDINATES

It is important to note that base vectors at each point in the preceding curvilinear-coordinate systems are defined as orthogonal. Consequently, at a given point, transformation of vector components from rectangular to spherical (or cylindrical) coordinates is a transformation between rectangular axes and corresponds to a rotation of the axes system at the point. Thus appropriate transformation matrices from table 2 may be used directly to transform vector components from rectangular to spherical (or cylindrical) coordinates at a point.

For example, at a point the vector

$$\begin{aligned} \mathbf{V} &= V_x \mathbf{i} + V_y \mathbf{j} + V_z \mathbf{k} \\ &= V_r \mathbf{l}_r + V_\phi \mathbf{l}_\phi + V_\theta \mathbf{l}_\theta \end{aligned}$$

may be changed from rectangular components  $(V_x, V_y, V_z)$  to spherical components  $(V_r, V_\phi, V_\theta)$  by a linear transformation corresponding to one of the transformation matrices given in table 2. This method is used in the following paragraph to transform from spherical to flight-path coordinates.

## SPHERICAL COORDINATES

The relations used to change from rectangular to spherical coordinates are given in equation 16. As is noted there, this is a nonlinear transformation. However, at any point in a space described by spherical coordinates, a rotation of local base vectors is accomplished by a rotation of rectangular axes.

In this Section, presentation of vector transformations is limited to the change from local spherical-coordinate axes to flight-path axes. These axes are defined and illustrated in Section 2. This transformation serves to further illustrate the use of rectangular-coordinate transformations (table 2).

The rotation of the local base vectors at point P from a spherical-coordinate orientation to flight-path axes is defined in Section 2 on page 5. It is noted that this rotation corresponds to the roll-pitch-yaw sequence (Case 6 of table 2) of the rectangular-coordinate transformations. Thus by identifying quantities of the transformation (Case 6, table 2) with the notation defined for spherical and flight-path coordinates in Section 2 the desired transformation matrix is obtained. The correspondence between terms is given in table 4.

TABLE 4  
CORRESPONDENCE BETWEEN RECTANGULAR-COORDINATE TRANSFORMATION  
AND SPHERICAL - FLIGHT-PATH-COORDINATE TRANSFORMATION

Item in Rectangular-Coordinate Transformation (Case 6, Table 2)		Corresponding item in Spherical - Flight-Path-Coordinate System (Section 2)	
Initial Vector Components	X	$G_r$	Vector Components Along Spherical-Coordinate Directions
	Y	$G_\phi$	
	Z	$G_\theta$	
Transformed Vector Components	$X_s$	$G_u$	Vector Components Along Flight-Path-Coordinate Directions
	$Y_s$	$G_v$	
	$Z_s$	$G_w$	
Orientation Angles	$\phi$	$(90-\delta)$	Flight-Path Orientation Angles
	$\theta_1$	$\gamma$	
	$\psi_2$	$\eta$	

A general vector  $\mathbf{G}$  may be expressed as follows:

$$\mathbf{G} = G_r \mathbf{i}_r + G_\phi \mathbf{i}_\phi + G_\theta \mathbf{i}_\theta \quad (\text{spherical coordinates})$$

$$\mathbf{G} = G_u \mathbf{e}_u + G_v \mathbf{e}_v + G_w \mathbf{e}_w \quad (\text{flight-path coordinates})$$

Substitution of the above items in the vector transformation matrix of table 2, Case 6, results in the transformation shown in table 5.

Note:  $\sin(90 - \delta) = \cos \delta$  and  $\cos(90 - \delta) = \sin \delta$

TABLE 5  
VECTOR TRANSFORMATION MATRIX  
SPHERICAL COORDINATES TO FLIGHT-PATH COORDINATES

		COMPONENTS ALONG SPHERICAL COORDINATES		
		$G_r$	$G_\phi$	$G_\theta$
COMP. ALONG FLT.-PATH COORD.	$G_u$	$\cos \gamma \cos \eta$	$\sin \delta \sin \eta + \cos \delta \sin \gamma \cos \eta$	$\cos \delta \sin \eta - \sin \delta \sin \gamma \cos \eta$
	$G_v$	$-\cos \gamma \sin \eta$	$\sin \delta \cos \eta - \cos \delta \sin \gamma \sin \eta$	$\cos \delta \cos \eta + \sin \delta \sin \gamma \sin \eta$
	$G_w$	$\sin \gamma$	$-\cos \delta \cos \gamma$	$\sin \delta \cos \gamma$

Base (unit) vectors  $\mathbf{l}_r$ ,  $\mathbf{l}_\phi$ ,  $\mathbf{l}_\theta$  are aligned along spherical-coordinate directions.

Base (unit) vectors  $\mathbf{e}_n$ ,  $\mathbf{e}_s$ ,  $\mathbf{e}_v$  are aligned along the flight path (  $\mathbf{e}_v$  is along the velocity vector of the point P ).

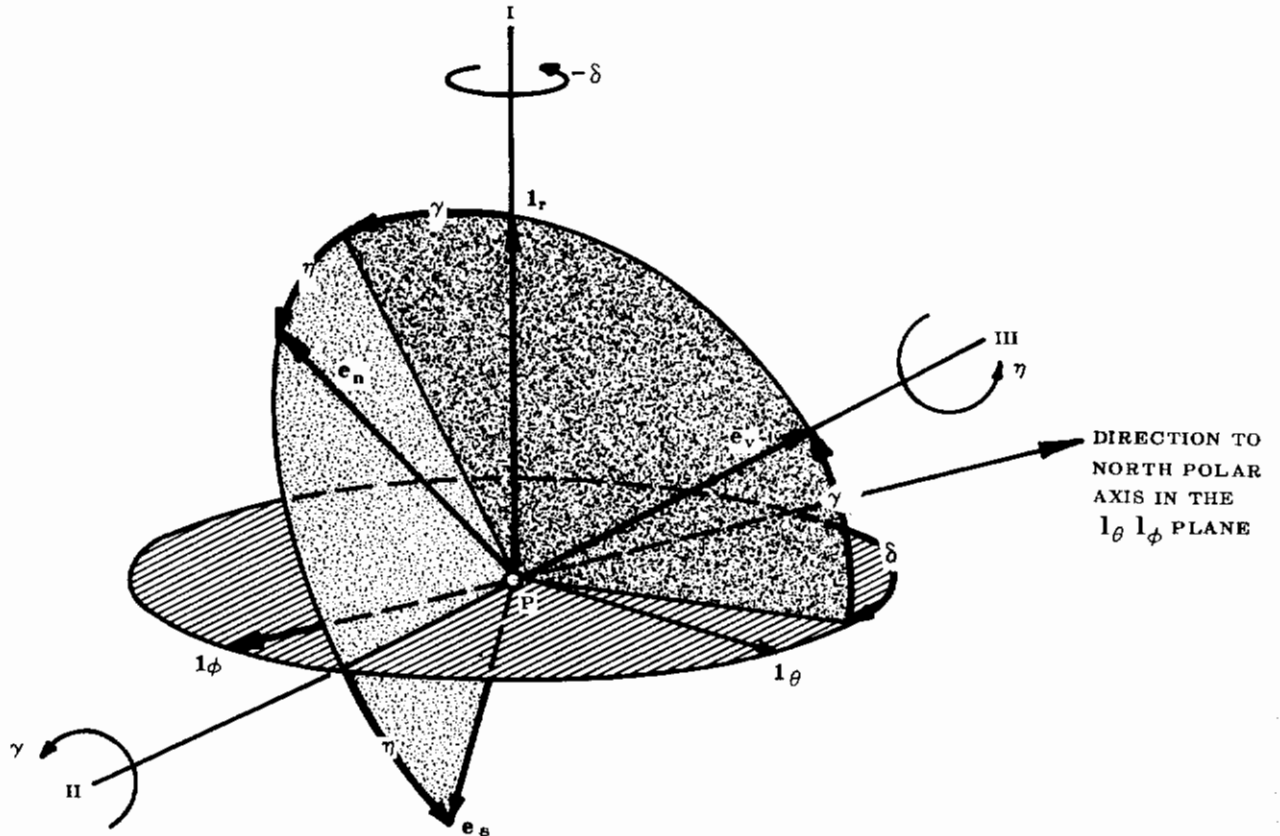

FIGURE 16 ROTATION OF BASE VECTORS FROM SPHERICAL TO FLIGHT-PATH COORDINATES

## CYLINDRICAL COORDINATES

Equations relating rectangular and cylindrical space coordinates are given on page 26. This coordinate change is nonlinear, as is the change to spherical coordinates. The discussion concerning rotation of local base vectors for spherical-coordinate systems also applies to cylindrical-coordinate systems. A similar procedure may be used to obtain the transformation matrix for a rotation of the local base vectors.

## RIGID-BODY TRANSFORMATIONS

Transformations useful in the analysis of rigid-body motion follow directly from the rotation of rectangular-coordinate axes. The translation of a rigid body may be considered as the motion of a particle concentrated at the center of gravity of the body, and the foregoing Sections may then be applied. Rotation of a body about its center of mass, however, introduces additional degrees of freedom that depend upon the inertia characteristics of the body.

The transformation relations useful in the analysis of rigid-body motion are given in this Section. First the general transformation of vector components and inertia parameters is discussed. Then specialized transformations such as those used in conventional aircraft-motion analysis are given.

### GENERAL AXES TRANSFORMATIONS

The transformations of this Section are limited to rotations of rectangular-coordinate systems. As is noted previously for spherical and cylindrical coordinates, the rotation of a rectangular axis system about its origin may be utilized for local orthogonal axis systems even though the origin of this system may be defined with respect to a curvilinear coordinate system.

Vector components are transformed in the case of rigid-body motion in the same manner as vector components are transformed for particle motion. Thus the transformation matrices and method given on page 23 are directly applicable to the rigid-body case.

General transformations of the inertia parameter, which are important in rigid-body rotational motion, do not have the simple form of the vector transformation. This transformation is presented for a general rotation of the coordinate axes.

The general transformation for moment-of-inertia and product-of-inertia terms may be obtained from the vector transformation matrix and its inverse. This procedure, given in reference 10, is outlined below.

Rotational motion of a rigid body is expressed by the fundamental relation

$$\mathbf{l} = [\mathbf{I}]\boldsymbol{\omega} \quad (18)$$

where  $\mathbf{l}$  is the angular momentum vector and  $\boldsymbol{\omega}$  is the angular velocity vector. The inertia matrix  $[\mathbf{I}]$  is defined as follows:

$$[\mathbf{I}] = \begin{bmatrix} I_X & -I_{XY} & -I_{XZ} \\ -I_{XY} & I_Y & -I_{YZ} \\ -I_{XZ} & -I_{YZ} & I_Z \end{bmatrix}$$

In this matrix  $I_X$ ,  $I_Y$ , and  $I_Z$  are the mass moments of inertia and  $I_{YZ}$ ,  $I_{XZ}$ , and  $I_{XY}$  are the mass products of inertia with reference to the X, Y, and Z axes, respectively.

The above vector equation for rigid-body rotation is independent of the coordinate system selected to represent the vectors. Hence, if the subscript o denotes reference to the original and 3 to the transformed coordinate system, the equation for rigid-body rotation may be written

$$\mathbf{l}_o = [\mathbf{I}_o]\boldsymbol{\omega}_o \quad \text{or} \quad \mathbf{l}_3 = [\mathbf{I}_3]\boldsymbol{\omega}_3$$

# Contrails

Vector transformations from table 2 may then be used to change the vectors  $\mathbf{l}_0$  and  $\boldsymbol{\omega}_0$  from the original to the new coordinate system. These transformation relations may be expressed as follows:

$$\begin{aligned}\mathbf{l}_3 &= [\Gamma] \mathbf{l}_0 \\ \boldsymbol{\omega}_3 &= [\Gamma] \boldsymbol{\omega}_0 \quad \text{or} \quad \boldsymbol{\omega}_0 = [\Gamma]^{-1} \boldsymbol{\omega}_3\end{aligned}$$

where the vector transformation matrix  $[\Gamma]$  and its inverse  $[\Gamma]^{-1}$  denote a general rotation of axes as given on page 20.

Combining the transformed vectors with the body-rotation equation results in the desired transformation relation for the inertia matrix. Thus

$$\mathbf{l}_3 = [\Gamma] [I_0] \boldsymbol{\omega}_0 = [\Gamma] [I_0] [\Gamma]^{-1} \boldsymbol{\omega}_3 = [I_3] \boldsymbol{\omega}_3$$

Hence

$$[I_3] = [\Gamma] [I_0] [\Gamma]^{-1} \tag{19}$$

Expansion of this transformation relation for a general rotation defined by three orientation angles results in a complex expression having a large number of terms. This is a straightforward procedure using matrix multiplication, but in most cases it is impractical and unnecessary. Body symmetry usually reduces two of the product-of-inertia terms to zero, and in many cases a simple planar rotation is sufficient to define the axes rotation. These practical considerations simplify the expansion of the inertia transformation relations used later.

In order to illustrate the transformation of a matrix, the foregoing procedure is expanded below for a planar rotation. This particular case provides a general form that is subsequently useful in the transformation of airplane stability derivatives.

If  $[A]$  and  $[\tilde{A}]$  represent the original and the transformed matrices, respectively, the matrix transformation relation is

$$[\tilde{A}] = [\Gamma] [A] [\Gamma]^{-1}$$

where

$$[A] = \begin{bmatrix} a_{xx} & a_{xy} & a_{xz} \\ a_{yx} & a_{yy} & a_{yz} \\ a_{zx} & a_{zy} & a_{zz} \end{bmatrix} \quad \text{and} \quad [\tilde{A}] = \begin{bmatrix} \tilde{a}_{xx} & \tilde{a}_{xy} & \tilde{a}_{xz} \\ \tilde{a}_{yx} & \tilde{a}_{yy} & \tilde{a}_{yz} \\ \tilde{a}_{zx} & \tilde{a}_{zy} & \tilde{a}_{zz} \end{bmatrix}$$

If the vector transformation matrix  $[\Gamma]$  corresponds to a simple rotation about the Y-axis, the above equation may be written as follows:

$$[\tilde{A}] = \begin{bmatrix} \cos \theta & 0 & -\sin \theta \\ 0 & 1 & 0 \\ \sin \theta & 0 & \cos \theta \end{bmatrix} \begin{bmatrix} a_{xx} & a_{xy} & a_{xz} \\ a_{yx} & a_{yy} & a_{yz} \\ a_{zx} & a_{zy} & a_{zz} \end{bmatrix} \begin{bmatrix} \cos \theta & 0 & \sin \theta \\ 0 & 1 & 0 \\ -\sin \theta & 0 & \cos \theta \end{bmatrix}$$

Note that the matrix  $[\Gamma]$  may be obtained from table 2. For example, using the vector transformation matrix for case 1 of this table, substitution of  $\psi=0$ ,  $\theta_1=\theta$  and  $\phi_2=0$  results in the above matrix.

Expansion of the matrix multiplication above gives the transformed matrix. Thus

$$[\tilde{A}] = \begin{bmatrix} [a_{xx} \cos^2 \theta + a_{zz} \sin^2 \theta & [a_{xy} \cos \theta - a_{zy} \sin \theta] & [(a_{xx} - a_{zz}) \sin \theta \cos \theta \\ - (a_{xz} + a_{zx}) \sin \theta \cos \theta] & & + a_{xz} \cos^2 \theta - a_{zx} \sin^2 \theta] \\ [a_{yx} \cos \theta - a_{yz} \sin \theta] & [a_{yy}] & [a_{yx} \sin \theta + a_{yz} \cos \theta] \\ [(a_{xx} - a_{zz}) \sin \theta \cos \theta & [a_{xy} \sin \theta + a_{zy} \cos \theta] & [a_{xx} \sin^2 \theta + a_{zz} \cos^2 \theta \\ + a_{xz} \cos^2 \theta - a_{zx} \sin^2 \theta] & & + (a_{xz} + a_{zx}) \sin \theta \cos \theta] \end{bmatrix}$$

The elements of this matrix are readily identified with the elements  $\tilde{a}_{xx}$ ,  $\tilde{a}_{xy}$ ,  $\tilde{a}_{zz}$  of the transformed matrix ( $\tilde{A}$ ). The equations transforming the quantities represented by the matrix elements are given below. These relations are limited, of course, to a simple planar rotation about the Y-axis.

$$\left. \begin{aligned} \tilde{a}_{xx} &= a_{xx} \cos^2 \theta + a_{zz} \sin^2 \theta - (a_{xz} + a_{zx}) \sin \theta \cos \theta \\ \tilde{a}_{xy} &= a_{xy} \cos \theta - a_{zy} \sin \theta \\ \tilde{a}_{xz} &= (a_{xx} - a_{zz}) \sin \theta \cos \theta + a_{xz} \cos^2 \theta - a_{zx} \sin^2 \theta \\ \tilde{a}_{yx} &= a_{yx} \cos \theta - a_{yz} \sin \theta \\ \tilde{a}_y &= a_{yy} \\ \tilde{a}_{yz} &= a_{yx} \sin \theta + a_{yz} \cos \theta \\ \tilde{a}_{zx} &= (a_{xx} - a_{zz}) \sin \theta \cos \theta + a_{xz} \cos^2 \theta - a_{zx} \sin^2 \theta \\ \tilde{a}_{zy} &= a_{xy} \sin \theta + a_{zy} \cos \theta \\ \tilde{a}_{zz} &= a_{xx} \sin^2 \theta + a_{zz} \cos^2 \theta + (a_{xz} + a_{zx}) \sin \theta \cos \theta \end{aligned} \right\} \quad (20)$$

These equations are used in subsequent Sections for the transformation of vehicle inertia parameters and stability derivatives.

## VEHICLE TRANSFORMATIONS

Transformations of vectors, inertia parameters, and stability derivatives used in vehicle motion analysis are summarized in this Section. These transformations refer to the vehicle axes systems defined in Section 2 and use established aircraft notation and terminology.

It is convenient to consider the vehicle transformations in two groups. The first group involves single rotations about the lateral (Y) axis. A change from *body axes* to *stability axes* is a single rotation of this type. The second group comprises cases of general rotation such as a change from *earth axes* to *body axes*.

The inertia-parameter and stability-derivative transformations are not given for the second group. The general rotation cases are used principally to define orientation of axes fixed on the vehicle, with respect to the earth or the relative wind. As is noted previously (page 16), the inertia parameters become functions of the orientation angles and the analysis of the motion is then unnecessarily complicated. The transformation of the inertia matrix for a multiple rotation may be developed from the general relationship given by equation 19.

### 1. SINGLE ROTATION

The pitch rotations used to change from *stability* or *principal axes* to *body axes*, and vice versa, are illustrated in figure 17. These axes and the notation are defined in Section 2. Both *stability axes* and *principal axes* are fixed to the vehicle and are therefore simply special "body" axes. The angles between these various axes systems are measured as rotations about the Y-axis.

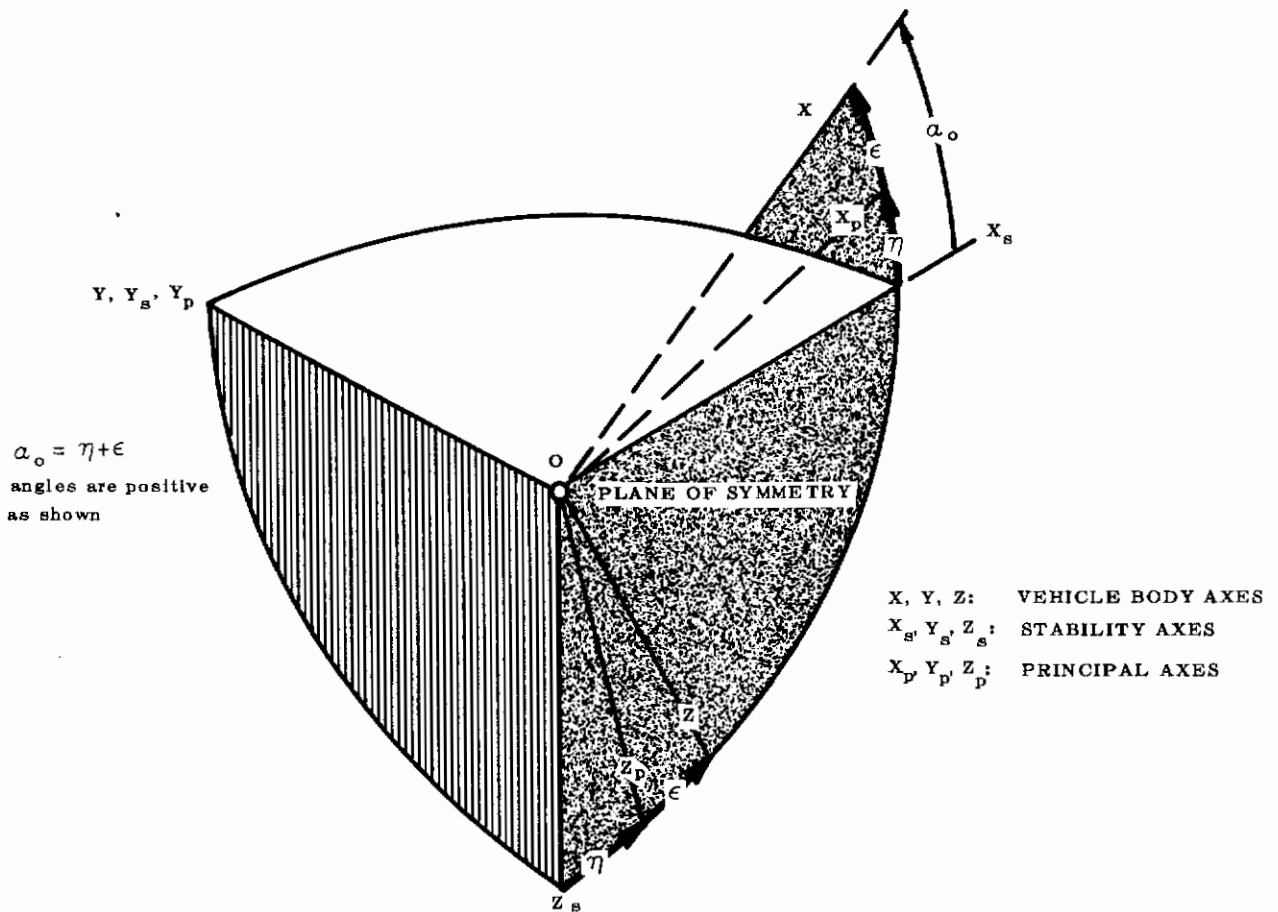

FIGURE 17 BODY - STABILITY - PRINCIPAL AXES ROTATION - PITCH

TABLE 6

VECTOR-TRANSFORMATION MATRICES  
BODY-STABILITY-PRINCIPAL AXES

STABILITY AXES TO BODY AXES		VECTOR COMPONENTS - STABILITY AXES		
		$X_s$	$Y_s$	$Z_s$
VECTOR COMPONENTS BODY AXES	X	$\cos \alpha_0$	0	$-\sin \alpha_0$
	Y	0	1	0
	Z	$\sin \alpha_0$	0	$\cos \alpha_0$
PRINCIPAL AXES TO BODY AXES		VECTOR COMPONENTS - PRINCIPAL AXES		
		$X_p$	$Y_p$	$Z_p$
VECTOR COMPONENTS BODY AXES	X	$\cos \epsilon$	0	$-\sin \epsilon$
	Y	0	1	0
	Z	$\sin \epsilon$	0	$\cos \epsilon$
STABILITY AXES TO PRINCIPAL AXES		VECTOR COMPONENTS - STABILITY AXES		
		$X_s$	$Y_s$	$Z_s$
VECTOR COMPONENTS PRINCIPAL AXES	$X_p$	$\cos \eta$	0	$-\sin \eta$
	$Y_p$	0	1	0
	$Z_p$	$\sin \eta$	0	$\cos \eta$

DIRECT TRANSFORMATION - Sum horizontally along each row.

INDIRECT TRANSFORMATION - Sum vertically down each column.



Vector transformation matrices may be obtained directly from those in table 2 by letting  $\phi_1 = 0$ ,  $\psi_1 = 0$ , and  $\theta_1 = \alpha_0$ ,  $\epsilon$ , or  $\eta$ . These vector transformation matrices are given in table 6. Examples of the use of these matrices may be found on page 20.

Transformation of the inertia matrix for a general rotation is discussed on pages 29–31. However, for the vehicle axis systems used in this Section the XZ-plane is a plane of symmetry\* and only rotations about the Y-axis are considered. These conditions greatly simplify the inertia matrix and its transformation.

The inertia matrices of an aircraft referred to *body*, *stability*, and *principal axes* are given below.

$$\text{Body Axes} \quad [I] = \begin{bmatrix} I_X & 0 & -I_{XZ} \\ 0 & I_Y & 0 \\ -I_{XZ} & 0 & I_Z \end{bmatrix} \quad (21)$$

$$\text{Stability Axes} \quad [I_s] = \begin{bmatrix} I_{X_s} & & -I_{XZ_s} \\ 0 & I_{Y_s} & 0 \\ -I_{XZ_s} & 0 & I_{Z_s} \end{bmatrix} \quad (22)$$

$$\text{Principal Axes**} \quad [I_p] = \begin{bmatrix} I_{X_p} & 0 & 0 \\ 0 & I_{Y_p} & 0 \\ 0 & 0 & I_{Z_p} \end{bmatrix} \quad (23)$$

The transformation relations for the elements of the above matrices are given in table 7. These equations are obtained by identifying elements of the inertia matrices with the corresponding elements of the general matrix transformation on pages 30 and 31. The appropriate angle substitution may be determined from figure 17.

Some additional relations pertinent to inertia-parameter transformations are listed below.

1.  $\alpha_0 = \eta + \epsilon$
2.  $\tan 2\epsilon = \frac{2 I_{XZ}}{I_Z - I_X}$
3.  $\tan 2\eta = \frac{2 I_{XZ_s}}{I_{Z_s} - I_{X_s}}$

Stability derivatives are used extensively in the analysis of aircraft motion. They are introduced with the linearization of the aerodynamic force and moment relations. These derivatives may be conveniently arranged in matrix form; hence it is frequently necessary to transform them from one axes system to another. Transformations relating stability derivatives in terms of *body* and *stability axes* are given in this Section. This involves a simple rotation of the axes system about the Y-axis and follows directly from the matrix transformation on page 30.

The notation for stability derivatives is confused in existing literature. It is therefore appropriate to reiterate here the statement on page 129 of reference 4 reminding the reader to exercise extreme care in using the literature that involves stability derivatives. This is necessary to insure that the definitions of the symbols used are fully understood and that comparisons and results will be correctly interpreted. (Also see reference 2.)

Notation in this report is consistent with that used in references 3 and 4. This notation, defined in Section 4, implies differentiation of direct forces and moments with respect to perturbation quantities.

\* By symmetry about the XZ-plane,  $I_{XY}$  and  $I_{YZ}$  are zero.

\*\* *Principal axes* are defined by the condition  $I_{X_p} = I_{Y_p} = I_{Z_p} = 0$

TABLE 7

INERTIA MATRIX ELEMENT TRANSFORMATIONS

BODY - STABILITY - PRINCIPAL AXES

Angles are positive as shown on Page 3 2

INERTIA PARAMETERS BODY AXES	STABILITY TO BODY AXES				PRINCIPAL TO BODY AXES			
	Coefficient of Element Transformation Equation				Coefficient of Element Transformation Equation			
	$\sin^2 \alpha_0$	$\cos^2 \alpha_0$	$\sin \alpha_0 \cos \alpha_0$	1	$\sin^2 \epsilon$	$\cos^2 \epsilon$	$\sin \epsilon \cos \epsilon$	1
$I_x$	$I_{z_B}$	$I_{x_B}$	$2I_{xz_B}$	0	$I_{z_P}$	$I_{x_P}$	0	0
$I_y$	0	0	0	$I_{y_B}$	0	0	0	$I_{y_P}$
$I_z$	$I_{x_B}$	$I_{z_B}$	$-2I_{xz_B}$	0	$I_{x_P}$	$I_{z_P}$	0	0
$I_{xz}$	$-I_{xz_B}$	$I_{xz_B}$	$I_{z_B} - I_{x_B}$	0	0	0	$I_{z_P} - I_{x_P}$	0

INERTIA PARAMETERS STABILITY AXES	BODY TO STABILITY AXES				PRINCIPAL TO STABILITY AXES			
	Coefficient of Element Transformation Equation				Coefficient of Element Transformation Equation			
	$\sin^2 \alpha_0$	$\cos^2 \alpha_0$	$\sin \alpha_0 \cos \alpha_0$	1	$\sin^2 \eta$	$\cos^2 \eta$	$\sin \eta \cos \eta$	1
$I_{x_B}$	$I_z$	$I_x$	$-2I_{xz}$	0	$I_{z_P}$	$I_{x_P}$	0	0
$I_{y_B}$	0	0	0	$I_y$	0	0	0	$I_y$
$I_{z_B}$	$I_x$	$I_z$	$2I_{xz}$	0	$I_{x_P}$	$I_{z_P}$	0	0
$I_{xz_B}$	$-I_{xz}$	$I_{xz}$	$I_x - I_z$	0	0	0	$I_{x_P} - I_{z_P}$	0

INERTIA PARAMETERS PRINCIPAL AXES	BODY TO PRINCIPAL AXES				STABILITY TO PRINCIPAL AXES			
	Coefficient of Element Transformation Equation				Coefficient of Element Transformation Equation			
	$\sin^2 \epsilon$	$\cos^2 \epsilon$	$\sin \epsilon \cos \epsilon$	1	$\sin^2 \eta$	$\cos^2 \eta$	$\sin \eta \cos \eta$	1
$I_{x_P}$	$I_z$	$I_x$	$-2I_{xz}$	0	$I_{z_B}$	$I_{x_B}$	$2I_{xz_B}$	0
$I_{y_P}$	0	0	0	$I_y$	0	0	0	$I_{y_B}$
$I_{z_P}$	$I_x$	$I_z$	$2I_{xz}$	0	$I_{x_B}$	$I_{z_B}$	$-2I_{xz_B}$	0
0*	$-I_{xz}$	$I_{xz}$	$I_x - I_z$	0	$-I_{xz_B}$	$I_{xz_B}$	$I_{z_B} - I_{x_B}$	0

\* $I_{xz_P} = 0$

Write equations for inertia parameters by summing across the row.

Example:  $I_{z_B} = I_x \sin^2 \alpha_0 + I_z \cos^2 \alpha_0 + 2I_{xz} \sin \alpha_0 \cos \alpha_0 + (0) 1$

$I_{z_B} = I_{x_P} \sin^2 \eta + I_{z_P} \cos^2 \eta + (0) \sin \alpha_0 \cos \alpha_0 + (0) 1$

# Contrails

The basic stability derivatives may be arranged in the six matrices listed below. With the assumption of vehicle symmetry about the XZ-plane, these matrices have been simplified to the form shown. Derivatives of symmetric forces with respect to asymmetric variables are neglected and certain negligible derivatives are taken to be zero. These considerations are discussed further in Section 4.

<i>Matrix Type</i>	<i>Matrix Symbol</i>	
Force-Velocity	$[F_v] =$	$\begin{bmatrix} X_u & 0 & X_w \\ 0 & Y_v & 0 \\ Z_u & 0 & Z_w \end{bmatrix} \quad (24)$

Force-Rotary	$[F_\omega] =$	$\begin{bmatrix} 0 & X_{\eta} & 0 \\ Y_p & 0 & Y_r \\ 0 & Z_{\eta} & 0 \end{bmatrix} \quad (25)$
--------------	----------------	--

Force-Control	$[F_\delta] =$	$\begin{bmatrix} 0 & X_{\delta_a} & 0 \\ Y_{\delta_a} & 0 & Y_{\delta_r} \\ 0 & Z_{\delta_e} & 0 \end{bmatrix} \quad (26)$
---------------	----------------	--

Moment-Velocity	$[G_v] =$	$\begin{bmatrix} 0 & L_v & 0 \\ M_o & 0 & M_w \\ 0 & N_v & 0 \end{bmatrix} \quad (27)$
-----------------	-----------	--

Moment-Rotary	$[G_\omega] =$	$\begin{bmatrix} L_p & 0 & L_r \\ 0 & M_q & 0 \\ N_p & 0 & N_r \end{bmatrix} \quad (28)$
---------------	----------------	--

Moment-Control	$[G_\delta] =$	$\begin{bmatrix} L_{\delta_a} & 0 & L_{\delta_r} \\ 0 & M_{\delta_e} & 0 \\ N_{\delta_a} & 0 & N_{\delta_r} \end{bmatrix} \quad (29)$
----------------	----------------	---

As was the case with elements of the inertia matrix, elements of the velocity and rotary matrices may be transformed according to the relations on page 31. The control-derivative matrices, however, require specialized treatment because the control displacements are independent of the *stability* and *body axis* systems.

A procedure similar to that used for transformation of the inertia matrix (page 29) may be used to find the transformation relations for the control-derivative matrices. Consider a vector relation of the form

$$f = [B] \delta$$

in which the components of the displacement  $\delta$  are independent of the coordinate system used to define the components of  $f$ . Components of the vector  $f$  may be transformed from one coordinate system (subscript o) to another (subscript 3), which has been rotated about the origin. The vector relation above may be expressed as

$$f_o = [B_o] \delta \quad \text{or} \quad f_3 = [B_3] \delta$$

One of the vector transformation matrices  $[\Gamma]$  from table 2 may be used for a general rotation. Thus

$$f_3 = [\Gamma] f_o = [\Gamma] [B_o] \delta = [B_3] \delta$$

The transformation relation for the matrix  $[B]$  is then

$$[B_3] = [\Gamma] [B_o]$$

Expansion of this equation for a planar rotation about the Y-axis results in the general form used in transforming

# Contrails

the stability derivatives that involve control variables. If the initial and transformed matrices are denoted by  $[B]$  and  $[\tilde{B}]$ , respectively, and the transformation matrix by  $[\theta]$ , the transformation relation becomes

$$[\tilde{B}] = [\theta] [B]$$

or

$$[\tilde{B}] = \begin{bmatrix} \tilde{b}_{xx} & \tilde{b}_{xy} & \tilde{b}_{xz} \\ \tilde{b}_{yx} & \tilde{b}_{yy} & \tilde{b}_{yz} \\ \tilde{b}_{zx} & \tilde{b}_{zy} & \tilde{b}_{zz} \end{bmatrix} = \begin{bmatrix} \cos \theta & 0 & -\sin \theta \\ 0 & 1 & 0 \\ \sin \theta & 0 & \cos \theta \end{bmatrix} \begin{bmatrix} b_{xx} & b_{xy} & b_{xz} \\ b_{yx} & b_{yy} & b_{yz} \\ b_{zx} & b_{zy} & b_{zz} \end{bmatrix}$$

Expanding the right side of this equation results in the transformed matrix  $[\tilde{B}]$ .

$$[\tilde{B}] = \begin{bmatrix} (b_{xx} \cos \theta - b_{zx} \sin \theta) & (b_{xy} \cos \theta - b_{zy} \sin \theta) & (b_{xz} \cos \theta - b_{zz} \sin \theta) \\ b_{yx} & b_{yy} & b_{yz} \\ (b_{xx} \sin \theta + b_{zx} \cos \theta) & (b_{xy} \sin \theta + b_{zy} \cos \theta) & (b_{xz} \sin \theta + b_{zz} \cos \theta) \end{bmatrix}$$

Finally, identifying elements of  $[\tilde{B}]$  with the above expansion of  $[\theta][B]$  gives the equations transforming the elements of the matrix  $[B]$  to the elements of  $[\tilde{B}]$ . These equations are

$$\left. \begin{aligned} \tilde{b}_{xx} &= b_{xx} \cos \theta - b_{zx} \sin \theta \\ \tilde{b}_{xy} &= b_{xy} \cos \theta - b_{zy} \sin \theta \\ \tilde{b}_{xz} &= b_{xz} \cos \theta - b_{zz} \sin \theta \\ \tilde{b}_{yx} &= b_{yx}; \tilde{b}_{yy} = b_{yy}; \tilde{b}_{yz} = b_{yz} \\ \tilde{b}_{zx} &= b_{xx} \sin \theta + b_{zx} \cos \theta \\ \tilde{b}_{zy} &= b_{xy} \sin \theta + b_{zy} \cos \theta \\ \tilde{b}_{zz} &= b_{xz} \sin \theta + b_{zz} \cos \theta \end{aligned} \right\} \quad (30)$$

The foregoing equations are used to transform the force-control and moment-control matrices. Special transformations may be devised as required by using the method of the preceding development or that used for the inertia matrix on page 30.

Stability derivative transformations between *stability* and *body axes* are tabulated in tables 8 and 9. The angle  $\alpha_0$  is defined in figure 17. A prime (') is used in these tables to designate the derivatives along *body axes*. In subsequent Sections the prime notation is deleted and the reference axes are as noted (see table 17).

The following example illustrates the use of the stability derivative transformation relations.

Given: Stability derivatives with respect to stability axes.

Find: The derivative of rolling moment with respect to rolling velocity  $L'_p$  referred to body axes.

Solution: Write equation from table 8 by summing terms along the row of  $L'_p$ .

$$L'_p = N_r \sin^2 \alpha_0 + L_p \cos^2 \alpha_0 - (L_r + N_p) \sin \alpha_0 \cos \alpha_0$$

TABLE 8  
STABILITY-DERIVATIVE TRANSFORMATIONS  
STABILITY AXES TO BODY AXES

MATRIX TYPE	MATRIX SYMBOL	BODY-AXES FORM	COEFFICIENT OF ELEMENT-TRANSFORMATION EQUATION					
			$\sin^2 \alpha_0$	$\cos^2 \alpha_0$	$\sin \alpha_0 \cos \alpha_0$	$\sin \alpha_0$	$\cos \alpha_0$	1
FORCE -- VELOCITY	$(F_V)$	$X'_u$	$Z_w$	$X_u$	$-X_w - Z_u$	0	0	0
		$X'_w$	$-Z_u$	$X_w$	$X_u - Z_w$	0	0	0
		$Y'_v$	0	0	0	0	0	$Y_v$
		$Z'_u$	$-X_w$	$Z_u$	$X_u - Z_w$	0	0	0
		$Z'_w$	$X_u$	$Z_w$	$X_w + Z_u$	0	0	0
FORCE -- ROTARY	$(F_\omega)$	$X'_q$	0	0	0	$-Z_{\dot{q}}$	$X_{\dot{q}}$	0
		$Y'_p$	0	0	0	$-Y_r$	$Y_p$	0
		$Y'_r$	0	0	0	$Y_p$	$Y_r$	0
		$Z'_q$	0	0	0	$X_{\dot{q}}$	$Z_{\dot{q}}$	0
FORCE -- CONTROL	$(F_\delta)$	$X'_{\delta_e}$	0	0	0	$-Z_{\delta_e}$	$X_{\delta_e}$	0
		$Y'_{\delta_a}$	0	0	0	0	0	$Y_{\delta_a}$
		$Y'_{\delta_r}$	0	0	0	0	0	$Y_{\delta_r}$
		$Z'_{\delta_e}$	0	0	0	$X_{\delta_e}$	$Z_{\delta_e}$	0
MOMENT -- VELOCITY	$(G_V)$	$L'_v$	0	0	0	$-N_v$	$L_v$	0
		$M'_u$	0	0	0	$-M_w$	$M_u$	0
		$M'_w$	0	0	0	$M_u$	$M_w$	0
		$N'_v$	0	0	0	$L_v$	$N_v$	0
MOMENT -- ROTARY	$(G_\omega)$	$L'_p$	$N_r$	$L_p$	$-L_r - N_p$	0	0	0
		$L'_r$	$-N_p$	$L_r$	$L_p - N_r$	0	0	0
		$M'_q$	0	0	0	0	0	$M_q$
		$N'_p$	$-L_r$	$N_p$	$L_p - N_r$	0	0	0
		$N'_r$	$L_p$	$N_r$	$L_r + N_p$	0	0	0
MOMENT -- CONTROL	$(G_\delta)$	$L'_{\delta_a}$	0	0	0	$-N_{\delta_a}$	$L_{\delta_a}$	0
		$L'_{\delta_r}$	0	0	0	$-N_{\delta_r}$	$L_{\delta_r}$	0
		$M'_{\delta_e}$	0	0	0	0	0	$M_{\delta_e}$
		$N'_{\delta_a}$	0	0	0	$L_{\delta_a}$	$N_{\delta_a}$	0
		$N'_{\delta_r}$	0	0	0	$L_{\delta_r}$	$N_{\delta_r}$	0

$\alpha_0$  is positive as shown on page 32

*Wind-tunnel stability axes* are used as reference axes for most wind-tunnel data. It is therefore necessary to transform these data to vehicle *stability axes* (or *body axes*) before using them in analysis of the motion of an aircraft. These axes are defined in Section 2. The transformation is a simple pitch rotation about the lateral (Y) axis. The rotation angle  $\zeta$  is the angle between the wind-tunnel-axis (or *body-axis*) angle of attack  $\alpha$  and the *stability axis* reference angle  $\alpha_0$  (reference 12).

Wind-tunnel axes may also be considered as general *wind axes*. In this case the transformation from wind-tunnel axes to *wind-tunnel stability axes* is a simple yaw rotation about the Z-axis through an angle  $\psi$ .

TABLE 9  
STABILITY-DERIVATIVE TRANSFORMATIONS  
BODY AXES TO STABILITY AXES

MATRIX TYPE	MATRIX SYMBOL	STABILITY-AXES FORM	COEFFICIENT OF ELEMENT-TRANSFORMATION EQUATION					
			$\sin^2 \alpha_0$	$\cos^2 \alpha_0$	$\sin \alpha_0 \cos \alpha_0$	$\sin \alpha_0$	$\cos \alpha_0$	1
FORCE - VELOCITY	$(F_V)$	$X_u$	$Z'_w$	$X'_u$	$X'_w + Z'_u$	0	0	0
		$X_w$	$-Z'_u$	$X'_w$	$Z'_w - X'_u$	0	0	0
		$Y_v$	0	0	0	0	0	$Y'_v$
		$Z_u$	$-X'_w$	$Z'_u$	$Z'_w - X'_u$	0	0	0
		$Z_w$	$X'_u$	$Z'_w$	$-X_w - Z_u$	0	0	0
FORCE - ROTARY	$(F_\omega)$	$X_q$	0	0	0	$Z'_q$	$X'_q$	0
		$Y_p$	0	0	0	$Y'_r$	$Y'_p$	0
		$Y_r$	0	0	0	$-Y'_p$	$Y'_r$	0
		$Z_q$	0	0	0	$-X'_q$	$Z'_q$	0
FORCE - CONTROL	$(F_\delta)$	$X_{\delta_a}$	0	0	0	$Z'_{\delta_e}$	$X'_{\delta_e}$	0
		$Y_{\delta_a}$	0	0	0	0	0	$Y'_{\delta_a}$
		$Y_{\delta_r}$	0	0	0	0	0	$Y'_{\delta_r}$
		$Z_{\delta_e}$	0	0	0	$-X'_{\delta_e}$	$Z'_{\delta_e}$	0
MOMENT - VELOCITY	$(G_V)$	$L_v$	0	0	0	$N'_v$	$L'_v$	0
		$M_u$	0	0	0	$M'_w$	$M'_u$	0
		$M_w$	0	0	0	$-M'_u$	$M'_w$	0
		$N_v$	0	0	0	$-L'_v$	$N'_v$	0
MOMENT - ROTARY	$(G_\omega)$	$L_p$	$N'_r$	$L'_p$	$L'_r + N'_p$	0	0	0
		$L_r$	$-N'_p$	$L'_r$	$N'_r - L'_p$	0	0	0
		$M_q$	0	0	0	0	0	$M'_q$
		$N_p$	$-L'_r$	$N'_p$	$N'_r - L'_p$	0	0	0
		$N_r$	$L'_p$	$N'_r$	$-L'_r - N'_p$	0	0	0
MOMENT - CONTROL	$(G_\delta)$	$L_{\delta_a}$	0	0	0	$N'_{\delta_a}$	$L'_{\delta_a}$	0
		$L_{\delta_r}$	0	0	0	$N'_{\delta_r}$	$L'_{\delta_a}$	0
		$M_{\delta_e}$	0	0	0	0	0	$M'_{\delta_e}$
		$N_{\delta_a}$	0	0	0	$-L'_{\delta_a}$	$N'_{\delta_a}$	0
		$N_{\delta_r}$	0	0	0	$-L'_{\delta_r}$	$N'_{\delta_r}$	0

$\alpha_0$  is positive as shown on page 32

TABLE 10  
VECTOR TRANSFORMATION MATRICES  
WIND-TUNNEL AXES TO WIND-TUNNEL STABILITY AXES TO VEHICLE STABILITY AXES

WIND-TUNNEL AXES TO WIND-TUNNEL STAB. AXES		VECTOR COMPONENTS - WIND-TUNNEL AXES		
		$X_w$	$Y_w$	$Z_w$
VECTOR COMPONENTS WIND-TUNNEL STABILITY AXES	$X_{wt}$	$\cos \psi$	$\sin \psi$	0
	$Y_{wt}$	$-\sin \psi$	$\cos \psi$	0
	$Z_{wt}$	0	0	1
WIND-TUNNEL STAB. AXES TO VEHICLE STABILITY AXES		VECTOR COMPONENTS - WIND-TUNNEL STAB. AXES		
		$X_{wt}$	$Y_{wt}$	$Z_{wt}$
VECTOR COMPONENTS VEHICLE STABILITY AXES	$X_s$	$\cos \zeta$	0	$-\sin \zeta$
	$Y_s$	0	1	0
	$Z_s$	$\sin \zeta$	0	$\cos \zeta$

The relations between wind-tunnel axes and vehicle axes (*stability* and *body*) are illustrated in following figure Table 10 gives the vector transformation matrices in tabular form.

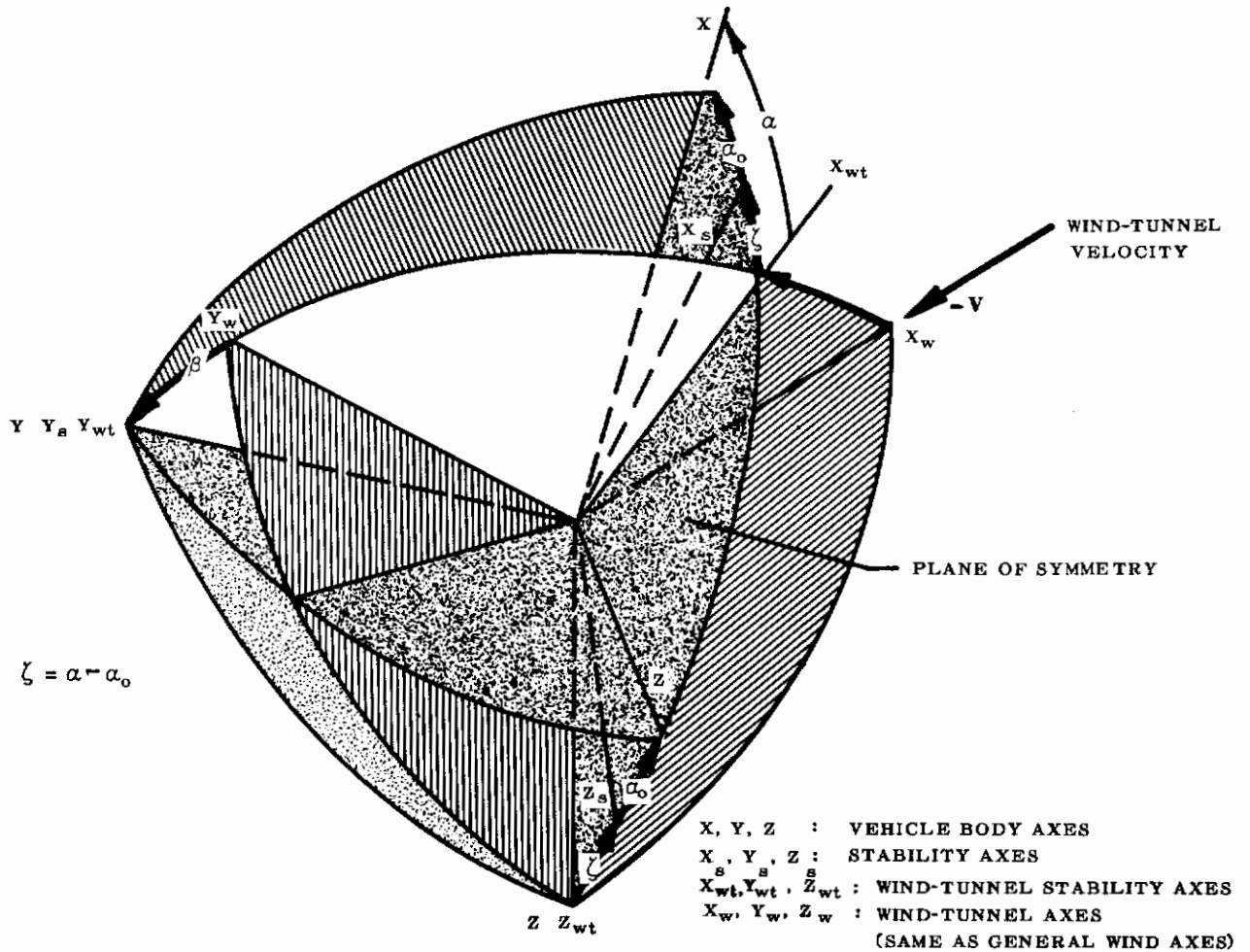

FIGURE 18 ROTATION FROM WIND-TUNNEL TO VEHICLE AXES—YAW-PITCH SEQUENCE

## 2. MULTIPLE ROTATION

There are several transformations used in the analysis of vehicle motion that involve multiple rotations of an axis system. Transformations are given in this Section that facilitate the changing of vector components between *earth* and *body axes* and between *wind* and *body axes*. The relations between these axis systems define the orientation of a vehicle with respect to the earth and the relative velocity or flight path.

The axes and notation used are defined in Section 2, and the specific vector transformation matrices are obtained from the general cases in table 2.

Only transformations for vector components are included in this Section. As is noted previously, *earth* and *wind axes* are not convenient reference axes for rigid-body motion analysis. This results from the fact that the inertia parameters become unnecessarily complex functions of time and the orientation angles (see page 16).

*Earth axes* are used primarily as a reference for the gravity force and the description of vehicle motion over a long period of time. The orientation angles between moving *earth axes* and *body axes* are defined on page 11 and are shown in figure 19. The rotation sequence corresponds to Case 1 of table 2. Hence the vector transformation matrix is obtained by substitution of  $\psi = \Psi$ ,  $\theta_1 = \Theta$ , and  $\phi_2 = \Phi$  in the matrix for Case 1. In the angular-velocity relations the *body-axis* notation, P, Q, and R, is used instead of  $\dot{\phi}_3$ ,  $\dot{\theta}_3$ , and  $\dot{\psi}_1$ , respectively.

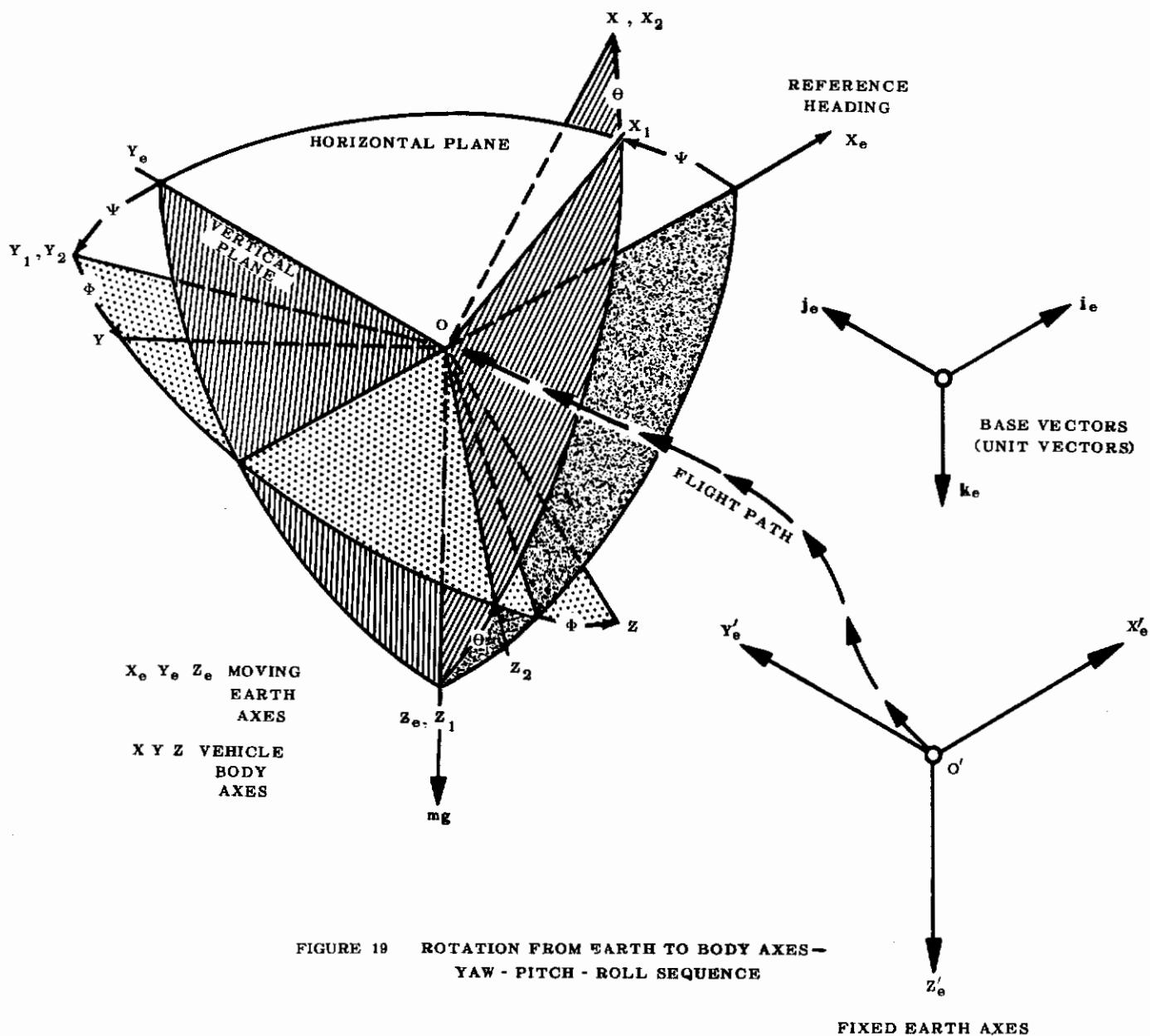

FIGURE 19 ROTATION FROM EARTH TO BODY AXES—  
YAW - PITCH - ROLL SEQUENCE

TABLE 11  
VECTOR TRANSFORMATION MATRIX  
EARTH TO BODY AXES

		COMPONENTS ALONG EARTH AXES		
		$X_e$	$Y_e$	$Z_e$
BODY AXES COMPONENTS	X	$\cos \theta \cos \psi$	$\cos \theta \sin \psi$	$-\sin \theta$
	Y	$\sin \phi \sin \theta \cos \psi$ $-\cos \phi \sin \psi$	$\sin \phi \sin \theta \sin \psi$ $+\cos \phi \cos \psi$	$\sin \phi \cos \theta$
	Z	$\cos \phi \sin \theta \cos \psi$ $+\sin \phi \sin \psi$	$\cos \phi \sin \theta \sin \psi$ $-\sin \phi \cos \psi$	$\cos \phi \cos \theta$



TABLE 12

ANGULAR-VELOCITY RELATIONS  
EARTH TO BODY AXES

$P = \dot{\phi} - \dot{\psi} \sin \theta$	$\dot{\psi} = Q \sin \phi \sec \theta + R \cos \phi \sec \theta$
$Q = \dot{\theta} \cos \phi + \dot{\psi} \sin \phi \cos \theta$	$\dot{\theta} = Q \cos \phi - R \sin \phi$
$R = -\dot{\theta} \sin \phi + \dot{\psi} \cos \phi \cos \theta$	$\dot{\phi} = P + Q \sin \phi \tan \theta + R \cos \phi \tan \theta$

General Wind Axes to Body Axes

General *wind axes* are oriented with respect to the relative wind. The orientation angles relating general *wind axes* to vehicle *body axes* are therefore convenient variables to use in expressing the aerodynamic characteristics of a vehicle. General *wind axes* are defined in figure 8. The yaw-pitch definition, the preferred definition, of angle of attack  $\alpha$  and sideslip angle  $\beta$  is illustrated in figure 20. The pitch-yaw sequence is illustrated in figure 21. Vector transformation matrices corresponding to these definitions are given in tables 13 and 15, respectively. The angular-velocity relations are given in tables 14 and 16, respectively.

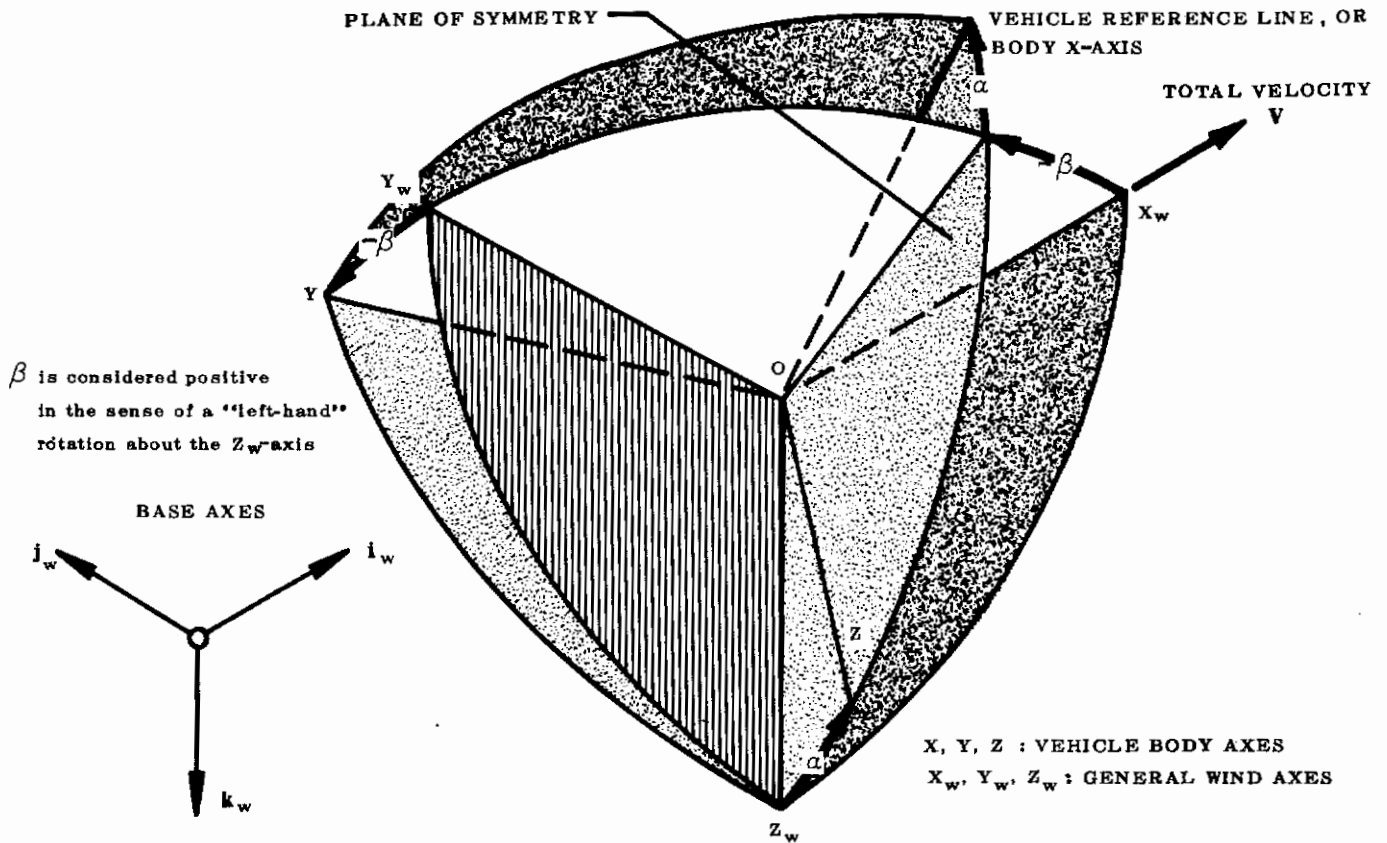

FIGURE 20 ROTATION FROM WIND TO BODY AXES — YAW - PITCH SEQUENCE

TABLE 13

VECTOR TRANSFORMATION MATRIX  
GENERAL WIND TO BODY AXES

		COMPONENTS ALONG WIND AXES		
		$X_w$	$Y_w$	$Z_w$
BODY AXES COMPONENTS	X	$\cos \alpha \cos \beta$	$-\cos \alpha \sin \beta$	$-\sin \alpha$
	Y	$\sin \beta$	$\cos \beta$	0
	Z	$\sin \alpha \cos \beta$	$-\sin \alpha \sin \beta$	$\cos \alpha$

TABLE 14

ANGULAR-VELOCITY RELATIONS  
GENERAL WIND TO BODY AXES

$P = \dot{\beta} \sin \alpha$ $Q = \dot{\alpha}$ $R = -\dot{\beta} \cos \alpha$	$\dot{\beta} = -R \sec \alpha = P \csc \alpha$ $\dot{\alpha} = Q$ $0 = P + R \tan \alpha$
---	---

Note: The above matrix and equations result from substitution of  $-\beta$ ,  $\alpha$ , and 0 for  $\psi$ ,  $\theta$ , and  $\phi$ , respectively, in Case 1 of Table 2

TABLE 15

VECTOR TRANSFORMATION MATRIX  
GENERAL WIND TO BODY AXES

		COMPONENTS ALONG WIND AXES		
		$X_w$	$Y_w$	$Z_w$
BODY AXES COMPONENTS	X	$\cos \tilde{\alpha} \cos \tilde{\beta}$	$-\sin \tilde{\beta}$	$-\sin \tilde{\alpha} \cos \tilde{\beta}$
	Y	$\cos \tilde{\alpha} \sin \tilde{\beta}$	$\cos \tilde{\beta}$	$-\sin \tilde{\alpha} \sin \tilde{\beta}$
	Z	$\sin \tilde{\alpha}$	0	$\cos \tilde{\alpha}$

TABLE 16

ANGULAR-VELOCITY RELATIONS  
GENERAL WIND TO BODY AXES

$P = -\dot{\tilde{\alpha}} \sin \tilde{\beta}$ $Q = \dot{\tilde{\alpha}} \cos \tilde{\beta}$ $R = -\dot{\tilde{\beta}}$	$\dot{\tilde{\alpha}} = Q \sec \tilde{\beta} = -P \csc \tilde{\beta}$ $\dot{\tilde{\beta}} = -R$ $0 = P + Q \tan \tilde{\beta}$
---	---

Note: The above matrix and equations result from substitution of  $\tilde{\alpha}$ ,  $-\tilde{\beta}$ , and 0, respectively, for  $\theta$ ,  $\psi$ , and  $\phi_2$ , respectively, in Case 4 of table 2.

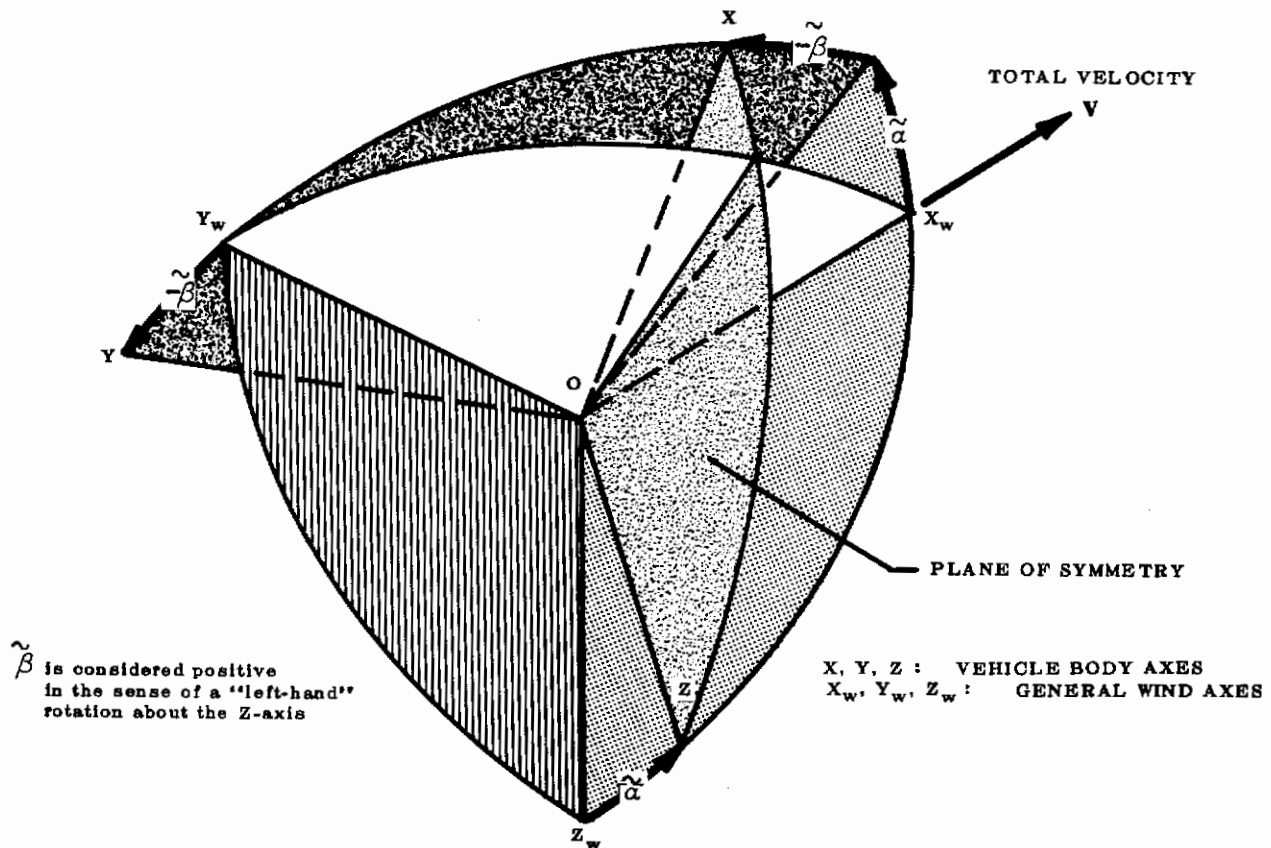

FIGURE 21 ROTATION FROM WIND TO BODY AXES—PITCH - YAW SEQUENCE

## SECTION 4. REAL FORCES AND MOMENTS\*

The preceding Sections contain equations of motion and transformations useful in the analysis of particle and rigid-body motion. Real force and moment components are indicated in these equations by a general notation for forces and moments. In the following Section the force and moment components are presented more specifically. The general component expressions are expanded to show contributions of gravity, aerodynamic force, and direct thrust force. Aerodynamic force and moment components are then further expanded for the case of small disturbances.

Stability derivatives for airplane-type vehicles are summarized.

### GENERAL FORCE AND MOMENT DESCRIPTION

The particular flight path or motion of a rigid body is the result of the external forces and moments that are applied. Thus the applied forces and moments may be considered as the "driving functions" to be used with the equations of motion of the vehicle. Solution of these equations then provides the motion or response of the vehicle to the applied forces and moments. Inversely, the problem may be formulated to find the force and moment input required to accomplish a specified motion.

The real forces and moments involved in the motion of a body through the atmosphere, in the gravitational field of the earth, may be separated into contributions of gravity, aerodynamic force, and direct thrust. In the case of particle motion, moments about the center of mass are zero, and only the force vectors need to be considered.

Components of the external force and moment vectors are usually resolved along vehicle *body axes*. Relations transforming these vector components to the *body axis* system, or any other desired reference axis system, may be obtained directly or derived from the preceding Section.

Separation of the force and moment vectors into gravity, aerodynamic, and direct thrust contributions is outlined below. For illustrative purposes the general force vector  $\mathbf{F}$  and general moment vector  $\mathbf{G}$  are resolved into components along vehicle *body axes*. *Body axes* are usually the most convenient reference axes.

The general vectors are resolved into components along the reference axes.

Thus

$$\left. \begin{aligned} \mathbf{F} &= F_x \mathbf{i} + F_y \mathbf{j} + F_z \mathbf{k} \\ \mathbf{G} &= G_x \mathbf{i} + G_y \mathbf{j} + G_z \mathbf{k} \end{aligned} \right\} \quad (31)$$

Separation of the several components into gravity, aerodynamic, and direct thrust contributions results in the following equations:

$$\left. \begin{aligned} F_x &= X_g + X + X_T \\ F_y &= Y_g + Y + Y_T \\ F_z &= Z_g + Z + Z_T \end{aligned} \right\} \quad (32)$$

$$\left. \begin{aligned} G_x &= L_g + L + L_T \\ G_y &= M_g + M + M_T \\ G_z &= N_g + N + N_T \end{aligned} \right\} \quad (33)$$

where

$X_g, Y_g, Z_g$  are components of gravity force along reference axes

$L_g, M_g, N_g$  are moment components about reference axes due to gravity force. (These are usually zero.)

\* The term "real" is used to designate noninertial forces and moments. Thus the apparent forces such as centrifugal force or Coriolis force are excluded. Gravitational or electromagnetic forces, propulsive system thrust, and aerodynamic force are examples of "real" forces.

$X, Y, Z$  are components of aerodynamic force along reference axes  
 $L, M, N$  are moment components about reference axes due to aerodynamic force  
 $X_T, Y_T, Z_T$  are components of direct thrust force along reference axes  
 $L_T, M_T, N_T$  are moment components about reference axes due to direct thrust force  
 Note:  $Y_T, L_T,$  and  $N_T$  are usually zero because of vehicle symmetry.

## GRAVITY-FORCE COMPONENTS

The gravitational force upon a vehicle is most naturally given in terms of *earth axes*. With respect to earth axes the gravity vector  $mg$  is directed along the  $Z_e$ -axis (page 10). Components along vehicle *body axes* are readily obtained by using the transformation given in table 11. The gravity-force components are then

$$\left. \begin{aligned} X_g &= -mg \sin \Theta \\ Y_g &= mg \cos \Theta \sin \Phi \\ Z_g &= mg \cos \Theta \cos \Phi \end{aligned} \right\} \quad (34)$$

along the vehicle *body axes*  $X, Y,$  and  $Z,$  respectively.

There are no moments resulting from the gravity force when the origin coincides with the vehicle center of gravity. However, if the origin is displaced from the center of gravity, the same transformation (table 11) may be applied to the components of the gravitational moment about the origin to obtain  $L_g, M_g,$  and  $N_g$ .

The components of gravitational force upon the vehicle are functions of the vehicle pitch and roll attitudes only. Heading angle does not affect the resolution of the gravity force to *body axes*.

## AERODYNAMIC FORCES AND MOMENTS

The contributions of aerodynamic force to the general force and moment vector components are outlined in this Section. These components are referred to vehicle *body axes* (Section 2, pages 11 and 12) and aircraft terminology and notation are used. Lift and drag forces are thus introduced and transformed to the *body axis* system. The general form for expansion of aerodynamic terms for small disturbances is included in this Section also.

It is convenient to use dimensionless coefficients to describe the behavior of aerodynamic forces and moments. These coefficients, defined according to established usage, are discussed and analyzed in aerodynamic texts and in reference 13. The aerodynamic parameters and their derivatives should be evaluated from experimental data, i.e., wind-tunnel or flight-test data, or estimated from the appropriate data given in reference 13 or a similar source. Mach number and Reynolds number effects upon aerodynamic parameters are assumed to be included.

Induced effects of the propulsive system are assumed to be included in the aerodynamic coefficients, since these effects are normally included in complete-model wind-tunnel data. Direct thrust forces and moments are discussed later, on page 50.

Aerodynamic coefficients depend upon the orientation of the relative wind or velocity vector with respect to the body. The angles of attack  $\alpha$  and sideslip  $\beta$  which define this orientation, are thus convenient independent variables for expressing the variations of the aerodynamic characteristics of a body. These angles also determine the velocity components  $U, V,$  and  $W$  along the vehicle reference axes  $X, Y,$  and  $Z,$  respectively.

The angles of attack and sideslip are shown in figure 22 with the velocity components along the reference axes. Both the yaw-pitch rotation ( $\alpha, \beta$ ) and the pitch-yaw rotation ( $\tilde{\alpha}, \tilde{\beta}$ ) are given; however, the former is the preferred rotation. The relations for the velocity components  $U, V,$  and  $W$  follow directly from the transformations from *general wind axes* to vehicle *body axes* in tables 13, 14, 15, and 16.

# Contrails

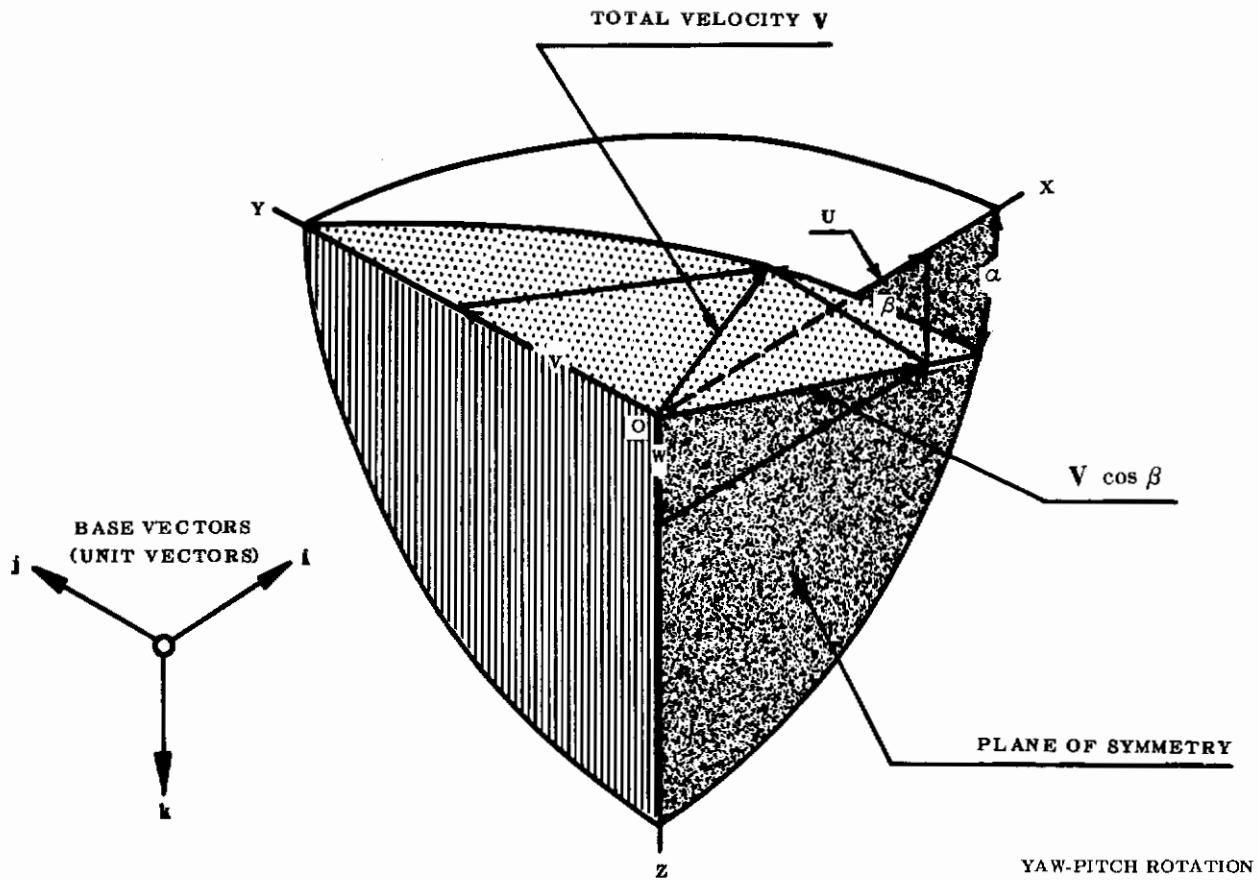

YAW-PITCH ROTATION

$$\alpha = \tan^{-1} \frac{W}{U}$$

$$\beta = \sin^{-1} \frac{V}{V}$$

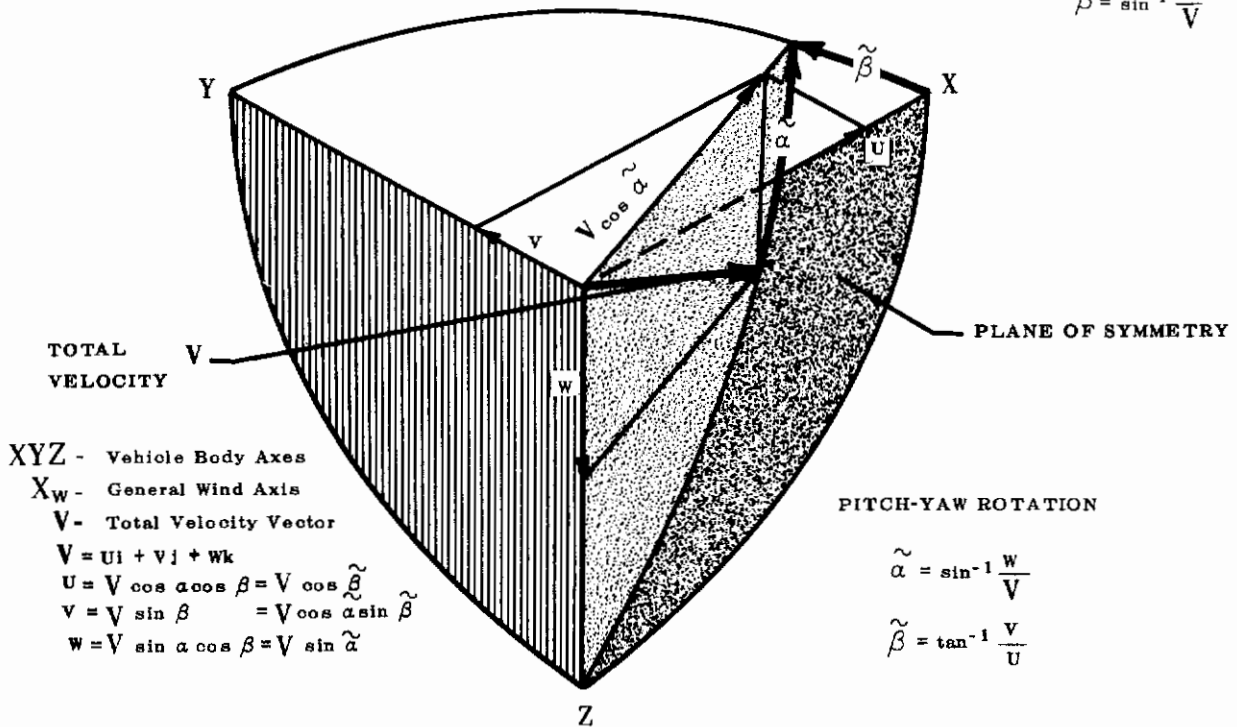

FIGURE 22 ANGLES OF ATTACK AND SIDESLIP

# Contrails

The resolution of the total aerodynamic force in the vehicle plane of symmetry is shown in figure 23. Lift,  $L$ , and drag,  $D$ , are the familiar aerodynamic forces normal and parallel, respectively, to  $V \cos \beta$ , the component of the total velocity in the vehicle plane of symmetry. Alternatively, lift and drag may be defined as the aerodynamic force components in the plane of symmetry along "instantaneous" *stability axes*, *symmetric wind axes*, or *wind-tunnel stability axes*. It should be noted that lift and drag are defined to be positive as illustrated. Thus these quantities have a negative sense with respect to the usual vehicle axis systems.

The relations for the aerodynamic force components along *body axes* are included with figure 23. These equations may be obtained directly from this figure or from the vector transformation from *stability axes* to *body axes* (table 6).

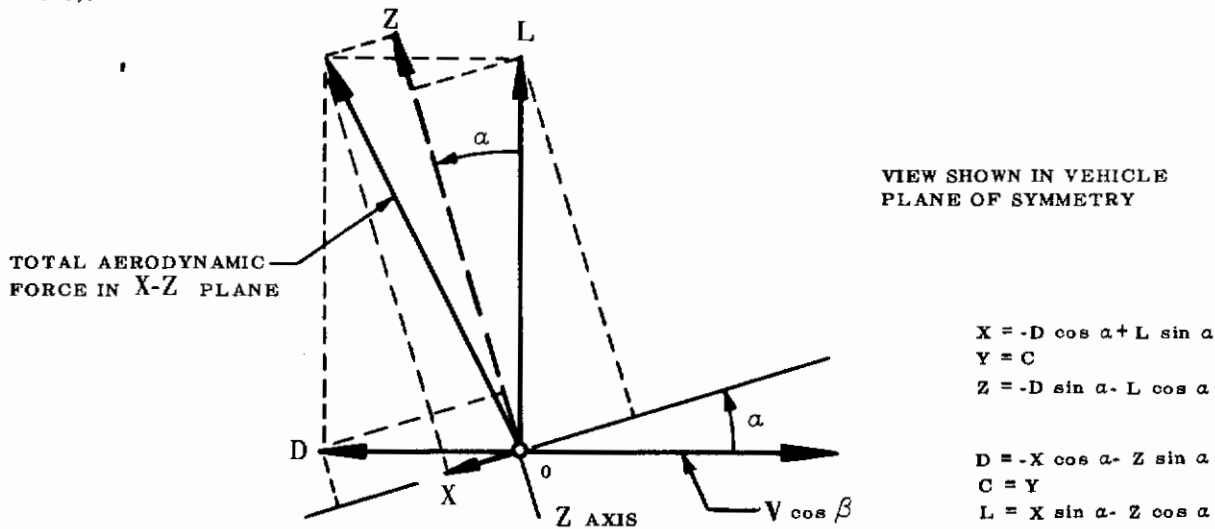

FIGURE 23 AERODYNAMIC-FORCE RESOLUTION

Aerodynamic forces and moments are usually given in terms of basic aerodynamic coefficients. These coefficients are defined by the following relations:

$L^* = C_L q S$	lift force	$L^* = C_l q S b$	rolling moment about X-axis
$D = C_D q S$	drag force	$M = C_m q S c$	pitching moment about Y-axis
$C = C_C q S$	cross-wind force	$N = C_n q S b$	yawing moment about Z-axis
$X = C_X q S$	aerodynamic force along X-axis		
$Y = C_Y q S$	aerodynamic force along Y-axis		
$Z = C_Z q S$	aerodynamic force along Z-axis		

where the quantities in the above expressions are defined as follows:

$C_L, C_D, C_C, C_X, C_Y, C_Z$	aerodynamic force coefficients	$V$	total velocity
$C_l, C_m, C_n$	moment coefficients	$S$	reference area (usually wing area)
$q = \frac{\rho V^2}{2}$	dynamic pressure	$b$	reference length (usually wing span)
$\rho$	atmospheric density	$c$	reference length (usually wing M.A.C.)

The force coefficients  $C_X$ ,  $C_Y$ , and  $C_Z$  are expressed in terms of lift, drag, and cross-wind coefficients by the same equations that relate the forces in figure 23. Thus

\* Duplication of the symbol  $L$  for lift and rolling moment has persisted throughout the aircraft industry since early times. However, since coefficients are usually used, this ambiguity is avoided by taking  $L$  as the subscript in the lift coefficient and  $l$  as the subscript in the rolling-moment coefficient.

# Contrails

$$\left. \begin{aligned}
 C_X &= C_L \sin \alpha - C_D \cos \alpha \\
 C_Y &= C_C \\
 C_Z &= -C_L \cos \alpha - C_D \sin \alpha
 \end{aligned} \right\} \text{and} \left. \begin{aligned}
 C_D &= -C_X \cos \alpha - C_Z \sin \alpha \\
 C_C &= C_Y \\
 C_L &= C_X \sin \alpha - C_Z \cos \alpha
 \end{aligned} \right\} \quad (35)$$

The moment components, as treated in this Section, are defined with respect to the *body axis* system and as such may be used directly. However, it should be noted that moments and moment coefficients may be defined with respect to *stability* or *wind-tunnel axes* and that in these cases the appropriate transformation from Section 3 must be used to obtain the desired aerodynamic moment components.

A word of caution is in order concerning the transformation of moment coefficients. The reference lengths and areas used in defining the moment coefficients may be different and, if so, this difference must be accounted for in the transformation of the moment coefficients from one axis system to another. Thus, although the transformation is appropriate for the vector components, it does not directly transform these components when expressed in coefficient form. Another important item relative to moment coefficients is the location of the moment reference center. In any particular case this must be checked to assure that the moment-of-inertia and product-of-inertia terms on the right side of the equations of motion, e.g., equation 9, are consistent with the center of reference for the external moments.

The aerodynamic forces and moments are involved functions of many variables. Test data are the best source of aerodynamic force and moment characteristics; however, in many instances a particular configuration may be in the preliminary design stage and test data may not yet be available. When it is required to estimate aerodynamic characteristics of a configuration, data and techniques such as those contained in reference 13 should be used.

A summary of the major variables that affect the aerodynamic characteristics of a rigid body or a vehicle is given below.

**Velocity, temperature, and altitude:** These variables may be considered directly or indirectly as Mach numbers, Reynolds numbers, and dynamic pressures. Velocity may be resolved into components U, V, and W along the vehicle reference axes.

**Angles of attack and sideslip:** Angle of attack  $\alpha$  and angle of sideslip  $\beta$  may be used with the magnitude of the total velocity  $V$  to express the orthogonal velocity components U, V, and W. It is more convenient to express variation of force and moment characteristics with these angles as independent variables rather than the velocity components.

**Angular velocity:** The angular velocity is usually resolved into components P, Q, and R about the vehicle reference axes.

**Control-surface deflection:** Control surfaces are used primarily to change or balance aerodynamic forces and moments.

Since the above variables are identified with a steady motion, the variation of aerodynamic forces and moments with time is assumed to be negligible. As is noted in references 4, 11, and 14, this assumption is reasonable for most problems in analysis of vehicle motion in the atmosphere. However, aerodynamic forces and moments are the result of the pressure of the air exerted on the body and this pressure depends upon the flow field about the body. Because air has mass, the flow field cannot adjust instantaneously to sudden changes in these variables, and transient conditions exist. In some cases, these transient effects become significant. Analysis of certain unsteady motions may therefore require consideration of the time derivatives of the variables listed above.

Two typical functional-dependence relations for the aerodynamic force component along the body X-axis are expressed below. Similar expressions for Y and Z force components and the aerodynamic moment components L, M and N could be written:

$$\left. \begin{aligned}
 X &= X_1 (U, V, W, \dot{U}, \dot{V}, \dot{W}, \dots, P, Q, R, \dot{P}, \dot{Q}, \dot{R}, \dots, \delta_a, \delta_e, \delta_r, \dot{\delta}_a, \dot{\delta}_e, \dot{\delta}_r, \dots, \rho, M, R, \dots) \\
 &= X_2 (V, \alpha, \beta, \dot{V}, \dot{\alpha}, \dot{\beta}, \dots, P, Q, R, \dot{P}, \dot{Q}, \dot{R}, \dots, \delta_a, \delta_e, \delta_r, \dot{\delta}_a, \dot{\delta}_e, \dot{\delta}_r, \dots, \rho, M, R, \dots)
 \end{aligned} \right\} \quad (36)$$

M=MACH NUMBER

R=REYNOLDS NUMBER



It is apparent that in the practical case of solving engineering problems much simplification of the above functional relations is required. Fortunately, it is possible to make certain assumptions that simplify the mathematics considerably, while still permitting solutions of practical significance. Expansion of the aerodynamic components for small disturbances is illustrated in subsequent paragraphs, and the simplifications of the equations of motion for practical solutions are discussed in Section 5.

There are many cases of practical interest in the analysis of aircraft motion in which the disturbance from a steady-flight condition is small. In these cases it is permissible and convenient to express the aerodynamic force and moment components in a Taylor series expansion. This expansion is formed in terms of perturbations from a reference steady-flight condition. The use of the expansion is limited to problems where the perturbations are small and where the second- and higher-order derivatives of the variable quantities and the products of the perturbation quantities are therefore negligible. Thus they may be omitted in the simplified expressions for the aerodynamic force and moment components. Of course, this type of expansion requires the first derivatives of the aerodynamic force and moment components with respect to the aerodynamic variables that affect these forces and moments. These derivatives, commonly referred to as "stability derivatives," will be discussed in detail later.

The general procedure for expanding the aerodynamic force and moment relations for small disturbances from steady flight may be found in many places in the literature, e.g., references 4 and 11. The notation for small disturbances from a reference flight condition is as follows. Lower case symbols are used to designate the perturbations of velocity and orientation variables. Upper case symbols with subscript zero are used to denote the reference values of these quantities. For example,  $U = U_0 + u$ ,  $P = P_0 + p$ , and  $\Phi = \Phi_0 + \phi$ . The incremental changes in the aerodynamic force and moment components are indicated by the prefix  $\Delta$ . Thus  $X = X_0 + \Delta X$ ,  $Y = Y_0 + \Delta Y$ ,  $M = M_0 + \Delta M$ , etc. The control deflection angles  $\delta_a$ ,  $\delta_e$ , and  $\delta_r$  are used just as they are and are interpreted as the control perturbation angles from the steady-state trimmed-flight condition. To illustrate the general expansion of the aerodynamic force component along the body X-axis the first functional relation for X on page 47 may be expressed as follows:

$$\left. \begin{aligned}
 X = X_0 + \Delta X = X_0 + X_{uu}u + X_{vv}v + X_{ww}w + X_{\dot{u}}\dot{u} + X_{\dot{v}}\dot{v} + X_{\dot{w}}\dot{w} + \dots + \\
 X_{pp}p + X_{qq}q + X_{rr}r + X_{\dot{p}}\dot{p} + X_{\dot{q}}\dot{q} + X_{\dot{r}}\dot{r} \dots + X_{\delta_a} \delta_a + \\
 X_{\delta_e} \delta_e + X_{\delta_r} \delta_r + X_{\dot{\delta}_a} \dot{\delta}_a + \dots + (\text{higher order terms})^*
 \end{aligned} \right\} \quad (37)$$

where  $X_u = \partial X / \partial u$ , etc.

Variables may be added to represent additional aerodynamic effects such as occur in higher order unsteady aerodynamics.

---

\* Just the second-order terms in the expansion would require a page or more to write out. The expansion would have the following form:

$$\begin{aligned}
 & 1/2 [(X_{uu}u^2 + X_{vv}v^2 + \dots + X_{\dot{u}\dot{u}}\dot{u}^2 + \dots + X_{pp}p^2 + \dots + X_{\dot{p}\dot{p}}\dot{p}^2 + \dots + \\
 & X_{\delta_e\delta_e}\delta_e^2 + \dots + X_{\dot{\delta}_e\dot{\delta}_e}\dot{\delta}_e^2 + \dots) + 2(X_{uv}uv + \dots + X_{v\dot{u}}v\dot{u} + \dots + \\
 & X_{vp}pv + \dots + X_{v\dot{p}}v\dot{p} + \dots + X_{v\delta_e}\delta_e v + \dots + X_{v\dot{\delta}_e}\dot{\delta}_e v + \dots) + \\
 & 2(X_w\dot{u}w + \dots + X_{wp}pw + \dots + X_{w\dot{p}}w\dot{p} + \dots + X_{w\delta_e}\delta_e w + \dots) + \\
 & 2(X_{\dot{u}\dot{v}}\dot{u}\dot{v} + \dots + X_{\dot{p}\dot{p}}\dot{p}\dot{p} + \dots) + \dots + 2(X_{\delta_e\delta_e}\delta_e\delta_e + \dots +) + \dots]
 \end{aligned}$$

**TABLE 17**  
**AERODYNAMIC FORCE AND MOMENT INCREMENTS**  
**FOR SMALL DISTURBANCES**  
 (Components Along Vehicle Axes)

DISTURBANCE VARIABLES		Force Components			Moment Components		
		$\Delta X$	$\Delta Y$	$\Delta Z$	$\Delta L$	$\Delta M$	$\Delta N$
Linear Velocity Components	u	$X_u$	$Y_u^*$	$Z_u$	$L_u^*$	$M_u$	$N_u^*$
	v	$X_v^{**}$	$Y_v$	$Z_v^{**}$	$L_v$	$M_v^{**}$	$N_v$
	w	$X_w$	$Y_w^*$	$Z_w$	$L_w^*$	$M_w$	$N_w^*$
Linear Acceleration Components	$\dot{u}$	$X_{\dot{u}}^{***}$	$Y_{\dot{u}}^*$	$Z_{\dot{u}}^{***}$	$L_{\dot{u}}^*$	$M_{\dot{u}}^{***}$	$N_{\dot{u}}^*$
	$\dot{v}$	$X_{\dot{v}}^{**}$	$Y_{\dot{v}}^{***}$	$Z_{\dot{v}}^{**}$	$L_{\dot{v}}$	$M_{\dot{v}}^{**}$	$N_{\dot{v}}$
	$\dot{w}$	$X_{\dot{w}}^{***}$	$Y_{\dot{w}}^*$	$Z_{\dot{w}}^{***}$	$L_{\dot{w}}^*$	$M_{\dot{w}}$	$N_{\dot{w}}^*$
Angular Velocity Components	p	$X_p^{**}$	$Y_p$	$Z_p^{**}$	$L_p$	$M_p^{**}$	$N_p$
	q	$X_q^{***}$	$Y_q^*$	$Z_q^{***}$	$L_q^*$	$M_q$	$N_q^*$
	r	$X_r^{**}$	$Y_r$	$Z_r^{**}$	$L_r$	$M_r^{**}$	$N_r$
Angular Acceleration Components	$\dot{p}$	$X_{\dot{p}}^{**}$	$Y_{\dot{p}}^{***}$	$Z_{\dot{p}}^{**}$	$L_{\dot{p}}^{***}$	$M_{\dot{p}}^{**}$	$N_{\dot{p}}^{***}$
	$\dot{q}$	$X_{\dot{q}}^{***}$	$Y_{\dot{q}}^*$	$Z_{\dot{q}}^{***}$	$L_{\dot{q}}^*$	$M_{\dot{q}}^{***}$	$N_{\dot{q}}^*$
	$\dot{r}$	$X_{\dot{r}}^{**}$	$Y_{\dot{r}}^{***}$	$Z_{\dot{r}}^{**}$	$L_{\dot{r}}^{***}$	$M_{\dot{r}}^{**}$	$N_{\dot{r}}^{***}$
Control Deflection	$\delta_a$	$X_{\delta_a}^{**}$	$Y_{\delta_a}^*$	$Z_{\delta_a}^{**}$	$L_{\delta_a}^*$	$M_{\delta_a}^{**}$	$N_{\delta_a}^*$
	$\delta_e$	$X_{\delta_e}^{***}$	$Y_{\delta_e}^*$	$Z_{\delta_e}^{***}$	$L_{\delta_e}^*$	$M_{\delta_e}^{***}$	$N_{\delta_e}^*$
	$\delta_r$	$X_{\delta_r}^{**}$	$Y_{\delta_r}^*$	$Z_{\delta_r}^{**}$	$L_{\delta_r}^*$	$M_{\delta_r}^{**}$	$N_{\delta_r}^*$
Control Deflection Rates	$\dot{\delta}_a$	$X_{\dot{\delta}_a}^{***}$	$Y_{\dot{\delta}_a}^{***}$	$Z_{\dot{\delta}_a}^{***}$	$L_{\dot{\delta}_a}^{***}$	$M_{\dot{\delta}_a}^{**}$	$N_{\dot{\delta}_a}^{***}$
	$\dot{\delta}_e$	$X_{\dot{\delta}_e}^{***}$	$Y_{\dot{\delta}_e}^*$	$Z_{\dot{\delta}_e}^{***}$	$L_{\dot{\delta}_e}^*$	$M_{\dot{\delta}_e}^{***}$	$N_{\dot{\delta}_e}^*$
	$\dot{\delta}_r$	$X_{\dot{\delta}_r}^{**}$	$Y_{\dot{\delta}_r}^{***}$	$Z_{\dot{\delta}_r}^{**}$	$L_{\dot{\delta}_r}^{***}$	$M_{\dot{\delta}_r}^{**}$	$N_{\dot{\delta}_r}^{***}$

- \* Asymmetric force and moment component derivatives with respect to symmetric disturbance variables.
- \*\* Symmetric force and moment component derivatives with respect to asymmetric disturbance variables. (Both sets of terms are identically zero for disturbances from a state of steady symmetric motion, i.e., V, P, R, and their derivatives are all zero, of an aircraft with an XZ-plane of symmetry.)
- \*\*\* Terms that are usually negligible.

## THRUST FORCES AND MOMENTS

The propulsive system of a vehicle generally produces both a direct thrust force and indirect or induced effects upon the aerodynamic forces. These contributions of the propulsive system to the force and moment components are presented and discussed in reference 13.

Direct thrust force and moment components should be used in accordance with the force-moment component resolution of equations 32 and 33 on page 44, i.e.,  $X_T$ ,  $Y_T$ ,  $Z_T$ ,  $L_T$ ,  $M_T$ , and  $N_T$ . These components may be developed directly from the geometric relation between the direct-thrust line of action and the moment reference center of the vehicle.

Induced-thrust and propulsive-system effects are conveniently included in the aerodynamic components. Wind-tunnel and flight-test aerodynamic data usually include the indirect effects of the jet flow or running propellers upon the aerodynamic characteristics of a vehicle configuration. Methods for estimating these induced propulsive-system effects are included in reference 13.

## STABILITY DERIVATIVES

The partial derivatives that occur in the expansion of aerodynamic force and moment components are commonly referred to as "Stability Derivatives." These quantities are useful in general and most applicable in the analysis of small-disturbance motions from a steady reference flight condition. In this Section the derivatives and notation are defined.

Several systems of notation and definition for stability derivatives and/or parameters have been developed and are found in the literature. The reader should be forewarned and reminded to be thorough and alert when using published works — including the present report — to check the notation and definitions used (see page 129 of reference 4 or page IV-2 of reference 11). The notation in this report is selected to be consistent, insofar as possible, with that used by NASA and in references 3 and 4.

A summary of the stability derivatives and notation used in vehicle stability and control analysis is presented in this Section. Since symmetry of the vehicle and initial flight condition is assumed throughout, the number of derivatives is reduced, as indicated in table 17. Unusual configurations and special problems may require derivatives that are not included in this Section.

Data presented in reference 13 include general and detailed information on stability derivatives and methods for estimating values of these derivatives. Also, general and special methods and analyses for evaluation of these derivatives are found in many places in the literature. References 4, 7, and 15 are typical general references and reference 17 is a typical special investigation.

Three types of stability derivatives are used in airplane stability and control analysis. The following paragraphs discuss each type. Notation for these derivatives and other items used in connection with stability analysis are given in table 18. Table 19 contains the relationships used to define the nondimensional derivatives along body axes and expresses them in terms of stability axis derivatives. Nondimensional derivatives along stability axes are presented and identified in table 20. This is the most familiar form of the stability derivatives.

### DIMENSIONAL DERIVATIVES—BODY AXES

The derivatives used in the development of small-disturbance expansions for aerodynamic force and moment relations (see page 49) were defined as dimensional derivatives. These partial derivatives of the force and moment components are taken with respect to perturbations of the significant velocity, acceleration, and control variables\*.

\* Consider the following for the case of small disturbance from a steady flight condition:

$$\text{Let } U = U_0 + u \text{ and } P = P_0 + p$$

$$\frac{\partial X}{\partial U} = \frac{\partial X}{\partial U_0} \frac{\partial U_0}{\partial U} + \frac{\partial X}{\partial u} \frac{\partial u}{\partial U} = \frac{\partial X}{\partial u}$$

$$\frac{\partial N}{\partial P} = \frac{\partial N}{\partial P_0} \frac{\partial P_0}{\partial P} + \frac{\partial N}{\partial p} \frac{\partial p}{\partial P} = \frac{\partial N}{\partial p}$$

since  $\frac{\partial U_0}{\partial U}$  and  $\frac{\partial P_0}{\partial P}$  are each zero and  $\frac{\partial u}{\partial U}$  and  $\frac{\partial p}{\partial P}$  each equal 1

The general notation uses upper case symbols with a subscript denoting the variable of differentiation, and body axes are specified. In this case, however, body axes may refer to any axis system fixed to the vehicle and thus include the special cases of stability and principal axes. This, at least in part, is the origin of much of the confusion in stability derivative notation. Also, it is the reason for using the prime to denote the difference between body and stability reference axes in the transformation of stability derivatives (tables 8 and 9).

Dimensional derivatives are used as elements of the matrices shown in equations 24 through 29 and in various equations throughout subsequent Sections. Some examples of these derivatives are

$$X_u = \frac{\partial X}{\partial u}; \quad M_w = \frac{\partial M}{\partial w}; \quad N_p = \frac{\partial N}{\partial p}; \quad Z_{\delta_e} = \frac{\partial Z}{\partial \delta_e}$$

The dimensional derivatives are listed in table 17, with the notation given in table 18.

## NONDIMENSIONAL DERIVATIVES – BODY AXES

The use of nondimensional equations is usually convenient when aerodynamic forces and moments are involved in a problem. Hence it is useful to define nondimensional stability derivatives along body axes. As in the preceding case, these axes may be considered as general body axes that include the stability and principal axes as special cases.

Lower case basic symbols are used to designate the nondimensional body-axis derivatives. This introduces some additional possibilities for confusion and ambiguity in the notation. For example,  $m_n'$  is a stability derivative and  $m$  without any subscript denotes the vehicle mass. Although this is not a desirable situation, ultimately it is less confusing to maintain the system of notation and be wary of the pitfalls of ambiguity in the notation than to revise the familiar and established symbols. In this instance the mass  $m$  is frequently incorporated in the parameter  $\tau$  and thus the confusion is prevented.

Several examples of the nondimensional derivatives along body axes are given below. A more nearly complete listing of these derivatives and the notation used is given in table 19. The equations relating stability-axis derivatives to the derivatives along body axes are given in this table. The relations given in table 19 also serve to transform the derivatives based upon wind-tunnel axes to stability axes ( $\alpha_0 = 0$ ).

$$x_{\alpha'} = \frac{\partial X}{\partial \alpha'} \frac{1}{q_0 S} = X_w \frac{\partial w}{\partial \alpha'} \frac{1}{q_0 S}$$

$$n_{\beta'} = \frac{\partial N}{\partial \beta'} \frac{1}{q_0 S b} = N_v \frac{\partial v}{\partial \beta'} \frac{1}{q_0 S b}$$

$$y_p = \frac{\partial Y}{\partial p} \frac{1}{q_0 S} = Y_p \frac{1}{q_0 S} = C_{Yp} \frac{b}{2V_0} *$$

$$m_{\delta_e} = \frac{\partial M}{\partial \delta_e} \frac{1}{q_0 S \bar{c}} = M_{\delta_e} \frac{1}{q_0 S \bar{c}}$$

Note that in the above examples the divisor changes and the linear velocity disturbance variables  $w$  and  $v$  are converted to nondimensional variables  $\alpha'$  and  $\beta'$ , respectively.

## NONDIMENSIONAL DERIVATIVES – STABILITY AXES

To many individuals the term "stability derivatives" means the nondimensional derivatives of aerodynamic coefficients with reference to stability axes. These are the familiar parameters  $C_{L\alpha}$ ,  $C_{n\beta}$ ,  $C_{m\dot{q}}$ , etc. that are used in aircraft stability and control analysis. Lift and drag are the Z- and X-force components. Wind-tunnel data are usually reduced to stability axes and provide experimental values for many of these stability parameters.

\* The nondimensional rotary derivatives retain the dimension of time in the case of body axes, while in the case of stability axes the nondimensional rotary velocities are used, i.e.,  $\frac{pb}{2V}$ ,  $\frac{q\dot{\epsilon}}{2V}$ ,  $\frac{r\dot{b}}{2V}$ .

There is much literature containing analytical and experimental investigations of stability derivatives and parameters. Reference 13 includes methods and reference material for evaluating these quantities. Chapter 5 of reference 4 contains a comprehensive discussion of airplane stability derivatives.

The nondimensional stability derivatives referred to stability axes are listed in table 20. The general notation used is given in table 18. These derivatives are grouped into the longitudinal stability derivatives or parameters and the lateral derivatives.

Included in table 20 are sketches of typical variations of the stability parameters with Mach number. This information was adapted from reference 16. Also included in the tabulation of nondimensional stability derivatives are some specialized parameters such as  $C_{n\beta}$  and  $C_{l\beta}$ . The effects and importance of these two derivatives are discussed in reference 18.

TABLE 18  
SYMBOLS AND NOTATION  
STABILITY DERIVATIVES AND RELATED PARAMETERS

SYMBOL	DEFINITION
b	wing span
C	(i) basic symbol for aerodynamic force and moment coefficients (ii) aerodynamic cross-wind force
$C_L, C_D$	lift and drag force coefficients, respectively, (stability axes)  $C_L = \frac{L}{qS}, C_D = \frac{D}{qS}$
$C_X, C_Y, C_Z$	longitudinal, side-force, and normal-force coefficients, respectively, (body axes)  $C_X = \frac{X}{qS}, C_Y = \frac{Y}{qS}, C_Z = \frac{Z}{qS}$
$C_l, C_m, C_n$	rolling-, pitching-, and yawing-moment coefficients, respectively  $C_l = \frac{L}{qSb}, C_m = \frac{M}{qSc}, C_n = \frac{N}{qSb}$
$C_{u\alpha}, C_{rM}, C_{n\beta}, C_{m\alpha}$ , etc.	nondimensional stability derivatives with reference to stability axes (see table 20)
$C_{IX}, C_{IY}$	moment-of-inertia coefficients and product-of-inertia coefficient
$C_{IZ}, C_{IXZ}$	$C_{IX} = \frac{I_X}{q_\infty S b} \quad C_{IY} = \frac{I_Y}{q_\infty S c}$ $C_{IZ} = \frac{I_Z}{q_\infty S b} \quad C_{IXZ} = \frac{I_{XZ}}{q_\infty S b}$
	Note: 1. The divisor of $C_{IY}$ contains $\bar{c}$ instead of b. 2. The inertia parameters must correspond to the axis system used in a particular analysis, i.e., body, stability, or principal axes.

TABLE 18 *Continued*

SYMBOL	DEFINITION
$\bar{c}$	wing mean aerodynamic chord
D	aerodynamic drag — the aerodynamic force in the plane of symmetry along the projection of the relative wind on the plane of symmetry. Drag is positive in the negative X (downstream) direction.
g	gravitational acceleration constant
H <sub>e</sub>	engine momentum, counter-clockwise viewed from rear
I <sub>X</sub> , I <sub>Y</sub> , I <sub>Z</sub>	moments of inertia about X-, Y-, and Z-axes, respectively
I <sub>XZ</sub>	product of inertia with respect to X- and Z-axes  Note: Moment-of-inertia and product-of-inertia terms must correspond to the axis system being used.
i <sub>T</sub>	incidence of thrust line with respect to XZ-plane of body reference system. Thrust incidence is positive for T sin i <sub>T</sub> acting in the negative Z (lift) direction.
L	aerodynamic lift — the aerodynamic force in the plane of symmetry perpendicular to the projection of the relative wind on the plane of symmetry. Lift is positive in the negative Z (upward) sense.
L, M, N	aerodynamic rolling-, pitching-, and yawing-moments about X-, Y-, and Z-axes, respectively  Note: Lift and rolling moment use the same symbol, L
L <sub>( )</sub> , M <sub>( )</sub> , N <sub>( )</sub>	basic symbols for dimensional moment derivatives; subscript denotes variable of differentiation (see table 17)
ΔL, ΔM, ΔN	incremental changes in aerodynamic moments used in small-disturbance analysis
ΔM <sub>T</sub>	pitching-moment component of direct thrust force  Note: When direct thrust is included in the aerodynamic or total moment, ΔM <sub>T</sub> should be deleted.
l <sub>( )</sub> , m <sub>( )</sub> , n <sub>( )</sub>	basic symbols for nondimensional moment derivatives about body axes; subscript denotes variable of differentiation (see table 19)
l <sub>a</sub> , m <sub>a</sub> , n <sub>a</sub>	direction cosines between body axes and the gravity vector
M	Mach number  Note: M is also used as pitching moment
m	mass  Note: m is also used as the basic symbol for the nondimensional pitching-moment derivatives about body axes.
P, Q, R	rolling, pitching, and yawing velocity components (angular) about X-, Y-, and Z-axes, respectively

TABLE 18 *Continued*

SYMBOL	DEFINITION
p, q, r	small-disturbance angular velocity components about X-, Y-, and Z-axes, respectively
q	dynamic pressure $q = \frac{\rho V^2}{2}$ Note: q is also used as the small-disturbance pitching velocity.
S	wing area or reference area for aerodynamic coefficients
T	net direct thrust force
$T'_c$	thrust coefficient, $T'_c = \frac{T}{qS}$
$T_V$	$\frac{\partial T}{\partial V}$
t	time
U, V, W	linear velocity components along X-, Y-, and Z-axes, respectively
u, v, w	small-disturbance linear velocity components along X-, Y-, and Z-axes, respectively
u'	small-disturbance nondimensional longitudinal velocity variable, $u' = \frac{u}{V_0}$
V	total linear velocity of vehicle c.g.
X, Y, Z	aerodynamic force components along X-, Y-, and Z-axes, respectively
$X_{(\ )}, Y_{(\ )}, Z_{(\ )}$	basic symbols for dimensional force derivative; subscript denotes variable of differentiation (see table 17). For example, $X_u = \frac{\partial X}{\partial u}; X_{\delta_e} = \frac{\partial X}{\partial \delta_e}; X_w = \frac{\partial X}{\partial w}$
$\Delta X, \Delta Y, \Delta Z$	incremental changes in aerodynamic force components used in small-disturbance analyses
$X_x, Z_x$	components of direct thrust force along X- and Z-axes, respectively  Note: When direct thrust is included in the aerodynamic force components, these terms should be deleted.
$x_{(\ )}, y_{(\ )}, z_{(\ )}$	basic symbols for nondimensional force derivatives along body axes; subscript denotes the variable of differentiation (see table 19)
$z_T$	distance parallel to Z-axis from vehicle c.g. to the projection of the thrust line in the plane of symmetry (positive for c.g. above thrust line)
$\alpha$	angle of attack (see figure 22)

TABLE 18 *Continued*

SYMBOL	DEFINITION
$\alpha'$	small-disturbance velocity variable, $\alpha' = \frac{w}{V_o}$
$\alpha_T$	angle of attack of thrust line, $\alpha_T = \alpha + i_T$
$\beta$	sideslip angle (see figure 22)
$\beta'$	small-disturbance velocity variable, $\beta' = \frac{v}{V_o}$
$\gamma$	flight-path angle, the angle between the velocity vector and the plane of the horizon
$\delta_a, \delta_e, \delta_r$	change in deflection of ailerons, elevator, and rudder, respectively
$\rho$	air density
$\tau$	time parameter, $\tau = \frac{m}{\rho S V_o} = \frac{V_o m}{2 q_o S}$
$\Psi, \Theta, \Phi$	orientation angles of vehicle body axes in yaw, pitch, roll sequence (see page 11)  Note: In some special cases using stability axes the flight-path angle $\gamma$ is used in place of the pitch orientation angle $\Theta$ . When this is done, the yaw and pitch angles, $\Psi$ and $\Phi$ , should be used as referring to stability axes also (see page 77).
$\phi, \theta, \psi$	perturbations of vehicle axes orientation angles $\Phi, \Theta, \Psi$ , respectively. In the small-disturbance approximation $\phi = \int p dt$ , $\theta = \int q dt$ , $\psi = \int r dt$ , respectively.
$\Omega_x, \Omega_y, \Omega_z$	angular velocities of wind axes; prime is used to denote small-angle approximations (see page 77).
<p>General Notes:</p> <ol style="list-style-type: none"> <li>1. All angles and angular velocities are in radian measure.</li> <li>2. Fundamental units are used throughout, i.e., slugs, feet, seconds.</li> <li>3. Throughout this table the symbol <math>q</math> denotes dynamic pressure when multiplied by the wing area (<math>qS</math>).</li> <li>4. The subscript <math>o</math> denotes steady-state reference condition for small-disturbance analyses.</li> </ol>	



TABLE 19  
 NONDIMENSIONAL STABILITY DERIVATIVES  
 (BODY AXES)

Direct thrust terms included

	Symbol	Derivative	Expanded Form in Terms of Stability Axis Derivatives
<b>Force Velocity</b>	$x_u'$	$\frac{\partial X}{\partial u'} \frac{1}{q_0 S}$	$C_{X_u} \cos^2 \alpha_0 + C_{Z_u} \sin^2 \alpha_0$ $+ (-C_{X_\alpha} - C_{Z_u}) \cos \alpha_0 \sin \alpha_0$ $+ \frac{2\tau}{m} T_V \cos i_T \cos \alpha_0$
	$x_\alpha'$	$\frac{\partial X}{\partial \alpha'} \frac{1}{q_0 S}$	$C_{X_\alpha} \cos^2 \alpha_0 - C_{Z_u} \sin^2 \alpha_0$ $+ (C_{X_u} - C_{Z_\alpha}) \cos \alpha_0 \sin \alpha_0$ $+ \frac{2\tau}{m} T_V \sin i_T \sin \alpha_0$
	$y_\beta'$	$\frac{\partial Y}{\partial \beta'} \frac{1}{q_0 S}$	$C_{Y\beta}$
	$z_u'$	$\frac{\partial Z}{\partial u'} \frac{1}{q_0 S}$	$C_{Z_u} \cos^2 \alpha_0 - C_{X_\alpha} \sin^2 \alpha_0$ $+ (C_{X_u} - C_{Z_\alpha}) \cos \alpha_0 \sin \alpha_0$ $- \frac{2\tau}{m} T_V \sin i_T \cos \alpha_0$
	$z_\alpha'$	$\frac{\partial Z}{\partial \alpha'} \frac{1}{q_0 S}$	$C_{Z_\alpha} \cos^2 \alpha_0 + C_{X_u} \sin^2 \alpha_0$ $+ (C_{X_\alpha} + C_{Z_u}) \cos \alpha_0 \sin \alpha_0$ $- \frac{2\tau}{m} T_V \sin i_T \sin \alpha_0$
<b>Force Rotary</b>	$x_q$	$\frac{\partial X}{\partial q} \frac{1}{q_0 S}$	$(C_{X_q} \cos \alpha_0 - C_{Z_q} \sin \alpha_0) \frac{\bar{c}}{2V_0}$
	$y_p$	$\frac{\partial Y}{\partial p} \frac{1}{q_0 S}$	$(C_{Y_p} \cos \alpha_0 - C_{Y_r} \sin \alpha_0) \frac{b}{2V_0}$
	$y_r$	$\frac{\partial Y}{\partial r} \frac{1}{q_0 S}$	$(C_{Y_r} \cos \alpha_0 + C_{Y_p} \sin \alpha_0) \frac{b}{2V_0}$
	$z_q$	$\frac{\partial Z}{\partial q} \frac{1}{q_0 S}$	$(C_{Z_q} \cos \alpha_0 + C_{X_q} \sin \alpha_0) \frac{\bar{c}}{2V_0}$
<b>Force Control</b>	$x_{\delta_e}$	$\frac{\partial X}{\partial \delta_e} \frac{1}{q_0 S}$	$C_{X_{\delta_e}} \cos \alpha_0 - C_{Z_{\delta_e}} \sin \alpha_0$
	$y_{\delta_a}$	$\frac{\partial Y}{\partial \delta_a} \frac{1}{q_0 S}$	$C_{Y_{\delta_a}}$
	$y_{\delta_r}$	$\frac{\partial Y}{\partial \delta_r} \frac{1}{q_0 S}$	$C_{Y_{\delta_r}}$
	$z_{\delta_e}$	$\frac{\partial Z}{\partial \delta_e} \frac{1}{q_0 S}$	$C_{Z_{\delta_e}} \cos \alpha_0 + C_{X_{\delta_e}} \sin \alpha_0$

TABLE 19 *Continued*

NONDIMENSIONAL STABILITY DERIVATIVES  
(BODY AXES)

	Symbol	Derivative	Expanded Form in Terms of Stability Axes Derivatives
<b>Moment Velocity</b>	$l_{\beta'}$	$\frac{\partial L}{\partial \beta'} \frac{1}{q_0 S b}$	$C_{l_{\beta}} \cos \alpha_0 - C_{n_{\beta}} \sin \alpha_0$
	$m_{u'}$	$\frac{\partial M}{\partial u'} \frac{1}{q_0 S \bar{c}}$	$\left[ C_{m_u} + \frac{2\tau}{m} T_V \frac{z_T}{\bar{c}} - 2 T_{c_0} \frac{z_T}{\bar{c}} \right] \cos \alpha_0$ $- C_{m_{\alpha}} \sin \alpha_0$
	$m_{\alpha'}$	$\frac{\partial M}{\partial \alpha'} \frac{1}{q_0 S \bar{c}}$	$C_{m_{\alpha}} \cos \alpha_0 + \left[ C_{m_u} + \frac{2\tau}{m} T_V \frac{z_T}{\bar{c}} - 2 T_{c_0} \frac{z_T}{\bar{c}} \right] \sin \alpha_0$
	$n_{\beta'}$	$\frac{\partial N}{\partial \beta'} \frac{1}{q_0 S b}$	$C_{n_{\beta}} \cos \alpha_0 + C_{l_{\beta}} \sin \alpha_0$
<b>Moment Rotary</b>	$l_p$	$\frac{\partial L}{\partial p} \frac{1}{q_0 S b}$	$\left[ C_{l_p} \cos^2 \alpha_0 + C_{n_r} \sin^2 \alpha_0 - (C_{l_r} + C_{n_p}) \cos \alpha_0 \sin \alpha_0 \right] \frac{b}{2V_0}$
	$l_r$	$\frac{\partial L}{\partial r} \frac{1}{q_0 S b}$	$\left[ C_{l_r} \cos^2 \alpha_0 - C_{n_p} \sin^2 \alpha_0 + (C_{l_p} - C_{n_r}) \cos \alpha_0 \sin \alpha_0 \right] \frac{b}{2V_0}$
	$m_q$	$\frac{\partial M}{\partial q} \frac{1}{q_0 S \bar{c}}$	$\left[ C_{m_q} \right] \frac{\bar{c}}{2V_0}$
	$n_p$	$\frac{\partial N}{\partial p} \frac{1}{q_0 S b}$	$\left[ C_{n_p} \cos^2 \alpha_0 - C_{l_r} \sin^2 \alpha_0 + (C_{l_p} - C_{n_r}) \cos \alpha_0 \sin \alpha_0 \right] \frac{b}{2V_0}$
	$n_r$	$\frac{\partial N}{\partial r} \frac{1}{q_0 S b}$	$\left[ C_{n_r} \cos^2 \alpha_0 + C_{l_p} \sin^2 \alpha_0 + (C_{l_r} + C_{n_p}) \cos \alpha_0 \sin \alpha_0 \right] \frac{b}{2V_0}$
<b>Moment Control</b>	$l_{\delta_a}$	$\frac{\partial L}{\partial \delta_a} \frac{1}{q_0 S b}$	$C_{l_{\delta_a}} \cos \alpha_0 - C_{n_{\delta_a}} \sin \alpha_0$
	$l_{\delta_r}$	$\frac{\partial L}{\partial \delta_r} \frac{1}{q_0 S b}$	$C_{l_{\delta_r}} \cos \alpha_0 - C_{n_{\delta_r}} \sin \alpha_0$
	$m_{\delta_e}$	$\frac{\partial M}{\partial \delta_e} \frac{1}{q_0 S \bar{c}}$	$C_{m_{\delta_e}}$
	$n_{\delta_a}$	$\frac{\partial N}{\partial \delta_a} \frac{1}{q_0 S b}$	$C_{n_{\delta_a}} \cos \alpha_0 + C_{l_{\delta_a}} \sin \alpha_0$
	$n_{\delta_r}$	$\frac{\partial N}{\partial \delta_r} \frac{1}{q_0 S b}$	$C_{n_{\delta_r}} \cos \alpha_0 + C_{l_{\delta_r}} \sin \alpha_0$

TABLE 19 *Continued*  
 NONDIMENSIONAL STABILITY DERIVATIVES  
 (BODY AXES)

	Symbol	Derivative	Expanded Form in Terms of Stability Axes Derivatives
Moment Acceleration	$m_z$	$\frac{\partial M}{\partial \dot{\alpha}} \frac{1}{q_0 S \bar{c}}$	$(C_{m\dot{\alpha}}) \frac{\bar{c}}{2V_0}$
Notes:			
1. The symbol $q_0$ is the reference dynamic pressure. 2. The symbol $q$ (without subscript) denotes pitching velocity about the Y-axis. 3. The stability axes derivatives are defined in table 20 4. The subscript zero denotes a steady-state reference flight condition. 5. Symbols and notation are given in table 18			

TABLE 20  
 NONDIMENSIONAL STABILITY DERIVATIVES  
 STABILITY AXES

Direct thrust effects not included

I. LONGITUDINAL DERIVATIVES			
Symbol	Derivative	Typical Variation with Mach No. (ref. 16)	Remarks
$C_{x_u}$	$\frac{\partial C_x}{\partial \frac{u}{V_0}}$		$C_{x_u} = - \frac{\partial C_D}{\partial M} M_0 - 2(C_D)_0$ speed damping derivative
$C_{z_u}$	$\frac{\partial C_z}{\partial \frac{u}{V_0}}$		$C_{z_u} = - \frac{\partial C_L}{\partial M} M_0 - 2(C_L)_0$
$C_{m_u}$	$\frac{\partial C_m}{\partial \frac{u}{V_0}}$		$C_{m_u} = \frac{\partial C_m}{\partial M} M_0$ subject to aeroelastic effects
$C_{x_\alpha}$	$\frac{\partial C_x}{\partial \alpha}$		$C_{x_\alpha} = (C_L)_0 - \frac{\partial C_D}{\partial \alpha}$

TABLE 20 Continued

Symbol	Derivative	Typical Variation with Mach No.	Remarks
$C_{z\alpha}$	$\frac{\partial C_z}{\partial \alpha}$		$C_{z\alpha} = - \left[ \frac{\partial C_{L_i}}{\partial \alpha} + (C_D)_\alpha \right]$ <p>approximately the negative of the lift-curve slope</p>
$C_{m\alpha}$	$\frac{\partial C_m}{\partial \alpha}$		<p>static stability derivative that fixes the stick-fixed neutral point; this derivative is a basic static-stability parameter</p>
$C_{m\dot{\alpha}}$	$\frac{\partial C_m}{\partial \left( \frac{\partial \bar{w}}{2V_\infty} \right)}$		<p><math>C_{m\dot{\alpha}}</math> is important in damping of short-period mode; this parameter is subject to high-speed aeroelastic effects</p>
$C_{xq}$	$\frac{\partial C_x}{\partial \left( \frac{q \bar{c}}{2V_\infty} \right)}$		<p>usually not significant</p>
$C_{zq}$	$\frac{\partial C_z}{\partial \left( \frac{q \bar{c}}{2V_\infty} \right)}$		<p>usually neglected; however, aeroelastic effects may become significant at high speeds</p>
$C_{mq}$	$\frac{\partial C_m}{\partial \left( \frac{q \bar{c}}{2V_\infty} \right)}$		<p>pitch-damping derivative; this parameter is significant in the short-period mode</p>
$C_{x\delta_e}$	$\frac{\partial C_x}{\partial \delta_e}$		<p>usually negligible</p>

TABLE 20 *Continued*

Symbol	Derivative	Typical Variation with Mach No.	Remarks
$C_{z\delta}$	$\frac{\partial C_z}{\partial \delta}$		usually small, except for tailless aircraft
$C_{m\delta}$	$\frac{\partial C_m}{\partial \delta}$		control-effectiveness derivative
<b>II. LATERAL DERIVATIVES</b>			
$C_{l_p}$	$\frac{\partial C_l}{\partial \left(\frac{\rho b}{2V_o}\right)}$		damping in roll — $C_{l_p}$ is an important parameter in lateral dynamics
$C_{n_p}$	$\frac{\partial C_n}{\partial \left(\frac{\rho b}{2V_o}\right)}$		important parameter in lateral dynamics; positive values increase damping of the Dutch-roll mode
$C_{x_p}$	$\frac{\partial C_x}{\partial \left(\frac{\rho b}{2V_o}\right)}$		usually negligible
$C_{l_r}$	$\frac{\partial C_l}{\partial \left(\frac{r b}{2V_o}\right)}$		secondary parameter in effect on lateral dynamic motion; influences spiral mode significantly
$C_{n_r}$	$\frac{\partial C_n}{\partial \left(\frac{r b}{2V_o}\right)}$		damping in yaw — $C_{n_r}$ is significant in Dutch-roll and spiral modes

TABLE 20 Continued

Symbol	Derivative	Typical Variation with Mach No.	Remarks
$C_{Yr}$	$\frac{\partial C_Y}{\partial \left( \frac{r b}{2V_o} \right)}$		usually negligible
$C_{l\beta}$	$\frac{\partial C_l}{\partial \beta}$		dihedral effect — $C_{l\beta}$ is important in lateral-dynamic-stability analysis
$C_{n\beta}$	$\frac{\partial C_n}{\partial \beta}$		weathercock static stability parameter; important effects upon lateral dynamics
$C_{Y\beta}$	$\frac{\partial C_Y}{\partial \beta}$		side-force damping derivative — $C_{Y\beta}$ contributes to damping of Dutch roll
$C_{l\dot{\beta}}$	$\frac{\partial C_l}{\partial \left( \frac{\dot{\beta} b}{2V_o} \right)}$		special derivative that is significant at high angles of attack on highly swept and delta-type wings (reference 18)
$C_{n\dot{\beta}}$	$\frac{\partial C_n}{\partial \left( \frac{\dot{\beta} b}{2V_o} \right)}$		see note above for $C_{l\dot{\beta}}$
$C_{l\delta_a}$	$\frac{\partial C_l}{\partial \delta_a}$		aileron effectiveness — important factor in establishing maximum rate of roll

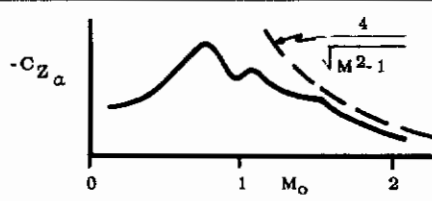
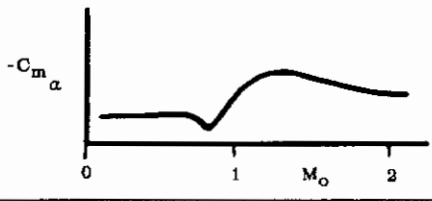
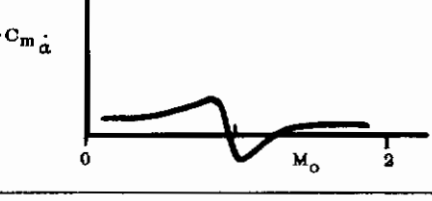
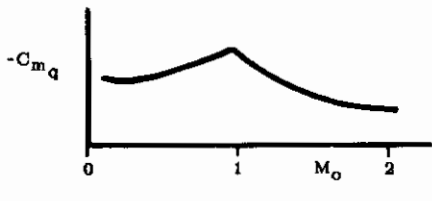
TABLE 20 *Continued*

Symbol	Derivative	Typical Variation with Mach No.	Remarks
$C_{n\delta_a}$	$\frac{\partial C_n}{\partial \delta_a}$		adverse-yaw derivative — an important item in lateral-directional control
$C_{\tau\delta_a}$	$\frac{\partial C_{\tau}}{\partial \delta_a}$		almost always negligible
$C_{l\delta_r}$	$\frac{\partial C_l}{\partial \delta_r}$		usually has a small but significant effect upon control and dynamic-stability analyses
$C_{n\delta_r}$	$\frac{\partial C_n}{\partial \delta_r}$		rudder effectiveness — important to lateral-directional control
$C_{\tau\delta_r}$	$\frac{\partial C_{\tau}}{\partial \delta_r}$		usually negligible in dynamic analyses

**Notes:**

1. The subscript  $o$  denotes a steady-state reference flight condition.
2. The typical variation with Mach number is adapted from reference 16.
3. Methods of evaluating stability derivatives are given in reference 13.
4. Symbols and notation are given in table 18.
5. See reference 18 for additional discussion of typical variations of stability derivatives with Mach numbers.

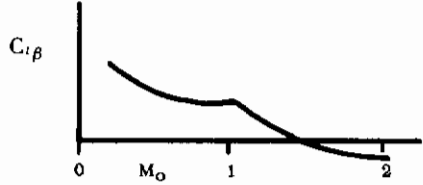
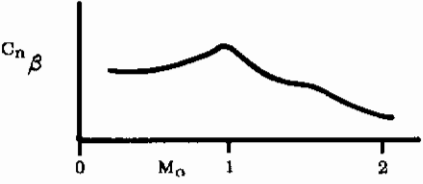
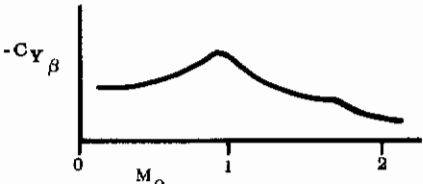
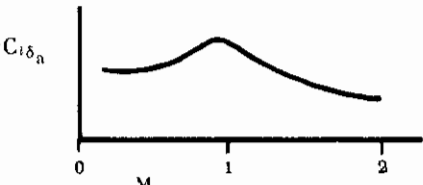
## SECTION 5. SIMPLIFICATION OF THE EQUATIONS OF MOTION

The general equations of motion may usually be simplified for many cases of practical interest. Certain terms become negligibly small or reduce to zero as a result of practical considerations and selection of appropriate reference axes. The methods used to simplify these equations are outlined in the paragraphs that follow.

Equations describing the motion of a rigid body are given in Section 2. In the following pages the real force and moment expressions from Section 4 are used to form equations of motion for an aircraft operating in the atmosphere. Vehicle symmetry and the assumption of small disturbances from reference flight conditions are then used to reduce the equations to simpler forms. The restricted equations of motion are given in nondimensional form also.

Steady equilibrium flight and linearization based upon steady and maneuvering initial flight conditions are discussed as special cases.

### GENERAL SIMPLIFICATION OF RIGID-BODY EQUATIONS

Complete equations of motion for a body moving in the atmosphere are quite complex. Consequently, it is of practical interest to simplify them in order to facilitate analysis of the motion of a body. Vehicle symmetry and restriction of the motion to small disturbances from a reference flight condition are used to reduce certain terms to zero and to linearize the equations.

Initial flight conditions are referred to frequently in subsequent paragraphs. Terms pertaining to these conditions are defined below, as given in reference 19.

**STEADY FLIGHT**—Motion with zero rates of change of the linear and angular velocity components, i.e.,

$$\dot{U} = \dot{V} = \dot{W} = \dot{P} = \dot{Q} = \dot{R} = 0.$$

Steady sideslips, level turns, and helical turns are possible steady flight conditions. Steady pitching flight is a "quasi-steady" condition because  $\dot{U}$  and  $\dot{W}$  cannot both be zero for an appreciable time if  $Q$  is not equal to zero.

**STRAIGHT FLIGHT**—Motion with zero angular velocity components,  $P, Q,$  and  $R = 0$ .

Steady sideslips and dives or climbs without longitudinal acceleration are straight-flight conditions.

**SYMMETRIC FLIGHT**—Motion in which the vehicle plane of symmetry remains fixed in space throughout the maneuver.

The asymmetric variables  $P, R, V, \Phi,$  and  $\Psi$  are all zero in symmetric flight. Some symmetric flight conditions are wings-level dives, climbs, and pullups with no sideslip.

**ASYMMETRIC FLIGHT**—Motion in which any or all of the above asymmetric variables may have non-zero values. Sideslips, rolls, and turns are typical asymmetric flight conditions.

The full set of equations for the motion of a rigid body is given below. These equations are "Eulerian" in that they are referred to axes fixed on the body. Because the coordinate axes rotate with the body, the gravity-vector components depend upon the orientation of the body with respect to a fixed inertial reference (Earth Axes). Relations are thus included to express the kinematic angular-velocity component relations in terms of orientation-angle rates of change.



The equations of motion with reference to general\* body axes ((8) and (9)) are combined with the real force and moment components (equations (32) and (33)). The gravity-force components along body axes are then obtained from the set of equations (34). Angular velocity relations are found in table 16. Collecting and combining these relations give the following sets of dynamic and kinematic equations for the motion of an arbitrary rigid body.

$$\left. \begin{aligned} X + X_T - mg \sin \Theta &= m (\dot{U} - RV + QW) \\ Y + Y_T + mg \cos \Theta \sin \Phi &= m (\dot{V} - PW) + RU \\ Z + Z_T + mg \cos \Theta \cos \Phi &= m (\dot{W} - QU + PV) \end{aligned} \right\} \quad (38)$$

$$\left. \begin{aligned} L + L_T &= \dot{P}I_x - \dot{Q}I_{xy} - \dot{R}I_{zx} - QR(I_y - I_z) - PQI_{zx} \\ &\quad - (Q^2 - R^2)I_{yz} + RPI_{yx} \\ M + M_T &= +\dot{Q}I_y - \dot{R}I_{yz} - \dot{P}I_{xy} - RP(I_z - I_x) - QRI_{xy} \\ &\quad - (R^2 - P^2)I_{zx} + PQI_{zy} \\ N + N_T &= +\dot{R}I_z - \dot{P}I_{zx} - \dot{Q}I_{yz} - PQ(I_x - I_y) - RPI_{yz} \\ &\quad - (P^2 - Q^2)I_{xy} + QRI_{xz} \end{aligned} \right\} \quad (39)$$

$$\left. \begin{aligned} \dot{\Phi} &= P + Q \sin \Phi \tan \Theta + R \cos \Phi \tan \Theta \\ \dot{\Theta} &= Q \cos \Phi - R \sin \Phi \\ \dot{\Psi} &= Q \sin \Phi \sec \Theta + R \cos \Phi \sec \Theta \end{aligned} \right\} \quad (40)$$

The moment equations (39) become significantly simpler when consideration is limited to bodies having symmetry about the XZ-plane. As a consequence of this symmetry, the product-of-inertia terms  $I_{xy}$  and  $I_{yz}$  are zero. The thrust components  $Y_T$ ,  $L_T$ , and  $N_T$  are zero except for special asymmetric-thrust conditions. The dynamic equations for a symmetric body are then the following (references 3 and 4):

$$\left. \begin{aligned} X + X_T - mg \sin \Theta &= m (\dot{U} - RV + QW) \\ Y + mg \cos \Theta \sin \Phi &= m (\dot{V} - PW + RU) \\ Z + Z_T + mg \cos \Theta \cos \Phi &= m (\dot{W} - QU + PV) \end{aligned} \right\} \quad (41)$$

$$\left. \begin{aligned} L &= \dot{P}I_x - (\dot{R} + PQ)I_{xz} - QR(I_y - I_z) \\ M + M_T &= \dot{Q}I_y - (R^2 - P^2)I_{xz} - RP(I_z - I_x) \\ N &= \dot{R}I_z - (\dot{P} - QR)I_{xz} - PQ(I_x - I_y) \end{aligned} \right\} \quad (42)$$

(The angular-velocity relations are unchanged from (40)).

Equations of motion in the form above may be modified to use direction cosines of the gravity vector instead of the orientation angles. The functions of the angles  $\Phi$ ,  $\Theta$ , and  $\Psi$  are replaced by the direction cosines  $l_3$ ,  $m_3$ ,  $n_3$  of the gravity vector from the vehicle body axes. Relations between the direction cosines and the orientation angles are listed below (see page 24).

\*The present discussion is given in terms of general body axes. However, general body axes may be interpreted as any of the axis systems fixed to the vehicle, i.e., body axes, stability axes, or principal axes.

# Contrails

$$\left. \begin{aligned} \ell_3 &= \cos (mg, X) = -\sin \Theta \\ m_3 &= \cos (mg, Y) = \sin \Phi \cos \Theta \\ n_3 &= \cos (mg, Z) = \cos \Phi \cos \Theta \end{aligned} \right\} \quad (43)$$

Substitution of the direction cosines into equations (40) and (41) results in an alternate set of equations of motion for a symmetric body. These equations, which can be found in reference 3, are especially convenient for use with an analog computer. Equations of motion using the direction cosine form are as follows:

$$\left. \begin{aligned} X + X_T + mg \ell_3 &= m (\dot{U} - RV + QW) \\ Y + mg m_3 &= m (\dot{V} - PW + RU) \\ Z + Z_T + mg n_3 &= m (\dot{W} - QU + PV) \end{aligned} \right\} \quad (44)$$

$$\left. \begin{aligned} L &= \dot{P}I_X - (\dot{R} + PQ) I_{XZ} - QR (I_Y - I_Z) \\ M + M_T &= \dot{Q}I_Y - (R^2 - P^2) I_{XZ} - RP (I_Z - I_X) \\ N &= \dot{R}I_Z - (\dot{P} - QR) I_{XZ} - PQ (I_X - I_Y) \end{aligned} \right\} \quad (45)$$

$$\left. \begin{aligned} \dot{\ell}_3 &= m_3 R - n_3 Q \\ \dot{m}_3 &= n_3 P - \ell_3 R \\ \dot{n}_3 &= \ell_3 Q - m_3 P \end{aligned} \right\} \quad (46)$$

Nondimensional forms of the foregoing equations of motion may be obtained by simply dividing through by an appropriate divisor. For the force equations (41) and (44) the divisor is the reference dynamic pressure times the reference area  $\frac{\rho V_o^2}{2} S$ . The moment equations (42) and (45) are divided by  $\frac{\rho V_o^2}{2} S b$  or  $\frac{\rho V_o^2}{2} S \bar{c}$ . The latter value

is used only with the equation for pitching motion. Further use of non-dimensional equations occurs in subsequent Sections, after small-disturbance approximations are introduced.

Many problems of aircraft motion involve only small disturbances from a steady reference flight condition. Thus the approximations compatible with restriction of the motion to small disturbances allow further simplification of the symmetric-body equations (40), (41), and (42).

General notation for small-disturbance analysis is as follows. Perturbations of velocity and orientation variables are designated by the lower case symbols for these quantities, i.e.,  $u, v, w, p, q, r, \phi, \theta,$  and  $\psi$ . Upper case symbols are used with a subscript zero to denote the reference values of these variables. Thus  $U_o, W_o, Q_o, \Theta_o,$  etc. are reference or initial values for velocity components and orientation angles. Incremental changes in aerodynamic force and moment components are denoted by the pertinent symbol with a prefix  $\Delta$ , e.g.,  $\Delta X, \Delta Z, \Delta M,$  etc.

Expansion of the aerodynamic force and moment components for the small-disturbance approximation is discussed in Section 4 and summarized in table 17.

In addition to the perturbation quantities, the approximations noted below are used in the trigonometric relations used with the condition of small disturbances.

$$\left. \begin{aligned} \sin (\Theta_o + \theta) &= \sin \Theta_o \cos \theta + \cos \Theta_o \sin \theta \\ &\approx \sin \Theta_o + \theta \cos \Theta_o \\ \cos (\Theta_o + \theta) &= \cos \Theta_o \cos \theta - \sin \Theta_o \sin \theta \\ &\approx \cos \Theta_o - \theta \sin \Theta_o \end{aligned} \right\} \quad (47)$$

Note: These relations are typical and are applicable to small-disturbance approximations of any regular variable.

If small-disturbance notation and the above approximation for trigonometric functions in equations (40) and (42) are used, the dynamic equations for small-disturbance motion expand to the set of equations below. Products of perturbation quantities are neglected.

$$\left. \begin{aligned} X_o + \Delta X + X_T - mg (\sin \Theta_o + \theta \cos \Theta_o) &= m (\dot{U}_o + \dot{u} - R_o V_o - R_o v - V_o r \\ &\quad + Q_o W_o + Q_o w + W_o q) \\ Y_o + \Delta Y + mg (\cos \Theta_o - \theta \sin \Theta_o) (\sin \Phi_o + \phi \cos \Phi_o) &= m (\dot{V}_o + \dot{v} + R_o U_o \\ &\quad + R_o u + U_o r - P_o W_o - P_o w - W_o p) \\ Z_o + \Delta Z + Z_T + mg (\cos \Theta_o - \theta \sin \Theta_o) (\cos \Phi_o - \phi \sin \Phi_o) &= m (\dot{W}_o + \dot{w} \\ &\quad - Q_o U_o - Q_o u - U_o q + P_o V_o + P_o v + V_o p) \end{aligned} \right\} \quad (48)$$

$$\left. \begin{aligned} L_o + \Delta L &= (\dot{P}_o + \dot{p}) I_X - (\dot{R}_o + \dot{r} + P_o Q_o + P_o q + Q_o p) I_{XZ} \\ &\quad - (Q_o R_o + Q_o r + R_o q) (I_Y - I_Z) \\ M_o + \Delta M + \Delta M_T &= (\dot{Q}_o + \dot{q}) I_Y - (R_o^2 + 2 R_o r - P_o^2 - 2 P_o p) I_{XZ} \\ &\quad - (P_o R_o + P_o r + R_o p) (I_Z - I_X) \\ N_o + \Delta N &= (\dot{R}_o + \dot{r}) I_Z - (\dot{P}_o + \dot{p} - Q_o R_o - Q_o r - R_o q) I_{XZ} \\ &\quad - (P_o Q_o + P_o q + Q_o p) (I_X - I_Y) \end{aligned} \right\} \quad (49)$$

Many of the terms in the above equations are zero for initial conditions of steady, straight, and/or symmetric flight. Linearization of these equations for straight, symmetric flight and maneuvering flight is presented in the following paragraphs.

## SIMPLIFICATION OF EQUATIONS OF MOTION FOR STEADY-FLIGHT CONDITIONS

Steady-flight conditions provide the reference values for many analyses of vehicle motion. The terms used to describe various flight conditions are defined on page 64. The equations of motion are reduced for several steady-flight conditions in the following paragraphs. These relations for steady flight are used subsequently to eliminate initial forces and moments from the equations of motion.

### STEADY, STRAIGHT FLIGHT

This is the simplest case of steady flight. All time derivatives are zero and there is no angular velocity of the body about its center of gravity. Thus, setting all of the time derivatives and the angular-velocity components P, Q, and R equal to zero in equations (41) and (42) results in the following equations for steady, straight flight:

$$\left. \begin{aligned} X + X_T - mg \sin \Theta &= 0 \\ Y + mg \cos \Theta \sin \Phi &= 0 \\ Z + Z_T + mg \cos \Theta \cos \Phi &= 0 \end{aligned} \right\} \quad (50)$$

$$\left. \begin{aligned} L &= 0 \\ M + M_T &= 0 \\ N &= 0 \end{aligned} \right\} \quad (51)$$

Note that these equations are applicable to the steady sideslip. The velocity components V and W and the bank angle are not necessarily zero. When the motion is restricted to symmetric flight, the bank angle is zero. The force equations for steady, straight, symmetric flight are then

$$\left. \begin{aligned} X + X_T - mg \sin \Theta &= 0 \\ Y &= 0 \\ Z + Z_T + mg \cos \Theta &= 0 \end{aligned} \right\} \quad (52)$$

The moments are again all zero (51).

## STEADY TURNS

In the case of steady turning flight the dotted quantities in equations (41) and (42) are zero, as in the preceding case.

Also the orientation angle rates of change  $\dot{\Theta}$  and  $\dot{\Phi}$  are zero and the rate of turn  $\dot{\Psi}$  is constant. With these conditions applied to the dynamic and kinematic equations for rigid-body motions, the relations for steady turning flight may be developed. However, in many cases it is convenient and practical to consider only small elevation angles or shallow climbing and diving turns.

Applying the above conditions to the angular-velocity relations in table 12 results in the following angular-velocity components for a steady turning maneuver. The approximation for small elevation angle ( $\theta$ ) is indicated.

$$\left. \begin{aligned} P &= -\dot{\Psi} \sin \Theta \approx -\dot{\Psi} \theta \\ Q &= \dot{\Psi} \sin \Phi \cos \Theta \approx \dot{\Psi} \sin \Phi \\ R &= \dot{\Psi} \cos \Phi \cos \Theta \approx \dot{\Psi} \cos \Phi \end{aligned} \right\} \quad (53)$$

For most cases of interest  $\dot{\Psi}$  may be considered as a small quantity, so that the products of the angular velocity components P, Q, and R may be neglected. In addition, for coordinated shallow turns, the side force Y is zero and the velocity components V and W are small. The equations for a steady, coordinated, shallow turn become (see reference 4)

$$\left. \begin{aligned} X + X_T - mg \sin \Theta &= 0 \\ mg \sin \Theta &= m \dot{\Psi} U \cos \Phi \\ Z + Z_T + mg \cos \Theta &= -m \dot{\Psi} U \sin \Phi \end{aligned} \right\} \quad (54)$$

$$\left. \begin{aligned} L &= 0 \\ M + M_T &= 0 \\ N &= 0 \end{aligned} \right\} \quad (55)$$

Solution of the second relation of (54) for the rate of turn  $\dot{\Psi}$  results in the following equation:

$$\dot{\Psi} = \frac{g}{U} \tan \Phi \quad (56)$$

## STEADY PITCHING FLIGHT

Symmetric flight of an aircraft along a curved flight path with a constant pitching velocity Q results in a quasi-steady flight condition. The linear velocity components U and W must necessarily vary with time in this case. Thus with the asymmetric velocity components V, P, and R and the bank and yaw angles  $\Phi$  and  $\Psi$  all equal to zero, the equations of motion for a symmetric body (41) and (42) reduce to the following:

# Contrails

$$\left. \begin{aligned} X + X_T - mg \sin \theta &= m (\dot{U} + QW) \\ Y &= 0 \\ Z + Z_T + mg \cos \theta &= m (\dot{W} - QU) \\ L = M + M_T = N &= 0 \end{aligned} \right\} \quad (57)$$

The above relations may be used to evaluate initial conditions for a small-disturbance analysis. The values of  $U_0$  and  $W_0$  may be taken as instantaneous values and the variation with time as disturbance quantities  $u$  and  $w$ , respectively. For reasonable values of pitching velocity the linear accelerations  $\dot{u}$  and  $\dot{w}$  may be neglected, so that the  $X$  and  $Z$  relations above become initial conditions

$$\left. \begin{aligned} (X + X_T)_0 - mg \sin \theta_0 &= m Q_0 W_0 \\ (Z + Z_T)_0 + mg \cos \theta_0 &= -m Q_0 U_0 \end{aligned} \right\} \quad (58)$$

Solution of the second equation above provides a relation between the initial pitching velocity  $Q_0$  and the initial load factor  $n_{z_0}$  along the reference  $Z$ -axis:

$$Q_0 = \frac{g}{U_0} \left( \frac{-(Z + Z_T)_0}{mg} - \cos \theta_0 \right) = \frac{g}{U_0} \left( n_{z_0}^* - \cos \theta_0 \right) \quad (59)$$

## STEADY ROLLING OR SPINNING FLIGHT

In the preceding examples the steady-flight equations readily reduce to simple forms of the equations of motion. However, the equations for steady rolls or spins cannot be simplified without considerable oversimplification of the physical relation describing the motion.

The procedure outlined in references 20 and 21 utilizes only the moment equations to evaluate the perturbed motion from steady roll and spin, respectively. In such cases the steady condition then becomes that of moment equilibrium ( $L = (M + M_T) = N = 0$ ).

## LINEARIZATION FOR STEADY, STRAIGHT, SYMMETRIC INITIAL FLIGHT

Simplification of the equations of motion for small disturbances from a reference steady-flight condition results in the sets of equations (48) and (49). These equations, when combined with the expansion of aerodynamic force and moment components from table 17, form the linearized dynamic equations of rigid-body motion.

In the present case many terms of the equations of motion are zero, and the steady, straight, symmetric flight equations (52) are used to simplify the equations further.

For the steady, straight, symmetric initial flight condition the quantities  $V_0$ ,  $P_0$ ,  $Q_0$ ,  $R_0$ ,  $\Phi_0$ ,  $\Psi_0$ ,  $\dot{U}_0$ ,  $\dot{V}_0$ , and  $\dot{W}_0$  are all zero\*\*. Also, from the steady-flight equations (54), the initial moments ( $L_0$ ,  $M_0 + M_{T_0}$ ,  $N_0$ ) and side force ( $Y_0$ ) are zero. The initial equilibrium in the  $X$  and  $Z$  directions is expressed by the relations

$$\begin{aligned} X_0 + X_{T_0} - mg \sin \theta_0 &= 0 \\ \text{and} \\ Z_0 + Z_{T_0} + mg \cos \theta_0 &= 0 \end{aligned}$$

$$* n_{z_0} = \frac{-(Z + Z_T)_0}{mg}$$

\*\* The subscript zero denotes initial condition.

# Contrails

The initial velocity components  $U_0$  and  $W_0$  are related to the initial velocity  $V_0$  and angle of attack  $\alpha_0$  by the equations below

$$\begin{aligned} U_0 &= V_0 \cos \alpha_0 \\ W_0 &= V_0 \sin \alpha_0 \end{aligned}$$

Application of the foregoing conditions and relations to the small-disturbance equations, (48) and (49), reduces them to the equations below. These are the rigid-body dynamic equations of motion for small disturbances from steady, straight, symmetric flight. Body axes are used with this form of the equations.

$$\left. \begin{aligned} \Delta X - mg \theta \cos \Theta_0 &= m (\dot{u} + q V_0 \sin \alpha_0) \\ \Delta Y + mg \psi \sin \Theta_0 + mg \phi \cos \Theta_0 &= m (\dot{v} + r V_0 \cos \alpha_0 - p V_0 \sin \alpha_0) \\ \Delta Z - mg \theta \sin \Theta_0 &= m (\dot{w} - q V_0 \cos \alpha_0) \end{aligned} \right\} \quad (60)$$

$$\left. \begin{aligned} \Delta L &= \dot{p} I_{XX} - \dot{r} I_{XZ} \\ \Delta M &= \dot{q} I_{YY} \\ \Delta N &= \dot{r} I_{ZZ} - \dot{p} I_{XZ} \end{aligned} \right\} \quad (61)$$

The equations containing  $\Delta X$ ,  $\Delta Z$ , and  $\Delta M$  are commonly referred to as the symmetric or longitudinal equations of motion. The equations for  $\Delta Y$ ,  $\Delta L$ , and  $\Delta M$  are then the asymmetric or lateral equations of motion. In the above equations the thrust contributions to the force and moment component increments should be included in  $\Delta X$ ,  $\Delta Z$ ,  $\Delta M$ , etc.

The expansions of the force and moment component increments for small disturbances are summarized in table 17. The expansion outlined in the table applies to any orthogonal reference axes fixed to the vehicle; however, once axes are established, the components and derivatives may not be interchanged from one axis system to another. The transformation relations necessary to change the derivatives to different reference axes are given in tables 8 and 9.

Within the restriction of small disturbances, the perturbation angular velocities are given by the following relations:

$$p = \dot{\phi}, \quad q = \dot{\theta}, \quad r = \dot{\psi} \quad (62)$$

Linearized equations referred to stability axes are readily obtained from the foregoing set of equations. Stability axes are oriented with the velocity  $V_0$  at the initial flight condition (see page 13). Hence  $U_{s_0} = V_0$  and  $W_{s_0} = 0$ . The initial elevation angle of the stability axes is the initial flight path angle  $\gamma_0$ . These conditions are equivalent to replacing  $\Theta_0$  by  $\gamma_0$  and  $\alpha_0$  by 0 in the linearized body-axis equations. It is important to note, however, that all of the velocity, force, and moment components in the new set of equations are referred to *stability axes*. The linearized equations of motion referred to stability axes are given below. These equations are restricted to small disturbances from steady, straight, symmetric flight.

$$\left. \begin{aligned} \Delta X - mg \theta \cos \gamma_0 &= m \dot{u} \\ \Delta Y + mg \psi \sin \gamma_0 + mg \phi \cos \gamma_0 &= m (\dot{v} + r V_0) \\ \Delta Z - mg \theta \sin \gamma_0 &= m (\dot{w} - q V_0) \end{aligned} \right\} \quad (63)$$

$$\left. \begin{aligned} \Delta L &= \dot{p} I_{X_s} - \dot{r} I_{XZ_s} \\ \Delta M &= \dot{q} I_{Y_s} \\ \Delta N &= \dot{r} I_{Z_s} - \dot{p} I_{XZ_s} \end{aligned} \right\} \quad (64)$$

( $\Delta X, \Delta Y, \dots, \Delta N, \phi, \theta, \psi, u, v, w, p, q,$  and  $r$  are referred to stability axes in these equations.)

Aerodynamic forces and moments are usually reduced to nondimensional coefficient form. Hence it is convenient to express the foregoing equations of motion in nondimensional form. First the force and moment component increments,  $\Delta X, \Delta M,$  etc., are expanded as indicated in table 17. The resulting equations are then reduced to nondimensional form and tabulated in tables 21 and 22. The equations are regrouped into the longitudinal and lateral equations.

The tabular presentation of these equations is taken from reference 3. Coefficients of the small-disturbance variables are arrayed so that the desired equation is obtained by setting the sum of the products of the coefficients and appropriate variables horizontally across each row equal to zero. The appropriate variable is given at the head of each column. For example, the force equation along the body X-axis is the following:

$$\left( \frac{x_u'}{2\tau} - \frac{d}{dt} \right) u' + \frac{x_\alpha'}{\tau} \alpha' + \left( \frac{x_q}{2\tau} - \sin \alpha_0 \right) \frac{d(\theta)}{dt} - \frac{g\theta}{V_0} \cos \Theta_0 + \frac{x_\delta}{\tau} \delta = 0$$

Note that the operator  $\frac{d}{dt}$  is included in the coefficient of the variable. Notation used in the nondimensional equations is summarized in table 18.

TABLE 21  
NONDIMENSIONAL EQUATIONS OF MOTION FOR SMALL DISTURBANCES  
FROM STEADY, STRAIGHT, SYMMETRIC FLIGHT  
BODY AXES

Longitudinal Equations	Disturbance Variable Coefficients			
	$u'$	$\alpha'$	$\theta$	$\delta$
Force Equation Along X-axis	$\frac{x_u'}{2\tau} - \frac{d}{dt}$	$\frac{x_\alpha'}{2\tau}$	$\left( \frac{x_q}{2\tau} - \sin \alpha_0 \right) \frac{d}{dt}$ $- \frac{g}{V_0} \cos \Theta_0$	$\frac{x_\delta}{2\tau}$
Force Equation Along Z-axis	$\frac{z_u'}{2\tau}$	$\frac{z_\alpha'}{2\tau} - \frac{d}{dt}$	$\left( \frac{z_q}{2\tau} + \cos \alpha_0 \right) \frac{d}{dt}$ $- \frac{g}{V_0} \sin \Theta_0$	$\frac{z_\delta}{2\tau}$
Moment Equation About Y-axis	$m_u'$	$m_\alpha' + m_\alpha' \frac{d}{dt}$	$m_q \frac{d}{dt} - C_{IY} \frac{d^2}{dt^2}$	$m_\delta$

Lateral Equations	Disturbance Variable Coefficients				
	$\beta'$	$\phi$	$\psi$	$\delta_a$	$\delta_r$
Force Equation Along Y-axis	$\frac{y_\beta'}{2\tau} - \frac{d}{dt}$	$\left( \frac{y_\phi}{2\tau} + \sin \alpha_0 \right) \frac{d}{dt}$ $+ \frac{g}{V_0} \cos \Theta_0$	$\left( \frac{y_\psi}{2\tau} - \cos \alpha_0 \right) \frac{d}{dt}$ $+ \frac{g}{V_0} \sin \Theta_0$	$\frac{y_{\delta_a}}{2\tau}$	$\frac{y_{\delta_r}}{2\tau}$
Moment Equation About X-axis	$l_\beta' + \frac{d}{dt} l_\beta'$	$l_\phi \frac{d}{dt} - C_{IX} \frac{d^2}{dt^2}$	$l_\psi \frac{d}{dt} + C_{IXZ} \frac{d^2}{dt^2}$	$l_{\delta_a}$	$l_{\delta_r}$
Moment Equation About Z-axis	$l_\beta' + \frac{d}{dt} n_\beta'$	$n_\phi \frac{d}{dt} + C_{IXZ} \frac{d^2}{dt^2}$	$n_\psi \frac{d}{dt} - C_{IZ} \frac{d^2}{dt^2}$	$n_{\delta_a}$	$n_{\delta_r}$

Symbols and notation are given in table 18.

TABLE 22

NONDIMENSIONAL EQUATIONS OF MOTION FOR SMALL DISTURBANCES  
FROM STEADY, STRAIGHT, SYMMETRIC FLIGHT

STABILITY AXES

(SIMPLIFIED FORM)

Longitudinal Equations	Disturbance Variable Coefficients			
	$u'$	$\alpha'$	$\theta$	$\delta$
Force Equation Along X-axis	$2 (C_D)_0 + 2\tau \frac{d}{dt}$	$-(C_L)_0 + C_{D\alpha}$	$C_{Dq} \frac{\bar{c}}{2V_0} \frac{d}{dt} + (C_L)_0$	$C_{D\delta}$
Force Equation Along Z-axis	$2 (C_L)_0$	$C_{L\alpha} + (C_D)_0 + 2\tau \frac{d}{dt}$	$(C_{Lq} \frac{\bar{c}}{2V_0} - 2\tau) \frac{d}{dt} + (C_L)_0 \tan \gamma_0$	$C_{L\delta}$
Moment Equation About Y-axis	0	$C_{m\alpha} + C_{m\dot{\alpha}} \frac{\bar{c}}{2V_0} \frac{d}{dt}$	$C_{mq} \frac{\bar{c}}{2V_0} \frac{d}{dt} - C_{IY} \frac{d^2}{dt^2}$ *	$C_{m\delta}$

Lateral Equations	Disturbance Variable Coefficients				
	$\beta'$	$\phi$	$\psi$	$\delta_a$	$\delta_r$
Force Equation Along Y-axis	$C_{Y\beta} - 2\tau \frac{d}{dt}$	$C_{Yp} \frac{b}{2V_0} \frac{d}{dt} + (C_L)_0$	$(C_{Yr} \frac{b}{2V_0} - 2\tau) \frac{d}{dt} + (C_L)_0 \tan \gamma_0$	$C_{Y\delta_a}$	$C_{Y\delta_r}$
Moment Equation About X-axis	$C_{I\beta}$	$C_{Ip} \frac{b}{2V_0} \frac{d}{dt} - C_{IX} \frac{d^2}{dt^2}$ *	$C_{Ir} \frac{b}{2V_0} \frac{d}{dt} + C_{IXZ} \frac{d^2}{dt^2}$ *	$C_{I\delta_a}$	$C_{I\delta_r}$
Moment Equation About Z-axis	$C_{n\beta}$	$C_{np} \frac{b}{2V_0} \frac{d}{dt} + C_{nXZ} \frac{d^2}{dt^2}$ *	$C_{nr} \frac{b}{2V_0} \frac{d}{dt} - C_{Iz} \frac{d^2}{dt^2}$ *	$C_{n\delta_a}$	$C_{n\delta_r}$

Symbols and notation are given in table 18.

\*  $C_{IX}$ ,  $C_{IY}$ ,  $C_{IZ}$ , and  $C_{IXZ}$  must be determined with respect to the stability axes and hence are not the same as in table 21.



## LINEARIZATION FOR STEADY MANEUVERING FLIGHT

There are certain types of problems in analysis of vehicle motion in which the assumption of small disturbances from a steady maneuvering flight condition is the most efficient method of approach. The limitation to a steady, straight, symmetric initial flight condition is unnecessarily restrictive.

General equations for small-disturbance motions from steady flight are derived and summarized concisely in reference 22. These equations are equations of motion for small disturbances from steady turning, pitching, rolling, or longitudinally accelerating flight. Table 23 gives the general dimensional equations for small-disturbance motion. The next table (24) summarizes the conditions to be used in the general equations of table 23 for the several types of steady initial flight conditions.

These equations readily reduce to those used in special cases treated in the literature, e.g., references 20 and 23. Also, the small-disturbance equations of the preceding Section for steady, straight, symmetric flight may be obtained from table 23. Stability axes are the reference axes for this case and the notation is defined in table 18.

TABLE 23  
GENERAL EQUATIONS OF MOTION FOR SMALL DISTURBANCES FROM STEADY FLIGHT  
STABILITY AXES

	Coefficient of Disturbance Variable					
	u	v	w	p	q	r
$\frac{\Delta X}{m} + \left(\frac{dV}{dt}\right)_o = \frac{d(\quad)}{dt}$	-R <sub>o</sub>	Q <sub>o</sub>	0	0	$g \cos \gamma_o \cos \Phi_o \int (\quad) dt$	$-g \cos \gamma_o \sin \Phi_o \int (\quad) dt$
$\frac{\Delta Y}{m} =$	R <sub>o</sub>	$\frac{d(\quad)}{dt}$	-P <sub>o</sub>	$-g \cos \gamma_o \cos \Phi_o \int (\quad) dt$	0	$V_o - \left[ g \sin \gamma_o + \left(\frac{dV}{dt}\right)_o \right] \int (\quad) dt$
$\frac{\Delta Z}{m} =$	-Q <sub>o</sub>	P <sub>o</sub>	$\frac{d(\quad)}{dt}$	$g \cos \gamma_o \sin \Phi_o \int (\quad) dt$	$-V_o + \left[ g \sin \gamma_o + \left(\frac{dV}{dt}\right)_o \right] \int (\quad) dt$	0
$\Delta L =$	0	0	0	$I_{x_s} \frac{d(\quad)}{dt} - Q_o I_{xz_s}$	$R_o (I_{z_s} - I_{r_s}) - P_o I_{xz_s}$	$-I_{xz_s} \frac{d(\quad)}{dt} + Q_o (I_{z_s} - I_{r_s})$
$\Delta M =$	0	0	0	$R_o (I_{x_s} - I_{z_s}) + 2 P_o I_{xz_s}$	$I_{y_s} \frac{d(\quad)}{dt}$	$P_o (I_{x_s} - I_{z_s}) - 2 R_o I_{xz_s}$
$\Delta N =$	0	0	0	$-I_{xz_s} \frac{d(\quad)}{dt} + Q_o (I_{r_s} - I_{x_s})$	$P_o (I_{y_s} - I_{x_s}) + R_o I_{xz_s}$	$I_{z_s} \frac{d(\quad)}{dt} + Q_o I_{xz_s}$

Note:  $\phi = \int p dt$

$\theta = \int q dt$

$\psi = \int r dt$

Symbols and notation defined on table 18

TABLE 24

INITIAL CONDITIONS FOR GENERAL SMALL-DISTURBANCE EQUATIONS OF MOTION

STABILITY AXES

(Conditions for use with table 23 )

Initial Flight Condition	Initial Value of Velocity Components and Orientation Angles	Remarks
Steady Straight Symmetric Flight	$U_o = V_o; V_o = W_o = \left(\frac{dV}{dt}\right)_o = 0$ $P_o = Q_o = R_o = 0$ $\gamma_o = \gamma_o; \Phi_o = 0$	Same as presented on page 70 (see equations (63) and (64)).
Steady Turning Flight	$U_o = V_o; V_o = W_o = \left(\frac{dV}{dt}\right)_o = 0$ $P_o = -\dot{\Psi}_o \sin \gamma_o$ $Q_o = \dot{\Psi}_o \cos \gamma_o \sin \Phi_o$ $R_o = \dot{\Psi}_o \cos \gamma_o \cos \Phi_o$ $\gamma_o = \gamma_o; \Phi_o = \Phi_o;$	Steady-turn conditions also in equations (53) $\dot{\Psi} = \frac{g}{V_o} \tan \Phi_o$
Steady Rolling Flight	$U_o = V_o; V_o = W_o = \left(\frac{dV}{dt}\right)_o = 0$ $P_o = P_o; Q_o = R_o = 0$ $\gamma_o = \gamma_o; \Phi_o = \Phi_o;$	These conditions are used in references 20 and 23
Steady Pitching Flight	$U_o = V_o; V_o = W_o = \left(\frac{dV}{dt}\right)_o = 0$ $P_o = R_o = 0; Q_o = \frac{g}{V_o} (n_o^* - \cos \gamma_o)$ $\gamma_o = \gamma_o; \Phi_o = 0$	n <sub>o</sub> or Q <sub>o</sub> may be used to specify the initial conditions. This is only a quasi-steady flight condition.
Steady Longitudinal Acceleration	$U_o = V_o; V_o = W_o = 0$ $P_o = Q_o = R_o = 0$ $\gamma_o = \gamma_o; \Phi_o = 0$ $\left(\frac{dV}{dt}\right)_o = \text{constant}$	This flight condition is also quasi-steady, since $\dot{U} \neq 0$ .

Note:  $\Phi$  and  $\Psi$  are orientation angles of stability axes. Symbols and notation are defined on table 18.

\* The symbol n in this expression denotes load factor.

In addition to the equations of motion given in table 23 there are other specialized forms of these equations. The study of small disturbances from steady pitching flight may be conveniently made with vehicle body axes for reference. Below are the equations for analysis of small-disturbance motion from "steady" pitching flight\* as given in reference 3. Body axes are used and notation is defined in table 18.

$$\begin{aligned}
 \Delta X - \theta mg \cos \theta_0 &= m (\dot{u} + q V_0 \sin \alpha_0 + w Q_0) \\
 \Delta Y + \psi mg \sin \theta_0 + \phi mg \cos \theta_0 &= m (\dot{v} + r V_0 \cos \alpha_0 - p V_0 \sin \alpha_0) \\
 \Delta Z - \theta mg \sin \theta_0 &= m (\dot{w} - q V_0 \cos \alpha_0 - u Q_0) \\
 \Delta L &= I_x \dot{p} - I_{xz} \dot{r} + Q_0 r (I_z - I_y) - Q_0 p I_{xz} \\
 \Delta M &= I_y \dot{q} \\
 \Delta N &= I_z \dot{r} - I_{xz} \dot{p} + Q_0 p (I_y - I_x) + Q_0 r I_{xz}
 \end{aligned}
 \tag{65}$$

Note: These equations may be developed from (48) and (49).

$$U_0 = V_0 \cos \alpha_0; V_0 = 0; W_0 = V_0 \sin \alpha_0$$

$$\text{also } P_0, R_0, \Phi_0 = 0$$

(66)

The steady pitching velocity is given by

$$Q_0 = \frac{g}{V_0 \cos \alpha_0} (n_{z_0} - \cos \theta_0)$$

In the above relation either the initial pitching velocity  $Q_0$  or the initial load factor  $n_{z_0}$  may be specified.

A specialized case of small disturbance from a steady flight condition occurs in the analysis of the spinning motion of an aircraft. An analysis of the dynamics and stability of flat spins is contained in reference 21. Because of the specialized nature of the analysis and the likelihood of confusion in the symbols and notation, the equations are not repeated here.

## ADDITIONAL SPECIALIZED FORMS OF THE EQUATIONS OF MOTION

Rigid-body equations of motion have been developed and specialized for many specific and special problems. No attempt has been made to collect them all here. However, some generally useful forms of these equations are summarized in this Section.

\* See definition of steady flight on page 64.

## LARGE DISTURBANCES FROM STEADY, STRAIGHT, SYMMETRIC FLIGHT. (References 3 and 19)

In the equations of motion presented below, the approximation of small disturbances has been limited to the linear velocity components U, V, and W. The remaining orientation angles and angular-velocity components are not restricted to small values as in the case of general small-disturbance motion. Many practical problems in aircraft motion may be analyzed under these conditions.

The initial condition used is steady, straight, symmetric flight; hence  $V_0(\beta_0)$ ,  $P_0$ ,  $Q_0$ ,  $R_0$ , and  $\Phi_0$  are zero. The small, nondimensional linear velocity disturbances are denoted by  $u'$ ,  $\beta'$ , and  $\alpha'$ , and the reference axes are the vehicle body axes. These equations are developed from the symmetric rigid-body equations (41) and (42) and put in nondimensional form. Special notation used in these equations is defined in table 18.

$$\begin{aligned}
 & \left( \frac{x_u'}{2r} - \frac{d}{dt} \right) u' + \frac{x_{\alpha'}}{2r} \alpha' + \left( \frac{x_q}{2r} - \sin \alpha_0 \right) Q + \beta' R - \alpha' Q \\
 & \quad + \frac{x_{\delta_e}}{2r} \delta_e - \frac{g}{V_0} \sin \Theta + \frac{g}{V_0} \sin \Theta_0 = 0 \\
 & \left( \frac{y_{\beta}'}{2r} - \frac{d}{dt} \right) \beta' + \left( \frac{y_p}{2r} + \sin \alpha_0 \right) P + \left( \frac{y_r}{2r} - \cos \alpha_0 \right) R - u' R + \alpha' P \\
 & \quad + \frac{y_{\delta_a}}{2r} \delta_a + \frac{y_{\delta_r}}{2r} \delta_r + \frac{g}{V_0} \sin \Phi \cos \Theta = 0 \\
 & \frac{z_u'}{2r} u' + \left( \frac{z_{\alpha'}}{2r} - \frac{d}{dt} \right) \alpha' + \left( \frac{z_q}{2r} + \cos \alpha_0 \right) Q + u' Q - \beta' P \\
 & \quad + \frac{z_{\delta_e}}{2r} \delta_e + \frac{g}{V_0} \cos \Phi \cos \Theta - \frac{g}{V_0} \cos \Theta_0 = 0 \\
 & \frac{l_{\beta}'}{C_{I_X}} \beta' + \left( \frac{l_p}{C_{I_X}} - \frac{d}{dt} \right) P + \frac{H_e \sin i_T}{I_X} Q + \left( \frac{l_r}{C_{I_X}} + \frac{I_{XZ}}{I_X} \frac{d}{dt} \right) R \\
 & \quad + \frac{I_{XZ}}{I_X} PQ + \left( \frac{I_Y - I_Z}{I_X} \right) QR + \frac{l_{\delta_a}}{C_{I_X}} \delta_a + \frac{l_{\delta_r}}{C_{I_X}} \delta_r = 0 \\
 & \frac{m_u'}{C_{I_Y}} u' + \left( \frac{m_{\alpha'}}{C_{I_Y}} + \frac{m_{\alpha'}'}{C_{I_Y}} \frac{d}{dt} \right) \alpha' - \frac{H_e \sin i_T}{I_Y} P + \left( \frac{m_q}{C_{I_Y}} - \frac{d}{dt} \right) Q \\
 & \quad - \frac{H_e \cos i_T}{I_Y} R + \left( \frac{I_Z - I_X}{I_Y} \right) PR - \frac{I_{XZ}}{I_Y} (P^2 - R^2) + \frac{m_{\delta_e}}{C_{I_Y}} \delta_e = 0 \\
 & \frac{n_{\beta}'}{C_{I_Z}} \beta' + \left( \frac{n_p}{C_{I_Z}} + \frac{I_{XZ}}{I_Z} \frac{d}{dt} \right) P + \frac{H_e \cos i_T}{I_Z} Q + \left( \frac{n_r}{C_{I_Z}} - \frac{d}{dt} \right) R + \left( \frac{I_X - I_Y}{I_Z} \right) PQ \\
 & \quad - \frac{I_{XZ}}{I_Z} QR + \frac{n_{\delta_a}}{C_{I_Z}} \delta_a + \frac{n_{\delta_r}}{C_{I_Z}} \delta_r = 0
 \end{aligned} \tag{67}$$

Note: 1. Engine angular momentum,  $H_e$ , is included in this set of equations.

Note: 2. Symbols and notation are defined in table 18.

Note 3. Reference axes are vehicle body axes.

## EQUATIONS OF MOTION ALONG WIND AXES

Generally the dynamic equations of motion along wind axes are too cumbersome for use in vehicle-motion analysis. The variation of inertia parameters with orientation angles precludes any extensive exploitation of the simplified aerodynamic terms along wind axes. The dynamic force equations and kinematic relations are sometimes useful, however, and are therefore given here (equations (68) and (69)). These are taken from reference 3, but they may be developed directly from equations (40) and (41). (Symbols and notation are defined in table 18.)

$$\left. \begin{aligned}
 T - D - mg \sin \gamma &= m \dot{V} \\
 -T\beta + C + mg \sin \Phi \cos \gamma &= m V (\dot{\beta} + R - P\alpha) \\
 &= m V (\Omega'_z) \\
 -T(a + i_T) - L + mg \cos \Phi \cos \gamma &= m V (\dot{\alpha} - Q + P\beta) \\
 &= m V (-\Omega'_y)
 \end{aligned} \right\} \quad (68)$$

$$\left. \begin{aligned}
 \dot{\Phi} &= \Omega'_x + (\Omega'_y \sin \Phi + \Omega'_z \cos \Phi) \tan \gamma = \Omega'_x + \psi \sin \gamma \\
 \dot{\gamma} &= \Omega'_y \cos \Phi - \Omega'_z \sin \Phi \\
 \dot{\psi} &= (\Omega'_y \sin \Phi + \Omega'_z \cos \Phi) \sec \gamma
 \end{aligned} \right\} \quad (69)$$

From the second and third equations above, the following relations for the rates of change of angle of attack and of sideslip angle are obtained.

$$\left. \begin{aligned}
 \dot{\alpha} &= Q - P\beta - \Omega'_y \\
 \dot{\beta} &= P\alpha - R + \Omega'_z
 \end{aligned} \right\} \quad (70)$$

A practical application of the above equations occurs in the simplified analysis of inertial coupling, e.g., that of reference 24. In this case it was desired to develop a simplified analysis that provided a quick and simple method for surveying the dynamics of a rolling aircraft. Problem areas could subsequently be more thoroughly and rigorously investigated. The simplified analysis was then made by using the above force equations along wind axes and the moment equations along principal axes (equation (13)).

## SECTION 6. SOLUTION OF THE EQUATIONS OF MOTION

The equations developed and presented in the preceding Sections describe the motion of a particle mass and that of a rigid body. Solutions of the complete equations are not always possible or may be impractical for the problem under consideration. Several methods of simplifying these equations are given in Section 5.

Methods for solving differential equations found in many standard mathematics texts may be applied to find solutions of the equations of motion. Some general methods for solving the equations of motion are outlined in the paragraphs that follow. Included in this Section is a brief discussion of computer methods and of some approximate solutions. The approximation formulas are useful for preliminary estimates of dynamic stability characteristics.

### ANALYTICAL METHODS

Solution of the simplified equations of motion by analytical methods is possible in many cases. The simplified equations are generally a system of ordinary linear differential equations having constant coefficients.

Use of the direct method of solution is outlined for the linearized small-disturbance equations. The Laplace transform method is also outlined and a matrix method noted.

Analytical methods for solution of nonlinear systems of differential equations are not included. References 25 and 26 present analytical methods for obtaining solutions of the motion in nonlinear dynamic systems.

### DIRECT METHOD OF SOLUTION

The direct method of solution for a system of ordinary linear differential equations, such as the small-disturbance equations of motion, is described and illustrated in Chapters 6 and 7 of reference 4. This procedure is reviewed below with the longitudinal equations of motion as an example.

Equations of motion for small disturbances are separated into a set of longitudinal equations (symmetric) and a set of lateral equations. These equations are given in nondimensional form in tables 21 and 22. The longitudinal equations from table 22 are used below to illustrate the direct method of solution.

If the control remains fixed,  $\delta$  is zero and the longitudinal equations reduce to a system of simultaneous ordinary homogeneous differential equations. These equations then have the dependent variables  $u'$ ,  $\alpha'$ , and  $\theta$  as functions of time, the independent variable.

The solution for the dependent variables is then assumed to be

$$\left. \begin{aligned} u' &= u'_0 e^{\lambda t} \\ \alpha' &= \alpha'_0 e^{\lambda t} \\ \theta &= \theta_0 e^{\lambda t} \end{aligned} \right\} \quad (71)$$

Substituting these relations into the longitudinal equations of table 22 results in the set of equations below.

$$\left. \begin{aligned} [2(C_D)_0 + 2\tau\lambda] u'_0 e^{\lambda t} + [C_{D_\alpha} - (C_L)_0] \alpha'_0 e^{\lambda t} + (C_L)_0 \theta_0 e^{\lambda t} &= 0 \\ 2(C_L)_0 u'_0 e^{\lambda t} + [C_{L_\alpha} + (C_D)_0 + 2\tau\lambda] \alpha'_0 e^{\lambda t} - 2\tau\lambda \theta_0 e^{\lambda t} &= 0 \\ \left[ C_{m_\alpha} + C_{m_{\dot{\alpha}}} \frac{\bar{c}}{2V_0} \lambda \right] \alpha' e^{\lambda t} + \left[ C_{m_q} \frac{\bar{c}}{2V_0} \lambda - C_{I_Y} \lambda^2 \right] \theta_0 e^{\lambda t} &= 0 \end{aligned} \right\}$$

Note:  $C_{D_q}$  and  $C_{L_q}$  are assumed negligible. Steady level symmetric flight is assumed ( $\gamma_0 = 0$ ). Notation is given in table 18.

The factor  $e^{\lambda t}$  is common to all terms in the above equations and may be divided out.\* The result is then a set of linear simultaneous algebraic equations in the variables  $u'_0$ ,  $\alpha'_0$ , and  $\theta_0$  with a parameter  $\lambda$  to be determined. The condition upon  $\lambda$  required for nonzero values of the dependent variables is that the determinant of coefficients of equations (72) be zero.\*\* Thus,

$$\begin{vmatrix} [2(C_D)_0 + 2\tau\lambda] & [C_{D_\alpha} - (C_L)_0] & (C_L)_0 \\ 2(C_L)_0 & [C_{L_\alpha} + (C_D)_0 + 2\tau\lambda] & -2\tau\lambda \\ 0 & \left[ C_{m_\alpha} + C_{m_\alpha} \frac{\bar{c}}{2V_0} \lambda \right] & \left[ C_{m_q} \frac{\bar{c}}{2V_0} \lambda - C_{I_Y} \lambda^2 \right] \end{vmatrix} = 0 \quad (73)$$

Expansion of this determinant results in the characteristic equation for the solution. This is a fourth-degree polynomial in the parameter  $\lambda$ .

$$A\lambda^4 + B\lambda^3 + C\lambda^2 + D\lambda + E = 0 \quad (74)$$

where:

$$A = -4\tau^2 C_{I_Y}$$

$$B = -2\tau C_{I_Y} (3C_{D_0} + C_{L_\alpha}) + 4\tau^2 \left( \frac{\bar{c}}{2V_0} C_{m_q} + \frac{\bar{c}}{2V_0} C_{m_{\dot{\alpha}}} \right)$$

$$C = -2C_{I_Y} (C_{D_0} C_{L_\alpha} - C_{L_0} C_{D_\alpha}) - 2C_{D_0}^2 C_{I_Y} - 2C_{L_0}^2 C_{I_Y} + 4\tau \left[ C_{D_0} \left( \frac{\bar{c}}{2V_0} C_{m_q} + \frac{\bar{c}}{2V_0} C_{m_{\dot{\alpha}}} \right) \right. \\ \left. + 2\tau C_{D_0} \left( \frac{\bar{c}}{2V_0} C_{m_q} \right) + 2\tau C_{L_\alpha} \left( \frac{\bar{c}}{2V_0} C_{m_q} \right) + 4\tau^2 C_{m_\alpha} \right]$$

$$D = 2C_{L_0}^2 \left( \frac{\bar{c}}{2V_0} C_{m_q} + \frac{\bar{c}}{2V_0} C_{m_{\dot{\alpha}}} \right) + 2C_{D_0} C_{L_\alpha} \left( \frac{\bar{c}}{2V_0} C_{m_q} \right) + 2C_{D_0}^2 \left( \frac{\bar{c}}{2V_0} C_{m_q} \right) - 2C_{L_0} C_{D_\alpha} \left( \frac{\bar{c}}{2V_0} C_{m_q} \right) + 4\tau C_{D_0} C_{m_\alpha}$$

$$E = 2C_{L_0}^2 C_{m_\alpha}$$

The roots of this equation are the values of  $\lambda$  corresponding to the modes of motion.

The roots of (74) may be real or complex. The complex roots necessarily occur in conjugate pairs and denote an oscillating mode of motion. Each real root corresponds to a pure convergence or divergence without any oscillation.\*\*\* Convergence or divergence of each mode of motion is established by the sign of the real root or the real part of the complex conjugate roots. Four types of motion are possible, as illustrated in figure 24, for the function  $\theta = \theta_0 e^{\lambda t}$

\*The solution  $e^{\lambda t} = 0$  is trivial.

\*\*Note that the solution for any of the variables in equation (72) would have the determinant in the numerator equal to zero. Thus for a variable to have a nonzero value the denominator determinant must be zero. The resulting indeterminate form may then have nonzero values. Also it should be noted that the general solution of the longitudinal equations involves a forcing function such as a control pulse, so that the right side of equation (72) is not all zero.

\*\*\*Whenever the characteristic equation is of an odd degree, it must have at least one real root.

# Contrails

The behavior of the dependent variables  $u'$ ,  $a'$ , and  $\theta$  may be determined, once the roots of the characteristic equation (values of  $\lambda$ ) are known. The variation of these quantities with time is then given by equations (71) for each mode of motion of the system, with additional constant multiplying factors depending upon the input.

In addition to the time history of each dependent variable, several quantitative parameters that describe the motion may be determined from the roots of the characteristic equation. These items are the period and the time to halve (or double) the initial amplitude. The cycles to halve (or double) the amplitude of oscillatory motion are also of interest. Table 25 lists these items for both real and complex conjugate roots of the characteristic equation.

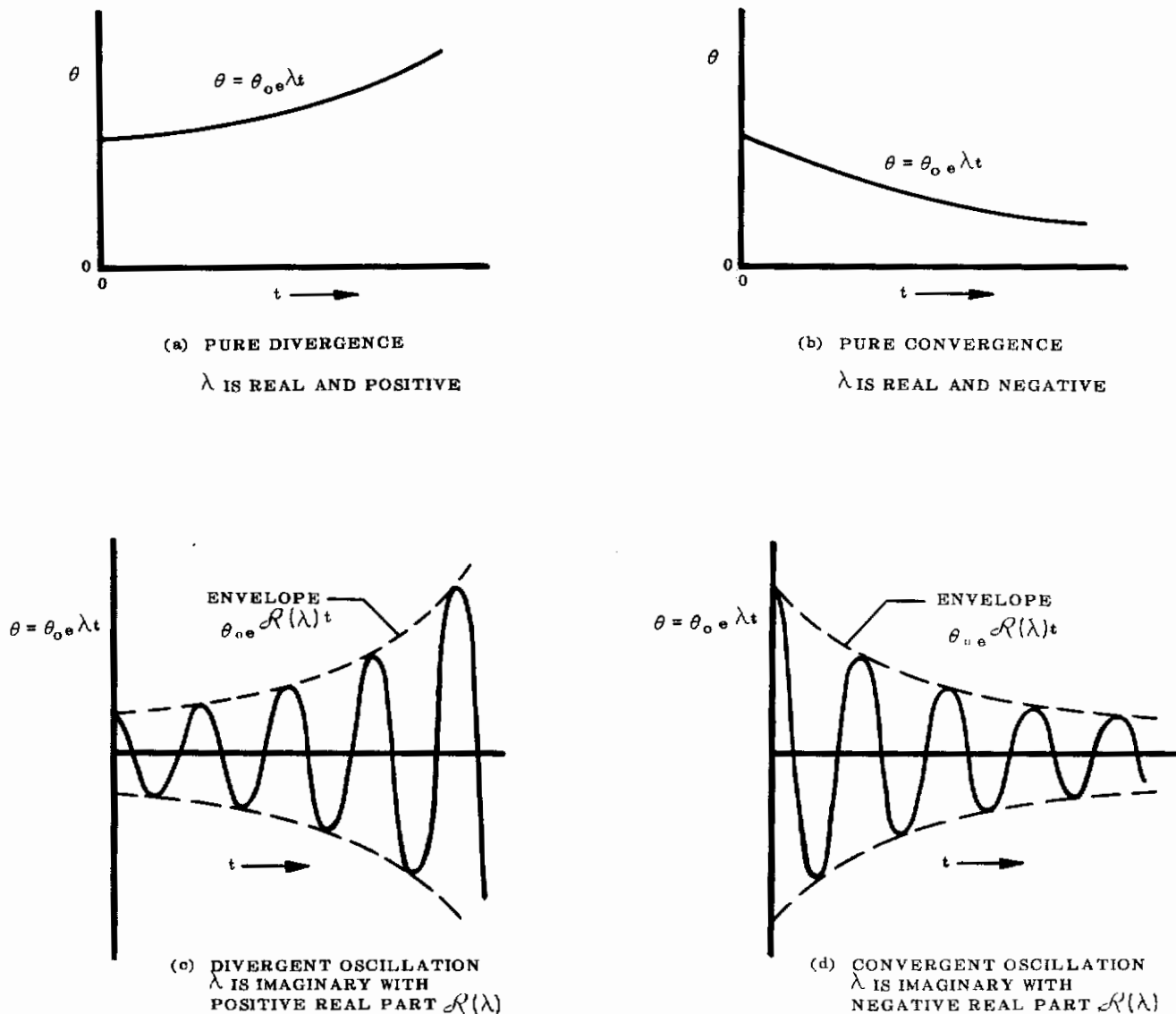

FIGURE 24 TYPES OF MOTION FOR DIFFERENT ROOTS OF THE CHARACTERISTIC EQUATION



**TABLE 25**  
**QUANTITATIVE CHARACTERISTICS OF MODES OF MOTION \***

Characteristic of the Motion	Real $\lambda$	Complex $\lambda$
Time to halve or double amplitude	$= \frac{0.693}{ \lambda }$	$= \frac{0.693}{ \mathcal{R}(\lambda) }$
Period	Not Applicable	$= \frac{2\pi}{ \mathcal{I}(\lambda) }$
Cycles to halve or double amplitude	Not Applicable	$= 0.110 \frac{ \mathcal{I}(\lambda) }{ \mathcal{R}(\lambda) }$

### LAPLACE TRANSFORM METHOD OF SOLUTION

Use of the Laplace transformation in the solution of linear differential equations has several advantages when compared with the direct method of solution. This method of solution of the small-disturbance equations of motion is explained and illustrated in references 4 and 11. There are numerous texts that contain the mathematical development of the Laplace transform, such as references 27 and 28. These references also provide additional examples and tables of Laplace transforms.

The primary advantages of using Laplace transformations to obtain solutions of systems of linear differential equations are:

1. Initial conditions are introduced directly into the solution in order to avoid the evaluation of the constants of integration required by direct methods.

2. In problems involving several dependent variables the solution for one variable may be obtained independently. The literature provides detailed treatment of the Laplace transform method. Examples and discussion of this method applied to vehicle motion analysis are found in references 4 and 11. Included in these references are methods of presentation and interpretation of results in terms of both the basic variables and the transformed variables.

To illustrate the correspondence between the Laplace transform method and the direct method, the longitudinal small-disturbance equations from table 22 are transformed below. A bar is used over the symbol to denote the transformed variable. For example,

$$\bar{u}'(s) = \mathcal{L}[u'(t)]$$

Applying the Laplace transform to the longitudinal equations from table 22 results in the following transformed equations. The derivatives  $C_{D\dot{q}}$  and  $C_{L\dot{q}}$  are again assumed negligible and initial level flight is used ( $\gamma_0 = 0$ ). The control is considered to be fixed so that  $\delta = 0$ .

$$\left. \begin{aligned} & [2(C_D)_0 + 2\tau s] \bar{u}' + [C_{D\alpha} - (C_L)_0] \bar{\alpha}' + (C_{L\dot{\alpha}})_0 \bar{\theta} = 2\tau u'(0) \\ & 2(C_L)_0 \bar{u}' + [C_{L\alpha} + (C_D)_0 + 2\tau s] \bar{\alpha}' - 2\tau s \bar{\theta} = 2\tau [\alpha'(0) - \theta(0)] \\ & \left[ C_{m\alpha} + C_{m\dot{\alpha}} \frac{\bar{c}}{2V_0} s \right] \bar{\alpha}' + \left[ C_{m\dot{\alpha}} \frac{\bar{c}}{2V_0} s - C_{I_Y} s^2 \right] \bar{\theta} = \\ & C_{m\dot{\alpha}} \frac{\bar{c}}{2V_0} \alpha'(0) + C_{m\dot{\alpha}} \frac{\bar{c}}{2V_0} \theta(0) - C_{I_Y} [\dot{\theta}(0) + s\theta(0)] \end{aligned} \right\} \quad (75)$$

(Notation in the above equations is defined in table 18.)

\*  $\mathcal{R}(\lambda)$  is the real part of the complex number  $\lambda$  and is related to the modulus or amplitude of the vector representation of the number in the complex plane.

$\mathcal{I}(\lambda)$  is the imaginary part of the complex number  $\lambda$  and is related to the angular velocity of the vector representation of the number in the complex plane.

Note the similarity between these equations and those in the preceding Section (equation (72)). The coefficients of the transformed variables are the same as those obtained with the direct method when  $\lambda$  is replaced by  $s$ .

For an undisturbed steady-state condition the terms on the right side of equations (75) are all zero and the trivial case exists. However, if a disturbance such as a control pulse or a gust is introduced, a dynamic motion problem is generated.

Suppose an aircraft in steady level flight encounters a gust. The term  $\alpha' (0^+)^*$  is then different from zero, and the solution of equations (75) for the pitch angle may be expressed in determinant forms. Thus,

$$\bar{\theta}(s) = \frac{\alpha'(0) \begin{vmatrix} [2(C_D)_o + 2\tau s] & [C_{D_\alpha} - (C_L)_o] & 0 \\ [2(C_L)_o] & [C_{L_\alpha} + (C_D)_o + 2\tau s] & [2\tau] \\ 0 & \left[ C_{m_\alpha} + C_{m_\alpha} \frac{\bar{c}}{2V_o} s \right] & C_{m_\alpha} \frac{\bar{c}}{2V_o} \end{vmatrix}}{\begin{vmatrix} [2(C_D)_o + 2\tau s] & [C_{D_\alpha} - (C_L)_o] & [C_L)_o] \\ [2(C_L)_o] & [C_{L_\alpha} + (C_D)_o + 2\tau s] & [-2\tau s] \\ 0 & \left[ C_{m_\alpha} + C_{m_\alpha} \frac{\bar{c}}{2V_o} s \right] & \left[ C_{m_q} \frac{\bar{c}}{2V_o} s - C_{I_Y} s^2 \right] \end{vmatrix}} \quad (76)$$

Expansion of the above determinants results in a quotient of two polynomials in the transformed independent variables. The denominator determinant expands to the characteristic equation of the direct method (see equation (74)).

The solution for the pitch angle  $\theta$  as a function of time requires application of the inverse transformation of  $\theta(s)$ . Thus,

$$\theta(t) = \mathcal{L}^{-1} [\bar{\theta}(s)]$$

In order to simplify the inverse transformation, it is usually expedient to separate the expansion of equation (72) into partial fractions. This procedure then requires finding the roots of the denominator or characteristic equation.

The zeros (roots) of the denominator of equation (76) have the same significance as the roots of the characteristic equation (74) in determining the modes of motion as shown in figure 24.

## MATRIX METHOD OF SOLUTION

A method of solving the equations of motion using matrices is presented in reference 29. This is a procedure more readily adapted to machine computation methods than to analytical methods.

Briefly, the procedure consists of a stepwise integration of the differential equations with a Maclaurin series expansion used in each computation step to achieve any desired degree of accuracy. This method is a rather specialized technique, and the reader is referred to the cited reference for the detailed explanation of the method.

## COMPUTER METHODS OF SOLUTION

The development of modern machine-computing equipment has opened the way for many new and varied analyses to be undertaken. Problems that are impractical to solve by lengthy hand-computation methods are readily computed by high-speed digital computers. Problems that involve nonlinear equations may be solved quickly on an analog computer. The use of machine computation methods also permits more variables (degrees of freedom) to be considered and reduces the number of approximations or assumptions that must be made in order to facilitate solution of a problem. Machine computation methods thus provide a large increase in the amount, scope, and accuracy of analysis possible in many problems.

It is beyond the scope of this report to present a complete discourse on machine-computing methods. The paragraphs that follow provide some general background information and references for detailed treatment of the subject.

\*All of the initial conditions such as  $\alpha'(0)$ ,  $u'(0)$ , etc., occurring on the right side of equations (75) should be interpreted as the value at  $(0 + \epsilon)$  or  $0^+$ .

## DIGITAL COMPUTER

Electronic digital computers have been developed to a very high degree as fast, automatic computing systems. The digital computer is a device that automatically performs the basic operations of arithmetic. It performs these operations in a sequence prescribed by the program for a given problem. Since the digital computer functions as a mechanical desk-type calculator, it is capable of very precise computation (many significant figures). Any problem that can be set up for hand computation can, in principle, be programed for an automatic digital computer.

Reference 30 offers a thorough presentation of the principles and features of digital computers and data processing. The matrix method and the solution of the characteristic equation in the preceding Sections are examples of calculations that may readily be programed for a digital computer. Iterative processes and decision-making routines may be incorporated into a digital program.

The digital computer can perform very complex calculation routines that involve comparison with previously computed or reference data and can then choose a procedure according to one of several alternate subroutines. This is accomplished very rapidly and very precisely. The digital computer is used most advantageously in stability and control calculations for making large numbers of calculations of a given type, such as the response to arbitrary control functions or the dynamic behavior of a flight vehicle with a well-defined automatic control system.

## ANALOG COMPUTER

Analog computers are a combination of electrical and mechanical components. These components are selected and arranged so that the differential equations of the analog system are dual to\* the differential equations for the problem being studied. Electrical components are used in most analog computers. Reference 4 gives a resume of analog components and their basic function. References 30, 31, and 32 are comprehensive texts or handbooks covering the design and application of analog computer systems.

Certain features of analog computers are quite different from those of digital computers. The electrical analog system operates with either the current or the potential in a component circuit representing a variable of the problem being studied: Thus data are continuous and all operations are simultaneous, while the digital computer must follow a prescribed sequence of operations (program) on distinct pieces of data. The accuracy of an analog computer depends upon the precision and quality of its components. Analog computers are generally less accurate than digital computers.

The analog computer has been used extensively in airplane stability and control analysis. It is readily adapted to solving the equations of motion when nonlinear characteristics must be included.

A very useful application of analog computers is the flight simulator, since it can calculate in real time. This device extends the analog simulation to include duplication of the cockpit, controls, and flight instruments. Simulators have been built for many different types of aircraft and used for flight research and for familiarization and training of pilots and flight crews.

## APPROXIMATE SOLUTIONS

Frequently approximate solutions of the equations of motion are useful. Preliminary estimates and quick evaluation of flying qualities often require drastic simplifications of an analysis. The paragraphs that follow present some useful approximate solutions of the equations of vehicle motion.

---

\*Of the same form as.

## APPROXIMATE FORMULAS FOR SMALL-DISTURBANCE MOTION

Relations resulting from approximate solutions of the equations of motion are listed in table 26. These formulas are developed from the small-disturbance equations of motion along stability axes in table 22. Approximate quantitative values for the characteristics of the normal modes of motion are provided by these relations. The information in table 26 is adapted from a similar tabulation in reference 3 and utilizes the notation of table 18.

TABLE 26  
APPROXIMATE FORMULAS FOR SMALL-DISTURBANCE MOTION

		Period (sec)	Damping Ratio	Time Constant (sec)
Longitudinal or Symmetric Modes	Low Frequency Root Pair (Phugoid)	0.138 $V_o$ (fps) or 0.234 $V_o$ (knots)	$\frac{(C_{11})_o}{\sqrt{2} (C_{11})_o}$	—
	High Frequency Root Pair (Short-Period Mode)	$2\pi \sqrt{\frac{C_{I_Y}}{-C_{m_\alpha} - \frac{C_{m_q} \bar{c}}{2V_o} C_{I_\alpha}}}$	$\frac{C_{I_{\alpha r}} C_{I_Y} - 2\tau \frac{\bar{c}}{2V_o} (C_{m_q} + C_{m_\delta} \frac{2V_o}{\bar{c}})}{2 \sqrt{2\tau C_{I_Y} (-2\tau C_{m_\alpha} - C_{I_{\alpha r}} C_{m_q} \frac{\bar{c}}{2V_o})}}$	—
Lateral or Asymmetric Modes	Small Real Root (Spiral Mode)	—	—	$\frac{2\tau (C_{n_\beta} C_{l_p} - C_{l_\beta} C_{n_p})}{(C_{l_1})_o (C_{n_\beta} C_{l_r} - C_{l_\beta} C_{n_r})}$
	Large Real Root (Roll Subsidence)	—	—	$-\frac{C_{l_x}}{C_{l_p} \frac{b}{2V_o}}$
	Root Pair (Dutch Roll)	$2\pi \sqrt{\frac{C_{I_z}}{C_{n_\beta} + \frac{C_{I_{xz}} C_{l_\beta}}{C_{I_z}}}}$	$\frac{-C_{n_r} \frac{b}{2V_o} - \frac{C_{Y_\beta} C_{I_z}}{2\tau}}{2 \sqrt{C_{n_\beta} C_{I_z} + \frac{C_{I_{xz}} C_{I_z} C_{l_\beta}}{C_{I_x}}}}$ <small>(this is a relatively poor approximation)</small>	—

Notation is defined in table 18.

Stability axes are the axes of reference.

Damping ratio is the ratio of damping to critical damping.

## APPROXIMATE FORMULAS FOR RESPONSE TO CONTROL INPUT

Approximate solutions for the response to control input and for maximum accelerations are useful for preliminary estimation and checking of vehicle motion. Several items are included below that provide estimates of response to control deflection, maximum acceleration, and roll rates. Notation for the relations in this Section is given in table 18.

### 1. LOAD FACTOR DUE TO CONTROL DEFLECTION

In horizontal symmetric steady flight the derivative of normal acceleration (load factor) with respect to control deflection is given approximately by

$$\frac{dn}{d\delta} = \frac{V_o}{g} \frac{C_{m_\alpha} C_{z_\delta} - C_{z_\alpha} C_{m_\delta}}{C_{z_r} C_{m_q} \frac{\bar{c}}{2V_o} - C_{n_\alpha} (C_{z_q} \frac{\bar{c}}{2V_o} + 2\tau)} \quad (77)$$

## 2. MAXIMUM ROLL VELOCITY

The maximum-rolling-velocity approximation is obtained from the linearized equation for moments about the X-axis, which is solved for the steady-state, single-degree-of-freedom case. The approximate equation for maximum steady rolling velocity is then

$$\left(\frac{Pb}{2V_0}\right)_{\max} = -\frac{C_{l\delta_a}}{C_{l_p}} \delta_a = -\frac{C_l}{C_{l_p}} \quad (78)$$

## 3. MAXIMUM ANGULAR ACCELERATION

Maximum angular accelerations resulting from control actuation are sometimes needed in aircraft design work. A simple relation for maximum angular acceleration is given below.

First it is assumed that the applied moment coefficient is represented by the function illustrated in the sketch below.

A single-degree-of-freedom approximation may be used; however, static stability is neglected in the case of yawing and pitching motion. Under these conditions the maximum angular acceleration occurs at  $t = t_1$  and is given for the rolling case by the equation

$$\dot{p}_{\max} = \frac{C_{l_v}}{C_{l_p} t_1} \left[ e^{\frac{C_{l_p} t_1}{C_{l_x}}} - 1 \right] \quad (79)$$

Similarly, the equations for maximum pitching and yawing accelerations are

$$\dot{q}_{\max} = \frac{C_{m_o}}{C_{m_q} t_1} \left[ e^{\frac{C_{m_q} t_1}{C_{l_y}}} - 1 \right] \quad (80)$$

$$\dot{r}_{\max} = \frac{C_{n_o}}{C_{n_r} t_1} \left[ e^{\frac{C_{n_r} t_1}{C_{l_z}}} - 1 \right] \quad (81)$$

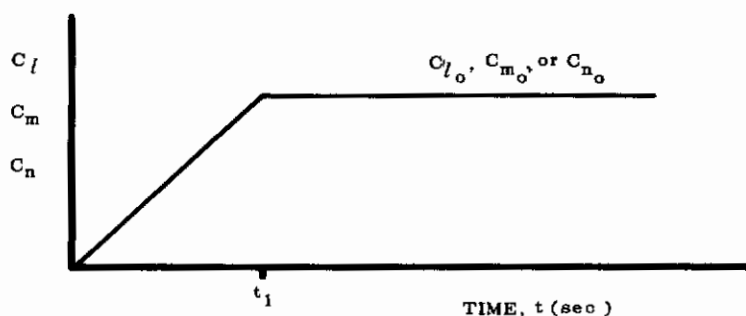

## SECTION 7. SPECIAL PROBLEMS

### INSTRUMENT READINGS

In the analysis and the automatic control of vehicle motion it is frequently desirable — or even necessary — to utilize several types of instrumentation. Instruments may be used to indicate the attitude of a vehicle or to measure velocity and acceleration components.

The following Sections present relations and equations that are useful in the resolution and interpretation of instrument readings. These relations are adapted from references 9 and 19.

#### ATTITUDE-MEASURING INSTRUMENT READINGS

Vehicle attitude is usually determined from a system of gyro instruments. The rotation angles of the instrument about the inner and outer gimbal axes are related to the vehicle orientation angles  $\Psi$ ,  $\Theta$ , and  $\Phi$ . The conventional free vertical and directional gyro system is shown in figure 25.

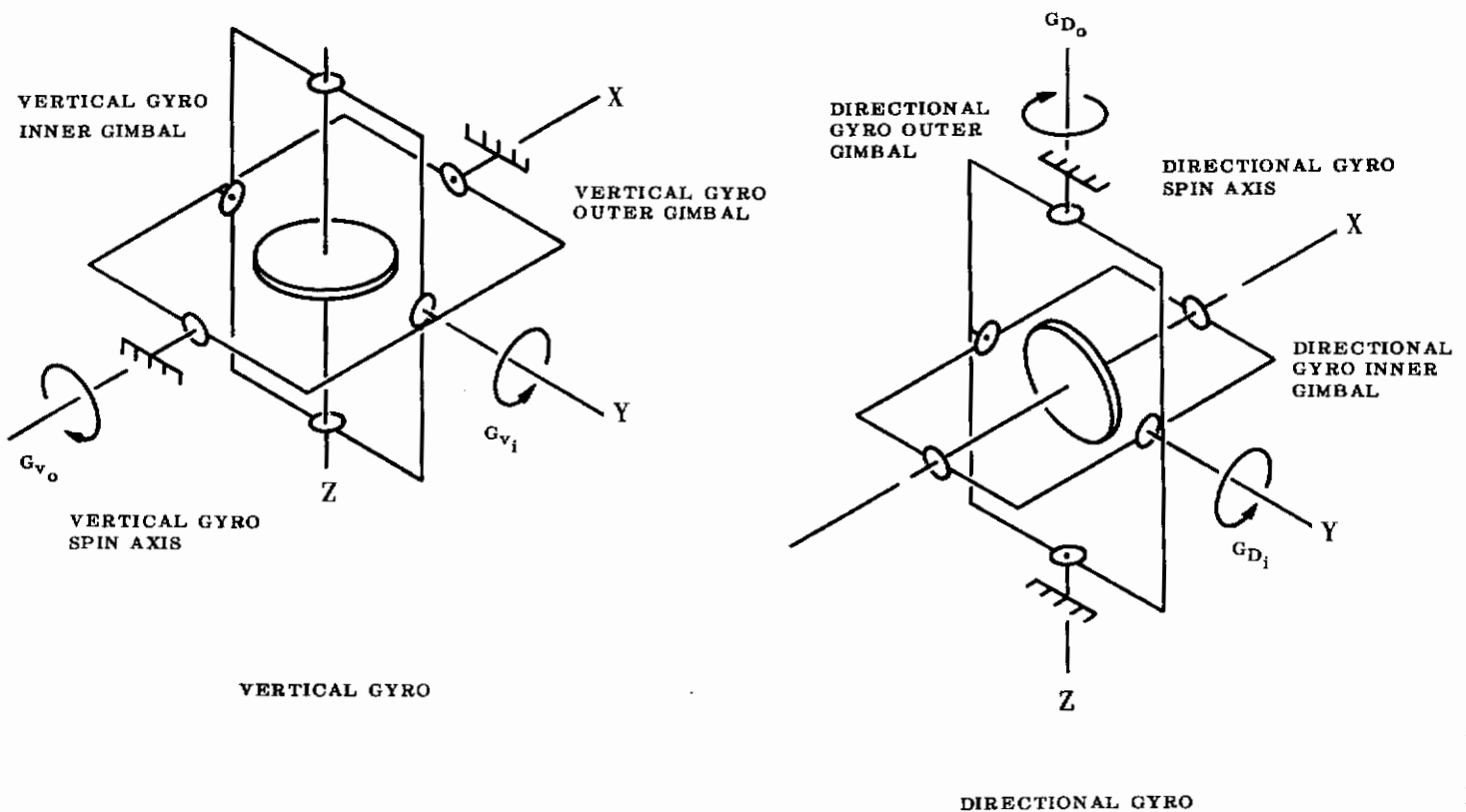

FIGURE 25 CONVENTIONAL FREE VERTICAL AND DIRECTIONAL GYRO SYSTEMS

From the above figure and the relations for the orientation of vehicle body axes, figure 19 and table 11, the gyro equations below are developed.

## Vertical Gyro

$$\left. \begin{aligned} G_{V_i} &= \sin^{-1} (\cos \epsilon_I \sin \Theta + \sin \epsilon_I \cos \Phi \cos \Theta) \\ G_{V_o} &= \tan^{-1} \left( \frac{\sin \Phi \cos \Theta}{\cos \epsilon_I \cos \Phi \cos \Theta - \sin \epsilon_I \sin \Theta} \right) \end{aligned} \right\} \quad (82)$$

## Directional Gyro

$$\left. \begin{aligned} G_{D_i} &= \sin^{-1} [\cos \epsilon_I (\cos \Psi \cos \Phi \sin \Theta + \sin \Psi \sin \Phi) + \sin \epsilon_I \cos \Psi \cos \Theta] \\ G_{D_o} &= \tan^{-1} \left[ \frac{\sin \Psi \cos \Phi - \sin \Phi \sin \Theta \cos \Psi}{\cos \epsilon_I \cos \Theta \cos \Psi - \sin \epsilon_I (\sin \Psi \sin \Phi + \cos \Psi \cos \Phi \sin \Theta)} \right] \end{aligned} \right\} \quad (83)$$

where

$G_{V_i}, G_{D_i}$  are rotation angles about the inner gimbal axes of the vertical and directional gyros, respectively.

$G_{V_o}, G_{D_o}$  are the rotation angles about the outer gimbal axes of the vertical and directional gyros, respectively.

$\epsilon_I$  is the angle between the outer gimbal axis of the vertical gyro and the vehicle X-axis (this is also the angle between the vehicle Z-axis and the directional gyro outer gimbal axis). The subscript I denotes reference to instrument axes.

$\Psi, \Theta, \Phi$  are the orientation angles of the vehicle body axes as defined on page 11.

The gyro systems shown in figure 25 and analyzed in equations (82) and (83) are for the most simple form of free gyro. More complex attitude- and direction-sensing instrumentation is used in many advanced vehicles. The output indications of gyro-instrumented stable platforms in terms of vehicle attitude are derived in reference 33. The attitude output signals of other fire-control and navigational devices are discussed in references 34, 35, and 36.

## VELOCITY-MEASURING INSTRUMENT READINGS

Velocity components are generally measured by instruments that are not located at the vehicle center of gravity. In addition, the orientation of these instruments may not coincide with the vehicle-orientation reference axes (body axes). Thus, even after instrument errors and position errors (sidewash, upwash, etc.) are accounted for, the velocity components of the vehicle center of gravity are not given directly by these instruments.

A general set of instrument axes may be used having its origin located by a vector  $\mathbf{r}$  from the vehicle center of gravity. These axes may be oriented with respect to the vehicle body axes system by the angles  $\psi_I, \theta_I,$  and  $\phi_I$  as indicated in figure 26.

The velocity vector on instrument axes is given by the equation

$$\mathbf{V}_I = \mathbf{V} + \boldsymbol{\omega} \times \mathbf{r} \quad (84)$$

In this equation the separate vectors are given by the relations

$$\left. \begin{aligned} \mathbf{V}_I &= U_I \mathbf{i}_I + V_I \mathbf{j}_I + W_I \mathbf{k}_I && \text{(Instrument velocity)} \\ \mathbf{V} &= U \mathbf{i} + V \mathbf{j} + W \mathbf{k} && \text{(Vehicle linear velocity)} \\ \boldsymbol{\omega} &= P \mathbf{i} + Q \mathbf{j} + R \mathbf{k} && \text{(Vehicle angular velocity)} \\ \mathbf{r} &= x \mathbf{i} + y \mathbf{j} + z \mathbf{k} && \text{(Instrument location vector)} \end{aligned} \right\} \quad (85)$$

The general notation in these equations is defined on page 9, and the subscript 1 denotes instrument axes. Expressing equation (84) in Cartesian form and applying the transformation matrix for Case I of table 2 to describe the orientation of the instrument axes results in the equations below for the velocity components along instrument axes.

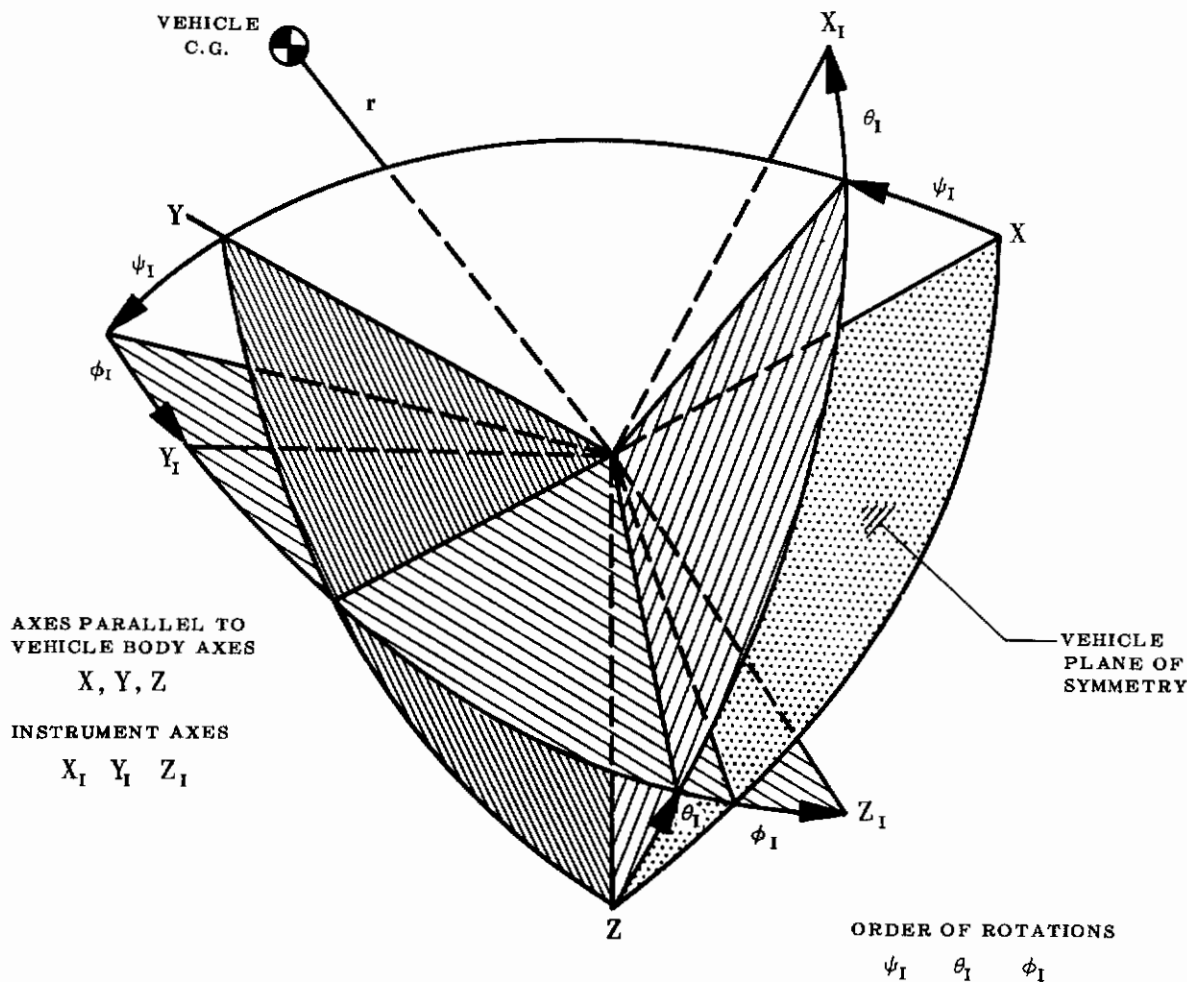

FIGURE 26 GENERAL INSTRUMENT AXES

$$\left. \begin{aligned}
 U_I &= (U - Ry + Qz) \cos \theta_I \cos \psi_I + (V - Pz + Rx) \cos \theta_I \sin \psi_I - (W - Qx + Py) \sin \theta_I \\
 V_I &= (U - Ry + Qz) (\cos \psi_I \sin \phi_I \sin \theta_I - \sin \psi_I \cos \phi_I) \\
 &\quad + (V - Pz + Rx) (\sin \psi_I \sin \phi_I \sin \theta_I + \cos \psi_I \cos \phi_I) \\
 &\quad + (W - Qx + Py) \sin \phi_I \cos \theta_I \\
 W_I &= (U - Ry + Qz) (\cos \psi_I \cos \phi_I \sin \theta_I + \sin \psi_I \sin \phi_I) \\
 &\quad + (V - Pz + Rx) (\sin \psi_I \cos \phi_I \sin \theta_I - \cos \psi_I \sin \phi_I) \\
 &\quad + (W - Qx + Py) \cos \theta_I \cos \phi_I
 \end{aligned} \right\} \quad (86)$$

The foregoing equations can be greatly simplified for most cases of interest. Usually  $\psi_I$  and  $\phi_I$  will be zero and certain of the distances  $x$ ,  $y$ , and  $z$  may be negligible. Also the limitation to small disturbances permits the following simplification of the expressions for the angles of attack and sideslip, respectively.



$$\left. \begin{aligned} \alpha_1 &= \tan^{-1} \left( \frac{\dot{W}_1}{\dot{U}_1} \right) \approx \frac{W_1}{U_1} \\ \beta_1 &= \tan^{-1} \left( \frac{\dot{V}_1}{\dot{U}_1} \right) \approx \frac{V_1}{U_1} \end{aligned} \right\} \quad (87)$$

**ACCELERATION-MEASURING INSTRUMENT READINGS**

The acceleration-measuring instruments are located and oriented in much the same way as the velocity instruments, i.e., displaced from the vehicle center of gravity. Therefore the instrument accelerations must be related to the vehicle center-of-gravity acceleration.

Linear accelerations along instrument axes are given by the equation

$$\dot{\mathbf{V}}_1 = \dot{\mathbf{V}} + \boldsymbol{\omega} \times \mathbf{V} + \dot{\boldsymbol{\omega}} \times \mathbf{r} + \boldsymbol{\omega} \times (\boldsymbol{\omega} \times \mathbf{r}) \quad (88)$$

The vectors, in addition to those given in equation (85), are expressed below.

$$\left. \begin{aligned} \dot{\mathbf{V}}_1 &= \dot{U}_1 \mathbf{i}_1 + \dot{V}_1 \mathbf{j}_1 + \dot{W}_1 \mathbf{k}_1 && \text{(Instrument acceleration)} \\ \dot{\mathbf{V}} &= \dot{U} \mathbf{i} + \dot{V} \mathbf{j} + \dot{W} \mathbf{k} && \text{(Vehicle linear acceleration)} \\ \dot{\boldsymbol{\omega}} &= \dot{P} \mathbf{i} + \dot{Q} \mathbf{j} + \dot{R} \mathbf{k} && \text{(Vehicle angular acceleration)} \end{aligned} \right\} \quad (89)$$

Acceleration components along instrument axes are expressed below. These equations are obtained from equation (88) and Case 1 of table 2. The general notation is defined on page 9, and the subscript 1 denotes quantities referred to instrument axes.

$$\left. \begin{aligned} \dot{U}_1 &= [\dot{U} - RV + QW - x(R^2 + Q^2) + y(PQ - \dot{R}) + z(RP + \dot{Q})] \cos \theta_1 \cos \psi_1 \\ &+ [\dot{V} - PW + RU + x(PQ + \dot{R}) - y(P^2 + R^2) + z(QR - \dot{P})] \cos \theta_1 \sin \psi_1 \\ &- [\dot{W} - QU + PV + x(PR - \dot{Q}) + y(QR + \dot{P}) - z(Q^2 + P^2)] \sin \theta_1 \\ \dot{V}_1 &= [\dot{U} - RV + QW - x(R^2 + Q^2) + y(PQ - \dot{R}) + z(RP + \dot{Q})] (\cos \psi_1 \sin \phi_1 \sin \theta_1 - \sin \psi_1 \cos \phi_1) \\ &+ [\dot{V} - PW + RU + x(PQ + \dot{R}) - y(P^2 + R^2) + z(QR - \dot{P})] (\sin \psi_1 \sin \phi_1 \sin \theta_1 + \cos \psi_1 \cos \phi_1) \\ &+ [\dot{W} - QU + PV + x(PR - \dot{Q}) + y(QR + \dot{P}) - z(Q^2 + P^2)] \sin \phi_1 \cos \theta_1 \\ \dot{W}_1 &= [\dot{U} - RV + QW - x(R^2 + Q^2) + y(PQ - \dot{R}) + z(RP + \dot{Q})] (\cos \psi_1 \cos \phi_1 \sin \theta_1 + \sin \psi_1 \sin \phi_1) \\ &+ [\dot{V} - PW + RU + x(PQ + \dot{R}) - y(P^2 + R^2) + z(QR - \dot{P})] (\sin \psi_1 \cos \phi_1 \sin \theta_1 - \cos \psi_1 \sin \phi_1) \\ &+ [\dot{W} - QU + PV + x(PR - \dot{Q}) + y(QR + \dot{P}) - z(Q^2 + P^2)] \cos \theta_1 \cos \phi_1 \end{aligned} \right\} \quad (90)$$

The above relations can be simplified in most instances, as was the case with the previous velocity component equations. There are, however, additional factors to be considered in acceleration-measuring devices. These factors are

1. Effect of gravity force on suspended or pivoted mass (seismic element).
2. The dynamics of the device itself; the instrument has spring and damping forces acting on the suspended mass.
3. The effect of angular acceleration of the instrument mounting, when a pivoted mass is used.

Detailed analyses of the above items are beyond the scope of the present report. The reader is referred to the presentations in references 19 and 37 for these details.

## FUEL SLOSH

Fuel slosh within partially filled tanks is known to affect the dynamics of manned aircraft and missiles. Fuel slosh introduces additional degrees of freedom, owing to the relative motion of the fuel mass and the airframe. This Section of the report is concerned with the effects of fuel slosh on the rigid-body modes of vehicle motion. The literature on fuel slosh contains numerous references to the effect of fuel slosh on the flutter problem. The latter is not treated here. Furthermore, in some applications, such as flexible boosters for large ballistic missiles or space vehicles, fuel-slosh, rigid-body, and body-bending effects may all be inseparably coupled. The approach described in this Section would obviously require extensions to include the effects of structural flexibility in such cases.

### CONDITIONS UNDER WHICH FUEL SLOSH HAS BEEN FOUND TO BE SIGNIFICANT

The addition of fuel-slosh degrees of freedom to the equations of vehicle motion complicates the analysis, as may be seen subsequently. As a guide to the need for this complication, a brief summary is presented in table 27 of conditions under which fuel-slosh effects have been found to be significant.

TABLE 27

SOME CONDITIONS UNDER WHICH FUEL SLOSH HAS SIGNIFICANT EFFECTS ON VEHICLE RIGID-BODY MODES OF MOTION

$\frac{\text{Fuel Mass}}{\text{Total Mass}}$	Fuel-Tank Location	Fuel-Tank Shape	Fuel-Slosh Natural Frequency	Vehicle Rigid-Body Mode* Affected	Remarks	Ref
> 0.25	Forward of Vehicle c.g.	Any	Approximately equal to rigid-body mode	Lateral-directional (Dutch-Roll) oscillation	The mode damping is reduced in this case. Unstable roots can appear, leading to a limit cycle (snaking)	38
> 0.10	Any	Large spanwise dimension	Not applicable	Spiral mode, in horizontal flight	Spiral divergence occurs, as if the vehicle had negative dihedral. The long-term response to directional control is reversed	38
> 0.10	Any	Large longitudinal dimension	Approximately equal to rigid-body mode	Long-period (phugoid) oscillation, in horizontal flight	The mode damping is reduced in this case	39
> 0.25	Forward of vehicle c.g.	Any	Approximately equal to rigid-body mode	Yaw or pitch oscillation in low-speed vertical flight, as for rocket take-off	The mode damping is reduced	..

\*See page 84.

As is implied in table 27, fuel-slosh coupling with the short-period longitudinal mode of rigid-body motion is usually negligible in horizontal flight. Fuel-slosh effects may be neglected in studies of this mode. Coupling exists, of course, for this mode of motion in vertical flight, as in the take-off phase of many liquid-fueled, rocket-powered vehicles.

The steady-state relationship between fuel mass center shift and fuel-tank acceleration for closed-top rectangular fuel tanks is given in reference 38. These results show that only slight tank accelerations can produce near-maximum fuel mass center shifts, in many practical cases. As an example, for a typical height-to-length ratio of 0.08 for a wing fuel tank, 80 percent of the maximum possible fuel mass shift is attained for a lateral acceleration of 0.1 g, with the tank half full.

It is concluded that the coupled motions of the airframe and sloshing fuel masses are generally significant for small disturbances. For large vehicle disturbances, involving large values of fuel-tank acceleration in a horizontal plane, sloshing fuel tends to act as an off-center fixed mass, without dynamic coupling to the airframe, or with discontinuous coupling.

## MOTION OF SLOSHING FUEL

In the analysis of fuel-slosh effects on vehicle flight dynamics, sloshing fuel masses are generally represented as mass-spring-damper single-degree-of-freedom dynamic elements. The natural frequencies of the analog elements correspond to the lowest or fundamental modes of fuel slosh.

More complex analogs could be constructed to represent higher frequency fuel-slosh modes in addition to the fundamental mode. The forces applied to the airframe by the higher frequency modes of fuel slosh are relatively small. As a general rule, only the fundamental mode is represented in practice.

Available data on the fundamental-mode natural frequencies for several tank-shapes are summarized in figure 28. The data in this figure are in dimensionless form. For convenience, an auxiliary chart is presented as figure 29, for the fundamental-mode natural frequencies of open-top rectangular tanks, in terms of physical dimensions.

Available data on the forces applied to the airframe by sloshing fuel is more limited at present than the corresponding data for natural frequency. For the purpose of this report, the applied-force data are presented in terms of the "effective" fuel mass. The effective fuel mass  $m_f$  is defined in relation to the single-degree-of-freedom analog of figure 27. If the actual fuel tank and the analog are given the same horizontal and rotational motions, the effective fuel mass  $m_f$ , equal to the concentrated mass in the analog, provides the same reactions on the container (acting through the spring and damper) as the reactions on the fuel tank applied by the sloshing fuel.

For reference, open-top rectangular data of figure 30 were developed from the equivalent pendulum concept of reference 40. Evaluation of the transfer function relating applied force to linear and rotational input tank motions showed that the effective fuel mass  $m_f$  is equal to the equivalent pendulum mass of reference 40.

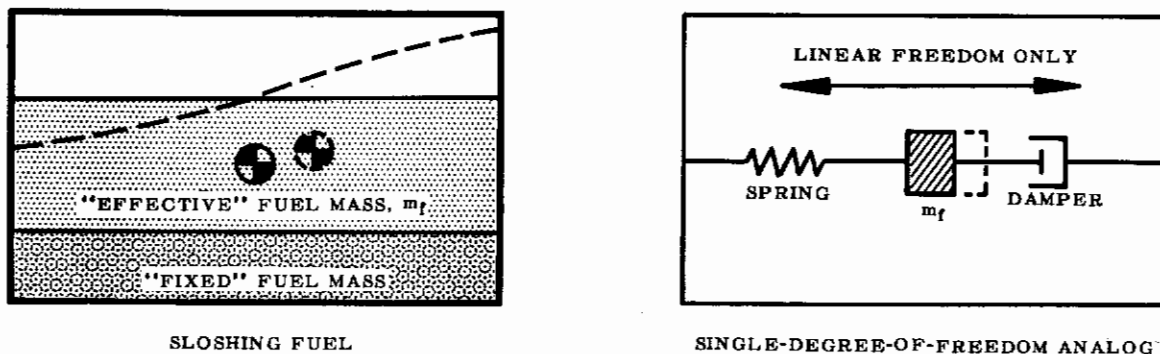
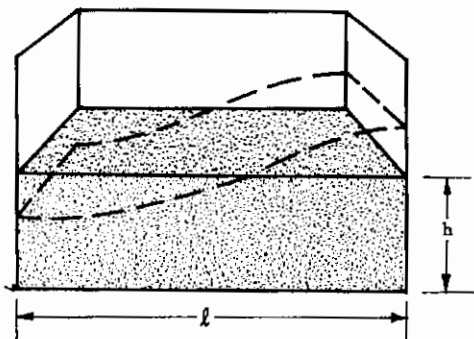
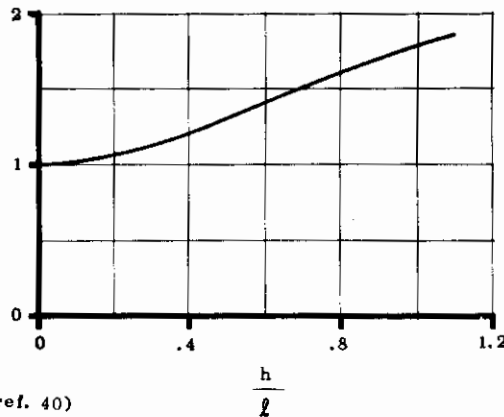

FIGURE 27 SINGLE-DEGREE-OF-FREEDOM ANALOG TO SLOSHING FUEL



$$\frac{P \sqrt{gh}}{2l}$$



OPEN-TOP RECTANGULAR TANK (ref. 40)

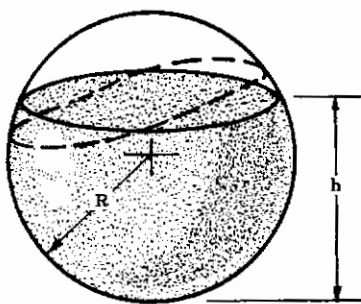

SPHERICAL TANK (ref. 41)

$$\omega \eta \sqrt{\frac{R}{g}}$$

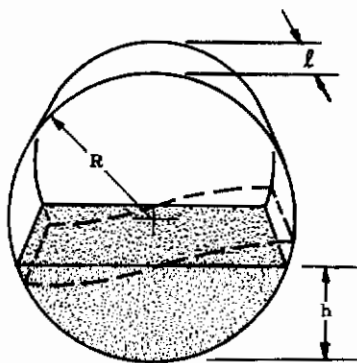
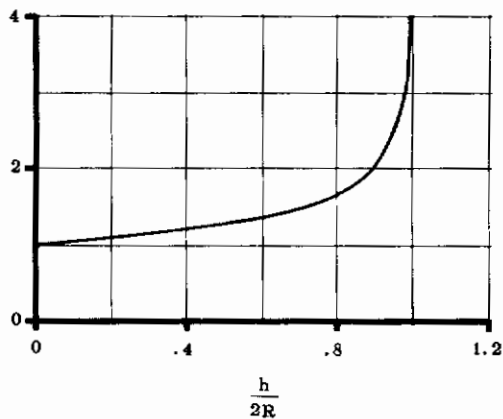

$$\omega \eta \sqrt{\frac{R}{g}}$$

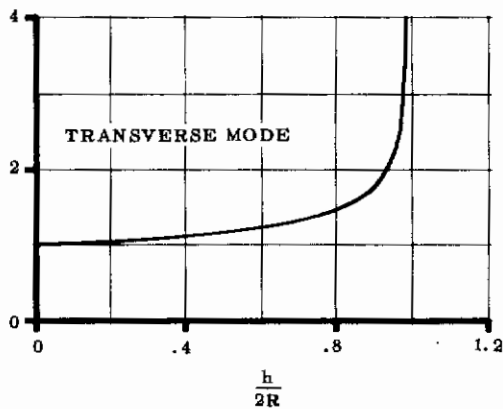
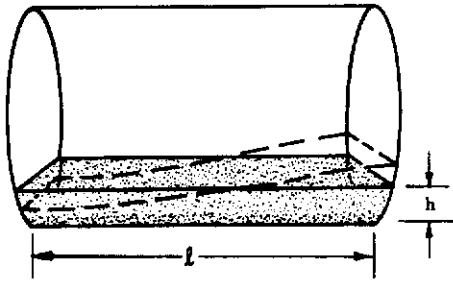
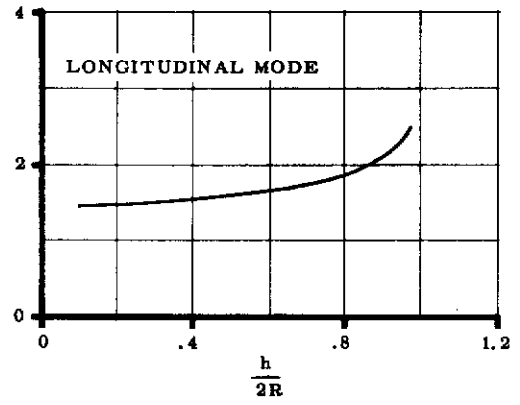

FIGURE 28 NATURAL FREQUENCY OF FUEL-SLOSH FUNDAMENTAL MODE FOR VARIOUS FUEL-TANK SHAPES



$$\omega \eta \sqrt{\frac{l/g}{\tanh \frac{\pi h}{l}}}$$



HORIZONTAL CIRCULAR CYLINDRICAL TANK (ref. 40)

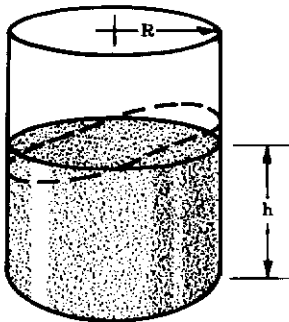

$$\omega \eta \sqrt{\frac{R/g}{5.168 \tanh \frac{h}{R}}}$$

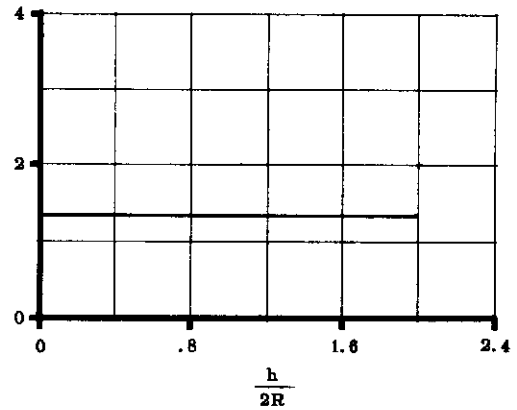

UPRIGHT CIRCULAR CYLINDRICAL TANK (ref. 41)

FIGURE 28 (CONTD.)

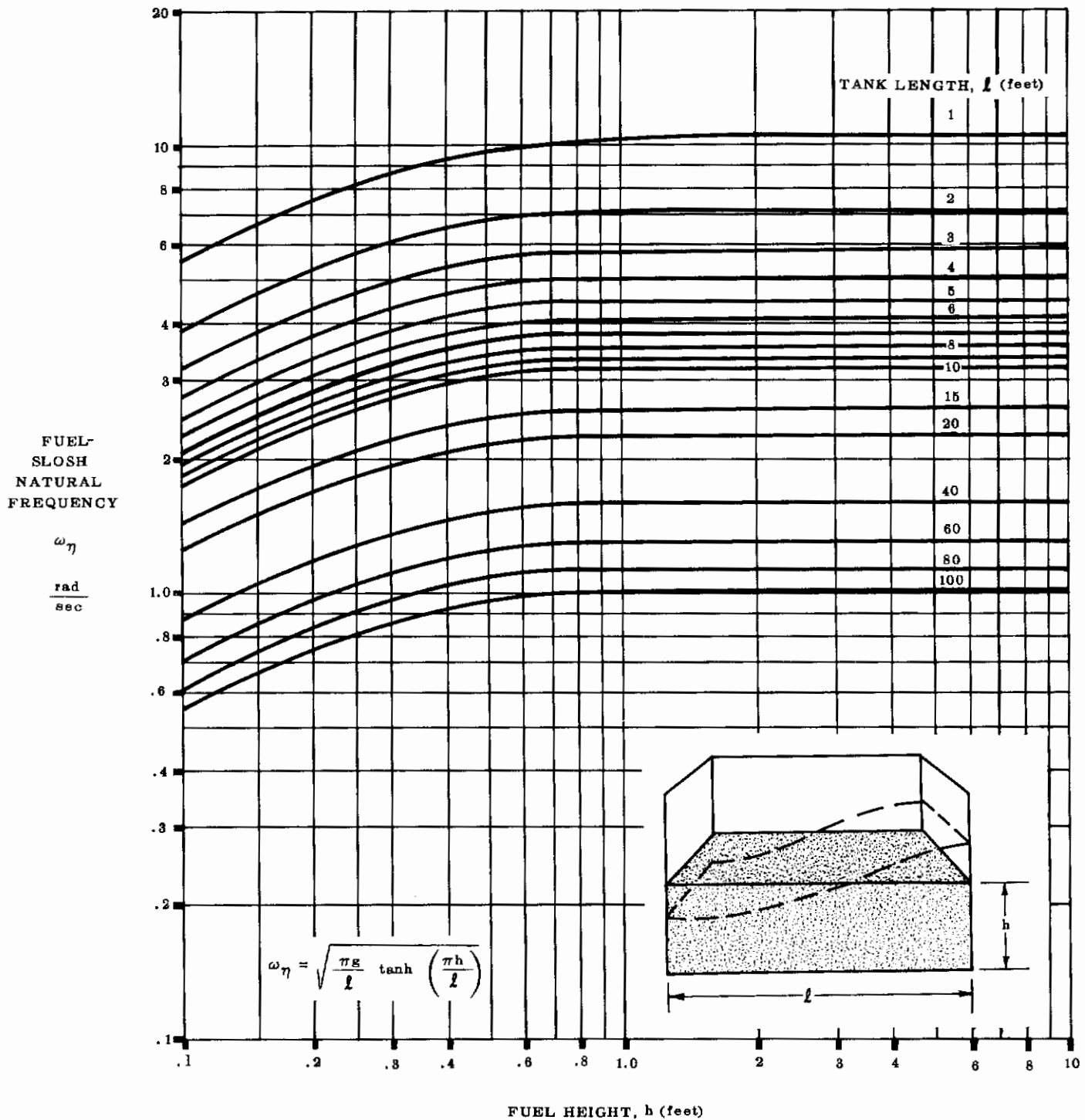
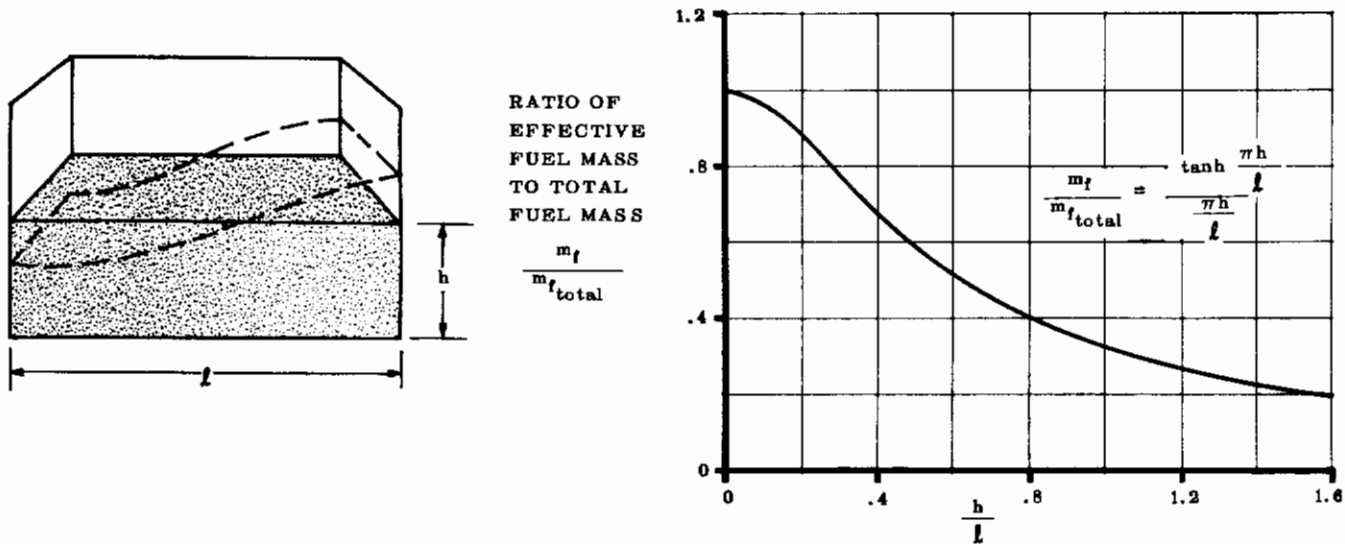

FIGURE 29 NATURAL FREQUENCY OF FUEL SLOSH IN OPEN-TOP RECTANGULAR FUEL TANKS (IN TERMS OF PHYSICAL DIMENSIONS)



SPHERICAL TANK



HORIZONTAL CIRCULAR CYLINDRICAL TANK TRANSVERSE MODE

$$\frac{m_f}{m_{f_{total}}} = 1.0$$

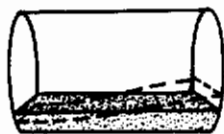

HORIZONTAL CIRCULAR CYLINDRICAL TANK LONGITUDINAL MODE



UPRIGHT CIRCULAR CYLINDRICAL TANK

AS AN APPROXIMATION, USE THE RESULTS ABOVE FOR OPEN-TOP RECTANGULAR TANKS, WITH  $l = 2R$  FOR THE UPRIGHT CIRCULAR CYLINDRICAL TANK

FIGURE 30 EFFECTIVE MASS OF FUEL SLOSH FUNDAMENTAL MODE FOR VARIOUS FUEL-TANK SHAPES

## REFERENCES

1. Kevorkian, J. D. "Equations of Motion for an Atmospheric Quasi-Orbital Vehicle and Some Numerical Solutions." Douglas Aircraft Company Report, LB 35389, 1958.
2. Klein, H. "Some Notes on the Dynamics of Trajectories." Douglas Aircraft Company Report, SM23288, 1959.
3. Abzug, M. J., and Thorndike, C. S. "Lectures on Airplane Dynamics—Symbols, Tables, and Figures." Douglas Aircraft Company Report, ES26986, 1958.
4. Etkin, B. Dynamics of Flight. Wiley & Sons, 1959.
5. Charters, A. C. "The Linearized Equations of Motion Underlying the Dynamic Stability of Aircraft, Spinning Projectiles, and Symmetrical Missiles." NACA TN 3350, 1955.
6. Goldstein, M. Classical Mechanics. Addison & Wesley, 1951.
7. Durand, W. F. Aerodynamic Theory. Vol. V. Springer, 1934.
8. Frazer, R. A., Duncan, W. J., and Collar, A. R. Elementary Matrices. Cambridge University Press, 1938.
9. Abzug, M. J. "Kinematics and Dynamics of Fully Maneuvering Airplanes." Douglas Aircraft Company Report, ES 16144, 1952.
10. Doolin, B. F. "The Application of Matrix Methods to Coordinate Transformations Occurring in Systems Studies Involving Large Motions of Aircraft." NACA TN 3968, 1957.
11. Anon. "Dynamics of the Airframe." BuAer Report AE-61-4 II, 1953.
12. Pope, A. Wind Tunnel Testing. Wiley & Sons, 1954.
13. Ellison, D. E., and Malthan, L. V. "USAF Stability and Control DATCOM." October, 1960. (Rev. July, 1963)
14. Statler, I. C. "Dynamic Stability at High Speeds from Unsteady Flow Theory." Jour. Aero. Sci., April 1950.
15. Perkins, C. D., and Hage, R. E. Airplane Performance Stability and Control. Wiley, 1949.
16. Larrabee, E. E. Unpublished Massachusetts Institute of Technology Lecture Notes—Used by permission.
17. Fischer, L. R. "Experimental Determination of the Effects of Frequency and Amplitude of Oscillation on the Roll-Stability Derivatives for a 60° Delta-Wing Airplane Model." NASA TN D-232, 1960.
18. Campbell, J. P., and Woodling, C. H. (UNCLASSIFIED TITLE) "Calculated Effects of the Lateral Acceleration Derivatives on the Dynamic Lateral Stability of a Delta-Wing Airplane." NACA RM L54-K26, 1955. (CONFIDENTIAL REPORT)
19. Abzug, M. J. "Equations of Airplane Motion for Large Disturbances from Steady Flight." Douglas Aircraft Company Report, ES 17935, 1955.
20. Phillips, W. H. "Effect of Steady Rolling on Longitudinal and Directional Stability." NACA TN 1627, 1948.
21. Klinor, W. J., and Grantham, W. D. "Investigation of the Stability of Very Flat Spins and Analysis of Effects of Applying Various Moments Utilizing the Three Moment Equations of Motion." NASA Memo 5-25-59L, 1959.
22. Abzug, M. J. "Effects of Certain Steady Motions on Small Disturbance Airplane Dynamics." Jour. Aero. Sci., November 1954.



23. Steinfield, L. "A Simplified Method for Approximating the Transient Motion in Angle of Attack and Sideslip During a Constant Rolling Maneuver." NACA TN 1344, 1958.
24. Bratt, R. W., and DaRos, C. J. "A Simplified Analysis of Inertial Coupling of a Rolling Airplane." A paper presented at WADC Conference on Inertial Coupling of Aircraft, February 1956. Also Douglas Aircraft Company Report, ES 26513.
25. Shinbrot, M. "On the Analysis of Linear and Nonlinear Dynamical Systems from Transient-Response Data." NACA TN 3288, 1954.
26. Robinson, A. C. "On the Use of Quaternions in Simulation of Rigid Body Motion." Eastern Joint Computer Conference, December 12, 1957.
27. Gardiner, M. F., and Barnes, J. L. Transients in Linear Systems. Wiley, 1942.
28. Pipes, L. A. Applied Mathematics for Engineers and Physicists. McGraw-Hill, 1946.
29. Abzug, M. J. "Applications of Matrix Operators to the Kinematics of Airplane Motion." Jour. Aero. Sci., July 1956.
30. Grabbe, E. M., Ramo, S., and Wooldridge, D. E. Handbook of Automation, Computation and Control. Vol. 2. Computers and Data Processing, Wiley, 1959.
31. Korn, G. A., and Korn, T. M. Electronic Analogue Computers. McGraw-Hill, 1952.
32. Soroka, W. W. Analogue Methods in Computation and Simulation. McGraw-Hill, 1954.
33. Gorczycki, E. "Dynamic Considerations Relating to the Behavior of Inertial Space-Stabilized Platforms." Jour. Aero. Sci., February 1957.
34. Lange, A. S. "Automatic Control of Three-Dimensional Vector Quantities—Part 1." Inst. of Radio Engr. Trans. on Automatic Control, Vol. AC-4, No. 1, pp 21–30, May 1959.
35. Lange, A. S. "Automatic Control of Three-Dimensional Vector Quantities—Part 2." Inst. of Radio Engr. Trans. on Automatic Control, Vol. AC-5, No. 1, pp 38–57, January 1960.
36. Lange, A. S. "Automatic Control of Three-Dimensional Vector Quantities—Part 3." Inst. of Radio Engr. Trans. on Automatic Control, Vol. AC-5, No. 2, pp 106–117, June 1960.
37. Abzug, M. J. "Aircraft Accelerometer Theory." Douglas Aircraft Company Report, ES 17297, 1953.
38. Abzug, M. J. "Effects of Fuel Slosh on Stability and Control." Douglas Aircraft Company Report, ES 29551, 1959.
39. Luskin, H., and Lapin, E. "An Analytical Approach to the Fuel Sloshing and Buffeting Problems of Aircraft." Jour. Aero. Sci. Vol. 19, No. 4, April 1952.
40. Graham, E. W. "The Forces Produced by Fuel Oscillation in a Rectangular Tank." Douglas Aircraft Company Report, SM 13748, 1950.
41. Lamb, H. Hydrodynamics. Sixth Edition, Dover Publications, 1945.

# *Contrails*

Unclassified

Security Classification

DOCUMENT CONTROL DATA - R&D		
<i>(Security classification of title, body of abstract and indexing annotation must be entered when the overall report is classified)</i>		
1. ORIGINATING ACTIVITY (Corporate author) Douglas Aircraft Co., Inc. Long Beach, Calif.		2a. REPORT SECURITY CLASSIFICATION Unclassified
		2b. GROUP
3. REPORT TITLE AIRCRAFT MOTION ANALYSIS		
4. DESCRIPTIVE NOTES (Type of report and inclusive dates)		
5. AUTHOR(S) (Last name, first name, initial) Thelander, J.A.		
6. REPORT DATE March 1965	7a. TOTAL NO. OF PAGES 100	7b. NO. OF REFS 41
8a. CONTRACT OR GRANT NO. AF33(616)-6460	9a. ORIGINATOR'S REPORT NUMBER(S) FDL TDR 64-70	
b. PROJECT NO. 8219	9b. OTHER REPORT NO(S) (Any other numbers that may be assigned this report)	
c. Task 821902		
d.		
10. AVAILABILITY/LIMITATION NOTICES Qualified requesters may obtain copies of this report from DDC. This report has been released to the OTS for sale to the general public.		
11. SUPPLEMENTARY NOTES	12. SPONSORING MILITARY ACTIVITY AFFDL (FDCC) Wright-Patterson AFB, Ohio 45433	
13. ABSTRACT This report is a compilation of coordinate systems, equations and general relations used in aircraft motion analysis. The information presented is useful for comparative evaluation and for preliminary-design work. Simplified and approximate solutions are given for special flight conditions. The material is defined and presented in a form suitable for direct application. Derivation and theoretical development are not emphasized, but sources thereof are named.		

DD FORM 1473  
1 JAN 64

Unclassified  
Security Classification

Unclassified  
Security Classification

14.	KEY WORDS	LINK A		LINK B		LINK C	
		ROLE	WT	ROLE	WT	ROLE	WT
	stability derivatives  dynamic analysis  equations of motion  coordinate systems						

**INSTRUCTIONS**

1. **ORIGINATING ACTIVITY:** Enter the name and address of the contractor, subcontractor, grantee, Department of Defense activity or other organization (*corporate author*) issuing the report.
- 2a. **REPORT SECURITY CLASSIFICATION:** Enter the overall security classification of the report. Indicate whether "Restricted Data" is included. Marking is to be in accordance with appropriate security regulations.
- 2b. **GROUP:** Automatic downgrading is specified in DoD Directive 5200.10 and Armed Forces Industrial Manual. Enter the group number. Also, when applicable, show that optional markings have been used for Group 3 and Group 4 as authorized.
3. **REPORT TITLE:** Enter the complete report title in all capital letters. Titles in all cases should be unclassified. If a meaningful title cannot be selected without classification, show title classification in all capitals in parenthesis immediately following the title.
4. **DESCRIPTIVE NOTES:** If appropriate, enter the type of report, e.g., interim, progress, summary, annual, or final. Give the inclusive dates when a specific reporting period is covered.
5. **AUTHOR(S):** Enter the name(s) of author(s) as shown on or in the report. Enter last name, first name, middle initial. If military, show rank and branch of service. The name of the principal author is an absolute minimum requirement.
6. **REPORT DATE:** Enter the date of the report as day, month, year, or month, year. If more than one date appears on the report, use date of publication.
- 7a. **TOTAL NUMBER OF PAGES:** The total page count should follow normal pagination procedures, i.e., enter the number of pages containing information.
- 7b. **NUMBER OF REFERENCES:** Enter the total number of references cited in the report.
- 8a. **CONTRACT OR GRANT NUMBER:** If appropriate, enter the applicable number of the contract or grant under which the report was written.
- 8b, 8c, & 8d. **PROJECT NUMBER:** Enter the appropriate military department identification, such as project number, subproject number, system numbers, task number, etc.
- 9a. **ORIGINATOR'S REPORT NUMBER(S):** Enter the official report number by which the document will be identified and controlled by the originating activity. This number must be unique to this report.
- 9b. **OTHER REPORT NUMBER(S):** If the report has been assigned any other report numbers (*either by the originator or by the sponsor*), also enter this number(s).
10. **AVAILABILITY/LIMITATION NOTICES:** Enter any limitations on further dissemination of the report, other than those

imposed by security classification, using standard statements such as:

- (1) "Qualified requesters may obtain copies of this report from DDC."
- (2) "Foreign announcement and dissemination of this report by DDC is not authorized."
- (3) "U. S. Government agencies may obtain copies of this report directly from DDC. Other qualified DDC users shall request through \_\_\_\_\_."
- (4) "U. S. military agencies may obtain copies of this report directly from DDC. Other qualified users shall request through \_\_\_\_\_."
- (5) "All distribution of this report is controlled. Qualified DDC users shall request through \_\_\_\_\_."

If the report has been furnished to the Office of Technical Services, Department of Commerce, for sale to the public, indicate this fact and enter the price, if known.

11. **SUPPLEMENTARY NOTES:** Use for additional explanatory notes.

12. **SPONSORING MILITARY ACTIVITY:** Enter the name of the departmental project office or laboratory sponsoring (*paying for*) the research and development. Include address.

13. **ABSTRACT:** Enter an abstract giving a brief and factual summary of the document indicative of the report, even though it may also appear elsewhere in the body of the technical report. If additional space is required, a continuation sheet shall be attached.

It is highly desirable that the abstract of classified reports be unclassified. Each paragraph of the abstract shall end with an indication of the military security classification of the information in the paragraph, represented as (TS), (S), (C), or (U).

There is no limitation on the length of the abstract. However, the suggested length is from 150 to 225 words.

14. **KEY WORDS:** Key words are technically meaningful terms or short phrases that characterize a report and may be used as index entries for cataloging the report. Key words must be selected so that no security classification is required. Identifiers, such as equipment model designation, trade name, military project code name, geographic location, may be used as key words but will be followed by an indication of technical context. The assignment of links, rules, and weights is optional.

UNCLASSIFIED

Security Classification