

FOREWORD

This report was prepared by National Research Corporation, Cambridge, Massachusetts, under Air Force Contract AF 33(657)-10394, Task No. 130903 of Project No. 1309, NRC Project No. 82-1-0142. The work was performed under the direction of the Air Force Flight Dynamics Laboratory, Research and Technology Division, with Wayne Yarcho and Vernon Mangold acting as project engineers.

This report covers work conducted from December 1962 to March 1964.

Contrails

ABSTRACT

This report is a detailed study of the principle high vacuum measuring instruments with a discussion of their applications and the many sources of error. A section is also included on the calibration of these measuring instruments.

This Technical Documentary Report has been reviewed and is approved.

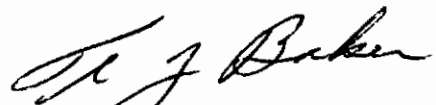

THERON J. BAKER
Asst. for Research & Technology
Vehicle Equipment Division
AF Flight Dynamics Laboratory

TABLE OF CONTENTS

	<u>Page</u>
I. INTRODUCTION	1
II. ORGANIZATION OF REFERENCES	3
III. VACUUM GAUGES GENERAL	4
A. General Discussion	4
B. Vacuum Errors	4
C. Electrical Errors	6
D. Human Errors	7
IV. LIQUID MANOMETERS	8
A. General	8
B. Barometric Manometer	10
C. U-Tube Manometer	19
D. Micrometer Manometer	19
E. Interferometer Liquid Manometer	20
F. McLeod Gauge	22
G. Tilt McLeod Gauge	32
V. MECHANICAL MANOMETERS	35
A. Air Lubricated Piston Gauge	35
B. Aneroid Manometer	37
C. Bourdon Gauge	39
D. Diaphragm Gauge	41

TABLE OF CONTENTS (Continued)

	<u>Page</u>
VI. MANOMETERS DEPENDING ON THE PHYSICAL PROPERTIES OF THE GAS	45
A. Molecular Gauge	45
B. Acoutical Gauge	48
VII. MANOMETERS DEPENDING ON THE THERMAL PROPERTIES OF THE GAS (THERMAL CONDUCTIVITY GAUGES)	52
A. General	52
B. Pirani Gauge	54
C. Thermocouple Gauge	57
D. Thermopile Gauge	59
E. Knudsen Gauge	61
VIII. MANOMETERS DEPENDING ON THE ELECTRICAL PROPERTIES OF THE GAS (ION GAUGES)	66
A. General	66
B. Schulz Phelps Gauge	72
C. Bayard-Alpert Ion Gauge	74
D. Nottingham Ion Gauge	74
E. Hot-Cathode Magnetron Gauge (Lafferty Gauge)	76
F. Alphasatron [®] Gauge	79
G. Penning (Phillips) Gauge	83
H. Cold-Cathode Magnetron Gauge (Redhead Gauge)	85

TABLE OF CONTENTS (Continued)

	<u>Page</u>
IX. VACUUM GAUGE CALIBRATION	89
A. Calibration in the Range Atmosphere to 10 Torr	89
B. Calibration in the Range 10 Torr to 10 ⁻⁵ Torr	91
C. Calibration Below 10 ⁻³ Torr	93
D. Recommended Calibration Method for 1 Torr to 10 ⁻⁹ Torr and Lower	100

LIST OF ILLUSTRATIONS

<u>Figure</u>		<u>Page</u>
1	A. U-Tube Manometer B. Barometric Manometer	18 18
2	Interferometric Oil Manometer	21
3	McLeod Gauge	23
4	Four Methods for Raising Mercury in McLeod Gauge	24
5	Tilt McLeod Gauge	34
6	Air Lubricated Piston Gauge	36
7	Bourdon Gauge	40
8	Diaphragm Gauge	43
9	Acoustical Gauge Sensor	51
10	Acoustical Gauge Circuit	51
11	Pirani Gauge	56
12	Thermocouple Calibration Curve	58
13	Thermopile Gauge	60
14	Knudsen Gauge	62
15	Schulz-Phelps High Pressure Ion Gauge	73
16	Bayard-Alpert Ion Gauge	75
17	Lafferty Hot Filament Magnetron Gauge	78
18	Schematic Sketch of the Alpatron Ionization Gauge	80
19	Relative Responses of Alpatron Gauge to Various Gases	80
20	Penning Gauge	84

LIST OF ILLUSTRATIONS (Continued)

<u>Figure</u>		<u>Page</u>
21	Redhead Inverted Magnetron Gauge	86
22	Calibration System Atmosphere to 10 Torr	90
23	Calibration System 10 Torr to 10^{-4} Torr	92
24	Orifice-Type Calibration System Using Flow Meter	96
25	Multiple Stage, Conductance Limited Pressure Reduction Calibration System	97
26	Calibration Curve	102
27	Calibration Curve	103

Contrails

I. INTRODUCTION

The field of high and ultrahigh vacuum has grown tremendously in the past few years. In earlier days the accurate measurement of the absolute pressure attained was not a prime requirement. With the advent of the scientific exploration of space much more precise data is necessary for an understanding of the physics of the earth's atmosphere and the space beyond. This has led to the present demand for better and more accurate instruments for the measurement of high vacuum. Unlike most areas of physics, vacuum measurements cover a range of 17 orders of magnitude and even this range is still expanding. Because of the fast growth and expanding range many instruments have been devised for measuring parts of the total range. This report is designed to help the buyer and user of such equipment in the selection and proper utilization of these instruments. All of the gauges of commercial importance are covered along with the gauges under development at the National Bureau of Standards. It is an indication of the speed of growth in this field that the Bureau is not prepared to certify any measurements or instruments below the first two orders of magnitude from atmospheric pressure.

Although there are many commercially available types of instruments, they fall into only four or five distinct classes. These classes are based on the physical principle which senses the pressures.

1. Force balance gauges in which the unknown pressure is balanced with a known or measurable force. These include a group which might be considered a subclass - gauges which depend on the elastic properties of materials.
2. Gauges which depend on the thermal properties of the gas.
3. Gauges which depend on the mechanical properties of the gas.
4. Gauges which depend on the electronic properties of the gas.

All of the commercial gauges generally available are discussed in the following sections.

Manuscript released by author April 1964 for publication as a RTD Technical Documentary Report.

Contrails

At the moment there are only four gauges which are considered as primary standards -- that is, the absolute pressure can be determined from the basic physical parameters of the gauge itself. These include the liquid manometers, the McLeod Gauge, the air lubricated piston gauge, and the Knudsen Gauge. All of these gauges are discussed in detail so that the user can obtain the best possible precision for accurate measurements in their range.

II. ORGANIZATION OF REFERENCES

In most cases the list of references appearing at the end of each section is not complete. Because these lists would be too long only the more basic and latest references have been listed. A complete bibliography on vacuum gauges can be found in NBS Monograph 35 "Bibliography and Index on Vacuum and Low Pressure Measurement."

III. VACUUM GAUGES GENERAL

A. GENERAL DISCUSSION

For many years the production and measurement of high vacuum has been more of an art than a science. Now that vacuum techniques have become widely used as a tool in scientific research, the need for precise measurement has become a necessity for the control of experiments and the simulation of space. This is also true for the more routine commercial processes using high vacuum.

The application of a vacuum gauge to a specific measurement problem requires a knowledge of the many possible errors if the measurement is to be meaningful. Indeed, in many cases the error can be several orders of magnitude. Because many of the errors apply to all types of vacuum gauges, these will be discussed in this section and the errors applicable only to a class or a specific type will be discussed under the appropriate sections.

B. VACUUM ERRORS

Basic to the proper use of any gauge designed to be used below atmospheric pressure is the understanding of outgassing and how it affects measurements at low pressure.

At atmospheric pressure and room temperature any solid surface is covered with gas molecules and other contaminants depending on past history (fingerprints, moisture, grease, oil, oxides, etc.). If the surface has been exposed to these conditions for some time, the gas on the surface is in equilibrium with the surrounding gas -- the same number of molecules hit and stick to the surface as the number that leave the surface and there is no net transfer of gas molecules.

A change in pressure will upset this condition and equilibrium will again be reached only after a net transfer of molecules to or from the surface. This may take some time depending on the gas molecule and the surface involved. The process is not only affected by the molecules on the surface but also those dissolved in the surface material. In the case of solids or liquids on the surface, if the pressure is reduced so that the boiling point is reached, large amounts of vapor will be released until the solid or liquid has boiled away. (Water boils at approximately 20 torr at room temperature.) If the pumping speed is low, it may take

Contrails

a very long time before the gas pressure is reduced below the vapor pressure of the solid or liquid on the surface.

The process of the cleaning up a surface in this manner can be speeded by increasing the temperature. At very low pressures it is necessary to bake out a system (and gauges) in order to reach the low pressure in a reasonable time. Because different parts of a system, including the gauge, may have entirely different surface contaminants, during the pump-down period different parts of the system can be at quite different pressures. This is particularly so if various parts of the system are connected with small pipes. It is for this reason that a gauge connected to a vacuum system through a small tubulation can read a pressure several orders of magnitude higher than the pressure in the system. If reliable measurements are to be made the gauge must be at equilibrium with the system. This requires large tubulation and a clean gauge.

Because an air leak in the gauge will not permit equilibrium conditions to exist, even small leaks in the gauge will negate the measurement. Outgassing or leaks in the tubulation will have the same effect. For this reason, rubber and most plastic materials should not be used in the gauge or its tubulation if reliable measurements are to be made. As a rule of thumb, if a gauge can be pumped down two orders of magnitude below the operating pressure, leaks and outgassing will probably introduce errors of only 1% or less.

With some gauges there is an opposite effect where the gauge acts as a pump. Short term pumping effects can be seen if the temperature of any internal surface is dropping rapidly. After outgassing a gauge by heating the internal structure, as the temperature falls, new equilibrium conditions require the ingestion of gas on the surface and the gas disappears just as if pumped away. This situation only exists until equilibrium is reached. The ion gauge, however, continuously pumps at a speed depending on the electron current, and on the species of the gas. If the tubulation to the gauge is small, this pumping can introduce measurement errors on static systems not only because the pressure in the gauge will be lower, but also because the selective pumping will change the composition of the gas and the composition change will affect the ion gauge reading.

As noted above, cleanliness of the gauge is a very important factor in accurate measurements. In some cases, special precautions

must be taken to protect the gauge from contamination in the vacuum system. On systems in which solid metals are evaporated, a simple optical baffle is sufficient. Oil and mercury vapors can be removed with a cold trap near the gauge. In this case, however, the gauge will measure only the partial pressure of the noncondensable gases.

At very low pressures the selection of the point on the system for the gauge port will affect the gauge reading. If the gauge port faces a cooled surface, the gauge reading will be low and if it faces a hot surface, the reading will be high. This is due to the high outgassing rates at elevated temperatures. Similar areas of high outgassing at normal temperatures such as gaskets or leaks will affect the gauge reading. For this reason, gauges which can be immersed directly in the environment to be measured (nude gauges) will give a better average pressure reading. The gas molecules arrive at the gauge from all directions and not from a small angle of view.

C. ELECTRICAL ERRORS

All gauges which depend on an electrical power supply or an electronic amplifier are subject to errors due to variations in these systems. Power supplies may or may not be stabilized. Aging of components may change the output voltages or amplifier gain. So many possible sources of error exist in a complete electronic system that the best approach is to check out the system on a periodic basis. Critical voltages and currents can be continuously monitored with meters. Good repeatability can be obtained as long as the same meters are used. However, the accuracy of the normal 2% moving coil meter should not be relied on. A gauge calibrated with one power supply and amplifier will not necessarily be accurate when used with another power supply and amplifier unless all of the voltages supplied to the gauge and the amplifier sensitivity are matched to the original control system.

Many gauges, which are good repeatable instruments, suffer from the poor readout equipment available with commercial gauge systems. The common 2% meter with decade switching equipment is not an ideal choice for good measurements. The manufacturer of the meter indicates the accuracy as + 2% of full scale. At 10% of full scale, this is + 20%. The repeatability of a given reading is generally better than this, so that if the meter is included as a part of the system when the gauge is calibrated, the

Contrails

electrical errors are washed out. However, random errors such as bearing friction, zero setting, reading errors, etc. are not washed out. These errors are errors of angle and therefore a percentage of full scale. A factor of three improvement can be obtained by doubling the number of ranges so that full scale readings of 3 and 10 are used. Only the top 2/3 of the scale are then used and the + 2% of full scale will be only + 6% at 1/3 scale. An even better arrangement is to use a digital voltmeter. With a good DVM, the linearity of the amplifier or gauge is the limiting readout error.

D. HUMAN ERRORS

Most operator errors are just plain mistakes - reading a number wrong - transposing numbers - knocking a knob on a control panel, etc. There are, however, some bias errors which show up between operators. Sometimes these can be removed by proper lighting or with mirror-backed scales to remove parallax. In vacuum gauges, these errors are small compared to the total system error, except possibly the primary standards. A good careful operator will record better precision than the sloppy workman but not necessarily more accurate. He must know how to use the instrument properly if the data is to be accurate.

IV. LIQUID MANOMETERS

A. GENERAL

The liquid manometer has for many years been the standard instrument for measuring low pressures. With newer techniques for measuring the difference in liquid level, the accuracy and range has been greatly improved. All of these instruments are true force per unit area measuring devices and therefore primary standards. The force is measured directly by measuring the height of a column of liquid, of known density, supported by the pressure to be measured. The accuracy is limited only by the precision of measurement of the physical parameters.

The original unit of pressure -- mm of Hg -- was taken directly from the height measurement of the mercury column in a mercury manometer, (1 mm of Hg = 1 torr). This assumed a constant value for the density of mercury and the force of gravity. For precise measurements these parameters must be corrected for standard conditions.

The height measurement itself is generally the parameter limiting the precision of the instrument. The various forms of manometer are different only in the method of determining the differences in levels of the two liquid surfaces. As this measurement improves, there are other errors which can no longer be neglected. Density and gravity have already been mentioned. These corrections for mercury are well known to a high order of precision. The temperature correction for density is also known. Temperature differences between the two arms of the manometer, however, cannot be corrected easily. For this reason an accurate manometer requires constant temperature conditions free from drafts and convection currents which could set up unequal temperatures in the two arms.

All manometers measure a difference in pressure between the two arms. The reference pressure on one arm can be atmospheric pressure but usually "zero" pressure reference is used. This is a pressure which is small compared to the minimum error required. For the barometric manometers a mechanical pump which will maintain a pressure of 10 microns is sufficient. This pressure should be monitored with a Pirani or thermocouple gauge. For the Micro-meter and Interferometer manometers the reference must be even lower -- at least a factor of ten below the minimum reading of the

Contrails

gauge. This will require diffusion pumping and an ion gauge to monitor the pressure.

If the fluid used in the manometer is different from the fluid used in the reference pumping system, some means such as a cold trap must be provided to prevent backstreaming of the pumping fluid into the manometer.

The requirements for the manometer fluid are quite critical. Although mercury is used in the majority of instruments, there are advantages to the use of lighter, less dense fluids. The fluid must have a low vapor pressure; it must be chemically inert; and should not dissolve the atmosphere to be measured. The density must be known, as well as the temperature coefficient of density. If the density is a function of pressure, the compressibility function must also be known. Mercury comes the closest to being an ideal fluid and does permit direct reading in terms of the pressure unit. However, a lighter fluid will give much higher sensitivity. This advantage -- a much larger height measurement for the same pressure -- would be very desirable for improved accuracy and lower minimum pressure reading. For this reason diffusion pump oils, which meet most of the criteria, have been used. The major problem, however, is that they will dissolve the gasses being measured. This increases the outgassing and ingassing problem and therefore requires long periods of time for the gauge to come to equilibrium with the atmosphere to be measured. In most cases this disadvantage outweighs the improvement in sensitivity.

In some instruments the capillary effects are not balanced by the use of matched capillaries, but are included as a correction in the calibration. If fluids other than mercury are used, the capillary effects must be accounted for.

Mercury is an industrial poison and should be handled with care. Ingestion and breathing of the vapors should be avoided. Spilled mercury should be cleaned up as soon as possible. Dusting spilled mercury with flowers of sulphur will aid in clean up by reducing the evaporation rate. A vapor density of .1 milligram per cubic meter of air is considered the maximum acceptable concentration in working areas.

As a safety measure mercury manometers should have a constriction in the connection between the two arms to prevent sudden pressure changes driving the mercury out of the gauge.

B. BAROMETRIC MANOMETER

1. Principle of Operation

The mercury manometer may take several forms. Basically it consists of a pool of mercury connected to a vertical piece of glass tubing long enough to support a barometric column of mercury. The pool is open to the atmosphere and the unknown pressure is connected to the vertical tube. A millimeter scale which can be moved up or down is mounted adjacent to the vertical tube. For each measurement the scale must be adjusted so that the lower zero end is at the level of the top surface of the mercury pool. In this configuration the column height is not a direct measurement of the unknown pressure but a difference from atmospheric pressure. This type is generally used for rough measurements between 10 torr and atmospheric pressure.

If the unknown pressure is applied over the mercury pool and a very low pressure (less than 10 microns) is maintained over the vertical tube, the instrument will then be direct reading. The tube can be sealed off, filled with mercury and then inverted into the pool of mercury. If care is taken so that no air is permitted to reach the closed end, this method is satisfactory for short term use, but with age the vacuum at the closed end deteriorates due to gases dissolved in the mercury. In order to maintain a good vacuum over the column a separate vacuum system is generally used to obtain long term stability.

The mercury manometer is a primary pressure standard, since it measures force per unit area directly. A properly constructed gauge will read pressures down to 10 torr with a precision of 1%. While lower pressures can be measured the reading errors increase quite rapidly. With more sophisticated techniques for measuring the mercury levels, and with compensation for temperature and gravity, 0.1% precision can be attained. Because it is a standard and easily made, the mercury manometer is very widely used.

2. Fundamental Errors

Theoretically the only errors associated with the manometer working against a high vacuum are those in measuring the force. These measurements are the difference in height of the two mercury surfaces, the density of mercury and the gravitational force. The errors associated with measuring these fundamental quantities

Contrails

can be reduced to very low values compared to the uncertainties which appear in the gauge itself.

The choice of height measuring instruments will depend almost entirely on the precision required. Sighting a millimeter scale by eye is adequate for measurements to ± 1 mm. A vernier and sighting ring will improve this to ± 0.1 mm. A good cathetometer will read to 0.01 mm. There are many techniques for making length measurements very accurately.

The density of pure mercury is known to a very high degree of accuracy. Its temperature coefficient and compressibility are also well known so that the true density can be determined to a very high order of accuracy under all conditions.

The gravitational force varies with latitude and altitude. However, the variation is well known and tables are available for the correction necessary at different latitudes. The variation is as much as 1/2% so that corrections must be made if high accuracy is required.

An additional error is associated with the manometer working against atmospheric pressure. Since the height measurement must be subtracted from atmospheric pressure the barometer reading must be known. For this reason the zero pressure reference method is generally used for accurate measurements.

3. Physical Errors

The major error introduced in constructing a gauge is the capillary forces acting on the mercury in the vertical tube. In small diameter tubes the capillary forces depress the mercury surface in the tube. This capillary depression must be accounted for in the measurement of h when small tubes are used. Unfortunately, the capillary depression is not always constant. It is affected by the purity of the mercury and the cleanliness of the glass. For this reason the tube is usually chosen with a large enough diameter so that the capillary depression is less than the precision desired. (See Table 3)

The determination of h must, of course, be in the direction of the force. The scale must therefore be on a plumb line. A bubble level is usually provided on the scale or cathetometer for this purpose. Vibration of the instrument may cause an error

Contracts

TABLE 1
RATIO OF THE DENSITY OF MERCURY AT t_0 TO THE DENSITY AT 0°C AT 1 ATM. OF PRESSURE

°C	0	1	2	3	4	5	6	7	8	9
0	1.00000000	0.99981859	0.99963722	0.99945591	0.99927465	0.99909344	0.99891229	0.99873118	0.99855012	0.99836911
10	0.99818816	.99800725	.99782639	.99764559	.99746483	.99728412	.99710346	.99692285	.99674228	.99656177
20	.99638130	.99620088	.99602051	.99584019	.99565991	.99547968	.99529950	.99511936	.99493927	.99475923
30	.99457923	.99439928	.99421938	.99403952	.99385970	.99367993	.99350021	.99332053	.99314089	.99296130
40	.99278175	.99260225	.99242279	.99224337	.99206400	.99188467	.99170538	.99152614	.99134694	.99116777
50	.99098866	.99080958	.99063054	.99045155	.99027260	.99009369	.98991482	.98973598	.98955719	.98937844

Contrails

TABLE 2

DENSITY OF MERCURY

Based upon the value of 13.5458 925 g/cm³ at 20°C and the ratios of Table 1

Temperature		Density	Temperature		Density
°C	°F	g/cm ³	°C	°F	g/cm ³
0	32.00	13.5950 889	30	86.00	13.5213 930
1	33.80	13.5926 226	31	87.80	13.5189 466
2	35.60	13.5901 569	32	89.60	13.5165 009
3	37.40	13.5876 919	33	91.40	13.5140 556
4	39.20	13.5852 277	34	93.20	13.5116 110
5	41.00	13.5827 641	35	95.00	13.5091 670
6	42.80	13.5803 014	36	96.80	13.5067 237
7	44.60	13.5778 392	37	98.60	13.5042 809
8	46.40	13.5753 777	38	100.40	13.5018 387
9	48.20	13.5729 168	39	102.20	13.4993 971
10	50.00	13.5704 568	40	104.00	13.4969 561
11	51.80	13.5679 973	41	105.80	13.4945 158
12	53.60	13.5655 385	42	107.60	13.4920 761
13	55.40	13.5630 805	43	109.40	13.4896 368
14	57.20	13.5606 230	44	111.20	13.4871 983
15	59.00	13.5581 663	45	113.00	13.4847 603
16	60.80	13.5557 102	46	114.80	13.4823 228
17	62.60	13.5532 548	47	116.60	13.4798 860
18	64.40	13.5507 999	48	118.40	13.4774 498
19	66.20	13.5483 459	49	120.20	13.4750 139
20	68.00	13.5458 924	50	122.00	13.4725 789
21	69.80	13.5434 395	51	123.80	13.4701 443
22	71.60	13.5409 874	52	125.60	13.4677 103
23	73.40	13.5385 359	53	127.40	13.4652 769
24	75.20	13.5360 850	54	129.20	13.4628 440
25	77.00	13.5336 347	55	131.00	13.4604 117
26	78.80	13.5311 852	56	132.80	13.4579 800
27	80.60	13.5287 362	57	134.60	13.4555 486
28	82.40	13.5262 878	58	136.40	13.4531 180
29	84.20	13.5238 402	59	138.20	13.4506 878

TABLE 3
CAPILLARY DEPRESSION OF MERCURY COLUMN
Millimeters of mercury at 20°C and under standard gravity

Bore of tube	Meniscus height in mm																			
	0.1	0.2	0.3	0.4	0.5	0.6	0.7	0.8	0.9	1.0	1.1	1.2	1.3	1.4	1.5	1.6	1.7	1.8	1.9	2.0
	Surface tension, 400 dynes/cm																			
8	0.054	0.108	0.162	0.214	0.265	0.315	0.363	0.409	0.453	0.494	0.533	0.569	0.603	0.633	0.660	0.684	0.705	0.723	0.737	0.749
10	.029	.058	.087	.115	.143	.170	.196	.222	.247	.270	.292	.314	.333	.352	.369	.384	.398	.410	.421	.430
16	.006	.011	.016	.022	.027	.032	.037	.042	.047	.052	.056	.060	.065	.068	.072	.076	.079	.082	.084	.086
22	.001	.002	.003	.004	.005	.006	.008	.009	.010	.010	.011	.012	.013	.014	.014	.015	.016	.016	.017	.018
	Surface tension, 450 dynes/cm																			
6	0.128	0.254	0.379	0.500	0.617	0.729	0.836	0.937	1.03	1.12	1.20	1.27	1.33	1.38	1.43	1.47	1.50	1.52	1.54	1.56
7	.088	.176	.263	.348	.430	.510	.587	.661	.730	.794	.855	.910	.961	1.01	1.05	1.08	1.11	1.14	1.16	1.18
8	.063	.126	.189	.250	.310	.368	.424	.478	.530	.579	.625	.668	.706	.744	.777	.807	.833	.855	.874	.890
9	.046	.093	.138	.183	.228	.271	.313	.353	.392	.429	.464	.498	.529	.557	.584	.607	.630	.649	.665	.679
10	.035	.069	.103	.137	.170	.202	.234	.264	.294	.322	.349	.375	.399	.422	.443	.462	.480	.495	.509	.522
11	.026	.052	.078	.104	.128	.153	.177	.200	.223	.245	.265	.285	.304	.322	.338	.354	.368	.380	.392	.402
12	.020	.040	.059	.079	.098	.117	.135	.153	.170	.187	.203	.218	.233	.247	.260	.272	.283	.293	.303	.311
13	.015	.030	.045	.060	.075	.089	.104	.117	.131	.144	.156	.168	.180	.190	.200	.210	.219	.227	.234	.241
14	.012	.023	.035	.046	.058	.069	.080	.090	.101	.111	.120	.130	.139	.147	.155	.163	.170	.176	.182	.187
15	.009	.018	.027	.036	.045	.053	.062	.070	.078	.086	.093	.101	.108	.114	.120	.126	.132	.137	.141	.146
16	.007	.014	.021	.028	.035	.041	.048	.054	.060	.067	.072	.078	.083	.089	.093	.098	.102	.106	.110	.113
17	.006	.011	.016	.022	.027	.032	.037	.042	.047	.052	.056	.061	.065	.069	.073	.076	.080	.083	.086	.088
18	.004	.008	.013	.017	.021	.025	.029	.033	.036	.040	.044	.047	.050	.054	.057	.059	.062	.064	.067	.069
19	.003	.006	.010	.013	.016	.019	.022	.026	.028	.031	.034	.037	.039	.042	.044	.046	.048	.050	.052	.054
20	.003	.005	.008	.010	.013	.015	.017	.020	.022	.024	.026	.029	.030	.032	.034	.036	.037	.039	.040	.042
21	.002	.004	.006	.008	.010	.012	.014	.015	.017	.019	.020	.022	.024	.025	.027	.028	.029	.030	.031	.032
22	.002	.003	.005	.006	.008	.009	.011	.012	.013	.015	.016	.017	.018	.020	.021	.022	.023	.024	.024	.025

Contrails

in determination of the exact level of the two mercury surfaces. This is particularly so where needle points are used to find the level in the mercury pool. The scale of the manometer will have errors due to imperfect ruling of the graduations and temperature variations in length. Reading a scale to better precision than its smallest graduation will not necessarily improve the precision of the instrument. The inherent errors in the scale must be better than the reading precision.

Temperature variations will also introduce errors due to the change in mercury density with temperature. For this reason the gauge should be used in a temperature controlled room or enclosure, free from drafts and correction currents. At least one manufacturer supplies an elastic scale which can be adjusted for ambient temperature and gravity corrections. This does not, however, compensate for differences in temperature at different parts of the gauge.

4. Human Errors

In all instruments there are errors associated with the operator. Reading errors or bias will be different for different operators. Where manipulation of some part of the apparatus is necessary other errors occur. With the mercury manometer these errors are in the determination of h . Either two scale readings from a common base point must be subtracted one from another or a zero point set to coincide with the lower level of mercury and then the h reading taken from the scale. In either case a double reading error is introduced. Some mercury manometers are equipped with various devices for determining or setting the zero more accurately than the top level reading. The level of the mercury pool can be read with a micrometer which positions a needle point to just touch the surface of the mercury. Another method provides a means for adjusting the level of the mercury pool to just touch a fixed needle point. A third method eliminates the need to set the zero each time a reading is made. The level of mercury in the pool falls as the mercury rises in the tube. This change in level is predictable if the diameter of the tube and cistern are known and constant, because the total volume of mercury is constant. The necessary correction is applied to the rulings on the scale - each graduation is shortened to compensate for the drop level in the cistern. This compensation requires that the instrument be filled with mercury to the zero mark on the scale when the pressure difference is zero. The error associated with

Contrails

this operation is a constant error or bias. All of these devices will help to reduce the reading error.

If a cathetometer or other more refined instrumentation is used for measuring h additional errors though small may also occur; the line of sight in an optical system may change with focus, the rotation of a telescope must be in a horizontal plane, the external instrumentation must be rigid with respect to the manometer, and many others depending on the system to be used.

5. Errors Associated With the Vacuum Environment

As with any vacuum gauge an air leak in the gauge or its tubulation will render it useless. The atmosphere in the gauge must be in equilibrium with the system to be measured. These problems are treated in the general section on errors.

Vacuum errors are also associated with the manometer types which work against a zero pressure reference. In the sealed-off tube the reference pressure is unknown and can contribute a large error. This can be checked within the precision of the instrument itself by comparing the atmospheric pressure reading with a good barometer. With the types of manometers which use a separate vacuum pump for the reference pressure, a gauge should be installed and the pressure maintained well below the minimum error required. In order to keep the mercury as clean as possible, some means such as a cold trap must be provided to prevent oil vapors from the vacuum system from contaminating the mercury. This also applies to the unknown pressure connection, if condensable vapors are present.

6. Determination of Errors

Some of the errors can be determined quite easily. Atmospheric pressure is a good high pressure check point if a good barometer is available. If a pressure less than 10 microns can be applied to the unknown pressure connection the zero point can be checked. These two check points will not separate the errors but will give a good over-all check of the gauge. Errors due to capillarity, reference pressure, leaks, outgassing, and usually reading errors, can be determined as a total error.

7. Minimizing Errors

Many of the techniques for minimizing errors have been pointed out in the discussion of the errors. The design should include a tube at least 3/4" I.D. and a mercury well at least 10 times the diameter of the tube. The glassware and mercury must be clean. The method for determining h will depend on the accuracy required of the instrument. Accuracy to 0.1 mm will require a sighting ring and vernier or cathetometer, and a precise method for determining or setting the zero level of the mercury pool. The temperature of the instrument must be constant and corrections made if the temperature is not controlled.

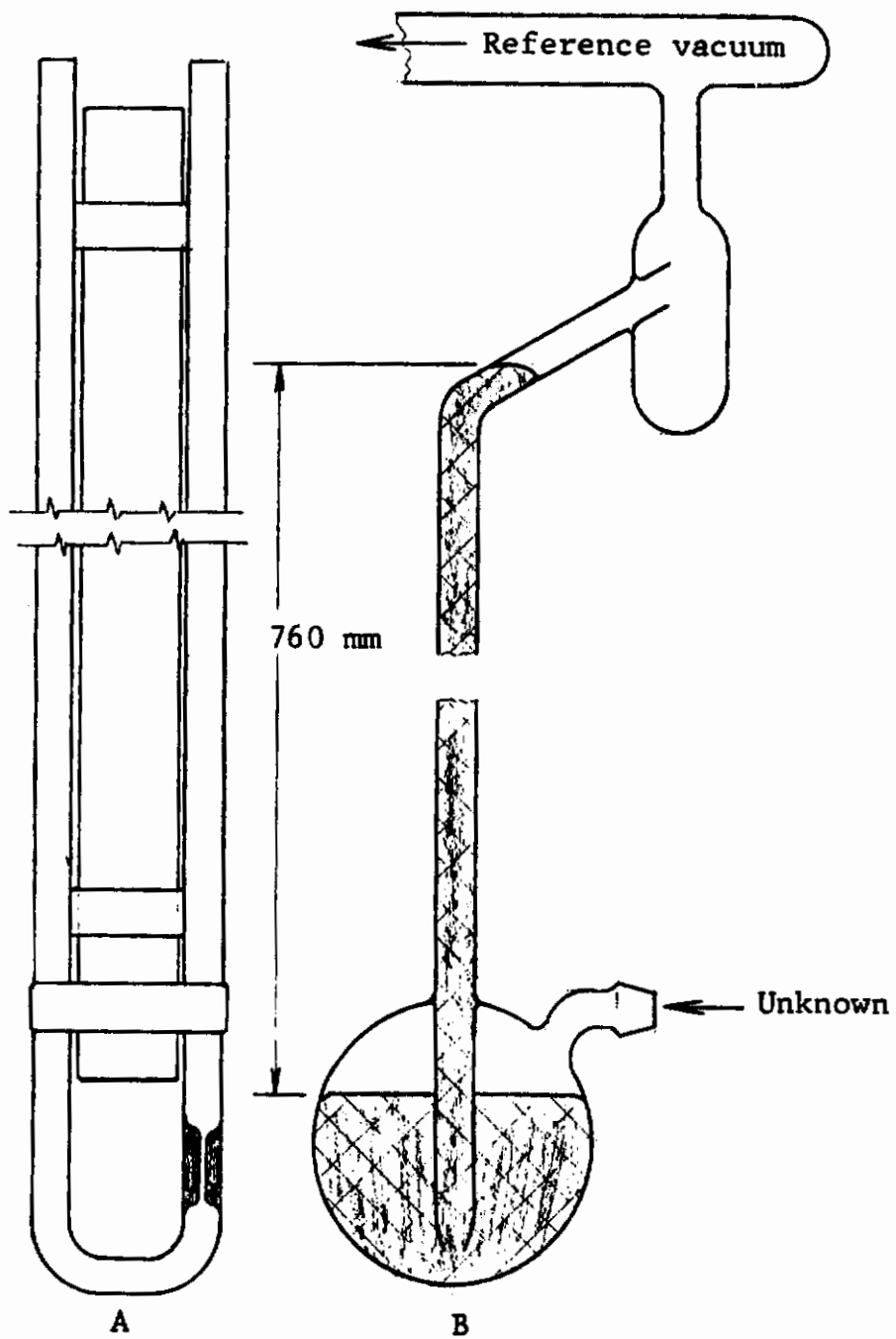

FIG. 1 A. U-TUBE MANOMETER
B. BAROMETRIC MANOMETER

C. U-TUBE MANOMETER

1. Principle of Operation

The U-tube is a special type of manometer. It consists of a small bore glass tube shaped in the form of a U with the arms usually longer than a barometric column (760 mm). The tube is half filled with mercury and a scale is attached between the two tubes. As with the mercury manometer the gauge can be operated with atmosphere as a reference, with one arm open to the atmosphere; or with a low pressure as reference, with one end sealed or pumped. The unknown pressure is connected to the opposite arm. The difference in height of the two mercury columns is the difference in pressure from the reference.

Because it is only a special type of manometer all of the discussion under the mercury manometer applies to the U-tube manometer. The one additional problem is the capillary forces on the mercury. With the small bore tubing the capillary forces depress the mercury levels. In order to equalize the capillary depression the two arms must be made with tubing of the same bore size and the diameter must be the same along the length of tubing. The clean glass and clean mercury requirement is even more critical, in this case, if the capillary depressions are to remain equal at all levels.

D. MICROMETER MANOMETER

1. Principle of Operation

The micrometer manometer is a special type of manometer used for measuring low pressures. Two mercury pools are connected below the mercury level with a small tube. One pool is exposed to the unknown pressure and the other is exposed to a very low pressure. The levels of the two pools are determined by means of a micrometer barrel operating a glass needle point. These are adjusted so that the needle point is just touching the surface of the mercury. The difference in levels is the pressure reading. This method can give a precision of $\pm .01$ mm or 10 microns with a well-built instrument and well-trained operator. In general, the instrument is not constructed to read a pressure greater than 20-30 torr. The minimum reading is approximately .01 mm but at this pressure the precision is $\pm 100\%$. One torr can be determined to $\pm .01$ mm or 1%.

Contrails

With two large pools, 7" to 10" in diameter, there are no capillary problems but the foundation for the instrument must be very stable. No motion of the mercury surface can be permitted if the needle points are to be adjusted properly.

Most of the errors discussed under Barometric Manometer apply to the Micrometer Manometer.

2. References

Hirsch, E. H., J.S.I. 36, 477 (1959).

Anon. U. S. National Bureau of Standards Technical News Bulletin 43, 71 (1959), "Manometer for Calibrating High-Altitude Pressure Devices."

E. INTERFEROMETER LIQUID MANOMETER

1. Principle of Operation

The interferometer manometer is a U-tube manometer in which the difference in level of the two liquid surfaces is measured by interferometry. It is an extension of the micrometric manometers. A manometer of this type using diffusion pump oil is now being developed by the National Bureau of Standards as a primary low pressure standard. This gauge is limited to pressures in the micron region down to 10^{-6} torr. A diagram of one model constructed at the Bureau is shown in Figure 2. The fringes observed are produced by interference between the reflections from the bottom of the optical flat and the surface of the oil. Differences in level of the two pools of oil as small as 0.1 fringe of non-chromatic light (mercury green line at 5461A) can be estimated. This is equivalent to 1.8×10^{-6} torr.

Because the measurement sensitivity is so high, errors, which in the normal U-tube are negligible, become the major errors. Instrument level is very critical, so that constant monitoring of the level is necessary. A difference in temperature of 0.1°C between the two legs will result in an error of approximately 2.6×10^{-5} torr. Vibrations which ripple the oil surface as much as one fringe destroy the usefulness of the interferometric technique. Because of these problems, and although they can be overcome, this gauge is an item only for the standards laboratory.

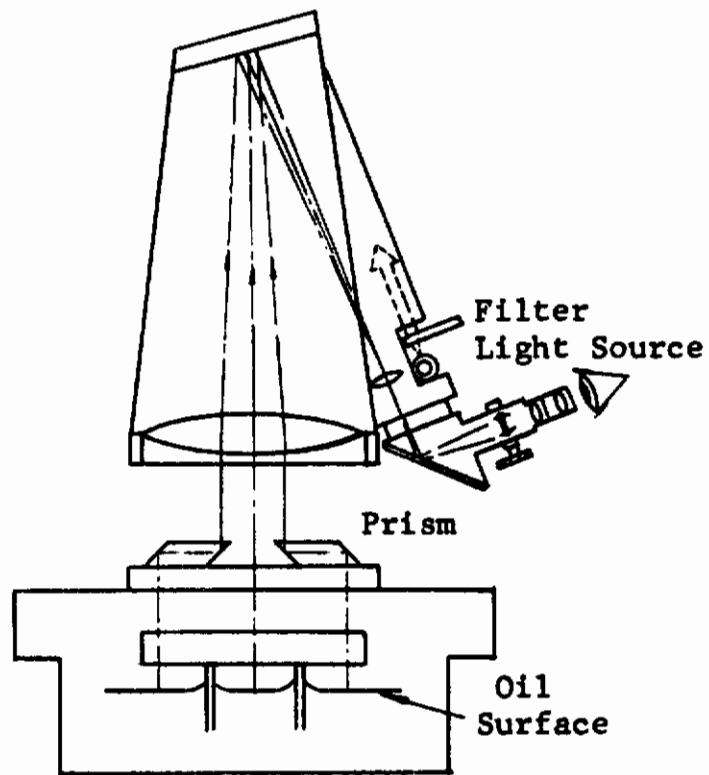
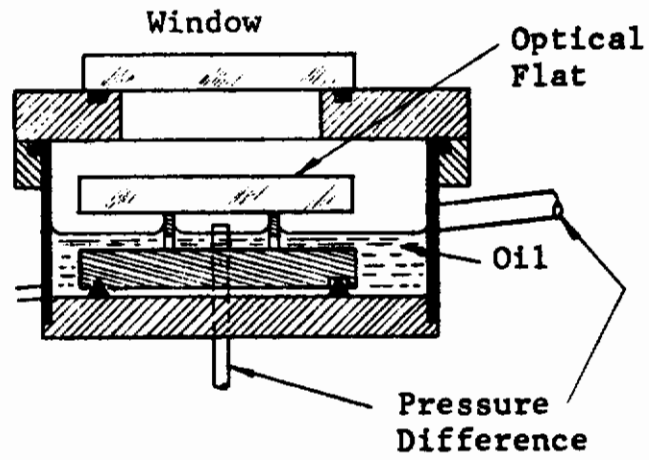

FIG. 2 INTERFEROMETRIC OIL MANOMETER

2. References

Manley, J. J., Proc. Phys. Soc. (London) 40, 57 (1927).

Jerview, Jean, Revue d'Optique 38, 29 (1959).

Thomas, A. M., D. P. Johnson and J. W. Little, 1963 Vacuum Symposium Trans. 468, (1963).

F. McLEOD GAUGE

1. Principle of Operation

The McLeod gauge is designed to read pressures below the range of the standard mercury manometers (barometric and U-tube). Basically it compresses a known volume of gas to a much smaller volume and then measures the pressure with a mercury column. By Boyle's Law $PV = P'V'$. If the compression ratio is known and the temperature remains the same, the unknown pressure can be computed.

The usual configuration of a McLeod gauge is shown in Figs. 3 and 4. The primary elements are the glass bulb and the two capillaries. The lower opening of the gauge is connected to a pool of mercury and the upper end of the side arm is connected to the unknown pressure. To measure the pressure the mercury is raised (by various means) from the pool. As the mercury height increases, it closes off the volume V at point a . As the mercury continues to flow it compresses the gas in the volume into the capillary at the top. The mercury will also rise in the side arm and side arm capillary. If the mercury in the side arm capillary is brought to rest so that it is level with the top of the bulb capillary, the new pressure h in mm and the new volume is $h \times$ cross sectional area of the capillary.

By Boyle's Law

$$p V_0 = (p + h) Ah$$

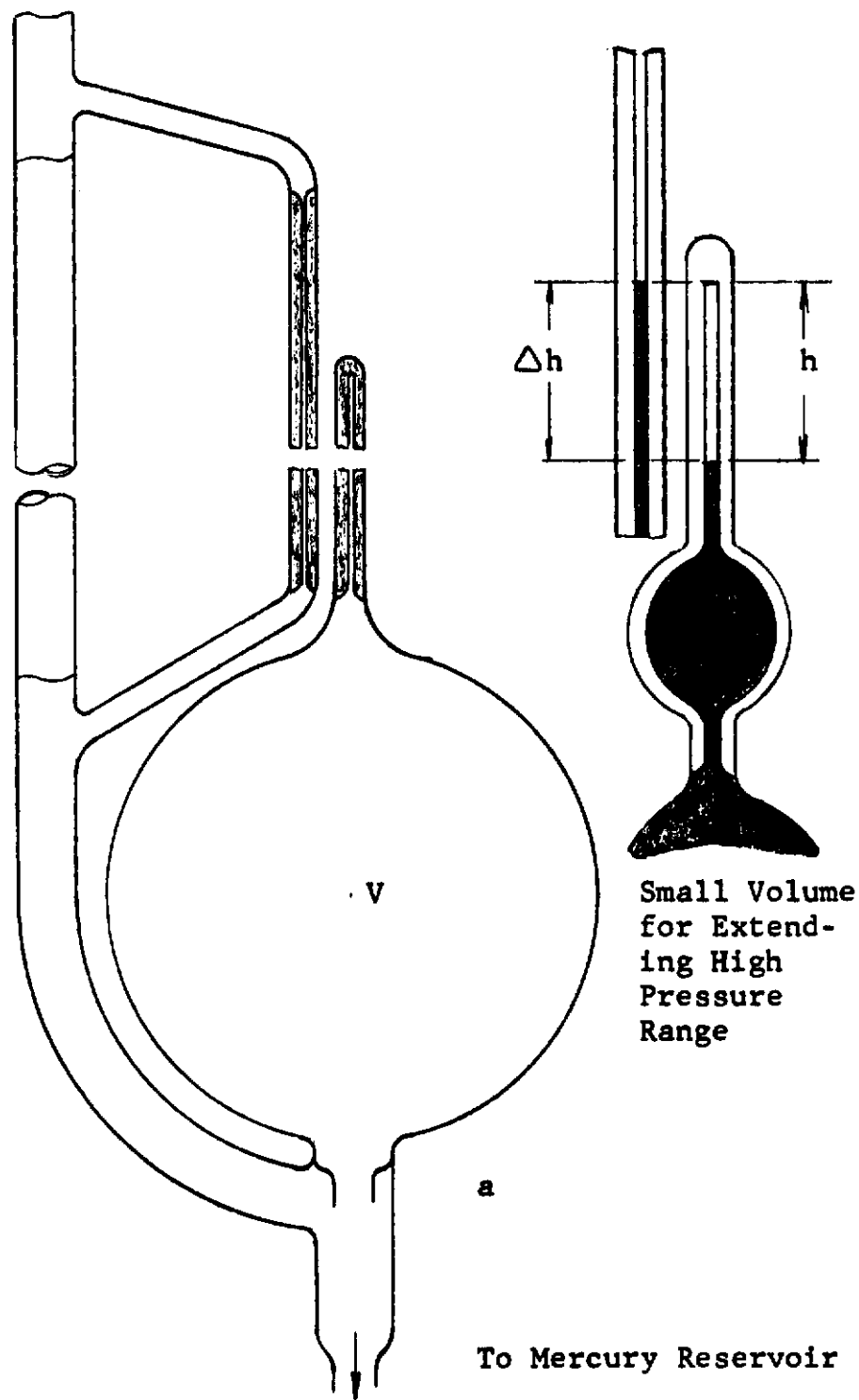

FIG. 3 McLEOD GAUGE

Contrails

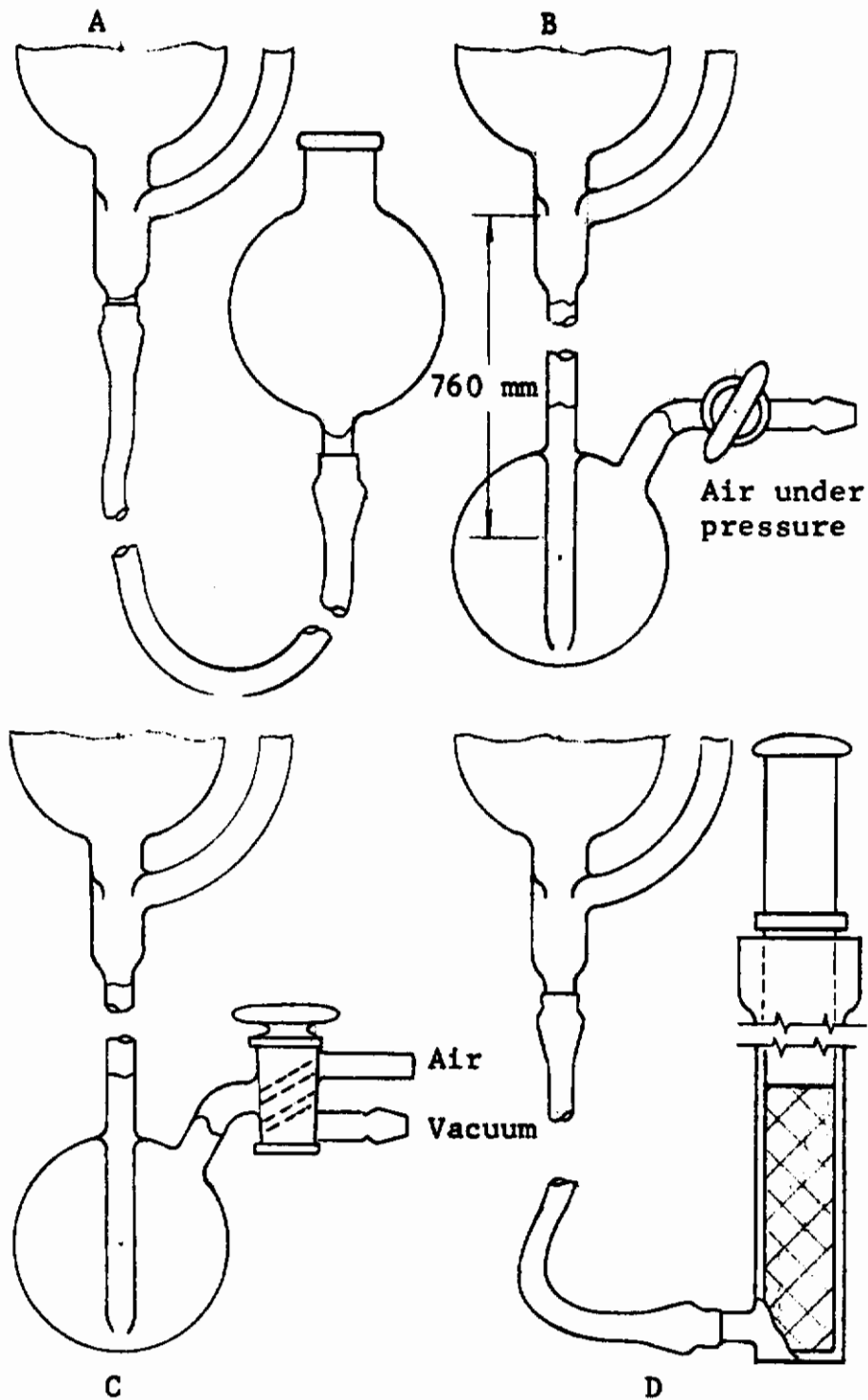

FIG. 4 FOUR METHODS FOR RAISING MERCURY IN McLEOD GAUGE
A. RESERVOIR IS LIFTED
B. GAS UNDER PRESSURE FORCE MERCURY INTO GAUGE
C. VACUUM OVER RESERVOIR, AIR DRIVES MERCURY INTO GAUGE
D. PISTON OVER RESERVOIR DISPLACES MERCURY INTO GAUGE

Contrails

where

p is the unknown pressure

V_0 is the bulb volume

$(p + h)$ is the new pressure (p is still present over the mercury in the open capillary, so the total pressure is p plus the mercury height)

A is the cross sectional area of the capillary

then

since the final volume Ah is much less than V_0 , it may be neglected in the $V_0 - Ah$ term and

$$p = \frac{A}{V_0} h^2$$

Since A and V_0 are constants for any one gauge, $\frac{A}{V_0}$ is calculated once and $p = kh^2$.

A scale calibrated from this equation is generally supplied with a commercial gauge.

An alternate method for reading the gauge is to use a fixed point on the closed capillary. If the mercury is brought to this point each time the new volume is a constant and the scale becomes a linear function of the height of the column in the open capillary. If a small volume is included at the base of the closed capillary (see Figure 2) the high pressure end of the range of the gauge can be extended.

The two capillaries must have the same bore diameter in order that the capillary forces on both mercury columns be equal.

There are a number of methods used to raise the mercury. A flask of mercury can be connected by means of a rubber hose to the lower end of the gauge and the flask then raised so that the mercury flows into the gauge. Some gauges are made with a permanent reservoir at the bottom. With a three-way stop cock and a separate vacuum pump, the mercury can be lowered by

pumping the air from above the mercury pool or raised in the column by admitting air over the pool. Another method uses a plunger to displace the mercury in the reservoir, thus forcing it into the gauge (see Figure 4).

The range of a McLeod gauge is limited by a number of factors (discussed below). In general, the accuracy falls quite rapidly below 10^{-3} torr although some gauges can read down to 10^{-7} torr. If high accuracy is required even at 10^{-3} torr all errors must be reduced to a minimum. McLeod gauges can be used for high pressures but they are not generally used above 10-20 torr since the U-tube or barometric column can be used more easily.

In theory, the McLeod Gauge is a primary standard. It depends only on the dimensions of the capillaries, the cut-off volume, and the force of gravity. In practice, however, its many sources of error can drastically limit its usefulness. Using extreme care in the design, construction and operation, Rosenberg has attained a precision of $\pm 0.5\%$ at 10^{-3} , $\pm 2\%$ at 10^{-4} , and $\pm 6\%$ at 10^{-5} torr. This represents the best results attainable. Most gauges will fall far short of these values. For this reason, and because it is a sampling device (not continuous reading) other gauges are generally preferred outside of the standards laboratory.

2. Fundamental Errors

Because the gauge depends only on the dimensions, the density of mercury, and gravity, errors in these quantities are the only fundamental errors. The diameter of the capillary and the volume can be easily measured to four significant figures and the density of pure mercury and the necessary corrections are known to a very high precision. Because all of these measurements can be so accurate, the errors in these quantities contribute little to the total error. It must be pointed out, however, that the mercury must be pure.

3. Physical Errors

There are a number of assumptions implicit in the theory of the McLeod gauge. Two capillaries having the same bore diameter do not necessarily produce the same capillary depression. Particularly as the diameter becomes smaller there can

Contrails

be wide variations in the depression. Even when the bores are thoroughly cleaned, and very pure clean mercury is used, capillaries less than 1 mm in diameter exhibit wide variations in capillary depression along the length of the bore. Rosenberg and Klemperer have shown that this can be reduced by a large factor if the bore is roughened by grinding the inside surface. Haase has obtained similar results by treating with hydrofluoric acid. This treatment will not correct for variations in the diameter of the bore. Modern Tru-Bore capillary tubing is generally better than 2% in sizes of 1 mm and larger. For smaller sizes the tubing should be selected by actual measurement if high accuracy is required. The two capillaries of course contribute two separate errors. One of these errors can be eliminated by using the mercury level in the large open column as the reference and correcting for the capillary depression in the closed column. If the gauge is pumped down well below its minimum readability the capillary depression can be measured at a number of points along the capillary. The average value can then be used. As a further refinement if the variations are repeatable the true value of depression may be used at any point of the capillary.

Another technique for equalizing the capillary forces is to tap the gauge after the columns have come to rest. Tapping will take the mercury rise in the columns. The menisci will then return slowly to a stable position. Readings should be made only after waiting several minutes for the columns to stabilize.

The formation of the closure of the closed capillary can be a source of error unless Clark's method is used to determine the true top of the capillary. In most cases the visible top is not the true zero point because the end of the bore is not flat. The calculations assume a constant cross section to the very end. In practice the glass blowing operation leaves the end round. Clark has shown that the true zero point can be found experimentally. A reference point is chosen, such as the external top of the closed capillary. At a pressure which would normally have an h of several mm, the mercury is raised in the gauge. Measurements of h and Δh are made for a number of points with the approaching zero (let the mercury in the open capillary go beyond the normal zero). If h is plotted versus $\frac{1}{\Delta h}$

Contrails

the line through the points will intersect the h axis at a value of h which is the difference between the reference and the true zero. This should be done for at least three different pressures to make sure the three plots cross the h axis at the same point.

This true zero is the point at which a square topped capillary would end if it had the same volume as the round end capillary. Similarly the round meniscus is also corrected as a part of this volume. As the same point on the meniscus is always used for the point of measurement reading, the gauge can introduce a large error particularly when h is small. The mercury in the open capillary cannot be positioned exactly on the zero line very easily. If the variation is ± 0.5 mm and h is 5 mm the error is $\pm 10\%$. If the error in reading the closed capillary is ± 0.5 mm, this is another $\pm 10\%$ and if the variation in capillary depression is ± 0.5 mm, another 10%. These three errors are directly proportional to h . For this reason the accuracy is always much better when h is large. The error in reading h can be reduced by using a cathetometer to read the mercury column in the closed capillary. The zero line error of the open capillary can also be reduced. Going back to the formula

$$p V_o = (p + h) Ah$$

We can see that the pressure term $(p + h)$ assumes h as the difference in column heights. If this difference is actually measured, the actual position of the column in the open capillary will be of no consequence

$$p V_o = (p + \Delta h) Ah$$

which reduces to

$$p = kh \Delta h$$

where h is measured from the zero point of the closed capillary to the mercury level in that capillary and Δh is the difference in levels of the mercury in the two

capillaries.

The cathetometer also has errors associated with its use. In general, these are small compared to the errors when reading with the unaided eye. The scale must be vertical. For this purpose most cathetometers are supplied with a bubble level set in the base. The horizontal cross hair must be level if the vertical cross hair is not used for centering the meniscus. It is also best to have both capillaries at the same focal point in order to eliminate any errors connected with changing focus. If it is necessary to move the telescope horizontally to read both mercury columns, the telescope must be level and the bearing must run true.

The density of mercury changes with temperature. Although normal changes in room temperature introduce a negligible error, if the mercury temperature changes when transferred from the reservoir to the bulb, the reading will drift during this change. Both reservoir and bulb should be maintained at the same temperature.

When a McLeod gauge is initially filled with mercury, it should be kept at a low pressure for some time to remove dissolved gases from the mercury. It is also helpful to transfer the mercury between reservoir and bulb a number of times during this period. Even after pumping for some time, small bubbles can be seen forming in the mercury as it is transferred. For this reason a gas trap is included in many gauges (see Figure 4). Since there is a problem only if the gas bubbles rise inside of the closed volume, the trouble can be eliminated by moving the mercury entrance to the gauge to a point under the side arm instead of under the bulb.

4. Errors Due to Vacuum Environment

One source of error which is peculiar to the McLeod gauge could also be included as a fundamental error. Boyle's law applies only to perfect or non-condensable gases. If any of the component gases in the atmosphere to be measured condense when compressed in the gauge, an erroneous reading will result. For this reason the gauge is usually connected to the system through a liquid nitrogen cold trap. The cold trap will also act as a pump on the system. If the pressure in the system includes a large proportion of partial

Contrails

pressures of condensables, the pressure in the system will drop. However, the McLeod gauge will then read the pressure of the remaining non-condensables correctly. The use of a cold trap will also prevent the mercury vapor from diffusing into the vacuum system. There is also an unresolved question as to whether, with a cold trap the gauge will read correctly. This is due to the transpiration of the mercury in the reservoir to the cold trap. This flow of vapor could by collision impart motion to other gas molecules away from the bulb, something like a diffusion pump. Ishii and Nakayana have observed temperature effects which they attribute to this mechanism. Menke and Reich have also measured this effect and have shown that it can be reduced if the tubulation from the reservoir to the gauge is made small so that the total flow of vapor is small.

As with most vacuum gauges, accurate measurements can only be made when the atmosphere in the gauge is in equilibrium with the atmosphere in the system to be measured. If gas is being adsorbed or desorbed from the walls of the gauge, the readings will not represent the true system pressure. After every change in system pressure the gauge must be given time to come to equilibrium with the system.

5. Stability

The stability of a well-designed and constructed McLeod gauge is very good. The major influences on stability are clean gauge and mercury, and temperature. The long term stability depends on the techniques used to maintain the internal parts and the mercury clean (assuming constant temperature). Large variations in capillary depression indicate the gauge should be cleaned and filled with new mercury. This will generally return the gauge to its original performance.

6. Minimization of Errors

Many of the techniques for minimizing errors have been indicated in the discussions above. In the design of the gauge itself the selection of gauge constants is a compromise. In general the capillary diameter should be large to minimize the vagaries of capillary depression. h should also be large in order to reduce the errors in measurement. However, both of these dimensions affect the compression ratio and therefore the minimum pressure measurable. For a

Contrails

given minimum pressure to be measured, d and h should be chosen so that the errors in capillary variation and the measurement of h are equal. The volume V is limited by structural strength and mercury cost. 2000 cc is generally considered the maximum. Smaller values may be used for higher pressures.

7. References on McLeod Gauge (Not Included in NBS Monograph 35)

C. Meinke and G. Reich: Vakuum Technik 12 79 (1963).
"How to Avoid Erroneous Readings with a McLeod Gauge Backed by a Cold Trap."

C. Meinke and G. Reich: Vakuum-Technik 11, 86-88 (1962).
"Comparison and Testing of Calibration Methods for Ionization Manometers." (In German.)

H. Ishii and K. Nakayama: Transactions of the Eighth National Vacuum Symposium, Vol. 1, pp. 519-524, Pergamon Press, Oxford 1962. "A Serious Error Caused by Mercury Vapour Stream in the Measurement with a McLeod Gauge in the Cold Trap System."

E. O. Löcherbach and F. J. Schittko: Vakuum-Technik 11, 51-57 (1962) "Calibration Measurements with a McLeod Manometer." (In German.)

M. Goto: Advances in Vacuum Science and Technology, Vol. 1, 266-270, Pergamon Press, Oxford 1960. "The Standard McLeod Gauge and the Calibration of Ionization Gauges Against It."

W. B. Nottingham and F. L. Torney: Transactions of Seventh National Vacuum Symposium, pp. 117-122, Pergamon Press, Oxford 1961. "A Detailed Examination of the Principles of Ion Gauge Calibration."

H. Ebert: Advances in Vacuum Science and Technology, Vol. 1, pp. 260-262, Pergamon Press, Oxford 1960. "On Vacuum Measurement with the McLeod Gauge." (In German.)

W. S. Kreisman: Transactions of the Seventh National Vacuum Symposium, pp. 75-79, Pergamon Press, Oxford 1961. "A High Vacuum Gauge Calibration System."

Contrails

G. W. Monk, W. W. Stickney and A. T. Calio: Transactions of the Eighth National Vacuum Symposium, pp. 531-533, Pergamon Press, Oxford 1962. "An Ultrahigh Vacuum Gage Calibration System."

S. Naiditch, Report on Physical Electronics Conference MIT 1953. "The McLeod Gauge as a Primary Standard."

J. Bannon R.S.I. 14, 6 (1943). "An Accurate High Sensitivity Oil McLeod Gauge."

J. C. Simons and J. R. Roehrig, Final Report NASA Contract NAS5-14 (1961). "Development of Calibration Equipment and Reference Standards for Measurements at Very Low Gas Densities."

W. B. Nottingham and B. L. Blackford, Report on Physical Electronics Conference MIT 1962 "Capillarity."

Blaha Slaboprondy Obzor 24 pp. 474 (1963). (In Czech.)

A. T. J. Hayward, JSI 39 367 (1962). "The Use of the McLeod Gauge with Gas Vapour Mixture."

D. J. Pacey, JSI 40 409 (1963). "A Wide Pressure Range McLeod Gauge."

F. L. Torney, Le Vide 17 580 (1962). "On the Calibration of Hot Filament Ionization Gauges."

G. TILT McLEOD GAUGE

1. Principle of Operation

The Tilt McLeod gauge is a special type of McLeod gauge designed to reduce the problems of the mercury life. It is a compact, small compression ratio gauge for use as a process instrument in the range of 10 microns to 10 torr.

As shown (see Figure 5) in the horizontal position the bulb and capillaries are open to the unknown pressure and the mercury is in the reservoir. When turned 90° the mercury flows by gravity to cut off the compression volume and fills the reference capillary to the top level of the closed

Contrails

capillary. Some adjustment of the angle is necessary to bring the reference capillary mercury column to the proper level. The vacuum connection is made either through a flexible rubber hose or a vacuum-tight swivel joint at the axis of rotation. Some designs will give an indication to lower pressures but the accuracy is very poor. A direct reading scale is usually supplied.

The Tilt McLeod gauge is a useful gauge for process work where high accuracy is not required. In recent years it has generally been replaced by the Pirani or Thermocouple gauge. The main disadvantages are that it is not a continuous reading instrument, and the necessity for a cold trap, if contamination of the gauge or process is to be prevented.

The discussion of errors under McLeod gauges applies to the Tilt McLeod. One additional problem is the vacuum connection. Vacuum leaks and outgassing of the rubber hose can easily destroy its usefulness.

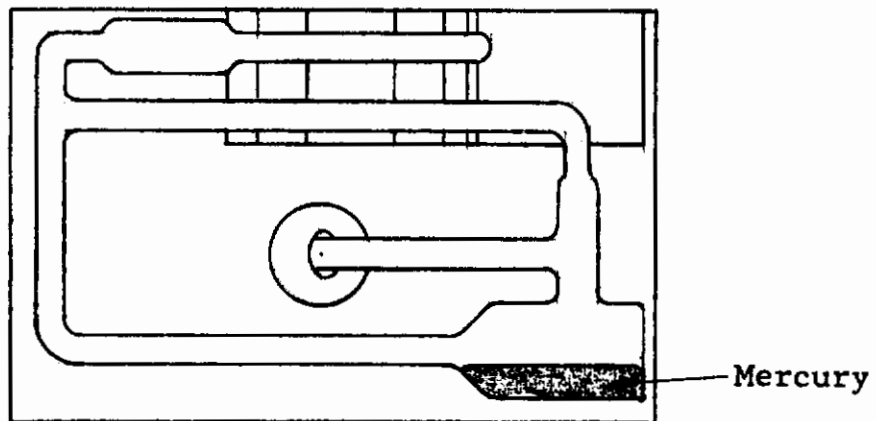

Gauge Open to System

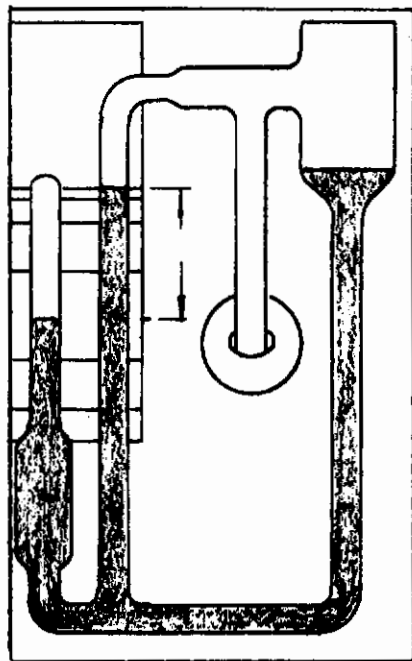

Turned 90°
for Measurement

FIG. 5 TILT McLEOD GAUGE

V. MECHANICAL MANOMETERS

A. AIR LUBRICATED PISTON GAUGE

1. Principle of Operation

This piston gauge is another of the gauges under development at the Bureau of Standards. The gauge consists of a glass cylinder and piston which have been lapped to provide a very close running fit. The cylinder is mounted on a stationary bearing formed by a second fixed piston at one end of the cylinder. The movable piston is eccentrically loaded with a small lead weight. The cylinder is rotated by a small electric motor. The difference in pressure on either side of the piston is measured by tilting the device so that the weight of the piston just balances the difference in pressure. The force on the measured cross-sectional area of the piston can be determined from the weight of the piston and the angle of elevation. The angle of elevation is determined from a height measurement with gauge blocks and a micrometer, and the hypotenuse is a fixed measurement along the axis of the gauge. The precision of measurement of all of these quantities can be as high as 1 part in 100,000 so that, if the other errors are small, a very precise measurement of pressure can be made. The gauge is of course a primary standard since it measures the force per unit area directly. The pressure range is about 1 torr to atmospheric pressure and the attained accuracy varies between 1 part in 10^4 to 1 part in 10^5 between 10 torr and the atmosphere.

2. The Errors Which Affect the Piston Gauge

Because this gauge is not commercially available and because the only reported work has been done by the Bureau of Standards, a discussion of the errors will not be included here, but reference is made to the Journal of Research of the N.B.S., Vol. 63C, July-Sept. 1959, in which there is a paper by V. O. Hutton. This paper gives a thorough discussion of the errors and the experience obtained on two air lubricated piston gauges at the Bureau.

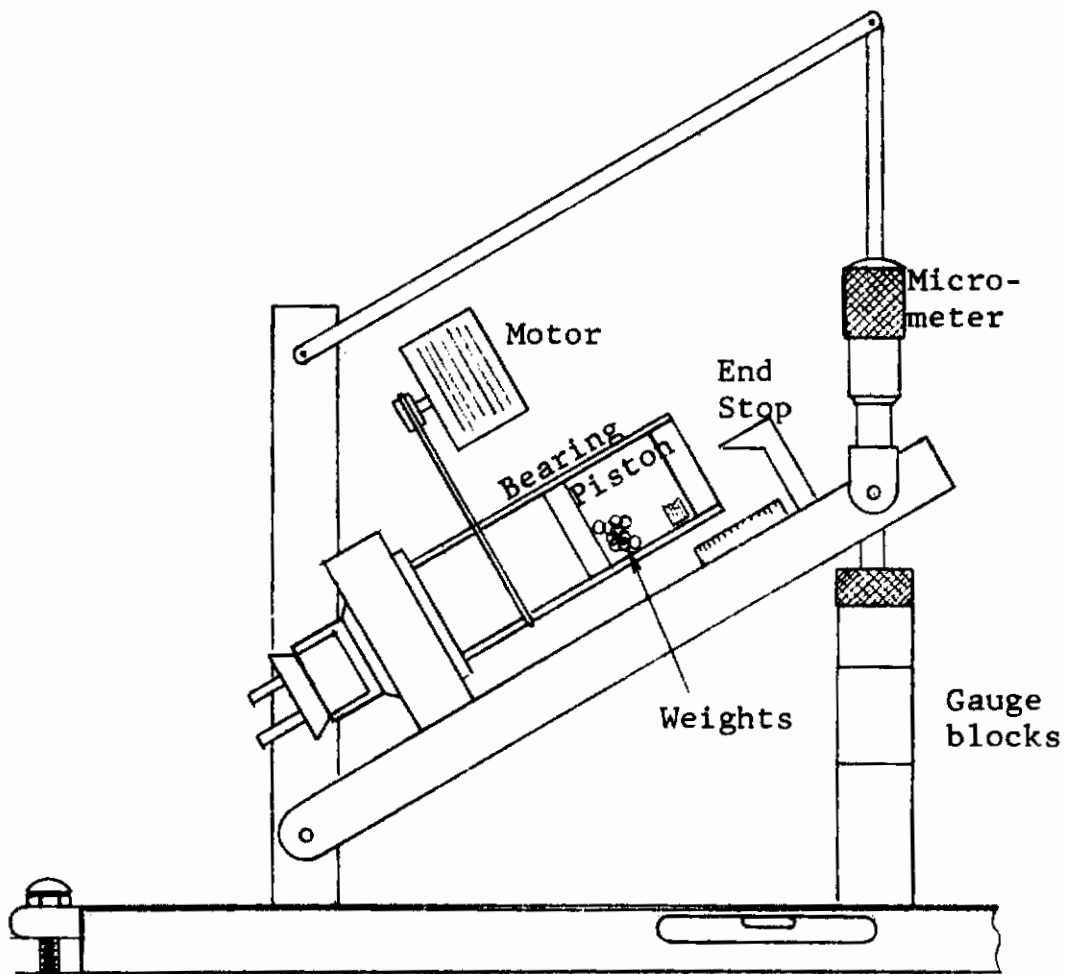

FIG. 6 AIR LUBRICATED PISTON GAUGE

B. ANEROID MANOMETER

1. Principle of Operation

The Aneroid manometer measures pressures by indicating the deflection of a diaphragm or bellows. Usually the basic element is a small evacuated and sealed cell which is exposed to the unknown pressure externally. The external pressure flexes the walls of the cell. The deflection is amplified mechanically with lever arms which move a pointer on a dial. An Aneroid barometer is a well known instrument of this type.

Although it is a true pressure measuring instrument, calculation of the forces acting on the diaphragm is not easily accomplished. Each instrument is generally calibrated against a mercury manometer. However, the aneroid manometer has many advantages which make it a good secondary standard. With temperature compensation the accuracy is .1%. It is a rugged instrument and not sensitive to the composition of the gas to be measured. It will indicate pressures down to approximately .1 torr, although the accuracy is very poor below approximately 10 mm. Without temperature compensation, the accuracy is about 1%.

The Aneroid manometer is a very good general-purpose instrument for its pressure range. It is rugged and has a long maintenance-free life. Aside from the possibility of corrosion in the gauge, it needs no protection from the atmosphere to be measured and it will not contaminate that atmosphere.

2. Fundamental Errors

The stability of the elastic constant of the diaphragm or bellows is the major fundamental error. Generally the aneroid cell is aged before calibration in order to stabilize the aging effects. Temperature compensation is necessary for high accuracy.

3. Physical Errors

Along with stability problems, aging and temperature of the cell is the hysteresis of the diaphragm. Although the hysteresis effects of the diaphragm can be made small compared

Contrails

to other errors by careful design and manufacture, the additional loading of the mechanical magnifying systems is very critical. The use of jeweled bearings for the pivots is usually necessary to reduce the frictional loading and maintain a small hysteresis error for long periods of time. As the oil in the bearings ages and the friction increases, the error may become a major error.

Hysteresis errors are generally improved by tapping the gauge after the pressure has changed. This helps overcome static frictional forces thereby reducing the hysteresis.

Temperature effects are primarily from the cell itself. Design and choice of materials can reduce the temperature errors and compensation with a second cell can reduce the error by a factor of ten. A typical instrument without compensation will have a temperature effect of .4% of indicated reading for a 10°C change.

The errors associated with the motion magnifying linkage are primarily backlash and changes in friction. The backlash is usually eliminated by means of spring loading the system. This of course loads the diaphragm of the cell so that changes in the spring tension may cause zero shift or calibration change or both. Errors due to friction in the bearings are usually small with good design and choice of bearings. In some instruments the mechanical system is immersed in the vacuum environment. In this case oil is not a good lubricant. It not only will dry out, but in the process cause outgassing problems. If an inexperienced person tries to repair the gauge and oils the pivots, frictional errors may increase many times.

Use of the instrument with corrosive atmospheres will change the elasticity of the metal capsule and therefore the calibration. If the corrosion is permitted to proceed, the cell will eventually fail completely. For this reason the cell is generally made with corrosion resisting materials.

4. Vacuum Errors

In addition to the general vacuum problems discussed in the general section on errors, the aneroid also has an evacuated sealed capsule which may leak. This is not usually a problem unless the cell has been tampered with, since leaky cells can be found after the aging period. If an instrument

Contrails

has a leaky cell, the zero will gradually shift and the atmospheric pressure reading will shift.

5. Determination of Errors

If the gauge is pumped down to a pressure much lower than its minimum reading, the true zero can be determined. It may take some time to completely outgas the gauge and obtain a stable reading, particularly if the gauge is old or badly contaminated. The needle should coincide with the zero mark. Most of the errors causing the needle to differ from the dial zero will be corrected by readjusting the zero. This will not be true if the instrument was not completely outgassed when originally calibrated. If the zero is different by more than one dial division it should be recalibrated. For gauges which include atmospheric pressure in their range, this reading should be checked with a good barometer after the zero has been reset. On some gauges the lever system magnification can be adjusted. The high pressure point can be set with this adjustment. These procedures should be carried out at normal operating temperature.

C. BOURDON GAUGE

1. Principle of Operation

The Bourdon tube is a very old instrument generally used for pressures above atmospheric. It is a hollow tube of oval cross section, closed on one end and bent in a semicircle. The inner volume is connected to the unknown pressure and the external surface exposed to the atmosphere. If the pressure in the tube increases, the cross section tends to become circular which forces the semicircular shape to straighten out. If the open end is rigidly mounted, the closed end can be coupled mechanically to a dial pointer for reading the motion of the closed end and thus the pressure. Conversely, if the pressure in the tube is reduced, the tube tends to collapse and the semicircle then curls up.

The Bourdon tube gauge is primarily a rough indicator of pressure. Its sensitivity is low and the errors are large so that the Aneroid is preferred where accuracy is required. The pressure range can be up to thousands of pounds and as low as 10 mm, although not in a single instrument. Because

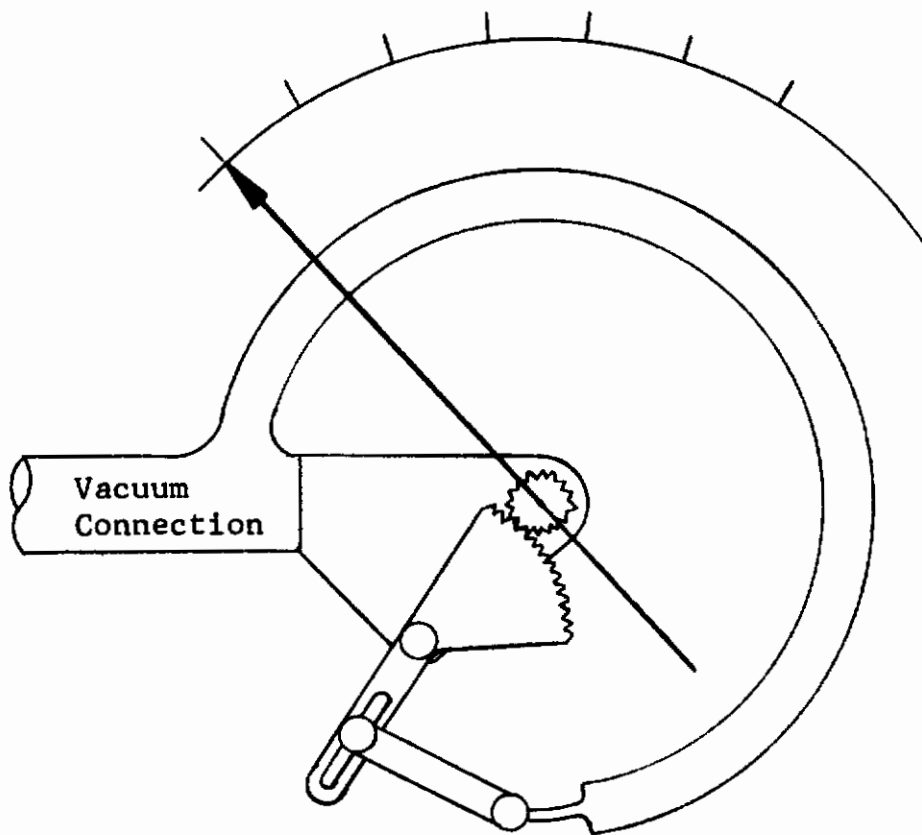

FIG. 7 BOURDON GAUGE

Contrails

it usually operates against atmospheric pressure, it is not an absolute pressure indicator but measures the difference from atmospheric pressure.

2. Errors

The errors in the Bourdon tube gauge are similar to those of the Aneroid and are all discussed under the Aneroid gauge. Hysteresis and temperature are the predominant errors since most Bourdon gauges are not temperature compensated.

D. DIAPHRAGM GAUGE

1. Principle of Operation

The diaphragm gauge is an extension of the Aneroid principle to even lower pressures. At pressures lower than about 1 mm, the force available to flex a diaphragm is very small - too small to overcome the inertia of a mechanical indicator. The small motion of a very thin diaphragm can be sensed and amplified by electric or electronic means. One method is to make the diaphragm one plate of a capacitor and sense the change in capacity electronically. Other means are also available. Since the thin diaphragm cannot deflect very far before the elastic limit is reached and because the motion is not linear with pressure, the diaphragm is usually returned to a null position by an external force which can be accurately determined. Another method, used where the atmosphere to be measured is highly corrosive or incompatible with other types of gauges, is to balance the diaphragm by adjusting the pressure on the reference side of the diaphragm with an inert ideal gas to null the diaphragm and then measure the reference pressure.

The accuracy is limited primarily by temperature effects. Even lower pressures can be sensed when the diaphragm is not intended to support full atmospheric pressure and therefore can be made very thin. Sensitivities down to 10^{-5} have been achieved but the accuracy at even 10^{-3} is questionable.

Diaphragm gauges as a class are fairly intricate and expensive. Instruments with high sensitivity are necessarily delicate and must be temperature controlled. They are sensitive to vibration and shock and there is always the

possibility of damaging the diaphragm by a sudden large change in pressure

2. Fundamental Errors

By using the null balance of the diaphragms, the errors caused by the elastic constant variations are eliminated. The fundamental errors then are associated with the measurement of the nulling force, and its stability and repeatability. In this case, the determination of the null point may also be considered a fundamental error because this is the reference.

3. Physical Errors

The major physical error is due to temperature. In most cases the temperature-caused variations are orders of magnitude greater than the sensitivity. Since the temperature variation affects only the zero, measurements made within a short time after setting the zero can use the available sensitivity, but over longer periods of time the precision will be progressively impaired.

The diaphragm gauge measures the difference in pressure from a reference pressure. The reference must be known to a better precision than the gauge or must be lower than the minimum sensitivity of the gauge.

If the gauge is subjected to pressures such that the diaphragm is stretched beyond the yield point, the zero will change and the sensitivity will probably change.

4. Electrical Errors

The electrical and electronic errors which affect the diaphragm gauge are those discussed in the general section on errors. In some types of gauges the diaphragm is returned to the null position by an electrostatic force between the capacitor plates which is determined by the voltage across the capacitor. Any error in setting, resetting or reading the voltage will increase the over-all error. Leakage across the capacitor may also contribute to the error.

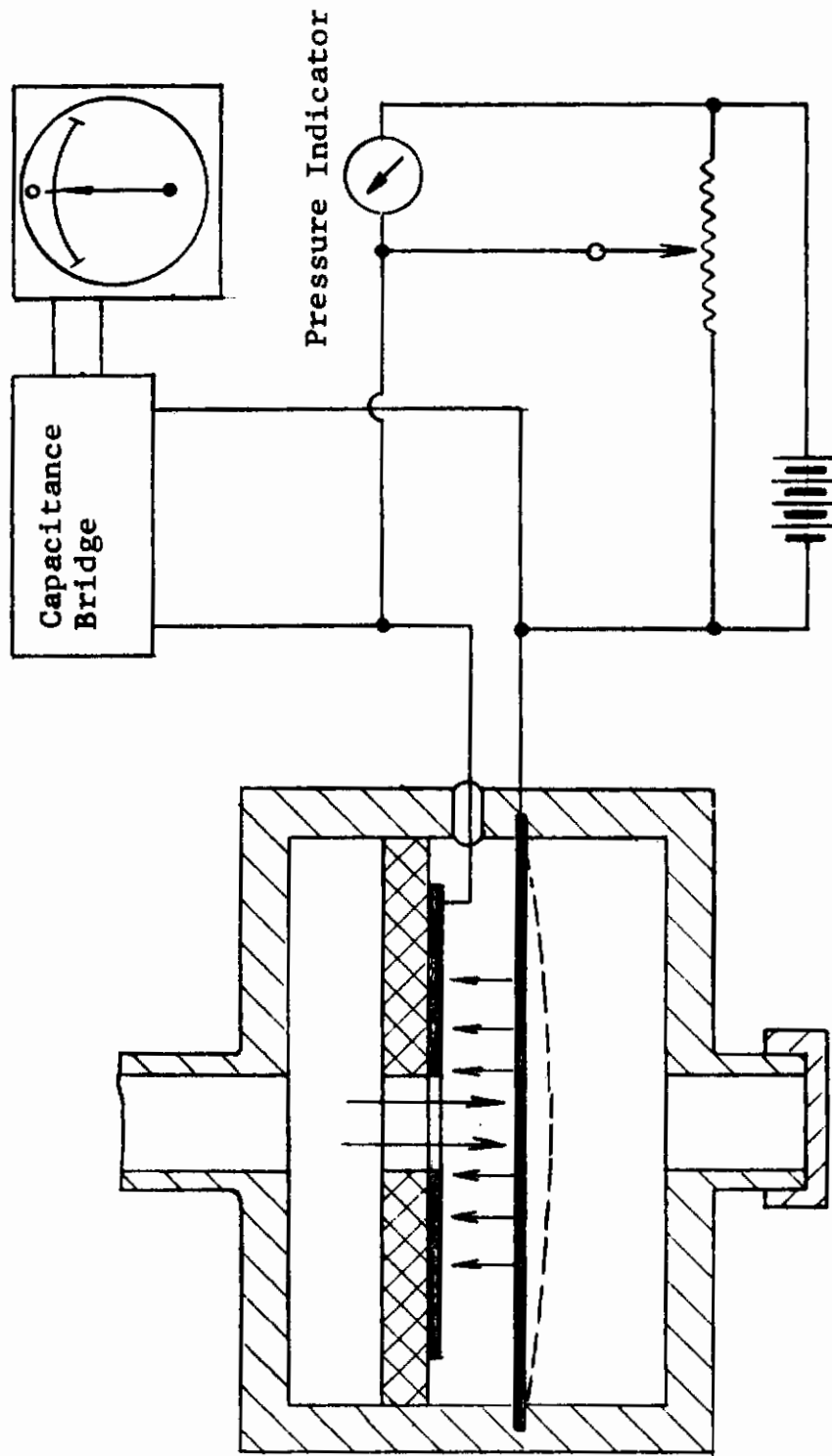

FIG. 8 DIAPHRAGM GAUGE

5. References

Rideal, Eric, A. J. B. Robertson, J. Sci. Inst. 32, 349 (1955).

Opstelten, J. J., N. Warmoltz, J. J. Zaalberg von Zelst, Appl. Sci. Res., Sec. B., Vol. 6, 129 (1957).

Opstelten, J. J. and N. Warmoltz, Appl. Sci. Res. B 4, 329 (1955).

Lilly, J. C., V. Legallais and Ruth Cherry, J. Appl. Phys. 18, 613 (1947).

Lovejoy, D. R., R. S. I. 32, 41 (1961).

Cope, J. O., R. S. I. 33, 980 (1962).

Lilly, J. C., R. S. I. 13, 34 (1942).

VI. MANOMETERS DEPENDING ON THE PHYSICAL PROPERTIES OF THE GAS

A. MOLECULAR GAUGE

1. Principle of Operation

The operation of a molecular gauge is very similar to a fluid clutch. A rotating vaned disc or cylinder imparts kinetic energy to the gas molecules in the direction of rotation. The gas molecules strike a second disc or cylinder mounted very close to the rotating disc, with a transfer of energy. The second disc is restrained by a spring so that the transferred energy will move it to an angular position depending on the number of gas molecules (pressure) and the energy. Since the energy is dependent on the speed of the driven disc as well as on the mass of the gas molecule, the gauge is sensitive to the composition of the gas. The speed of the rotating disc is controlled by driving it with a synchronous motor. A dial pointer is mounted on the axis of the second disc to indicate the angular position or pressure.

The gauge is not very widely used partly because of its composition dependence but mainly because the accuracy is so poor. (See Table 4.) It does have advantages where high accuracy is not required: simple to operate, rapid response, and does not contaminate the system.

2. Fundamental Errors

The basic equation which describes the operation of the molecular gauge is:

$$B = KuP\sqrt{\frac{M}{T}}$$

where

B is the rate of momentum transfer per unit area

K is a constant depending on the nature of the gas and the accommodation coefficient for the transfer of momentum

u is the velocity of rotation

TABLE 4
MOLECULAR GAUGE ERRORS

Pressure Reading	Error
0	$\pm 1 \times 10^{-3}$ torr
1×10^{-2} torr	$\pm 2.5 \times 10^{-3}$
2×10^{-2}	$\pm 3.5 \times 10^{-3}$
3×10^{-2}	$\pm 4 \times 10^{-3}$
5×10^{-2}	$\pm 7 \times 10^{-3}$
1×10^{-1}	$\pm 2 \times 10^{-2}$
3×10^{-1}	$\pm 4 \times 10^{-2}$
1	$\pm .5$
5	± 1.4
10	$\pm .75$
20	$\pm .75$

Contrails

P is the absolute pressure

M is the molecular mass

T is the absolute temperature

With the exception of P which is to be determined, any variation in these quantities will constitute an error. K is dependent on the gas composition as well as M. If the gauge is calibrated on one gas and used on another, the calibration will be in error. The velocity or rotation u is usually high and controlled by the power line frequency (where driven by a synchronous). Changes in line frequency will introduce errors. Changes in temperature introduce errors due to the basic equation and also in the physical apparatus as shown below. The basic temperature error can be corrected by measuring the temperature of the gas.

3. Physical Errors

The temperature errors described above are augmented by the change in spring tension on the captive disc with temperature. The error due to changing friction in the pivots of the captive disc may also be temperature sensitive. As in the Aneroid gauge pivot lubrication can be very critical because the forces to be measured are very small and any change in friction will introduce error.

4. Determination of Errors

Because the major errors in the molecular gauge are due to the fundamental relationships, the errors in a specific unit are hard to determine. Calibration of the unit with a standard manometer is probably the best method.

5. References

Briggs, N. E., 1954 Vac. Symp. Trans. pp. 3-6, Pergamon Press, Oxford (1955).

B. ACOUSTICAL GAUGE

1. Principle of Operation

The acoustical vacuum gauge is based on the damping effect of the gas pressure on a vibrating system. One form of the gauge is similar to a loud speaker (either moving coil or electrostatic) operating in the atmosphere to be measured. Another form is the piezo-electric crystal driven at its resonant frequency. In either case, the damping or loading on the vibrating member is a function of gas pressure. Several measurement methods may be used. The change in amplitude of the vibrating member may be sensed; the electrical impedance of the driving coil or crystal may be measured; or the amplitude may be held constant and the input energy may be measured. The damping is a function of the mass of the gas molecule and therefore is composition dependent. The largest pressure range reported for this type of gauge is 10^{-5} torr to atmosphere. The measurement of deflection gives a non-linear calibration curve but the measurement of input power is linear with pressure up to the point where the viscosity is no longer constant.

The diaphragm-type acoustical gauge is very similar to the diaphragm gauge - one operates in an a-c mode and the other a d-c mode - so that the temperature sensitivities would be similar. The quartz crystal-type should be much better, assuming a low temperature coefficient-type crystal.

Although commercial models are not yet available, the gauge appears to be a very good instrument. The wide range is very appealing as most of the gauges in this range cover only about three decades. The quartz crystal-type makes a very small sensing element and can easily be immersed in the vacuum system itself, eliminating gauge envelope and tubulation problems.

2. Errors

In order to obtain maximum amplitude and therefore maximum sensitivity, the vibrating member is driven at its natural frequency. The resonant frequency will change with pressure, so some feedback means is generally employed to adjust the driving frequency to match the vibrating system. This system

must be reliable and repeatable if the gauge is to have stability of calibration.

The temperature problem has been mentioned above. Here the problem is changing tension on the diaphragm with temperature. This will of course change the natural frequency and amplitude. If the gauge is operated at constant amplitude and always at the natural frequency, there is inherent compensation for these temperature effects. This should also be true for aging or fatigue effects of the diaphragm.

Because the gauge senses the loading on the vibrating system, it will also be sensitive to deposits of any kind on the vibrating member. The system must be clean and stay clean and free from pump oil and other condensibles.

The gauge is sensitive to composition because the loading is a function of the mass of the gas molecule. Non-linearities which appear at the high pressure end of the range where the mean free path is less than the amplitude of vibration are also dependent on the species of gas molecule. The knee of the curve is displaced along the pressure axis for different gases.

The crystal-type sensing element requires driving power at very high frequency. At these high frequencies, losses in the cable leads are dominant factors in total losses. Good grade coaxial cables must be used and care must be taken to keep the insulating surfaces clean (plugs, etc.). Aging effects in the cable can cause long term increase in losses in the cable, which will shift the calibration curve. Other errors due to electronic circuits are discussed in the general section.

3. References

Schwarz, Helmut J., 1956 Vac. Symp. Trans. pp. 37-38, Pergamon Press, Oxford (1958); 1961 Vac. Symp. Trans. pp. 467-71, Pergamon Press, Oxford (1962).

Pacey, D. J., Vacuum 9, 261 (1960).

Dimeff, John, J. W. Lane and G. W. Coon, R.S.I. 33, 804 (1962).

Contrails

Antal, J. and A. Konig, Periodica Polytechnica Elec.
Eng. 1, 297 (1957).

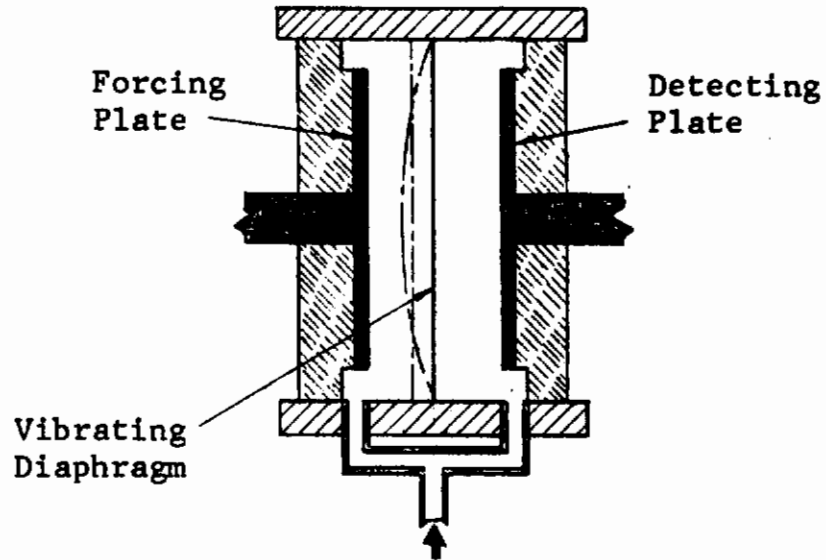

FIG. 9 ACOUSTICAL GAUGE SENSOR

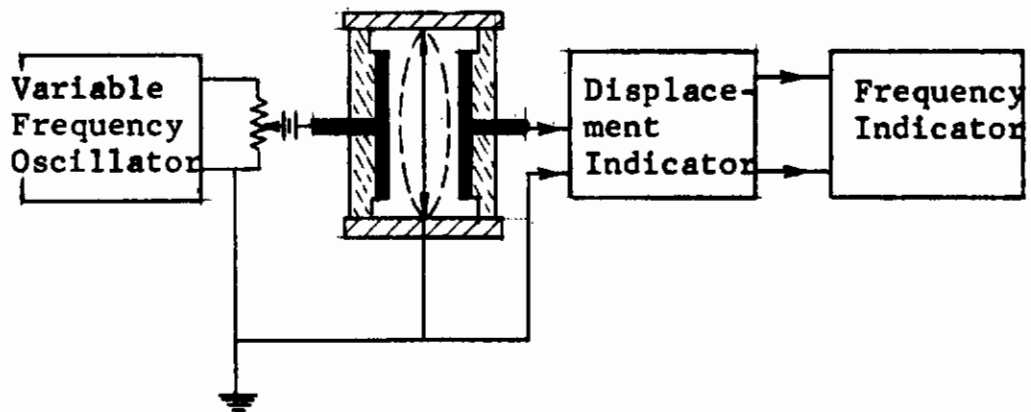

FIG. 10 ACOUSTICAL GAUGE CIRCUIT

VII. MANOMETERS DEPENDING ON THE THERMAL PROPERTIES OF THE GAS (THERMAL CONDUCTIVITY GAUGES)

A. GENERAL

Thermal conductivity gauges measure gas pressure by sensing the heat transfer by the gas from a hot wire to the walls of the gauge. At high pressure there are more molecules available to transport the heat away from the wire, at low pressure fewer molecules are available and the wire tends to become hotter. Several different methods are used to sense the temperature of the wire as well as several ways to operate the gauge electrically.

The Pirani gauge senses the temperature by measuring the resistance of the hot wire; the thermocouple, as its name implies, uses a thermocouple and similarly the thermopile. All of these gauges use the same physical principle for pressure measurement. Each of the gauges may be operated under constant voltage, constant current, or constant temperature conditions. Under the first two conditions the temperature change is the indicated quantity and calibrated against pressure. In the third case the power input is the indicated quantity. Constant voltage and constant current modes have been popular for many years in standard commercial circuits with pressure ranges from 10^{-3} torr to one or two torr because they use simple circuits and are reasonably inexpensive to build. The constant temperature method gives a wider pressure range, but it has only been recently that automatic temperature control circuits have been used commercially. The pressure range of thermal conductivity gauges is theoretically very wide. However, in actual practice the range has been limited to 10^{-3} torr to 1 or 2 torr. The upper end has been limited because, in the usual mode of operation (constant voltage), the temperature of the wire approaches room temperature - the wire and the wall are at the same temperature so that no further change can take place. When operated under constant temperature conditions this is no longer true, and the instrument will operate to much higher pressures.

The lower end of the pressure range is limited by loss of heat by conduction through the leads and by radiation. By careful design and selection of wire material to reduce radiation loss (emissivity) gauges have been able to sense

Contrails

pressures down to 10^{-5} torr. However, the temperature variation of the wall becomes very critical so that special care must be taken to maintain constant wall temperature. Tungsten or platinum are usually used for the wire material because they remain clean and bright for low emissivity over longer periods. These gauges have found wide use as pressure indicators, in the middle vacuum range. Although the accuracy is generally very poor, their cost is very modest.

1. Errors

In this general section on thermal conductivity gauges, the errors common to the class will be discussed. Errors peculiar to the individual gauge will be discussed under the particular gauge heading.

2. Fundamental Errors

Heat transfer by the conduction of heat by the gas molecules is the basic variable with gas pressure. Other modes of heat transfer are assumed to be constant. There are a number of factors which affect this basic process. Heat transfer from the hot wire to the gas depends on the surface condition of the wire as well as the type of gas molecule. The heat transfer from the gas to the wall also depends on these factors. The temperature of the wire will therefore depend on these surface conditions as well as the composition of the gas. In order to maintain a clean surface on the wire, platinum or tungsten are generally used because they will not react with contaminants in the vacuum system.

Changing surface conditions (oil vapor or other condensable films, corrosion, etc.) inside the gauge are hard to predict so that the errors are not easily determined without recalibration. The heat transfer depends also on the temperature of the wall so that if the gauge is operated with wall temperatures different from the calibration temperature, errors will result. Temperature errors are generally compensated for in the Pirani gauge by the use of a second sealed-off gauge.

3. Physical Errors

Unfortunately, the other modes of heat transfer are not necessarily constant. Heat is also removed from the

Contrails

hot wire by conduction through the leads and by radiation. Conduction through the leads will depend primarily on the construction of the wire mounting and the difference in temperature between the wire and ambient temperature. Radiation from the wire will again depend on surface conditions - emissivity - absorbtivity - of the wire and the wall of the gauge. Errors due to wall surface conditions are usually small in glass enclosed gauges not only because the glass surface does not corrode, but the dirty surface can be seen and therefore is cleaned more often. As indicated above, the emissivity of the wire must remain low and constant - the wire must stay bright. In many cases if the wire does become contaminated, it can be cleaned by operating at red temperatures in a vacuum for a short period. However, aging of the wire does cause permanent changes in the emissivity. Small changes can be corrected by rebalancing the bridge at zero pressure.

B. PIRANI GAUGE

1. Principle of Operation

The Pirani gauge is a thermal conductivity gauge which senses the change in temperature of the hot wire by resistance measurement. The gauge element is simply a long thin wire wound in a helix, mounted in a glass tube which is connected to the vacuum system. The ends of the wire are connected to two leads which feed through the glass wall. An ordinary electric light bulb will operate as a Pirani gauge. The gauge is connected in a Wheatstone bridge circuit with stable resistors. The bridge circuit can be adjusted to heat the wire and measure small changes in resistance. See Figure 11.

Because the gauge is sensitive to ambient temperature, it is usually used with a second matched gauge which is pumped out and sealed. The compensator gauge is connected to the adjacent leg of the bridge and thus balances the temperature component in the sensing gauge. Another arrangement is to mount the gauge in a constant temperature bath.

With the advent of thermistors, semiconductors with very high temperature coefficients of resistance, attempts have been made to use these devices as a Pirani gauge element. The increased sensitivity permits operation at lower temperatures, so that the radiation and conduction losses

Contrails

are smaller and lower pressures may be indicated. However, ambient temperature compensation is a problem. At different pressures the temperature coefficient is not constant, so a sealed-off compensation cannot be used effectively.

2. Errors

The errors discussed in the general section on Thermal Conductivity Gauges apply to the Pirani gauge. In addition, there are the electrical errors peculiar to the Pirani and its circuit.

In the constant voltage mode of operation, the bridge circuit is designed to heat the gauge to a temperature between 300^o and 400^oC at essentially zero pressure.

If during operation the supply voltage to the bridge changes, the temperature of the wire will change. If the voltage increases, the temperature will increase and all readings will be lower than the true pressure, and visa versa.

The bridge circuit components may contribute errors due to changes with ambient operating conditions. A change in resistance of any individual resistor in the bridge will cause a change in the meter reading. These errors are reduced by using a compensator gauge and two matched resistors as the arms of the bridge. As long as each pair has the same sensitivity to ambient conditions, the changes will balance out.

Operation of the gauge in the constant temperature mode has one additional source of error. The temperature of the wire does change a small amount over the pressure range. The actual change is determined by the gain in the feedback loop. The gauge is calibrated with this normal change in temperature. If the amplifier in the feedback loop loses gain through aging or otherwise, the temperature variation will increase and an error will result.

3. References

There are so many references to thermal conductivity gauges it would be impractical to list them here. NBS Monograph # 35 has a very complete listing. Reference is

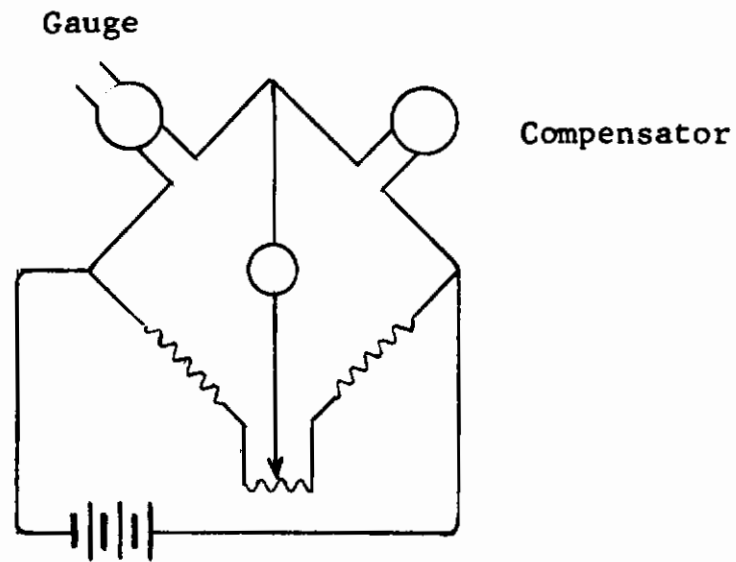
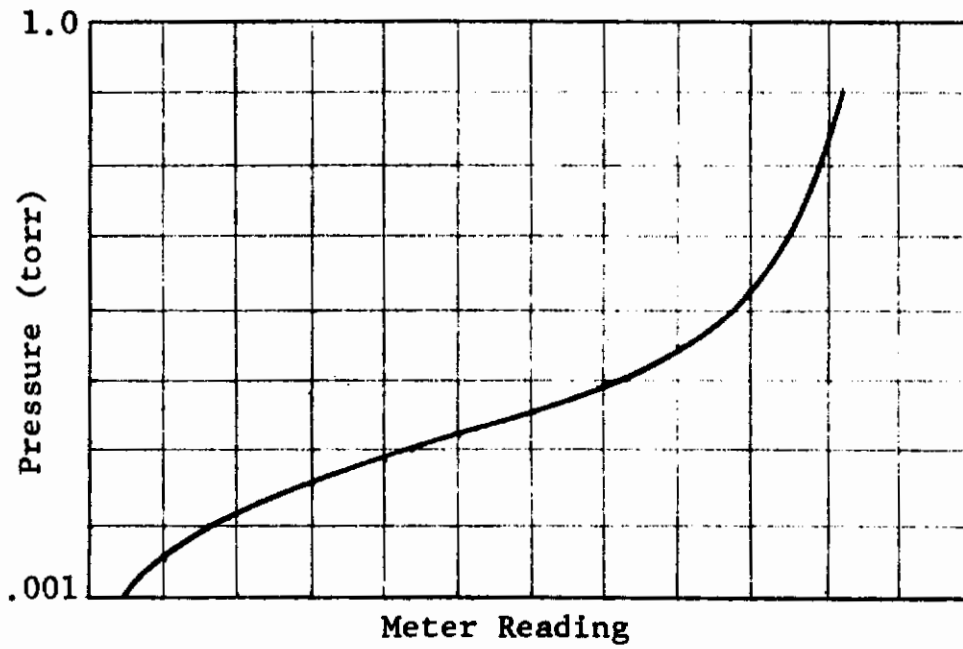

FIG. 11 PIRANI GAUGE

Contrails

also made to H. V. Ubisch, Applied Scientific Research A2, 364-430 (1951), for a very complete discussion of the principles and a long list of references.

C. THERMOCOUPLE GAUGE

1. Principle of Operation

The thermocouple gauge is a thermal conductivity gauge in which the change in temperature of the hot wire is sensed by a small thermocouple welded to the center of the wire. The gauge is usually operated under constant current conditions and a millivolt meter is used to read the thermocouple. It is the simplest and cheapest of the thermal conductivity gauges but also the most inaccurate. No attempt is usually made to compensate for ambient conditions. Each gauge is marked with a current rating to bring it to the proper temperature when new. After long periods of use, this current no longer supplies the proper temperature and the gauge is useful only as an indicator.

Although circuits have been designed for constant temperature use, most commercial gauges operate as constant current devices with a range of 10^{-3} to 1 torr. The gauge is very useful for checking forepump pressures and other applications not requiring high accuracy.

2. Errors

Because the circuit is very simple, there are few errors introduced. The major errors are indicated under Thermal Conductivity Gauges. The leads, plugs, and switches used in the thermocouple circuit can cause errors if the resistance in the circuit is not reasonably consistent. If long leads are used the manufacturer's calibration with short leads will not be correct.

The internal resistance of the millivolt meter is critical when used with a thermocouple. In commercial instruments this resistance is trimmed to a specific value with a small variable resistor. If the meter is changed, the total resistance-meter and trimmer must be as specified or errors will occur.

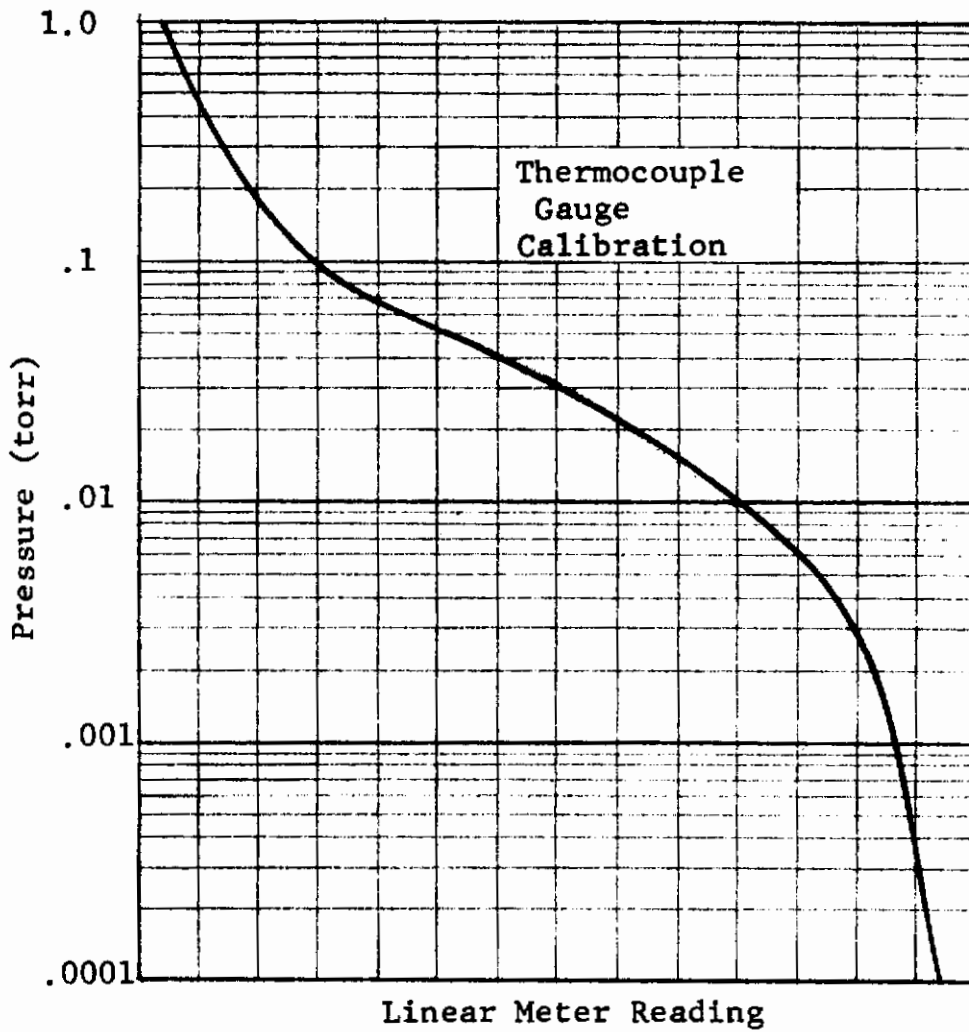

FIG. 12 THERMOCOUPLE CALIBRATION CURVE

Contrails

The calibration supplied with the gauge depends on the true value of the heater current. Any errors in the metering devices used to set the current will change the calibration. This may include rectifiers and resistors since the heater current is usually A.C. and the current may be monitored on a D.C. meter.

3. Minimizing Errors

Contamination and aging effects are the predominant errors in thermocouple gauges. Good cleaning procedures are necessary with all vacuum gauges to reduce contamination errors. The aging effects can be reduced by re-determining the proper heater current. With the gauge pumped down well below 1 micron the heater current is adjusted so that the pressure indicator reads zero. By using the new heater current setting the printed scale will be more nearly correct.

D. THERMOPILE GAUGE

1. Principle of Operation

The thermopile gauge is an extension of the thermocouple type in which a series of thermocouple junctions butt welded together form a thermopile. The alternate junctions are made thick and thin. When heated by passing a current through the series, the thin junctions become hot and the thick junctions tend to remain cool. Two such piles are arranged in a bridge circuit so that the series string is heated with AC current and the thermocouple output is read on a DC meter.

Although single couples may be used, the pile provides greater voltage output. The cold junctions can be welded to support wires in the multiple feed through leader for even greater output. As in the thermocouple gauge, the thermopile does compensate for ambient temperature conditions since the cold junctions are close to room temperature and vary with it. A third thermocouple or pile may also be inserted in the output meter lead for further temperature correction.

The gauge is usually operated under constant current conditions, and the usual range is 10^{-3} to 1 torr.

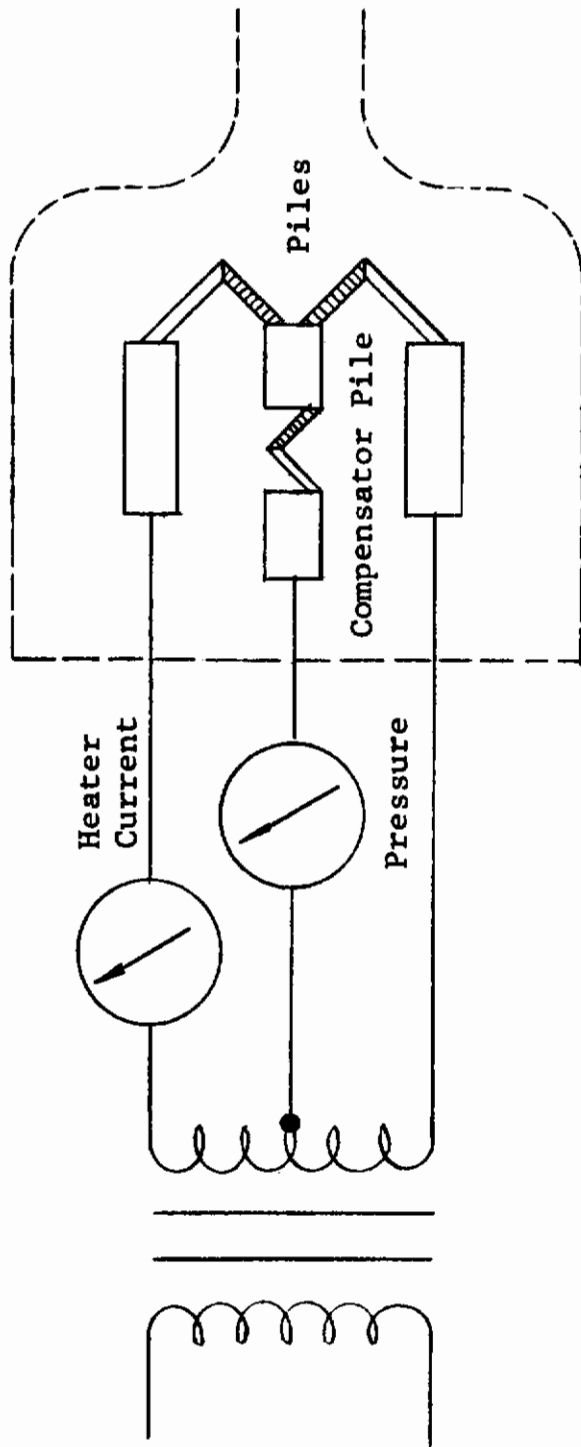

FIG. 13 THERMOPILE GAUGE

2. Errors

In addition to the errors common to all thermal conductivity gauges are the electrical circuit errors. The heating current must remain constant or errors will result. Most gauges are supplied with either constant current devices or a control and meter for setting the current. The lead length between the gauge and control box is critical. Long leads will increase the resistance in the thermocouple circuit which will reduce the sensitivity. (See also the thermocouple gauge.)

3. References

J. M. Benson, Sixth National Symposium on Vacuum Technology Transactions 1956, p. 87, Pergamon Press, Oxford (1957).

Marvin Bunker, Paper No. 54-43-2 Delivered at First International Instrument Congress and Exposition, September 1954.

J. M. Benson, 1961 Vacuum Symposium Transaction, pp. 489-93, Pergamon Press, Oxford (1962).

C. E. Hawk, Fourth Nat. Symp. on Vac. Tech. Trans. p. 14, Pergamon Press, Oxford (1955).

E. KNUDSEN GAUGE

1. Principle of Operation

The Knudsen gauge measures pressure by measuring the force produced by heated gas molecules striking a given small area. One arrangement is shown in the diagram. Two fixed surfaces B are heated. The two strips A are mounted on a torsion spring S with a mirror M. Gas molecules striking surface B rebound with a higher velocity corresponding to the temperature of B. These molecules strike the vane A and repel the vane away from B against the force of the torsion spring. The movement of the vane is detected by the motion of a small spot of light reflected from the mirror. If the distance between the heated surfaces and the vanes is less than the mean free path (the probability of striking the surface is much higher than striking another gas molecule)

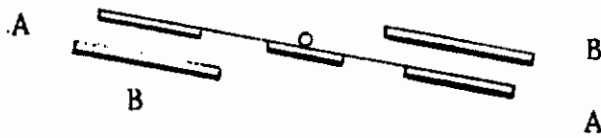
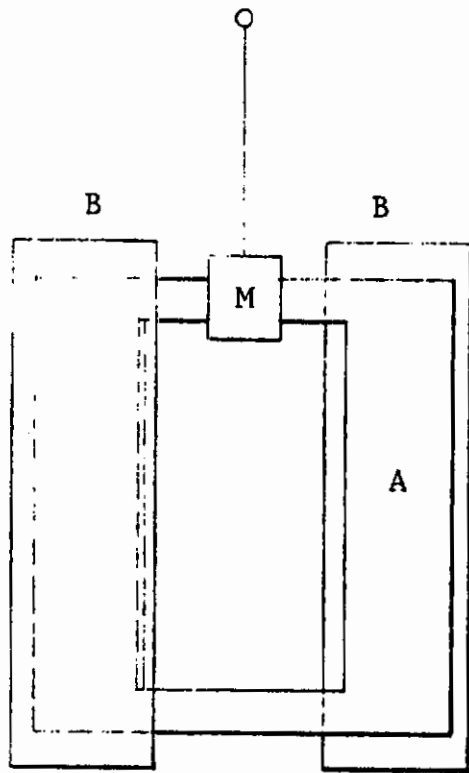

FIG. 14 KNUDSEN GAUGE

Contrails

the rate of momentum transfer per unit area is determined by the pressure and the difference in temperature. The gauge can be considered an absolute gauge since the pressure can be determined by measurements of the area of the vane, the two temperatures and the return force of the spring on the vane. This assumes that the accommodation coefficient for momentum transfer is unity for all gases.

Because it is very difficult to measure the temperature of the heated surface (the temperature changes with pressure due to thermal conductivity of the gas) and the true value of the accommodation coefficient is not known, the gauge is usually calibrated with a McLeod gauge. One of its big advantages is that it is not very sensitive to gas composition and will measure total pressure including condensible vapors. (The differences in accommodation coefficient between gases is small.)

The suspension for the moving vanes is a very delicate system since it measures very small forces. This requires that the gauge be mounted on a very solid foundation free from vibration. Because the suspension has a very low natural frequency, magnetic damping is usually provided. This also helps the vibration problem. The gauge sensitivity can be changed by changing the temperature of the heated vane. Several pressure ranges can be provided by step changes in temperature.

Because the projected area of the vane facing the heated plate changes with rotation of the vane, large rotation angles will change the calibration. It is for this reason the gauge is sometimes used as a null balance indicator with an electric or magnetic restoring force to balance the momentum forces. In this case the pressure is determined by an electrical measurement of the restoring force.

2. Fundamental Errors

If the gauge is used as an absolute manometer the fundamental errors include the basic measurements of temperature, area, and the torsion spring force on the vane. Since the accommodation coefficient is unknown but assumed to be one or very close to one, (and comparison with a McLeod gauge indicates that this is true), the error between the true and assumed value will be a fundamental error.

3. Physical Errors

If the gauge is not used as an absolute manometer but calibrated with a McLeod gauge, some of the previously mentioned errors become physical errors. The temperature of the cold surface is affected by the ambient temperature and since the rate of momentum transfer depends on the temperature, the calibration will be affected by ambient temperature. Operation of the gauge in a constant temperature environment will help this problem. Likewise, the torsion spring constant will change with temperature. The accommodation coefficient does not enter directly since the gauge is calibrated. However, if the accommodation coefficient is not the same for all gases, errors will occur when the gauge is used with gases for which it has not been calibrated.

The temperature of the hot surface must either remain constant or change in the same manner with pressure as when the gauge is calibrated. The surface is usually heated electrically. Errors which occur in providing the proper power to the surface could be in the electrical error category but in this case it is the resultant temperature error that affects gauge performance. A measurement of the electric current is probably the easiest method to reset the temperature to a fixed value.

If the gauge is operated at pressures where the mean free path is less than the distance between the hot and cold surfaces, the gauge calibration will not be linear and will be different for different gases. As the pressure increases above this linearity break, the momentum transfer decreases at an increasing ratio so that the gauge will indicate decreasing pressure when the pressure is in fact increasing.

Errors will also occur, when using the absolute calibration, if the angular movement of the vane becomes large. As the vane rotates the projection of the area looking toward the hot surface becomes smaller, thus intercepting fewer gas molecules.

4. Vacuum Errors

The Knudsen gauge is useful only in the lower pressure region where outgassing is a problem. High temperatures are

Contrails

usually deleterious due to possible changes in the spring constant. At very low pressures long periods of time are required for the gauge to come to equilibrium with the system pressure (tubulation between gauge and system is a factor here). It will also take some time for the hot surface to come to equilibrium after the heater power is turned on. This will be particularly so if the surface is contaminated with pump oil or other condensed vapors.

5. Determination of Errors

One advantage of the Knudsen gauge is that the true zero can be found at any time by turning off the heater power and permitting the hot surface to come to ambient temperature. With no net exchange of momentum transfer the gauge will read zero. Changes in zero may be due to ambient temperature changes, or changes in the mechanical suspension due to shock or vibration.

6. References

Dumond, J. W. M. and W. M. Pickels, Jr., R.S.I. 6, 362 (1935).

Fryberg, G. C. and J. H. Simons, R.S.I. 20, 541 (1949).

Miller, G. A., R.S.I. 33, 8 (1962).

Onchi, M., 1961 Vac. Symp. Trans. p. 544, Pergamon Press, Oxford (1962).

VIII. MANOMETERS DEPENDING ON THE ELECTRICAL PROPERTIES OF THE GAS (ION GAUGES)

A. GENERAL

The ion gauge is a low pressure manometer which determines the pressure by counting a constant fraction of the molecules in a fixed volume. A stream of electrons or other radiation is used to ionize the gas and the positive ions are collected and the ion current measured. If the number of electrons is constant and their average path length and energy are constant, the ion current is directly proportional to gas density.

The standard ion gauge is constructed as a normal triode radio tube. A hot filament is surrounded by a grid structure which is in turn surrounded by a plate. Electrons produced by the hot filament are accelerated to the grid which in this case is at positive potential. Many of the electrons are not immediately captured by the grid but traverse the space between the grid and the plate. During the travel of the electrons, some of the gas molecules with which they collide will be ionized (this is a fixed number per unit path length depending on the ionization cross section of the gas and the electron energy). The positive ions in the space between the filament and the grid will be collected at the negative filament. The ions formed in the space between the grid and the plate will be collected at the plate which is a few volts negative with respect to the filament.

The control circuit for an ion gauge includes all the voltages necessary and usually a feedback circuit to maintain the electron current at a constant value, and an ion current amplifier. By selecting the proper electron current the ion current meter will read directly in pressure. Pressures from 10^{-3} to 10^{-8} torr may be read by a range selector switch.

The ion gauge is limited to reading pressures below 10^{-3} because the hot filament will oxidize very rapidly at higher pressures. Many gauges become non-linear at the higher pressures because of space charge effects and recombination of the ions. When the mean free path of the ions becomes small compared with the dimensions of the gauge, the probability is high that they will collide with an electron and become neutralized before they reach the collector.

Contrails

There are a number of different types of ion gauges designed for specific uses and a number of modifications for improved performance. These types are discussed individually under separate headings. All types of hot cathode ion gauges can be supplied with filaments made of special materials such as iridium and thoriated tungsten which permit operation at much lower temperature. Operation at higher pressures is possible with these filaments and some can withstand atmospheric pressure for short periods.

As lower and lower pressures are reached, special problems arise in trying to measure the pressure. The gauge can act like a pump or it can be a source of gas and the proper procedure for using the gauge becomes more of an art than a science. This is very true of the ion gauge. Part of the problem is due to the hot filament which can be a source of gas. In addition, the filament heats other parts of the gauge and long periods of time may be required before the gas density inside the gauge comes to equilibrium with the system. Further electrons and ions will drive gas molecules off of the surfaces which they strike as well as drive molecules into these surfaces.

The filament of an ion gauge is usually tungsten although other materials are sometimes used for special purposes. A new filament contains many impurities. The surface impurities and contamination will come off quickly when the filament is heated, but the bulk impurities take quite some time to diffuse through the metal. Even after the bulk metal has become quite clean, if the gauge is operated at reduced temperature, the tungsten will act like a sponge and adsorb gas. In a particularly dirty system it can increase the work function enough to seriously affect the electron emission so that the emission control circuits will not function properly. If the temperature is again increased, large amounts of gas will be liberated and the filament will become clean again. In either case, the gauge cannot be expected to read properly unless equilibrium is achieved.

The grid of the gauge and the glass walls act in much the same way. When a dirty gauge is turned on large amounts of gas will be liberated by the bombardment of electrons and ions. If the surfaces are clean, the electrons and ions will drive molecules of gas into the bulk material to which

Contrails

they will become tightly bound. This is the same principle used in an ion pump. The pumping is of course proportional to the number of electrons, so that it can be reduced by operating the gauge at low emission currents.

In order to speed up the process of cleaning up the internal parts of the gauge, electrical circuits are usually included in the gauge control to heat the grid to red heat either by electron bombardment or by resistance heating. Radiation from the hot grid heats up the walls of the gauge which drives off the gas more quickly. Electron bombardment has one advantage in that the filament is maintained at a higher temperature than in normal operation, and therefore will stay clean. However, this also reduces the life of the filament. Electron bombardment also requires a more expensive power supply and it cannot be left unattended. As the filament cleans up, the emission will increase; similarly, as the grid becomes clean, the radiation will decrease and it will become hotter. If not attended, there is the possibility of melting the grid or the glass, or both.

Resistance heating of the grid has several advantages but if not used properly it may be less effective. The power supply is less expensive and outgassing can proceed with little attention. The outgassing time is somewhat longer since no high energy electrons are present. Operation of the gauge is possible during outgassing but great care must be exercised if filament contamination is to be avoided.

Outgassing an ion gauge is generally not necessary at pressures above 10^{-6} torr and may even be detrimental. If much oxygen is present, the hot elements may become oxidized. The oxide layer will cause trouble at lower pressures because it will degas very slowly and because of its higher emissivity will prevent the grid from reaching the high temperatures necessary for good outgassing.

The performance of an ion gauge is sensitive to the tubulation connecting the gauge to the system. The use of large diameter short tubing will reduce the effects of outgassing and pumping of the gauge. With small long tubing the gauge may indicate pressure orders of magnitude different from the system pressure. For this reason, nude gauges - gauges immersed directly in the vacuum system - are becoming more popular.

1. Errors

In general, the ion gauge has been a very useful instrument. However, it has been primarily an order of magnitude indicator. Commercial gauges, used as received and operated at the recommended emission current cannot be considered accurate instruments. The emission current recommended by the manufacturer is an average for a small group of production gauges. Due to manufacturing tolerances in the physical geometry of the gauge and the test requirements of the control boxes, different systems even from the same manufacturer may differ by as much as a factor of 3 in reading the same pressure. On the other hand, a gauge and its control, when individually calibrated and properly used, can indicate true pressure of a single known gas to $\pm 10\%$ or better.

2. Fundamental Errors

The basic concept of the ion gauge is that the ion current is proportional to pressure. For this to be true, several requirements must be met. The number of electrons emitted (electron current or emission current) must be constant. The average path length of the electrons in the ionizing volume of interest must be constant, all of the ions must be collected, the gas composition must be constant, and the temperature must be constant (to relate density to pressure).

The first of these requirements is not strictly true since the ratio of ion current to electron current is also proportional to pressure. However, most commercial ion gauge control units include a circuit for stabilizing the emission current and reading the ion current as pressure. Any deviation in the electron current, unless corrections are applied, will constitute an error in the reading. The second requirement, average path length, is primarily a function of the applied voltages, although, if the structure is not rigid, changes in geometry may change the path length. The electron accelerating voltage must be constant and the collector voltage also. The characteristic voltage curves for many gauge tubes show little variation as long as the voltages are above a certain value. However, in some gauge control boxes the collector voltage is a function of the electron current and in some the voltage is a function of the ion current. If high accuracy is required all of these

parameters must be under control.

Because the ion gauge really measures molecular density, the temperature dependence of the density-pressure relationship must be considered. This dependence is, of course, with absolute temperature so that small variations have little effect. However, large changes in envelope temperature will cause large changes in gauge reading. Temperature changes will also change the outgassing rate of the glass wall and this usually tends to override the density-pressure change.

3. Electrical and Electronic Errors

Because the ion gauge is an electronic instrument, most of the errors appear in this category. In addition to the basic errors in the gauge tube mentioned above, are changes in ion collection efficiency and ionizing radiation from other sources.

At both ends of the ion gauge range non-linearities appear. At the upper (high pressure) end of the range, the gauge shows a loss in sensitivity. This is probably due to either recombination of the ions before they are collected or a space charge formed by the many more electrons. In any case it has been shown that linearity can be restored by reducing the electron emission. This reduces the number of ions and electrons so that the probability of recombination is less and the space charge is reduced. Emission currents as low as 10 μ A may be necessary to obtain good linearity over 1 micron pressure.

Because the ion gauge depends on a constant or known flux of ionizing particles, any additional source of ionizing radiation entering the ion chamber will cause errors. This may be a problem in areas where radioactive material is located near the gauge or when a component of the gas being measured is itself radioactive. Two or more ion gauges operated on the same system so that electrons from one can enter the other and will show differences in reading when both or only one gauge is in operation.

The low end of the pressure range is non-linear due to a limiting constant collector current. This current is caused by the x-ray effect. Soft x-rays are produced at the

Contrails

grid by the electron stream. The x-rays strike the collector, driving off electrons by secondary emission. Since electrons leaving the collector produce a current in the same direction as when positive ions are collected, a constant apparent ion current is produced. In the standard ion gauge this current is equal to the normal ion current at about 10^{-8} torr. Newer gauges have been designed to reduce or eliminate this lower limit.

The control and measuring circuits associated with gauge operation, with the exception of the ion current amplifier, have been discussed under fundamental errors. The ion currents, particularly at low pressures, are very small and must be measured with a current amplifier. In order to measure these very low currents, the input circuit of the amplifier operates at very high impedance levels up to 10^{12} ohms. At these levels the amplifier is susceptible to many environmental disturbances; moisture, dirt, AC hum, high frequency radiation, and insulation resistance. A shielded well-insulated cable between gauge and amplifier is a first requirement. The collector lead insulation (usually the glass bulb) on the gauge must be clean both inside and out. The internal surface is especially vulnerable to evaporation of metal from the filament or even from the grid during outgassing. Most gauges are constructed so that the internal collector insulation is in a shadow so that evaporated metal cannot form a continuous leakage path. This problem can also involve the grid to filament insulation. If a low resistance path is formed here the true electron current will not be displaced on the emission current meter. The meter reading will be the sum of the current due to the leakage in this path and the true electron current.

The ion current amplifier sensitivity is generally set by the manufacturer to a given value in relation to a standard ion gauge sensitivity (usually $100 \mu\text{A}/\text{micron}$ or $10 \mu\text{A}/\text{micron}$). This permits interchangeability of gauge tubes if they are operated at the recommended emission current. Because the sensitivity is adjustable by means of a screw driver operated control in the unit the stability of the amplifier sensitivity is unfortunately related less to design and construction than it is to the number of operators with handy screw drivers. In some cases control boxes have an interval calibration position on the range switch. This is advantageous for correcting these errors.

Some ion gauges are supplied with more than one filament to increase the useable life of the gauge. The extra filaments should also be heated when the other elements are outgassed. Also, the calibration for one filament is not necessarily the same for all filaments. Differences of as much as 30% have been recorded.

B. SCHULZ PHELPS GAUGE

1. Principle of Operation

The Schulz Phelps Gauge is an ion gauge designed to provide an ion current linear with pressure above the range of the standard ion gauge. The factors causing non-linearity above 10^{-3} torr have been eliminated by construction of the gauge with very small interelectrode spacing and low sensitivity. The gauge consists of a filament and two plates biased so that one will collect electrons and the other ions. The filament area is small compared to the ion collector and its voltage with respect to the two plates is adjusted so that it does not distort the field distribution between the two plates. In this way, most of the ions are collected by the ion collector. The low sensitivity and small spacing reduce the probability of ion recombination and eliminate the electron space charge effect. (See general section on ion gauges.)

The range of the gauge is 1 torr to 10^{-5} torr. The lower limit is again set by a larger x-ray current due to the close element spacing.

The gauge is primarily designed for back filling of vacuum tubes and vacuum furnaces with inert gases. If active gases are present the hot filament will have a very short life unless special materials are used (thoriated iridium, etc.).

With the exception of the pressure limits, the errors discussed in the general section on ion gauges apply to the Schulz Phelps gauge.

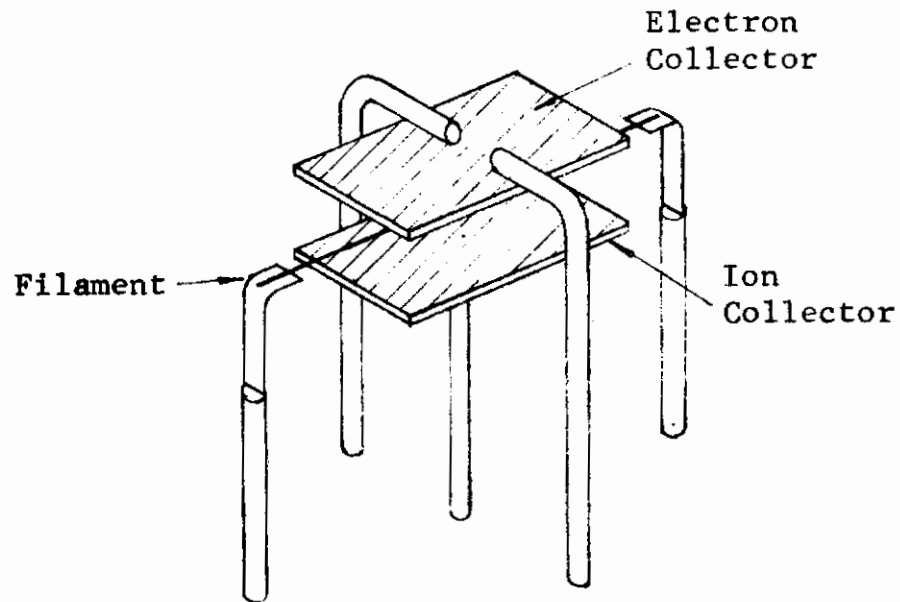

FIG. 15 SHULZ-PHELPS HIGH PRESSURE ION GAUGE

C. BAYARD-ALPERT ION GAUGE

1. Principle of Operation

The Bayard-Alpert gauge or inverted ion gauge was designed to reduce the x-ray effect and thereby enable the gauge to read lower pressures. In the standard ion gauge, the collector is a circular plate entirely surrounding the other elements. Almost all of the x-rays originating at the grid strike the collector plate. The large secondary electron current from the plate limits the gauge to a pressure approximating 10^{-8} torr. In the Bayard-Alpert gauge the elements are inverted - the filament is on the outside, the grid in the normal position and the collector a fine wire concentric with the grid. With this construction only a small part of the x-rays emitted from the grid will strike the collector. This reduces the x-ray current by a factor of a hundred or more so the pressure range is extended to 10^{-10} torr or a little lower depending on the diameter of the collector wire.

While this gauge is a great improvement over the standard ion gauge, new problems also arise. Because the standard gauge is almost completely enclosed by the collector plate, the electrons and extraneous ions formed in the space between filament and grid are confined and are all collected at the grid or filament. The Bayard-Alpert structure, however, permits the electrons to make wide excursions in the space between the structure and the envelope. Bombardment of the glass envelope by electrons and ions can charge the glass to large potentials which can disturb the electron trajectories. Under these conditions the gauge can operate in a very erratic manner and even break into oscillation. These problems led to the development of the Nottingham gauge.

Except for these problems, all of the errors discussed under the General Ion Gauge section apply to the Bayard-Alpert gauge.

D. NOTTINGHAM ION GAUGE

1. Principle of Operation

The Nottingham gauge is a further development of the Bayard-Alpert inverted ion gauge. In order to eliminate the

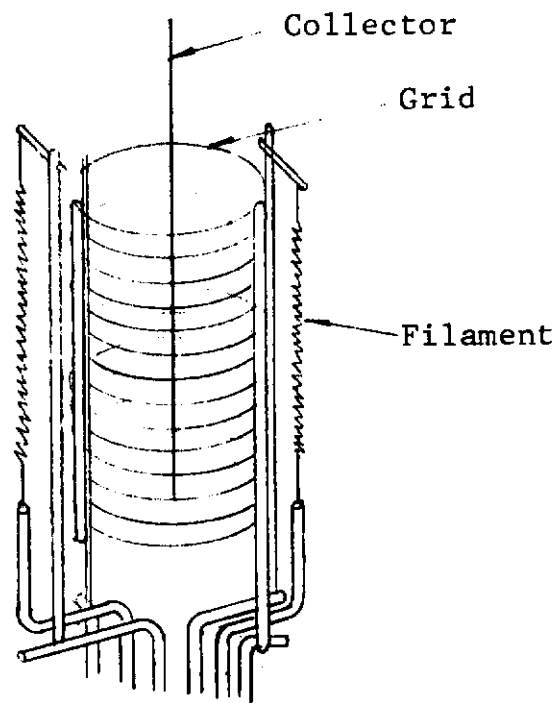

FIG. 16 BAYARD-ALPERT ION GAUGE

effects of the charged glass wall, Professor Nottingham installed a shield grid surrounding the entire gauge structure. His design also included end shields on the inner grid to prevent the ions of interest from straying to the outer grounded shield grid. Although the gauge takes longer to outgas with the additional large shield grid, the performance is not subject to the problems of glass wall charge effects. Many commercial models of the gauge use a platinum coating on the inside of the glass to obtain the same results. In this case, the coating cannot be directly outgassed but depends on radiant heating from the grid. The coating can be troublesome if it is laid down over dirty glass. The coating will not adhere well and the submerged dirt takes a long time to outgas. If the platinum coating is not properly cured, it may also outgas for long periods. In some cases the gauge must be wrapped with insulation during outgassing so that the glass will come up to almost melting temperature in order to be adequately outgassed.

The discussion of errors in the General Ion Gauge section also covers the Nottingham Gauge.

E. HOT CATHODE MAGNETRON GAUGE (Lafferty Gauge)

1. Principle of Operation

The hot cathode magnetron gauge is an ion gauge in which the average path length of the ionizing electrons has been increased by the use of a magnetic field. The gauge takes the form of a magnetron with crossed magnetic and electric fields. The electrons provided by a hot filament are accelerated by the electric field but are forced in circular paths by the magnetic field. If the magnetic field strength is higher than the magnetron cut-off value the electrons continue in their circular path until deflected by collisions with gas molecules. In this way, the electrons travel very long path lengths, thus increasing the ionization by large factors without increasing the x-ray current. This increased ion current to x-ray current ratio permits measuring pressure down to about 10^{-14} torr. However, the ion current at this pressure is less than 10^{-15} amps which is very hard to measure. In order to improve the situation, an electron multiplier is added and the ions are focused on the first dynode of the ten-stage multiplier.

Contrails

The impact of the high energy ions (accelerated by 3000V) ejects electrons from the first dynode. These electrons are then multiplied through the ten stages to give a current gain of approximately 10^6 . This current is easily measured by a standard electrometer. The ion current to x-ray current ratio is also improved by this arrangement because the solid angle intercept of the x-ray emission is smaller and the gain at the first dynode is greater for the ions than for the x-ray photoemission. The final design of the gauge as reported in May 1963 should provide measurement capability down to 10^{-18} torr. This is, of course, a calculated value and has not yet been achieved in practice. At the high pressure end of its range, the gauge becomes non-linear due to space charge effects between 10^{-7} and 10^{-5} torr, depending on the electron current.

2. Errors

With the exception of the electron multiplier, the gauge is subject to the same problems and errors as other ion gauges (see general section on ion gauges). The electron multiplier introduces the additional error in gain stability. The gain of the multiplier is affected by the voltages applied as well as the surface condition of the dynode plates. Because the dynodes are emersed in the vacuum, the surfaces can be contaminated just in the pumpdown process. Thermal outgassing may or may not return the surfaces to the same condition each time the gauge is used. The use of the device on vacuum systems is new and until more experience has been obtained, the gauge should be calibrated at higher pressures during the pumpdown by comparison with another gauge in which there is confidence.

The magnetic field strength does not appear to be critical as long as it is above the magnetron cutoff value. However, recent information on the cold cathode magnetron gauge (which see) may apply also to the hot cathode gauge. (At lower pressures the calibration curve changes from a linear function to a power function and the point of departure may be dependant on the magnetic field strength.)

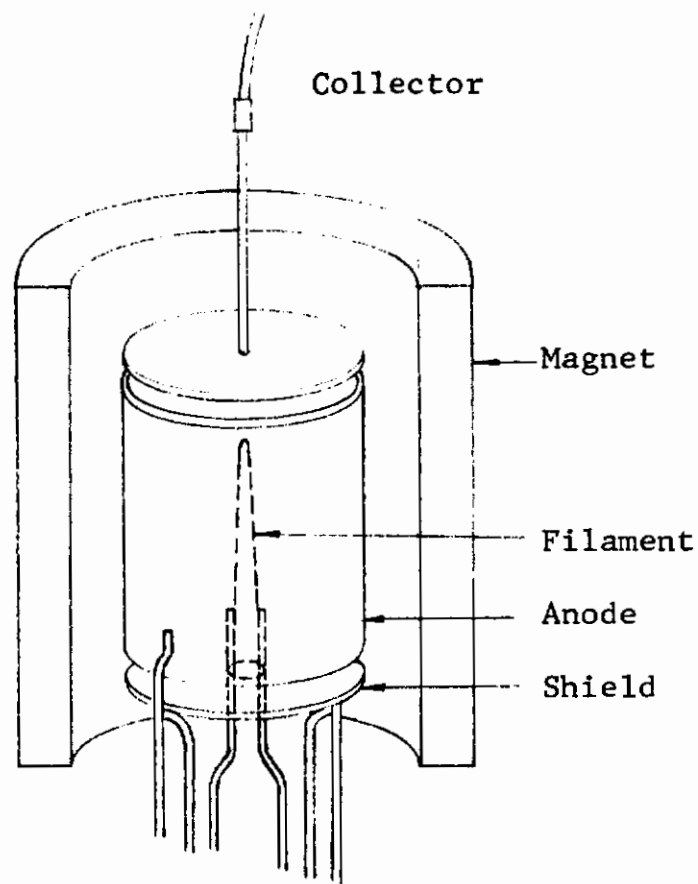

FIG. 17 LAFFERTY HOT FILAMENT MAGNETRON GAUGE

3. References

Hutson, A. R., Report on Physical Electronics Conference M.I.T., (1951) p. 102.

Lafferty, J. M., 1960 Vac. Symp. Trans. p. 97, Pergamon Press, Oxford, (1961); 1961 Vac. Symp. Trans., p. 460, Pergamon Press, Oxford, (1962); 1962 Vac. Symp. Trans., p. 438, Pergamon Press, Oxford, (1963); R.S.I. 34, 467 (1963).

F. ALPHATRON[®] GAUGE

1. Principle of Operation

The Alphasatron[®] gauge is a special type of ion gauge employing alpha particles as the ionizing agent. Radium in equilibrium with its daughter products produces a very constant alpha particle flux over a period of years. A sealed radium foil source of 200 micrograms is used in an ion chamber. (Other ionizing sources have been used - tritium, polonium, etc.) Because the alpha particle flux and the chamber dimensions are constant, the ion current is a linear function of the pressure. The gauge covers a pressure range from atmosphere to the minimum detectable limit of 10^{-5} torr with an accuracy of 2% of full scale. Full scale readings are available, by switching for each decade down to 10^{-3} torr.

The gauge has a number of distinct advantages. It covers a very wide range with good accuracy. It is linear over the entire range, and has no hot filament to burn out. On a clean vacuum system the stability is very good over long periods of time; however, high concentrations of condensable vapors which deposit on the source will reduce the alpha particle flux and reduce the sensitivity. The Alphasatron[®] is sensitive to composition of the gas depending on the ionization cross section of the gas for alpha particles.

2. Errors

Many of the errors exhibited by the Alphasatron[®] are common to all ion gauges and discussed in the general ion gauge section.

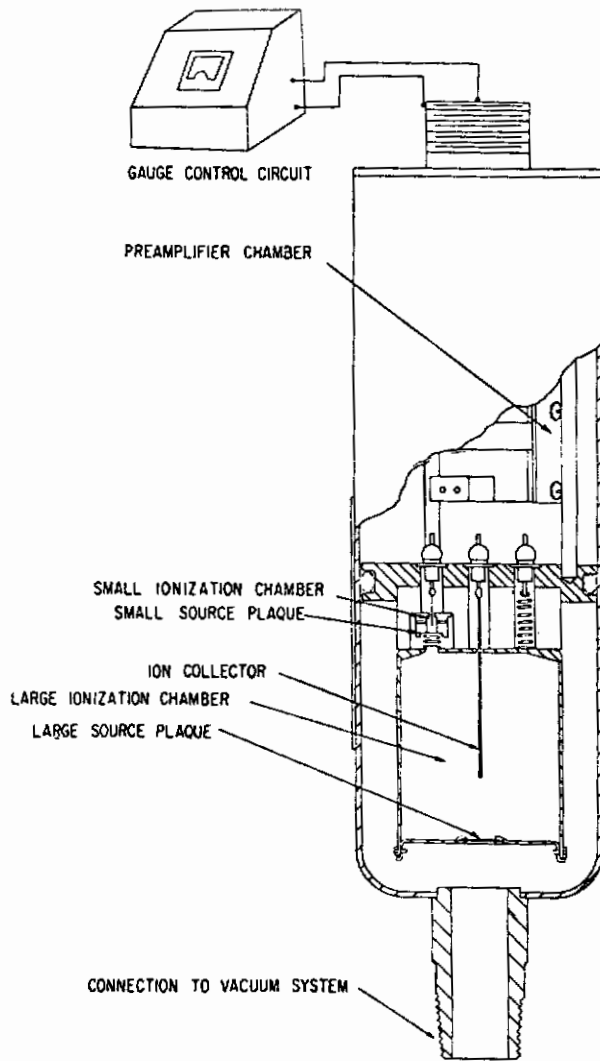

FIG. 18 SCHEMATIC SKETCH OF THE ALPHATRON IONIZATION GAUGE, WHICH USES A RADIOACTIVE SOURCE (DOWING AND MELLEN)

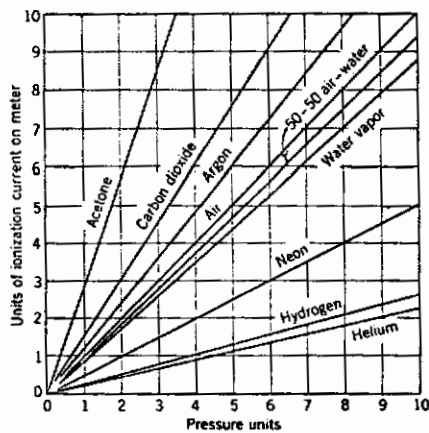

FIG. 19 RELATIVE RESPONSES OF ALPHATRON GAUGE TO VARIOUS GASES

3. Fundamental Errors

The basic requirements are: a constant flux of alpha particles, a fixed average path length, a constant average energy, all of the ions formed must be collected, and an accurate and stable means for measuring the ion current.

Radium in equilibrium with its daughter products gives a very stable flux of alpha particles for ten years or more. This flux will change if certain precautions are not taken. Any film of condensable vapors on the source will reduce the flux and will change the average energy. This is usually easily cleaned off to restore the calibration. The source is sealed with a thin metal film to retain the radon. If the gauge is used on a system with mercury pumps or gauges, the film will amalgamate with the mercury. This will release the radon and the radium will no longer be in equilibrium and loss of alpha flux will result.

If the gauge is to maintain linearity, all of the ions must be collected. At high pressure the number of ions becomes very large so that the probability increases that an ion will recombine with an electron before it reaches the ion collector. The commercial instrument includes two ion chambers. The small chamber is automatically selected by the range switch at high pressures so that recombination does not occur under normal circumstances. However, if the gas being measured has a very high ionization cross section resulting in a much larger number of ions at a given pressure, the 10 torr and 1000 torr ranges may become non-linear due to recombination.

The errors due to gas composition are discussed in the general section on ion gauges.

4. Errors Due to the Vacuum Environment

Most of the vacuum errors are discussed in the general section on vacuum gauges. The problem of outgassing is a little different because no thermal change takes place when operating the gauge and no means is provided for special outgassing techniques. If the gauge is dirty, the gauge may take a long time to pump out. Heating the gauge will speed up the process but care must be taken not to melt the solder

Contrails

connections inside. It is far better to remove the gauge and clean with acetone and alcohol. In no event should the ion chamber be opened by persons not familiar with the handling of radium.

5. Determination of Errors

Because the Alphasatron[®] gauge will read atmospheric pressure, this is an easily determined check point. If the reading checks with a good barometer, the electronic circuits are probably in good order and the surface of the radium is clean. If the reading is low the probability is good that all of the ranges will read low due to loss in gain in the amplifier or a film of oil on the radium foil.

6. References

J. R. Dowing and Glenn Mellen, R.S.I. 17, 218 (1946).

G. L. Mellen - Electronics 19, 142 (1946).

J. R. Roehrig, Report on 13th Annual Conference on Physical Electronics, M.I.T. 1953.

C. B. Sibley and J. R. Roehrig, Electronics 26, (1953).

J. R. Roehrig, Report on 12th Annual Conference on Physical Electronics, M.I.T., 1952.

R. H. Vacca, Transactions of the Third National Symposium on Vacuum Technology, 1956 (1957).

G. F. Vanderschmidt, J. R. Roehrig, and J. C. Simons, Jr., Paper Presented at the Nuclear Engineering and Science Conference, March 17-21, Chicago 1958.

J. R. Roehrig and G. F. Vanderschmidt, Transactions of the Sixth National Symposium on Vacuum Technology, 1959, (1960).

G. F. Vanderschmidt and J. C. Simons, Jr., Advances in Vacuum Science and Technology, 1, 305, (1960).

J. Moreau, Le Vide, 17, 222, (1962).

Contrails

D. Blanc and R. Dagnac, *Le Vide* 18, 322, (1963).

N. W. Spencer and R. L. Boggess, *ARS Journal* 29, 68, (1959).

G. PENNING (PHILLIPS) GAUGE

1. Principle of Operation

The Penning Gauge is an ion gauge which utilizes cold cathode electron emission and a magnetic field for increasing the path length of the electrons. The cold cathode source depends on the ejection of electrons when the cathode is bombarded with high energy ions. The electrons are then accelerated by the high voltage. The magnetic field constrains the electrons to a long helical path between the cathode and anode. The electrons formed by ionization also are a part of the total electron stream and will produce additional ions. It is this avalanche effect which produces the high sensitivity. Because the ion current and electron current form the total current between the two electrodes, the current is a non-linear function of pressure. The total current is large enough, however, to be measured with an ordinary microammeter. This of course makes the gauge fairly inexpensive and coupled with the fact that there is no hot filament to burn out, makes the gauge very attractive. It will read pressures between 10^{-7} and 10^{-3} torr, a very commercially useful range. Except for a few specialized applications, however, it has not had a high degree of popularity.

There are two major drawbacks which limit its utility. At very low pressures the gas discharge does not start or if started at higher pressure will not continue operating. In addition, the high energy electrons sputter material from the anode. This material will cover the insulators causing erroneous readings if the gauge is not cleaned regularly. In many cases the gas discharge is unstable due to oscillation causing unpredictable jumps in the current pressure relationship. The instabilities are improved by using a cylinder in place of the ring cathode. The ionic pumping speed of this type of gauge is very high, 10 to 100 times higher than a hot filament gauge. It is therefore necessary to use large tubulation to connect the gauge to the system.

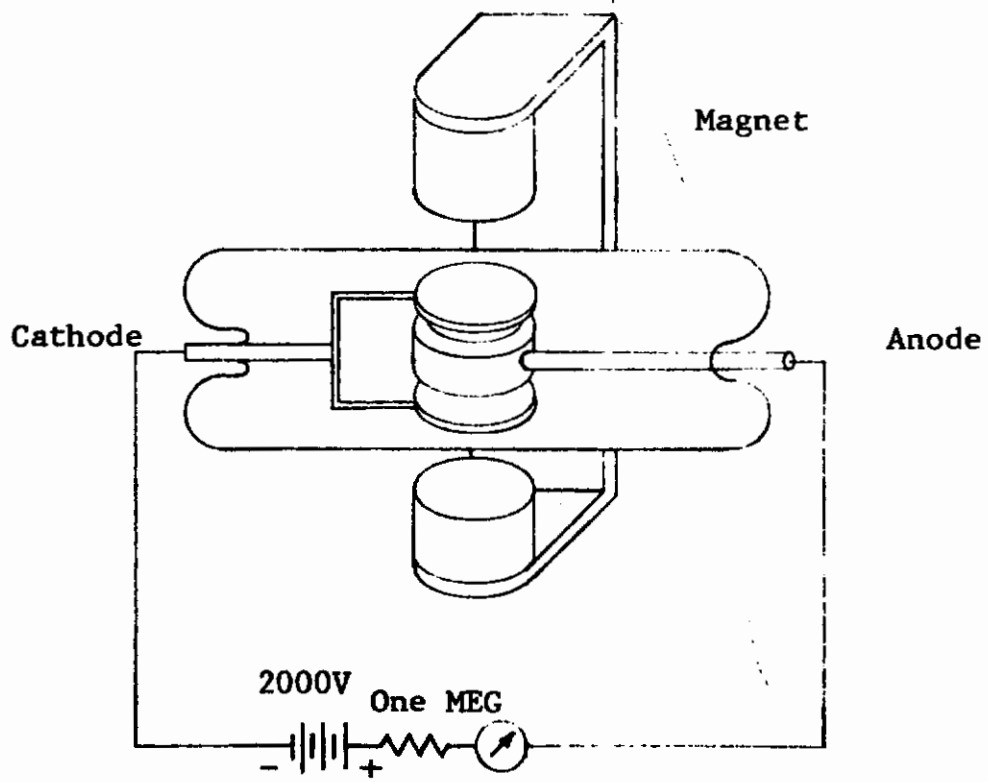

FIG. 20 PENNING GAUGE

Contrails

For these reasons the accuracy is generally poor and the gauge should be used as an order of magnitude indicator only.

A new type of Penning Gauge recently announced may overcome some of the problems indicated above. A filament is included to trigger the discharge at very low pressures. This does not require continuous operation of the filament but just a momentary flash. It is claimed that the gauge is linear from 10^{-4} to 10^{-14} torr although the last three decades appear to be an extrapolation. The advertised pumping speed -0.1 liter per second, is very low in view of the high sensitivity, - 1/2 amp per torr. These characteristics are a big improvement over the usual Penning Gauge.

2. Errors

The sensitivity of the gauge is a function of voltage, magnetic field intensity, and the geometric configuration of the elements. Any changes in these parameters will change the calibration. While in general, small changes in any of the parameters will cause only small changes in the sensitivity, if the change is accompanied by a change in the oscillating mode of the discharge, a large change in sensitivity may occur.

Because the gauge is sensitive to geometry, the elements must be rugged. Even under these conditions, calibration shifts may arise when the gauge is disassembled for cleaning.

Reference should be made to the general section on vacuum gauges for errors in the Penning Gauge common to all gauges.

H. COLD CATHODE MAGNETRON GAUGE (Redhead Gauge)

1. Principle of Operation

The Redhead gauge is a cold cathode discharge ion gauge (Penning Gauge) in the configuration of a magnetron diode operating above cut-off. In this design the field emission and ion collection are separated so that the current to the ion collection cathode is linear with pressure, or in some cases, a power function of pressure. Two somewhat different designs are in use, one a normal magnetron and the other an

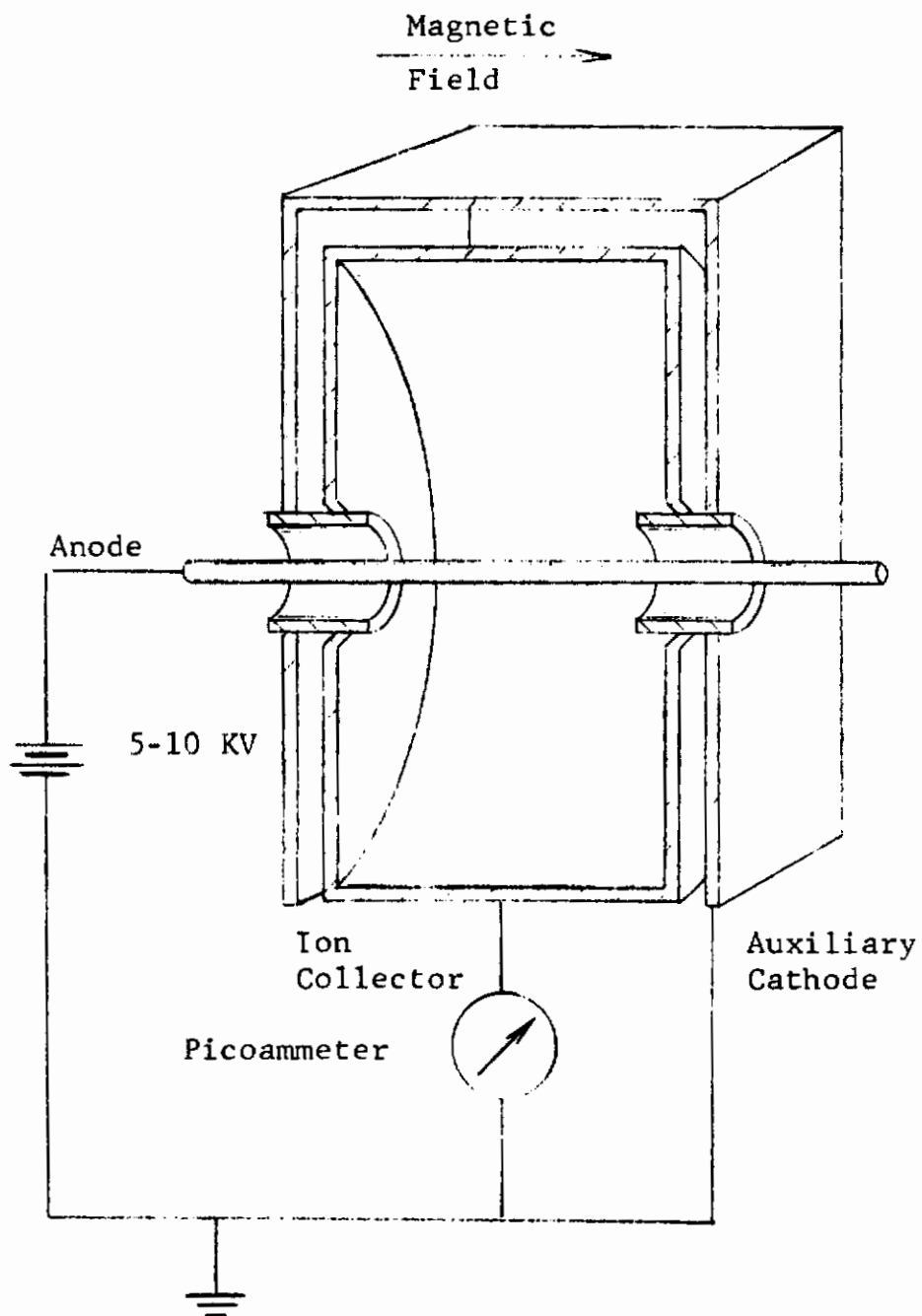

FIG. 21 REDHEAD INVERTED MAGNETRON GAUGE

Contrails

inverted magnetron -- the anode being a rod on the axis of the cathode cylinder. The two designs are shown in the diagram. The auxiliary cathode is the field emission cathode, and shields the ion cathode so that the field emission is not measured by the electrometer. The electrons are trapped radially by the cathode and plates and axially by the magnetic field. The only way the electrons can escape is through collisions with gas molecules driving them toward the anode. The gauges operate with 5-6KV on the anode and a 2 kilogauss magnet for the magnetron gauge and 1 Kg for the inverted magnetron. Under these operating conditions, no trouble is experienced in starting the discharge even at pressures as low as 10^{-14} torr.

The ion current vs. pressure relationship in the magnetron gauge is a power function,

$$i_+ = cp^{1.15} .$$

This gives a log-log plot as a straight line but it is not at a slope of 45°. The inverted magnetron is linear down to a pressure of 5×10^{-10} and then breaks sharply to a power function,

$$i_+ = cp^{1.17} .$$

There is some evidence that at 10^{-12} torr there is another break to another power function. The sensitivity of both gauges is 4.5 amps per torr or approximately 45 times the sensitivity of a standard Bayard-Alpert. Its pumping speed is also much greater than the Bayard-Alpert - 5 liters/sec.

Both gauges are operated from 10^{-4} down to at least 10^{-14} torr. The limit appears to be only the limit of current measurement.

Outgassing the gauge does not seem to be a problem probably because there are no thermal changes in operation. If the gauge is contaminated with pump oil, it does need to be baked out if low pressures are to be achieved. If the gauge is reasonably clean it will clean itself up in a reasonably short time. In order to keep it clean, the gauge is generally left running continuously. Under some conditions of contamination the noise level will be high due to much

higher than normal field emission. This can be cleaned by sparking with a tesla coil.

Although the gauge is not very sensitive to changes in the magnetic field strength at the values recommended, very low values will change the operating characteristics. Similarly, the anode voltage can be varied with little change in sensitivity between 4 and 6 kilovolts. However, good regulation of the high voltage is necessary since noise peaks will be transmitted to the electrometer circuit by capacity coupling in the gauge.

2. Errors

Most of the errors discussed in the general ion gauge section apply to the Redhead gauge. The requirements for large tubulation to the system apply particularly to the cold cathode gauges because of the high pumping speed. The magnet field strength should be measured to determine if it is close to the recommended value. This is particularly necessary if the magnet has been disassembled or dropped. Calibration of the gauge at very low pressures is not easily accomplished, so that an extrapolation of the curve at lower pressures is used. If unknown breaks in the curve occur at higher pressures, the errors will be very large.

3. References

Redhead, P. A., Report on Physical Electronics Conference, M.I.T., p. 170 (1957); same (1958), p. 135; Can. J. Phys. 37, 1260 (1959); Advances in Vac. Sci. and Tech. Vol. 1, p. 410, Pergamon Press, Oxford (1960).

IX. VACUUM GAUGE CALIBRATION

In any calibration there are inherent errors encountered in tracing the measured parameters back to measurable physical standards. In the calibration of vacuum gauges, the problem is even more complex since no physical standard exists at very low pressures. In the higher pressure ranges direct comparison with a primary standard is possible. At lower pressures reference to the primary standard can only be made by transfer to a secondary standard and extrapolation of this calibration to the range of interest. It is therefore necessary to experimentally establish the probable accuracy with which the standard is transferred to the secondary standard and to experimentally establish the self-consistency of the method of extrapolation. In recent years new methods for extending the range of usefulness of the present primary standards have been developed. These methods employ a pressure reduction system which depends only on the measurable parameters of the system and, therefore, can define a known pressure to which the test gauge may be exposed. Although these methods have not yet been accepted as standards, they are the best available at the present time. Work remains to be done to establish the accuracy and reliability of these standards, together with the gauges that are calibrated by them.

In the following sections a number of calibration methods will be discussed which cover the vacuum pressure range down to 10^{-9} torr. This is the limit for commercially available equipment at the present time. Calibration at even lower pressures can be achieved by extension of the multiple chamber method.

A. CALIBRATION IN THE RANGE ATMOSPHERE TO 10 TORR

In this range, there is little question as to the primary standard. The barometric mercury manometer has been accepted and quality instruments are commercially available. Accuracy of $\pm .01$ can be obtained.

The calibration method is by direct comparison with the primary standard. This requires only a small mechanical pump, a few valves and a supply of dry gas for backfilling. The valves and connections must be leak tight so that stable

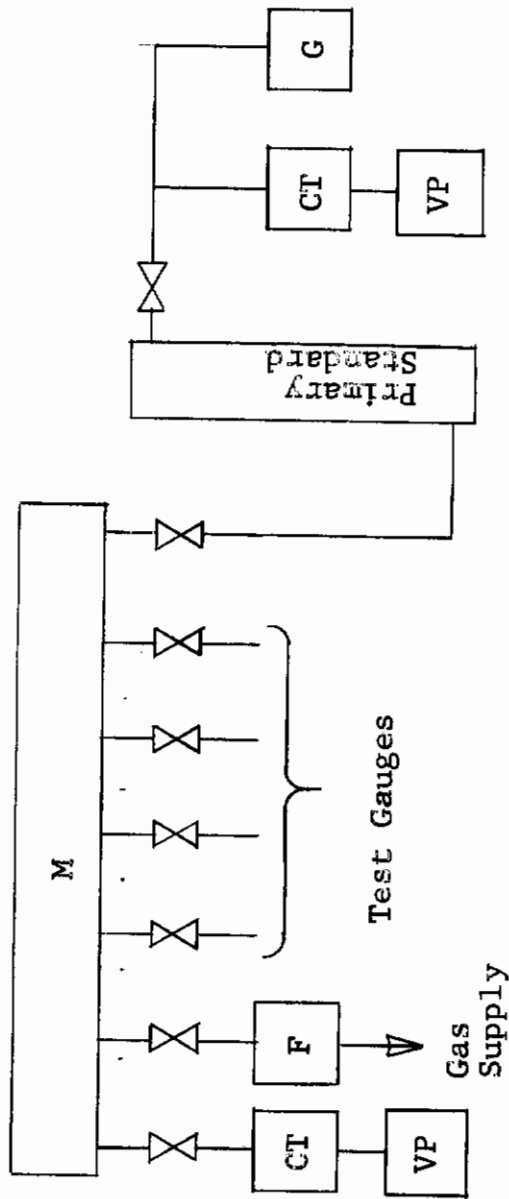

Fig. 22 - Calibration System Atmosphere to 10 torr

M - the manifold; CT - cold trap; VP - vacuum pump;

G - gauge for monitoring the reference pressure;

F - drying filter.

Contrails

static conditions can be obtained. The choice of gas is not critical. Dry air must be used but a gas such as nitrogen is preferable in order to prevent oxidation of the mercury surface. The system shown in the diagram includes a manifold so that several test gauges can be calibrated at the same time.

An initial pumpdown of the test gauges to the blank-off of the manifold pumping system will determine if there are any leaks or serious outgassing. The leak rate must be small compared to the accuracy required. It may take some pumping time before the outgassing rate is small. After the system has reached the blank-off pressure, the zero points of all the gauges can be determined. The system is then backfilled with the dry gas to obtain steps of increasing pressure for calibration of the test gauges by comparison with the standard. After each change in pressure, the system must be allowed to come to equilibrium before readings are made. Several successive readings a few minutes apart will establish when equilibrium has been reached.

An alternative to this purely static method is to use a device for maintaining a constant pressure in the manifold. Such a device is the barostat described in NBS Monograph No. 8, entitled, "Mercury Barometers and Manometers." The device must maintain the pressure constant well within the limits of accuracy required.

A thorough discussion of the standard manometer, its errors and calibration is included in this Monograph No. 8.

B. CALIBRATION IN THE RANGE 10 TORR TO 10^{-5} TORR

Calibration of gauges in this range is also a direct comparison procedure but with different primary standards. In this range the more specialized manometers must be used for the comparison standard -- the micrometer manometer (10 torr to 0.1 torr), the interferometer manometer (10^{-1} to 10^{-3} torr), and the McLeod Gauge (10 to 10^{-5} torr). The micrometer manometer and McLeod Gauge are commercially available. The choice between them is a compromise - the micrometer manometer is more accurate at the upper end of its range and a properly designed McLeod is more accurate at the lower end. Two McLeod gauges with different compression

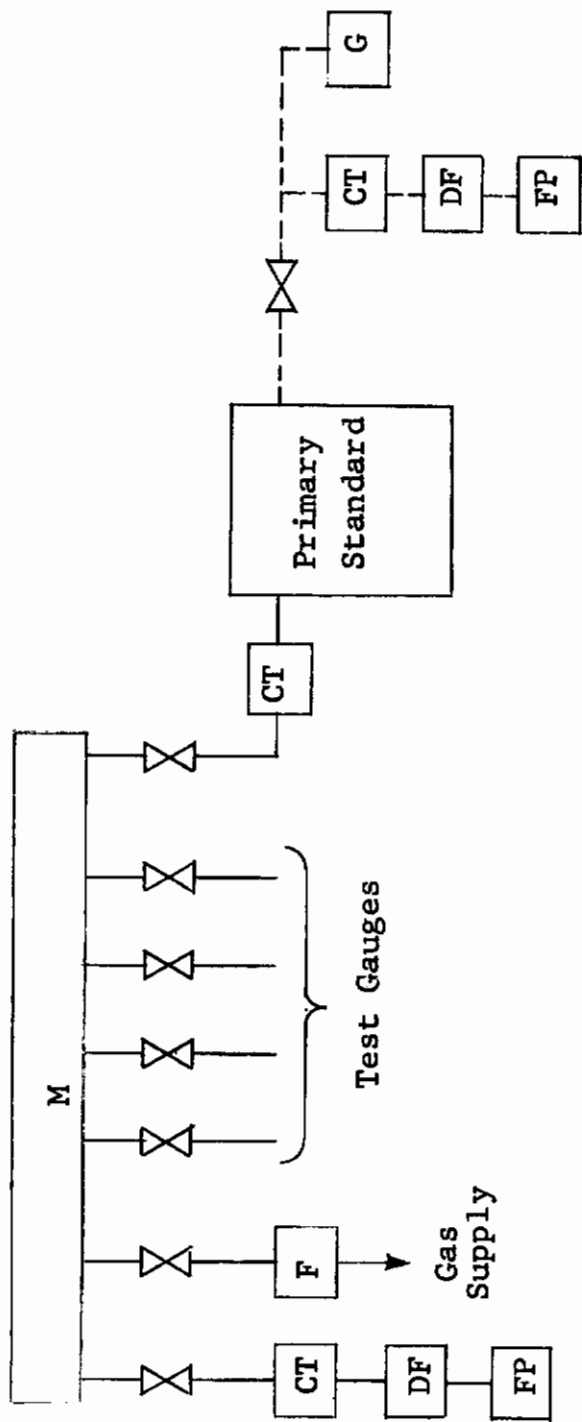

Fig. 23 - Calibration System 10 torr to 10^{-4} torr

M - manifold; CT - cold trap; DF - diffusion pump;
FP - forepump; F - filter; G - gauge for monitoring the reference
pressure. Dotted section required
for micrometer manometer only.

Contrails

ratios or a multiple range McLeod are required to cover the whole range.

The calibration method is similar to the higher range previously discussed. The requirements for the system are much more stringent as to leaks and outgassing. The system must be pumped with a diffusion pump in order to obtain the low "zero" pressure required. The pressure change in the static system must be less than the accuracy required over the period for making a measurement. The reference zero system for the manometer must also provide a much lower pressure. The McLeod Gauge does not require a reference zero. An additional cold trap will also be necessary between the standard and the system to keep mercury vapor (or oil vapor) from the test gauges and manifold.

The procedure outlined for the higher pressure range is followed for this range also. The time required for equilibrium to be reached will be somewhat longer at the lower pressures particularly with the McLeod Gauge. Several successive readings of each pressure should be made with the McLeod in order to average the random errors.

1. References

S. Schuhmann, 1962 Vacuum Symposium Trans. p. 463, Pergamon Press, Oxford (1963).

W. B. Nottingham and F. L. Torney, Jr., 1960 Vacuum Symp. Trans., p. 117, Pergamon Press, Oxford (1961).

G. C. Fryburg and J. H. Simons, R.S.I. 20, 541 (1949).

A. P. Flanick and J. E. Ainsworth, R.S.I. 32, 408 (1961).

C. CALIBRATION BELOW 10^{-3} TORR

The calibration of vacuum gauges below 10^{-3} torr is not an easy task. The only standards available are the McLeod gauge and the Knudsen gauge. A good McLeod gauge₅ will operate with reasonable accuracy ($\pm 5\%$) down to 10^{-5} torr, but at lower pressures, the errors associated with the gauge reduce the confidence level to such an extent that it can no longer be considered a standard. The Knudsen gauge

Contrails

has not seen wide use due to the construction problems and the question of accommodation coefficient. (See the previous sections on these gauges.) Because of this situation, the common practice is to extrapolate the calibration at higher pressures to the readings at lower pressures (primarily ion gauges). While this practice has been reasonably satisfactory for practical purposes, the errors of course can become very large orders of magnitude.

In 1910, Knudsen described a method for producing a low known pressure for the calibration of his radiometer gauge. If a known volume of gas at a known high pressure is expanded into a much larger volume, the new pressure can be determined by Boyle's law.

$$pV = p^1V^1,$$

assuming a constant temperature.

Successive expansion of small aliquots of the expanded gas will permit much lower known pressures to be obtained. Although a number of workers have used the method with some success, the question of the errors due to adsorption and desorption on the walls of the vessels is still unresolved. Schuman at the Bureau of Standards has calibrated an ion gauge down to 2×10^{-7} torr and believes the over-all accuracy to be + 10%. The linear calibration curve would seem to indicate that he was not troubled by adsorption effects within these limits. One major problem with any static system such as this is the pumping of ion gauges. If any of the expanded gas is lost through pumping, the new pressure will not be as calculated. The problem can be reduced by operating the gauge only intermittently and with very low grid currents.

Within the past few years, two new methods have been proposed for the calibration of gauges at lower pressures. Both of these systems are dynamic systems in which calibrated orifices are used to provide a known lower pressure from a gas flow measurement or a higher pressure measurement. The basic building block is shown in the diagram.

Contrails

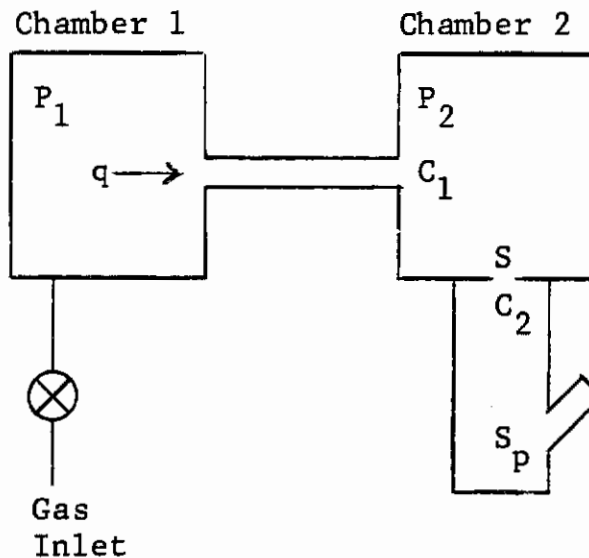

The pressure, P_2 , in Chamber 2 can be determined in two ways. The pumping speed out of the chamber is determined by the conductance C_2 and the speed of the pump S_p

$$S = \frac{C_2}{1 + \frac{C_2}{S_p}} .$$

If the input flow of gas q is measured, then

$$P_2 = \frac{q}{S} .$$

In this case, C_1 can be a variable leak to vary the pressure P_2 .

If C_1 is a fixed calibrated conductance, the pressure P_2 can be determined by measuring the pressure P_1 .

$$\frac{P_1}{P_2} = \frac{C_1 + \frac{C_2}{1 + \frac{C_2}{S_p}}}{C_1}$$

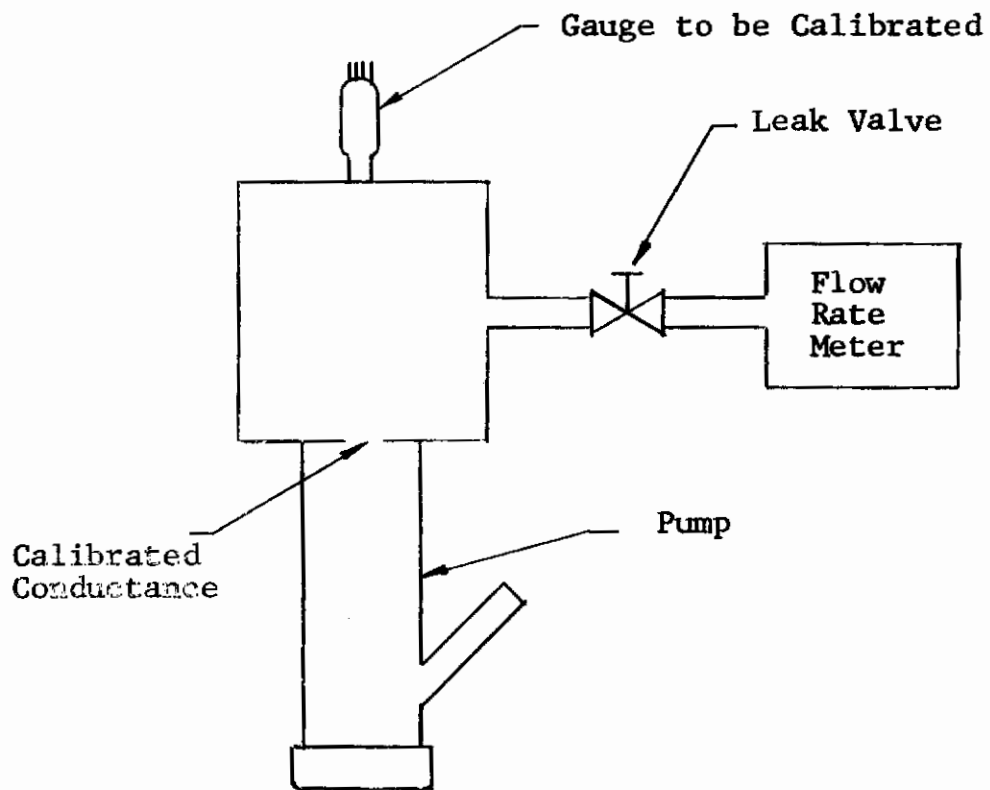

Fig. 24 - Orifice-type Calibration System Using Flow Meter

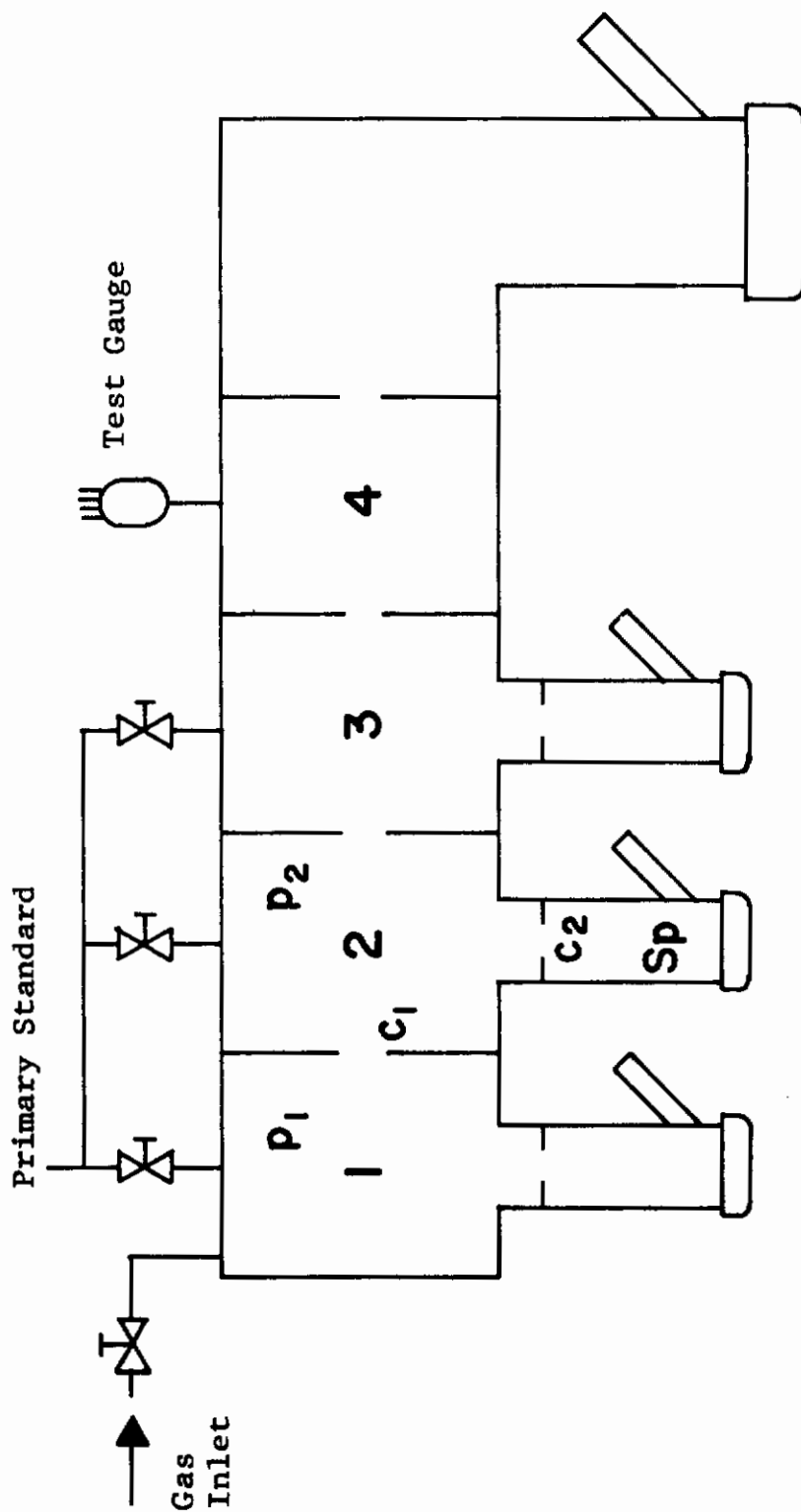

FIG. 25 MULTIPLE STAGE, CONDUCTANCE LIMITED PRESSURE REDUCTION CALIBRATION SYSTEM

Contrails

If the pumping speed S_p is large compared to C_2 , variations in pumping speed will have little effect on the conductance.

Since the conductances C_1 and C_2 can be calculated from their dimensions (assuming molecular flow) and flow or pressure up stream can be measured accurately, the downstream pressure P_2 can be predicted very accurately. Gauges connected to the second chamber can then be calibrated. The basic assumption in the above equation is that there are no other gas sources or sinks in Chamber 2. Outgassing and leaks will cause errors. However, the source of error can be determined easily. With the gas inlet closed, the blank-off pressure can be measured and the error will be that proportion of the predicted pressure when the gas is flowing. If the blank-off is 1×10^{-9} torr this will be 1% when the predicted pressure is 1×10^{-7} . The problem with gas sinks is not quite as easily resolved. Because most of the gauges used at these low pressures also act as pumps, the pressure in the chamber is affected by their pumping action. For this reason C_2 must be large compared to the pumping speed of any gauge operating on the chamber. For a 1% error, the conductance of C_2 corrected for S_p must be 100 times the pumping speed of the gauge or gauges.

The single stage pressure reduction is limited in each method. In the gas flow method, the flow measuring equipment available limits the pressure in Chamber 2 to about 5×10^{-7} torr. At lower pressures the gas flow is so small it cannot be measured accurately. For the pressure measurement system, the accuracy of the McLeod gauge at low pressures and the accuracy in measuring the dimensions of C_1 limit the P_2 pressure to about the same value. The method can be extended by the addition of multiple stages with known conductances between stages. Systems of this kind have been built to calibrate gauges to 10^{-9} torr and below. (See Figure 25)

The single stage pressure reduction can be used with very small conductance C , for lower pressures by measuring the conductance. However, the accuracy of this measurement is questionable.

One major advantage accrues from the use of two orifices. The conductance of an orifice is composition dependent so

Contrails

that with a single orifice the pressure P_2 depends on the gas specie. With two orifices, the total flow changes but the pressure ratio $\frac{P_1}{P_2}$ does not change. With this method, any single gas or combination of gases may be used without recalculating the conductances.

Equipment using both of these methods is now commercially available with claimed accuracy of $\pm 10\%$. With experience this figure should be improved.

1. References

W. H. Hayward and R. L. Jepsen, 1962 Vacuum Symposium Transactions, Pergamon Press, Oxford (1963).

N. A. Florescu, 1959 Vacuum Symposium Transactions, 75-81, Pergamon Press, Oxford (1960).

N. A. Florescu, 1961 Vacuum Symposium Transactions, 504-510, Pergamon Press, Oxford (1962).

J. R. Roehrig and J. C. Simons, Jr., 1961 Vacuum Symposium Transactions, 511-518, Pergamon Press, Oxford (1962).

C. E. Normand, 1961 Vacuum Symposium Transactions, 534-543, Pergamon Press, Oxford (1962).

J. C. Simons, Jr., 1963 Vacuum Symposium Transactions, to be published.

J. C. Simons, Jr. and J. R. Roehrig, Final Report - NASA Contract NAS5-14.

W. S. Kreisman, 1960 Vacuum Symposium Transactions, 75-79, Pergamon Press, Oxford (1961).

S. Naiditch, Report on 13th Annual Physical Electronics Conference, MIT 1953.

C. L. Owens, AEDC-TDR-62-139, August 1962.

C. Meinke and G. Reich, Vakuu-Technik 11, 3 (1962).

Contrails

M. Goto, Advances in Vac. Science and Tech. Vol. I, p. 226, Pergamon Press, Oxford (1960).

S. Schuhmann, 1962 Vacuum Symposium Transactions, p. 463, Pergamon Press, Oxford (1963).

W. B. Nottingham and F. L. Torney, Jr., 1960 Vacuum Symp. Trans., p. 117, Pergamon Press, Oxford (1961).

G. C. Fryburg and J. H. Simons, RSI 20, 541 (1949).

D. RECOMMENDED CALIBRATION METHOD FOR 1 TORR TO 10^{-9} TORR AND LOWER

The main body of this report has been a discussion of the many commercially available vacuum gauges and the methods for their calibration. A further requirement under the contract is the recommendation for a standard calibration method in the pressure range 1 torr to 10^{-9} and lower. The several methods available have been investigated and discussed in the previous section. From the viewpoint of covering this complete range with the same equipment and procedure, and indeed the only equipment available, the choice is the multiple orifice, multiple chamber method. Although it has been indicated in the previous discussion, this method, with a dual range McLeod gauge, will cover the whole range providing direct calibration down to 10^{-4} torr and pressure reference calibration as low as the state-of-the-art permits. The present limit is 10^{-9} torr (limited by a 10^{-11} torr ultimate system pressure), but additional stages pumped to lower pressures, as the art progresses, will provide even lower limits.

A number of outstanding advantages can be listed for this choice.

1. The McLeod gauge is a recognized standard for low pressure measurement.
2. The calibration can be carried out with any non-condensable gas or mixture of gases.
3. Because of the building block nature of the system, a calibration facility can be modestly begun and then additions made to accommodate lower pressures as required.

Contrails

In order to empirically test the theoretical pressure ratios, a program was carried out in which a group of standardized ion gauges were used to determine the pressure ratios. The six different ratios available on a four-chamber system were compared in this manner and the ion gauge data agreed, within the accuracy of the method, with the calculated pressure ratios. The data obtained in calibrating a number of ion gauges also indicate that the pressure ratios are as calculated because there are no discontinuities in the calibration curves when different combinations of orifices are used (see Figures 26 and 27).

The system itself is very versatile. Gauges may be mounted on any of the four chambers to obtain different pressure ranges as required. Direct comparison calibration is available to the upper limit of the McLeod gauge or other primary standard.

The multiple orifice, multiple chamber system is recommended as the standard method for calibration and the procedure has been outlined in the proposed MIL-STD accompanying this report.

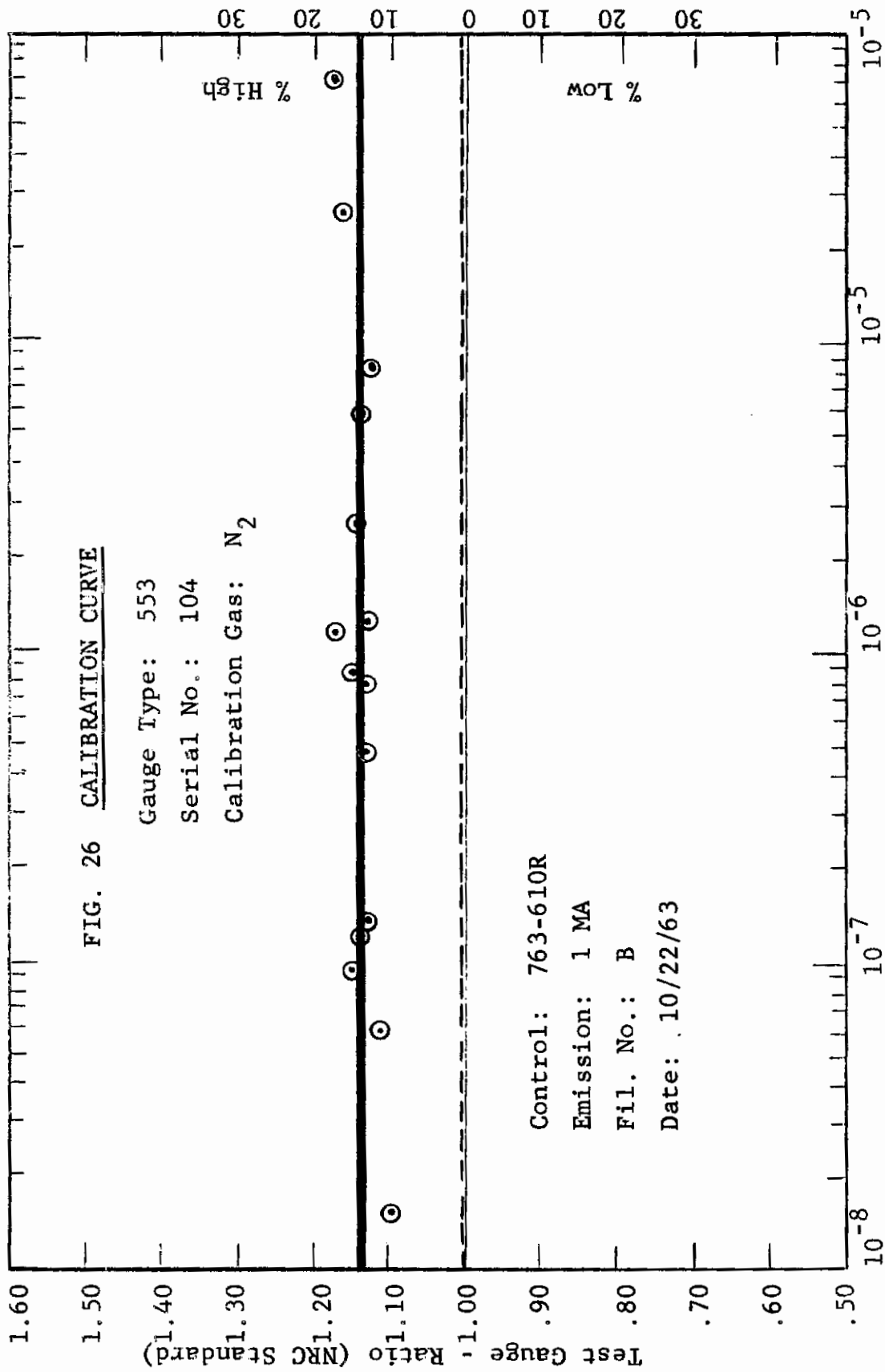

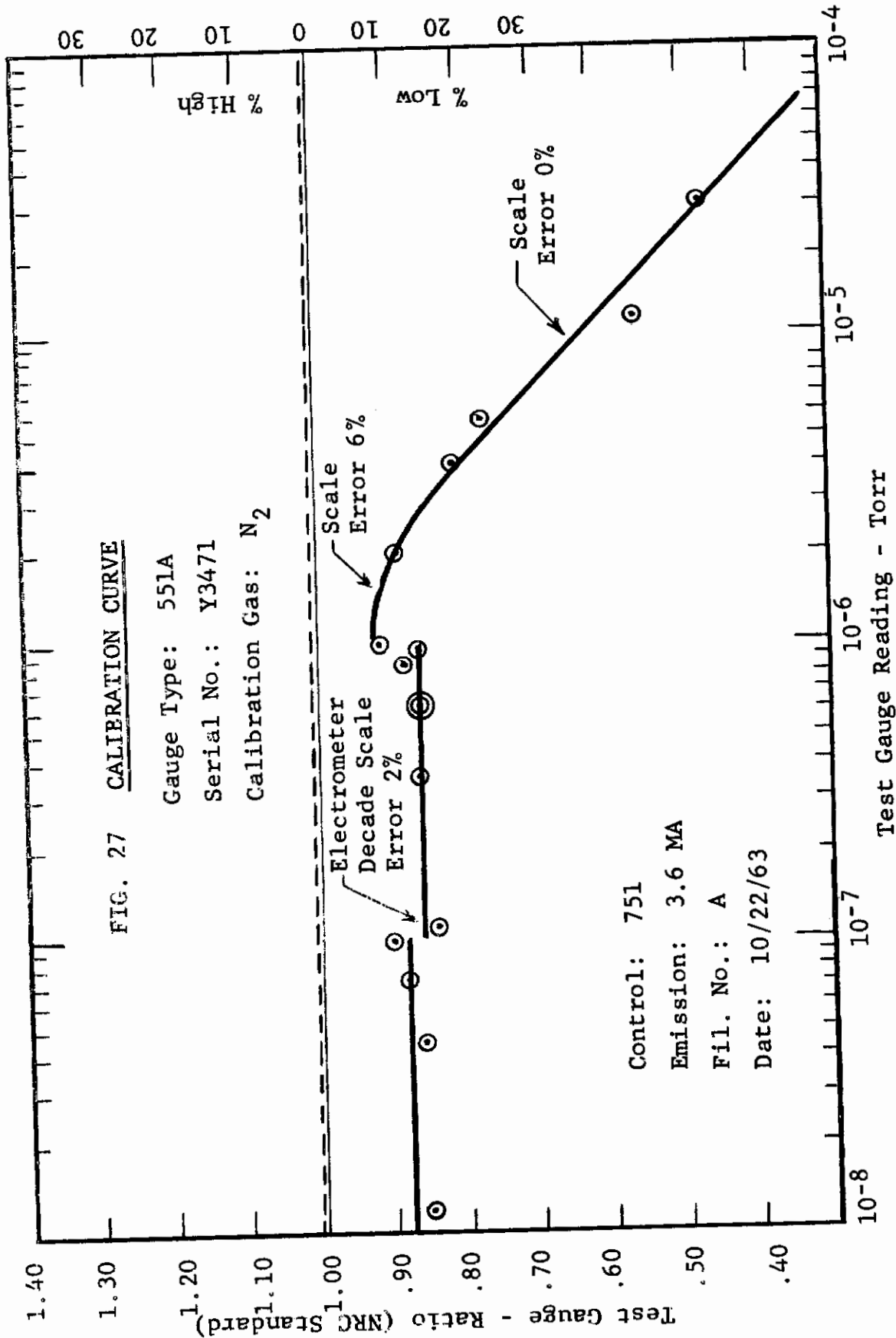

Contrails