

**EXPOSURES OF BIOLOGICAL SYSTEMS TO
INORGANIC FLUORIDE OXIDIZING AGENTS
VOLUME II. FLUORIDE ANALYSIS BY CHEMICAL METHODS**

*DONALD J. REED, PhD
FRANK N. DOST, DVM
CHIH H. WANG, PhD*

Distribution of This Document Is Unlimited.

FOREWORD

This study was initiated by the Biomedical Laboratory of the Aerospace Medical Research Laboratories, Aerospace Medical Division, Wright-Patterson Air Force Base, Ohio. The research was performed in support of Project No. 6302, "Toxic Hazards of Propellants and Materials," Task No. 630202, "Pharmacology-Biochemistry," under Contract No. AF 33(615)-1799, with the Radiation Center, Oregon State University, Corvallis, Oregon. Dr. C. H. Wang was the principal investigator for Oregon State University and Dr. K. C. Back was contract monitor for the Toxic Hazards Branch. Research was initiated 1 July 1964 and completed 30 June 1965.

The technical assistance of Mr. Royal Barbour has been very valuable to the conduct of this work.

This technical report has been reviewed and is approved.

WAYNE H. McCANDLESS
Technical Director
Biomedical Laboratory
Aerospace Medical Research Laboratories

ABSTRACT

Methods are described for assaying the fluoride content of ashed samples of plant and animal tissues. Using the Hall method, submicrogram quantities of fluoride were measured and a new procedure was devised to measure fluoride in a 1 to 8 microgram range. Modification of the Weinstein procedure, in which an AutoAnalyzer is used, permitted rapid and semiautomated analysis of samples containing 2.5 to 100 micrograms of fluoride.

Contrails

SECTION I

INTRODUCTION

The determination of the fluoride content of tissues from organisms exposed to inorganic fluorides aids in establishing mechanisms of toxicity and chemical damage by these agents. Methods for the rapid analysis of fluoride ion are needed in the determination of the concentrations of inorganic fluorides in air atmospheres since analysis of the atmospheres prior to exposure of biological materials to these atmospheres is very advantageous. In addition, instrumental monitoring techniques, such as infrared spectroscopy and gas chromatography, depend, in part, on an accurate sampling and chemical analysis of the inorganic fluoride-air atmospheres. Methods for fluoride analysis were numerous but many of these methods are slow or unsuitable for measurement of microgram and nanogram quantities of inorganic fluorides.

The variability of normal fluoride levels in plant tissues and soft tissues of animals appears to be due in part both to the relatively low concentration of this element in such tissues under normal conditions and to the considerable difficulty of quantitative recovery of fluoride during ashing and subsequent analytical procedures. Thus, the preparation of biological samples for fluoride analysis requires special techniques such as ashing and alkali fusion (ref. 1), sodium peroxide combustion (ref. 2), oxygen combustion (ref. 3, 4, 5, 6) or perchloric acid treatment (ref. 7). After a suitable treatment procedure, the fluoride-containing sample must be processed to separate fluoride from other ions which interfere with subsequent colorimetric or titration methods. The separation is most commonly accomplished by distillation from perchloric acid using the classical Willard-Winter procedure (ref. 8) or some modification of this method (ref. 9). Other distillation procedures (ref. 10, 11), microdiffusion (ref. 7, 12, 13, 14, 15), and ion-exchange chromatography (ref. 16, 17) have also been employed.

The method described by Hall (ref. 14) for the accurate determination of submicrogram amounts of fluoride involves a direct color reaction of fluoride ion with alizarin complexone. The method was shown to be suitable for the determination of fluoride in biological materials. The range of concentration of fluoride ion needed for reproducibility of analysis was 0.1 to 1.0 $\mu\text{g}/\text{sample}$. This method, however, is not a rapid one since a diffusion time of 24 hours is necessary to

separate the fluoride ion from other salts prior to analysis. During the course of our work, we have utilized a combination of the Hall diffusion procedure and the alizarin complexone reagent of Weinstein to provide a new analysis procedure. The new method permits determination of fluoride in samples containing up to 6 μg fluoride/sample.

Weinstein et al. (ref. 18) described a rapid, semiautomated procedure for the analysis of fluoride in air and plant tissue samples. This procedure was based upon the use of the Technicon AutoAnalyzer and the lanthanum-alizarin complexone color reaction. The method is a comparatively rapid one since analytical data on ashed samples can be obtained in approximately 13 to 15 minutes. The rate of analysis is 10 samples per hour, enabling use of this method for the determination of fluoride content of air atmospheres of inorganic fluorides. We found that very reproducible results could be obtained with samples containing 2.5 to 100 μg of fluoride ion.

SECTION II

METHODS AND MATERIALS

Animals

Rats used for these experiments were male Sprague-Dawley rats obtained from Pacord Research, Inc., Portland, Oregon. The rats were maintained on Purina Laboratory Chow and fluoridated city water (1 ppm) ad libitum until the time of experiment.

Preparation of Samples for Ashing

For fluoride analysis, tissues of animals or plants were dried at approximately 60°C by infrared lamps overnight. One gm of each dried sample was placed in a nickel crucible with 1.5 ml of 1 N lithium hydroxide and 1 ml of 0.2 M magnesium succinate. The samples were again dried, the crucibles covered and fired overnight at 400°C in a muffle furnace equipped with an electronic temperature controller. This sample preparation procedure was used for the three methods of fluoride analysis described in this report.

Analysis by the Hall Method

Reagents

Contrails

The reagents used were of reagent or analytical grade. Distilled water which had been passed through an ion-exchange column, Barnstead Model DD-1, was used to prepare all reagents and to carry out the analysis.

- 1) Magnesium succinate, 0.2 M.
- 2) Lithium hydroxide, 1 N.
- 3) Alizarin complexone (3- [Di(carboxymethyl) amino-methyl] -1,2 dihydroxyanthraquinone), $5 \times 10^{-4} M^*$.
- 4) Silver perchlorate, 0.257 N, with respect to Agt, prepared by dissolving 4 gm silver sulphate in 100 ml of 70% perchloric acid.
- 5) Succinate buffer, pH 4.6, a solution of 0.4724 gm of succinic acid in 50 ml of water and sufficient 1N NaOH to adjust the pH to 4.6, then diluted to a total volume of 100 ml with water.
- 6) Lanthanum nitrate, $1 \times 10^{-3} M$.
- 7) Hydroxylamine hydrochloride, 1.0 M.
- 8) Buffered lanthanum-alizarin complexone reagent. This reagent was prepared from 30 ml of alizarin complexone, 50 ml of succinate buffer, 20 ml lanthanum nitrate solution, and 25 ml of tertiary butanol.
- 9) Extracting solvent - The solution for extraction was prepared from 3 ml of hydroxylamine hydrochloride solution and 97 ml of isobutanol.

Analysis Procedure

A weighed quantity of the ash was placed in a volumetric flask and dissolved in 1 ml of 0.5 N perchloric acid. If any undissolved ash remained, 0.1 ml of 70% perchloric acid was added and, when necessary, the solution was warmed gently. After adjusting the volume of the ash solution to a known volume, a 1 ml

* Obtained from Hopkin and Williams, Ltd., Freshwater Road, Chadwell Heath, Essex, England.

aliquot was then placed in a 30 ml polyethylene diffusion bottle as described by Hall (ref. 4). During the diffusion, hydrogen fluoride is absorbed by a paper wick covered with magnesium succinate. To prepare the wick, a 3 cm by 1.2 cm rectangular piece of Whatman 541 filter paper, which had been previously washed and dried, was impregnated with 15 μ l of 0.2 M magnesium succinate, rolled into a cylinder and fitted into a Teflon holder in the cap of the diffusion bottle. Two ml of silver perchlorate, 0.257 N, was added to the solution of ash, the cap was then screwed on tightly, and diffusion carried out at 60° C for 16 to 24 hr.

After the diffusion period, the filter paper wick was removed from the diffusion bottle and placed in a 5 ml glass-stoppered centrifuge tube containing 2 ml of lanthanum-alizarin complexone solution. The stoppered tube was then incubated at 60° C for 15 min to allow color development and then cooled to room temperature. The fluoride-lanthanum-alizarin complexone was extracted first with 1.5 ml and then twice with 1.0 ml portions of the isobutanol-hydroxylamine hydrochloride solution. After each extraction, the phases were separated by centrifugation of the successive extracts and pooled in a glass-stoppered centrifuge tube. One ml of water was added to the pooled extracts. The tube was vigorously shaken and cooled to 0° C for 30 min. The phases were again separated by centrifugation, and the isobutanol fraction containing the blue complex was brought to a volume of 4.0 ml. The optical density of each fraction was measured on a Beckman DB spectrophotometer at a wavelength of 570 m μ .

A Combined Hall-Weinstein Method for Fluoride Analysis

Reagents

- 1) Alizarin-complexone, 0.01 M, was prepared by suspending 962.5 mg of alizarin in 100 ml of water and 2 ml of ammonium hydroxide (28% NH₃) added to dissolve the alizarin. The pH of the solution was then lowered with 2 ml concentrated acetic acid and

Contrails

the solution volume brought to 250 ml with water.
The pH of the final solution was 5.3.

- 2) Lanthanum nitrate, 0.01 M.
- 3) Sodium acetate buffer, pH 4, prepared by adding 100 ml of concentrated acetic acid to 60 gm of sodium acetate $\cdot 3H_2O$ in 500 ml of water. The total volume was then adjusted to 1.0 l.
- 4) The lanthanum-alizarin complexone reagent was comprised of 200 ml of water, 200 ml of acetone, 50 ml of buffer, 18 ml of alizarin reagent, and 18 ml of the lanthanum nitrate solution.

The Hall-Weinstein method was carried out in the same manner as the Hall method through the diffusion step. After diffusion, the paper wick was placed in a tube containing 3 ml of fluoride-free water. To this was added 3 ml of the lanthanum-alizarin complexone reagent developed by Weinstein (ref. 18). The mixture was allowed to stand at room temperature for 30 min prior to reading the optical density at 610 m μ .

Procedure for the AutoAnalyzer Method

Ashed samples for fluoride analysis are placed in 18 x 150 mm test tubes and dissolved in 1 ml of 2 N $HClO_4$ and then diluted with de-ionized distilled water to a 10 or 20 ml volume. The samples are placed in every sixth position of the large sampler shown in figure 1. Intervening positions of the sampler rack are occupied by test tubes containing distilled water. Each sample is pumped through a proportional pump into the heated and revolving helix of the Digester unit for 1 min at a rate of 4.7 ml/min. Air is pumped with the sample at a rate of 0.82 ml/min. Sulfuric acid (60%) at a rate of 1.71 ml/min is pumped concurrently into the revolving helix. The internal temperature of the helix is maintained at 132 $^{\circ}$ C as measured with a thermometer in the center of the helix. Hydrogen fluoride and water vapor are evolved as the sample-sulfuric acid mixture passes through the helix. The evolved fluoride and water vapors are condensed in a water cooled condenser and a portion of the condensate (1.0 ml/min) is mixed with a stream of the lanthanum-alizarin complexone reagent (1.06 ml/min) (ref. 18). Color development occurs as the stream passes through the

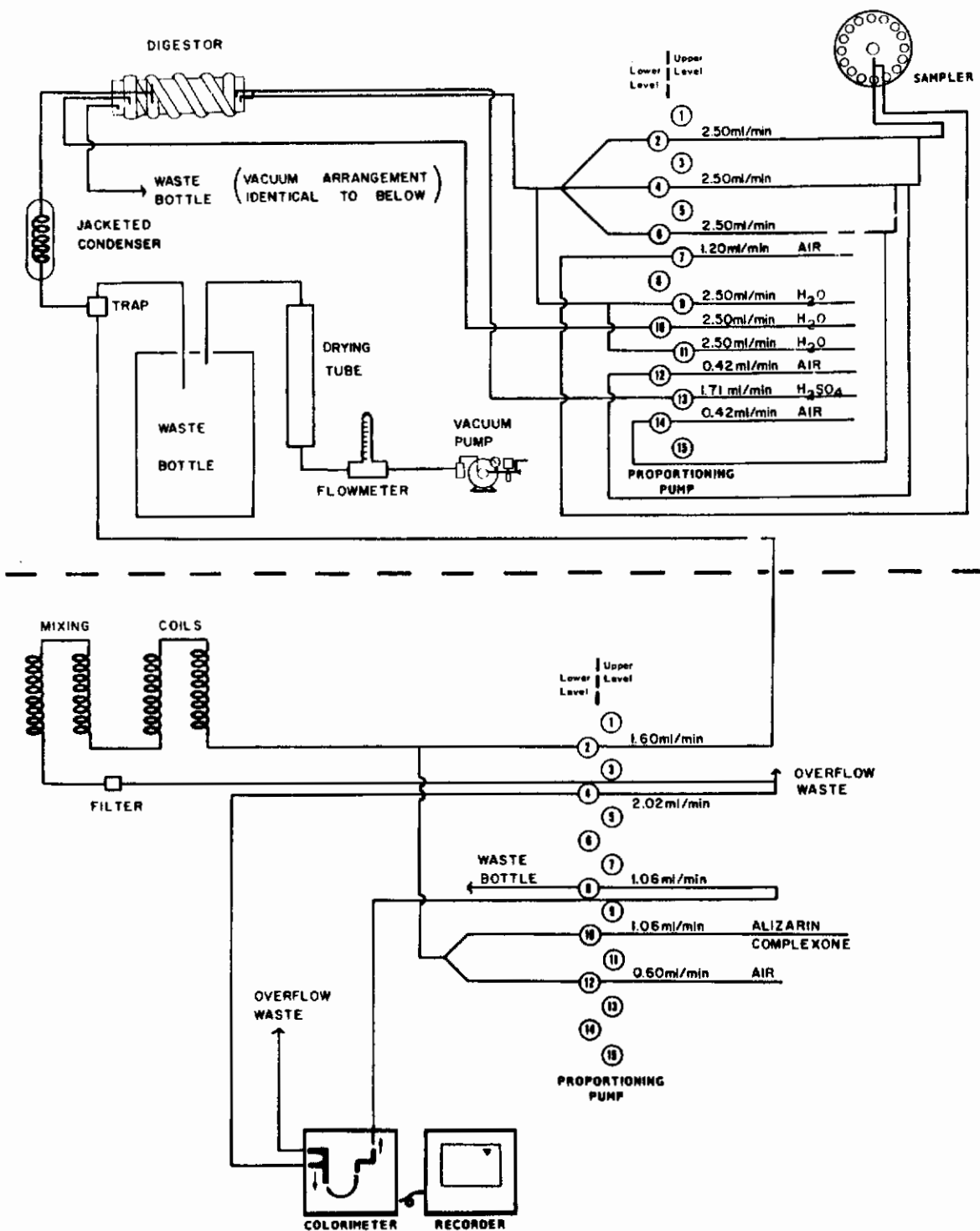

Figure 1. Flow diagram for semiautomated fluoride analysis by the Weinstein method.

time-delay coils. The sample is then pumped through the flow colorimeter and the optical density of each sample is measured at a wavelength of 625 m μ . Samples containing known amounts of fluoride, 2.5 to 100 μ g/20 ml sample volume, are used each day for standards. Total time elapsed from large sampler to readout by the recorder is approximately 13 min.

Hydrogen Fluoride Loss from Samples Dissolved in Perchloric Acid

The rate of loss of fluoride by volatilization from samples dissolved in 0.1 N HClO₄ was measured. Ashed samples were dissolved in 1 ml of 2 N HClO₄, diluted to 20 ml, and analyzed at varying time intervals for fluoride content with the AutoAnalyzer.

SECTION III

RESULTS

Hall Method

The Hall method was found to provide a linear change of optical density with fluoride concentrations up to 1 μ g as shown in figure 2. The method is time consuming and is comparable in this respect except for ashing to the method of Singer and Armstrong (ref. 7). When samples were sufficiently diluted and analyzed for fluoride content, the results were found to be comparable to those obtained by the AutoAnalyzer method as shown in table I. We have not attempted analysis for fluoride in unashed samples using the Hall method in the manner described by Singer and Armstrong. However, the two methods are sufficiently similar in the manner by which the hydrogen fluoride diffusion step is carried out to indicate the Hall method would be satisfactory with unashed samples.

Hall-Weinstein Method

The Hall and Weinstein methods were modified to achieve a working range of 0 to 6 μ g of fluoride per sample. The modification has yielded very good results as indicated by the standard curve shown in figure 3. The optical density per μ g of fluoride ion was found to be slightly less in the modified method than that obtained with the Hall method. Omission of the isobutanol-hydroxylamine extraction and purification procedure saves a considerable amount of time in the

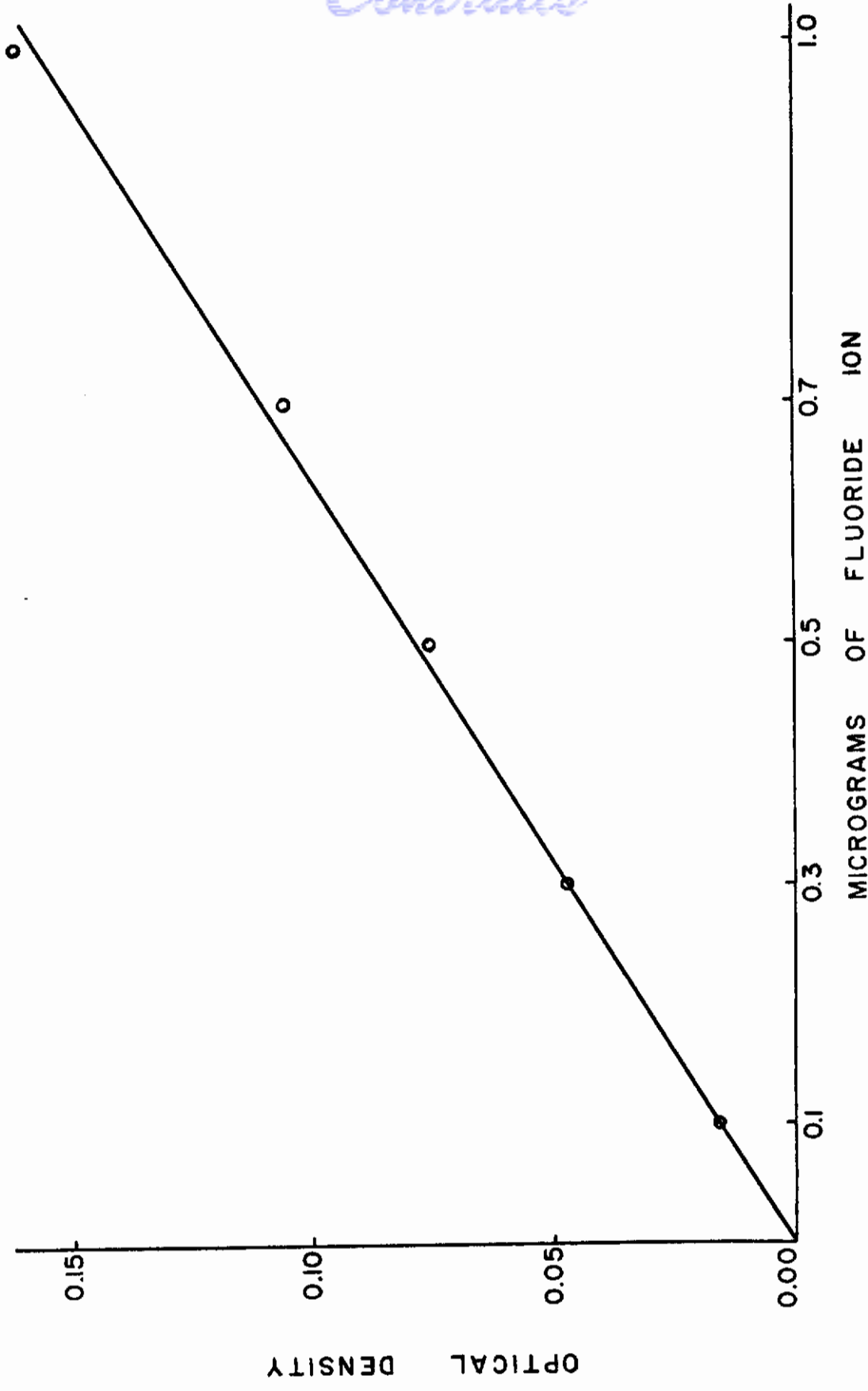

Figure 2. Standard curve for fluoride analysis by the Hall method. A plot of optical density versus micrograms fluoride ion per total sample after diffusion.

Contrails

Table I. Comparison of typical results of fluoride analysis by the Hall and AutoAnalyzer methods.

Type of Tissue Ash	Milligrams of Ash Analyzed	Fluoride Content per 10 mg of Ash	
		AutoAnalyzer Method	Hall Method
Pea seed ash	10	8.0 μ g	10.7 μ g
	10	10	10.8
	20	10.5	
	20	10	
	40	11.3	
Bone ash	10	11	10.1
	20	11.5	
	50	12	
	100	12.6	
Tissue ash	10		10.6
	20	13.5	
	50	13.2	

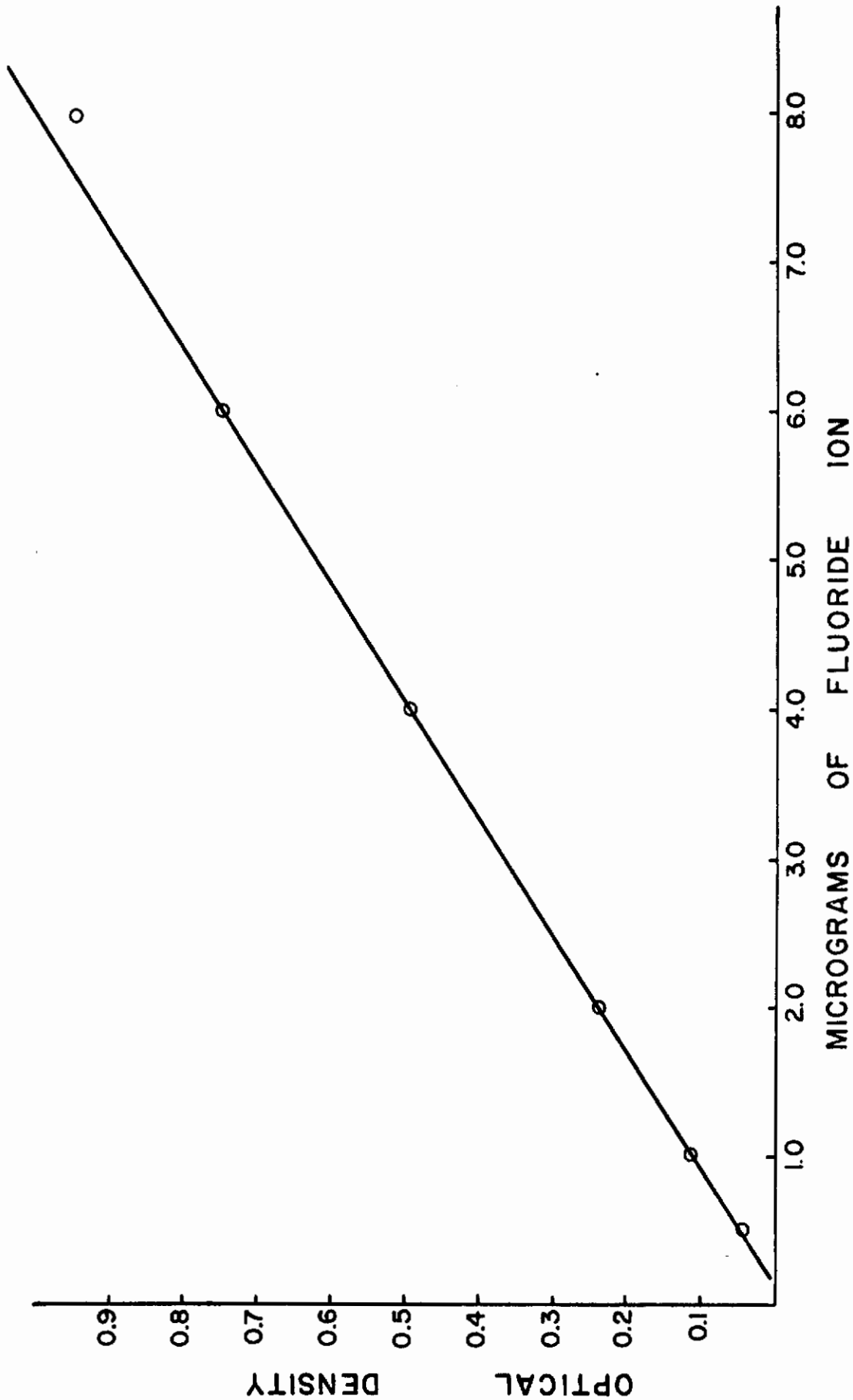

Figure 3. Standard curve for fluoride analysis by the modified Hall method. A plot of optical density versus micrograms of fluoride ion per total sample after diffusion.

analysis after diffusion. However, the standard curve does not pass through zero as was found with the Hall method. Thus, sensitivity is reduced and the total range has been extended to more than 6 μg of fluoride per sample. The modified procedure has enabled us to analyze many samples without repeating the analysis at a lower concentration or smaller sample size. As shown by the results presented in table II, excellent reproducibility is indicated by this method of analysis. Comparison of data obtained by this method with data from the Hall or Auto-Analyzer methods has shown good agreement in absolute values of fluoride present in ashed samples.

Weinstein's AutoAnalyzer Method

The AutoAnalyzer method for fluoride analysis is an excellent method for rapid analysis of ashed samples containing 2.5 to 100 μg of fluoride per sample. The procedure utilized was essentially that of Weinstein, et al. (ref. 18), with one important modification; all ashed material and reference samples were dissolved in perchloric acid just prior to analysis. This modification eliminated clogging of pump tubing by suspended particles of ashed material. No loss of fluoride from samples was detected 60 minutes after being solubilized. After 90 minutes, it was possible to show a detectable loss of fluoride and after 47 hours, approximately 17% of the fluoride was evolved at room temperature. The insignificant loss of fluoride within the first two hours after perchloric acid treatment of the samples made it possible to prepare 20 to 30 samples for analysis at one time.

The reproducibility of the AutoAnalyzer method on repeated analyses of a single sample is shown in table III. In figure 4 is shown the linear response in optical density units to the fluoride content of samples analyzed by this method. A comparison of results obtained from fluoride analysis by the Hall and AutoAnalyzer methods is shown in table I. Very comparable results were obtained by the two methods.

Effect of Ashing Temperature Upon Fluoride Recovery

In table IV are listed the recoveries of added fluorides from samples of plant and animal tissues which were ashed at 400, 500, or 600 $^{\circ}\text{C}$ for 16 hours. Ashing at 400 $^{\circ}\text{C}$ gave maximum recovery of added fluoride when compared to the recovery values at 500 and 600 $^{\circ}\text{C}$. Ashing temperatures below 400 $^{\circ}\text{C}$ resulted in incomplete combustion of both plant and animal tissues. To further investigate the recovery of fluoride added to animal tissues, the experiment described in figure 5 was carried

Table II. Reproducibility of Hall-Weinstein Method.

Samples of various organ tissues from two rats were dried under heat lamps. The dried samples were then ground in a Wiley mill, transferred to nickel crucibles and for each gram of dried sample, 1.5 ml of 1 N lithium hydroxide and 1.0 ml of 0.2 M magnesium succinate were added. After drying under heat lamps the samples were ashed in a muffle furnace at 400° C for 16 hr.

Type of Tissue Ashed	Fluoride Content (µg) per 10 mg Ash		Expressed as µg/gm Wet Weight	
	Rat A	Rat B	Rat A	Rat B
Skin	2.9*	6.1	12.0	25.0
	2.9	6.2		
Digestive tract	3.8	3.7	11.5	11.2
	3.7	3.5		
Muscle	0.3	0.6	1.1	1.7
	0.4	0.6		
Bone	6.6	6.1	455.0	422.0
	6.8	6.5		
Kidneys	1.0	1.0	2.8	2.8
	1.0	1.0		
Liver	3.8	5.1	10.5	13.6
	3.9	5.2		
Lung	1.1	1.5	6.8	5.2
	1.8	1.5		
Heart	1.4	0.9	3.9	2.7
	1.5	1.0		

* Single analysis values

Table III. Reproducibility of fluoride analysis by the AutoAnalyzer Method.

A solution of sodium fluoride (40 μg fluoride ion per 20 ml) in 0.1 N perchloric acid was analyzed repeatedly.

<u>Analysis Sequence</u>	<u>Optical Density</u>	<u>Fluoride Content in Micrograms</u>
1	0.560	43.0
2	0.538	41.3
3	0.528	40.5
4	0.508	39.3
5	0.550	42.5
6	0.538	41.3

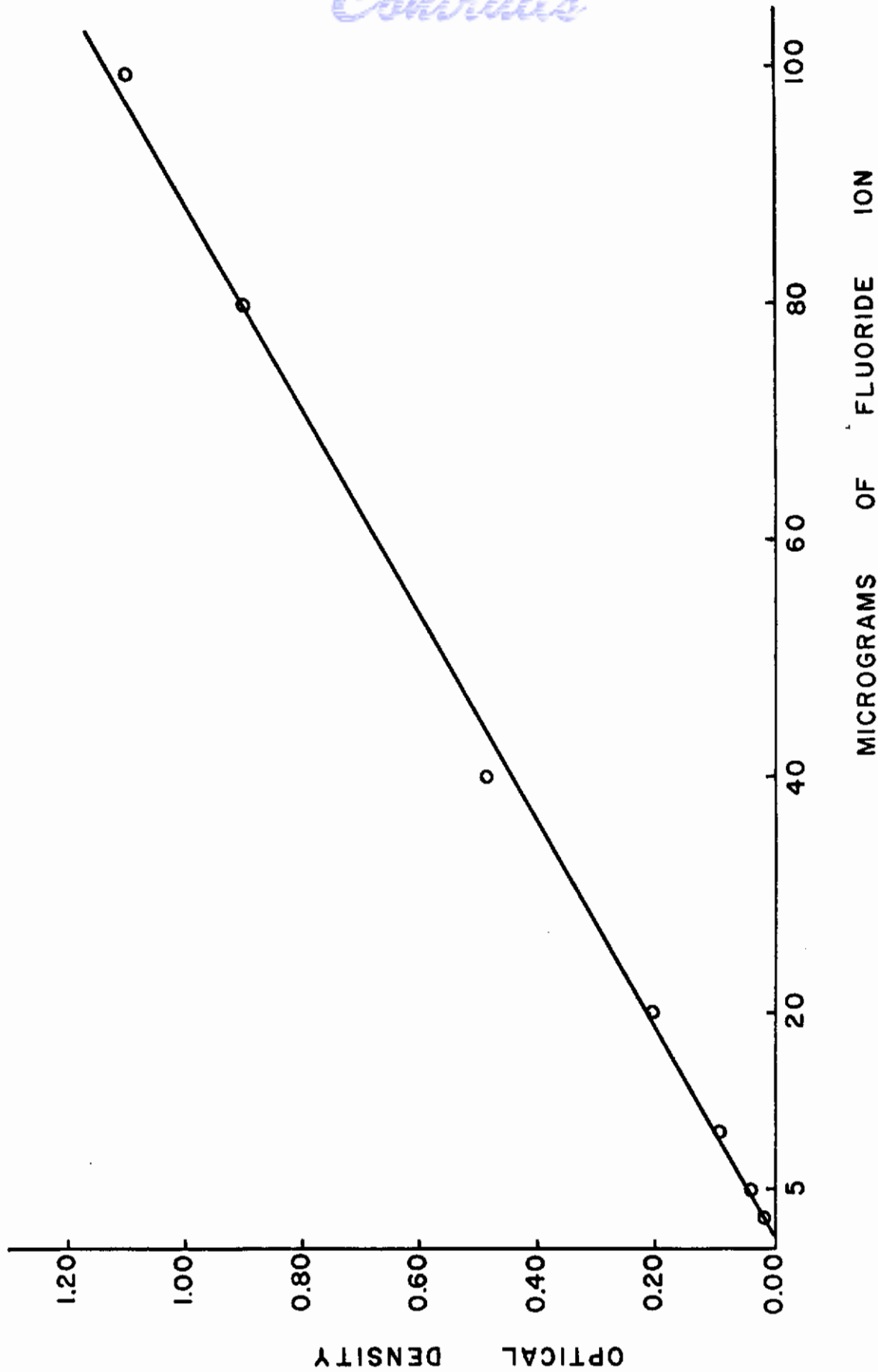

Figure 4. Standard curve for fluoride analysis by the AutoAnalyzer method. A plot of optical density versus micrograms of fluoride ion per 20 ml sample.

Table IV. Effects of ashing temperature upon fluoride recovery.

Samples of dried and ground tissue were placed in nickel crucibles, treated with 1.0 ml of 0.2 M magnesium succinate and 1.5 ml of 1 M lithium hydroxide per gram dry weight, dried under a heat lamp, and fired in an oven for 24 hr. The known amounts of sodium fluoride were added before ashing.

Oven Temperature	Tissue	Fluoride Added μg	Fluoride Found μg
400°C	Pea Seeds (1 gm)	0	3
400	Pea Seeds (1 gm)	100	96
500	Pea Seeds (1 gm)	100	82
600	Pea Seeds (1 gm)	50	2
400	Rat Liver (0.3 gm)	0	13
400	Rat Liver (0.3 gm)	50	75
500	Rat Liver (0.3 gm)	50	45
600	Rat Liver (0.3 gm)	50	14

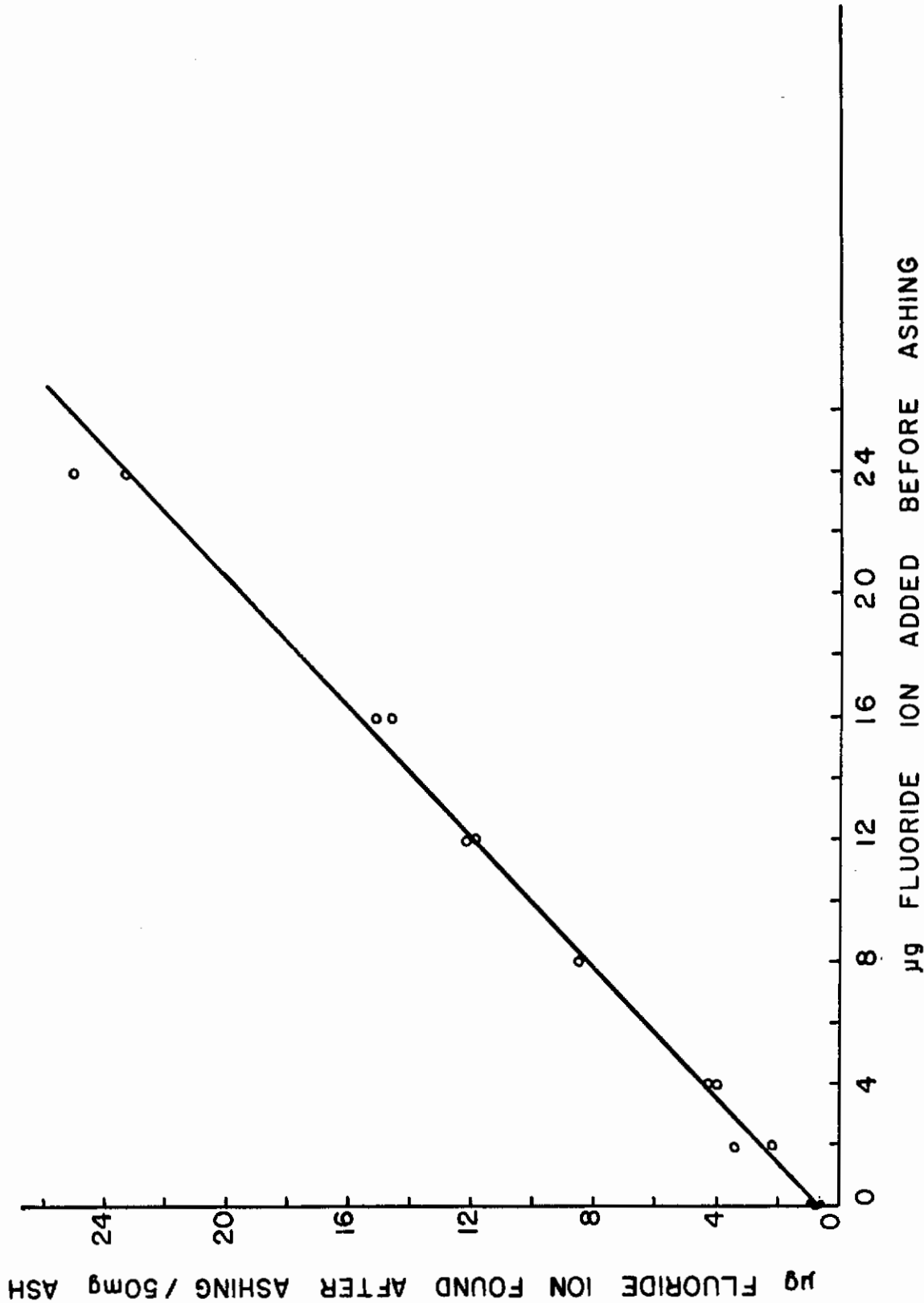

Figure 5. Analysis for added fluoride ion after ashing. Fluoride ion as a sodium fluoride solution was added to dried and ground liver tissue samples (500 mg each) before ashing at 400°C for overnight. Fluoride analysis was performed on the ash using the AutoAnalyzer method.

out. Low concentrations of added fluoride are recovered nearly quantitatively. These results suggest that the values found with various soft tissues are true values and not a result of variation in ashing or analysis. The dried liver tissue used to obtain the data shown in figure 5 was obtained by pooling livers from 4 normal rats. The fluoride content found without addition of fluoride was 0.4 μg per gram of wet weight.

Discussion

The analysis of fluoride ion by the methods described are satisfactory for the determination of fluoride in both plant and animal tissues. However, the concentration of fluoride is so low in soft tissues of animals that fairly large tissue samples are needed for analysis. For example, 0.5 to 1 gm of fresh tissue is required generally to obtain sufficient fluoride to analyze by even the Hall method. In each determination, at least duplicate samples should be run. The method of Singer and Armstrong (ref. 7) also requires plasma or tissue samples of 1 gm or larger for fluoride analysis.

A considerable effort has been expended to verify that each step in our fluoride analysis procedures yields a quantitative recovery of added fluoride ion.

Ashing in the presence of magnesium succinate and lithium hydroxide was found to prevent loss of fluoride due to volatilization. This fixative mixture is superior to either magnesium acetate or magnesium oxide (ref. 19), and in our procedure retains added fluoride during ashing (fig. 5) as was shown by Hall (ref. 14).

From a comparison of the AutoAnalyzer and Hall methods (table I) the presence of chloride ion does not greatly effect the results obtained by the AutoAnalyzer method for fluoride content when ashed samples of less than 50 mg from both plants and animal tissues are analyzed. The Hall method employs silver ion to prevent the trapping of hydrochloric acid during the diffusion of HF. The diffusion of HF in the AutoAnalyzer Digestor is from a H_2SO_4 acid mixture and, therefore, HCl or other volatile acids may diffuse with the HF water-vapor mixture. Singer and Armstrong stated that it was not possible to obtain reproducible results after diffusion of HF from unashed samples which had not been dried prior to the diffusion step (ref. 7). They did not attempt to identify the volatile substances which interfered with the colorimetric analysis of fluoride in the diffusate. In a limited number

of experiments, we have found no detectable loss of added fluoride from biological samples dried in the absence of the magnesium succinate-lithium hydroxide fixative. Singer and Armstrong (ref. 19) did not state whether they examined fluoride losses during the drying of biological tissue for subsequent analysis.

Soft tissues of rats have shown rather wide variation in fluoride content (table II). For example, liver tissue from rats on a normal diet has been found to vary in fluoride content from 0.4 (fig. 5) to 13.6 μg per gm of wet weight (table II). Singer and Armstrong have reported a value of 0.45 μg per gm wet weight for the fluoride content in rat livers (ref. 7). However, they did not state the history of the animals used for analysis.

REFERENCES

1. Remmert, L. F. and T. D. Parks, "Determination of Fluorine in Plant Materials," Anal. Chem., Vol 25, pp. 450-453 (1953).
2. Mavrodineanu, R. and J. Gwirtsman, "Use of Sodium Peroxide Fusion for the Determination of Fluorides in Vegetation," Contributions of the Boyce Thompson Institute, Vol 18, pp. 419-420 (1956).
3. Powell, R. H. and Oscar Menis, "Separation of Fluoride from Inorganic Compounds by Pyrolysis," Anal. Chem., Vol 30, pp. 1546-1549 (1958).
4. Schoniger, W., "Eine Mikroanalytische Schnellbestimmung von Halogen in Organischen Substanzen," Mikrochim Acta, pp. 123-129 (1955).
5. Steyermark, A., R. R. Kaup, D. A. Petras, and E. A. Bass, "Microdetermination of Fluorine in Organic Compounds Following a Modified Schoniger Combustion," Microchem. J., Vol 3, pp. 523-527 (1959).
6. Warf, J. C., W. D. Cline, and R. D. Tevebaugh, "Pyrohydrolysis in the Determination of Fluoride and other Halides," Anal. Chem. Vol 26, pp. 342-346 (1954).
7. Singer, L., and W. D. Armstrong, "Determination of Fluoride," Anal. Biochem., Vol 10, pp. 495-500 (1965).
8. Willard, H. H. and O. B. Winter, "Volumetric Method for Determination of Fluorine," Ind. Eng. Chem. Anal. Ed., Vol 5, pp. 7-10 (1933).
9. Gwirtsman, J., R. Mavrodineanu, and R. R. Coe, "Determination of Fluorides in Plant Tissue, Air and Water," Anal. Chem., Vol 29, pp. 887-892 (1957).
10. Bellack, E., "Fluoride Drinking Waters," McClure, ed., pp. 593-596, U. S. Public Health Service Publication No. 825 (1962).

Contrails

11. Murty, G. V. L. N., T. S. Viswanathan, and V. Ramakrishna, "Estimation of Fluorine in Microgramme Quantities: A Modified Procedure," Anal. Chim. Acta, Vol 16, pp. 213-215 (1957).
12. Frere, F. J., "Specific Microdiffusion Method for the Determination of Fluorine Based on the Lanthanum-Alizarin Complexone Color System," Anal. Chem., Vol 33, pp. 644-645 (1961).
13. Hall, R. J., "The Determination of Microgram Amounts of Fluorine by Diffusion," Analyst Vol 85, pp. 560-563 (1960).
14. Hall, R. J., "The Spectrophotometric Determination of Submicrogram Amounts of Fluorine in Biological Specimens," Analyst, Vol 88, pp. 76-83 (1963).
15. Wharton, H. W., "Recoveries of Fluoride by Microdiffusion: Effect of Heat and Diffusion Time," Anal. Chem., Vol 35, pp. 406-407 (1963).
16. Nielsen, H. M., "Determination of Microgram Quantities of Fluoride," Anal. Chem., Vol 30, pp. 1009-1011 (1958).
17. Talvitie, N. A. and L. A. Brewer, "Separation of Fluoride by Ion Exchange: Application to Urine Analysis," Am. Ind. Hyg. Assoc. J., Vol 21, pp. 287-295 (1960).
18. Weinstein, L. H., R. H. Mandl, D. C. McCune, J. S. Jacobson, and A. E. Hitchcock, "A Semiautomated Method for the Determination of Fluorine in Air and Plant Tissues," Contributions of the Boyce Thompson Institute, Vol 22, pp. 207-220 (1963).
19. Singer, L. and W. D. Armstrong, "Determination of Fluoride in Blood Serum," Anal. Chem., Vol 31, pp. 105-109 (1959).

Security Classification

DOCUMENT CONTROL DATA - R&D		
(Security classification of title, body of abstract and indexing annotation must be entered when the overall report is classified)		
1. ORIGINATING ACTIVITY (Corporate author) Radiation Center Oregon State University Corvallis, Oregon 97331	2a. REPORT SECURITY CLASSIFICATION UNCLASSIFIED	
	2b. GROUP N/A	
3. REPORT TITLE EXPOSURES OF BIOLOGICAL SYSTEMS TO INORGANIC FLUORIDE OXIDIZING AGENTS. II. FLUORIDE ANALYSIS BY CHEMICAL METHODS		
4. DESCRIPTIVE NOTES (Type of report and inclusive dates) Final Report 1 July 1964 - 30 June 1965		
5. AUTHOR(S) (Last name, first name, initial) Reed, Donald J., PhD Dost, Frank N., DVM Wang, Chih H., PhD		
6. REPORT DATE December 1965	7a. TOTAL NO. OF PAGES 25	7b. NO. OF REFS 19
8a. CONTRACT OR GRANT NO. AF 33(615)-1799 b. PROJECT NO. 6302 c. Task No. 630202 d.	9a. ORIGINATOR'S REPORT NUMBER(S) 9b. OTHER REPORT NO(S) (Any other numbers that may be assigned this report) AMRL-TR-65-223-Vol II	
10. AVAILABILITY/LIMITATION NOTICES Distribution of this document is unlimited		
11. SUPPLEMENTARY NOTES	12. SPONSORING MILITARY ACTIVITY Aerospace Medical Research Laboratories Aerospace Medical Division, Air Force Systems Command, Wright-Patterson AFB, Ohio	
13. ABSTRACT <p style="text-align: center;">Methods are described for assaying the fluoride content of ashed samples of plant and animal tissues. Using the Hall method, submicrogram quantities of fluoride were measured and a new procedure was devised to measure fluoride in a 1 to 8 microgram range. Modification of the Weinstein procedure, in which an AutoAnalyzer is used, permitted rapid and semiautomated analysis of samples containing 2.5 to 100 micrograms of fluoride.</p>		

DD FORM 1473
1 JAN 64

Security Classification

Security Classification

14.	KEY WORDS	LINK A		LINK B		LINK C	
		ROLE	WT	ROLE	WT	ROLE	WT
	Fluoride analysis methods Plant & animal tissue Toxicity						

INSTRUCTIONS

1. **ORIGINATING ACTIVITY:** Enter the name and address of the contractor, subcontractor, grantee, Department of Defense activity or other organization (*corporate author*) issuing the report.
- 2a. **REPORT SECURITY CLASSIFICATION:** Enter the overall security classification of the report. Indicate whether "Restricted Data" is included. Marking is to be in accordance with appropriate security regulations.
- 2b. **GROUP:** Automatic downgrading is specified in DoD Directive 5200.10 and Armed Forces Industrial Manual. Enter the group number. Also, when applicable, show that optional markings have been used for Group 3 and Group 4 as authorized.
3. **REPORT TITLE:** Enter the complete report title in all capital letters. Titles in all cases should be unclassified. If a meaningful title cannot be selected without classification, show title classification in all capitals in parenthesis immediately following the title.
4. **DESCRIPTIVE NOTES:** If appropriate, enter the type of report, e.g., interim, progress, summary, annual, or final. Give the inclusive dates when a specific reporting period is covered.
5. **AUTHOR(S):** Enter the name(s) of author(s) as shown on or in the report. Enter last name, first name, middle initial. If military, show rank and branch of service. The name of the principal author is an absolute minimum requirement.
6. **REPORT DATE:** Enter the date of the report as day, month, year, or month, year. If more than one date appears on the report, use date of publication.
- 7a. **TOTAL NUMBER OF PAGES:** The total page count should follow normal pagination procedures, i.e., enter the number of pages containing information.
- 7b. **NUMBER OF REFERENCES:** Enter the total number of references cited in the report.
- 8a. **CONTRACT OR GRANT NUMBER:** If appropriate, enter the applicable number of the contract or grant under which the report was written.
- 8b, 8c, & 8d. **PROJECT NUMBER:** Enter the appropriate military department identification, such as project number, subproject number, system numbers, task number, etc.
- 9a. **ORIGINATOR'S REPORT NUMBER(S):** Enter the official report number by which the document will be identified and controlled by the originating activity. This number must be unique to this report.
- 9b. **OTHER REPORT NUMBER(S):** If the report has been assigned any other report numbers (*either by the originator or by the sponsor*), also enter this number(s).
10. **AVAILABILITY/LIMITATION NOTICES:** Enter any limitations on further dissemination of the report, other than those

imposed by security classification, using standard statements such as:

- (1) "Qualified requesters may obtain copies of this report from DDC."
- (2) "Foreign announcement and dissemination of this report by DDC is not authorized."
- (3) "U. S. Government agencies may obtain copies of this report directly from DDC. Other qualified DDC users shall request through _____."
- (4) "U. S. military agencies may obtain copies of this report directly from DDC. Other qualified users shall request through _____."
- (5) "All distribution of this report is controlled. Qualified DDC users shall request through _____."

If the report has been furnished to the Office of Technical Services, Department of Commerce, for sale to the public, indicate this fact and enter the price, if known.

11. **SUPPLEMENTARY NOTES:** Use for additional explanatory notes.
12. **SPONSORING MILITARY ACTIVITY:** Enter the name of the departmental project office or laboratory sponsoring (*paying for*) the research and development. Include address.
13. **ABSTRACT:** Enter an abstract giving a brief and factual summary of the document indicative of the report, even though it may also appear elsewhere in the body of the technical report. If additional space is required, a continuation sheet shall be attached.

It is highly desirable that the abstract of classified reports be unclassified. Each paragraph of the abstract shall end with an indication of the military security classification of the information in the paragraph, represented as (TS), (S), (C), or (U).

There is no limitation on the length of the abstract. However, the suggested length is from 150 to 225 words.

14. **KEY WORDS:** Key words are technically meaningful terms or short phrases that characterize a report and may be used as index entries for cataloging the report. Key words must be selected so that no security classification is required. Identifiers, such as equipment model designation, trade name, military project code name, geographic location, may be used as key words but will be followed by an indication of technical context. The assignment of links, rules, and weights is optional.