

FOREWORD

This report was prepared by General Dynamics/Astronautics, a Division of General Dynamics Corporation, under Contract No. AF 33(616)-7719. This contract was initiated under Project No. 7381, "Materials Application", Task No. 738103, "Data Collection and Correlation". The work was administered under the direction of the Directorate of Materials and Processes, Deputy for Technology, Aeronautical Systems Division with Mr. Marvin Knight and Mr. C. L. Harmsworth acting as project engineers.

The program at General Dynamics/Astronautics was performed under the direction of Dr. H. F. Dunholter, Director of Research and Development, Dr. V. A. Babits, Manager of Research, and Mr. A. Hurlich, Chief of Materials Research, with Mr. J. L. Christian acting as the Astronautics project engineer.

This report covers the work performed during the period from December 1960 to January 1962.

The author wishes to acknowledge the assistance of his associates who contributed to this study and, in particular, to Mr. A. Hurlich and Dr. J. F. Watson who supplied technical counsel throughout the course of this investigation.

This report was prepared as General Dynamics/Astronautics Report AE62-0102.

Contrails

ABSTRACT

The primary objective of this program has been to develop simple laboratory-type tests to evaluate the toughness of high strength sheet alloys and their complex welded joints at cryogenic temperatures. Another objective of this program has been to obtain useful engineering data on the mechanical properties of a number of materials currently being used or proposed for use in cryogenic-fueled missiles and space vehicles.

The tests employed for evaluating the toughness of sheet materials included notched tensile tests having stress concentration factors of 3.2, 6.3, and 19, cross-tension and tensile shear tests of individual resistance spot welds, and tensile tests of simple fusion welds. These tests were conducted at 78°, -100°, -320°, and -423° F. These data, as well as data obtained from tensile tests of the base metal, percent martensite determinations, and metallographic examinations of fractured coupons, were correlated with low-cycle, high-stress fatigue data obtained on complex welded joints at 78°, -320°, and -423° F. The most consistent index of toughness was found to be the notched ($K_t = 6.3$)/unnotched tensile ratio. The test data are presented in tabular and in graphical form to aid metallurgical and design engineers in the selection of materials for structural applications at cryogenic temperatures.

The test data were reduced by statistical methods and analyzed. The results of the statistical analysis, which included means, standard deviations, and statistical values, are presented and their importance discussed.

A description of the test equipment and experimental procedures for tensile and fatigue testing at room and cryogenic temperatures is given. This report also includes conclusions, recommendations for future work, and references.

PUBLICATION REVIEW

This technical documentary report has been reviewed and is approved.

FOR THE COMMANDER:



W. P. CONRARDY
Chief, Materials Engineering Branch
Applications Laboratory
Directorate of Materials and Processes

Contrails

TABLE OF CONTENTS

| <u>SECTION</u> | <u>TITLE</u> | <u>PAGE</u> |
|----------------|---------------------------------|-------------|
| 1 | INTRODUCTION | 1 |
| 2 | TEST PROGRAM | 3 |
| 3 | MATERIALS | 5 |
| 4 | TEST SPECIMENS | 7 |
| 5 | APPARATUS AND PROCEDURE | 11 |
| 6 | EXPERIMENTAL RESULTS | 15 |
| 7 | STATISTICAL ANALYSIS OF DATA | 17 |
| 8 | DISCUSSION OF RESULTS | 21 |
| 8.1 | 301 Stainless Steel | 21 |
| 8.2 | 304 ELC Stainless Steel | 24 |
| 8.3 | 310 Stainless Steel | 26 |
| 8.4 | AM-355 Stainless Steel | 27 |
| 8.5 | 2014-T6 Aluminum Alloy | 27 |
| 8.6 | 5052-H38 Aluminum Alloy | 29 |
| 8.7 | 5456-H343 Aluminum Alloy | 30 |
| 8.8 | 5Al-2.5Sn Titanium Alloy | 31 |
| 9 | RECOMMENDATIONS FOR FUTURE WORK | 35 |
| 10 | SUMMARY AND CONCLUSIONS | 37 |
| 11 | REFERENCES | 41 |
| | ILLUSTRATIONS | 45 |
| | TABLES | 163 |
| | DISTRIBUTION LIST | 265 |

Contrails

LIST OF ILLUSTRATIONS

| <u>FIGURE NO.</u> | <u>TITLE</u> | <u>PAGE</u> |
|-------------------|---|-------------|
| 1. | Flat Tensile Specimen (Standard) | 45 |
| 2. | Notched Tensile Specimen ($K_t = 3.2$ and 6.3) | 46 |
| 3. | Notched Tensile Specimen ($K_t = 19$) | 47 |
| 4. | Spot Welded Tension and Shear Specimens | 48 |
| 5. | Fatigue Specimen (Longitudinal for Steel and Titanium) | 49 |
| 6. | Fatigue Specimen (Transverse for Steel and Titanium) | 50 |
| 7. | Fatigue Specimen (Longitudinal and Transverse for Aluminum) | 51 |
| 8. | Photograph of Parent Metal and Welded Flat Tensile Specimens | 52 |
| 9. | Photograph of Notched Tensile Specimens | 53 |
| 10. | Photograph of Spot Welded Tension and Shear Specimens | 54 |
| 11. | Photograph of Fatigue Specimens (Steel and Titanium) | 55 |
| 12. | Photograph of Fatigue Specimens (Aluminum) | 56 |
| 13. | Photograph of Fatigue Specimen (Titanium) | 57 |
| 14. | Photograph of Crack Propagation Specimen | 58 |
| 15. | Radiograph of Fusion Welded Fatigue Specimen | 59 |
| 16. | Radiograph of Complex Welded Fatigue Specimen | 59 |
| 17. | Liquid-Hydrogen Cryostat | 60 |
| 18. | Liquid-Hydrogen Test Chamber Being Prepared for Test | 61 |
| 19. | Transfer of Liquid Hydrogen | 62 |
| 20. | Cryo-extensometer | 63 |
| 21. | Fatigue Specimen in Static Test | 64 |
| 22. | Fatigue Specimen in Liquid-Nitrogen Cryostat | 65 |
| 23. | Outdoor Liquid Hydrogen Test Area | 66 |
| 24. | Hydraulic Rams - Fatigue Test Equipment | 67 |
| 25. | Fatigue Test Chamber (for Room Temperature and Liquid-Nitrogen Testing) | 68 |

LIST OF ILLUSTRATIONS (Cont)

| <u>FIGURE NO.</u> | <u>TITLE</u> | <u>PAGE</u> |
|-------------------|---|-------------|
| 26. | Fatigue Test Bed with Liquid-Hydrogen Test Chamber | 69 |
| 27. | View of Liquid-Hydrogen Fatigue Test Chamber | 70 |
| 28. | View of Liquid-Hydrogen Fatigue Test Chamber (Assembled) | 71 |
| 29. | Liquid-Hydrogen Cryostat for Crack Propagation Testing | 72 |
| 30. | Metallographic Laboratory | 73 |
| 31. | F_{ty} Versus Temperature (Longitudinal) | 74 |
| 32. | F_{ty} Versus Temperature (Transverse) | 75 |
| 33. | $F_{ty}/\text{Density}$ Versus Temperature (Longitudinal) | 76 |
| 34. | $F_{ty}/\text{Density}$ Versus Temperature (Transverse) | 77 |
| 35. | F_{tu} Versus Temperature (Longitudinal) | 78 |
| 36. | F_{tu} Versus Temperature (Transverse) | 79 |
| 37. | $F_{tu}/\text{Density}$ Versus Temperature (Longitudinal) | 80 |
| 38. | $F_{tu}/\text{Density}$ Versus Temperature (Transverse) | 81 |
| 39. | Elongation Versus Temperature (Longitudinal) | 82 |
| 40. | Elongation Versus Temperature (Transverse) | 83 |
| 41. | Notched Tensile Strength ($K_t = 3.2$) Versus Temperature (Longitudinal) | 84 |
| 42. | Notched Tensile Strength ($K_t = 3.2$) Versus Temperature (Transverse) | 85 |
| 43. | Notched Tensile Strength ($K_t = 6.3$) Versus Temperature (Longitudinal) | 86 |
| 44. | Notched Tensile Strength ($K_t = 6.3$) Versus Temperature (Transverse) | 87 |
| 45. | Notched Tensile Strength ($K_t = 19$) Versus Temperature (Longitudinal) | 88 |
| 46. | Notched Tensile Strength ($K_t = 19$) Versus Temperature (Transverse) | 89 |
| 47. | Notched ($K_t = 3.2$) / Unnotched Tensile Ratio Versus Temperature (Longitudinal) | 90 |

LIST OF ILLUSTRATIONS (Cont)

| <u>FIGURE NO.</u> | <u>TITLE</u> | <u>PAGE</u> |
|-------------------|---|-------------|
| 48. | Notched ($K_t = 3.2$) /Unnotched Tensile Ratio Versus Temperature (Transverse) | 91 |
| 49. | Notched ($K_t = 6.3$) /Unnotched Tensile Ratio Versus Temperature (Longitudinal) | 92 |
| 50. | Notched ($K_t = 6.3$) /Unnotched Tensile Ratio Versus Temperature (Transverse) | 93 |
| 51. | Notched ($K_t = 19$) /Unnotched Tensile Ratio Versus Temperature (Longitudinal) | 94 |
| 52. | Notched ($K_t = 19$) /Unnotched Tensile Ratio Versus Temperature (Transverse) | 95 |
| 53. | Notched ($K_t = 3.2$) Tensile/Unnotched Yield Ratio Versus Temperature (Longitudinal) | 96 |
| 54. | Notched ($K_t = 3.2$) Tensile/Unnotched Yield Ratio Versus Temperature (Transverse) | 97 |
| 55. | Notched ($K_t = 6.3$) Tensile/Unnotched Yield Ratio Versus Temperature (Longitudinal) | 98 |
| 56. | Notched ($K_t = 6.3$) Tensile/Unnotched Yield Ratio Versus Temperature (Transverse) | 99 |
| 57. | Notched ($K_t = 19$) Tensile/Unnotched Yield Ratio Versus Temperature (Longitudinal) | 100 |
| 58. | Notched ($K_t = 19$) Tensile/Unnotched Yield Ratio Versus Temperature (Transverse) | 101 |
| 59. | Weld Tensile Strength Versus Temperature (Longitudinal) | 102 |
| 60. | Weld Tensile Strength Versus Temperature (Transverse) | 103 |
| 61. | Weld Joint Efficiency Versus Temperature (Longitudinal) | 104 |
| 62. | Weld Joint Efficiency Versus Temperature (Transverse) | 105 |
| 63. | Weld Elongation Versus Temperature (Longitudinal) | 106 |
| 64. | Weld Elongation Versus Temperature (Transverse) | 107 |

LIST OF ILLUSTRATIONS (Cont)

| <u>FIGURE NO.</u> | <u>TITLE</u> | <u>PAGE</u> |
|-------------------|---|-------------|
| 65. | Tension/Shear Ratio of Spot Welds Versus Temperature | 108 |
| 66. | S-N Curve - 301 Stainless Steel (Longitudinal - Joint No. 1) | 109 |
| 67. | S-N Curve - 301 Stainless Steel (Transverse - Joint No. 1) | 109 |
| 68. | S-N Curve - 301 Stainless Steel (Longitudinal - Joint No. 2) | 110 |
| 69. | S-N Curve - 304 ELC Stainless Steel (Longitudinal - Joint No. 1) | 110 |
| 70. | S-N Curve - 304 ELC Stainless Steel (Transverse - Joint No. 1) | 111 |
| 71. | S-N Curve - 310 Stainless Steel (Longitudinal - Joint No. 1) | 111 |
| 72. | S-N Curve - 310 Stainless Steel (Transverse - Joint No. 1) | 112 |
| 73. | S-N Curve - 310 Stainless Steel (Longitudinal - Joint No. 2) | 112 |
| 74. | S-N Curve - 310 Stainless Steel (Transverse - Joint No. 2) | 113 |
| 75. | S-N Curve - AM-355 Stainless Steel (Longitudinal - Joint No. 1) | 113 |
| 76. | S-N Curve - AM-355 Stainless Steel (Transverse - Joint No. 1) | 114 |
| 77. | S-N Curve - AM-355 Stainless Steel (Longitudinal - Joint No. 2) | 114 |
| 78. | S-N Curve - Stainless Steels at 78°F (Longitudinal - Joint No. 1) | 115 |
| 79. | S-N Curve - Stainless Steels at -320°F (Longitudinal - Joint No. 1) | 115 |
| 80. | S-N Curve - Stainless Steels at -423°F (Longitudinal - Joint No. 1) | 116 |
| 81. | S-N Curve - Stainless Steels at 78°F (Transverse - Joint No. 1) | 116 |

LIST OF ILLUSTRATIONS (Cont)

| <u>FIGURE NO.</u> | <u>TITLE</u> | <u>PAGE</u> |
|-------------------|--|-------------|
| 82. | S-N Curve - Stainless Steel at -320°F (Transverse - Joint No. 1) | 117 |
| 83. | S-N Curve - Stainless Steel at -423°F (Transverse - Joint No. 1) | 117 |
| 84. | S-N Curve - Stainless Steel at 78°F (Longitudinal - Joint No. 2) | 118 |
| 85. | S-N Curve - Stainless Steel at -320°F (Longitudinal - Joint No. 2) | 118 |
| 86. | S-N Curve - Stainless Steel at -423°F (Longitudinal - Joint No. 2) | 119 |
| 87. | S-N Curve - 2014-T6 Aluminum Alloy (Longitudinal - Joint No. 1) | 119 |
| 88. | S-N Curve - 2014-T6 Aluminum Alloy (Transverse - Joint No. 1) | 120 |
| 89. | S-N Curve - 5052-H38 Aluminum Alloy (Longitudinal - Joint No. 1) | 120 |
| 90. | S-N Curve - 5052-H38 Aluminum Alloy (Transverse - Joint No. 1) | 121 |
| 91. | S-N Curve - 5456-H343 Aluminum Alloy (Longitudinal - Joint No. 1) | 121 |
| 92. | S-N Curve - 5456-H343 Aluminum Alloy (Transverse - Joint No. 1) | 122 |
| 93. | S-N Curve - 5456-H343 Aluminum Alloy (Longitudinal - Joint No. 2) | 122 |
| 94. | S-N Curve - Aluminum Alloys at 78°F (Longitudinal - Joint No. 1) | 123 |
| 95. | S-N Curve - Aluminum Alloys at -320°F (Longitudinal - Joint No. 1) | 123 |
| 96. | S-N Curve - Aluminum Alloys at -423°F (Longitudinal - Joint No. 1) | 124 |
| 97. | S-N Curve - Aluminum Alloys 78°F (Transverse - Joint No. 1) | 124 |

LIST OF ILLUSTRATIONS (Cont)

| <u>FIGURE</u> | <u>TITLE</u> | <u>PAGE</u> |
|---------------|---|-------------|
| 98. | S-N Curve - Aluminum Alloys at -320°F (Transverse - Joint No. 1) | 125 |
| 99. | S-N Curve - Aluminum Alloys at -423°F (Transverse - Joint No. 1) | 125 |
| 100. | S-N Curve - Ti-5Al-2.5Sn Alloy (Longitudinal - Joint No. 1) | 126 |
| 101. | S-N Curve - Ti-5Al-2.5Sn Alloy (Transverse - Joint No. 1) | 126 |
| 102. | S-N Curve - Ti-5Al-2.5Sn Alloy (Longitudinal - Joint No. 2) | 127 |
| 103. | S-N Curve - Ti-5Al-2.5Sn Alloy (Longitudinal - Joint No. 3) | 127 |
| 104. | Photomicrographs of Fractured Tensile Specimens (301 and 304 Stainless Steels) | 128 |
| 105. | Photomicrographs of Fractured Tensile Specimens (310 and AM-355 Stainless Steels) | 129 |
| 106. | Photomicrographs of Fractured Tensile Specimens (2014-T6 and 5052-H38 Aluminum) | 130 |
| 107. | Photomicrographs of Fractured Tensile Specimens (5456-H343 Al- and Ti-5Al-2.5Sn) | 131 |
| 108. | Photomicrographs of Fractured Tensile Specimens (301 SS) | 132 |
| 109. | Photomicrographs of Fractured Tensile Specimens (304 SS) | 133 |
| 110. | Photomicrographs of Fractured Tensile Specimens (310 SS) | 134 |
| 111. | Photomicrographs of Fractured Tensile Specimens (AM-355 SS) | 135 |
| 112. | Photomicrographs of Fractured Tensile Specimens (2014-T6 Al Alloy) | 136 |
| 113. | Photomicrographs of Fractured Tensile Specimens (5052-H38 Al Alloy) | 137 |
| 114. | Photomicrographs of Fractured Tensile Specimens (5456-H343 Al Alloy) | 138 |
| 115. | Photomicrographs of Fractured Tensile Specimens (Ti-5Al-2.5Sn Alloy) | 139 |
| 116. | Photomicrographs of Resistance Spot Welds (50X) | 140 |

LIST OF ILLUSTRATIONS (Cont)

| <u>FIGURE</u> | <u>TITLE</u> | <u>PAGE</u> |
|---------------|---|-------------|
| 117. | Photomicrographs of Resistance Spot Welds (500X) | 141 |
| 118. | Fractured Fatigue Specimens - 301 SS (78°F) | 142 |
| 119. | Fractured Fatigue Specimen - 301 SS | 143 |
| 120. | Fractured Fatigue Specimens - 304 SS (78°F) | 144 |
| 121. | Fractured Fatigue Specimens - 310 SS (78°F) | 145 |
| 122. | Fractured Fatigue Specimens - AM-355 SS (78°F) | 146 |
| 123. | Fractured Fatigue Specimens - AM-355 SS (-423°F) | 147 |
| 124. | Fractured Fatigue Specimens - 2014-T6 Aluminum Alloy (78°F) | 148 |
| 125. | Fractured Fatigue Specimens - 2014-T6 Aluminum Alloy (-423°F) | 149 |
| 126. | Fractured Fatigue Specimens - 5052-H38 Aluminum Alloy (78°F) | 150 |
| 127. | Fractured Fatigue Specimens - 5456-H343 Aluminum Alloy (-320°F) | 151 |
| 128. | Fractured Fatigue Specimens - Ti-5Al-2.5Sn Alloy (78°F) | 152 |
| 129. | Standard Deviations Versus Temperature (301 SS) | 153 |
| 130. | Standard Deviations Versus Temperature (304 SS) | 154 |
| 131. | Standard Deviations Versus Temperature (310 SS) | 155 |
| 132. | Standard Deviations Versus Temperature (AM-355 SS) | 156 |
| 133. | Standard Deviations Versus Temperature (2014-T6 Aluminum Alloy) | 157 |
| 134. | Standard Deviations Versus Temperature (5052-H38 Aluminum Alloy) | 158 |
| 135. | Standard Deviations Versus Temperature (5454-H343 Aluminum Alloy) | 159 |
| 136. | Standard Deviations Versus Temperature (Ti-5Al-2.5Sn Alloy) | 160 |

LIST OF ILLUSTRATIONS (Cont)

| <u>FIGURE</u> | <u>TITLE</u> | <u>PAGE</u> |
|---------------|--|-------------|
| 137. | Standard Deviations Versus Temperature (Resistance Spot Welds - Tension) | 161 |
| 138. | Standard Deviations Versus Temperature (Resistance Spot Welds - Shear) | 162 |

LIST OF TABLES

| <u>TABLE</u> | <u>TITLE</u> | <u>PAGE</u> |
|--------------|---|-------------|
| 1. | History and Chemical Analysis of Materials | 164 |
| 2. | Inert-Arc Straight Line Fusion Weld Schedules | 165 |
| 3. | Resistance Spot Weld Schedules | 166 |
| 4. | Resistance Seam Weld Schedules | 167 |
| 5. | Properties of 60 Percent Cold Rolled 301 Stainless Steel (0.025 In. Sheet, Washington Steel, Heat No. 49061, Coil No. 7450) | 168 |
| 6. | Properties of 50 Percent Cold Rolled 304 ELC Stainless Steel (0.012 In. Sheet, Rodney Metals, Heat No. 33251) | 174 |
| 7. | Properties of 75 Percent Cold Rolled 310 Stainless Steel (0.020 In. Sheet, Washington Steel, Heat No. 43631, Coil No. 44942) | 180 |
| 8. | Properties of AM-355 Stainless Steel (0.032 In. Sheet, Wallingford Steel, Heat No. 38174) | 186 |
| 9. | Properties of 2014-T6 Aluminum Alloy (0.063 In. Sheet, Aluminum Company of America, AMS-4029) | 190 |
| 10. | Properties of 5052-H38 Aluminum Alloy (0.063 In. Sheet, Aluminum Company of America, QQ-A-318) | 196 |
| 11. | Properties of 5456-H343 Aluminum Alloy (0.063 In. Sheet, Aluminum Company of America, Mil-A-19842) | 200 |
| 12. | Properties of Ti-5Al-2.5Sn Annealed (0.032 In. Sheet, TMCA, Heat No. M-8394) | 204 |
| 13. | Properties of Resistance Spot Welds of 60 Percent Cold Rolled 301 Stainless Steel, (0.025 In. Sheet, Washington Steel, Heat No. 49061, Coil No. 7450) | 210 |
| 14. | Properties of Resistance Spot Welds of 50 Percent Cold Rolled 304 ELC Stainless Steel (0.012 In. Sheet, Rodney Metals, Heat No. 33251) | 212 |
| 15. | Properties of Resistance Spot Welds of 75 Percent Cold Rolled 310 Stainless Steel (0.020 In. Sheet, Washington Steel, Heat No. 43631, Coil No. 44942) | 214 |

LIST OF TABLES (Cont)

| <u>TABLE</u> | <u>TITLE</u> | <u>PAGE</u> |
|--------------|---|-------------|
| 16. | Properties of Resistance Spot Welds of AM-355 CRT Stainless Steel (0.032 In. Sheet, Wallingford Steel, Heat No. 38174) | 216 |
| 17. | Properties of Resistance Spot Welds of Ti-5Al-2.5Sn Alloy, Annealed (0.032 In. Sheet, TMCA, Heat No. M8394) | 218 |
| 18. | Fatigue Properties of Complex Welded Joints of 60 Percent Cold Rolled 301 Stainless Steel (0.025 In. Sheet, Washington Steel, Heat No. 49061, Coil No. 7450) | 220 |
| 19. | Fatigue Properties of Complex Welded Joints of 50 Percent Cold Rolled 304 ELC Stainless Steel (0.012 In. Sheet, Rodney Metals, Heat No. 33251) | 226 |
| 20. | Fatigue Properties of Complex Welded Joints of 75 Percent Cold Rolled 310 Stainless Steel (0.020 In. Sheet, Washington Steel, Heat No. 43631, Coil No. 44942) | 228 |
| 21. | Fatigue Properties of Complex Welded Joints of AM-355 CRT Stainless Steel (0.032 In. Sheet, Wallingford Steel, Heat No. 38174) | 235 |
| 22. | Fatigue Properties of Complex Welded Joints of 2014-T6 Aluminum Alloy (0.063 In. and 0.125 In. Sheet, Aluminum Company of America, AMS-4029) | 238 |
| 23. | Fatigue Properties of Complex Welded Joints of 5052-H38 Aluminum Alloy (0.125 In. Sheet, Aluminum Company of America, QQ-A-318) | 242 |
| 24. | Fatigue Properties of Complex Welded Joints of 5456-H343 Aluminum Alloy (0.063 In. and 0.125 In. Sheet Aluminum Company of America, Mil-A-19842) | 244 |
| 25. | Fatigue Properties of Complex Welded Joints of Ti-5Al-2.5Sn Alloy (0.032 In. Sheet, TMCA, Heat No. M-8394, Mill annealed) | 246 |

LIST OF TABLES (Cont)

| <u>TABLE</u> | <u>TITLE</u> | <u>PAGE</u> |
|--------------|--|-------------|
| 26. | Properties of 60 Percent Cold Rolled 301 Stainless Steel (0.010 In. Sheet, Heat No. 57644, Coil No. 11976) | 251 |
| 27. | Properties of Annealed Ti-5Al-2.5Sn Alloy (0.014 In. Sheet, Republic Steel Co., Heat No. 3930131, Specification GD/A-0-71010) | 252 |
| 28. | Fatigue Properties of Complex Welded Joints of Ti-5Al-2.5Sn Alloy (0.014 In. Sheet, Republic Steel Co., Heat No. 3930131, Spec GD/A-0-71010) | 255 |
| 29A. | Results of Statistical Analysis, F_{ty} (ksi) | 256 |
| 29B. | Results of Statistical Analysis, F_{tu} (ksi) | 258 |
| 29C. | Results of Statistical Analysis, Weld T.S. (ksi) | 260 |
| 29D. | Results of Statistical Analysis, Spot Weld Tension and Shear, Ultimate (lb) | 262 |
| 30. | Materials Recommended for Future Study | 264 |

LIST OF SYMBOLS

| | |
|-----------|--|
| K_t | = stress concentration factor, $\sqrt{a/r}$ |
| a | = one half of the width between notches in notched tensile specimens. |
| r | = radius at the root of the notches. |
| K | = fracture toughness ($\frac{\text{lb}}{\text{in.}^2} \sqrt{\text{in.}}$). |
| σ | = gross stress, ($\frac{\text{lb}}{\text{in.}^2}$). |
| K_c | = fracture toughness at critical crack length, ($\frac{\text{lb}}{\text{in.}^2} \sqrt{\text{in.}}$). |
| G_c | = crack extension force at critical crack length, ($\frac{\text{in.} \cdot \text{lb}}{\text{in.}^2}$). |
| F_{ty} | = 0.2 percent yield strength, ($\frac{\text{lb}}{\text{in.}^2}$). |
| F_{tu} | = tensile strength, ($\frac{\text{lb}}{\text{in.}^2}$). |
| ksi | = 1000 psi. |
| CR | = cold rolled. |
| CRT | = cold rolled and tempered. |
| ELC | = extra low carbon. |
| s | = standard deviation. |
| N | = number of test values. |
| X_i | = test values. |
| \bar{X} | = mean. |
| k | = probability tolerance factor. |
| TS | = tensile strength. |

1 INTRODUCTION¹

Due to the increasing use of cryogenic propellants such as liquid oxygen and liquid hydrogen (boiling points of -297° and -423° F respectively) in current and proposed missiles and space vehicles, the properties of engineering materials at these extreme sub-zero temperatures are of prime importance. Therefore it was the purpose of this program to evaluate the mechanical properties and toughness of a number of high strength structural materials at a series of temperatures from 78° to -423° F. The need for a simple and inexpensive laboratory-type test for evaluating the toughness or resistance to brittle fracture is evident since there are hundreds of high strength alloys which have been proposed for service at cryogenic temperatures. Therefore it was the primary objective of this program to develop a simple and inexpensive test for "screening" purposes to evaluate the toughness of structural materials and their welded joints.

Notched tensile tests, cross-tension and tensile-shear tests of individual resistance spot welds, and tensile tests of fusion welds were included in this program to evaluate the toughness of the materials. Toughness is a property of vital importance in missile design because missile structures are subject to shock-type loads which occur during hydraulic hammering, vibration due to rocket engine firing, action of quick closing valves, etc. Also the structures will contain built-in stress concentrations of varying degrees of intensity due to welding defects, tool marks, assembly eccentricities, random defects in the metal, etc. These conditions all favor brittle failure, and they become even more severe at low temperature in that brittle fracture is more prone to occur at reduced temperatures.

The severest type of toughness test combines high strain rates, sharp notches, and low temperature as typified by the Charpy V-notch test conducted at low temperature. Notched/unnotched tensile tests, rather than Charpy V-notch tests, were used in this investigation as an index of toughness since all of the data reported herein were obtained on relatively thin sheet material and no fully reliable impact test has yet been devised for thin sheet materials. The notched tensile sample allows use of sharp notches and low testing temperatures, but it does not normally permit the high strain rates available in the Charpy V-notch impact test. The initial strain rate at the root of the notch is greater than that encountered in tests of smooth tensile specimens because of the stress concentration effect of the notches.

¹Manuscript released by the author (January 1962) for publication as an ASD Technical Documentary Report.

Notched tensile specimens with stress concentration factors (K_t) of 3.2, 6.3, and 19.0 were selected for use in this investigation. These specimens were chosen because of their use by other investigators and because they offered a wide range of notch acuity. Besides the notched tensile tests, specimens which incorporated resistance spot welds and fusion welds were used to evaluate resistance to brittle fracture.

The need for studies of this type is demonstrated by the paucity of published literature pertaining to this topic, especially in the welded joint configuration (for "state of the art" surveys, see References 1 through 12). The problem is further complicated by the fact that existing theories of metallic deformation and fracture are not sufficiently far advanced to warrant the extrapolation of data downward from higher temperatures (References 13, 14, and 15). For example, the Cr-Mn stainless steels were once considered to possess good cryogenic properties until tests at -320°F proved them to be quite brittle (References 16, 17, and 18); even 301 cold-rolled stainless steel has been found to exhibit some tendencies toward brittle behavior in welded joints at -423°F ; although this grade of steel is usually considered to have excellent low-temperature properties (Reference 19). The lack of understanding of these and other effects illustrates the need for programs to determine the properties of high-strength structural materials at cryogenic temperatures.

Since this program was aimed primarily at missile and space vehicle applications, primary attention was focused on sheet alloys in thicknesses ranging from 0.012 inches to 0.125 inches because large propellant tanks are fabricated from thin gauge sheet. In addition, since weldability is of prime importance in the fabrication of these vehicles, the sheet alloys were tested in both the base metal and welded joint configurations. The materials selected for investigation represent a number of different alloy systems and include stainless steels and aluminum and titanium base alloys. These alloys were selected for investigation because they exhibited one or more of the following characteristics which suited them for missile and space vehicle application: high strength/density ratios; good toughness (i. e., resistance to brittle fracture); adequate weldability; retention of properties at moderately high temperatures; corrosion resistance; and good formability. In order to obtain optimum strength levels, the particular alloys selected for study were either cold worked (i. e., cold-rolled) or heat treated (e. g., age-hardened, or quenched and tempered) to their highest strength levels commensurate with adequate toughness.

2 TEST PROGRAM

The test program consisted of the determination of the tensile properties of parent and weld metal and the fatigue properties of complex welded joints of several high-strength sheet materials from 78° to -423° F. Test materials included stainless steels and aluminum and titanium base alloys which are of interest for application in long-range missiles and space vehicles employing cryogenic propellants.

Test conditions included tensile and notched tensile testing of the base metal, both longitudinal and transverse to the direction of rolling, at 78°, -100°, -320°, and -423° F. Three notched tensile specimens, having K_t values of 3.2, 6.3, and 19.0 were used for evaluation of the materials' toughness. Also included as evaluation tests were cross-tension and tensile-shear testing of individual resistance spot welds and tensile testing of fusion welds at 78°, -100°, -320°, and -423° F. Fatigue tests of complex welded joints were conducted at 78°, -320°, and -423° F to develop a portion of the S-N diagram (stress level versus cycles to failure) for each material in the high-stress, finite-life range. Magnetic, metallographic, hardness, and chemical tests were performed to determine mechanisms and origins of fractures, to observe microstructural details, and to provide information on low temperature embrittlement phenomena and fracture characteristics. References 20 through 23 give complete details of the test program.

Upon completion of the test program, the test data were statistically reduced and analyzed, and the results presented in graphical and tabular form. In order to satisfy the primary objective of the program, which was to develop simple and inexpensive laboratory-type tests to evaluate the toughness of high strength sheet materials at cryogenic temperatures, the data were analyzed to show any correlations between the evaluation tests and the fatigue data. The fatigue data were considered to be indicative of the service behavior of the alloys investigated (References 20 and 25). Data from the evaluation tests, which included notched tensile tests and resulting notched/unnotched tensile strength ratios, fusion-welded tensile tests, and tensile-shear and cross-tension tests of individual resistance spot welds, were analyzed to see which test or tests best predicted the fatigue life of the materials investigated.

A secondary objective of the test program was to provide useful engineering data on the mechanical properties and toughness of a number of high strength sheet materials. Therefore five or more replicate tests were performed and the data statistically reduced to provide information on the tensile and weld tensile properties from 78° to -423° F. Results obtained from the fatigue and evaluation tests were analyzed to determine the materials' toughness at each of the testing temperatures. From these results recommendations concerning the use of each material for pressure vessel

applications were made. The criteria used for determining the materials' toughness at each testing temperature were: adequate fatigue life of welded joints, a notched/unnotched tensile strength ratio of near unity or above, tensile/shear ratio of 0.25 or above as obtained from individual resistance spot welds, an increase in tensile strengths of notched specimens and fusion welded specimens with a decrease in testing temperature, and a consistency in the tensile and fatigue data (a large amount of scatter in the test data indicates possible embrittlement).

3 MATERIALS

The materials selected for testing in this investigation included cold-rolled 301, 304ELC, and 310 stainless steels, cold-rolled and tempered AM-355 stainless steel; 2014-T6, 5052-H38, and 5456-H343 aluminum alloys; and annealed 5Al-2.5Sn titanium alloy. The history and chemical analysis of these materials are presented in Table 1.

These alloys were selected for the following reasons. They are representative of materials which are currently being used or are proposed for use for structural applications in missile and space vehicle systems. The alloys represent two fundamentally different methods of obtaining high strengths. These are cold rolling (301, 304ELC, and 310 stainless steels and 5052 and 5456 aluminum alloys) and heat treating (AM-355 stainless steel and 2014 aluminum alloy). Also, annealed material is represented by the Ti-5Al-2.5Sn alloy. These alloys cover a wide range of resistance to brittle failure, particularly at cryogenic temperatures. Previous data have indicated that the cold-rolled stainless steels at -423°F have decreasing toughness in the order 310, 304ELC, and 301. Also previous data indicated that 2014 and 5052 are tough, whereas 5456 is relatively brittle at -423°F . The AM-355 stainless steel in the CRT condition was expected to have the least resistance to brittle fracture of the alloys investigated at cryogenic temperatures.

The notched tensile data and notched/unnotched tension ratios obtained early in the investigation indicated that the particular heat of Type 301 stainless steel (heat No. 49061) was more brittle at -320° and -423°F than previous heats which had been evaluated at General Dynamics/Astronautics (References 19, 24, and 25). Therefore, another heat of 301 steel (heat No. 57644) was included in the test program. For the same reason, two heats of the Ti-5Al-2.5Sn alloy were evaluated. Heat M-8394 was the original titanium test material evaluated. This heat was purchased to commercial specifications which allows interstitial (C, O_2 , N_2 , and H_2) and iron contents to be too high for adequate toughness at extreme sub-zero temperatures. Since the initiation of this investigation it has been found that the amount of the interstitials and iron must be limited to moderately low values in the Ti-5Al-2.5Sn alloy to retain adequate resistance to brittle failure at -423°F (References 26 and 27). A special Astronautics specification (GD/A-0-71010) which limits the interstitial elements and iron contents was prepared for the purchase of Ti-5Al-2.5Sn alloy. Heat 3930131 was purchased to this specification. Tensile and fatigue property data obtained on this heat are reported.

The materials were tested in the as-received condition (as shown in Table 1) with no further cold working or heat treatment. Physical properties and chemistry met the specifications for which they were purchased for each of the alloys investigated.

Contrails

4 TEST SPECIMENS

The test specimens used in this investigation included a standard flat tensile specimen, three different notched tensile specimens, cross-tension and tensile-shear spot-welded specimens, and a number of large fatigue specimens (38 inches long) containing complex-welded joints. A drawing of the flat tensile specimen used for base metal and fusion weld tensile testing is shown in Figure 1. A photograph of typical specimens is shown in Figure 8. Drawings of the notched tensile specimens are shown in Figures 2 and 3. Figure 3 presents those notched specimens having stress concentration factors of 3.2 and 6.3. Figure 4 shows the drawing of the notched tensile specimen with a K_t of 18.7. A photograph of typical notched specimens is shown in Figure 9. There are several methods for determining the stress concentration factor of a notched specimen. The stress concentration factors referred to throughout this report were determined by means of the equation: $K_t = \sqrt{a/r}$ where K_t is the stress concentration factor, a is one half of the distance between the notches and r is the radius at the root of the notches. Stress concentration factors as determined by Peterson's equation (Reference 28) and by Neuber's concept (Reference 29) are presented below:

| | <u>Notch "B"</u> | <u>Notch "A"</u> | <u>Sharp Notch</u> |
|-------------------------------------|------------------|------------------|--------------------|
| Total Width (Inches) | 0.4 | 0.4 | 1.0 |
| Width between Notches (2a) (Inches) | 0.2 | 0.2 | 0.7 |
| Radius (r) (Inches) | 0.01 | 0.0025 | 0.001 |
| $K_t (\sqrt{a/r})$ | <u>3.2</u> | <u>6.3</u> | <u>18.7</u> |
| K_t (Peterson) | 3.8 | 7.2 | 21.0 |
| K_t (Neuber) | 3.9 | 7.5 | -- |

Dimensional tolerances for machining of the test specimens (see Figures 2 and 3) allow stress concentration factors which may vary as much as 15 percent; therefore, the K_t was calculated by means of $\sqrt{a/r}$ for each notch specimen tested and is presented in parenthesis with the notched tensile data in Tables 5 through 12. The cross-tension and tensile-shear resistance spot-welded specimens are shown in Figures 4 and 10. Drawings of the fatigue specimens are given in Figures 5, 6, and 7, and photographs of typical specimens are shown in Figures 11, 12, and 13. Figure 5 gives the print used for machining the stainless steel and titanium longitudinal fatigue specimens. Figure 6 gives the machining print for the transverse fatigue specimens for stainless steels and titanium alloys. The print shown in Figure 7 was used for both the longitudinal and transverse fatigue specimens of the three aluminum alloys. The joints referred to in Tables 18 through 25 are as follows:

For Stainless Steels and Titanium:

Longitudinal Joint No. 1 refers to the complex-welded fatigue specimens with a doubler sheet attached by four rows of spot welds on each side of the fusion weld joint (shown in Figures 5 and 11).

Longitudinal joint No. 2 refers to the complex-welded fatigue specimens with two rows of spot welds on each side of the fusion weld (same as joint No. 1 except the outer two rows of spot welds on each side of the fusion weld are deleted). Figure 11 shows a typical specimen having a joint No. 2 configuration.

Longitudinal joint No. 3 (titanium only) refers to the welded fatigue specimen with no doubler attached. This specimen is machined per the print given in Figure 5; however, the joint consists of only a fusion weld with no doubler. Figure 13 shows a typical fatigue specimen having a joint No. 3 configuration.

Transverse joint No. 1 refers to the complex welded joint which is composed of an overlapping joint welded by resistance roll seam welding with one row of resistance spot welds on each side of the roll seam weld. The print for this specimen is given in Figure 6 and a typical specimen is shown in Figure 11.

Transverse joint No. 2 (310 stainless steel only) is the same joint as longitudinal joint No. 1; however, the material is tested in the transverse direction.

For Aluminum Alloys:

Longitudinal and transverse joint No. 1 refers to the fusion-welded fatigue specimens as shown in the print in Figure 7. The longitudinal and transverse specimens have the same joint configuration. A typical specimen is shown in Figure 12. Also shown is the fatigue specimen with a thicker area at the joint accomplished by machine milling on both sides of the fusion weld.

Longitudinal joint No. 2 refers to a complex joint containing a doubler sheet fusion welded to the specimen at the fusion-weld area. This joint contains no spot welds. A typical specimen is shown in Figure 12 (center specimen).

The procedure for specimen preparation was as follows. Specimen layout and identification was made on the sheet materials. Specimen blanks were then sheared and those specimens requiring fusion or resistance roll seam welding were welded. The fusion-weld, spot-weld, and roll-seam-weld schedules are given in Tables 2, 3, and 4. All the welds were visually inspected and some were inspected by means of an x-ray examination. Typical radiographic prints of welded joints of fatigue specimens are shown in Figures 15 and 16. The specimen blanks were then machined and surfaces

prepared for testing and then inspected. Any specimens which were not within the dimensional tolerances of the machining prints were discarded. Doublers were then spot welded on the fatigue specimens. Notched tensile specimens were measured by means of an optical comparator. Smooth tensile and fatigue specimens were measured to 0.0001 inch by means of a micrometer.

A few crack propagation tests were made during this investigation. The specimens used for this testing are shown in Figure 14.

Contrails

5 APPARATUS AND PROCEDURE

The tensile specimens were tested on a 30,000-pound Tinius-Olsen or a 50,000-pound Baldwin-Emery universal testing machine equipped with continuous stress-strain recorders and strain pacers. Specially constructed cryostats were used for testing at sub-zero temperatures. Small, open cryostats were used for tests at -100° F by immersion of the specimens in a bath of dry ice and alcohol and at -320° F by immersion in liquid nitrogen. Cryostats which were specially designed for tensile testing in liquid hydrogen were used for tensile tests conducted at -423° F.

The liquid-hydrogen cryostats, pull rods, grips and other accessories are constructed from 321 stainless steel. The liquid-hydrogen chambers are insulated by a concentric vacuum space, a liquid-nitrogen bath, and foamed polyurethane insulation. Lids provided with ports for the pull rods, exhaust vents, and extensometers are gas-tight fits to the chambers by means of mechanical clamps and Teflon O-ring seals. Temperature measurement is accomplished by means of copper-constantan thermocouples. Liquid-level indicators, using carbon-resistor sensors, are used to monitor the amount of liquid hydrogen present in the test chambers. Immersion type heater elements are used to boil off the liquid hydrogen upon completion of each test. A heater was chosen over other means of removing the liquid hydrogen because it permits rapid testing, is simple in design, is easy to use, and allows for greater safety. Figures 17, 18, and 19 show views of the two liquid-hydrogen cryostats used for tensile testing in this investigation. Figure 17 shows the pull rod with universal joint, stainless steel flex line for exhaust of hydrogen gas, the lid clamped into position and electrical leads to the heater, liquid-level indicator, thermocouples, and extensometer. Figure 18 shows a specimen being loaded into the liquid-hydrogen cryostat. The dewar at the right contains liquid nitrogen which is used as an insulation jacket. Figure 19 shows the transfer of liquid hydrogen from a 50-liter dewar to the test chamber through a vacuum-insulated transfer line. A gas analyzer is being used to determine the amount of hydrogen gas escaping into the laboratory. Also shown in Figure 19 is a view of one of the cryogenic laboratories equipped for liquid-hydrogen testing. The ceiling is gas tight and tapers to the center of the room where three explosion-proofed motors and fans create a circulation of air in the laboratory at the rate of four changes per minute. All lights and electrical connections and equipment higher than three feet above the floor are explosion proofed. All equipment which could not be explosion proofed was placed inside the operator's room, shown in Figure 19.

Continuous recordings of stress-strain curves were accomplished by means of standard extensometers for the room temperature tests and specially designed cryo-extensometers for the sub-zero temperature tests. An assembly view of a cryo-extensometer, clamps, and a tensile specimen is shown in Figure 20. The cryo-extensometer used to measure strain in the gauge length of the specimen uses two knife edges clamped to the specimen. The knife edges are attached to tubes extending

outside the liquid-hydrogen chamber. Thus strain in the specimen results in differential movement of the two tubes which protrude above the cryostat. This differential movement, which is proportional to strain, is used as the input (through a lever) to a differential-transformer-type transducer. The output of this transducer is an electrical signal which is used to control the abscissa (strain axis) of an automatic recorder that produces a continuous stress-strain curve.

Figure 20 shows how both the extension tubes and transducer are attached to a frame and connected to each other through a lever system.

The knife edges are attached to the specimen with the help of a precision gage block which ensures that the knife edges are parallel and separated by the gage length desired (two inches in this case). The extensometer is designed to withstand severe shock without damaging the equipment so that strain can be recorded until specimen fracture. The sensitivity of the extensometer system is 0.0001 inch. The extensometers as well as the strain pacer, stress-strain recorder, and the load cells are periodically standardized and their accuracy checked.

The sequence of operations in performing the tensile tests is as follows. The specimens are checked for surface defects, measured by means of a micrometer, and gage marked for total elongation determination. The specimens are placed in the equipment and brought to the proper temperature by means of dry ice and alcohol (-100°F), liquid nitrogen (-320°F), or liquid hydrogen (-423°F). The temperature of the test specimen is measured by means of copper-constantan thermocouples. The specimens are loaded in tension until failure at the following rates: 0.001 in./in./min until 0.2-percent yield followed by 0.15 in./min until failure for the parent metal and fusion-welded tensile tests; 0.001 in./in./min as determined by an extensometer (about 0.01 to 0.02 in./min) for the notched tensile tests; 0.1 in./min for the spot-welded cross-tension and tensile-shear tests. Upon failure the specimen is removed and another prepared for test. Each test is assigned a run number, and all data, including specimen number and measurements, test temperature, loads, stress-strain curve, strain rate, elongation, and special remarks, are recorded. The results, as reported in Tables 5 through 12, are then determined.

A thorough description of the liquid-hydrogen cryostats, cryo-extensometers, and accessory equipment, as well as the safety features, rapidity of testing, and sequence of operations may be found in Reference 30.

The high-stress, low-cycle fatigue tests were conducted on a series of hydraulic test beds. Figure 21 shows a static tensile test being performed on a 301 stainless steel fatigue specimen at room temperature. Figure 22 shows the same type of test being performed at -320°F . These specimens are being static tested on a 200,000-pound Tinius-Olsen universal testing machine. Figure 23 shows a view of the outdoor liquid-

hydrogen testing area where the fatigue tests are performed. The dewar trailers shown in Figure 23 contain liquid nitrogen and liquid hydrogen. The test console is shown in the foreground. The test beds are located in the small building (center of photo). The building is equipped with blower fans which circulate the air during the test. Gaseous hydrogen may be seen escaping to the atmosphere at the top of the exhaust stack. Figure 24 shows the hydraulic rams which are used on one of the four test beds. Test gages, such as shown in Figure 24, are located at the test beds and at the test console (located about 20 yards from the test beds). Automatic cycling apparatus equipped with counters is used to monitor the fatigue tests with minimum operators' attendance. One of the test beds is shown in Figure 25. The specimen, which is shown loaded in the test bed, may be tested at room temperature or at -320°F (by filling and maintaining the insulated test chamber with liquid nitrogen). A photo of a fatigue specimen being prepared for testing at -423°F is shown in Figure 26. The liquid-hydrogen cryostat, also shown in Figures 27 and 28, is positioned on the fatigue specimen. The specimen is then mounted in the test bed which is filled with liquid nitrogen. The liquid-hydrogen cryostat is then filled and maintained with liquid hydrogen. After the specimen has come to temperature, the fatigue test is conducted. Shown in Figure 26 is the vacuum-insulated fill line, exhaust line, and electrical leads to a liquid-level sensor and thermocouple.

The sequence of operations for fatigue testing is as follows. The specimens are inspected and area determinations made. The specimens are placed in the test bed and brought to test temperature. Loads are set by means of a test gage and a four-way, solenoid operated, hydraulic control valve. The test is operated automatically with the number of cycles determined by an electrical counter. The fatigue tests are conducted at the rate of six cycles per minute. Static tests are performed at 0.001 in./in./min until failure.

In addition to the tensile and fatigue tests, a few crack propagation tests were made during this study. The cryostat used for these tests is shown in Figure 29. Observation of the specimen (shown in Figure 14) and the extension of the crack upon loading is made by means of a simple optical system. More information on the crack propagation testing apparatus and procedure may be found in Reference 31.

The failed tensile and fatigue specimens were visually observed, hardness and magnetic (for steels) measurements were made; and fractured edges mounted for metallographic examination. These tests were made to help determine the mechanism and origins of fractures, to observe microstructural details, and to provide information on low-temperature embrittlement phenomena and fracture characteristics. Hardness measurements were performed on a Rockwell Superficial hardness tester using the 15-N scale. Magnetic measurements were made by means of a Magne-Gage which had been calibrated to read directly in terms of percent martensite present in stainless steels (Reference 32). Metallographic studies were made with conventional equipment. Figure 30 is a view of the metallography laboratory showing metallurgical microscopes, metallograph, and electron microscope.

Contrails

6 EXPERIMENTAL RESULTS

Mechanical property data on base metal tensile tests are given in Tables 5 through 12, 25, and 26 for the materials tested in this investigation. These tables include yield (0.2 percent offset) and tensile strengths at each testing temperature. These data are plotted as a function of temperature in Figures 31 through 38. Total elongations are reported in the tables and plotted in Figures 39 and 40. Notched tensile strengths, notched/unnotched tensile ratios, fracture toughness and stress concentration factors are given in Tables 5 through 12. The notched data are shown graphically in Figures 41 through 58. The stress concentration factor (K_t) of each individual notched specimen is reported in parenthesis with the notched tensile data. The fracture toughness values were calculated from the equation $K^2 = \pi a \sigma^2$ where K is the fracture toughness, a is one half of the initial crack (notch) length and σ is the gross stress (Reference 33). It should be noted that the fracture toughness values reported in Tables 5 through 12 were calculated from initial crack (notch) lengths and not the critical crack lengths. Therefore, the values reported are K values, not K_C values, and as such may be conservative. Some K_C and G_C data are reported for Type 301 stainless steel (reported in Section 8). Tensile data obtained on single fusion welds are reported in Tables 5 through 12, 26, and 27. Tensile strengths, joint efficiencies, and elongations of the welds are shown as a function of test temperature in Figures 59 through 64. Hardness values and magnetic measurements of fractured tensile specimens are reported in Tables 5 through 12.

Cross-tension and tensile-shear data obtained on individual resistance spot welds are reported in Tables 13 through 17. These data are shown graphically as a function of temperature in Figure 65.

The high-stress, low-cycle fatigue data are reported in Tables 18 through 26 and Table 28. S-N (stress level versus number of cycles to failure) curves were plotted from the fatigue data and are shown in Figures 66 through 103.

Photographs were made of typical tensile and fatigue specimen fractures. Figures 104 through 107 show typical failures of base metal and simple fusion-weld tensile specimens. Typical fractures of the fatigue specimens are shown in Figures 118 through 128. Photomicrographs were made on fractured edges of tensile specimens and are shown in Figures 108 through 115. Photomicrographs of resistance spot welds are shown in Figures 116 and 117.

Results of a statistical reduction and analysis of the tensile data of base metal, fusion welds and cross-tension and tensile-shear data of resistance spot welds are given in Table 30 and Figures 129 through 138.

Contrails

7 STATISTICAL ANALYSIS OF DATA

A statistical analysis was performed on each of the alloys tested in this investigation. Results of the statistical analysis are reported for F_{ty} , F_{tu} , and weld tensile strengths for both the longitudinal and transverse directions, and cross-tension and tensile-shear strengths of individual resistance spot welds. The data for each of the test temperatures were analyzed.

Mean values, standard deviations, and 90- and 99-percent probability (with 95-percent confidence) values were obtained for the particular heats and coils of materials tested. The 90- and 99-percent levels employed herein statistically correspond, respectively, to the "B" and "A" values as discussed in MIL-HDBK-5, March 1959 (Reference 34). The "B" and "A" values are not considered to be material design allowables because only one heat and coil of each material was tested which probably would not be fully representative of all material produced to the same specifications. Therefore, the 90- and 99-percent levels may be considered to be "B" and "A" design allowables only for the particular coils tested.

For the purposes of this report, an "A" value will be considered to be that level which would be exceeded by at least 99 percent of the population; i. e., the confidence is 95 percent that 99 percent of all the test data, for each test condition obtained from the tested heat and coil of material, would exceed the "A" value. The "B" value is similarly defined for 90-percent probability and 95-percent confidence. The material property data were analyzed independently for each test condition. For F_{ty} , F_{tu} , and weld tensile strength, five test values were analyzed for each combination of eight materials, two grain directions, and four temperatures. For spot-weld tensile and shear strengths, twenty test values were analyzed for each combination of five materials and four temperatures. In each case the sample standard deviation (s) was calculated from the following equation:

$$s = \sqrt{\frac{\sum_{i=1}^N (X_i - \bar{X})^2}{N - 1}}$$

Where N = number of test values,

X_i = test values, and

$$\bar{X} = \frac{1}{N} \sum_{i=1}^N X_i .$$

The "A" and "B" values were evaluated by subtracting from \bar{X} the product ks , where k is the applicable probability tolerance factor as follows:

$$X_B = \bar{X} - k_B s$$

$$X_A = \bar{X} - k_A s$$

Reference 35 contains tables of the one-sided tolerance factors for the normal distribution at the desired levels of probability and confidence. The assumption of normality in the analyses is justifiable on the basis of the small sample sizes. Previous investigations of strength properties having large sample sizes indicate that the distribution functions are often slightly non-normal (Reference 36). In many cases, the log-normal distribution best describes the total population due to the influence of specification minimum requirements, quality control, etc. However, the use of non-normal distribution functions with small sample sizes where the population distribution function is not definitely known may lead to erroneous results. The normal or Gaussian distribution function was therefore adopted for the analysis of the data herein.

The data were coded for and analyzed on an IBM 7090 digital computer. The results of the statistical analysis are presented in Table 29. Included in Table 29 are the means, standard deviations, and "A" and "B" values. An effort was made to indicate possible misleading values resulting from the statistical study. In general, for mechanical property data of engineering materials, the "A" value should exceed 80 percent of the mean. Those "A" values given in Table 29 which did not exceed 80 percent of the mean are indicated by means of an asterisk. There are several possible explanations for the large standard deviations, and thus low design allowable values, for the cases noted. There may have been too few of a number of test values, in which case additional testing would have to be performed to obtain better estimates of the population parameters. It may be that even with additional testing the dispersion of the data would remain large, in which case, it is possible that the data are not definitive enough to permit a reasonable statistical evaluation. Large standard deviations may also be a result of the material, fabrication of the test specimen, or testing equipment and procedure. A more thorough study of the standard deviations as a function of test temperature was made. The results are plotted in Figures 129 through 138. In general, the standard deviations increase with decrease in testing temperature, and the standard deviations are larger for the tensile strengths of welds than for the base metal. The explanation for the latter case is that the welding process has introduced other factors which would tend to increase the amount of scatter in the tensile data. These factors include porosity, lack of fusion, gas absorption, thinning, mismatch, presence of intermetallics in the heat

affected zone (which tends to decrease the resistance to brittle fracture) , etc. Although the welds were found to be radiographically sound and acceptable per industrial standards, it is felt that the added factors introduced by the presence of the welds may be responsible for those cases in which the dispersion of the tensile data was greater for the weld metal than for the parent metal.

The general increase of standard deviations with decrease in testing temperature is felt to be due to several reasons. The values of the test data generally increase with decrease in testing temperature; therefore, a larger standard deviation (actual value, not percent of standard deviation with respect to mean value, i. e. s/\bar{X}) would be expected. Graphs of s/\bar{X} versus temperature were plotted to determine the validity of this explanation. It was found that the s/\bar{X} values when plotted versus temperature did not increase as much with decrease in test temperature as for the s versus temperature plots. This would indicate that the effect of increasing test values with decreasing temperatures was to increase the standard deviation at the lower test temperatures. However, this does not totally explain the increase of standard deviation with decrease in temperature because, in general, the values of the standard deviations divided by the means (s/\bar{X}) also increased with decrease in temperature. A possible explanation for the increased scatter of test data at sub-zero temperatures is the greater likelihood of experimental error at the lower temperatures due to the necessary increase in complexity of the test equipment. It is believed that a more likely explanation, however, is that some of the materials tested in this investigation become less tough with decrease in temperature and that decreased toughness (embrittlement) is directly proportional to increased scatter in the test data. Previous data have indicated that a greater spread of test values is obtained for the more brittle materials than for tough materials (Reference 25) . As may be seen in Table 29 and Figures 129 through 138, those materials with large standard deviations and low "A" and "B" values (as compared to the mean values) , for a particular test condition (temperature, grain direction) , appear to be less tough as determined by notched tensile tests, spotweld tensile and shear tests, and fatigue tests. An exception to this is the weld tensile data which was discussed previously, and is felt to be due to the presence of the weld. It is believed that a statistical analysis (particularly s/\bar{X} versus temperature) of tensile test data can be used in the evaluation of the toughness of a material, and it is suggested that further efforts be made in the development of this method of evaluating candidate materials for structural applications at cryogenic temperature.

It is again emphasized that the "A" and "B" values as given in Table 29 are not intended as design allowables for the materials but are, as defined previously, probability values based upon tests from one coil of one heat of each material.

Contrails

8 DISCUSSION OF RESULTS

Each of the alloys tested in this investigation will be discussed individually to provide maximum clarification and interpretation of the experimental results. This is necessary due to the large amount of data obtained in this study. Several correlations between the data of one alloy and another, however, are noted and graphs of tensile and fatigue properties of all the alloys are shown in Figures 31 through 65, 78 through 86, 94 through 99, and 137 and 138.

8.1 301 STAINLESS STEEL. Base metal tensile, notched tensile, and fusion-weld tensile data at 78°, -100°, -320°, and -423° F are presented for one heat of 60-percent cold-rolled Type 301 stainless steel in Table 5 and Figures 31 through 64. Table 13 and Figure 65 present cross-tensile and tensile-shear data on individual resistance spot welds of this alloy at the same temperatures. High-stress, low-cycle axial fatigue data obtained on complex-welded joints are presented in Table 18 and Figures 66 through 68 and 78 through 86. Results of a statistical analysis of these data are given in Table 29 and Figures 129, 137, and 138. Photographs of typical fractures of base metal and welded tensile specimens are shown in Figure 104 with photomicrographs of the fractured edges shown in Figure 108. Fractures of fatigue specimens were similar at each testing temperature and are typified by those failures shown in Figure 118. Figure 119 shows a failure in the base metal, indicating 100-percent joint efficiency.

As may be seen in Tables 1 and 5, the 301 material meets Specification GD/A-0-71004 with respect to chemistry and room temperature base metal mechanical properties (minimum F_{ty} of 160 ksi; minimum F_{tu} of 200 ksi; minimum elongation of 2.0 percent). There are, however, several notable differences between this particular heat (49061) of material and those which have been tested previously (References 19 and 24), and it was for this reason that another heat of Type 301 stainless steel was included in the test program in addition to the initial one. The tensile and fatigue property data obtained on the second heat (57644) are presented in Table 26. The differences in heat 49061 and previous heats, as mentioned above, include: greater directionality effects (F_{ty} and F_{tu} at 78° F) than normal; very low notched tensile strengths ($K_t = 6.3$) and reduced notched/unnotched tensile ratios in the transverse direction at all testing temperatures and in the longitudinal direction at -320° and -423° F; low joint efficiencies; low elongations in the base metal and fusion-weld joints; greater amounts of martensite in the base metal (75 to 80 percent as compared to the normal 60 to 65 percent); a larger amount of stringers present in the microstructure (see Figure 108); low static joint efficiencies of complex-welded joints at -423° F (about 60 percent); and decreased resistance to fatigue failure of the complex joints at -423° F.

Examination of the notched/unnotched tensile ratios (Table 5) shows the following. The notched/unnotched tensile ratios obtained from the notched specimen with a K_t of 3.2 indicate a decrease in toughness at -320° F for the longitudinal direction and a decrease in toughness at -423° F for the transverse direction. With a K_t of 6.3, the ratios

indicate a decrease in toughness for both rolling directions at -320° and -423° F. With a K_t of 19, the ratios also indicate low-temperature embrittlement for both directions at -320° and -423° F. The notched/unnotched tensile ratios obtained from each of the notched specimens (K_t of 3.2, 6.3, and 19) indicate that the transverse rolling direction is less tough than the longitudinal direction.

Fusion-weld joint tensile strengths, elongations, and joint efficiencies indicate a large resistance to brittle failure from 78° to -320° F with a decrease in the resistance to brittle failure at -423° F. The test on resistance spot welds is employed in Specification MIL-W-6858A, "Welding, Aluminum, Magnesium, Non-Hardening Steels or Alloys, and Titanium Spot, Seam, and Stitch". As required by the specification, the tensile/shear ratio must not be less than 0.25 for satisfactory spot weldability. Previous data (References 19 and 24) have indicated that when this test is employed at cryogenic temperatures, the results may correlate with fatigue resistance of complex-welded joints (incorporating resistance spot welds).

The results of the notched/unnotched tensile ratios and tensile/shear ratios of individual spot welds seem to indicate that this particular heat of 301 stainless steel is much less resistant to brittle failure at -320° F than at 78° or -100° F, and that the material is as tough at -423° F as it is at -320° F. A cursory examination of the notched tensile data and the tensile behavior (fracture characteristics of the parent metal tensile tests), however, reveals the following information. The notched ($K_t = 3.2$) tensile strengths continue to increase from 78° to -423° F for the longitudinal direction and continue to increase from 78° to -320° F with a decrease from -320° to -423° F for the transverse direction. The notched ($K_t = 6.3$) tensile strengths increase significantly from 78° to -320° F with very little increase from -320° to -423° F for both rolling directions. The notched ($K_t = 19$) tensile strengths remain about the same for both directions at all testing temperatures. An examination of the fractured unnotched tensile specimens and the tensile data show that at -320° F the material serrated (References 24 and 37) and work hardened but did not fracture until very high tensile strengths were reached. Large increases in the tensile strengths and elongations at -320° F are to be noted. The extraordinary high tensile strengths at -320° F cause the notched/unnotched tensile ratios to be quite small (this explains the decrease in the notched/unnotched tensile ratio with the $K_t = 3.2$ specimens at -320° F). Serrations and work hardening also occur at -423° F; however, the specimens fracture in a "premature" failure at one of the serrations before high loads are reached, resulting in a rather small increase in tensile strength (F_{tu}) from -320° to -423° F. Note the very large decrease in elongation from -320° to -423° F and the large increase in yield strength as compared to tensile strength from -320° to -423° F. The notched/unnotched tensile ratios are therefore significantly decreased at -320° F and not at -423° F as a result of this alloy's tensile behavior at cryogenic temperatures.

Critical fracture toughness (K_c) data were obtained at 78° and -320° F on this heat of material. Specimens used were 10 inches long by 4 inches wide and centrally cracked by means of electrical discharge machining. It has been found that reliable and consistent data can be obtained by use of this coupon and that 0.001-inch crack tips can be machined by the electrical discharge method without altering the microstructure of the material. The data obtained are given below:

| <u>Test Temperature (° F)</u> | <u>Direction</u> | <u>K_c</u> | <u>G_c</u> |
|-------------------------------|------------------|-------------------------|-------------------------|
| 78 | Longitudinal | 204 | 1642 |
| 78 | Transverse | 206 | 1432 |
| -320 | Longitudinal | 142 | 747 |
| -320 | Transverse | 109 | 385 |
| -423 | Longitudinal | 146 | 718 |
| -423 | Transverse | 105 | 355 |

The fatigue data show a high degree of resistance to failure at 78° F. An average of 420 cycles to failure were obtained for the longitudinal joint configuration No. 1 (typical joint as used in the Atlas and Centaur vehicles) at a stress level of 95 percent of the material's yield strength. Also, the large number of cycles required to fail the specimen after detection of the first leak indicates a high degree of resistance to crack propagation. Fatigue data on longitudinal joint No. 2 (containing two rows instead of four rows of spot welds on each side of the fusion weld for attachment of a doubler sheet) were nearly the same as for longitudinal joint No. 1 at 78° F. The number of cycles to failure was somewhat less for the transverse joint than for the longitudinal joints at the same stress level/yield strength ratio. Also, there was a fewer number of cycles from the first leak to failure. The evaluation tests (notched data, notched/unnotched tensile ratios, fusion-weld data and crack propagation tests) indicated that the transverse direction was less tough than the longitudinal direction.

At -320° F, the number of cycles to failure at the highest stress level (95 percent of F_{ty} at -320° F) was much less than for the same test conditions at 78° F. However, at the stress level corresponding to 85 percent of F_{ty} the number of cycles to failure was about the same and at the 75 percent of F_{ty} stress level there was an average of 1029 cycles to failure at -320° F as compared to 862 at 78° F. Longitudinal joint No. 2 was less resistant to fatigue failure than longitudinal joint No. 1 at -320° F. Also, the number of cycles to failure for the transverse joints was less than for the longitudinal joints at the same ratios of stress levels to F_{ty} . Although there was a fewer number of cycles to failure at the higher stress levels at -320° F than at 78° F, it is apparent from the fatigue data that this material is still quite tough and resistant to fatigue failure at -320° F. Some of the evaluation tests indicate embrittlement at

-320° F (i. e. tensile/shear ratio of spot welds, notched/unnotched tensile ratios for all notched configurations, and crack propagation data). However, the notched tensile values and fusion-weld tensile properties indicate very little, if any, decrease in toughness at -320° F.

The fatigue data at -423° F show a severe decrease in resistance to brittle failure for both the longitudinal and transverse joints. In fact, the impairment of toughness was so severe that stress levels of 40 to 65 percent of the yield strengths (at -423° F) were used in the fatigue tests. The lower stress levels were mandatory due to the low joint efficiencies (about 60 percent) in static tension tests. The transverse joint was less resistant to fatigue failure than the longitudinal joints. All of the evaluation tests indicate decreased toughness at -423° F; however, the severe embrittlement as shown by the fatigue data was not apparent except for the simple fusion-weld tensile data. In general, it was not felt that the evaluation-type tests provided an adequate quantitative description of the toughness of this particular heat of 301 stainless steel; however, as screening tests, they did indicate a qualitative decrease in toughness at cryogenic temperatures.

This particular heat (49061) of 301 stainless steel was rejected for use in cryogenic tankage and another heat (57644) of material which is more representative of 60-percent cold-rolled 301 stainless steel was evaluated. The tensile and fatigue data obtained on heat 57644 are given in Table 26. It may be seen from the data presented that this heat of 301 retains a much greater resistance to brittle failure at -423° F than did heat 49061.

8.2 304 ELC STAINLESS STEEL. The tensile and fatigue properties of 50-percent cold-rolled 304 ELC stainless steel are given in Tables 6, 14, and 19 and Figures 31 through 65, 69, 70, and 78 through 86. Photographs of fractured tensile and fatigue specimens and microstructures are shown in Figures 104, 109, 116, and 120.

Base metal yield and tensile strengths increased about 50 percent upon reducing the testing temperature from 78° to -423° F but were 26 to 30 percent at -320° F, a result which had been noted in previous tests (References 19 and 24). The elongations at 78°, -100°, and -423° F are primarily due to "necking" whereas at -320° F the elongations are of a uniform nature over the entire reduced section of the tensile specimen. Magnetic measurements indicate that the reduced section of coupons tested at -320° F contains nearly 100-percent martensite whereas reduced sections of coupons tested at 78°, -100°, and -423° F show very little austenite transformation. Fusion-weld joint efficiencies are quite low at 78° F but continuously increase with reduction in testing temperature to values in excess of 90 percent at -423° F. All fractures occurred in the weld or heat-affected zone. Elongations of the weld joints were low at all testing

temperatures but continuously increased with reduction in testing temperature. The weld tensile data indicate that the 304 ELC material does not decrease in toughness to -423°F .

In general, the notched (K_t of 3.2, 6.3, and 19) tensile data and notched/unnotched tensile ratios indicate that the 50-percent cold-rolled Type 304 ELC stainless steel is quite tough from 78° to -423°F . For the notched specimen with a K_t of 3.2, the notched tensile strengths and notched/unnotched tensile ratios continuously increased from 78° to -423°F . For the notched specimens with a K_t of 6.3, the notched tensile strengths continuously increased from 78° to -423°F and the notched/unnotched tensile ratios were considerably above unity at all testing temperatures. With a K_t of 19, the notched tensile strengths continuously increased from 78° to -423°F in the longitudinal direction but decreased from -320° to -423°F for the transverse specimens. Also, the notched/unnotched tensile ratios were much less for the transverse than the longitudinal direction at 78° , -100° , and -423°F . Interpretation of the notched tensile data obtained from specimens with a K_t of 3.2 and 6.3 indicate that this heat of 304 ELC is quite tough at all testing temperatures. The notched ($K_t = 19$) data indicate a high degree of resistance to brittle failure in the longitudinal direction from 78° to -423°F , but a lesser degree of toughness in the transverse direction at 78° , -100° , and -320°F with an indication of embrittlement at -423°F .

Table 14 gives the cross-tensile and tensile-shear properties of individual resistance spot welds at 78° , -100° , -320° , and -423°F . The tension/shear ratios are quite large at all testing temperatures as compared to the 0.25 which is specified as a minimum in MIL-W-6868A. The spot-weld data indicate that the 50-percent cold-rolled 304 ELC material has a high degree of resistance to brittle fracture from 78° to -423°F .

Table 19 presents the fatigue data on complex-welded joints of the 304 ELC stainless steel. As would be expected from the results of notched tensile tests, notched/unnotched tensile ratios, fusion-weld joint efficiencies and tension/shear ratios of resistance spot welds, the number of cycles to failure upon repeated loadings are quite high at all testing temperatures. As may be seen in the table, the stress levels for both longitudinal (parallel to the direction of rolling) and transverse directions were about 85 percent of typical base metal yield strength at each corresponding temperature. Static joint strengths continuously increased from 78° to -423°F with resulting joint efficiencies of nearly 100 percent at all testing temperatures. The number of cycles to failure for the transverse direction is greater than for the longitudinal direction. Although the transverse joint is different than the longitudinal joint, it is believed that the fatigue data show that the 304 ELC material is quite tough to -423°F in both the longitudinal and transverse direction.

It would appear from the data obtained in this investigation that all of the evaluation tests [notched ($K_t = 3.2$ and 6.3) tensile tests, fusion-weld tensile tests, and spot weld tests] , with exception of the notched ($K_t = 19$) data for the transverse direction, properly evaluated the 50-percent cold-rolled Type 304 ELC stainless steel.

8.3 310 STAINLESS STEEL. Mechanical property data on 75-percent cold-rolled Type 310 stainless steel are given in Table 7. Yield and tensile strengths for both the longitudinal and transverse directions increased more than 60 percent from 78° to -423° F. Base metal elongations were greater at all cryogenic temperatures than at room temperature. Fusion-weld joint efficiencies increased from about 45 percent at 78° F to about 70 percent at -423° F, while elongations remained about the same (two percent). Results of the notched tensile testing and notched/unnotched tensile ratios indicate no degree of embrittlement at temperatures down to -423° F for notched specimens with K_t of 3.2 and 6.3. The notched tensile strengths continued to increase from 78° to -423° F and the notched/unnotched tensile ratios were well above unity at all testing temperatures for those specimens with a K_t of 3.2 and 6.3. For the specimens with a K_t of 19, the notched tensile strengths decreased from -320° to -423° F in the longitudinal direction with a resultant decrease in the notched/unnotched tensile ratio at -423° F. Also, the notched ($K_t = 19$) data indicate that the transverse direction is much less resistant to brittle fracture than the longitudinal direction at all testing temperatures.

Cross-tension and tensile-shear strengths of individual resistance spot welds are given in Table 15. As was the case for 304 ELC stainless steel, the 310 material exhibits high tension/shear ratios at all testing temperatures.

The static tensile and fatigue properties of complex-welded joints are presented in Table 20. As may be seen, the static tensile strength continues to increase from 78° to -423° F for both the longitudinal and transverse joints. The fatigue specimens were repeatedly loaded from zero to a stress level of 75, 85, and 95 percent of typical base metal yield strengths at each corresponding temperature. The number of cycles to failure indicate that Type 310 stainless steel is resistant to fatigue failure at all testing temperatures. Longitudinal joint No. 2 (doubler attached by two rows of spot welds on each side of the fusion weld) was somewhat less resistant to fatigue failure than longitudinal joint No. 1 (doubler attached by four rows of spot welds on each side of the fusion weld) at each testing temperature. Also the transverse joints, both No. 1 (overlap roll seam weld with one row of spot welds on each side) and No. 2 (same as longitudinal joint No. 1 except for material direction) joints failed at a lower number of cycles than the longitudinal joints. The fatigue tests were run on transverse joint No. 2 to determine if the material was much less tough for the transverse than for the longitudinal direction. Although there were a fewer number of cycles to failure for the transverse direction, it is believed that the fatigue test data show that the 310 material retains a high degree of resistance to brittle failure for both directions to -423° F.

In general, it is felt that all of the evaluation tests, with the possible exception of the notched ($K_t = 19$) tensile tests, properly evaluated this particular heat of 310 stainless steel.

8.4 AM-355 STAINLESS STEEL. The tensile properties of AM-355 stainless steel, cold-rolled and tempered, are given in Table 8. There is a rather small increase in tensile and yield strengths from 78° to -100° F and then a decrease at -320° and -423° F. Tensile properties of fusion welds indicate poor toughness at -320° and -423° F by the decrease in joint efficiencies and elongations. Notched ($K_t = 6.3$) tensile data indicated a definite decrease in toughness at -320° and -423° F.

The tension/shear ratios of resistance spot welds indicate a lack of toughness at -100°, -320°, and -423° F.

The fatigue data are given in Table 21. The static tensile and fatigue data show that this alloy is relatively brittle even at 78° F. Note that the static tensile failure of the transverse joint was 10,000 psi below the base metal yield strength and that the number of cycles to failure for both the longitudinal and transverse joints was quite small at stress levels of 85 percent of typical yield. The static tensile strengths decreased at -320° and -423° F with resultant joint efficiencies as low as 19 percent. Therefore the fatigue tests had to be run at stress levels of 85 percent of the static joint strengths (or from 17 to 38 percent of the base metal yield strengths) and, even at these low stress levels, only a small number of cycles were obtained prior to failure.

This alloy was included in the investigation to show the correlation of evaluation tests with the axial fatigue (simulated service) data. It was expected that the AM-355 would be quite brittle at cryogenic temperatures due to its high carbon and martensite contents.

The notched tensile strengths, notched/unnotched tensile ratios, tensile properties of the fusion welds, and tension/shear ratios of individual resistance spot welds indicated severe embrittlement of this heat of material at cryogenic temperatures. The low-temperature embrittlement was evidenced by the static tensile and fatigue data of complex-welded joints.

8.5 2014-T6 ALUMINUM ALLOY. The mechanical properties of 2014-T6 aluminum alloy are given in Table 9. Yield and tensile strengths, elongations, proportional limits, and elastic moduli of the base metal continuously increase with decrease in testing temperatures. Hardness values obtained on the reduced sections and fractured edges remain nearly constant over the range of testing temperatures. Tensile strengths of fusion welds (with 2319 aluminum filler) increased from 78° to -423° F with resulting joint efficiencies of 70 to 80 percent. Elongations (over a two-inch gage length) of the welds were small at all testing temperatures and decreased from 78° to -423° F. Typical fractures of base metal and welded tensile specimens are shown in Figure 106.

All fractures of the welded tensile specimens occurred at the edge of the weld in the heat-affected zone. The cored structure of the weld (tested in the "as-welded" condition) may be seen in the photomicrographs of fractured edges shown in Figure 112.

Tensile strengths obtained from the notched tensile specimens having a K_t of 3.2 and 6.3 continuously increased with reduction in testing temperature; however, the notched/unnotched tensile ratios decreased slightly. Notched ($K_t = 19$) tensile strengths decreased from 78° to -320° F and then increased at -423° F for the longitudinal direction, and decreased from 78° to -100° F and then increased at -320° and -423° F for the transverse direction. The notched ($K_t = 19$)/unnotched tensile ratios decreased from 78° to -423° F. The notched tensile and weld tensile tests indicate that there may be a slight decrease in toughness of the 2014-T6 material from 78° to -423° F; however, the decrease would be expected to be quite small.

The fatigue properties of welded joints at 78°, -320°, and -423° F are given in Table 22. Typical fractures of the fatigue specimens are shown in Figures 124 and 125.

Longitudinal and transverse joints No. 1 are simple fusion-welded joints made with 2319 aluminum filler metal. Weld schedules are given in Table 2. Originally it was intended to machine or chemically mill the aluminum fatigue specimens on each side of the weld (such as is shown in Figure 12) to provide a thicker weld area and thus 100-percent joint efficiency; however, a few such specimens were tested with no resulting failures in the weld area. Therefore, the aluminum fatigue specimens were tested without milling in order to obtain failure at the weld and thus provide data on the weld joint. In the design and fabrication of missiles and space vehicles, a thickened weld area would probably be used to provide 100-percent joint efficiency. In this case, the stress on the base metal would be higher than that given in Table 22 (stress range in ksi); however the stress in the weld area would be nearly the same as that given in Table 22. Longitudinal joint No. 2 refers to a joint in which a 0.063-inch doubler sheet (or backing sheet) was fusion welded to the 0.063-inch skins of the specimens (References 20 and 21). A single fusion weld was used to join the skins as well as attach the doubler (no spot welds). This joint was included in the study because of its proposed use as a method of increasing the joint efficiency.

The static tensile strengths of the fatigue specimens increased with decrease in testing temperatures; however, they were smaller than the simple fusion-weld tensile strengths with resulting lower joint efficiencies (60 to 70 percent as compared to 70 to 80 percent for the weld tensile strengths). The fatigue tests were made at stress levels of about 75, 85, and 95 percent of the static joint strengths. These values correspond to about 60 to 70 percent of the base metal yield strengths at each corresponding test temperature. The number of cycles to failure was quite large for the No. 1 joints at 78° F. In fact, nearly all of the specimens either did not fail after 2000 or more cycles or failed in the end plate. Failures in the end plate were a result of the nature of the test equipment which was actually designed to test thinner gage materials having end

doublers for extra strength and bearing surface. All of the test runs are reported in Table 22 and it is believed that the fatigue data show a large resistance to fatigue failure for the No. 1 joints at 78° F. The data obtained on the longitudinal No. 2 joints show poor joint efficiency and poor resistance to fatigue failure at 78° F as well as at -320° and -423° F. Fatigue data on the simple fusion-welded joints (No. 1 joints) at -320° F show a high degree of resistance to fatigue failure at the lower (41.2 and 46.7 ksi) stress levels, but not at the higher stress level (52.2 ksi). Examination of those specimens which fractured at a very low number of cycles (specimens 28L, 26T, 29T, and 30T) showed a fairly large amount of porosity and lack of fusion in the welds which may have been responsible for the poor resistance to fatigue loading. It is believed, however, that the data signify some degree of embrittlement in the weld joint. Fatigue data at -423° F similarly show some degree of embrittlement in the weld joint.

The notched tensile tests and notched/unnotched tensile ratios indicated a slight decrease in toughness from 78° to -423° F and the weld tensile tests showed very little ductility, as determined by elongation, in the welds. As was indicated by the evaluation tests, a partial embrittlement of the fusion welds was evidenced from the fatigue tests at -320° and -423° F. The apparent embrittlement of the 2014-T6 fusion welds seems to be a characteristic of the material. This problem is solved in the design and fabrication of cryogenic pressure vessels by providing a thicker section at the weld and thus reducing the operating stress in the weld area. As may be seen from the data in Table 22, the 2014-T6 welds had a high degree of resistance to fatigue failure at the lower stress levels.

Although the notched tensile tests had previously been used to evaluate the fatigue resistance of complex joints containing spot welds, it is believed that in general, the evaluation tests used (notched and weld tensile) in this investigation performed satisfactorily in properly evaluating the toughness or fatigue resistance of 2014-T6 fusion welds at cryogenic temperatures.

8.6 5052-H38 ALUMINUM ALLOY. The mechanical properties of 5052-H38 aluminum alloy at 78°, -100°, -320°, and -423° F are given in Table 10. The yield and tensile strengths, elongations, proportional limits, and elastic moduli of the parent metal continuously increased with reduction in testing temperature. There was a small increase in the hardness of the reduced sections and fractured edges with decreasing temperature indicating that some work hardening was probably occurring at cryogenic temperatures.

The notched ($K_t = 6.3$) tensile strengths continuously increased from 78° to -423° F, but the notched/unnotched tensile ratios decreased slightly. The tensile strengths, elongations, and joint efficiencies of the fusion-welded tensile specimens continuously increased with reduction in temperature. The evaluation tests indicate that 5052-H38

should remain quite tough to -423° F and that the fatigue resistance of weld joints should be quite high at cryogenic temperatures.

The results of static tensile and axial fatigue testing of fusion-welded (with 5356 aluminum filler) joints of 5052-H38 are given in Table 23. The static tensile strengths continuously increased from 78° to -423° F resulting in joint efficiencies of 70 to 80 percent. Axial fatigue tests were made at stress levels of 85 percent of the static joint strengths. The stress level for the fatigue tests at 78° F corresponded to about 75 percent of the base metal yield strength at the same temperature. At -320° and -423° F the stress levels were 95 to 105 percent of the base metal yield strengths at the corresponding temperatures. Even at these high stress levels, nearly all of the specimens were subjected to 2000 cycles or more without failure. The fatigue data show that 5052-H38 is very tough to -423° F, as would be expected from the notch tensile and weld tensile evaluation tests.

8.7 5456-H343 ALUMINUM ALLOY. Table 11 presents the mechanical properties of 5456-H343 aluminum alloy at 78° , -100° , -320° , and -423° F. Yield and tensile strengths of the base metal continuously increased from 78° to -423° F. Elongations of the base metal increased from 78° to -320° F and then decreased from -320° to -423° F. Proportional limits and elastic moduli increased very little from 78° to -320° F but increased significantly from -320° to -423° F. Hardness values taken at the reduced sections and near the fractured edge remained about the same for specimens tested over the temperature range from 78° to -423° F. Notched ($K_t = 6.3$) tensile strengths increased from 78° to -423° F; however, the notched/unnotched tensile ratios decreased from -100° to -320° F and were considerably less than unity at both -320° and -423° F. Tensile strengths, elongations, and joint efficiencies of fusion welds (with 5356 aluminum filler metal) increased from 78° to -320° F but decreased from -320° to -423° F. The evaluation tests indicate a possible decrease in toughness at -320° F and a definite decrease in toughness at -423° F.

The results of static tensile and axial fatigue tests of large (4-inch by 20-inch test section) fusion-welded specimens are presented in Table 24 and Figures 92 and 93. The No. 2 joint had the same configuration as the No. 2 joint for 2014-T6, and, as was typical for this joint in 2014-T6, proved to be quite poor in fatigue resistance both at room and cryogenic temperatures for the 5456-H343 material. The poor fatigue resistance of this welded joint is believed to be due to the joint configuration and not the material.

The static strengths of the No. 1 joints increased from 78° to -320° F and then decreased at -423° F. The joint efficiencies were 82 percent at 78° F, 84 percent at -320° F, but only 63 to 69 percent at -423° F. The axial fatigue tests were cycled from zero stress to a stress of 85 percent of the base metal yield strength at 78° F (about 90 percent of static joint strength) with no failure occurring after being subjected

to 2000 cycles (other than for two end plate failures). At -320°F , the stress level was 85 percent of the static tensile strength or 93 to 104 percent of the base metal yield strengths at -320°F . There were several fatigue failures in the weld at -320°F ; however, the number of cycles to failure was quite large with respect to the high stress level. The stress level was reduced from 53.7 ksi at -320°F to 47.9 ksi at -423°F due to the decrease in static tensile strength. The 47.9 ksi stress level is 85 percent of the static tensile strength and 75 to 85 percent of the base metal yield strength at -423°F . Except for one specimen (15L), the 5456-H343 fatigue specimens did not fail after being repeatedly cycled from 0 to 47.9 ksi for 2000 cycles at -423°F .

Although there was a decrease in the static tensile strengths and therefore a decrease in the stress levels for the fatigue tests at -423°F , the fatigue data show the 5456-H343 fusion-welded joints are actually quite tough and resistant to fatigue failure at cryogenic temperatures. Further studies, such as crack propagation testing, have been recommended on this alloy to determine if the notched and weld tensile tests have improperly evaluated the material or if the alloy is actually more brittle at -423°F than the fatigue data indicate.

8.8 5A1-2.5Sn TITANIUM ALLOY. The mechanical properties of one heat of annealed Ti-5Al-2.5Sn alloy which was tested at 78° , -100° , -320° , and -423°F are given in Table 12. The yield and tensile strengths of the base metal increase about 100 percent from 78° to -423°F . Elongations decreased with reduction in testing temperature. Proportional limits and elastic moduli continuously increased from 78° to -423°F . Hardness of the reduced sections and fractured edges remained uniform over the range of testing temperatures. Typical fractures and photomicrographs of typical fractures of tensile specimens are shown in Figures 107 and 115.

Notched ($K_t = 3.2$) tensile strengths continuously increased from 78° to -423°F . Although there was a decrease in the notched ($K_t = 3.2$)/unnotched tensile ratios over the same temperature range the values were well above unity even at -423°F . From the mild notched ($K_t = 3.2$) tensile data it would seem that this heat of Ti-5Al-2.5Sn alloy was quite tough from 78° to -423°F . However, the notched tensile data obtained from those specimens with a K_t of 6.3 indicate embrittlement at -423°F , and the notched tensile data obtained from the specimens with a K_t of 19 indicate embrittlement at -320° and -423°F . The notched ($K_t = 6.3$) tensile strengths continuously increase from 78° to -320°F and then decrease from -320° to -423°F . The notched ($K_t = 6.3$)/unnotched tensile ratios are well above unity at 78° , -100° , and -320°F but are significantly decreased at -423°F . Notched ($K_t = 19$) tensile strengths increased from 78° to -100°F but decreased from -100° to -320°F and from -320° to -423°F . The notched ($K_t = 19$)/unnotched tensile ratios were considerably less than unity at -320° and -423°F .

Tensile strengths of fusion-welded (no filler metal) tensile specimens increased from 78° to -423°F with resulting joint efficiencies of 98 to 100 percent at all testing

temperatures. Elongations of the welded tensile specimens, however, decreased slightly from 78° to -320° F and then decreased sharply from -320° to -423° F. The results of the weld tensile data indicate nearly 100 percent joint efficiency from 78° to -423° F but with some degree of embrittlement of the weld at -423° F as witnessed by the decrease in ductility at this temperature and the fact that fractures occurred in the weld area at -423° F (see Figure 107), but in the base metal at 78°, -100°, and -320° F.

The results of cross-tension and tensile-shear tests of individual resistance spot welds are given in Table 17. It may be seen that the shear values are large at all testing temperatures but that the cross-tension values are quite small even at 78° F and decrease at cryogenic temperatures. Therefore, the tension/shear ratios are small at all testing temperatures. The tension/shear ratio is 0.26 at 78° F (a minimum of 0.25 is specified as acceptable in MIL-W-6858A) and 0.16 to 0.19 at cryogenic temperatures. Based on the results of these tests, it would be expected that complex joints, containing resistance spot welds, of this alloy would have marginal fatigue resistance at 78° F and rather poor fatigue resistance at cryogenic temperatures.

The results of static tensile and axial fatigue tests on complex-welded joints of Ti-5Al-2.5Sn alloy are given in Table 25. Static tensile strengths of longitudinal joint No. 1 (doubler attached by four rows of spot welds on each side of the fusion weld) are 120 kis, or 97-percent joint efficiency, at 78° F; 188 ksi, or 95-percent joint efficiency, at -320° F; and 167 ksi, or 67-percent joint efficiency at -423° F. Static tensile strengths of transverse joint No. 1 (overlap of skins with roll-seam weld and one row of resistance spot welds on each side of the seam weld) are 112 ksi, or 91-percent joint efficiency, at 78° F; 158 ksi, or 80-percent joint efficiency, at -320° F; and 159 ksi, or 64-percent joint efficiency at -423° F. The results of the static tensile tests on complex-welded joints show a slight decrease in joint efficiency from 78° to -320° F and a large decrease in joint efficiency from -320° to -423° F. Also, the joint efficiencies for transverse joint No. 1 are less than for longitudinal joint No. 1 at all testing temperatures. The decrease in static tensile strengths and joint efficiencies of the complex-welded joints from -320° to -423° F is felt to be due to the embrittlement of this heat of Ti-5Al-2.5Sn at -423° F and to the poor tensile properties of resistance spot welds. An explanation for the lower joint efficiencies of the transverse joints than for the longitudinal joints is believed to be due to difference in the design of the joints. The transverse joints contain only resistance welds (spot and roll-seam) which were found to have marginal properties at 78° F and inferior properties at cryogenic temperatures, whereas the longitudinal joints contain fusion welds as well as resistance spot welds.

The longitudinal and transverse joints No. 1 were repeatedly loaded from 0 to 87 ksi, 0 to 99 ksi and 0 to 110 ksi at 78° F. These stress levels represent 75, 85, and 95 percent of typical base metal yield strength at 78° F. Also, longitudinal joint No. 2

(doubler attached by two rows of spot welds on each side of the fusion weld) was fatigue tested at 78° F at a stress level of 85 percent of the base metal yield strength, and longitudinal joint No. 3 (simple butt fusion weld with no filler metal, no post weld treatment and no doublers attached) was fatigue tested at stress levels of 85 and 95 percent of the base metal yield strength. Results of these fatigue tests show that each of the joints has a high resistance to fatigue failure at 78° F. Based on the few tests that were made on the butt fusion-welded joint (longitudinal No. 3), it seems that this joint is superior in fatigue resistance to the other joints. This is in accordance with what would be expected from the results of the cross-tension and tensile-shear tests of individual resistance spot welds.

At -320° F the fatigue tests were made at stress levels of 0 to 140 ksi, 0 to 159 ksi, and 0 to 178 ksi which correspond to 75, 85, and 95 percent of the base metal yield strength at -320° F. The results of the fatigue tests at -320° F show that those specimens which contained resistance spot welds (longitudinal joints No. 1 and No. 2 and transverse joint No. 1) were much less resistant to fatigue failure at -320° F than at 78° F (at stress levels of 75, 85, and 95 percent of base metal yield strengths at each corresponding temperature). However, the number of cycles to failure for the butt fusion-welded fatigue specimens (longitudinal joint No. 3) were about the same as for the 78° F tests. Therefore, it is believed that this heat of Ti-5Al-2.5Sn was not embrittled at -320° F, as evidenced by the fatigue data on the butt fusion-welded joints. The poor fatigue resistance of the other joints at -320° F is believed to be due to the presence of the resistance spot welds which were found to have inferior mechanical properties at -320° F.

At -423° F, the fatigue specimens containing resistance spot welds were repeatedly loaded from 0 to 129 ksi, 0 to 146 ksi, and 0 to 163 ksi which correspond to 75, 85, and 95 percent of the static strength of the complex joints or 55, 62, and 70 percent of the base metal yield strengths at -423° F. The stress levels were reduced from the normal 75 to 95 percent of F_{ty} for the fatigue tests at -423° F due to the decreased joint efficiency of the complex joints at this temperature. Even with the reduced stress levels, however, the number of cycles to failure were very small. The stress levels for those fatigue tests made on the simple fusion-welded joints were 0 to 184 ksi and 0 to 208 ksi or 80 and 90 percent of the base metal yield strength at -423° F. The number of cycles to failure was considerably less than those obtained at 78° or -320° F. Also, there was a larger amount of scatter in the fatigue data at -423° F. One fatigue specimen (85L) failed (after 35 cycles) in the base metal at the location of a small scratch. It is believed that the fatigue data indicate that this heat of Ti-5Al-2.5Sn is quite brittle at -423° F as evidenced by the decrease in complex-joint efficiencies and a lower number of cycles to failure for both the complex joints and simple fusion-welded joint.

The notched ($K_t = 3.2$) tensile tests indicated a high degree of toughness to -423°F which was disproved by the fatigue data. The notched ($K_t = 6.3$) tensile tests indicated a high degree of toughness to -320°F but embrittlement at -423°F , which is in accordance with the fatigue test data. The notched ($K_t = 19$) tensile tests indicated embrittlement at -320° and -423°F ; however, it is believed that the fatigue data show embrittlement only at -423°F . The fusion-welded tensile tests indicated a decrease in toughness at -423°F but not at -320°F . From the results of the tests on individual resistance spot welds, a poor performance of those joints containing spot welds would be expected at cryogenic temperatures. It is believed that the notched ($K_t = 6.3$) tensile tests more accurately evaluated the alloy than did the other evaluation tests.

Several heats of the Ti-5Al-2.5Sn alloy have been evaluated at cryogenic temperatures and it has been shown that large amounts of interstitial alloying elements, particularly oxygen, cause this alloy to be brittle at liquid-hydrogen temperatures (References 26, 27, and 38). Therefore a special specification, GD/A-0-71010, which limits the amount of interstitial elements and iron, was prepared. The mechanical properties at 78° , -320° , and -423°F of material purchased to this specification (heat 3930131) were determined and are reported in Table 27. The base metal yield and tensile strengths increase nearly 100 percent from 78° to -423°F . Elongations are high at all testing temperatures. Notched ($K_t = 6.3$) tensile strengths continuously increase from 78° to -423°F and the resulting notched/unnotched tensile ratios are well above unity at all testing temperatures. Simple fusion-weld tensile strengths continuously increase from 78° to -423°F with resulting joint efficiencies of 90 to 97 percent. Elongations of welded specimens were low (1.0 to 2.0 percent) at all testing temperatures. The reason for the low elongations and lower joint efficiencies is due to the presence of a small amount of cold work in the material. All fractures of the weld tensile tests occurred in the weld. Although this heat of Ti-5Al-2.5Sn is believed to be quite tough to -423°F the tension/shear ratios of individual resistance spot welds indicate marginal properties at 78°F and inferior properties at cryogenic temperatures. The low strength of titanium spot welds in cross-tension tests appears to be a characteristic of the material.

The static tensile and fatigue data on complex joints are given in Table 28. As would be expected from the notched ($K_t = 6.3$) tensile data, this heat (3930131) of Ti-5Al-2.5Sn remains quite tough at -423°F as evidenced by the high static tensile strengths and joint efficiencies (81- to 85-percent joint efficiency at -423°F as compared to 64 to 67 percent for heat M-8394) and the relatively large number of cycles to failure.

9 RECOMMENDATIONS FOR FUTURE WORK

The large amount of interest in the properties of engineering materials at cryogenic temperatures is apparent from the increased number of investigations in this field, the large number of recent technical papers in the literature and technical conferences on the properties of materials in a cryogenic environment, and the increased use and growth of the Cryogenic Data Handbook. It is recommended that the work initiated in this investigation be continued to include more materials and more test conditions. The materials and tests recommended for future study are given in Table 30. The crack propagation testing is included to increase the scope of fracture mechanics testing to -423°F and to provide more quantitative data to the metallurgical and design engineers to aid them in the proper selection of materials and the design of structures for cryogenic-fueled missiles and space vehicles. It is also recommended that further investigations be made in the development of statistical analysis methods for evaluating the relative toughness of engineering materials.

Contrails

10 SUMMARY AND CONCLUSIONS

The objectives of this investigation were to develop simple laboratory type tests to evaluate the toughness of high-strength sheet materials at cryogenic temperatures and to obtain useful engineering data on the properties of these materials from 78° to -423°F. Alloys investigated include Types 301, 304 ELC, 310, and AM-355 stainless steels, 2014-T6, 5052-H38, and 5456-H343 aluminum alloys and the 5Al-2.5Sn titanium alloy. The tests employed for evaluating the toughness of sheet alloys included notched ($K_t = 3.2, 6.3, \text{ and } 19$) tensile tests, fusion-weld tensile tests, and cross-tension and tensile-shear tests of individual resistance spot welds. The results from these tests, as well as data obtained from tensile tests of the base metal, and percent martensite, hardness determinations, and metallographic examinations of fractured specimens, were correlated with low-cycle, high-stress fatigue data obtained on complex-welded joints. A total of more than three thousand tensile and fatigue tests were conducted during the investigation, and the data statistically analyzed. The results are presented in tabular and graphical form to aid metallurgical and design engineers in the selection of materials for pressure vessel applications in a cryogenic environment. Based upon the data obtained from the experimental investigation and the information contained within this report the following conclusions are made:

- a. The notched tensile specimen with a stress concentration of 6.3 provided the most reliable and consistent correlation with fatigue resistance (toughness) of complex-welded joints of high strength sheet materials at cryogenic temperatures.
- b. The notched ($K_t = 3.2$) tensile data properly evaluated 304 ELC and 310 stainless steels and 2014-T6 aluminum alloy, but failed to indicate the decreased toughness of 301 stainless steel (heat 49061) and Ti-5Al-2.5Sn alloy (heat M-8394) at -423°F. Due to the mildness of the notch, the data improperly indicated that all of the alloys investigated with the notched ($K = 3.2$) tensile test were resistant to brittle failure at -423°F.
- c. The data obtained from the notched ($K_t = 19$) tensile tests improperly evaluated many of the alloys investigated. These data incorrectly predicted embrittlement of the 301 stainless steel (heat 49061) and the Ti-5Al-2.5Sn alloy (heat M-8394) at -320°F and the 304 ELC (transverse direction) and 310 (transverse direction) stainless steels at cryogenic temperatures.
- d. The fusion-weld tensile data (joint efficiencies and elongation) correlated well with fatigue resistance of welded joints at cryogenic temperatures as compared to the fatigue resistance at 78°F.
- e. The data obtained from cross-tension and tensile-shear tests of individual resistance spot welds provided valuable information for assessing the fatigue resistance of those complex-welded joints which contained spot welds.

- f. The information obtained from a combination of the notched ($K_t = 6.3$) tensile, fusion-weld tensile, and spot-weld tensile and shear evaluation tests provided an accurate evaluation of the low-temperature toughness of the alloys investigated.
- g. Information obtained from statistical analyses (i. e. standard deviations) may provide an index of toughness of materials at cryogenic temperatures.
- h. The data obtained during this investigation are useful to metallurgical and design engineers for the proper selection of materials for, and design of, pressure vessels for application in a cryogenic environment.

The following criteria were used for determining the toughness of each alloy at cryogenic temperatures:

The number of cycles to leak and to failure of welded joints tested in axial fatigue,

Notched/unnotched tensile strength ratios,

Notched tensile strengths as a function of temperature,

Tensile strengths and resulting joint efficiencies of fusion welds as a function of temperature,

The cross-tension/tensile-shear ratio of individual resistance spot welds,

The elongations of parent metal and fusion welded tensile specimens, and

A statistical analysis of the scatter in the test data (i. e. standard deviations).

A fatigue life of 100 cycles at a stress level of 85 percent of the yield strength was considered a minimum for adequate resistance to brittle fracture. Also, a large number of cycles between first crack initiation and final specimen failure was considered desirable since rapid crack extension is a characteristic of brittle behavior. Notched/unnotched tensile strength ratios of 1.0 for a K_t of 3.2, 0.90 for a K_t of 6.3 and 0.60 for a K_t of 19 were considered as minima for acceptable toughness at each test temperature. A decrease of the notched tensile strengths with decrease in temperature was considered to indicate embrittlement; therefore the notched tensile strengths must increase or remain the same with reduction in testing temperature to insure adequate toughness. A large decrease in the tensile strength of butt fusion welds with reduction in testing temperature seemed to indicate an embrittlement of the weld metal. Therefore, only those alloys in which the joint efficiencies of fusion welds remained nearly constant or increased with reduction in temperature were recommended for cryogenic service. An evaluation of the toughness of resistance spot welds was made by the cross-tension/tensile-shear ratio. Whenever this ratio was less than 0.25 the resistance spot weld was considered to be brittle. Although of less significance than the

former evaluation tests, another indication of possible embrittlement was a large decrease in the total elongation of parent or fusion welded metal with decrease in testing temperature. A large amount of scatter in the test data, or large standard deviations as obtained from a statistical analysis of the data, also indicated a lack of toughness. Based on the above criteria and the test data obtained in this program the following materials are recommended for structural applications at cryogenic temperatures.

These materials are sufficiently tough for structural applications at 100° and -320°F: 301 (heats 49061 and 57644), 304 ELC and 310 stainless steels, 2014-T6, 5052-H38, and 5456-H343 aluminum alloys, and Ti-5Al-2.5Sn alloy (heats M-8394 and 3930131).

These materials are sufficiently tough for structural applications at -423°F: 301 (heat 57644), 304 ELC and 310 stainless steels, 2014-T6 and 5052-H38 aluminum alloys, and Ti-5Al-2.5Sn alloy (heat 3930131).

Contrails

11 REFERENCES

1. Hurlich, A., "Properties of Materials at Liquid Oxygen and Liquid Hydrogen Temperatures", Astronautics Report AA-M-23, 15 March 1957.
2. Janis, K., "Bibliography on Low Temperature Characteristics of Steels", International Nickel Company, 1954.
3. Anonymous, "Low Temperature Bibliography for the Field of Cryogenics", (with eight supplements), Engineering Division, A. D. Little Inc. 1958.
4. Anonymous, "Report on Research and Development of Metals and Alloys for low Temperature Applications", Report No. MAB-65-M, Materials Advisory Board, National Academy of Sciences National Research Council, Washington, D.C., 23 April 1954.
5. White, A. E., and Siebert, C. A., Low Temperature Properties of Metals, J. W. Edwards, Ann Arbor, Michigan 1947.
6. Kropschot, R. H., and McCohm, D., "A Bibliography on the Effect of Low Temperature on the Mechanical Properties of Materials" National Bureau of Standards Report 5058, 1957.
7. Seigle, L., and Brick, R. M., "Mechanical Properties of Metals at Low Temperatures: A Survey", Trans. ASM, 40, 1948, p. 813.
8. Teed, P. L., The Properties of Metallic Materials at Low Temperatures, John Wiley Company, New York, N.Y., 1950.
9. Anonymous, "Mechanical Properties of Metals at Low Temperatures", National Bureau of Standards Circular 520, 7 May 1952.
10. Barrett, C. S., "Metallurgy at Low Temperatures", Trans. ASM, 50, 1957, p. 53.
11. DeHaas, W. J., and Hadfield, R. A., "Effect of the Temperature of Liquid Hydrogen (-252.8°C) on the Tensile Properties of Forty-One Specimens of Metals Comprising (a) Pure Iron 99.85% (b) Four Carbon Steels (c) Thirty Alloy Steels (d) Copper and Nickel (e) Four Non-Ferrous Alloys", Philosophical Trans., 232, 1933, Ser. A., p. 297.
12. Watson, J. F., "Properties of Engineering Materials at Extreme Subzero Temperatures with Supplementary Information of Liquid Hydrogen", Astronautics Report MRG-44, 8 December 1958.
13. Brick, R. M., Low, J. R., and Lorig, C. H., Behavior of Metals at Low Temperatures, American Society for Metals, Cleveland, Ohio, 1953.
14. Lorig, C. A., "A Metallurgist Looks at Fracture", Trans. ASM, 44, 1952, p. 30.

15. Anonymous, Fracture of Metals, American Society for Metals, Cleveland, Ohio, 1948.
16. Schaller, F. W., and Zackey, V. F., "Low Temperature Embrittlement of Austenitic Cr-Mn-N-Fe Alloys", Preprint No. 109, ASM, 1958.
17. Buhr, R. K., Gertsman, S. L., and Reeksie, "Transformation Products in Cold Worked Austenitic Stainless Steel", Trans, ASM, 49, 1957, p. 706.
18. Micanoff, D., "Some Aspects of Strain Hardenability of Austenitic Manganese Steel", Trans. ASM, 31, 1943, p. 716.
19. Watson, J. F., and Christian, J. L., "Low-Temperature Properties of Cold-Rolled AISI Types 301, 302, 304 ELC, and 310 Stainless Steel Sheet", Symposium on Low Temperature Properties of High Strength Aircraft and Missile Materials, ASTM Special Publication No. 287, pp. 170-195, June 1960.
20. Christian, J. L., et al., "A Proposal for the Development of Tests to Evaluate the Toughness of High-Strength Sheet Alloys and the Fatigue Resistance of Welded Joints at Cryogenic Temperatures", Astronautics Report No. AE60-0707, 29 August 1960.
21. Christian, J. L., "Physical and Mechanical Properties of Pressure Vessel Materials for Application in a Cryogenic Environment", 1st Quarterly Progress Report on Contract AF33(616) -7719, 1 March 1961.
22. Christian, J. L., "Physical and Mechanical Properties of Pressure Vessel Materials for Application in a Cryogenic Environment", 2nd Quarterly Progress Report on Contract AF33(616) -7719, 1 June 1961.
23. Christian, J. L., "Physical and Mechanical Properties of Pressure Vessel Materials for Application in a Cryogenic Environment", 3rd Quarterly Progress Report on Contract AF33(616) -7719, 1 September 1961.
24. Watson, J. F. and Christian, J. L., "The Effect of Cryogenic Temperatures on the Mechanical Properties of High Strength Sheet Alloys (Cold Worked Austenitic Stainless Steels)", Astronautics Report No. ERR-AN-003, 16 May 1960.
25. Watson, J. F., et. al., "The Correlation of Notch: Unnotch Tensile Ratios with Tensile Fatigue Properties of Complex Welded Joints in High Strength 300 Series Stainless Steels at Cryogenic Temperatures", Presented at the annual meeting of the American Society for Testing Materials, Atlantic City, New Jersey, June 1961.
26. Christian, J. L. and Chafey, J. E., "Determination of the Effect of Iron and Oxygen Contents on the Mechanical Properties of Titanium 5Al-2.5Sn Alloy Sheet at Liquid Hydrogen Temperature (-423°F)", Astronautics Report No. MRG 262, October 1961.

27. Christian, J. L., "Determination of the Effect of Oxygen Content on the Mechanical Properties of Ti-5Al-2.5Sn Alloy at Room and Cryogenic Temperatures", Astronautics Report No. MRG-266, October 1961.
28. Peterson, R. E., Stress Concentration Design Factors, Appendix A, John Wiley & Sons, Inc., 1953, pp 136-138.
29. Neuber, Heinz, Theory of Notch Stresses, English Translation, J. W. Edwards, Ann Arbor, Michigan, 1946.
30. Christian, J. L., and Watson, J. F., "Cryostat and Accessories for Tensile Testing at -423°F", Materials, Research and Standards, ASTM, Vol, 1. No. 2, February 1961.
31. Witzell, W. E., "An Introduction to Crack Propagation in High Strength Sheet Materials", Astronautics Report No. MRG-286, January 1962.
32. Watson, J. F. and Christian, J. L., "A Study of Austenite Decomposition at Cryogenic Temperatures", Astronautics Report No. ERR-AN-057, 9 June 1961.
33. Special ASTM Committee "Fracture Testing of High Strength Sheet Materials", ASTM Bulletin, January 1960.
34. MIL-HDBK-5, Strength of Metal Aircraft Elements, March 1959.
35. Bennett, C. A. and Franklin, N. L., Statistical Analysis in Chemistry and the Chemical Industry, John Wiley and Sons, Inc., 1954.
36. Schumacher, J. G., "Statistical Determination of Strength Properties", Astronautics Report No. AZS-27-274A, 11 November 1948.
37. Watson, J. F. and Christian, J. L., "Serrations in the Stress-Strain Curve of Cold Worked 301 Stainless Steel at 20°K", Journal of the Iron and Steel Institute, August 1960.
38. Christian, J. L., "Mechanical Properties of Titanium and Titanium Alloys at Cryogenic Temperatures", Astronautics Report No. MRG-189, 14 October 1960.

Contrails

Contrails

ILLUSTRATIONS

Contrails

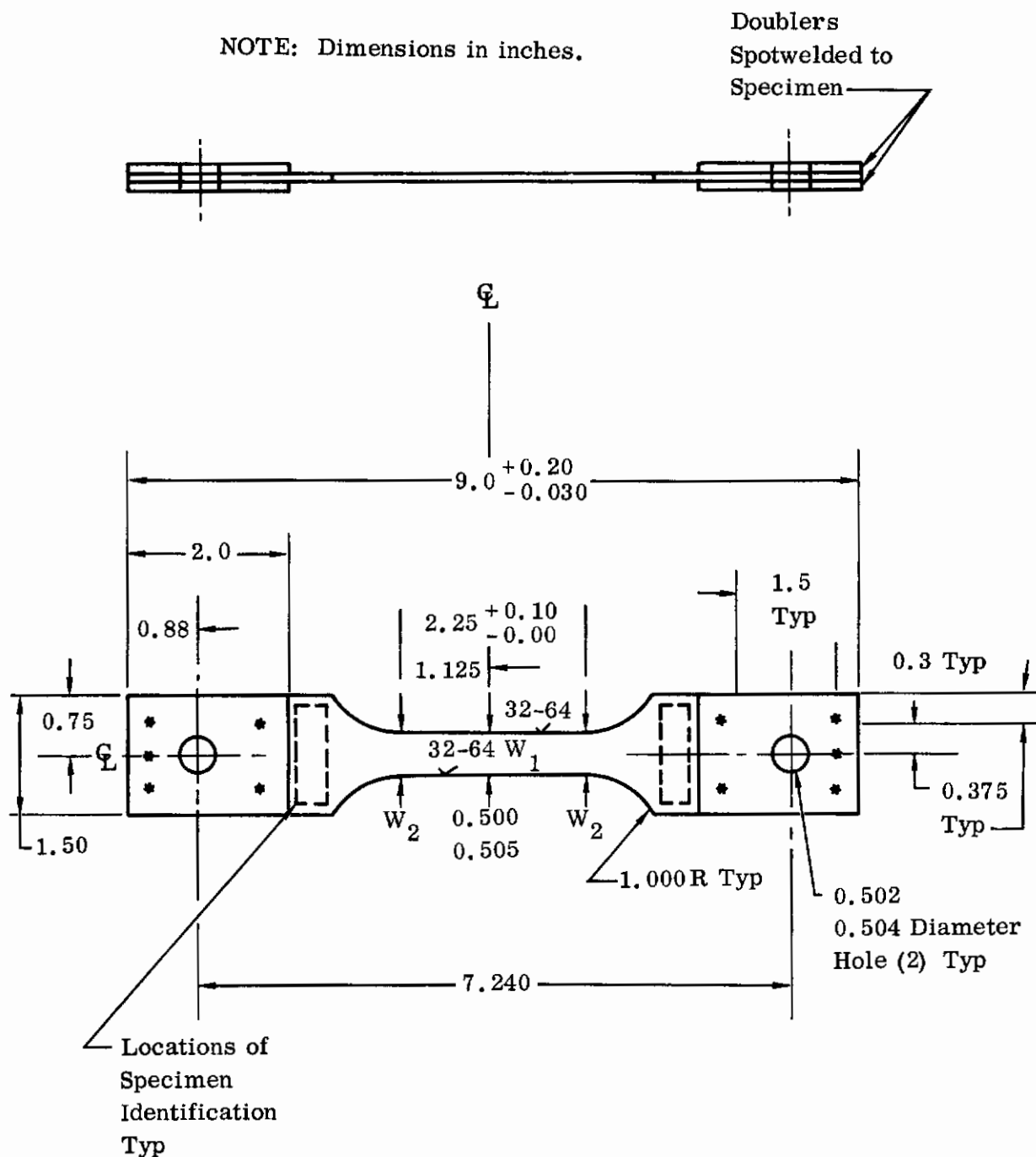
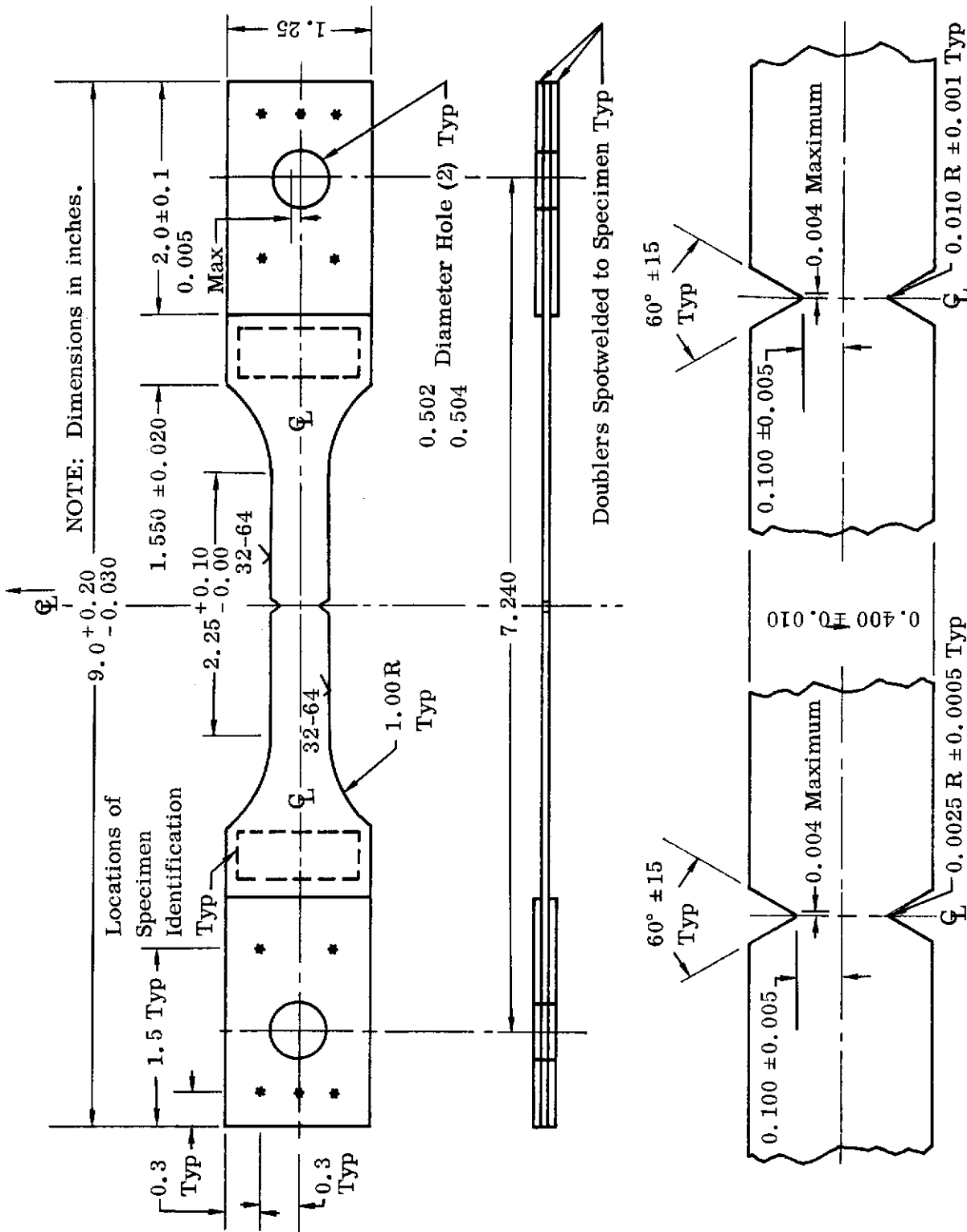

Figure 1. Flat Tensile Specimen (Standard)



TYPE "A" NOTCH - $\frac{A}{R} = 40$ (32-52)

TYPE "B" NOTCH - $\frac{A}{R} = 10$ (8.6-11.1)

Figure 2. Notched Tensile Specimen ($K_t = 3.2$ and 6.3)

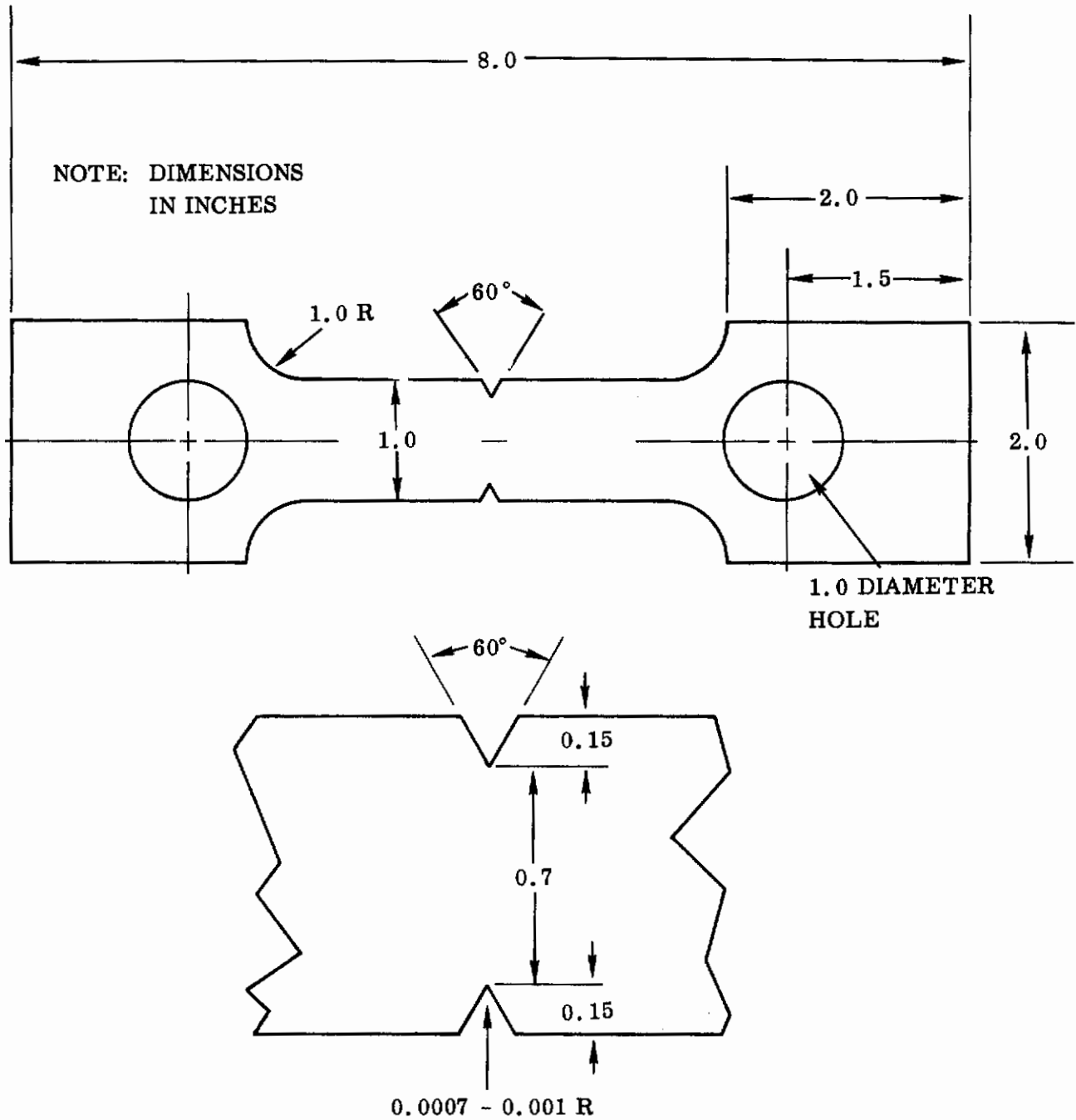

Figure 3. Notched Tensile Specimen ($K_t = 19$)

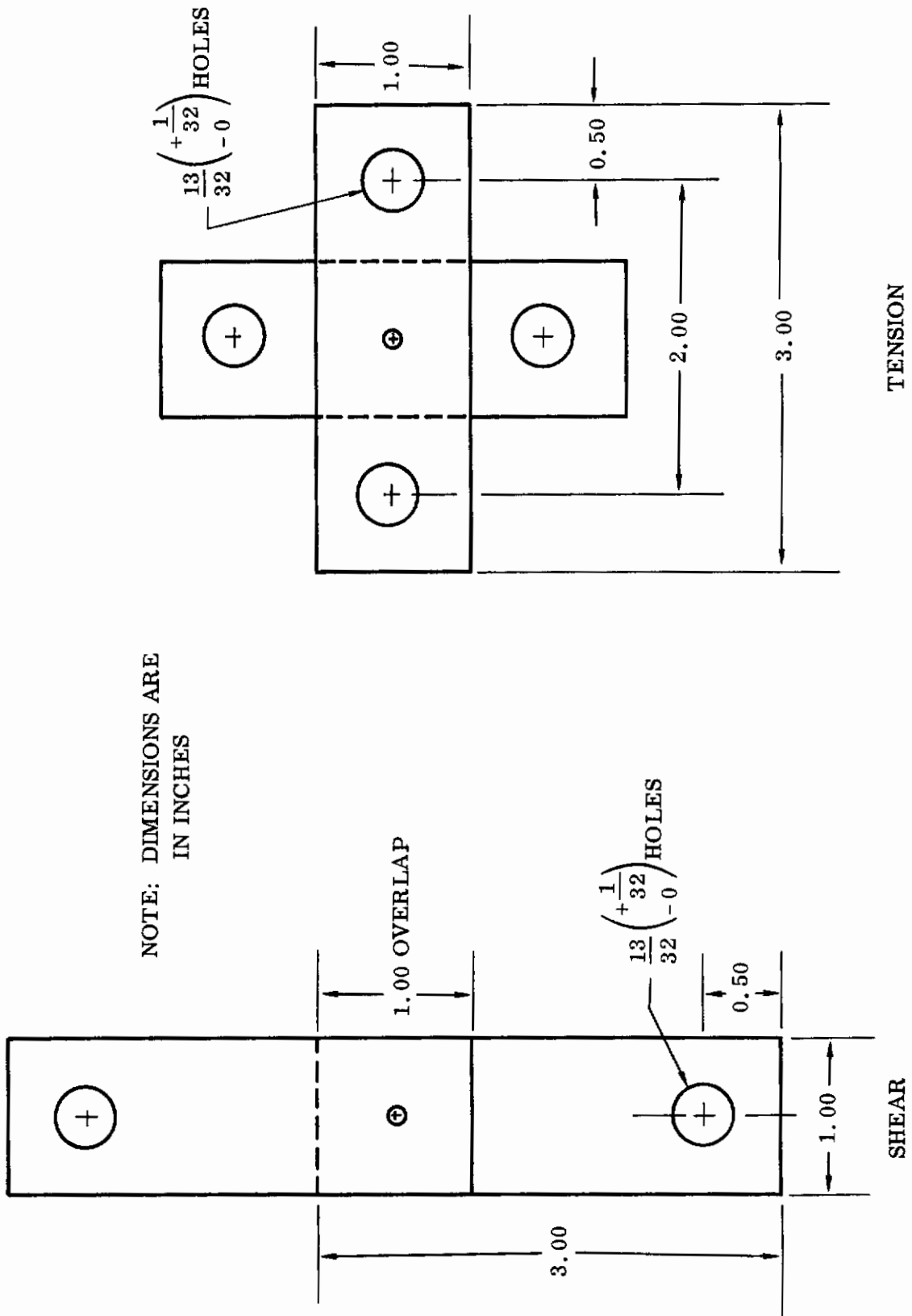
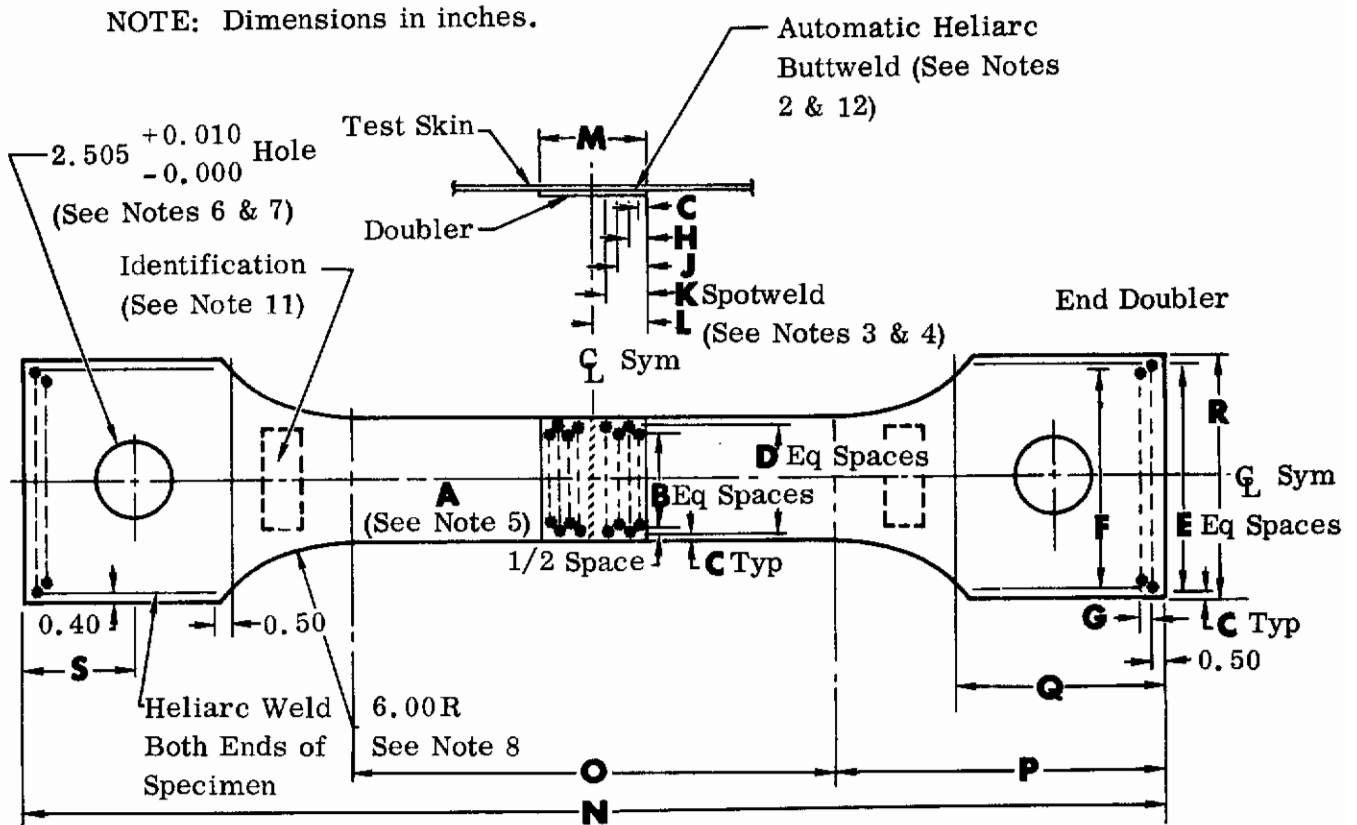

Figure 4. Spot Welded Tension and Shear Specimens



| MATERIAL | ASSY | A | B | C | D | E | F | G | H | J | K | L | M | N | O | P | Q | R | S |
|------------------|------|------|---|------|---|----|----|------|------|------|------|------|------|----|----|----|---|---|------|
| 301 SS | -855 | 4.52 | 7 | 0.32 | 8 | 11 | 10 | 0.37 | 0.74 | 1.14 | 1.52 | 2.00 | 3.51 | 38 | 16 | 11 | 7 | 8 | 3.75 |
| Ti and AM-355 SS | -843 | 4.26 | 5 | 0.34 | 6 | 11 | 10 | 0.37 | 0.74 | 1.14 | 1.52 | 2.00 | 3.51 | 38 | 16 | 11 | 7 | 8 | 3.75 |
| 310 SS | -837 | 3.98 | 6 | 0.25 | 7 | 13 | 12 | 0.34 | 0.59 | 0.93 | 1.27 | 1.74 | 3.51 | 38 | 16 | 11 | 7 | 8 | 3.75 |
| 304 SS | -825 | 3.86 | 7 | 0.25 | 8 | 17 | 16 | 0.34 | 0.59 | 0.93 | 1.27 | 1.74 | 3.51 | 38 | 16 | 11 | 7 | 8 | 3.75 |

1. Metal stamping of parts not permitted.
2. Butt weld test skins prior to machining.
3. Spot welds per spec MIL-W-6858A.
4. Tolerance on location of spot welds to be ± 0.06 .
5. Test section width minimum at center. Total taper to be 0.010 from one end to center.
6. Edges of skin must be sharp and free from burrs.
7. Holes to be centered with test section ± 0.015 .
8. In radius no notches or undercuts permitted.
9. Material spec to be called out with specimen request.
10. Edges of test skin to be machined to $125\sqrt{\text{finish}}$.
11. Each specimen to have gage, coil, heat, spec and specimen number.
12. Heliarc butt welds per spec 0-75005.

Figure 5. Fatigue Specimen (Longitudinal for Steel and Titanium)

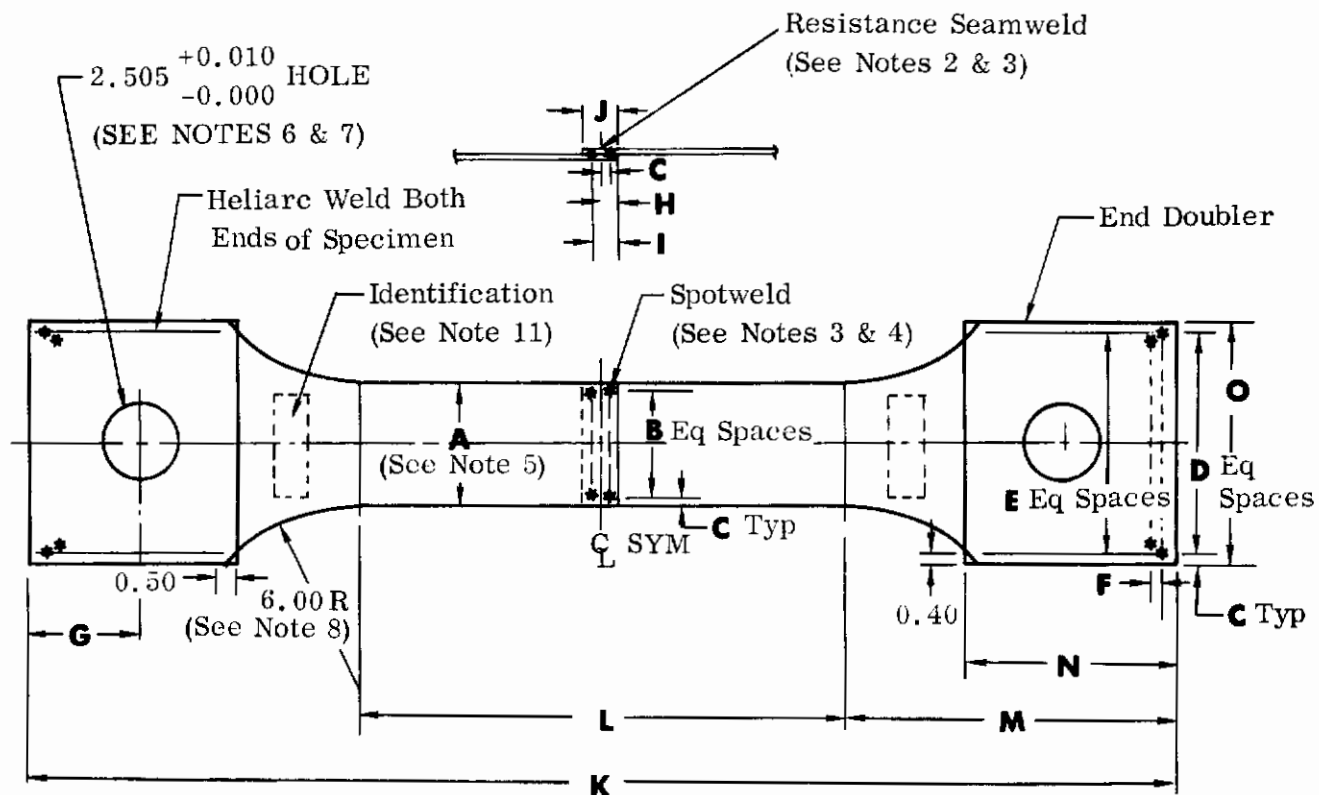

Note: Dimensions in inches.

| MATERIAL | ASSY | A | B | C | D | E | F | G | H | I | J | K | L | M | N | O |
|---------------|------|------|---|------|----|----|------|------|------|------|------|------|----|----|---|---|
| 304SS | -845 | 3.86 | 8 | 0.25 | 17 | 16 | 0.34 | 3.75 | 0.59 | 0.93 | 1.21 | 38.0 | 16 | 11 | 7 | 8 |
| 310SS | -857 | 3.98 | 6 | 0.25 | 12 | 11 | 0.34 | 3.75 | 0.59 | 0.93 | 1.21 | 38.0 | 16 | 11 | 7 | 8 |
| Ti and AM-355 | -859 | 4.12 | 6 | 0.28 | 13 | 12 | 0.37 | 3.75 | 0.71 | 1.14 | 1.42 | 38.0 | 16 | 11 | 7 | 8 |
| 301SS | -861 | 3.92 | 6 | 0.28 | 13 | 12 | 0.37 | 3.75 | 0.65 | 1.02 | 1.33 | 38.0 | 16 | 11 | 7 | 8 |

1. Metal stamping of parts not permitted.
2. Seamweld test skins prior to machining.
3. Spotwelds and seamweld per MIL-W-6858A.
4. Tolerance on location of spotwelds to be ± 0.06 .
5. Test section width minimum at center. Total taper to be 0.010 from one end to center.
6. Edges of skin must be sharp and free from burrs.
7. Holes to be centered with test section ± 0.015 .
8. In radius no notches or undercuts permitted.
9. Material spec to be called out with specimen request.
10. Edges of test skin to be machined to $\sqrt{125}$ finish.
11. Each specimen to have gage, coil, heat, spec and specimen number.

Figure 6. Fatigue Specimen (Transverse for Steel and Titanium)

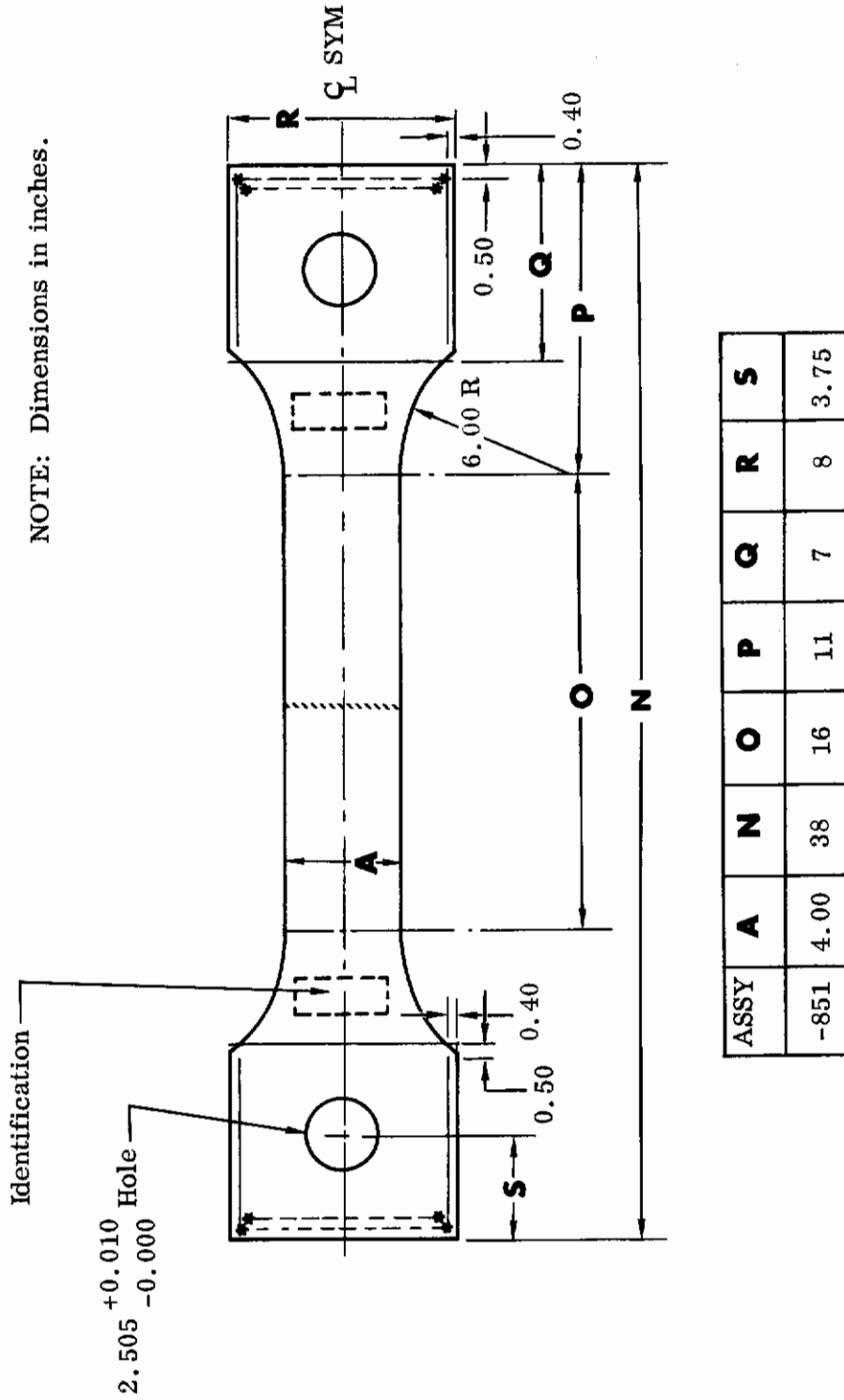

Figure 7. Fatigue Specimen (Longitudinal and Transverse for Aluminum)

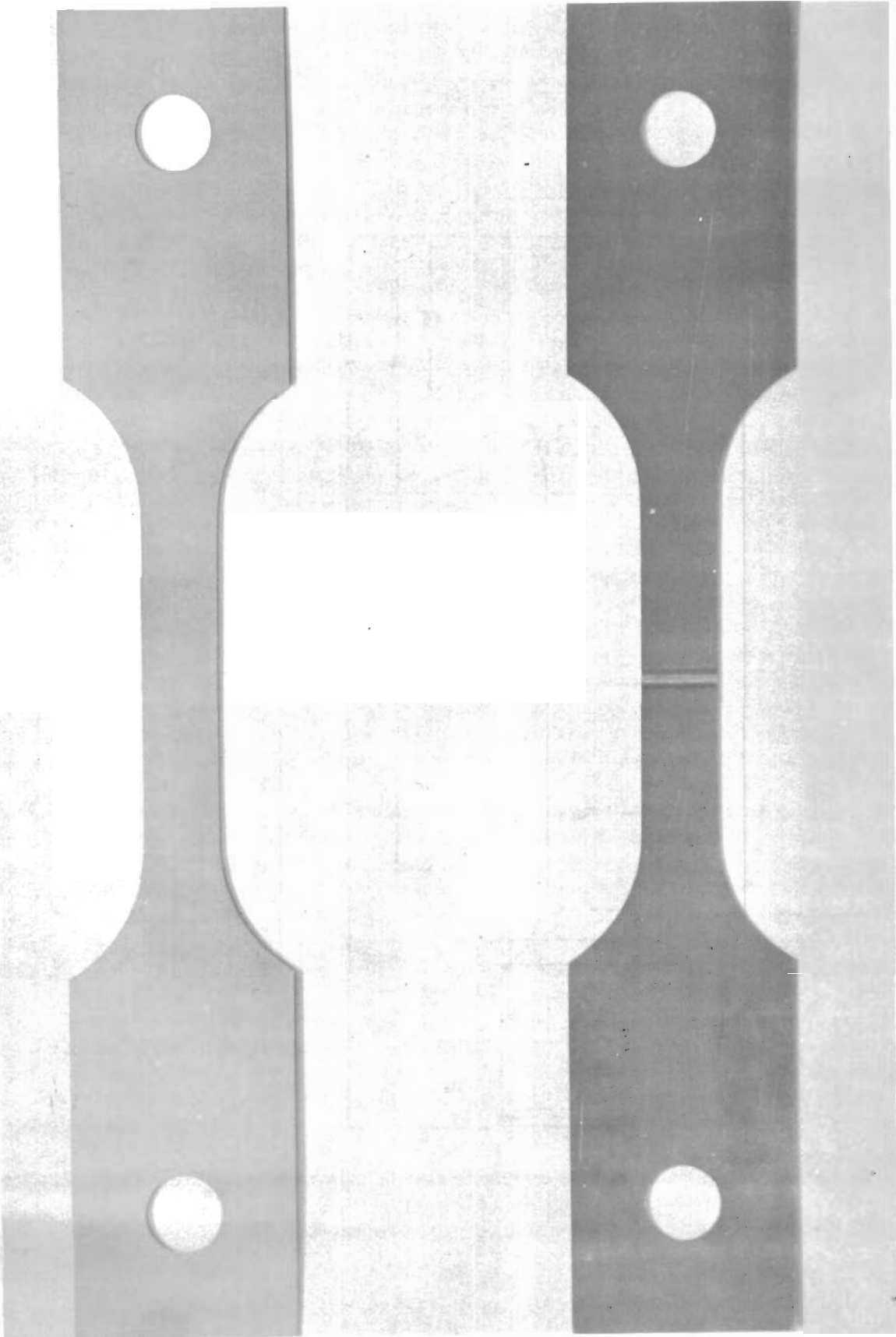

Figure 8. Photograph of Parent Metal and Welded Flat Tensile Specimens

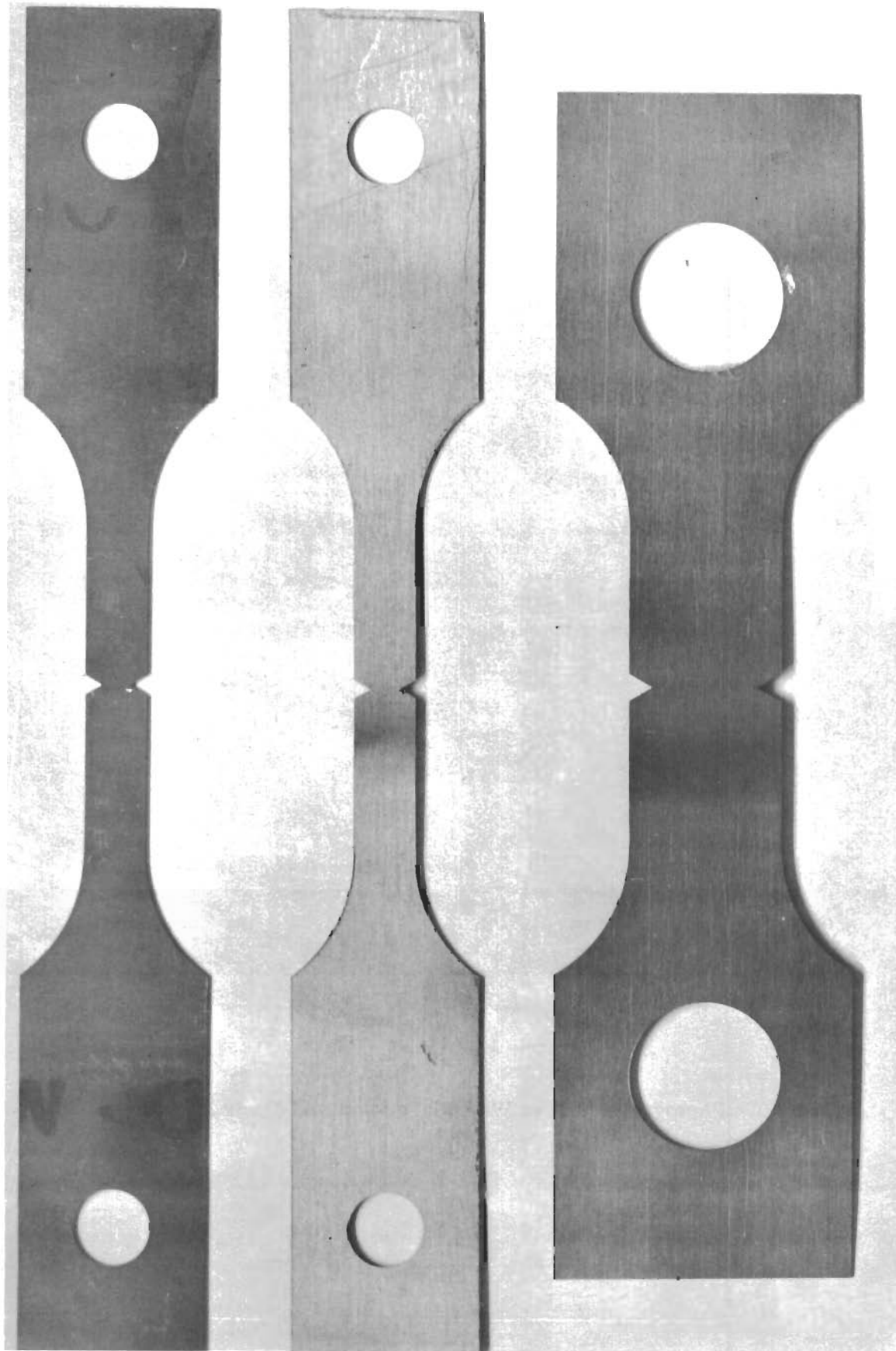

Figure 9. Photograph of Notched Tensile Specimens

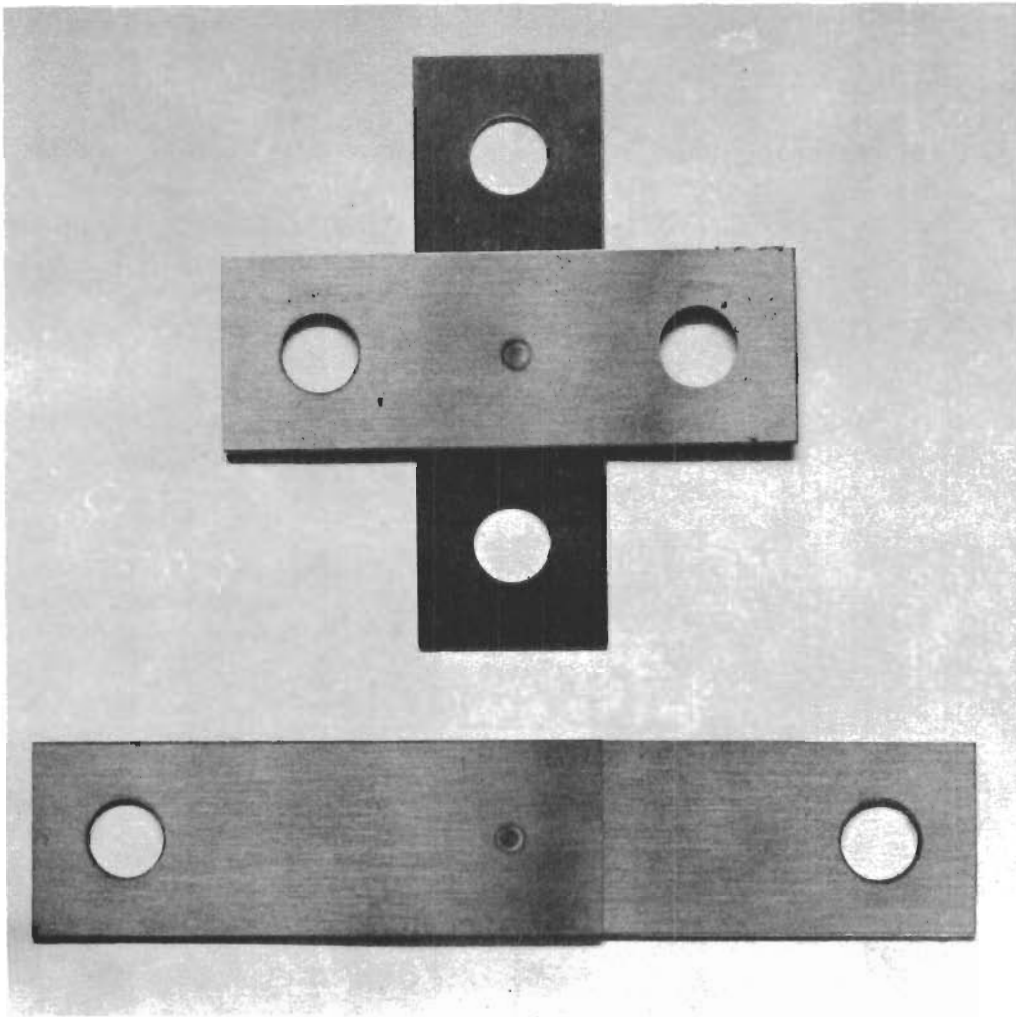

Figure 10. Photograph of Spot Welded Tension and Shear Specimens

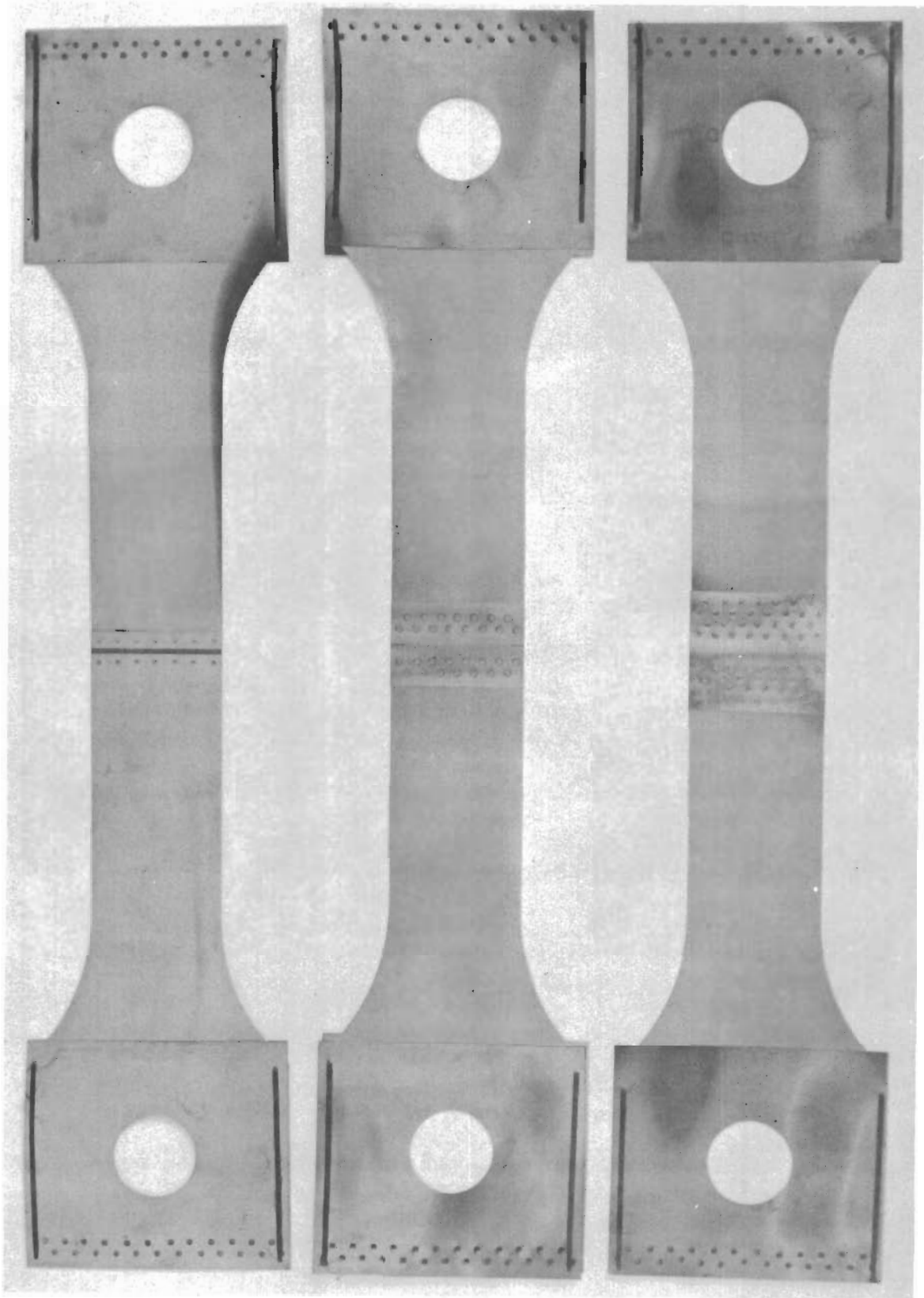

Figure 11. Photograph of Fatigue Specimens (Steel and Titanium)

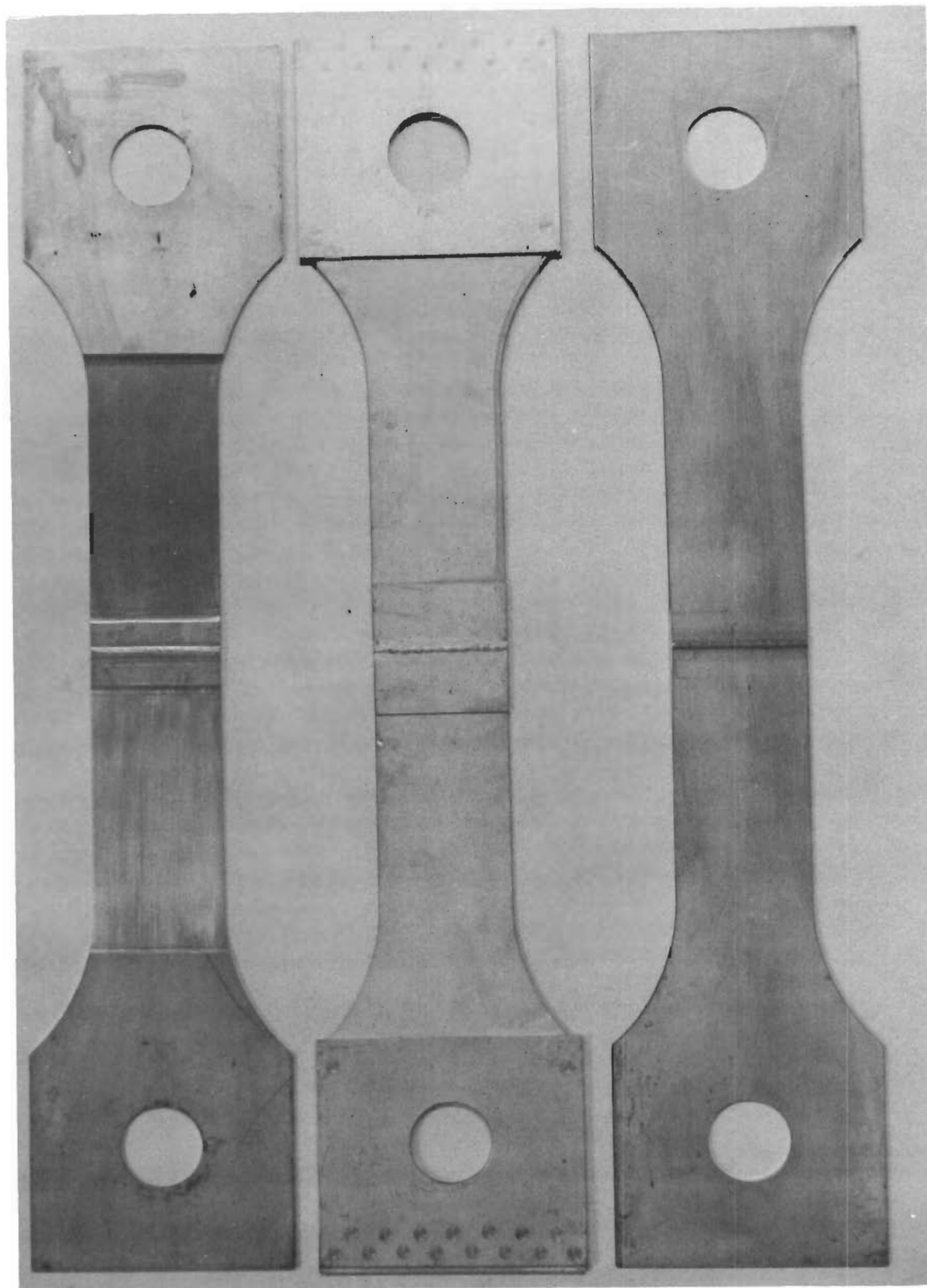

Figure 12. Photograph of Fatigue Specimens (Aluminum)

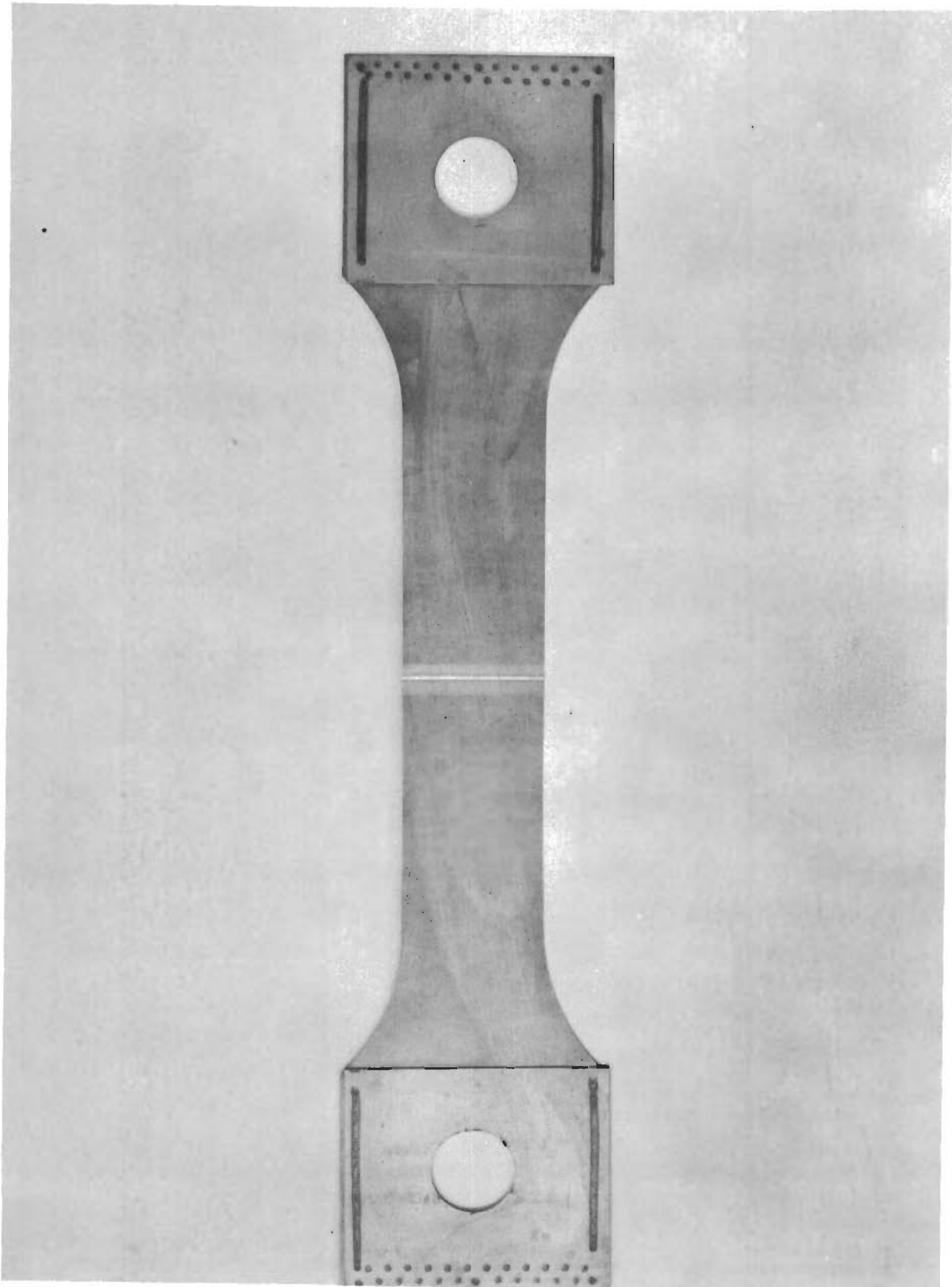

Figure 13. Photograph of Fatigue Specimen (Titanium)

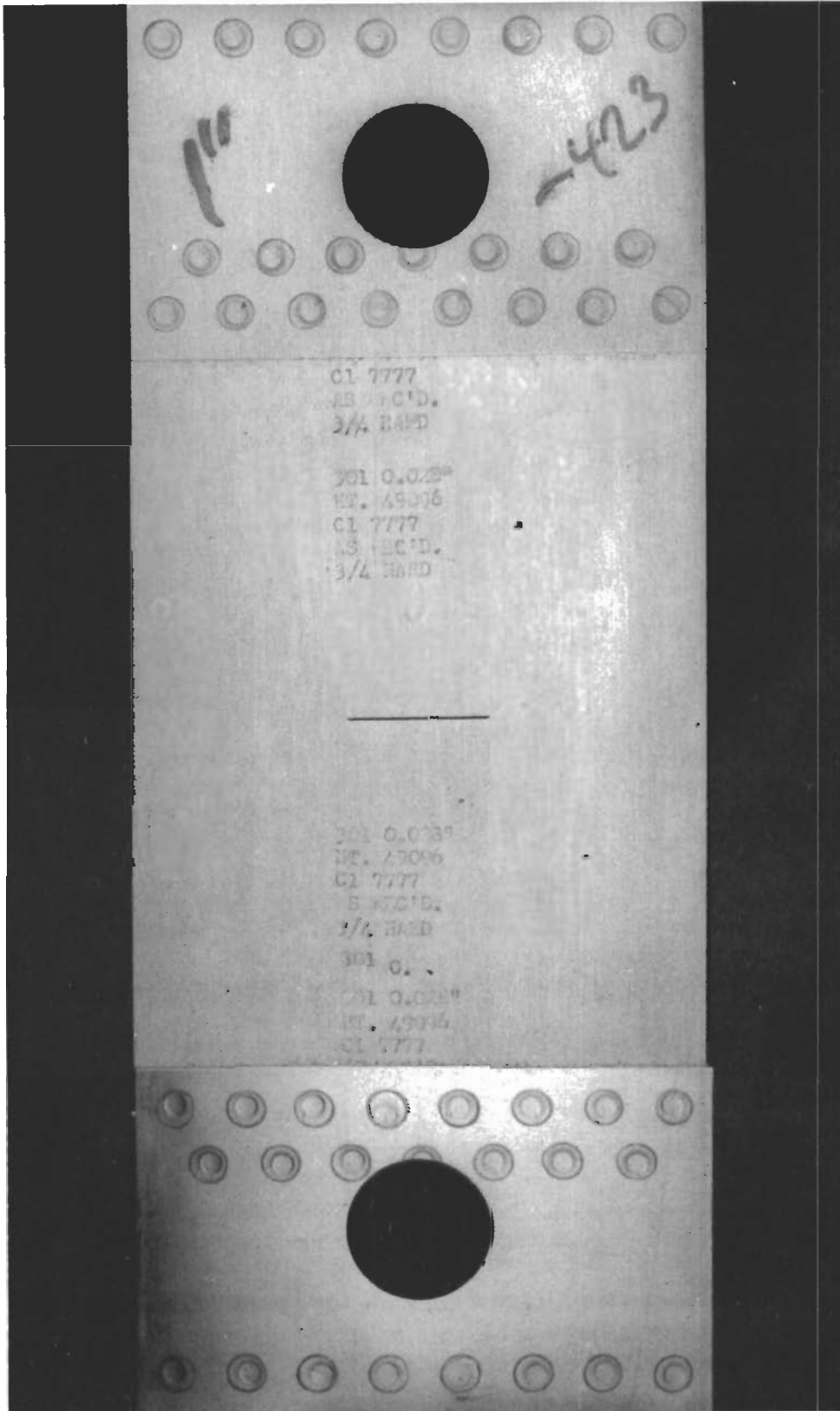

Figure 14. Photograph of Crack Propagation Specimen

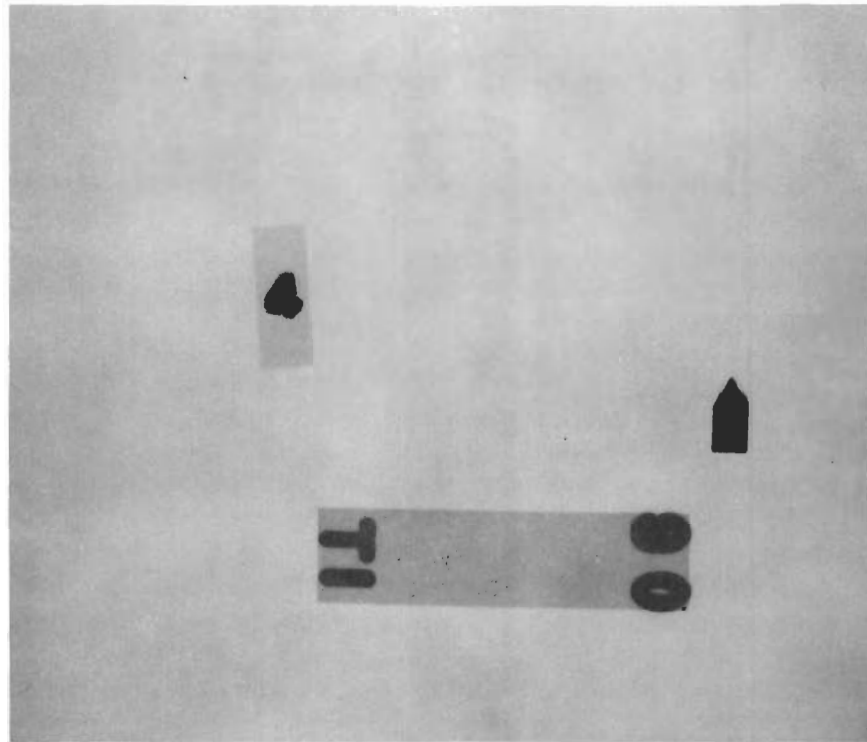

Figure 15. Radiograph of Fusion Welded Fatigue Specimen



Figure 16. Radiograph of Complex Welded Fatigue Specimen

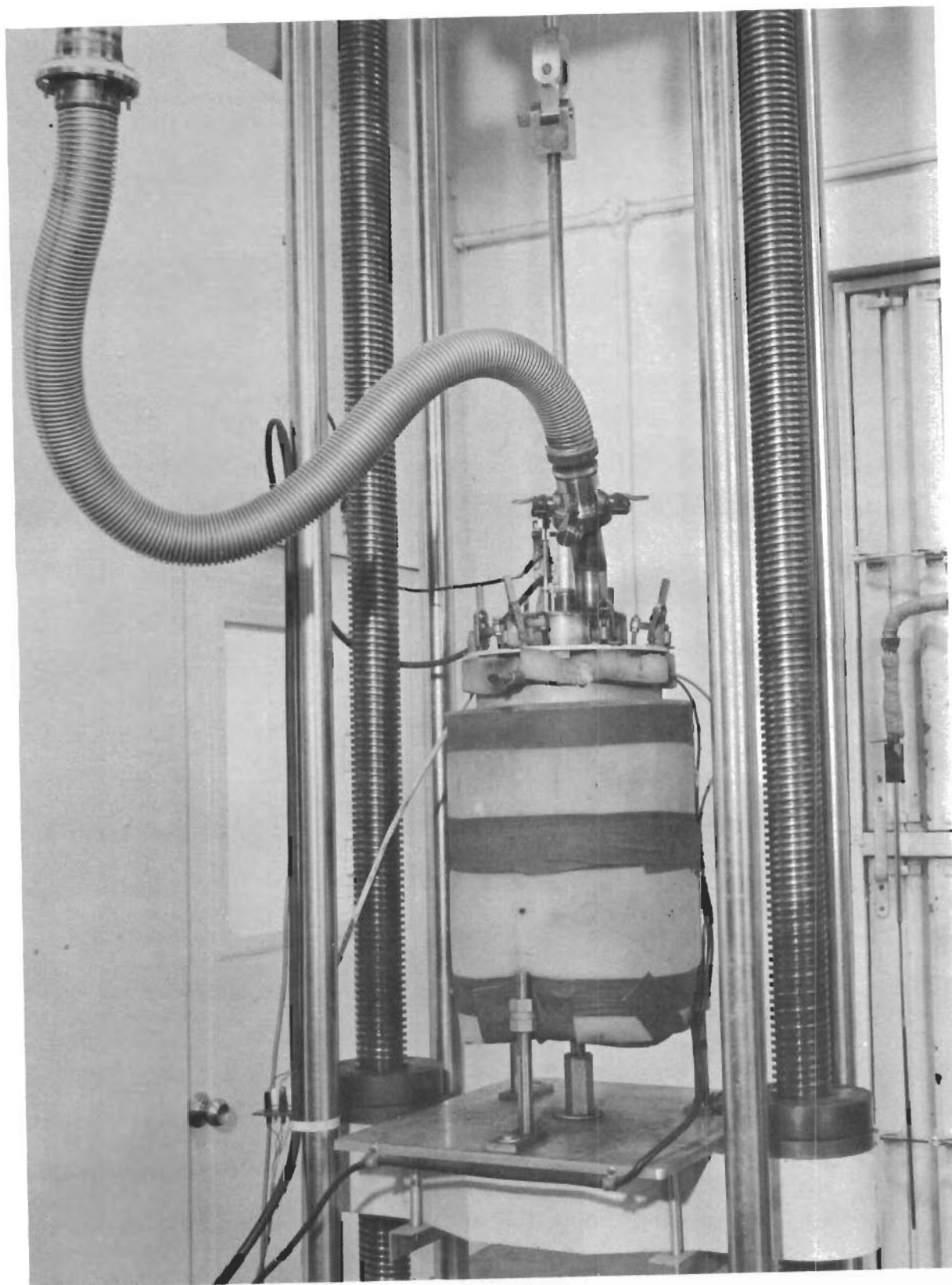

Figure 17. Liquid-Hydrogen Cryostat



Figure 18. Liquid-Hydrogen Test Chamber Being Prepared for Test



Figure 19. Transfer of Liquid Hydrogen

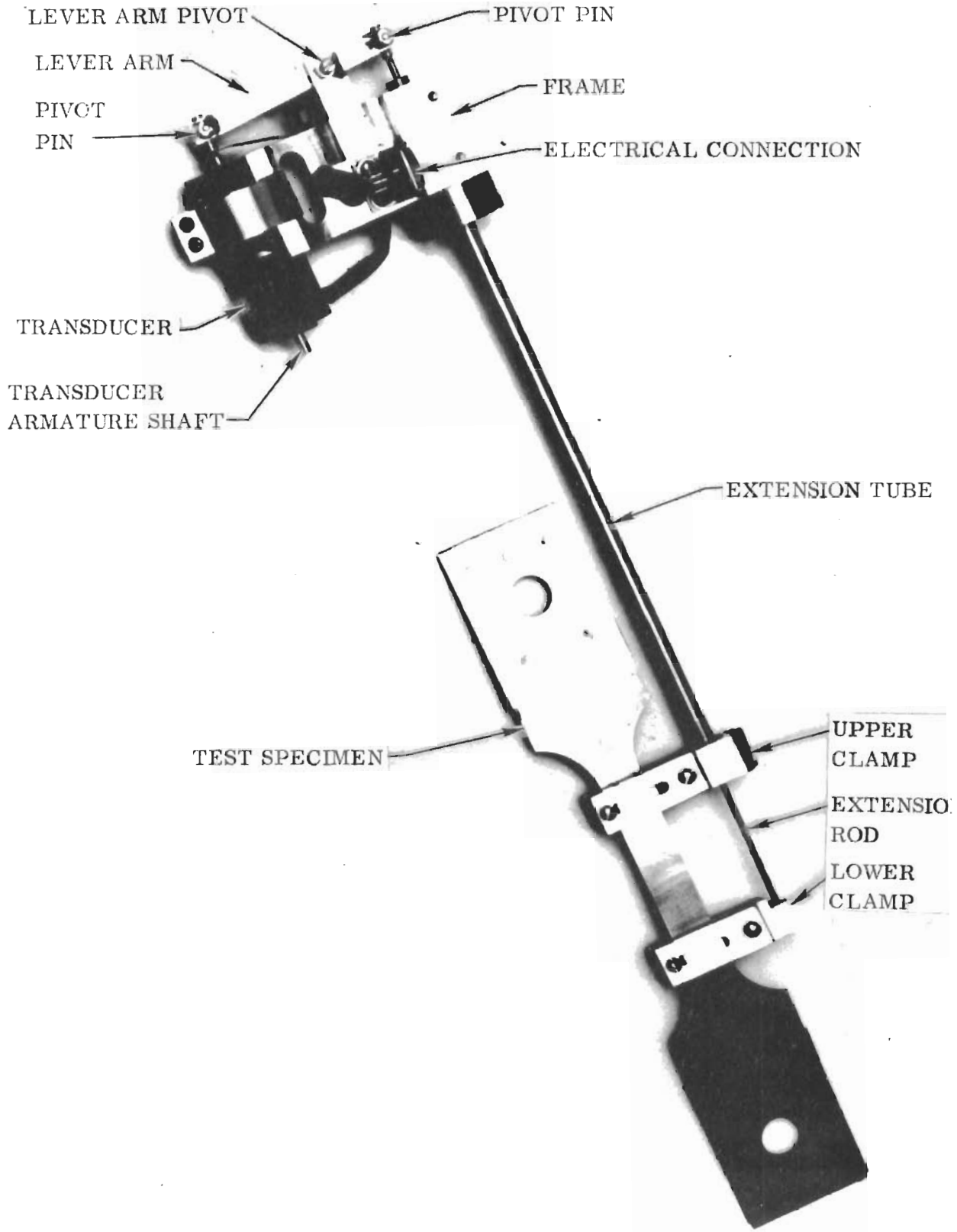

Figure 20. Cryo-extensometer

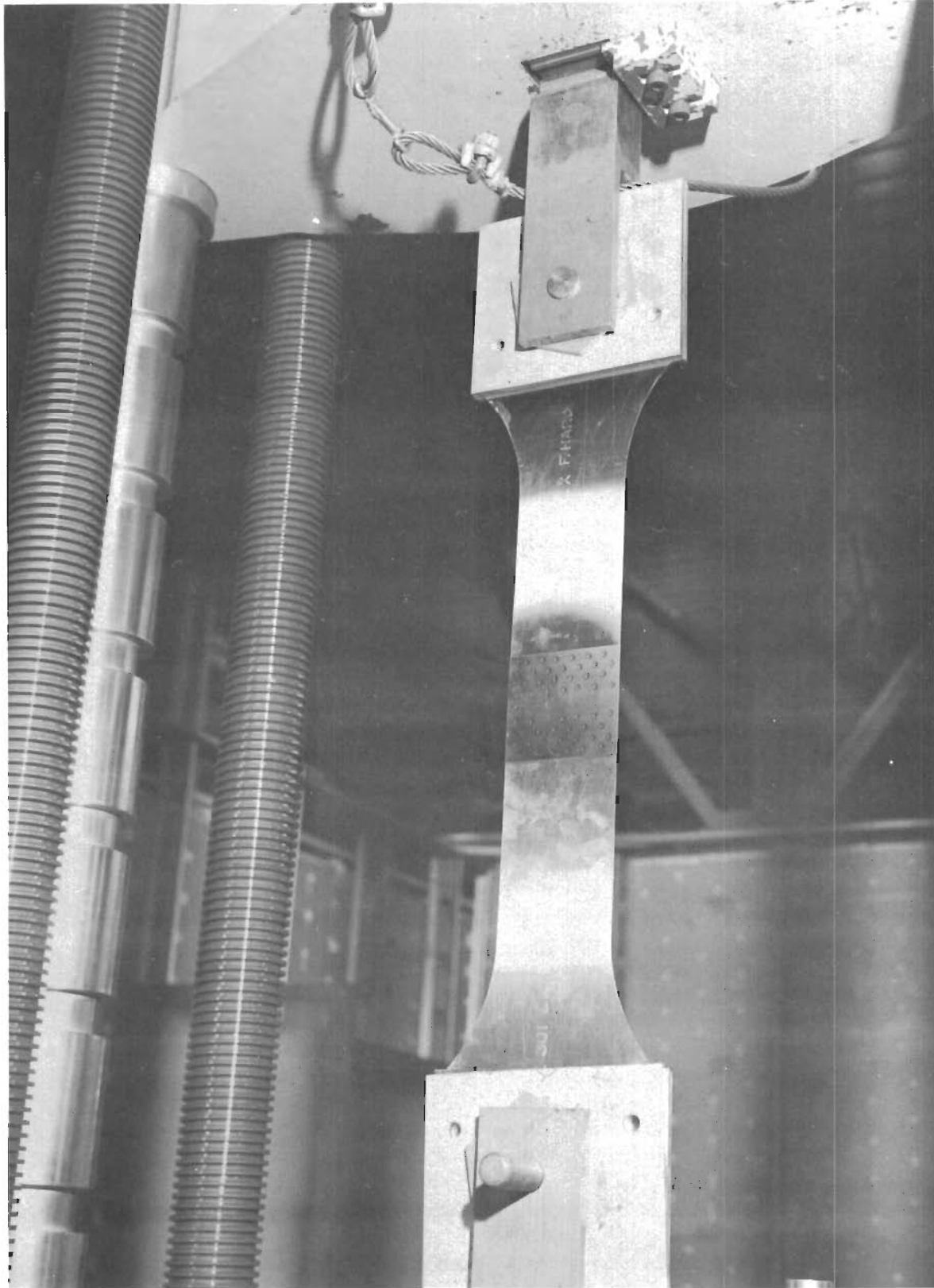

Figure 21. Fatigue Specimen in Static Test

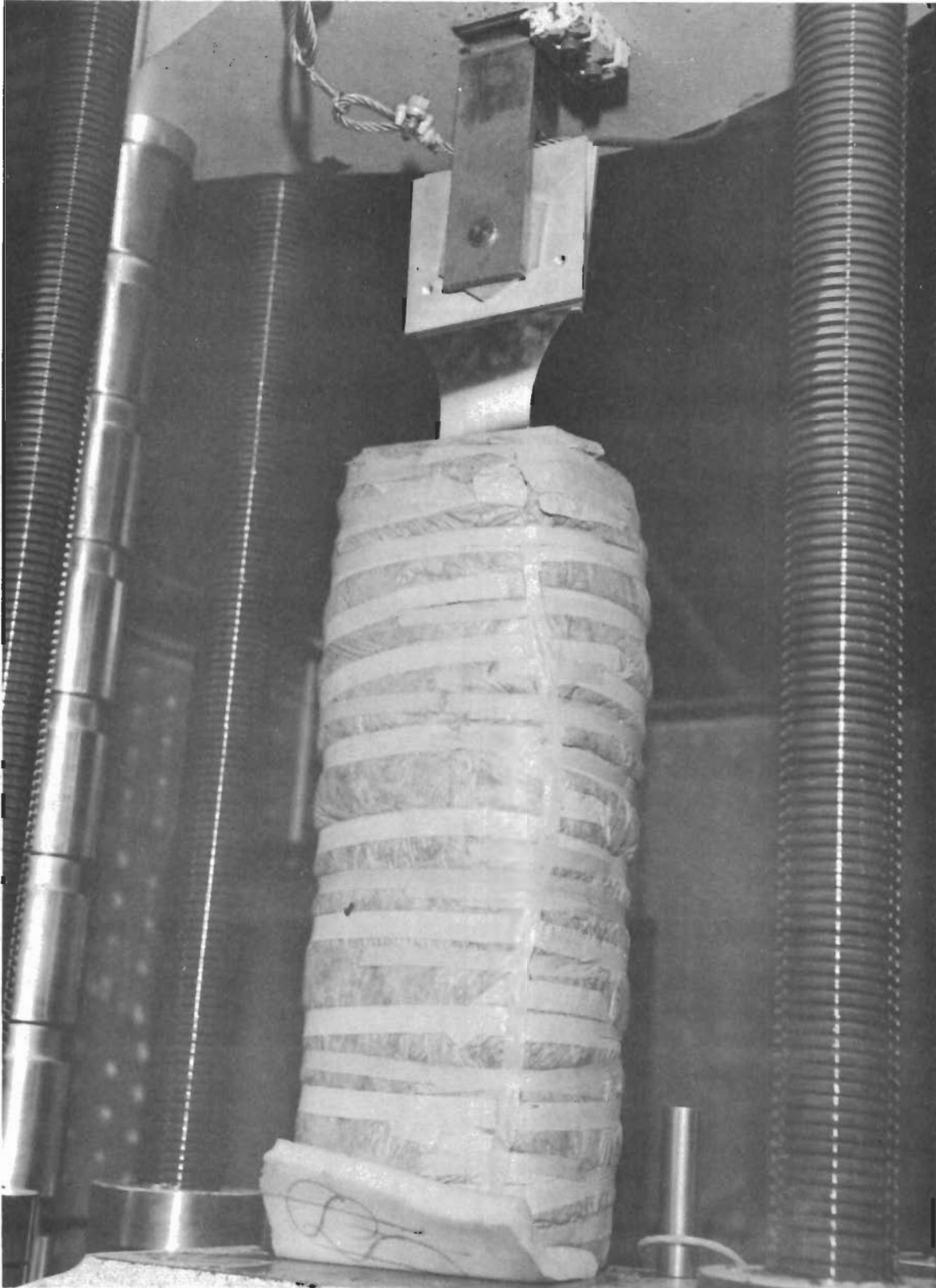

Figure 22. Fatigue Specimen in Liquid-Nitrogen Cryostat



Figure 23. Outdoor Liquid Hydrogen Test Area

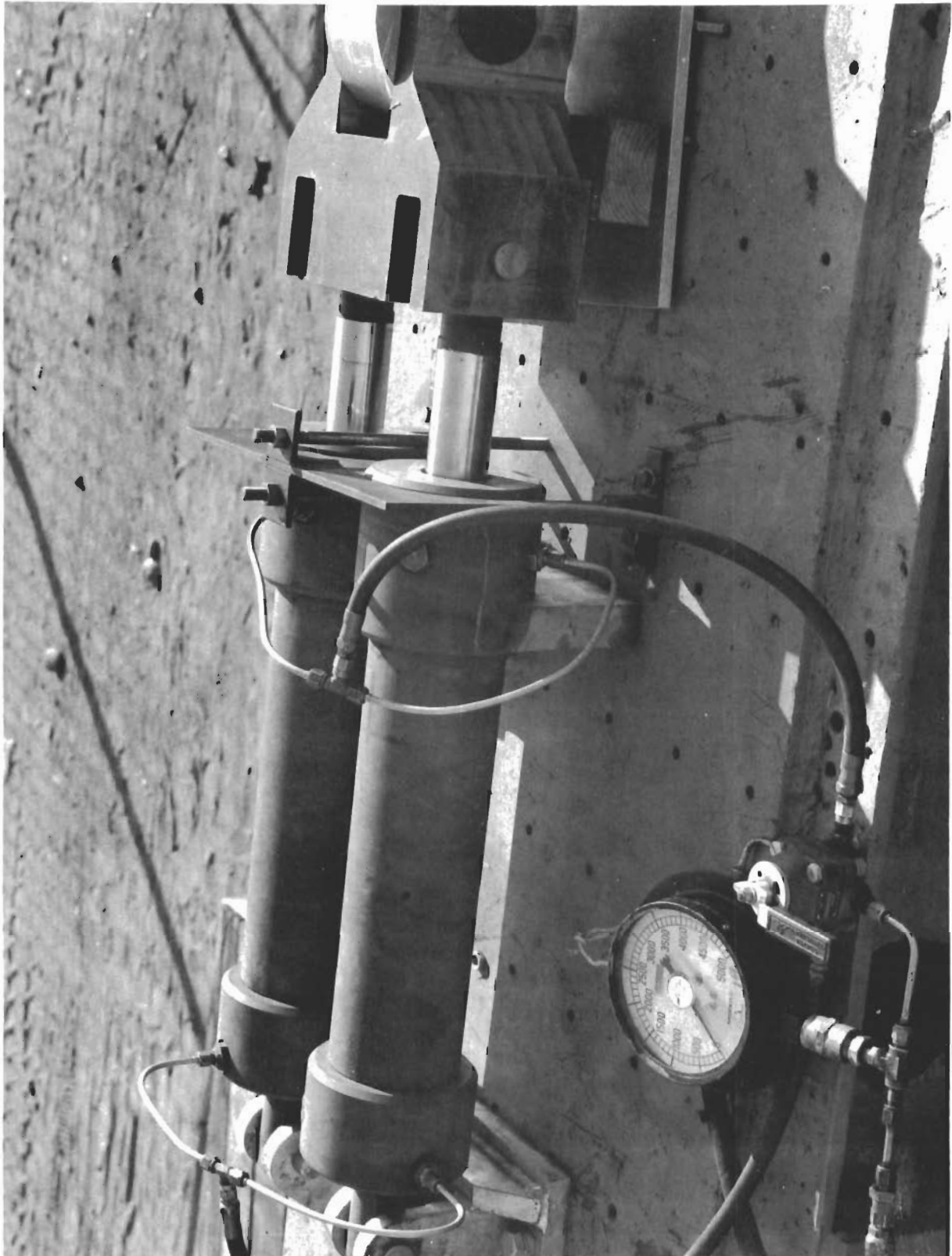

Figure 24. Hydraulic Rams - Fatigue Test Equipment

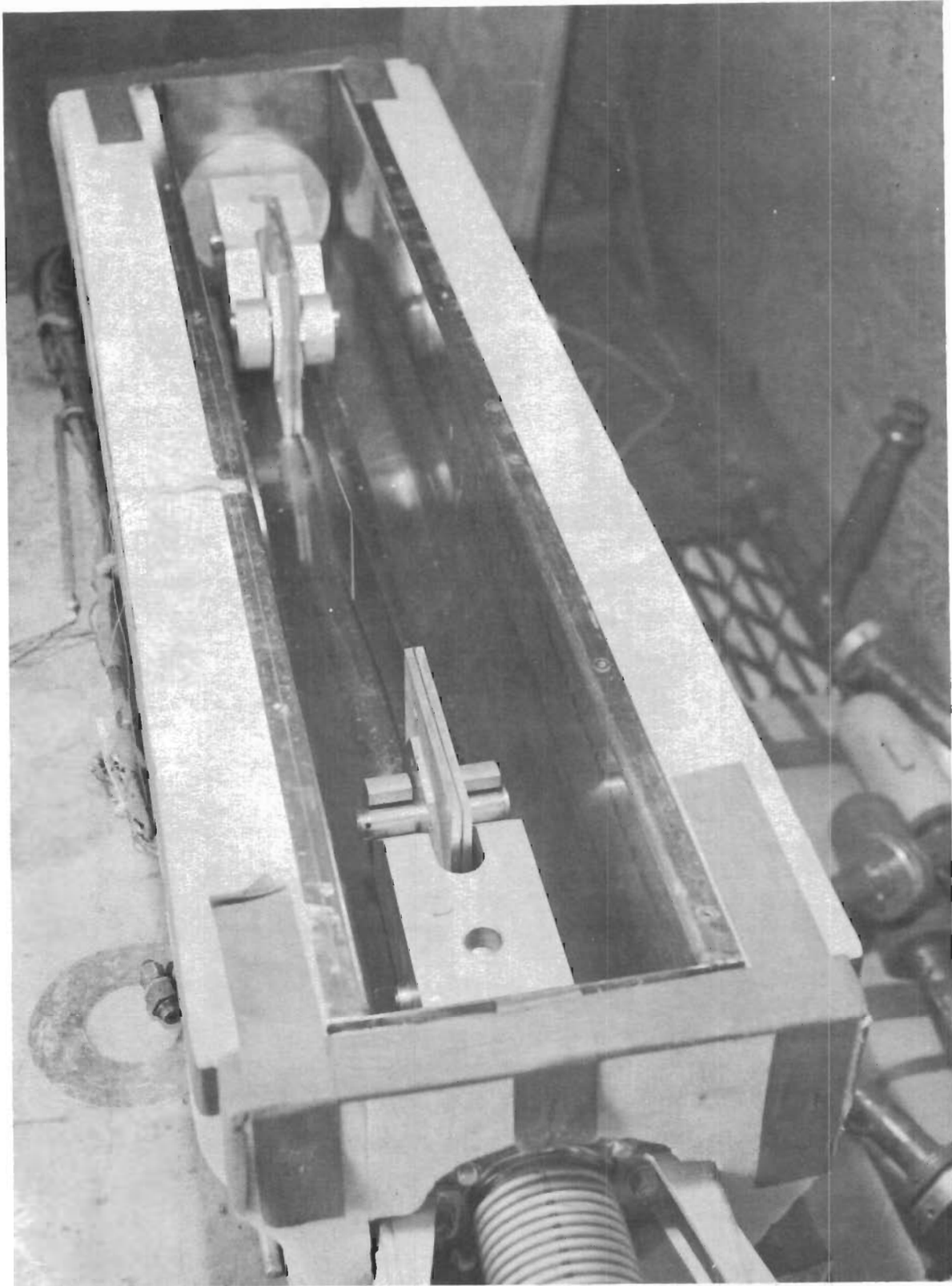

Figure 25. Fatigue Test Chamber (for Room Temperature and Liquid-Nitrogen Testing)

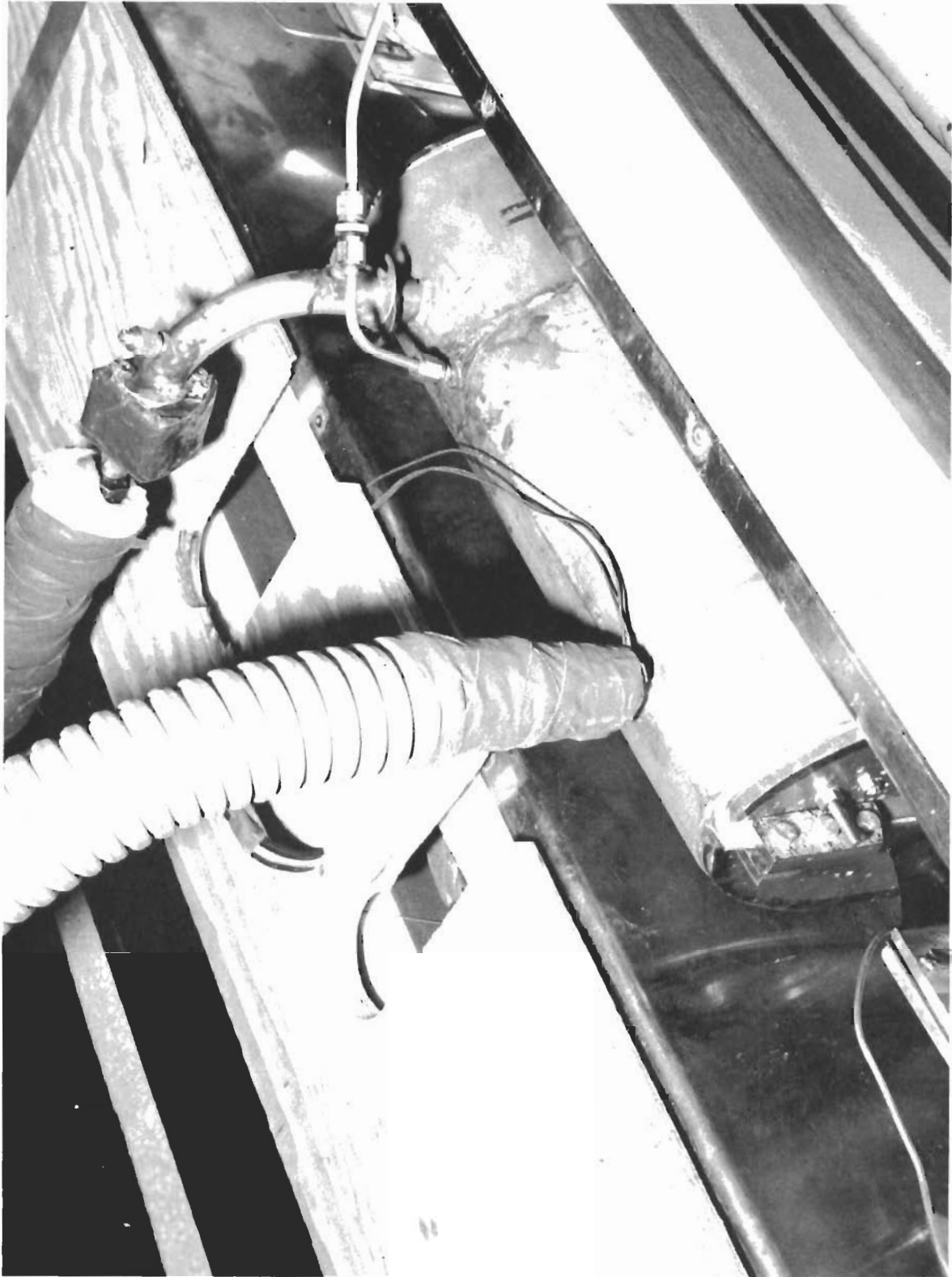

Figure 26. Fatigue Test Bed with Liquid-Hydrogen Test Chamber

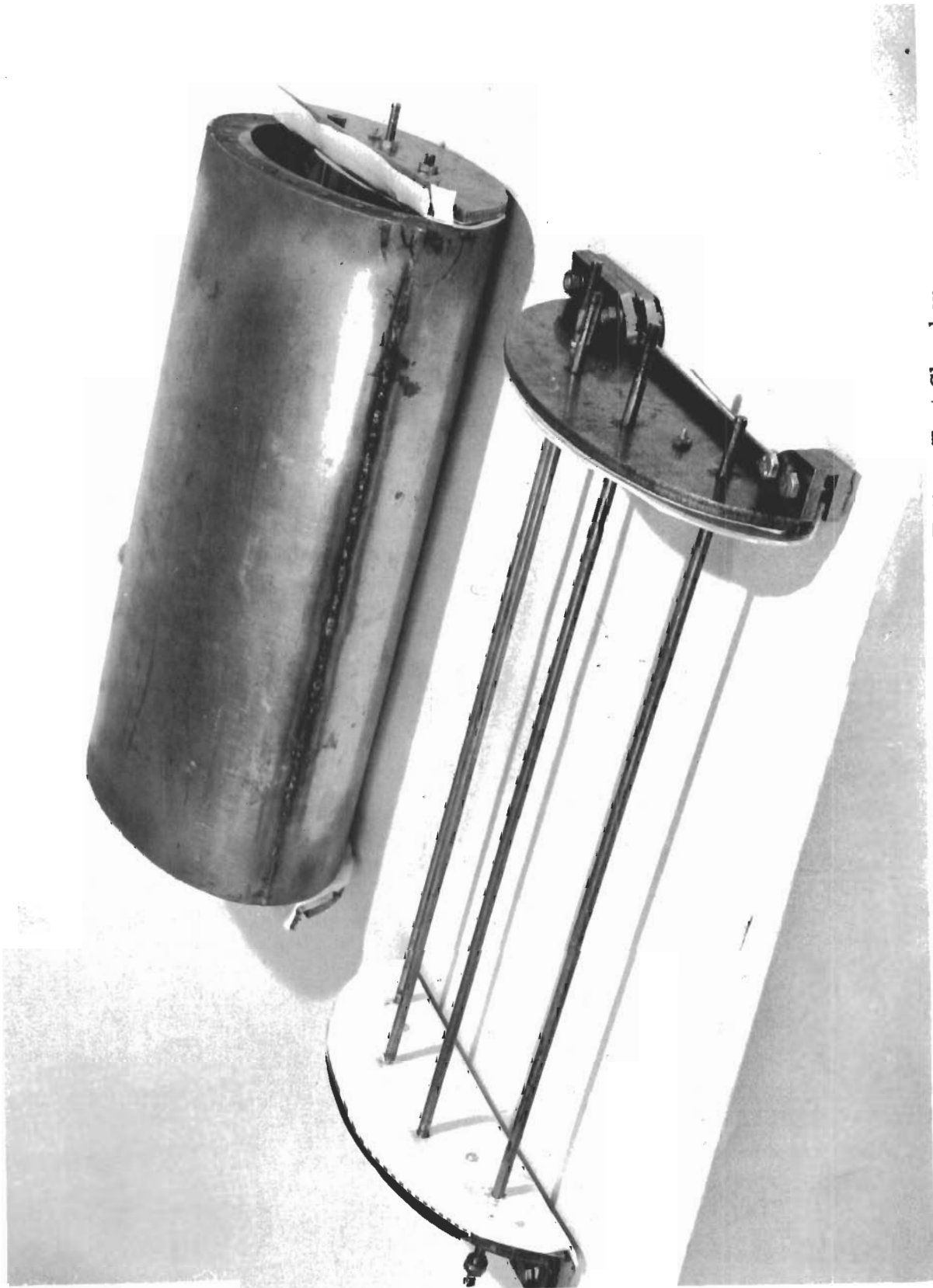

Figure 27. View of Liquid-Hydrogen Fatigue Test Chamber

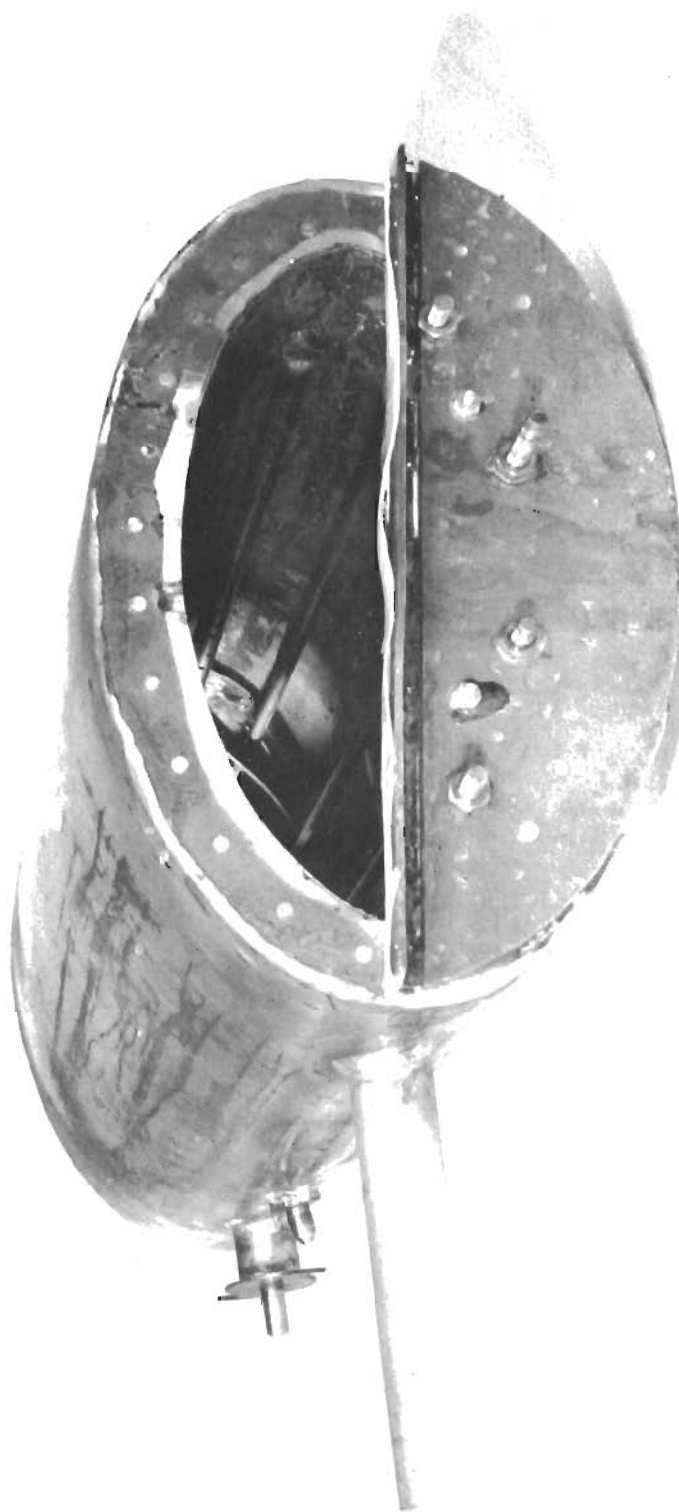

Figure 28. View of Liquid-Hydrogen Fatigue Test Chamber (Assembled)

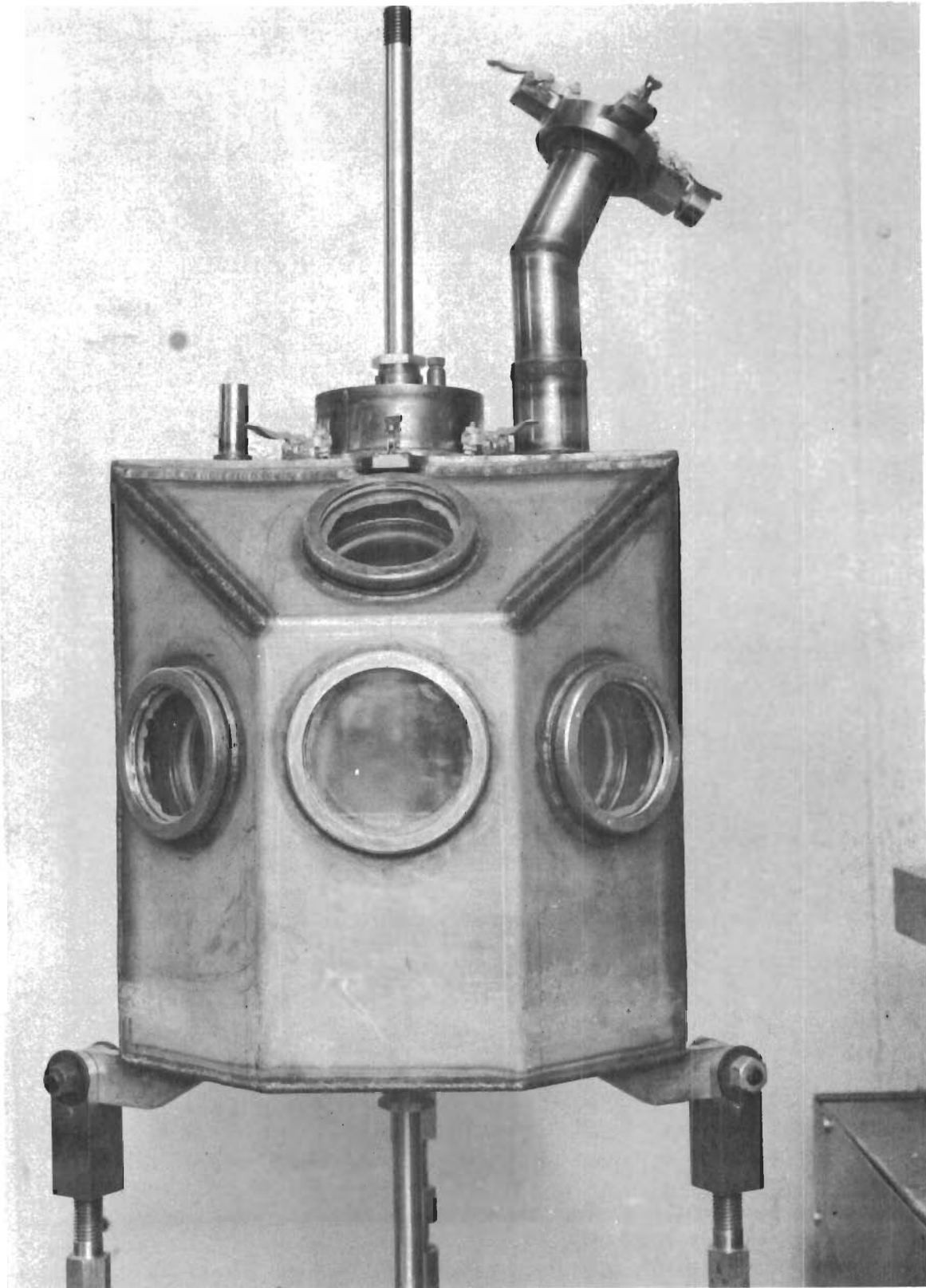

Figure 29. Liquid-Hydrogen Cryostat for Crack Propagation Testing

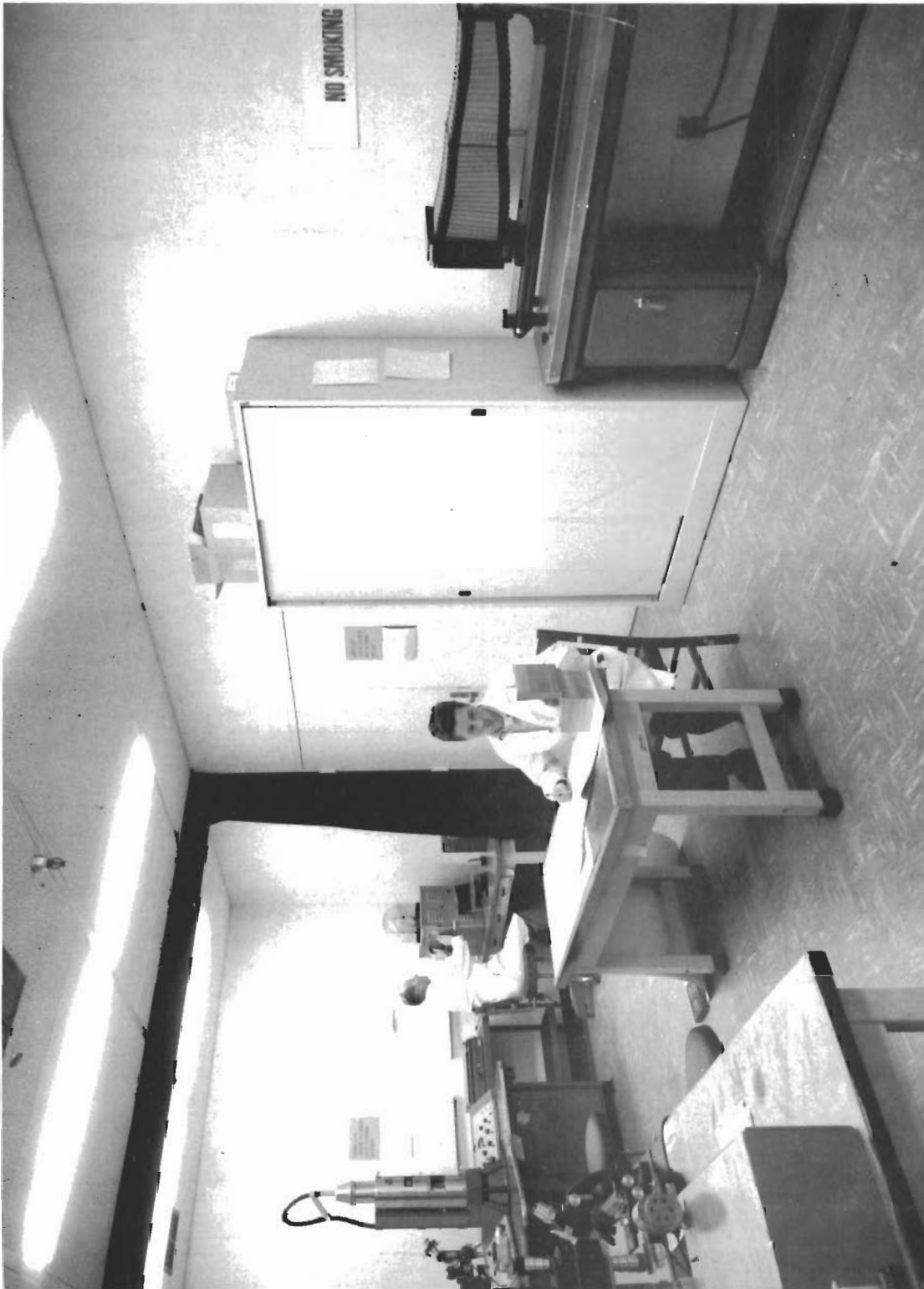

Figure 30. Metallographic Laboratory

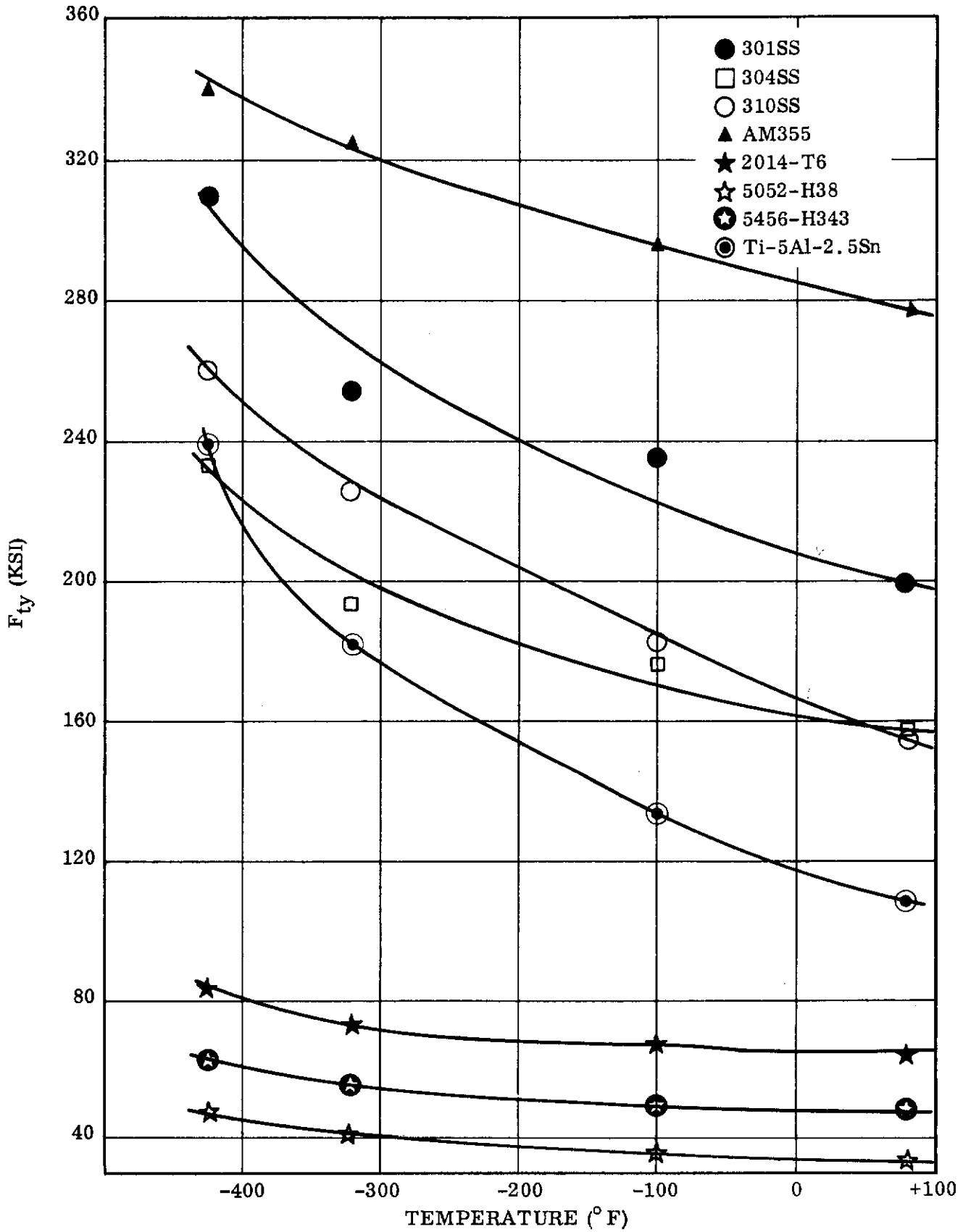

Figure 31. F_{ty} Versus Temperature (Longitudinal)

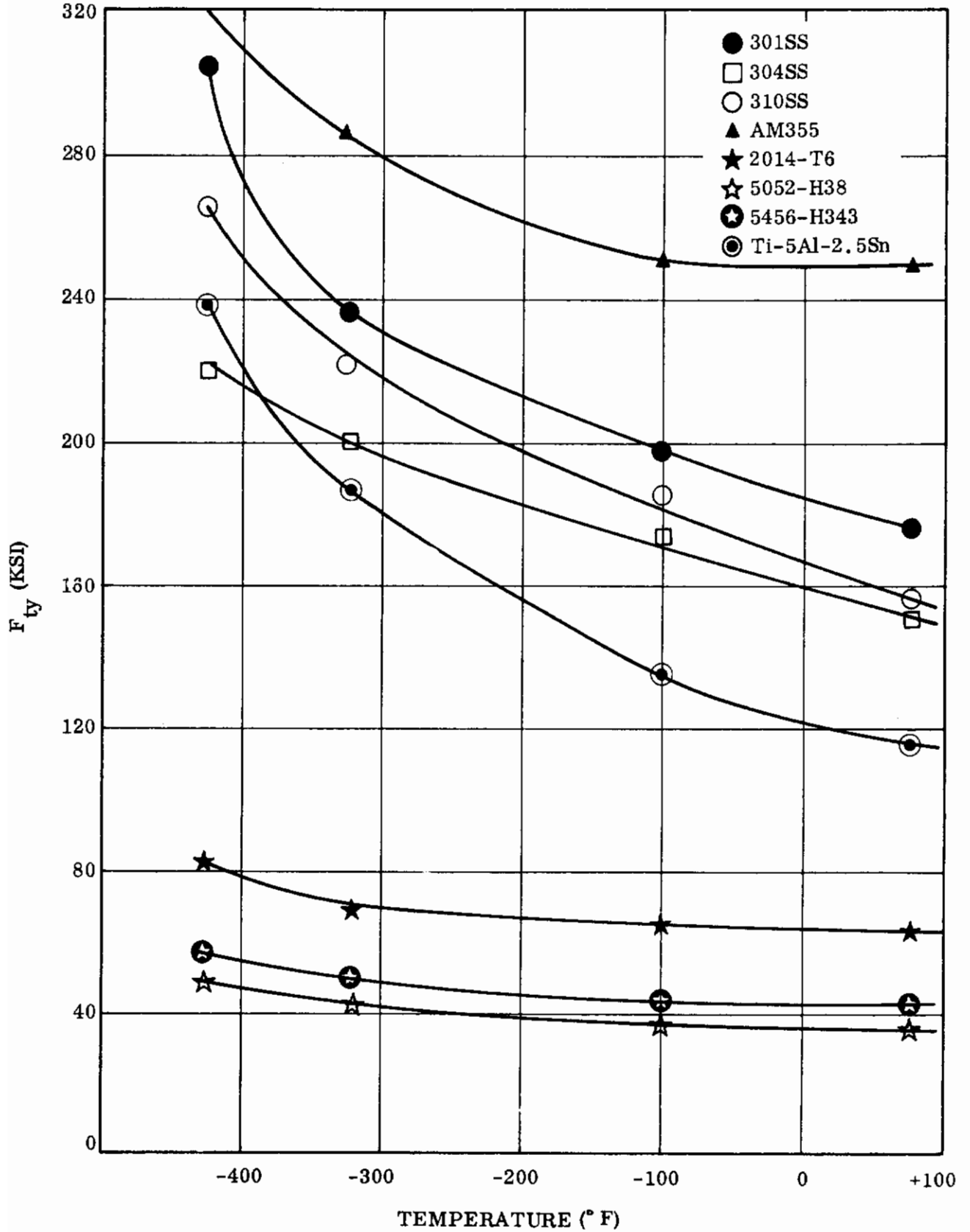

Figure 32. F_{ty} Versus Temperature (Transverse)

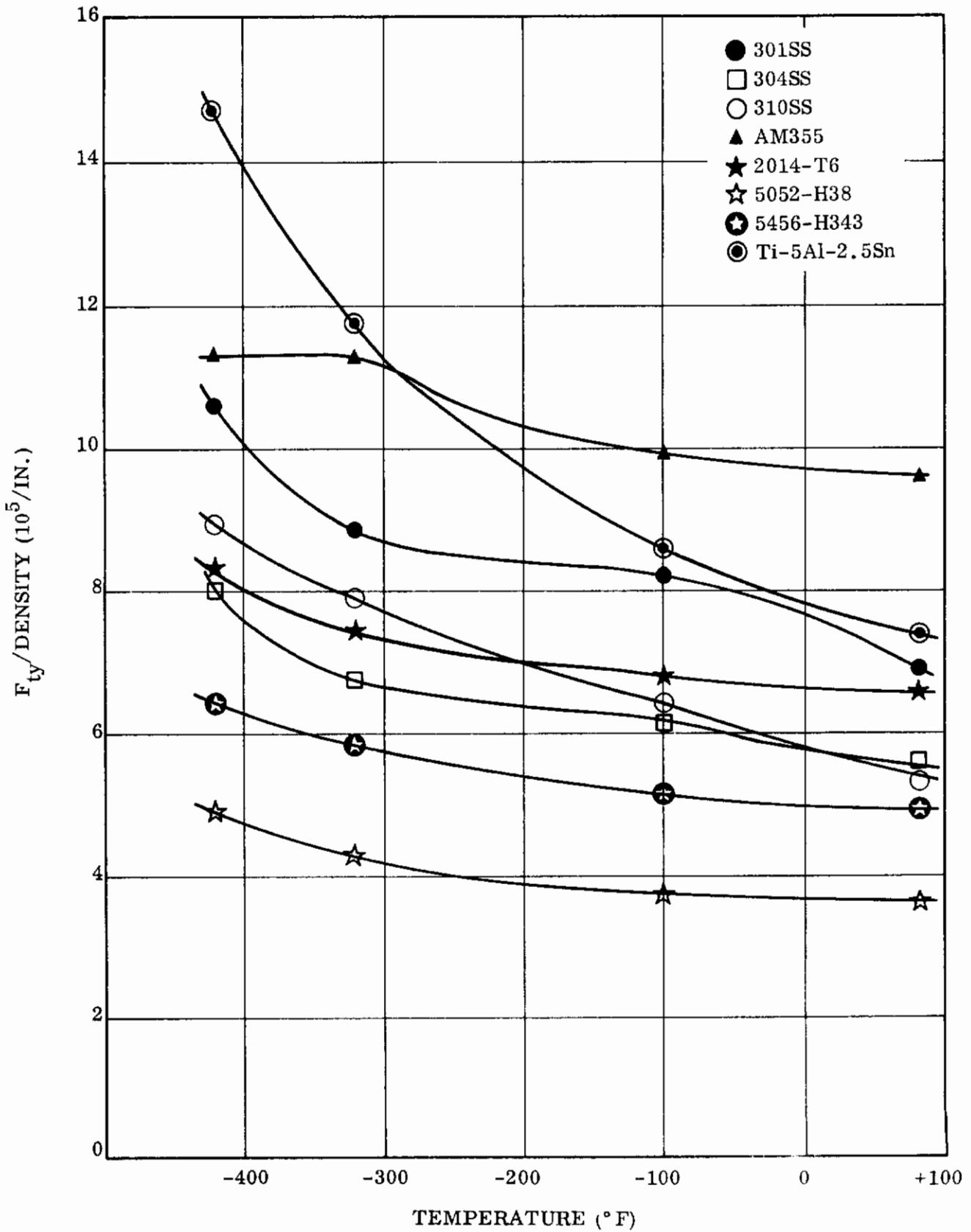

Figure 33. $F_{ty}/\text{Density}$ Versus Temperature (Longitudinal)

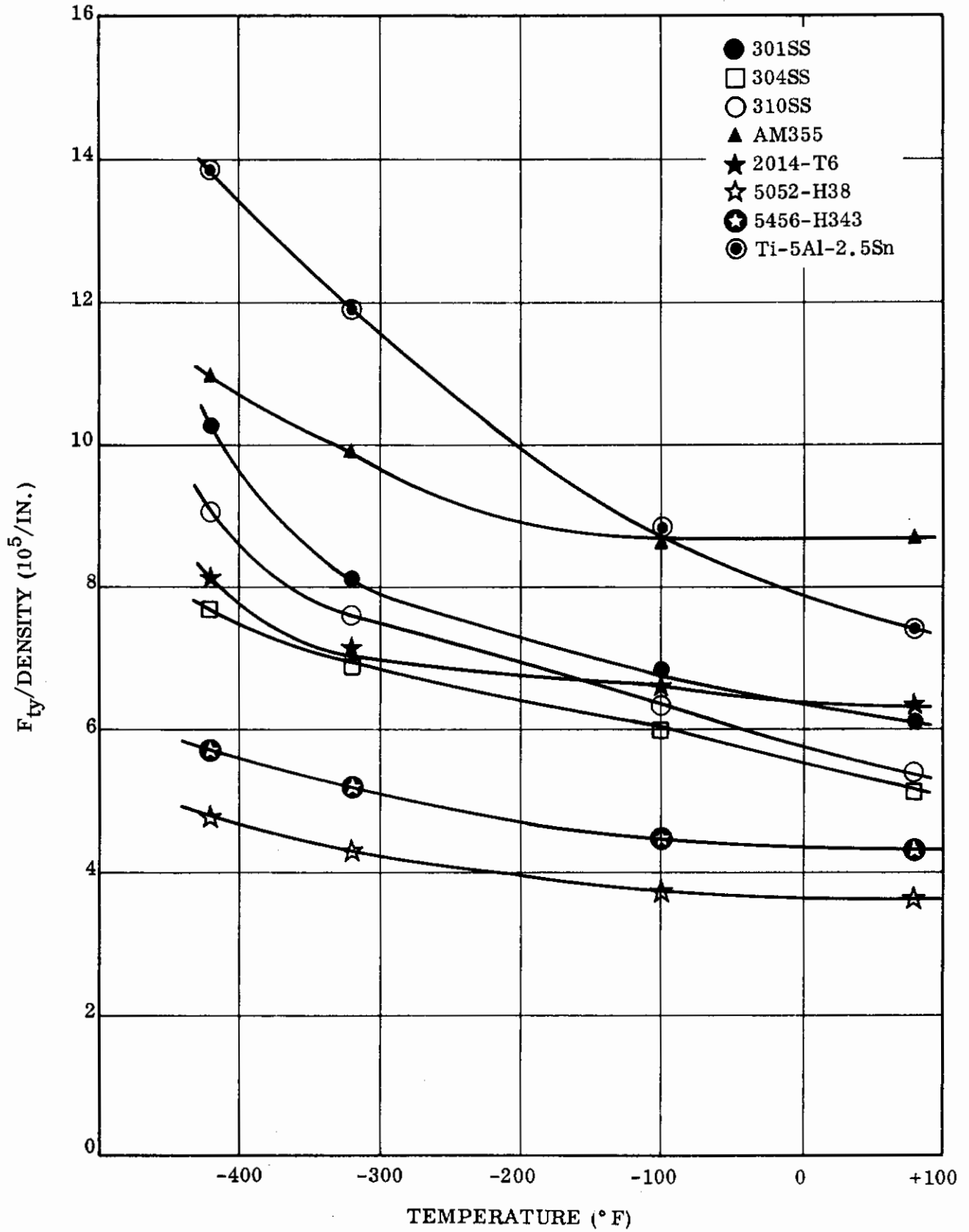

Figure 34. $F_{ty}/Density$ Versus Temperature (Transverse)

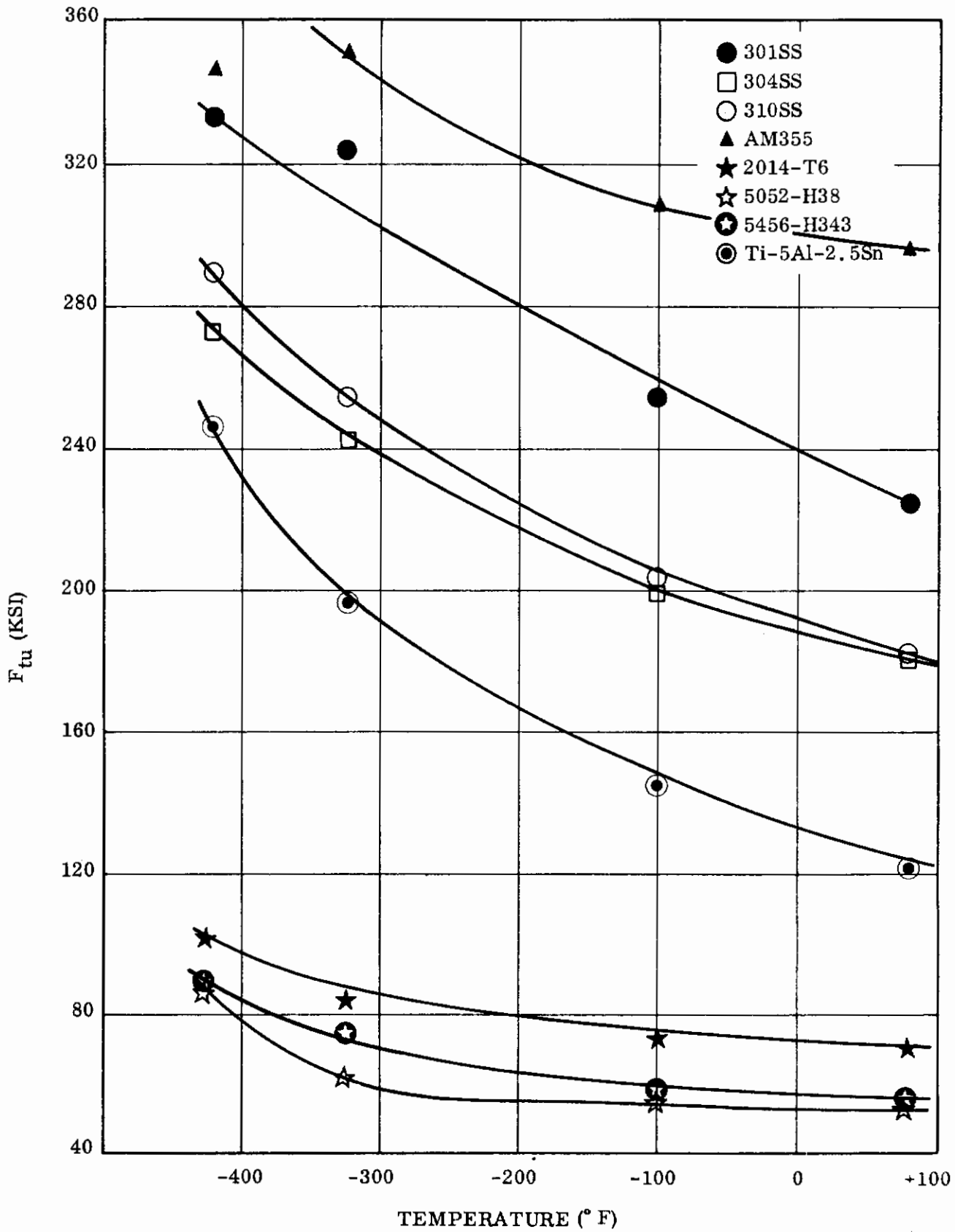

Figure 35. F_{tu} Versus Temperature (Longitudinal)

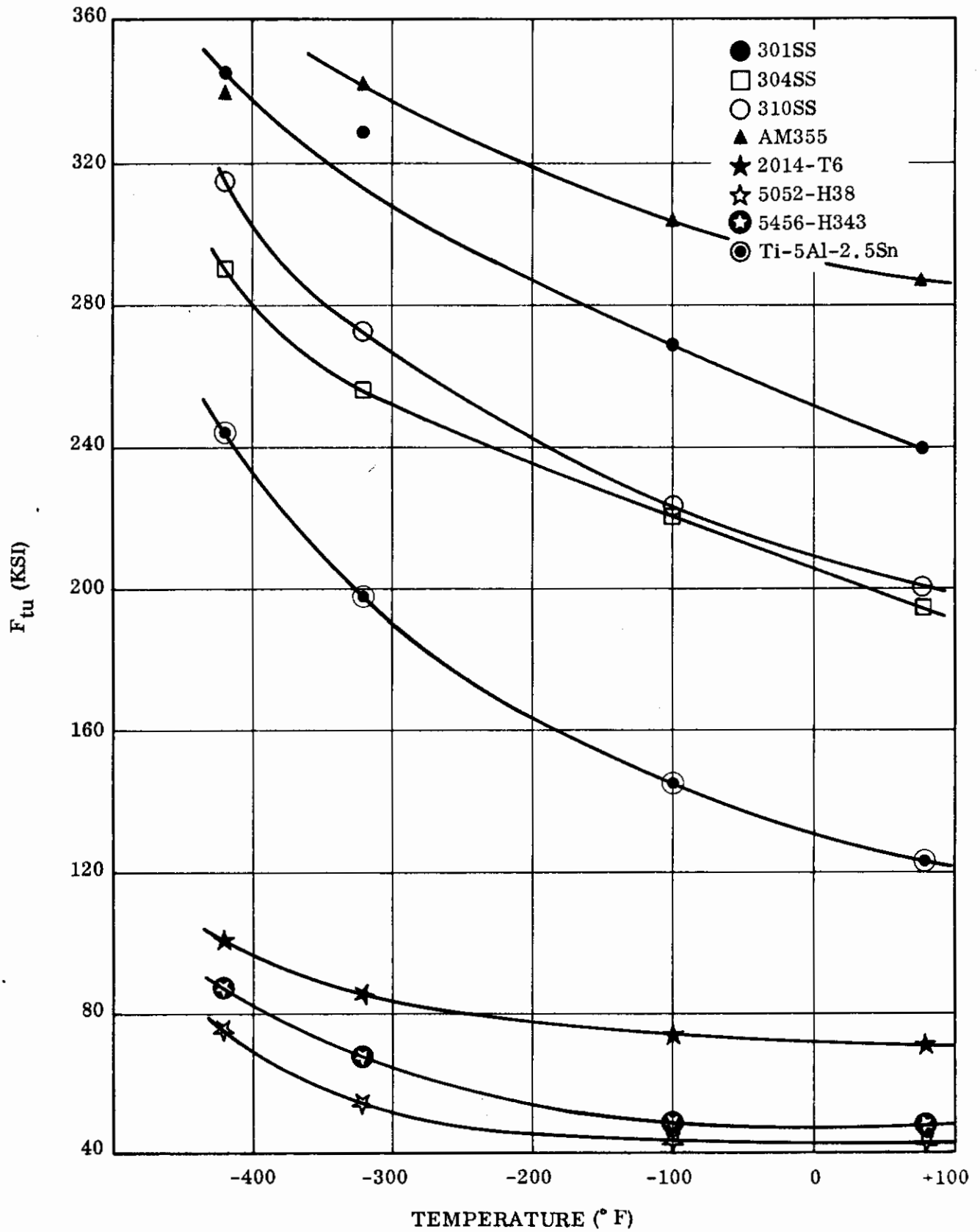

Figure 36. F_{tu} Versus Temperature (Transverse)

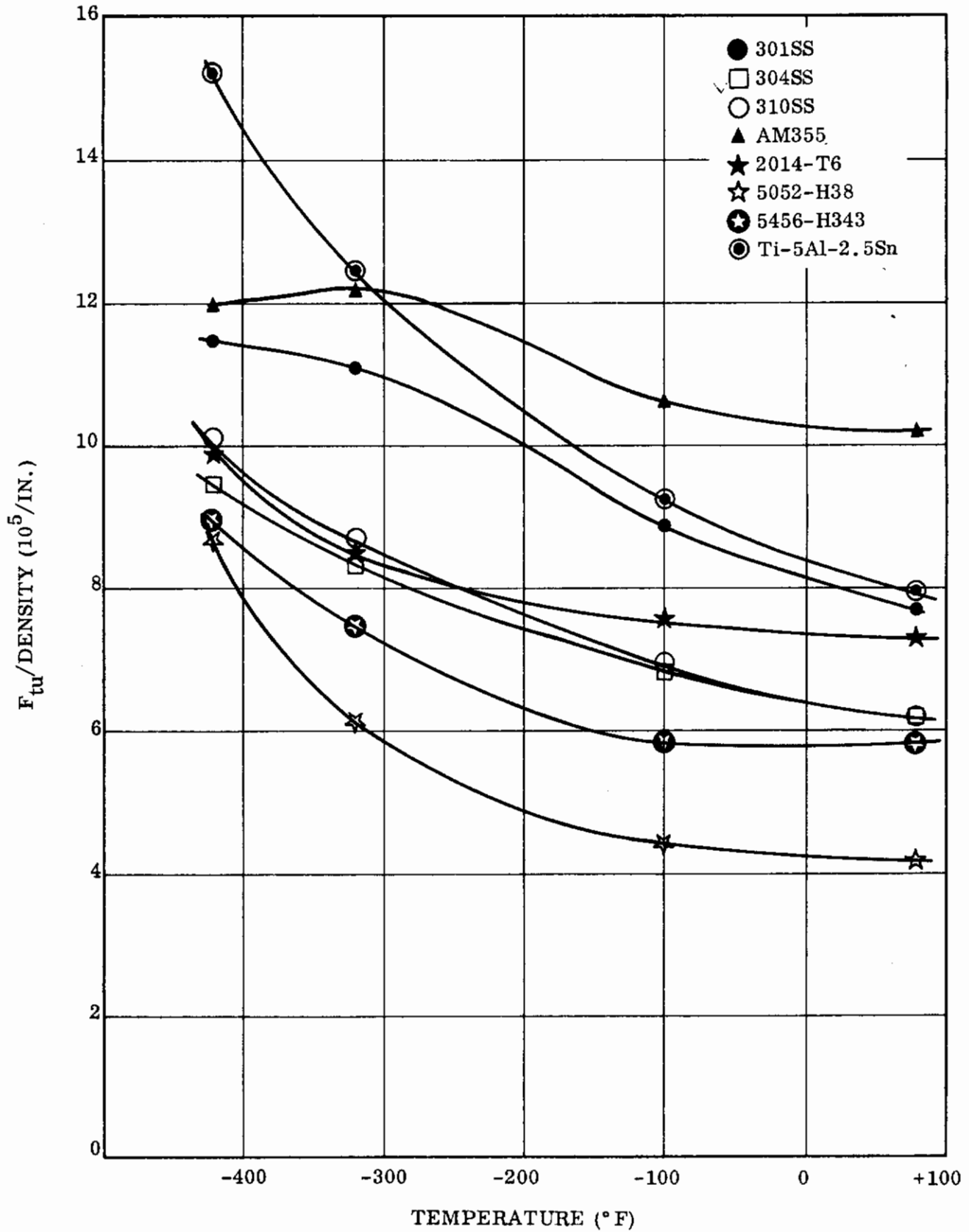

Figure 37. $F_{tu}/\text{Density}$ Versus Temperature (Longitudinal)

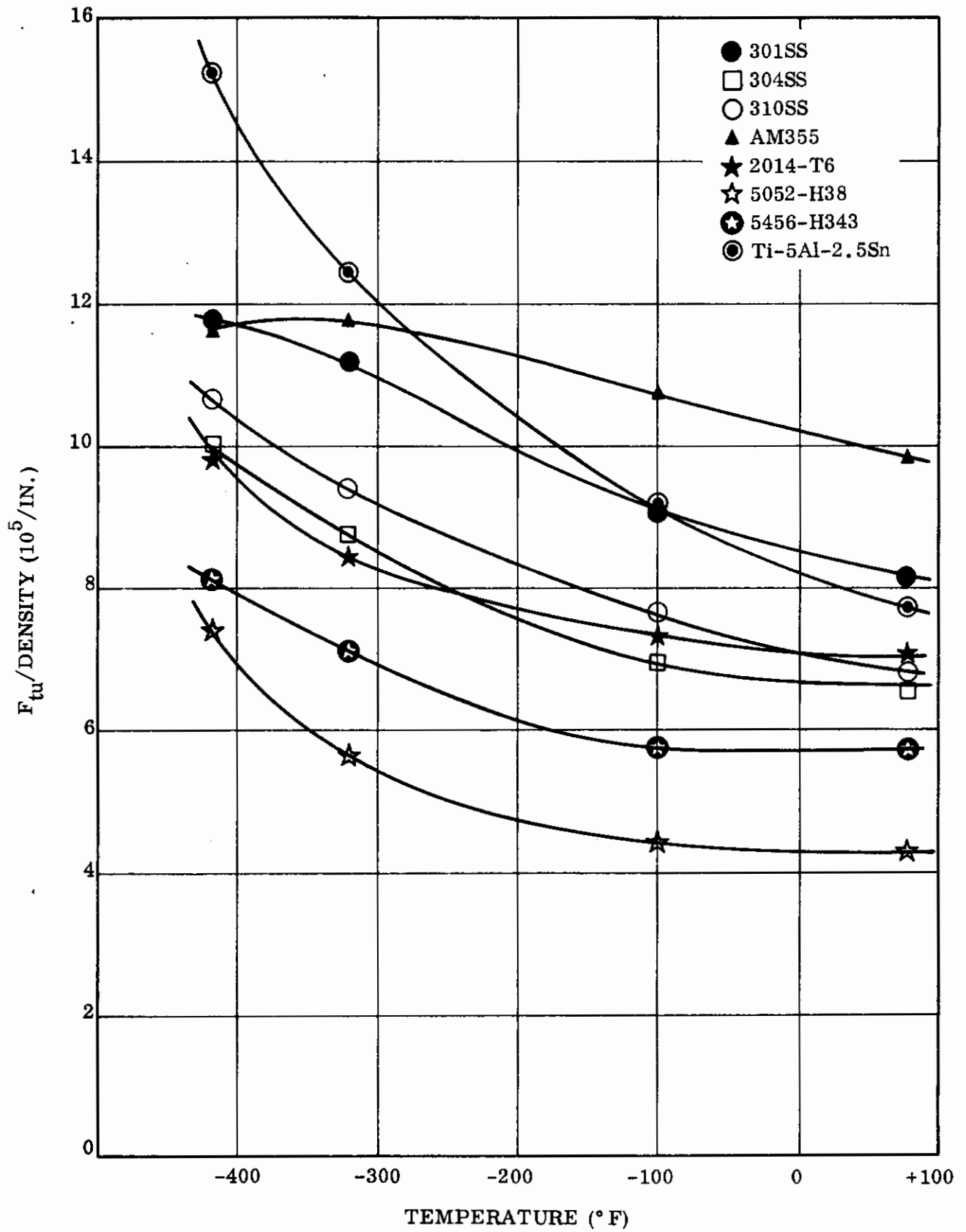

Figure 38. $F_{tu}/\text{Density}$ Versus Temperature (Transverse)

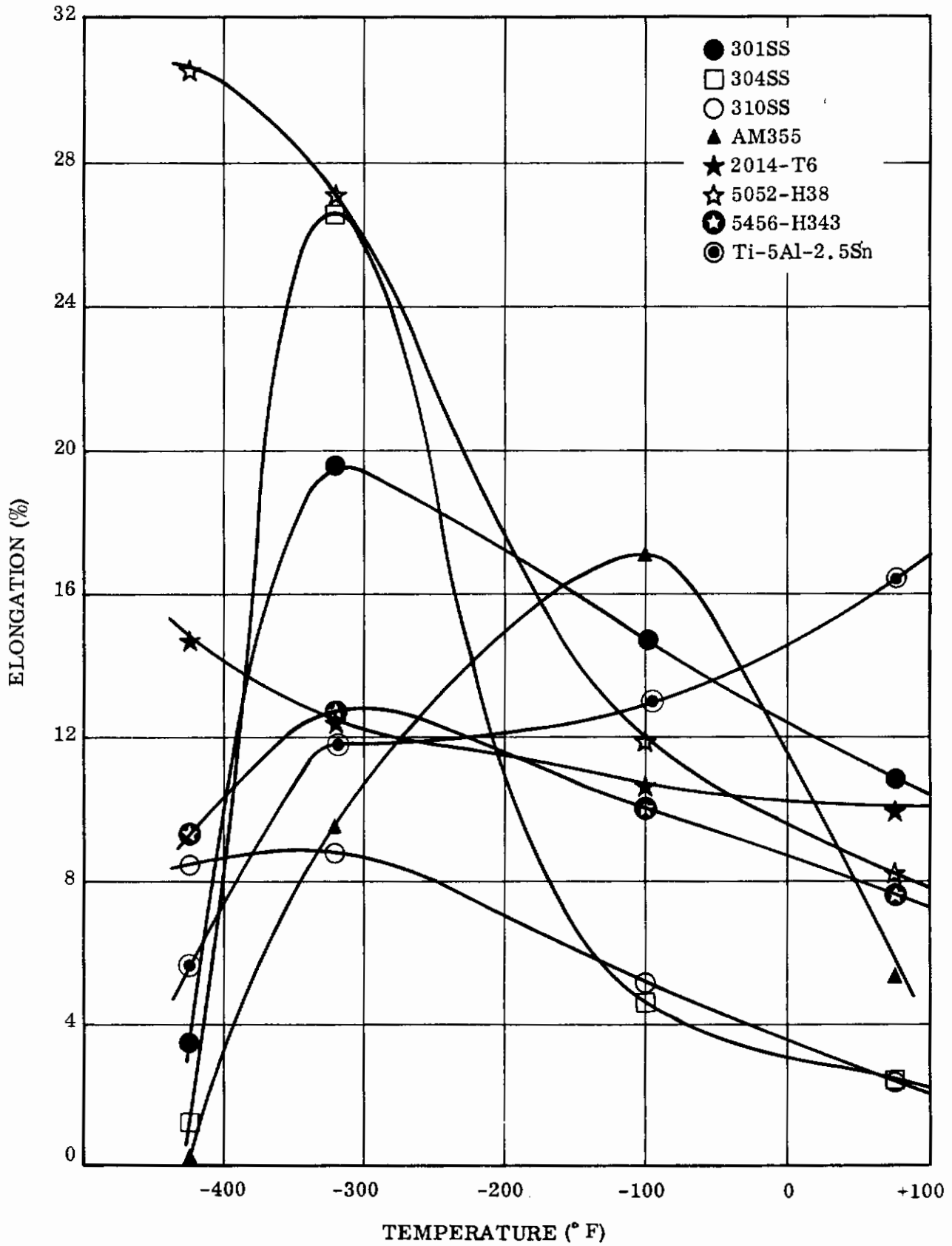

Figure 39. Elongation Versus Temperature (Longitudinal)

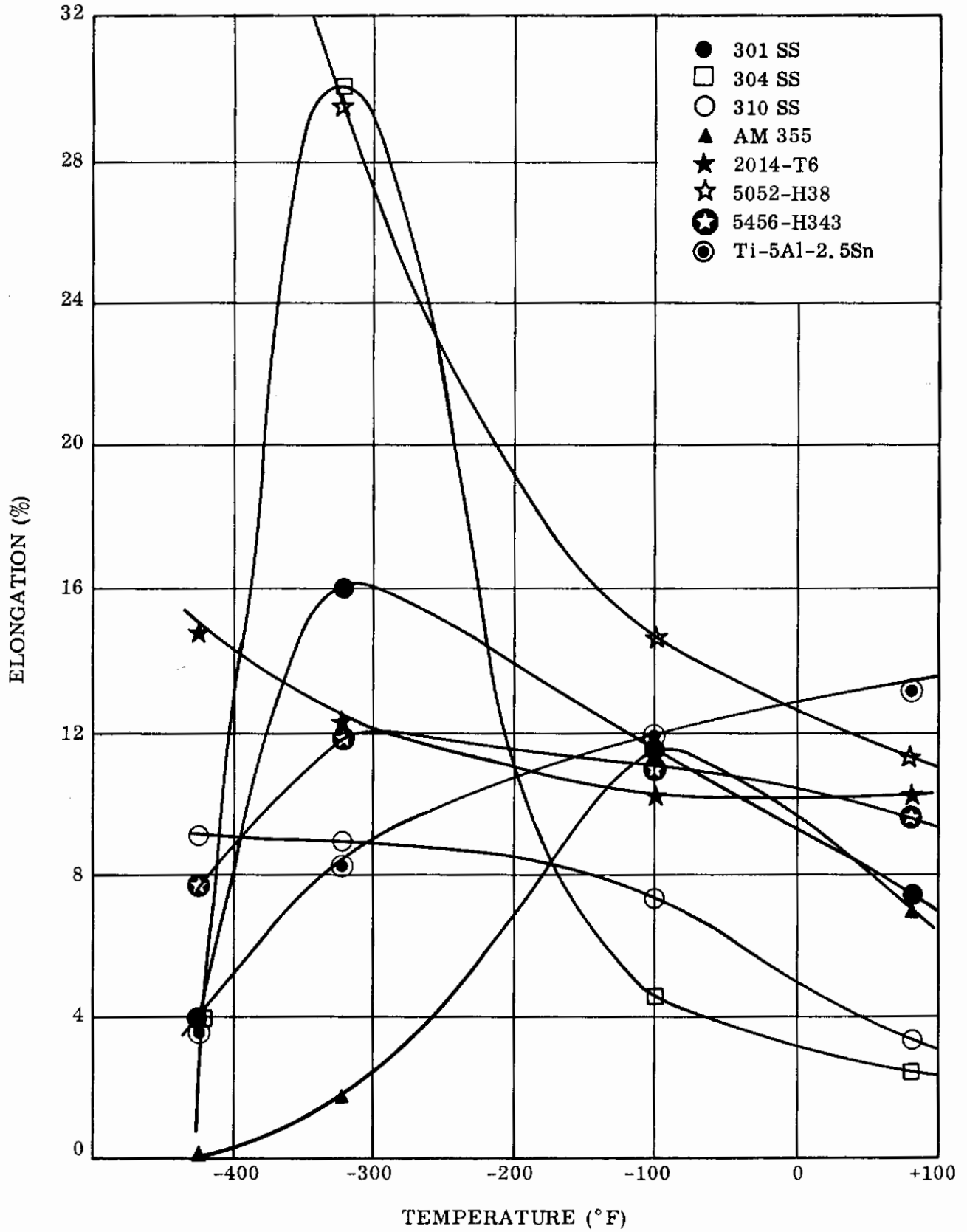

Figure 40. Elongation Versus Temperature (Transverse)

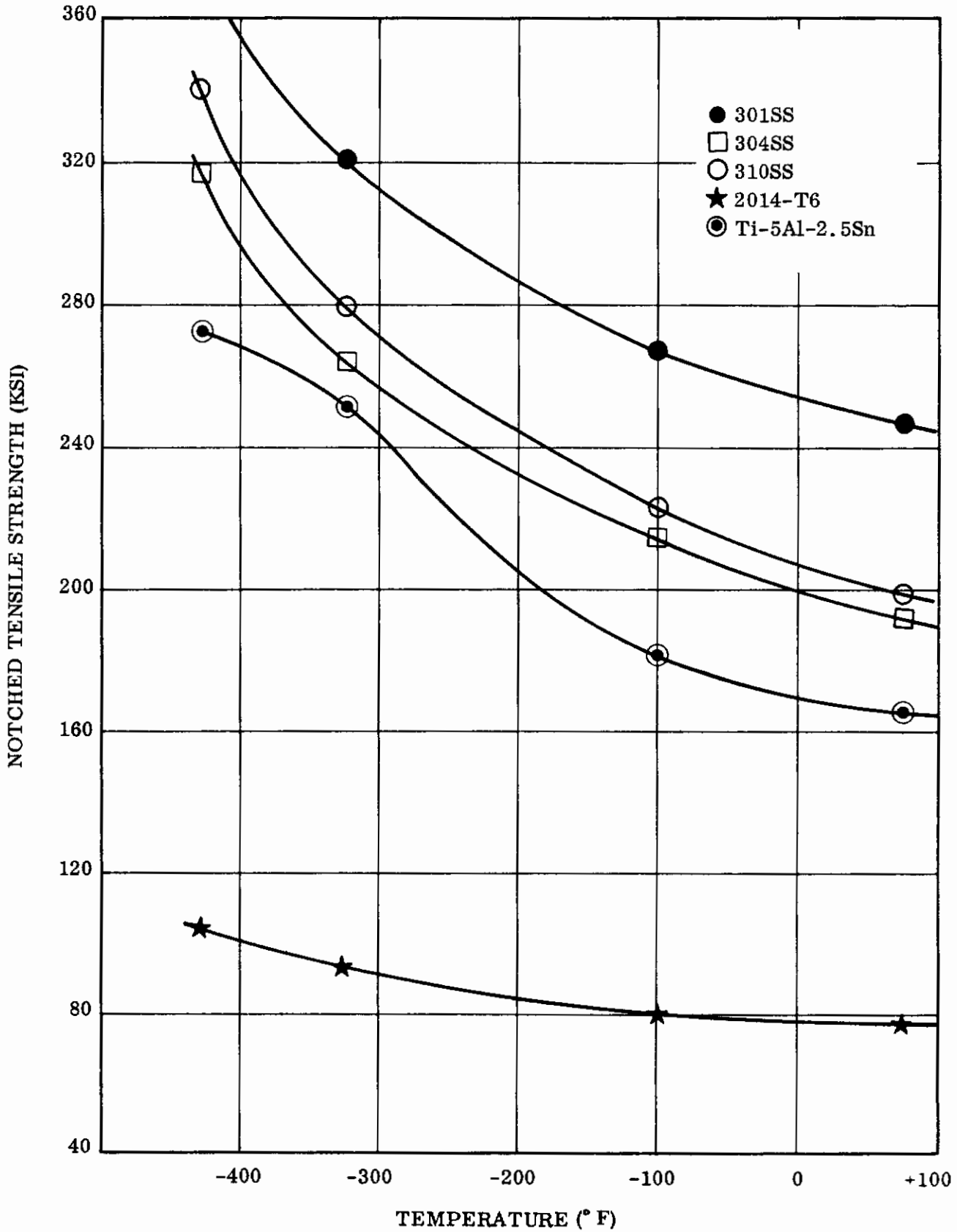

Figure 41. Notched Tensile Strength ($K_t = 3.2$) Versus Temperature (Longitudinal)

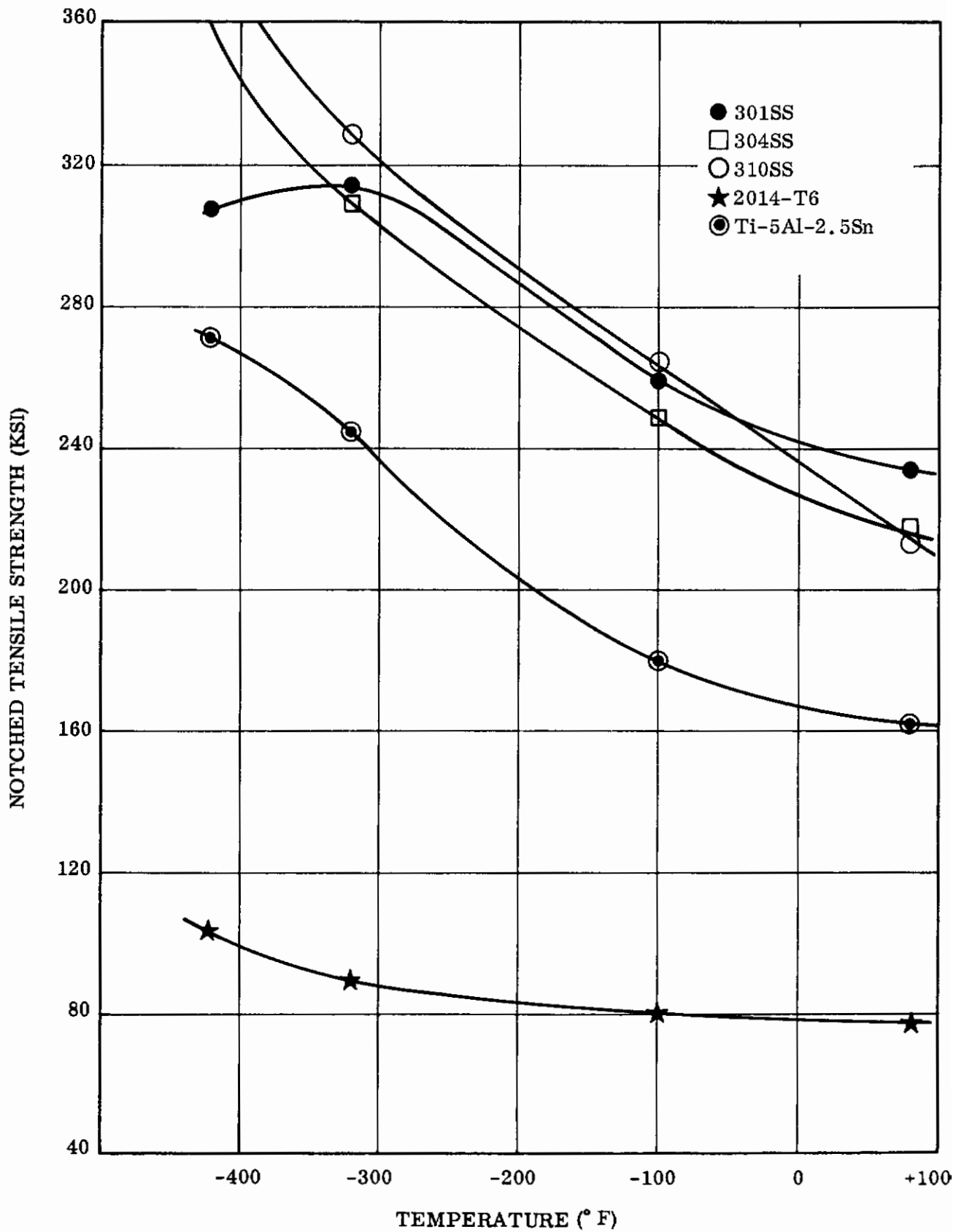

Figure 42. Notched Tensile Strength ($K_t = 3.2$) Versus Temperature (Transverse)

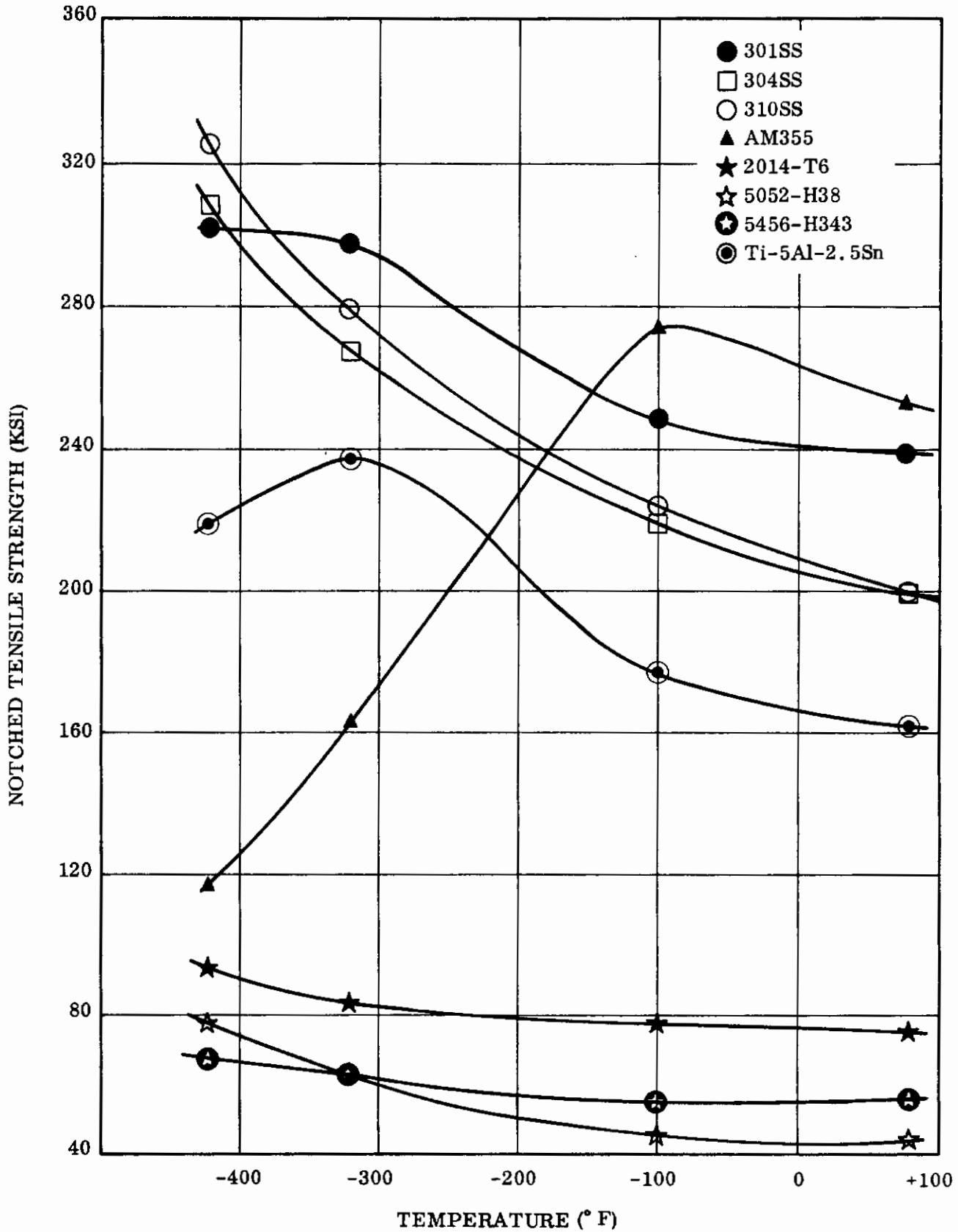

Figure 43. Notched Tensile Strength ($K_t = 6.3$) Versus Temperature (Longitudinal)

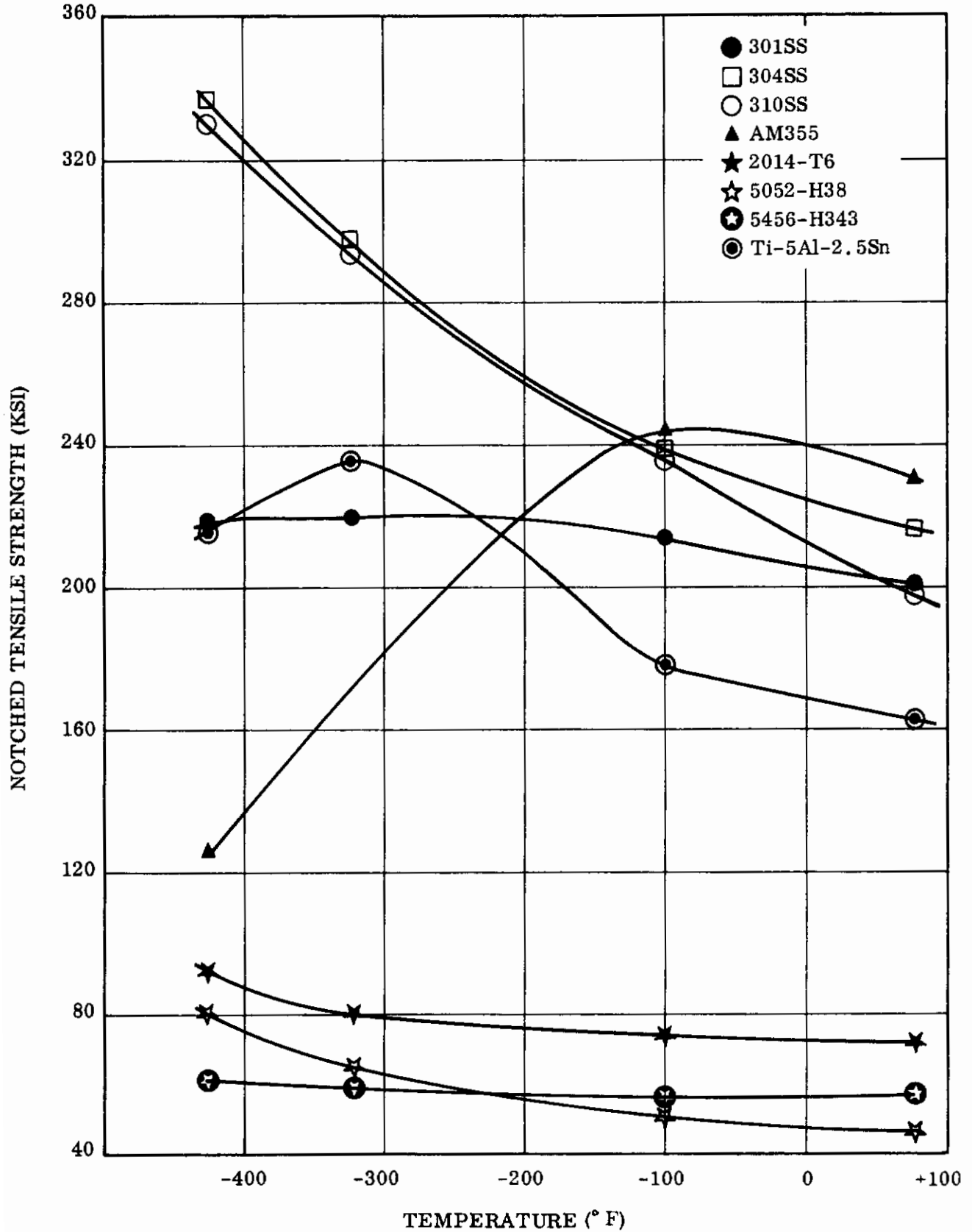

Figure 44. Notched Tensile Strength ($K_t = 6.3$) Versus Temperature (Transverse)

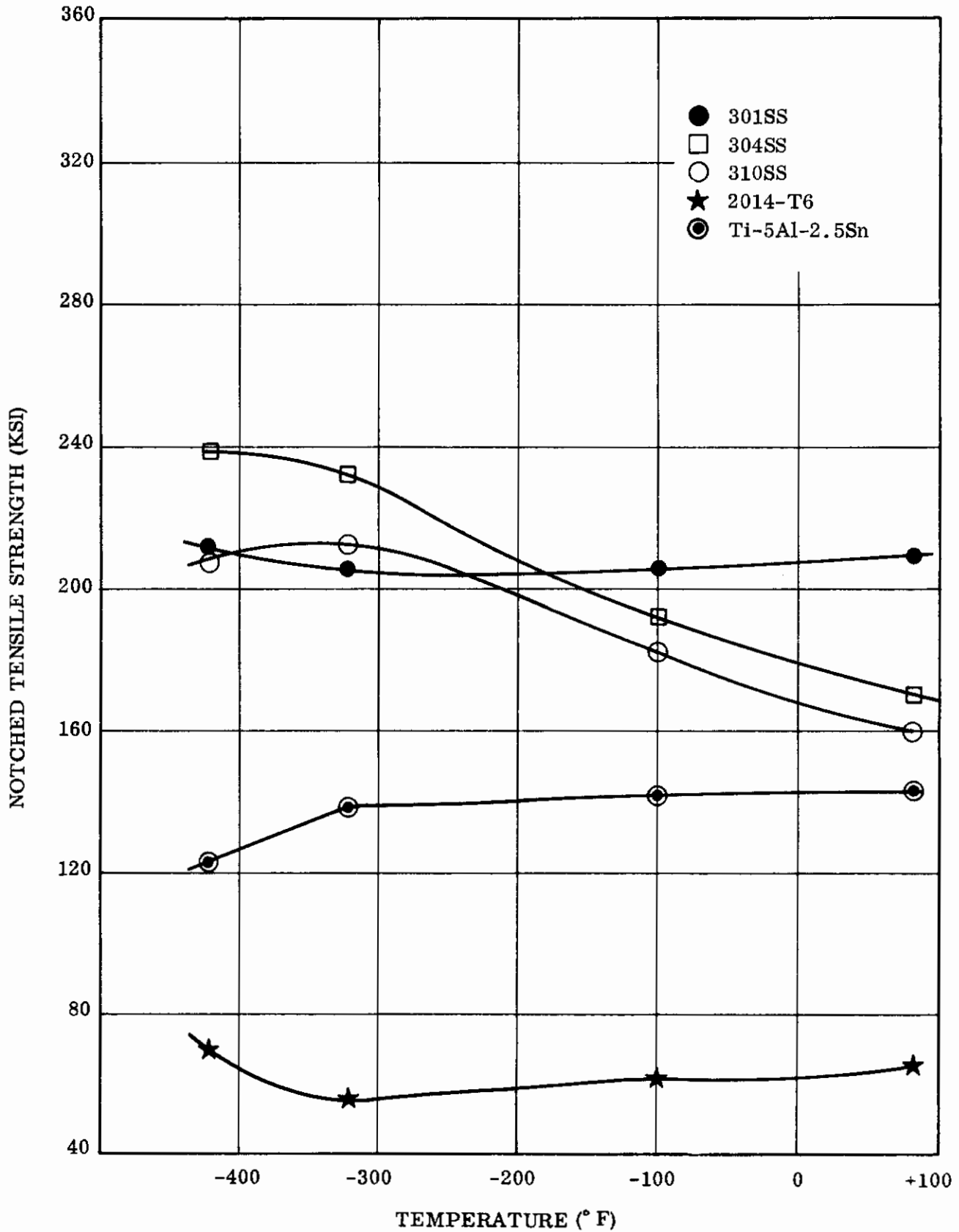

Figure 45. Notched Tensile Strength ($K_t = 19$) Versus Temperature (Longitudinal)

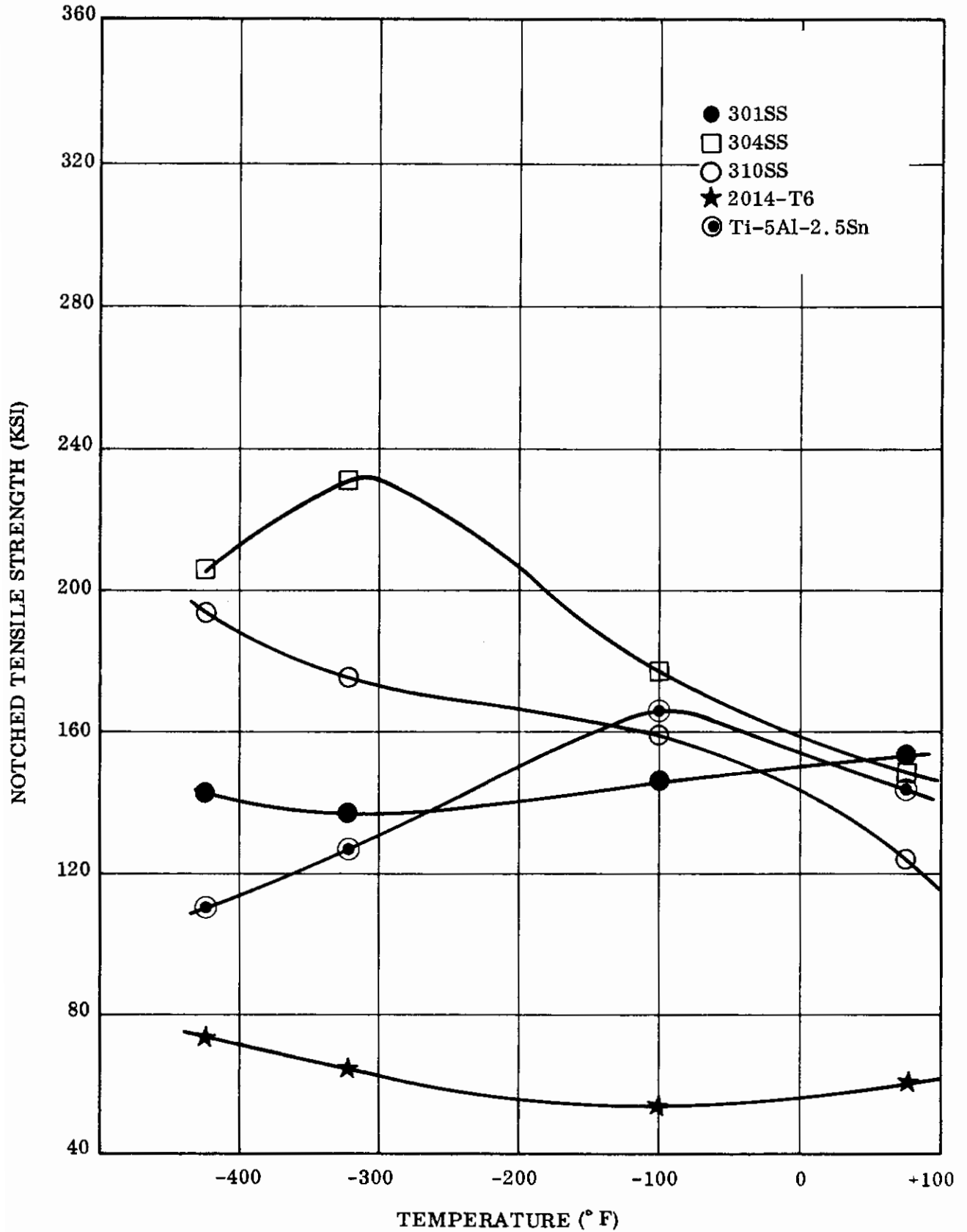

Figure 46. Notched Tensile Strength ($K_t = 19$) Versus Temperature (Transverse)

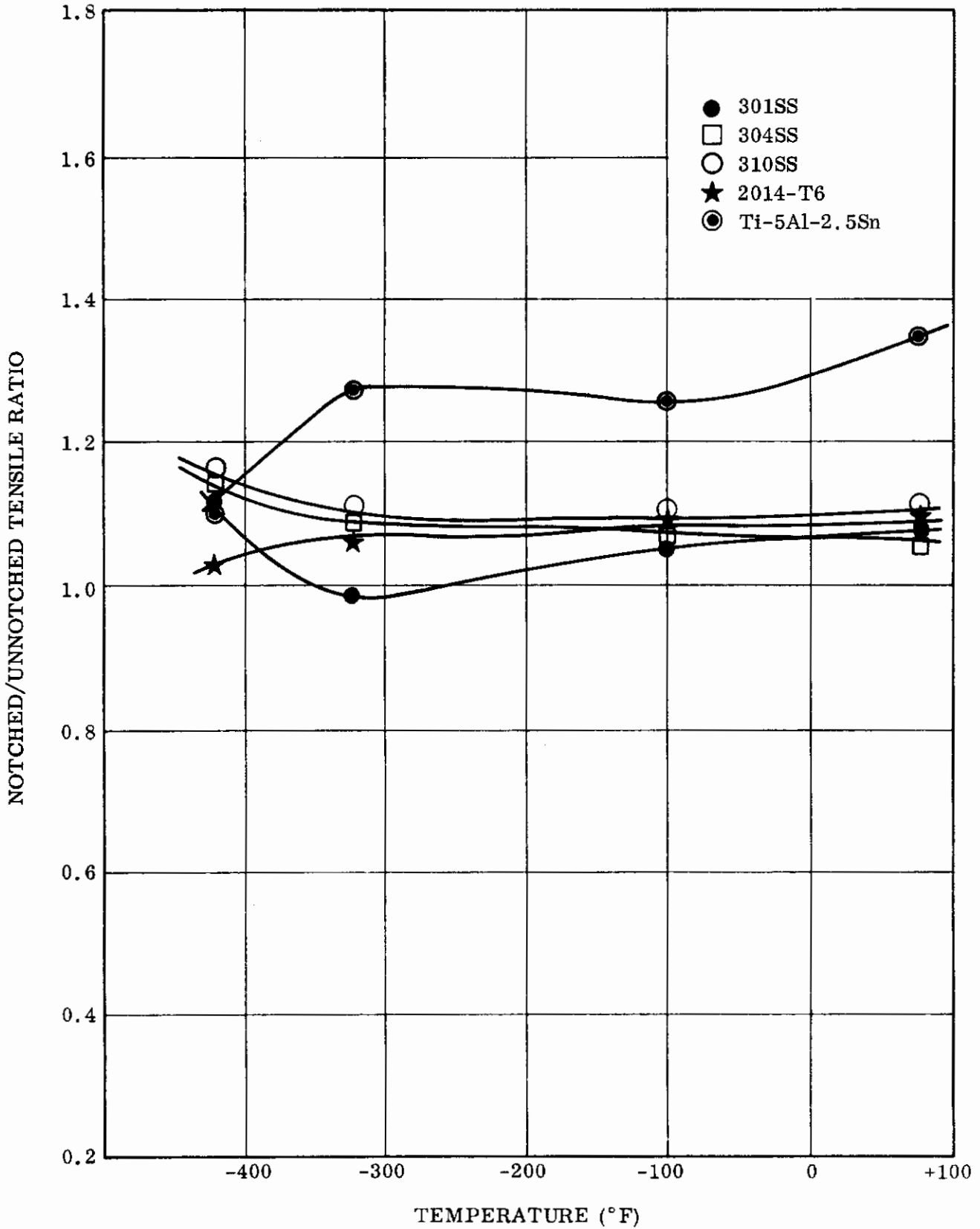

Figure 47. Notched ($K_t = 3.2$)/Unnotched Tensile Ratio Versus Temperature (Longitudinal)

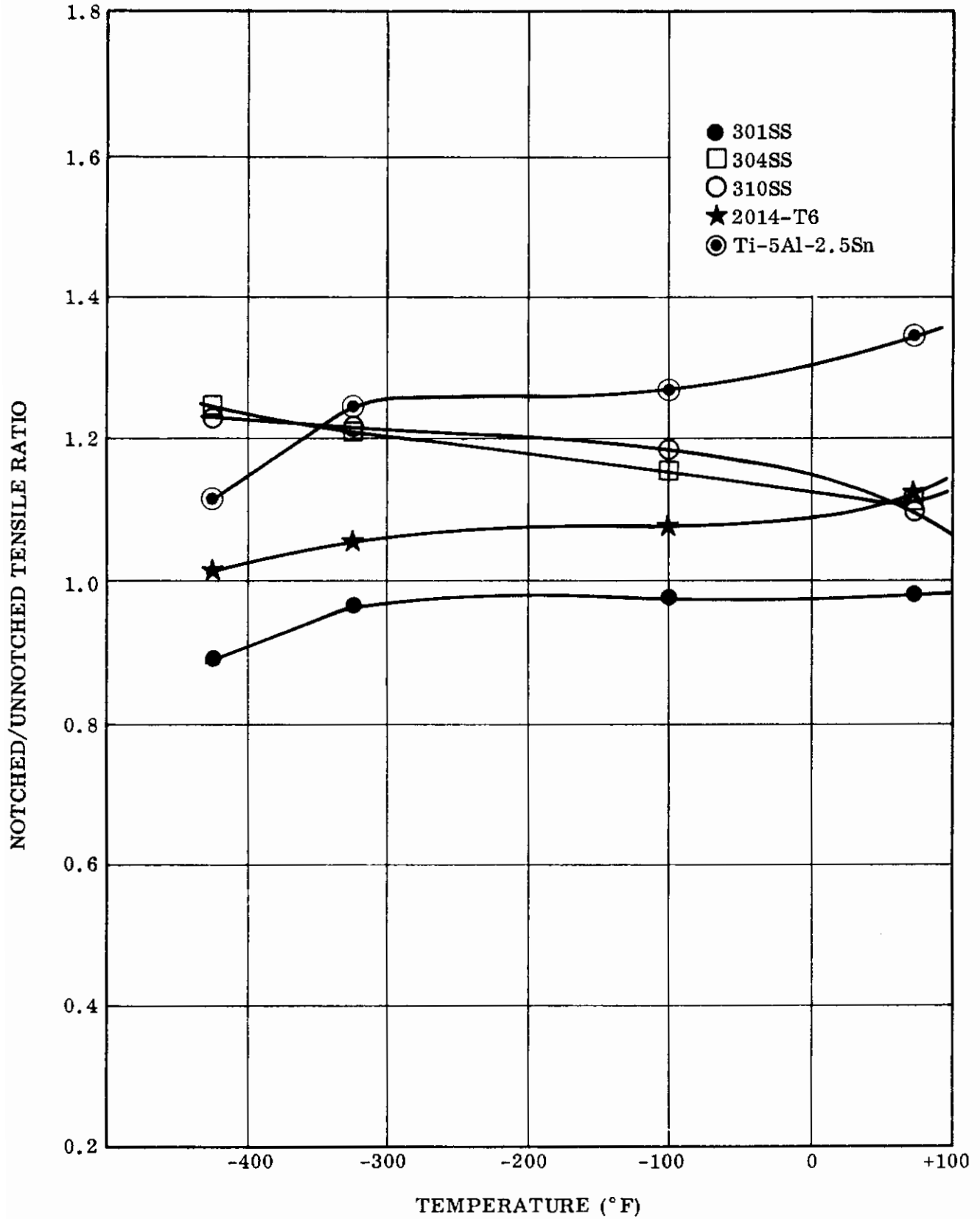

Figure 48. Notched ($K_t = 3.2$)/Unnotched Tensile Ratio Versus Temperature (Transverse)

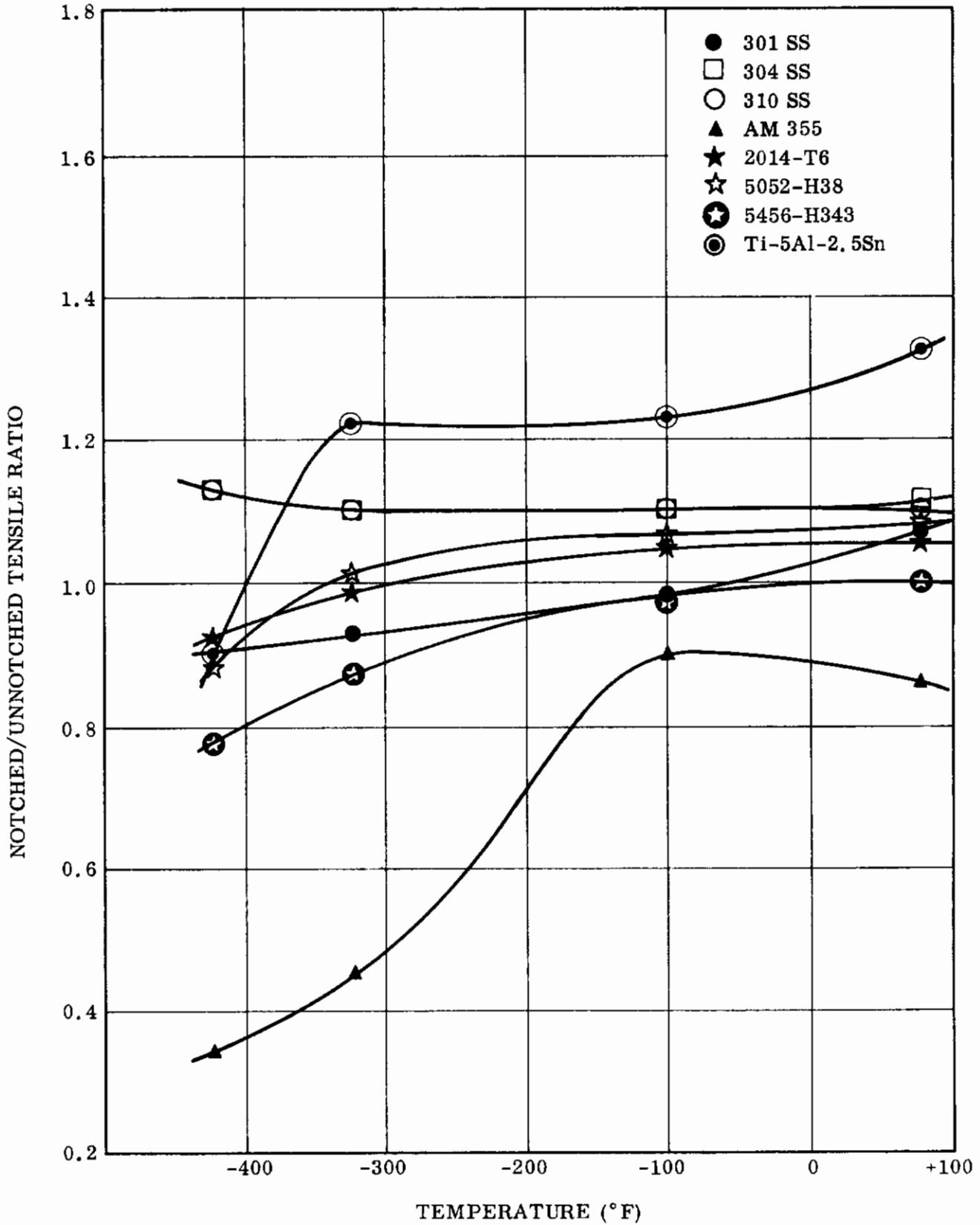

Figure 49. Notched ($K_t = 6.3$)/Unnotched Tensile Ratio Versus Temperature (Longitudinal)

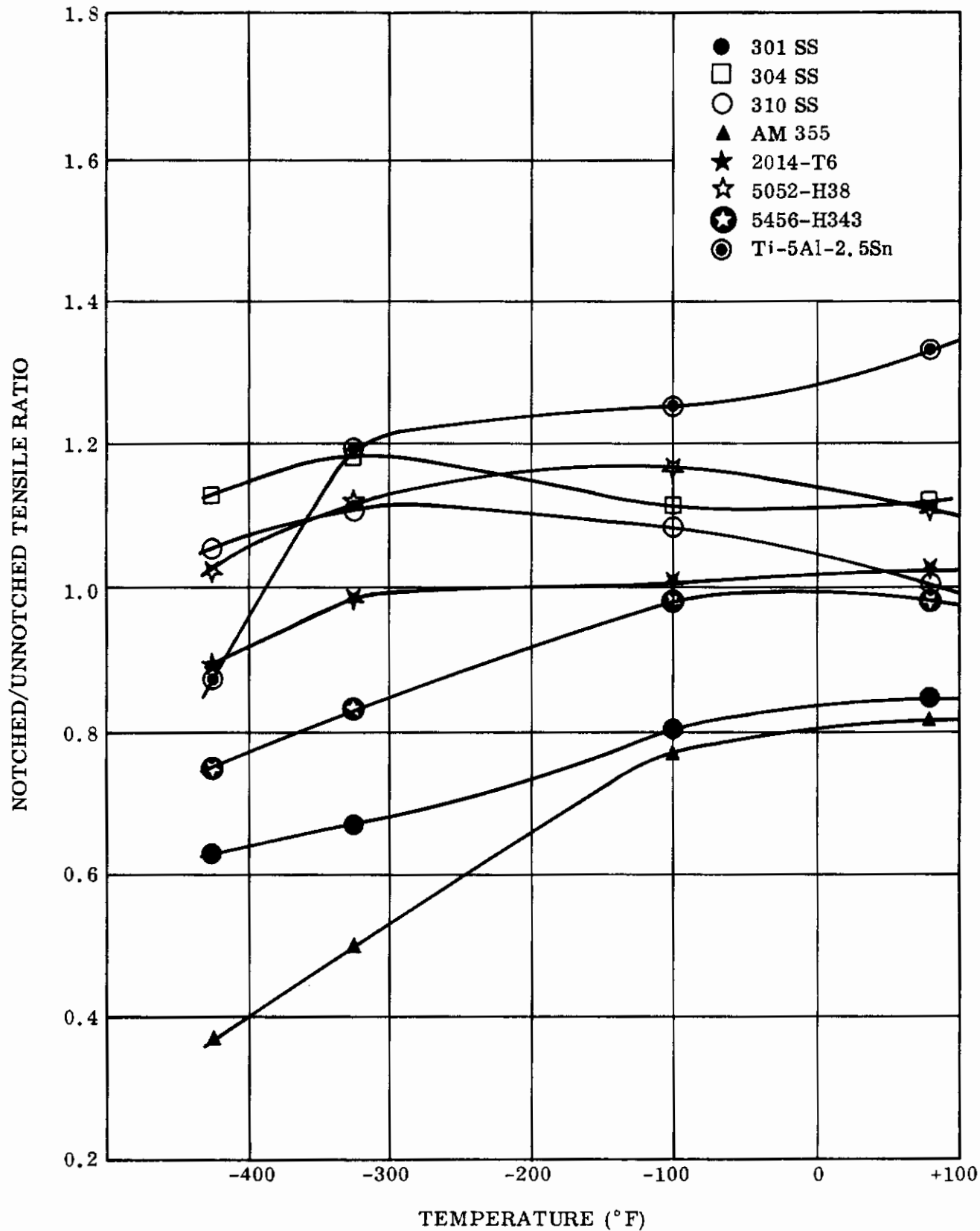

Figure 50. Notched ($K_t = 6.3$)/Unnotched Tensile Ratio Versus Temperature (Transverse)

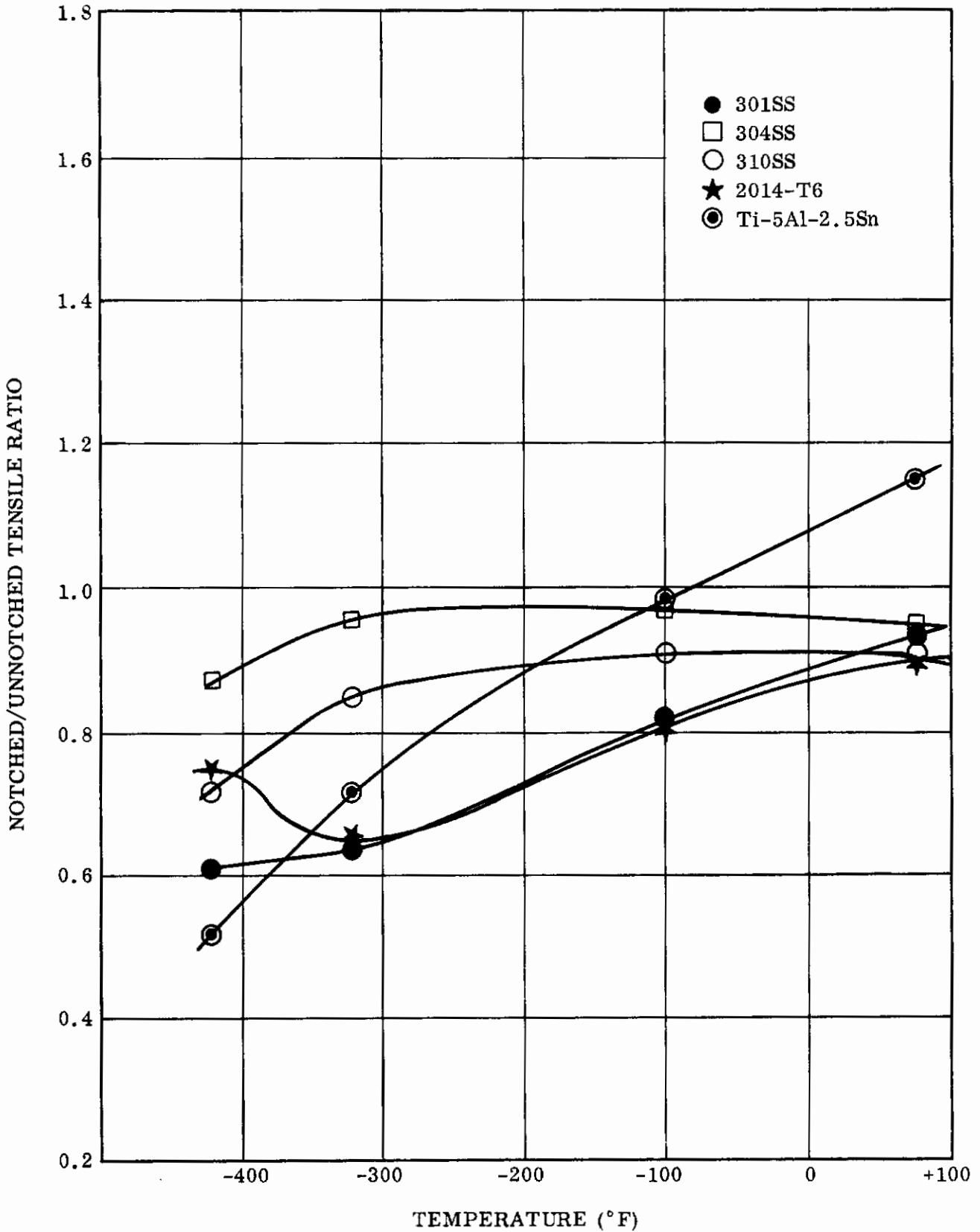

Figure 51. Notched ($K_t = 19$)/Unnotched Tensile Ratio Versus Temperature (Longitudinal)

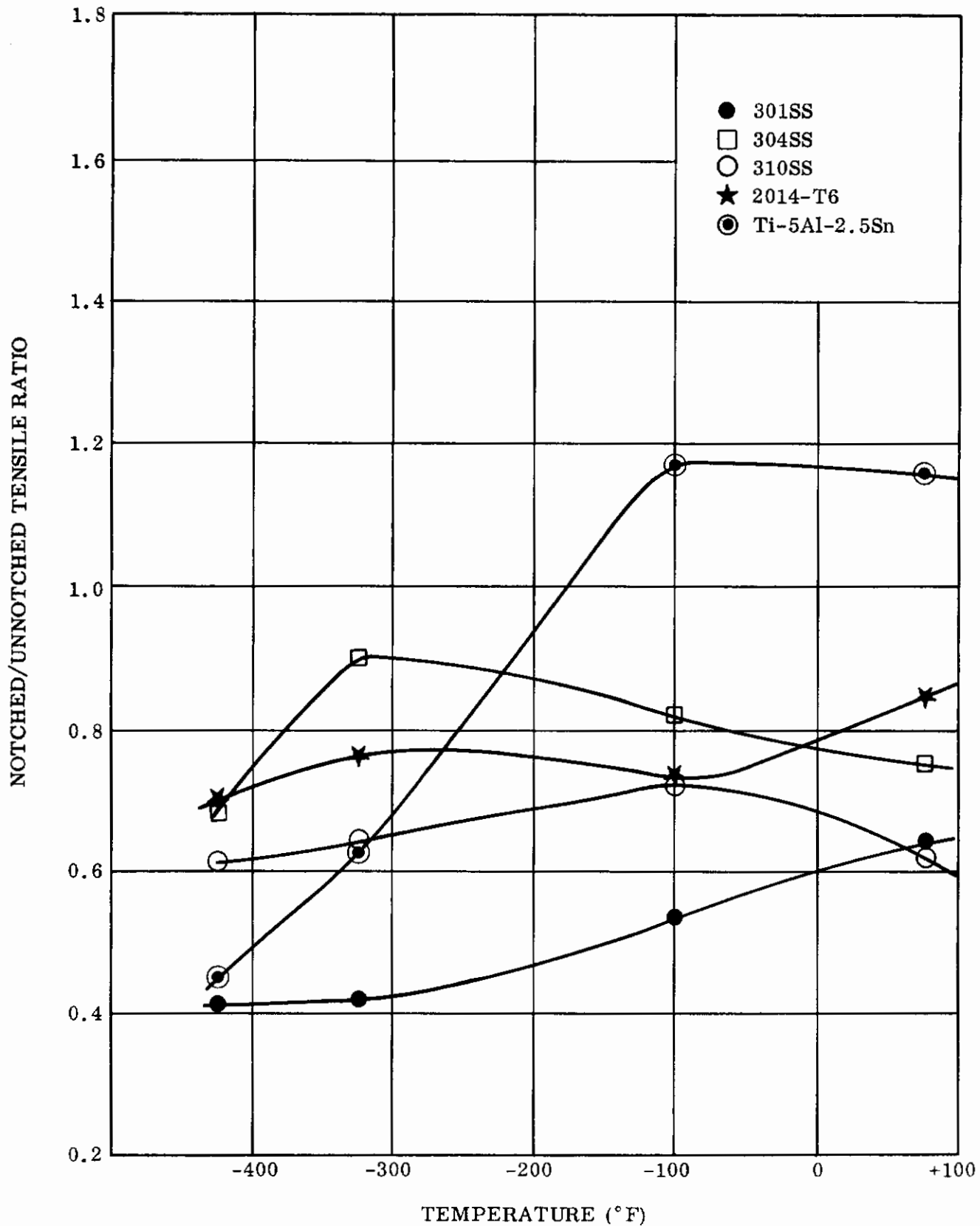

Figure 52. Notched ($K_t = 19$)/Unnotched Tensile Ratio Versus Temperature (Transverse)

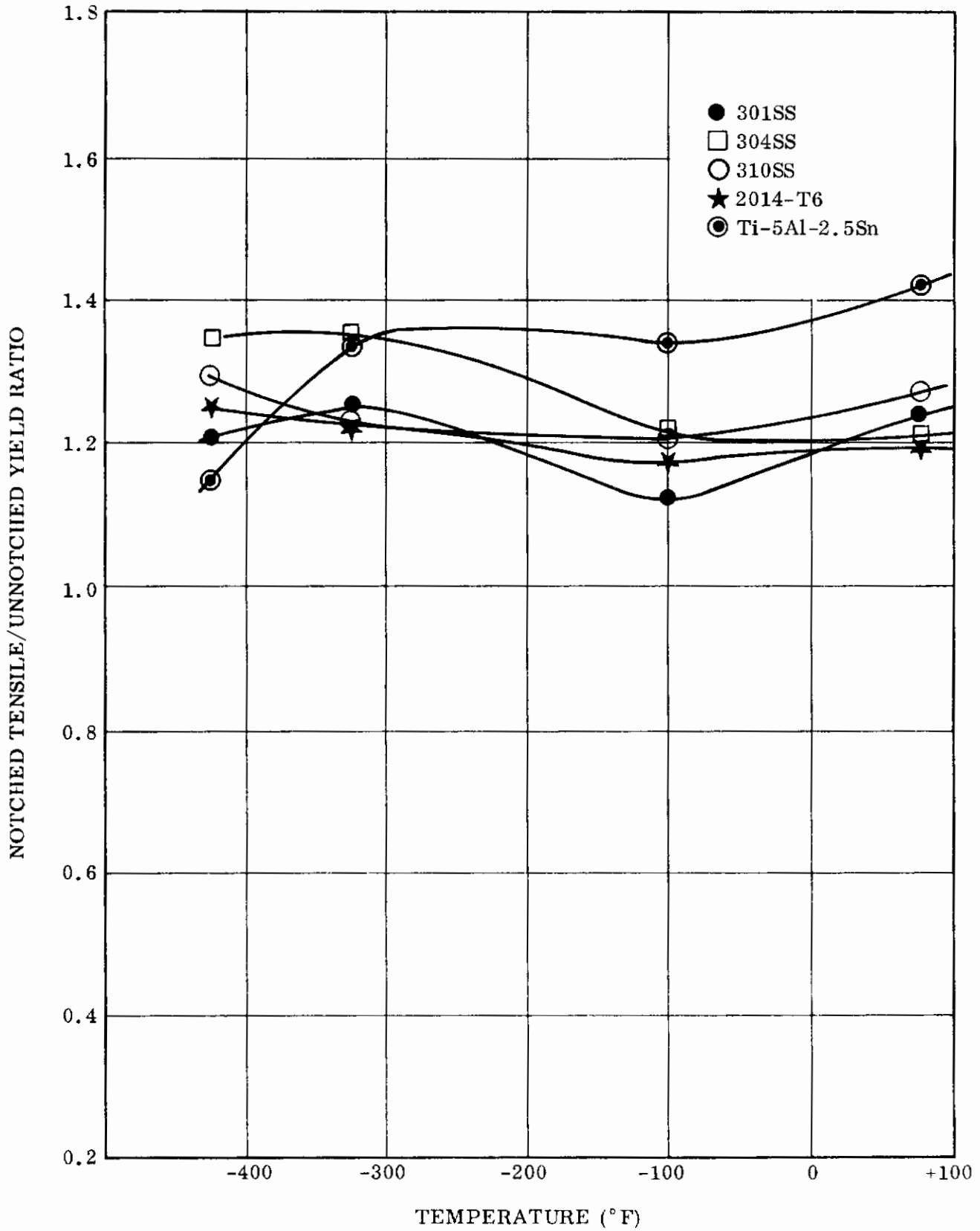

Figure 53. Notched ($K_t = 3.2$) Tensile/Unnotched Yield Ratio Versus Temperature (Longitudinal)

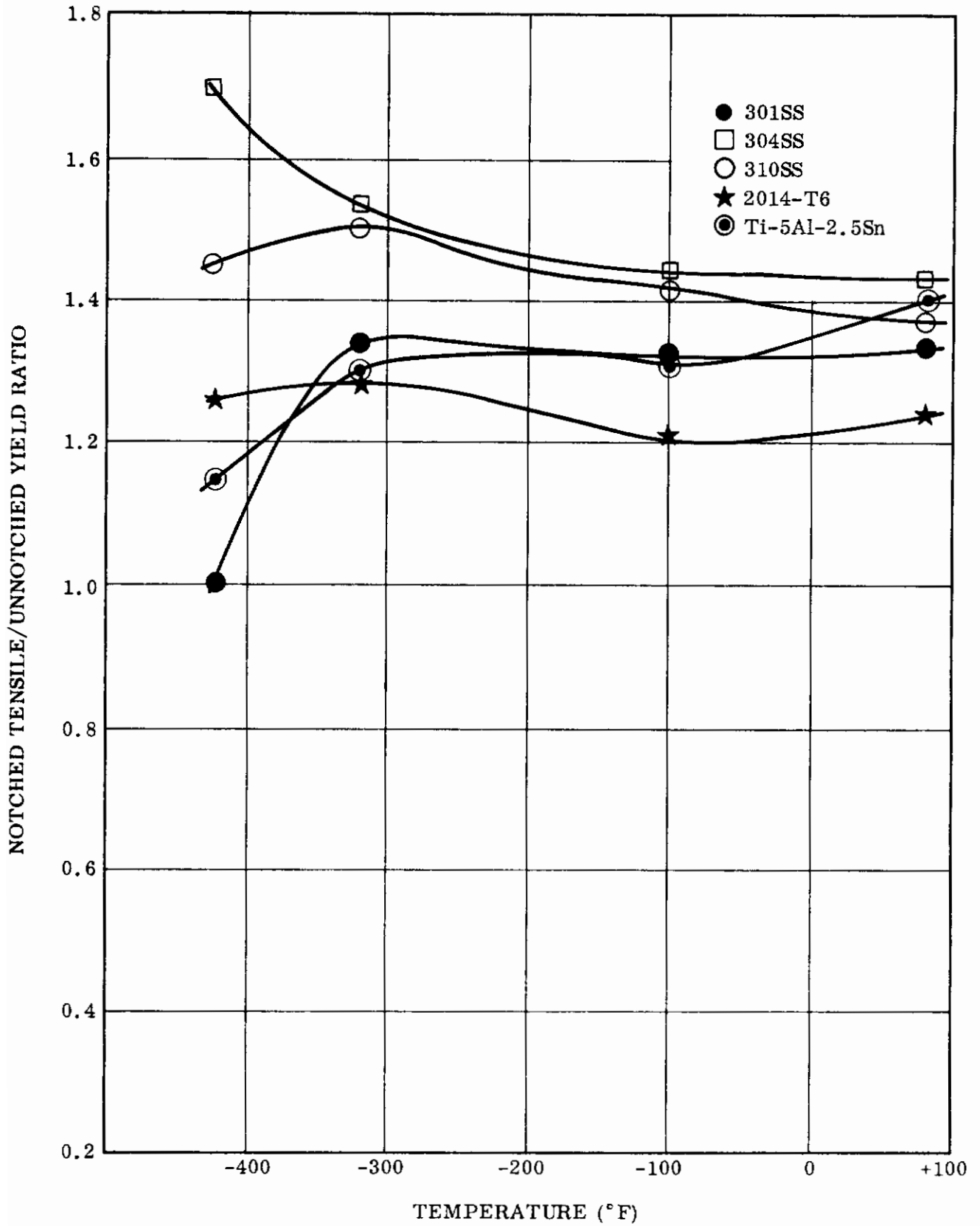

Figure 54. Notched ($K_t = 3.2$) Tensile/Unnotched Yield Ratio Versus Temperature (Transverse)

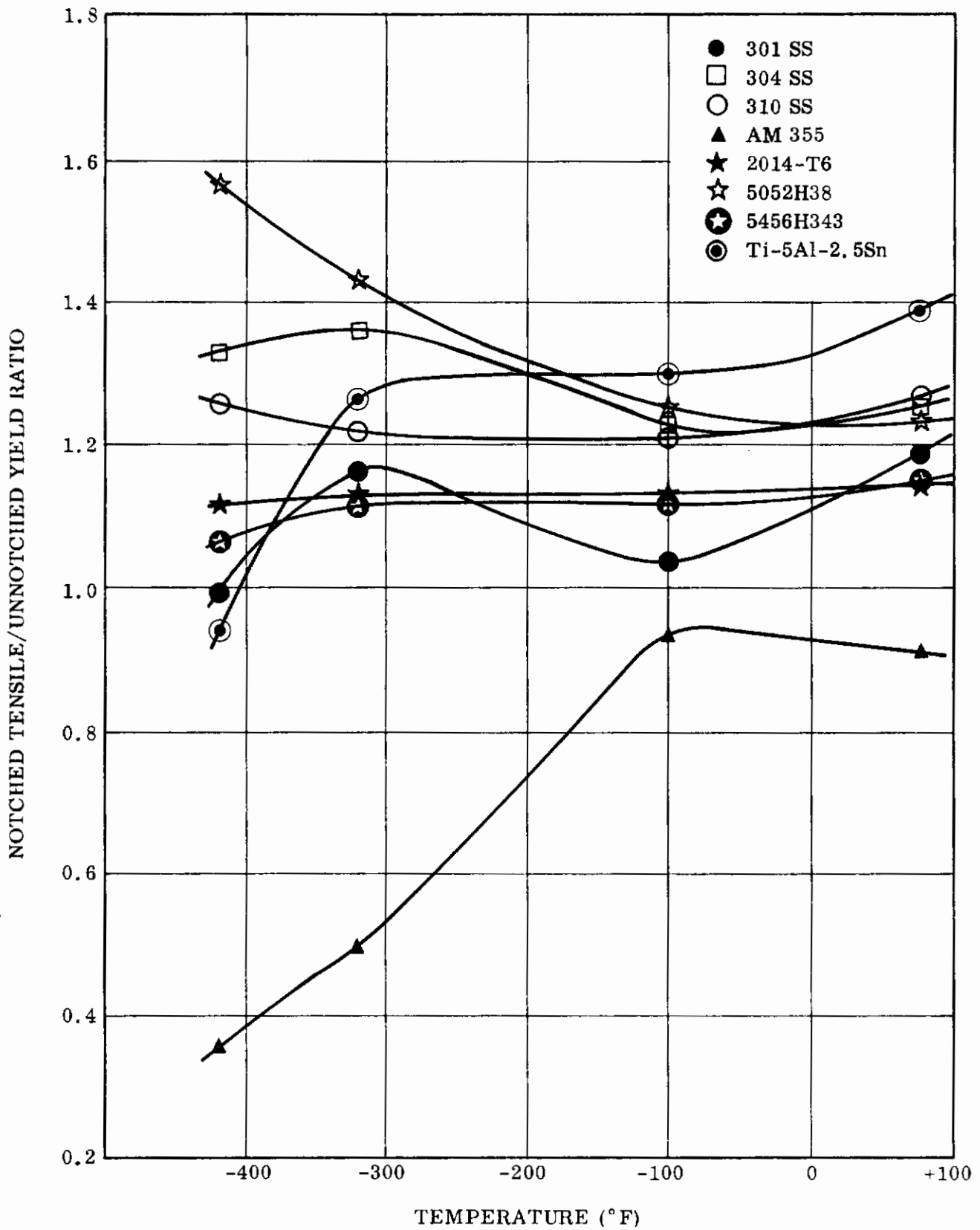

Figure 55. Notched ($K_t = 6.3$) Tensile/Unnotched Yield Ratio Versus Temperature (Longitudinal)

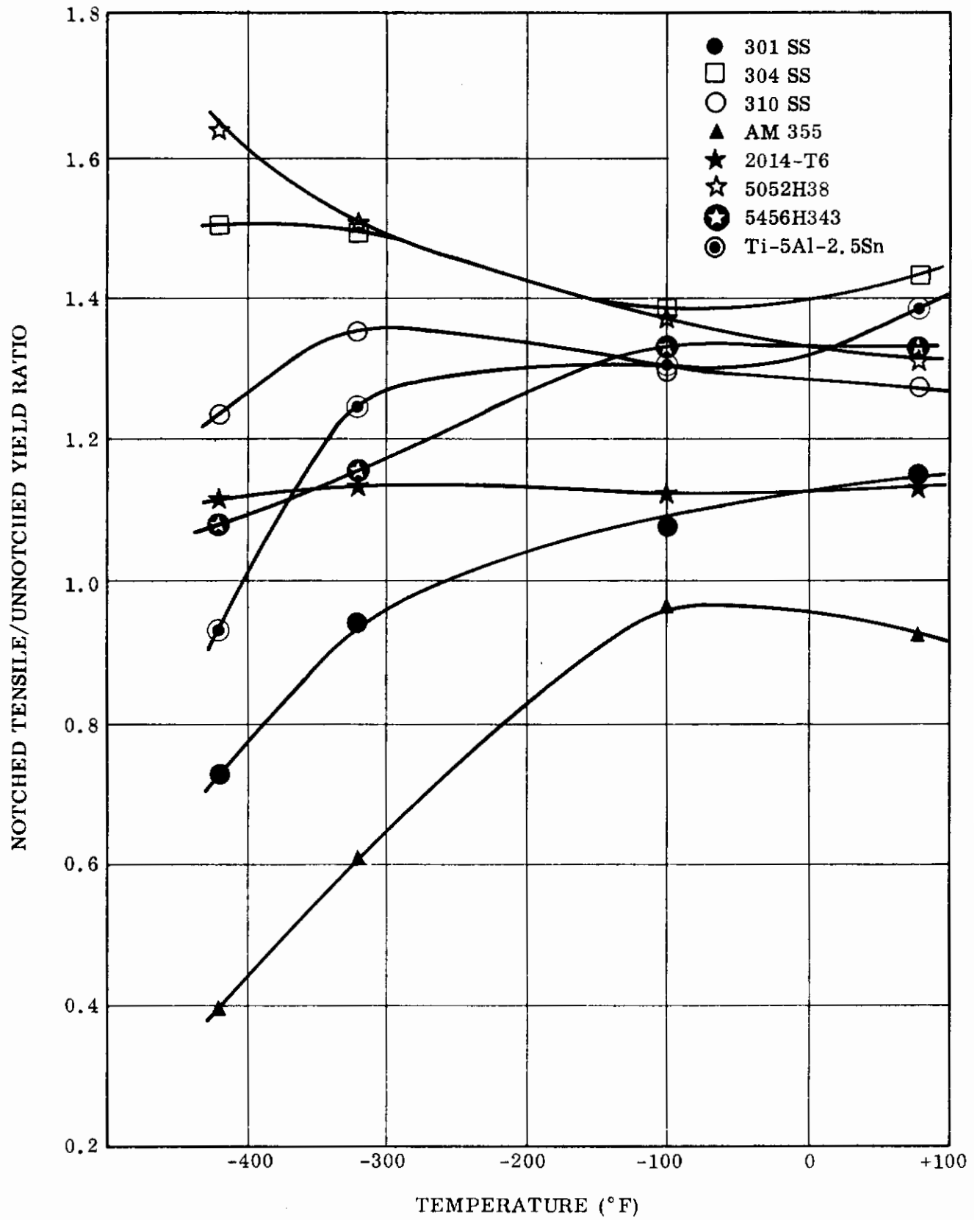

Figure 56. Notched ($K_t = 6.3$) Tensile/Unnotched Yield Ratio Versus Temperature (Transverse)

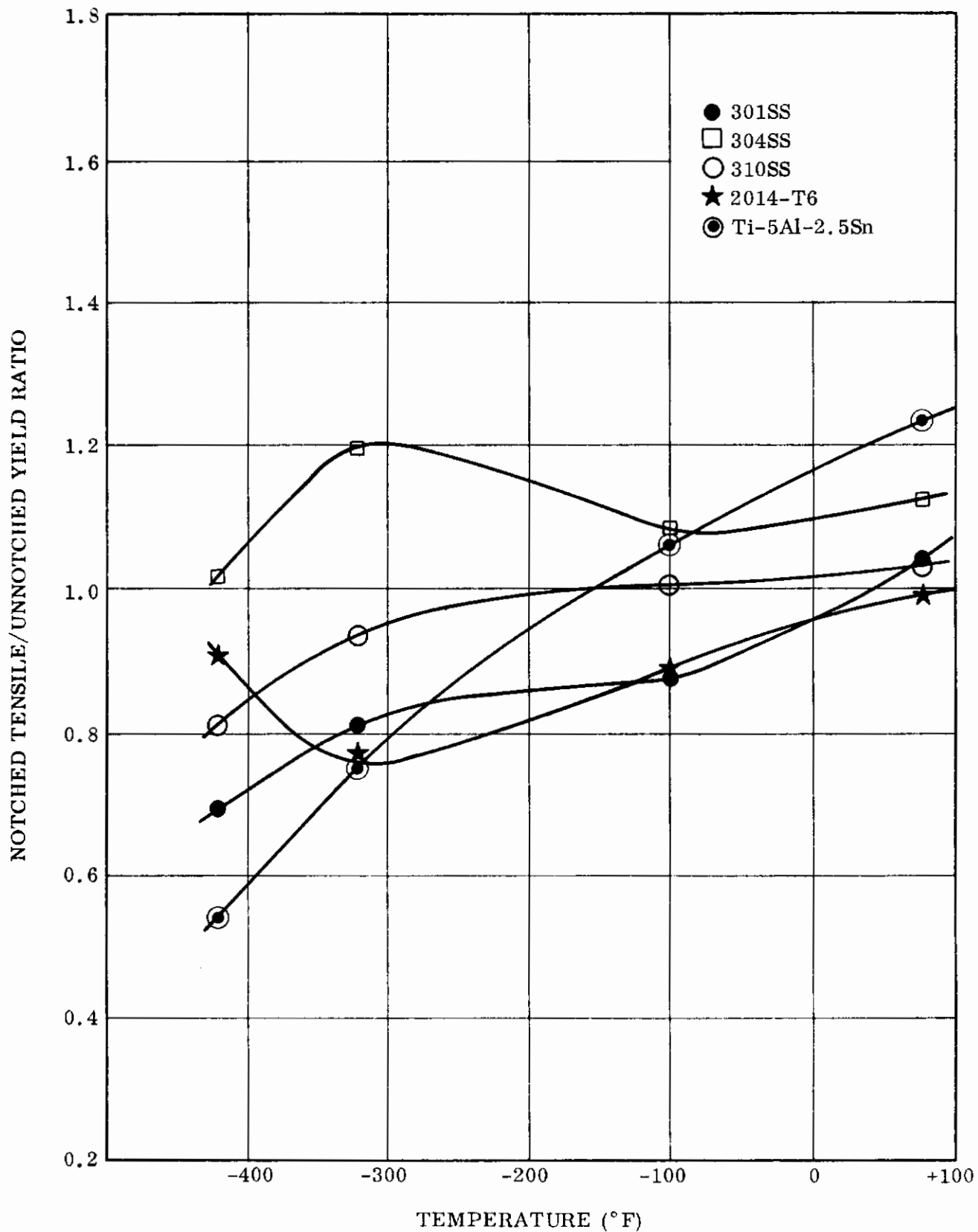

Figure 57. Notched ($K_t = 19$) Tensile/Unnotched Yield Ratio Versus Temperature (Longitudinal)

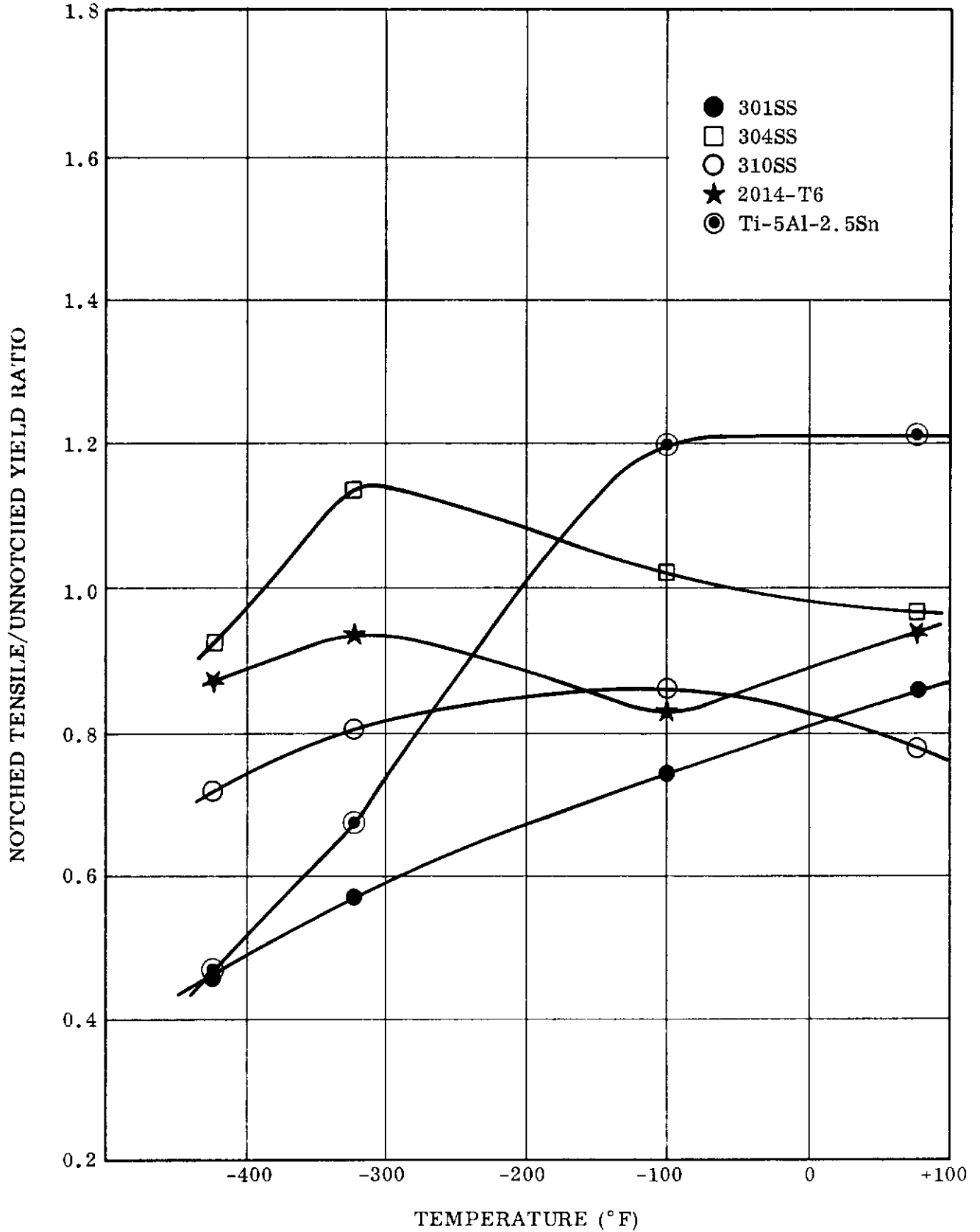

Figure 58. Notched ($K_t = 19$) Tensile/Unnotched Yield Ratio Versus Temperature (Transverse)

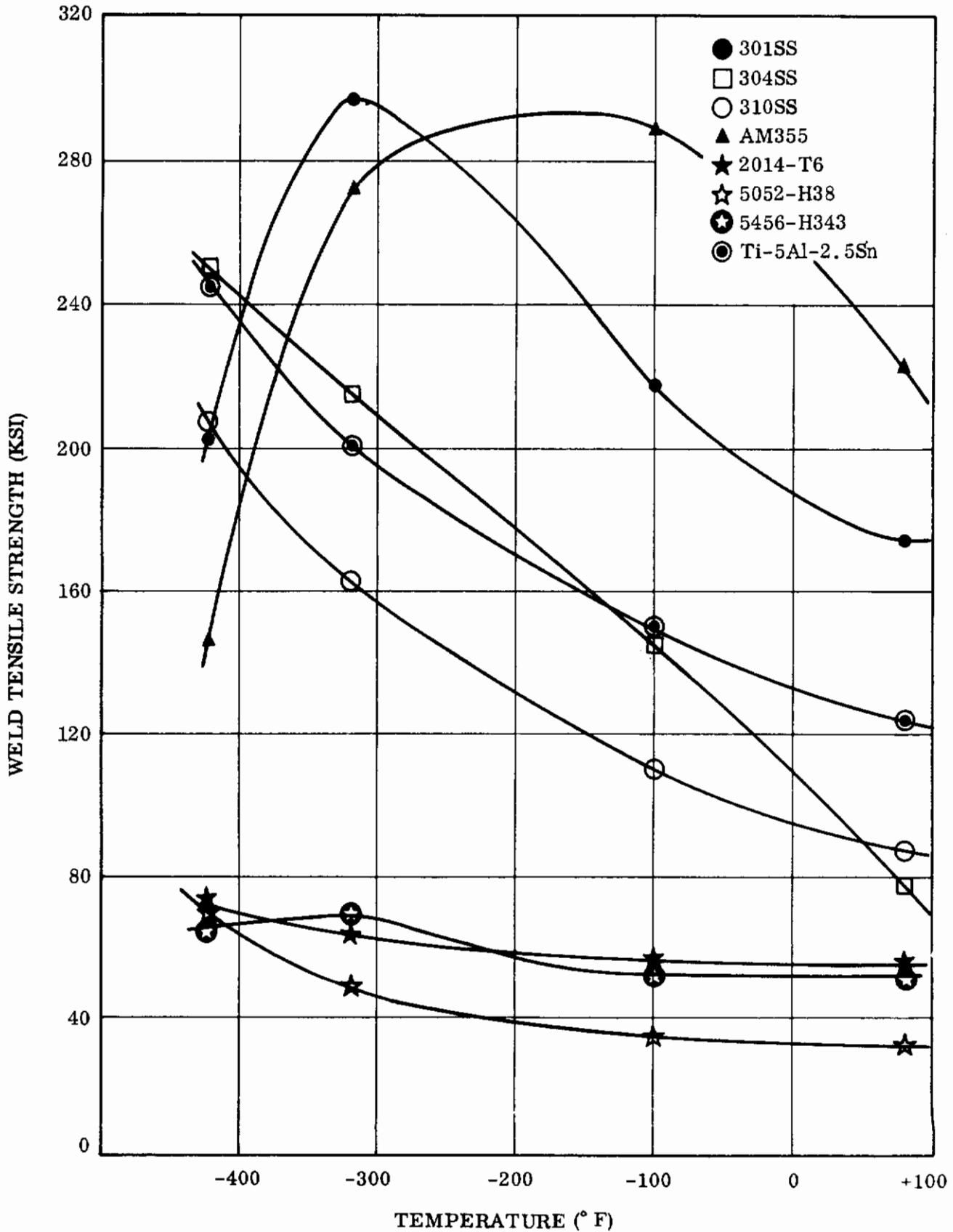

Figure 59. Weld Tensile Strength Versus Temperature (Longitudinal)

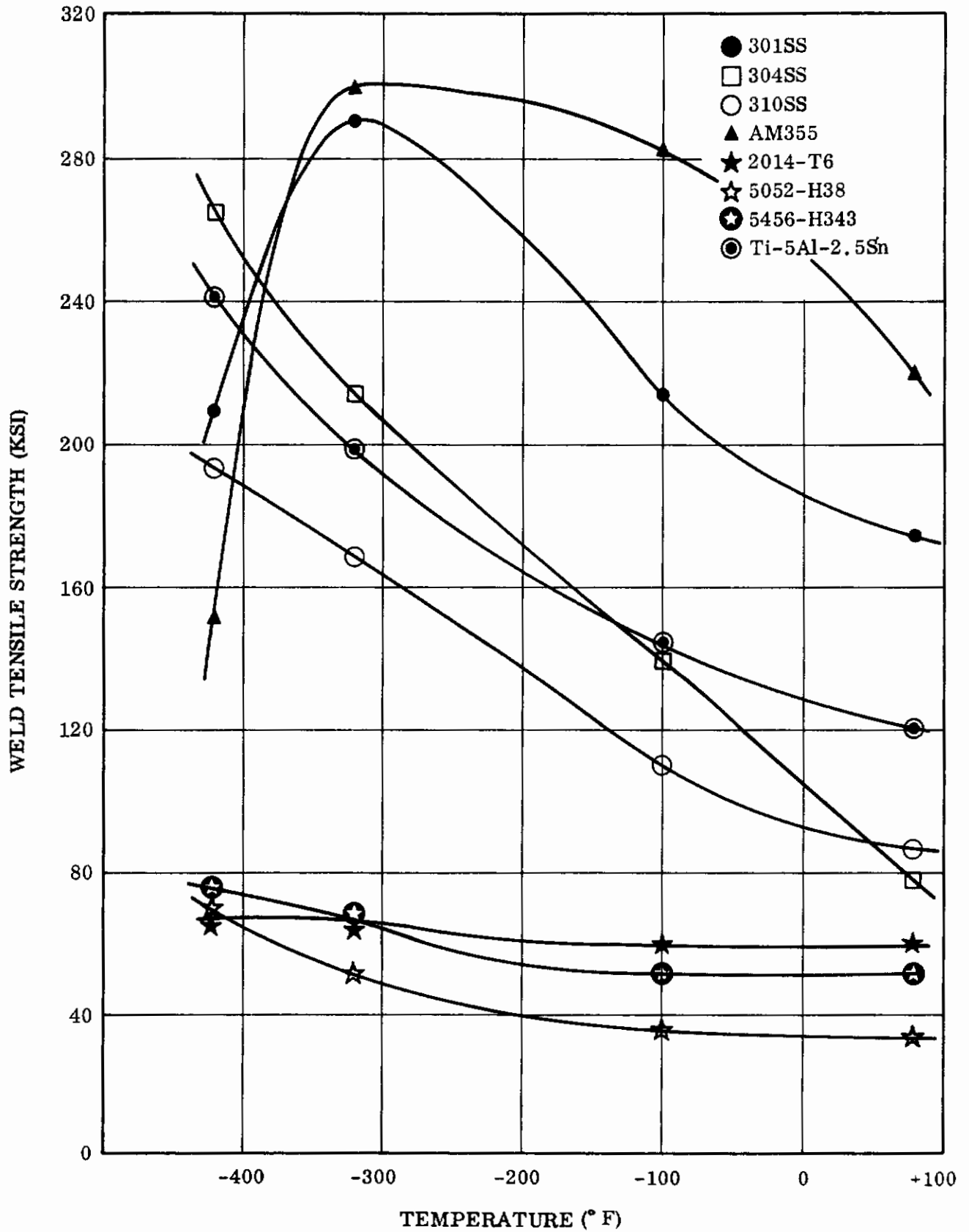

Figure 60. Weld Tensile Strength Versus Temperature (Transverse)

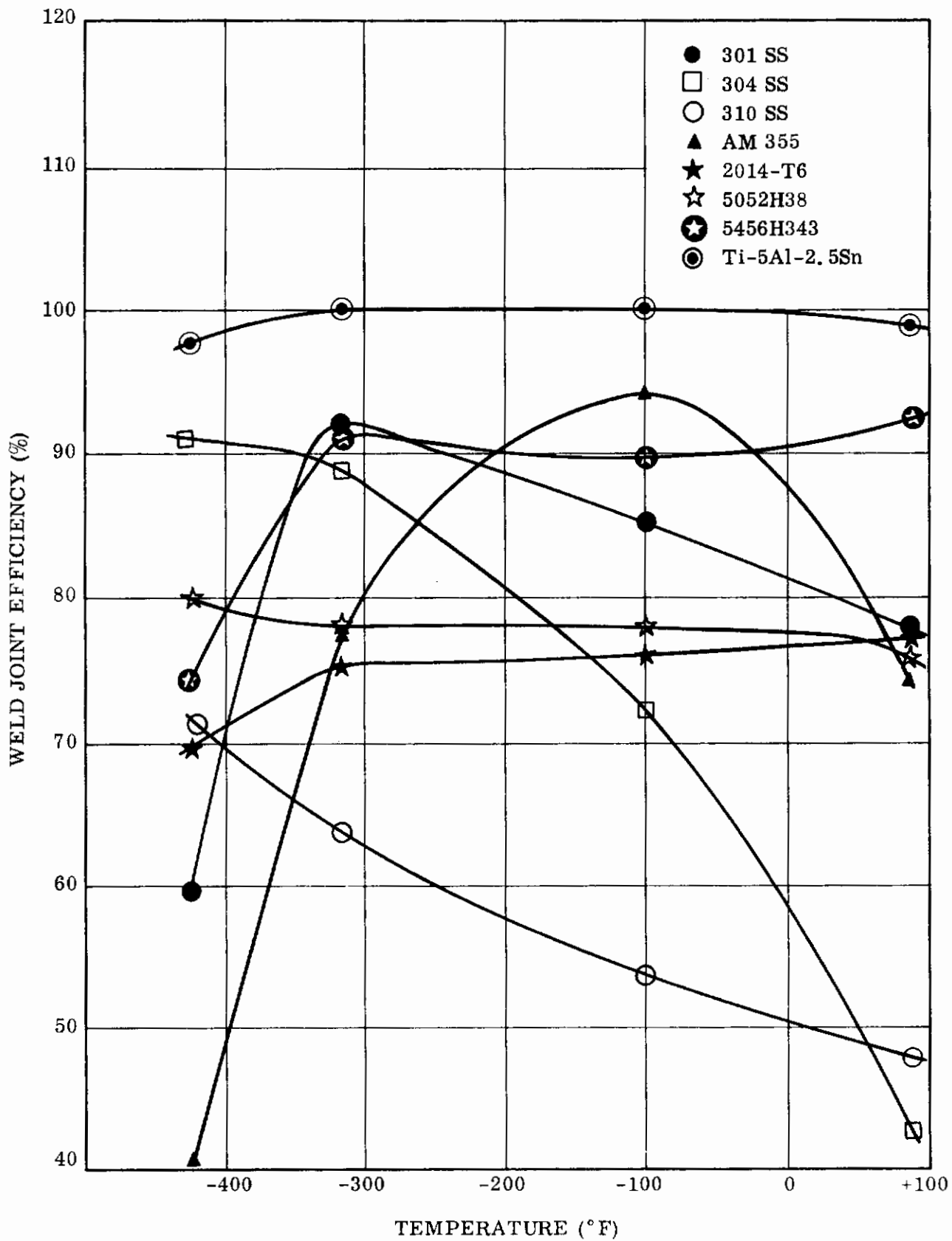

Figure 61. Weld Joint Efficiency Versus Temperature (Longitudinal)

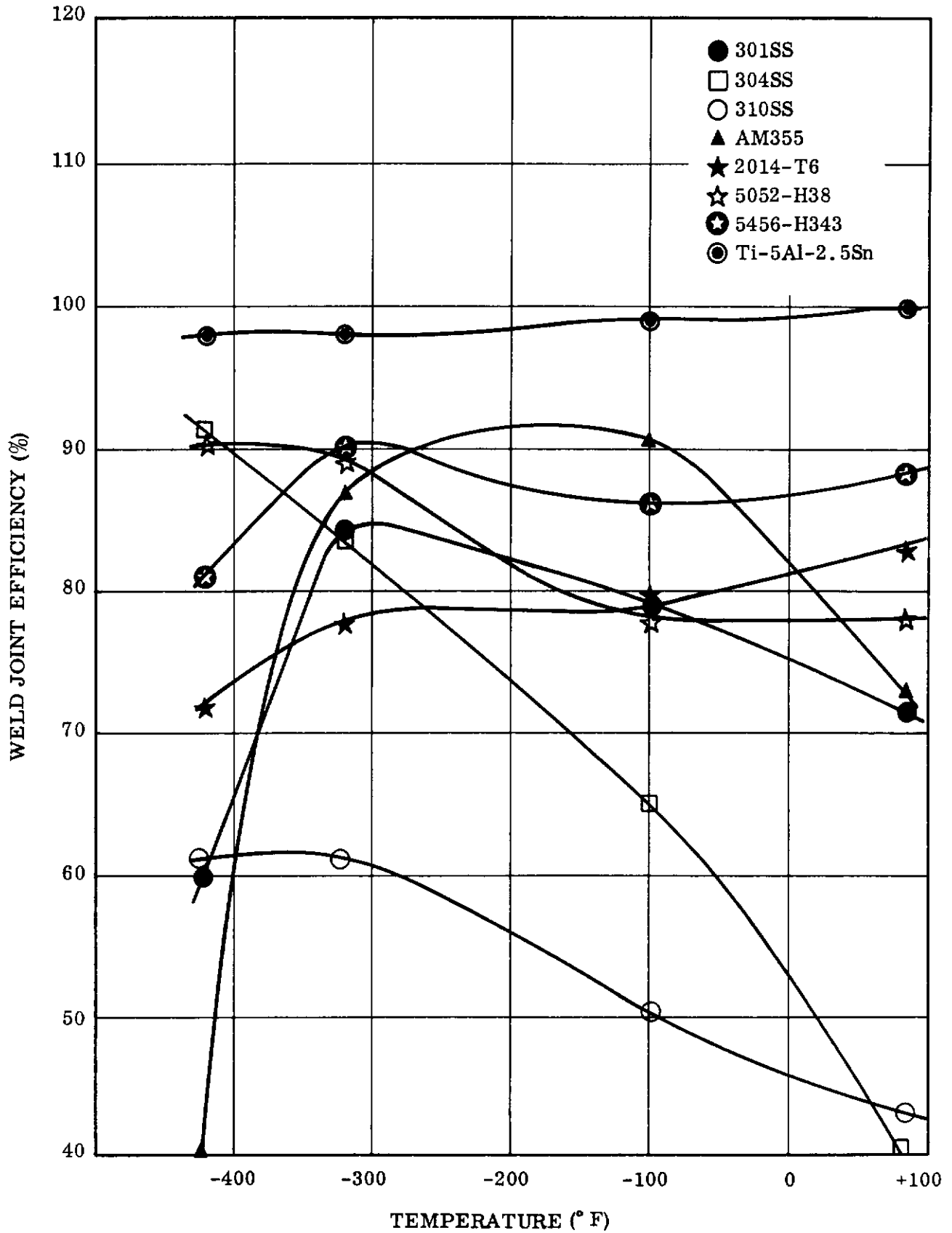

Figure 62. Weld Joint Efficiency Versus Temperature (Transverse)

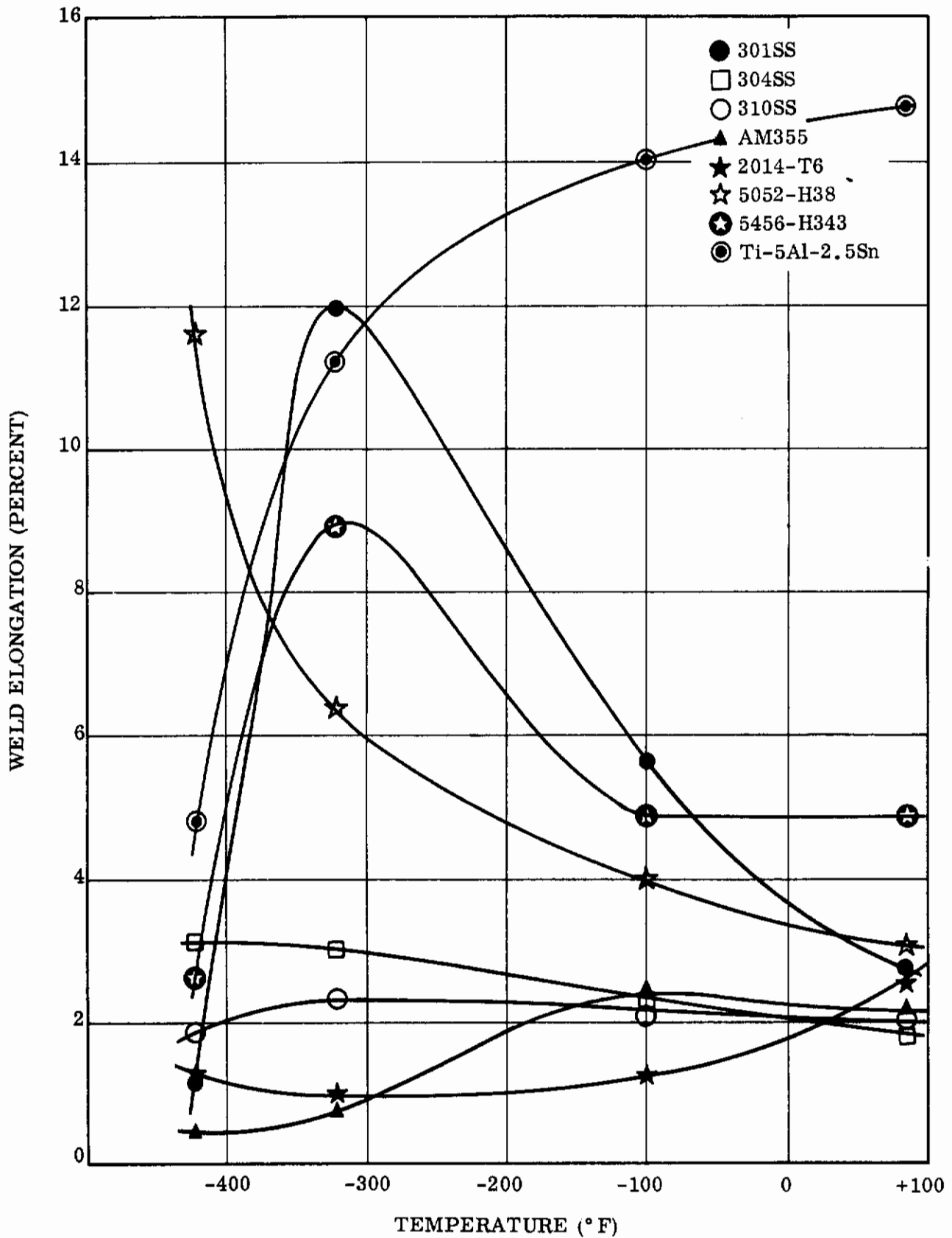

Figure 63. Weld Elongation Versus Temperature (Longitudinal)

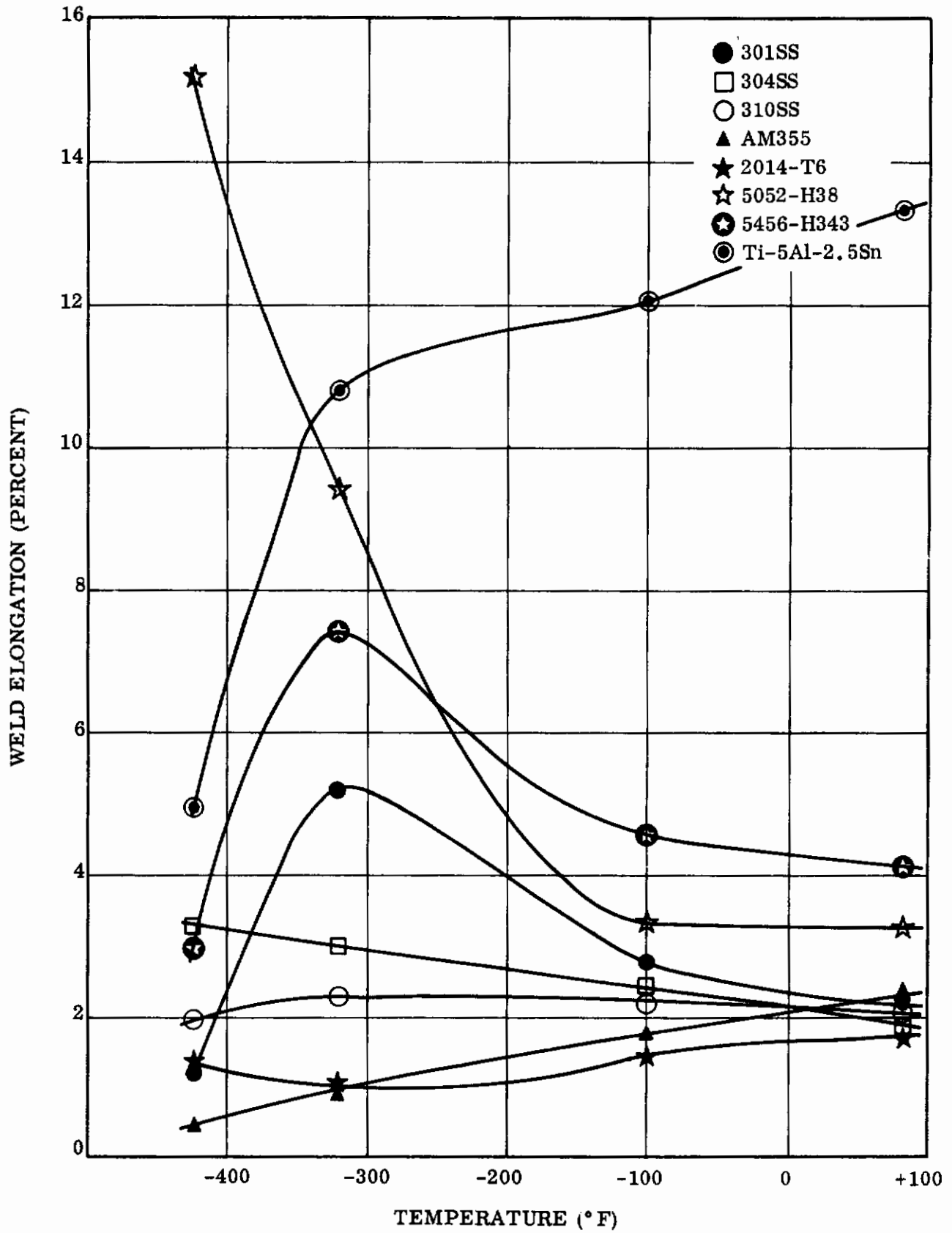

Figure 64. Weld Elongation Versus Temperature (Transverse)

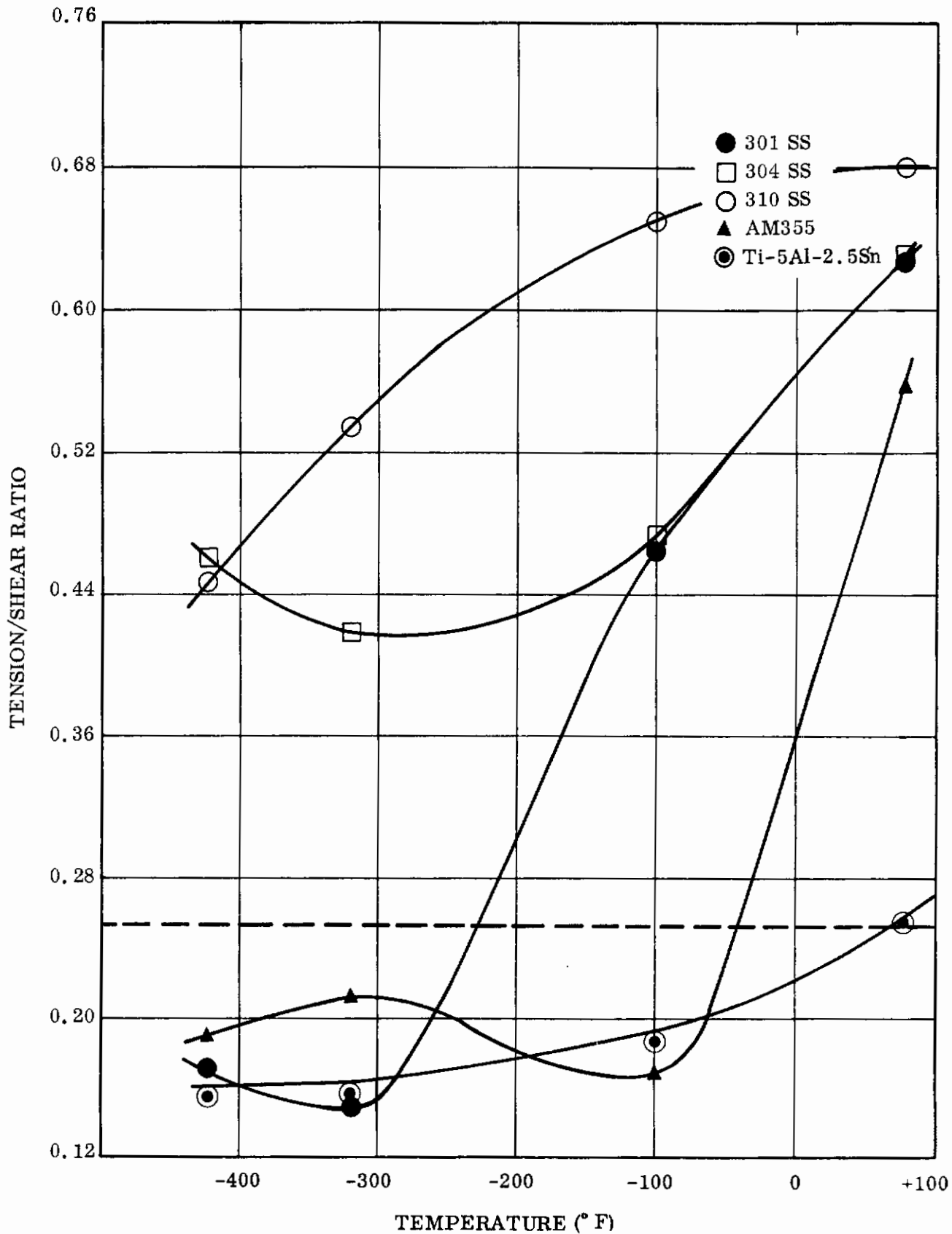

Figure 65. Tension/Shear Ratio of Spot Welds Versus Temperature

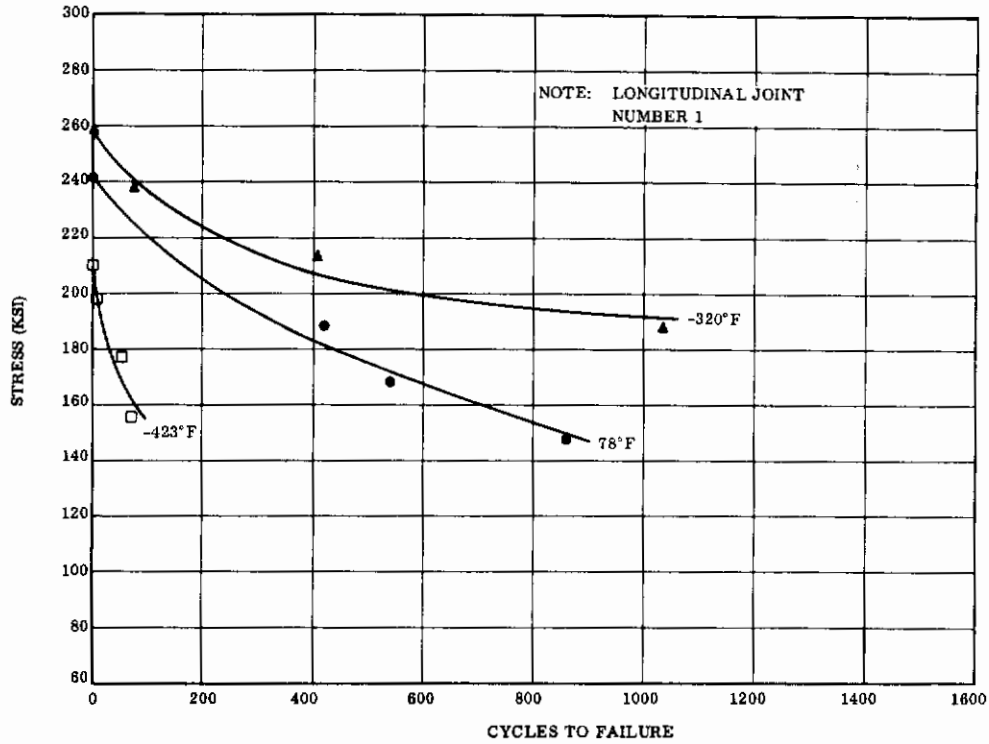

Figure 66. S-N Curve - 301 Stainless Steel (Longitudinal - Joint No. 1)

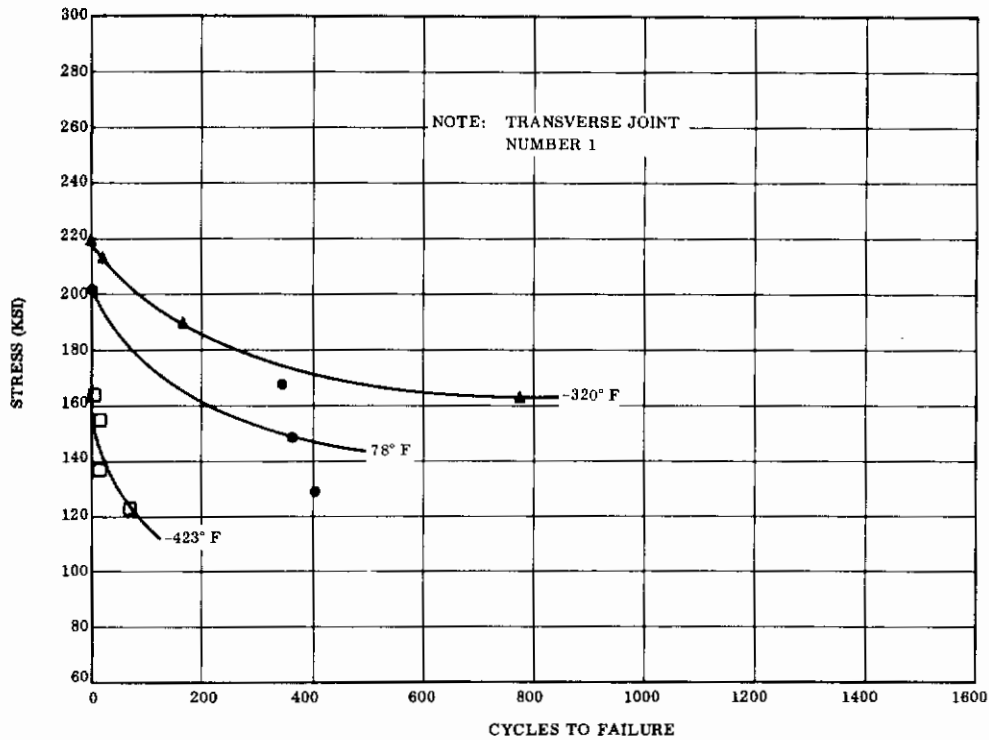

Figure 67. S-N Curve - 301 Stainless Steel (Transverse Joint No. 1)

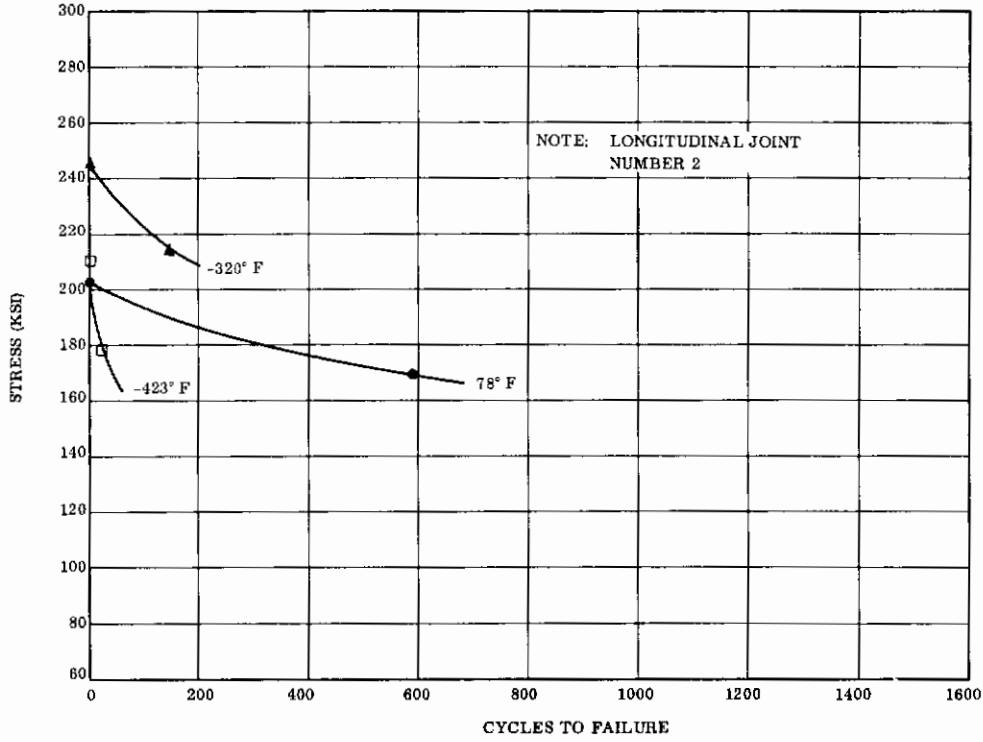

Figure 68. S-N Curve - 301 Stainless Steel (Longitudinal - Joint No. 2)

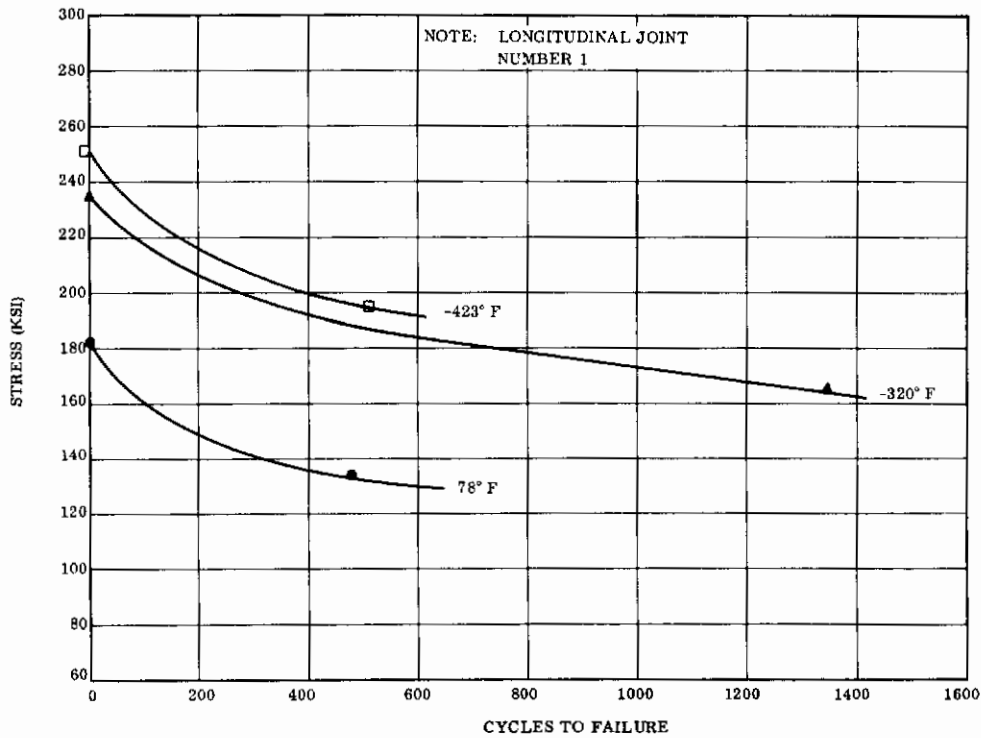

Figure 69. S-N Curve - 304 ELC Stainless Steel (Longitudinal - Joint No. 1)

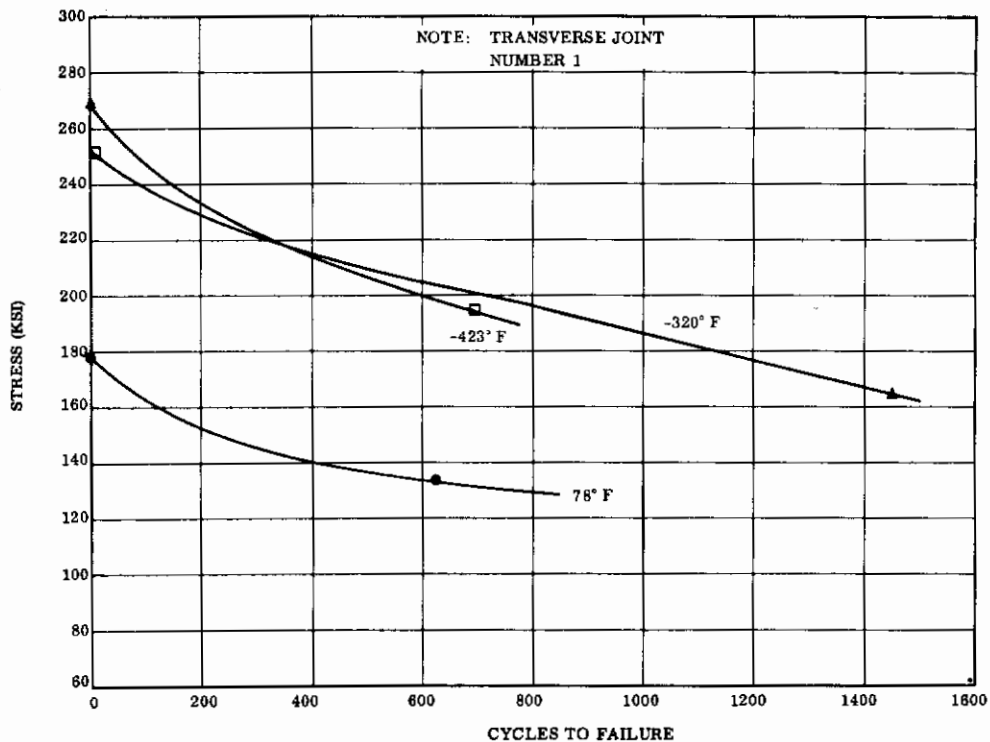

Figure 70. S-N Curve - 304 ELC Stainless Steel (Transverse - Joint No. 1)

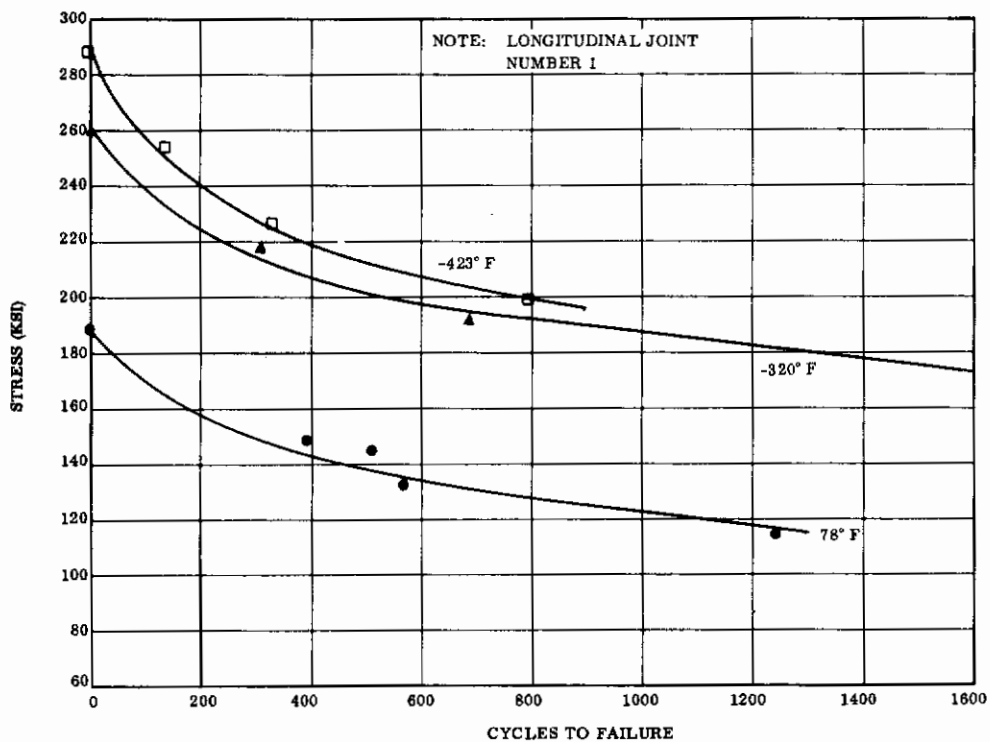

Figure 71. S-N Curve - 310 Stainless Steel (Longitudinal - Joint No. 1)

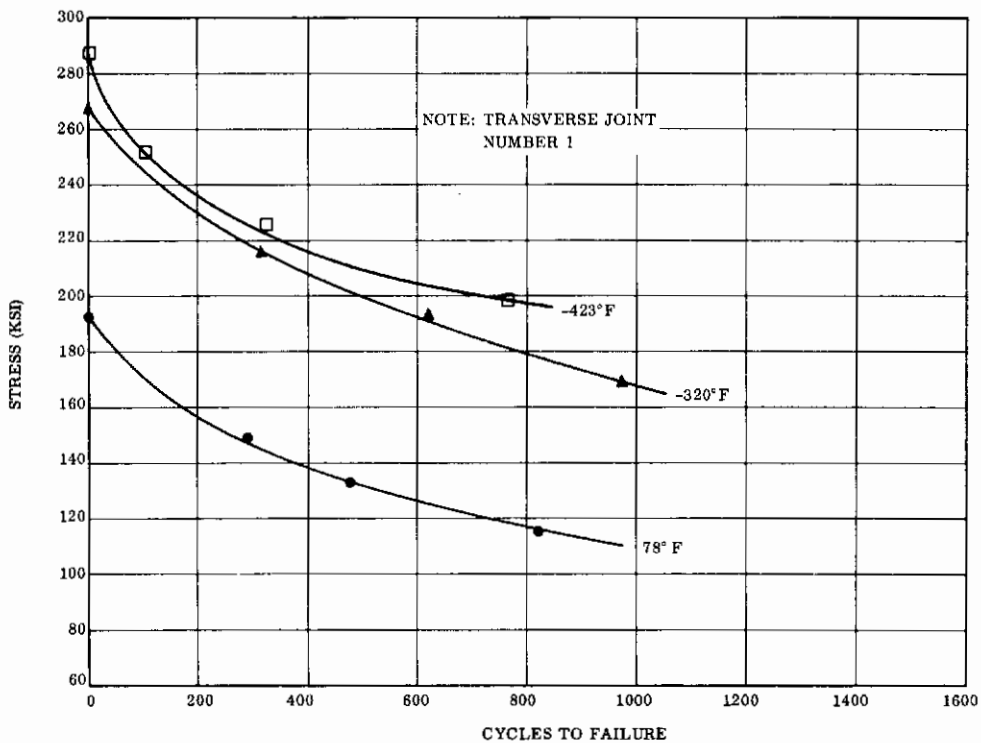

Figure 72. S-N Curve - 310 Stainless Steel (Transverse - Joint No. 1)

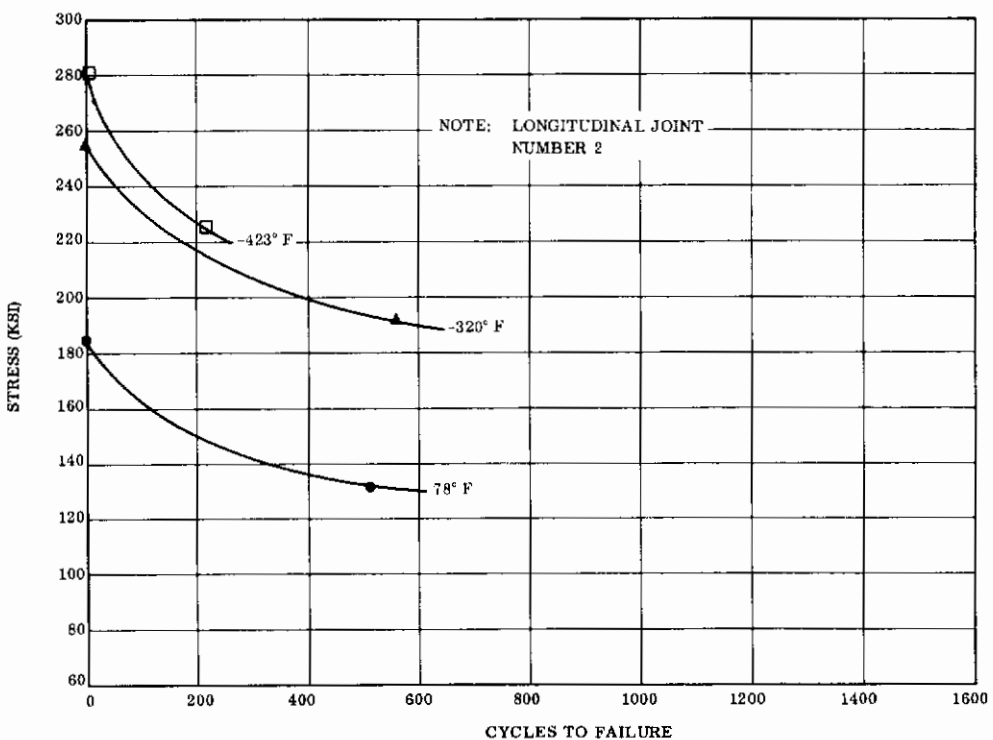

Figure 73. S-N Curve - 310 Stainless Steel (Longitudinal - Joint No. 2)

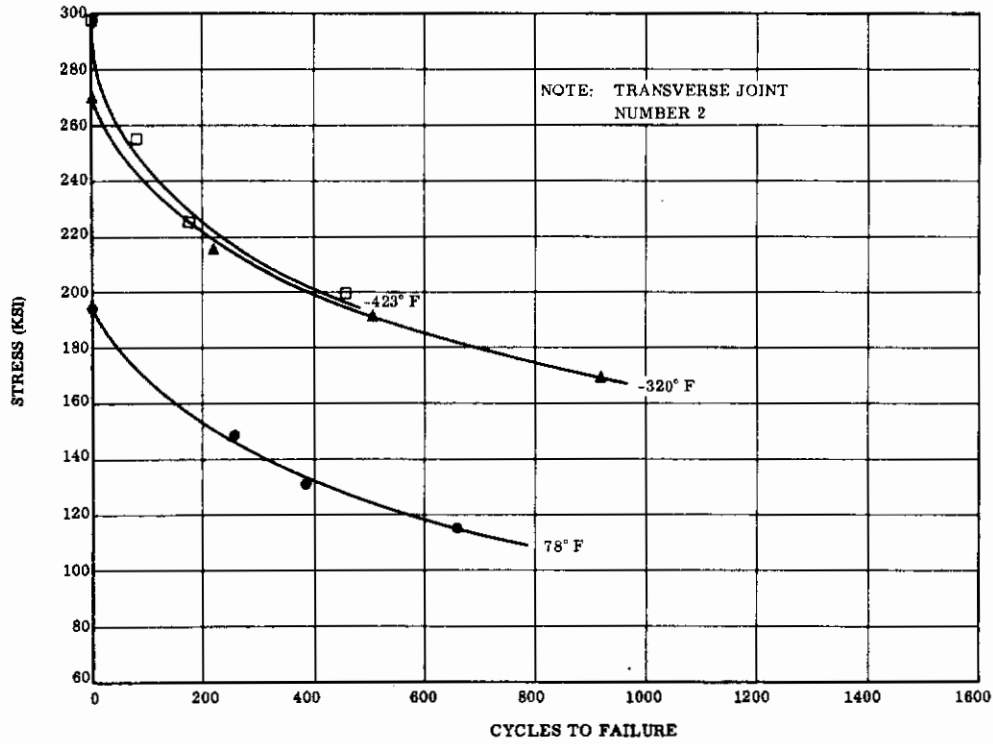

Figure 74. S-N Curve - 310 Stainless Steel (Transverse - Joint No. 2)

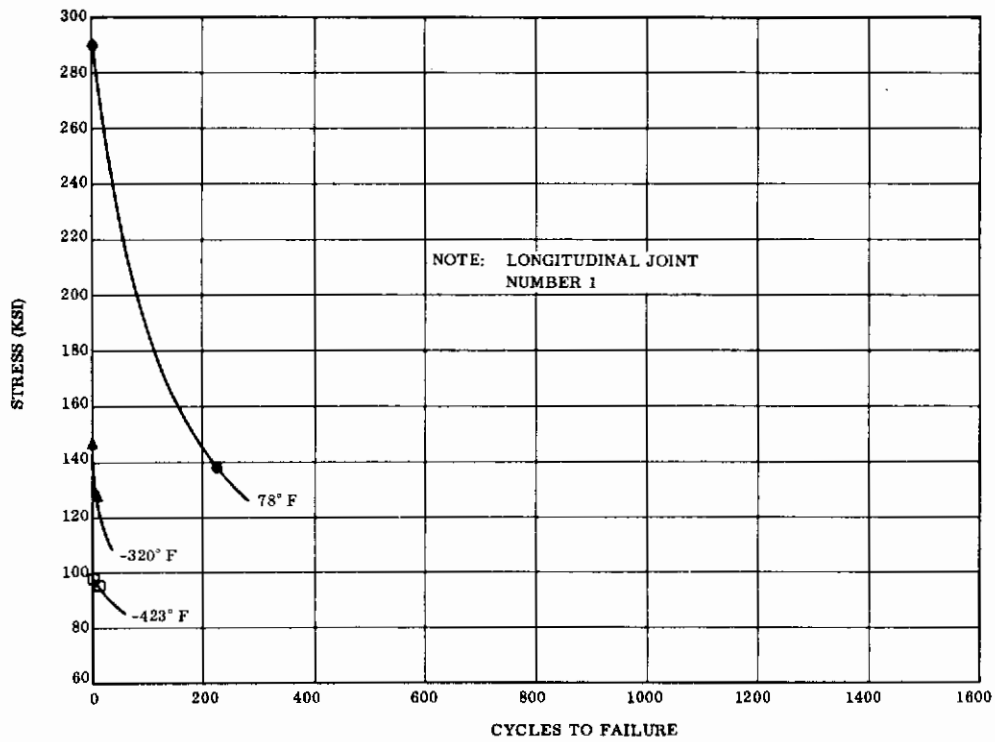

Figure 75. S-N Curve - AM-355 Stainless Steel (Longitudinal - Joint No. 1)

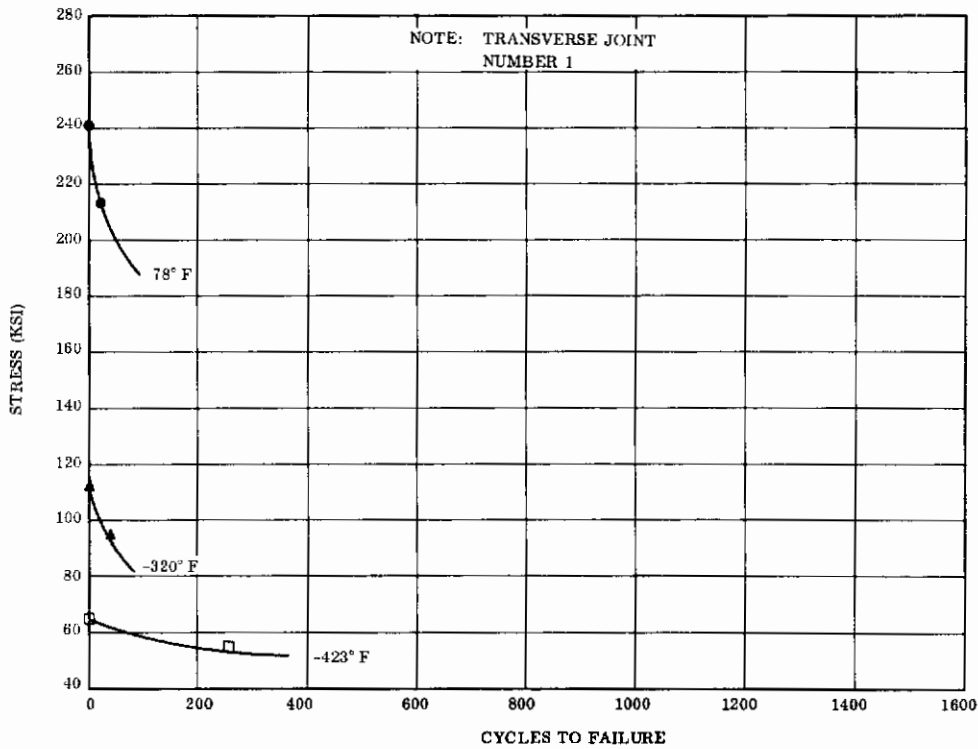

Figure 76. S-N Curve - AM-355 Stainless Steel (Transverse - Joint No. 1)

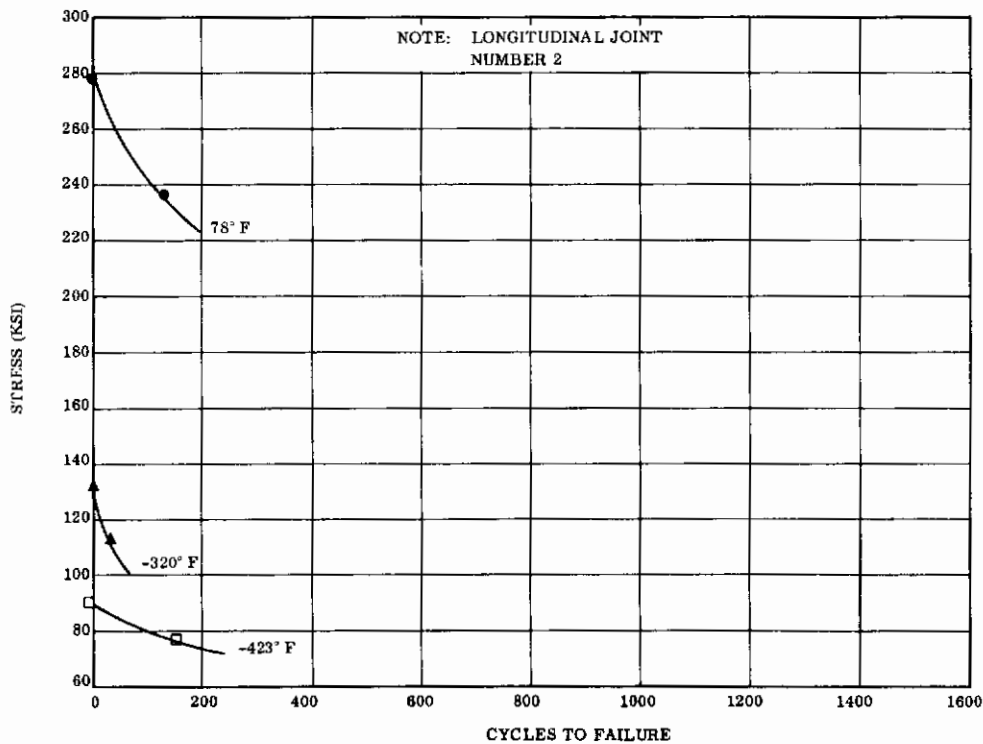

Figure 77. S-N Curve - AM-355 Stainless Steel (Longitudinal - Joint No. 2)

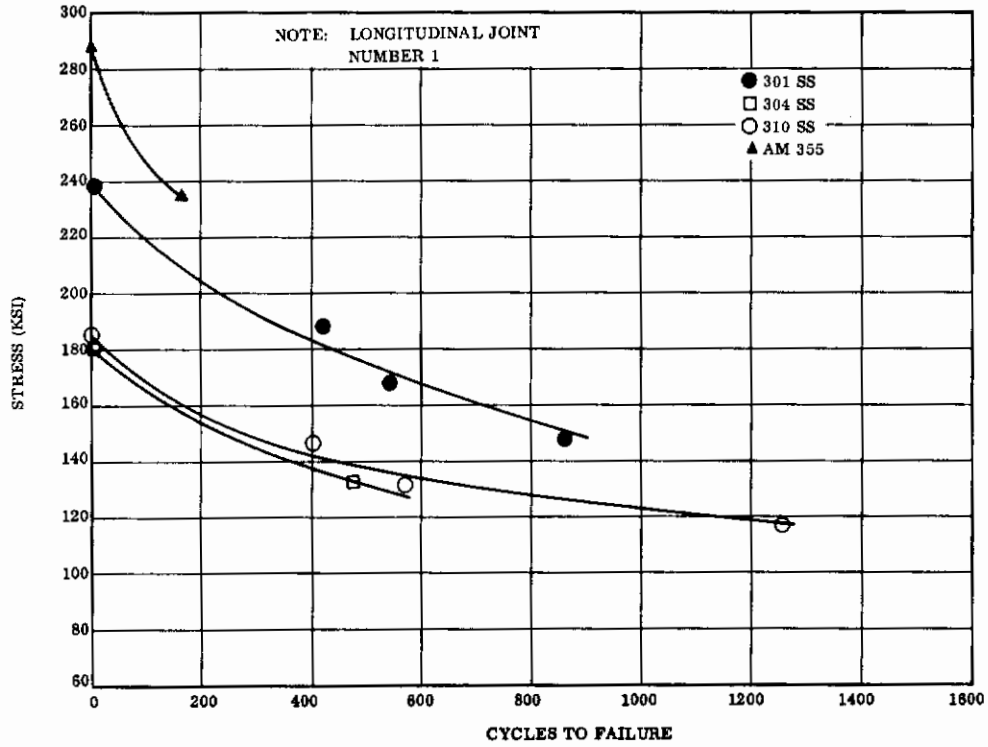

Figure 78. S-N Curve - Stainless Steels at 78°F (Longitudinal - Joint No. 1)

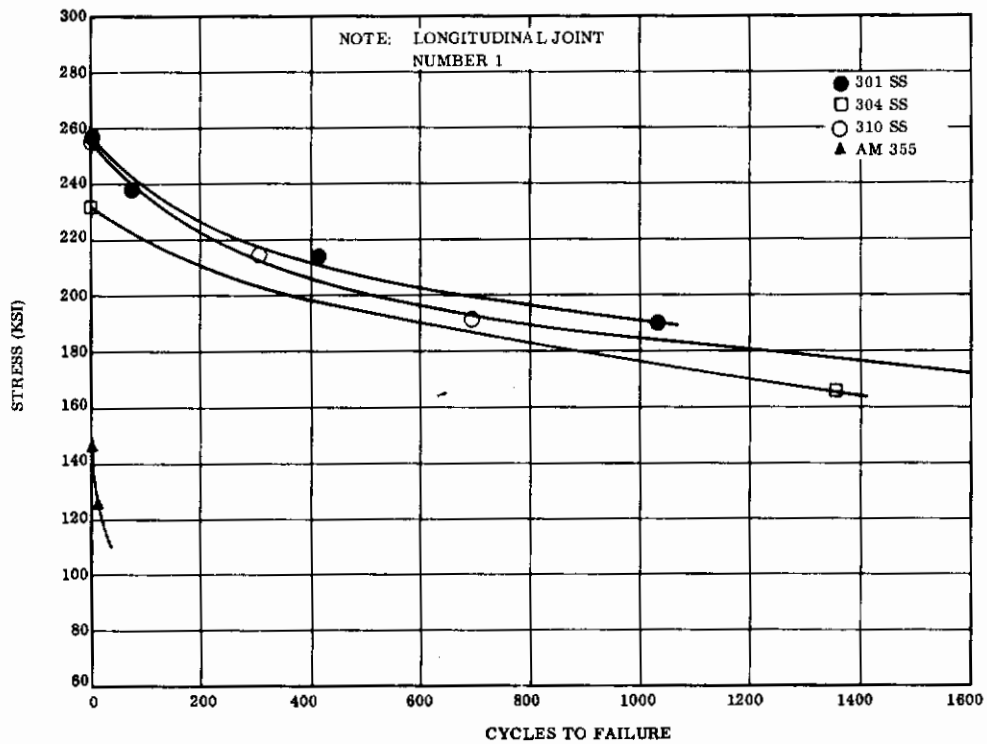

Figure 79. S-N Curve - Stainless Steels at -320°F (Longitudinal - Joint No. 1)

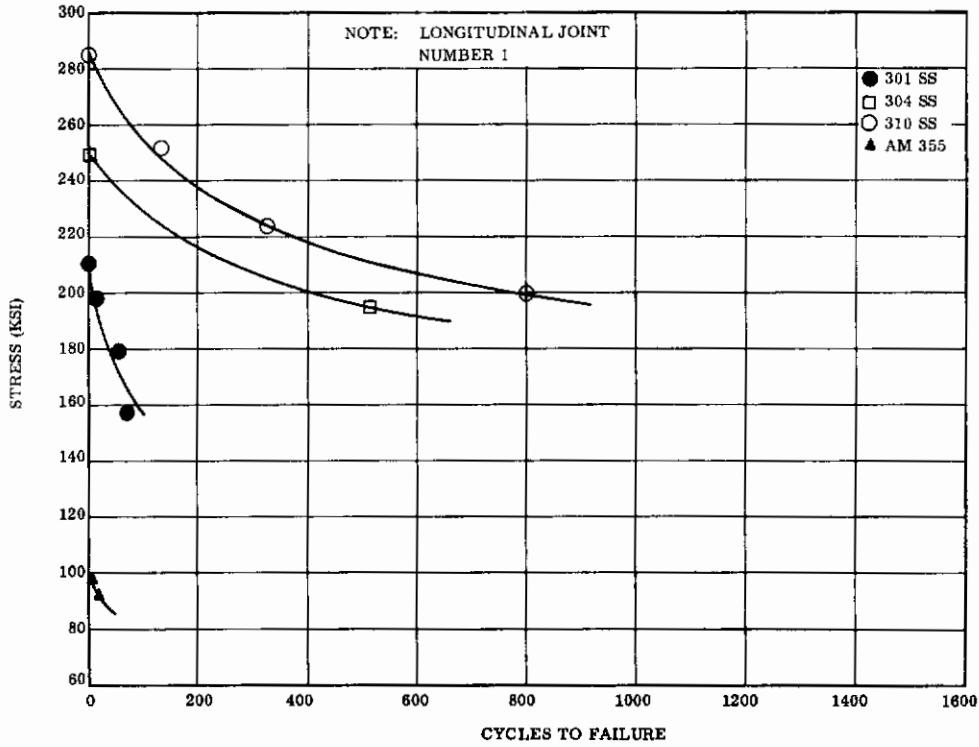

Figure 80. S-N Curve - Stainless Steels at -423°F (Longitudinal - Joint No. 1)

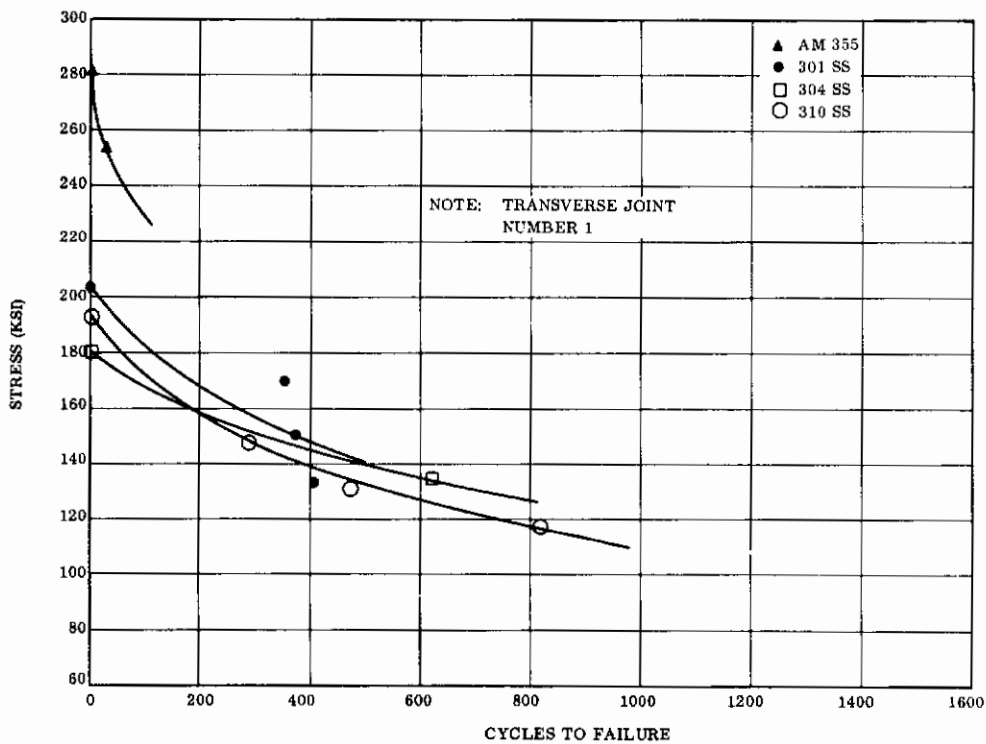

Figure 81. S-N Curve - Stainless Steels at 78°F (Transverse - Joint No. 1)

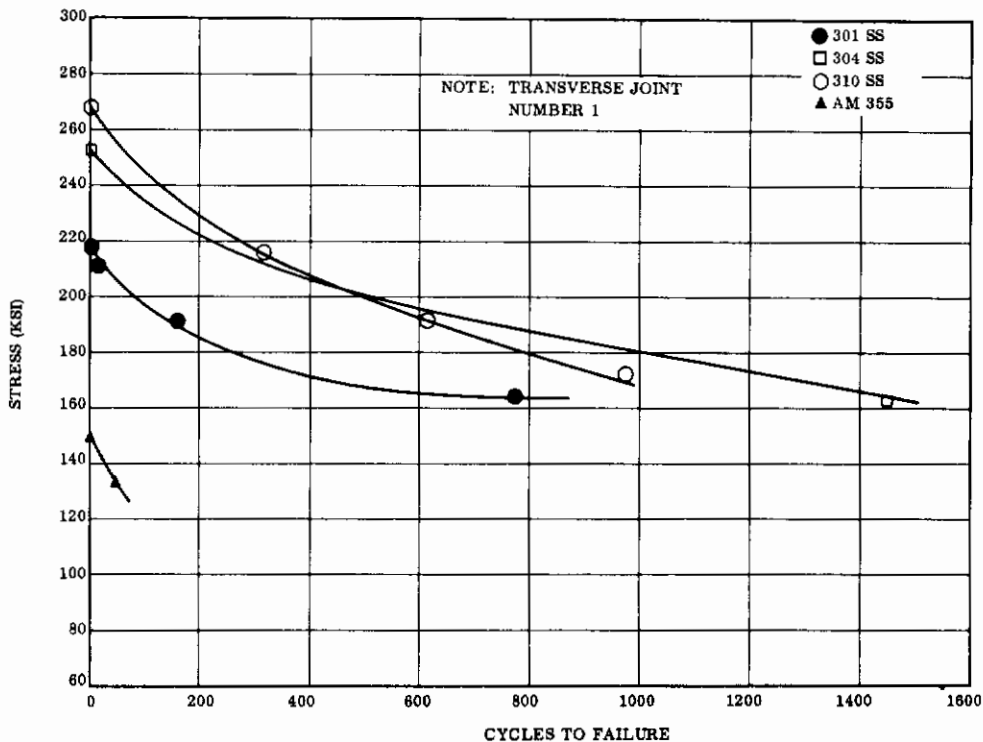

Figure 82. S-N Curve - Stainless Steels at -320°F (Transverse - Joint No. 1)

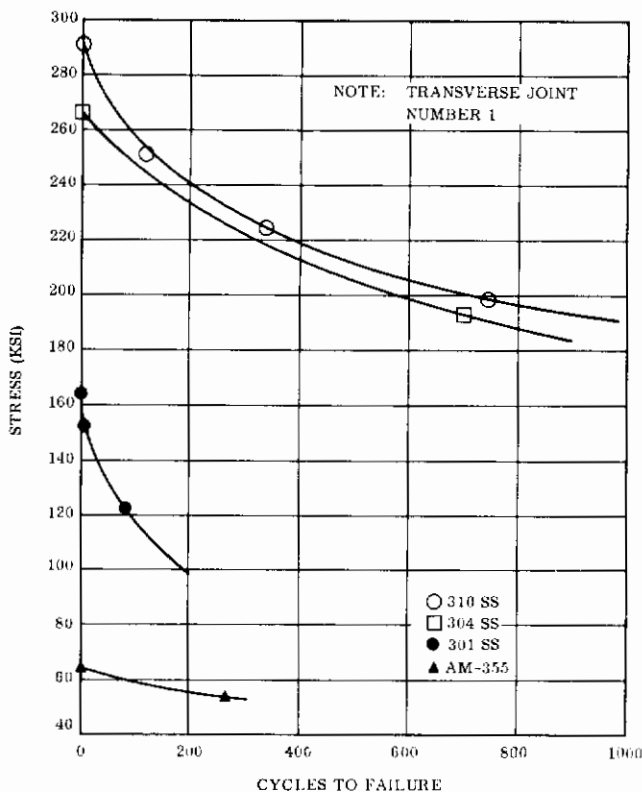

Figure 83. S-N Curve - Stainless Steels at -423°F (Transverse - Joint No. 1)

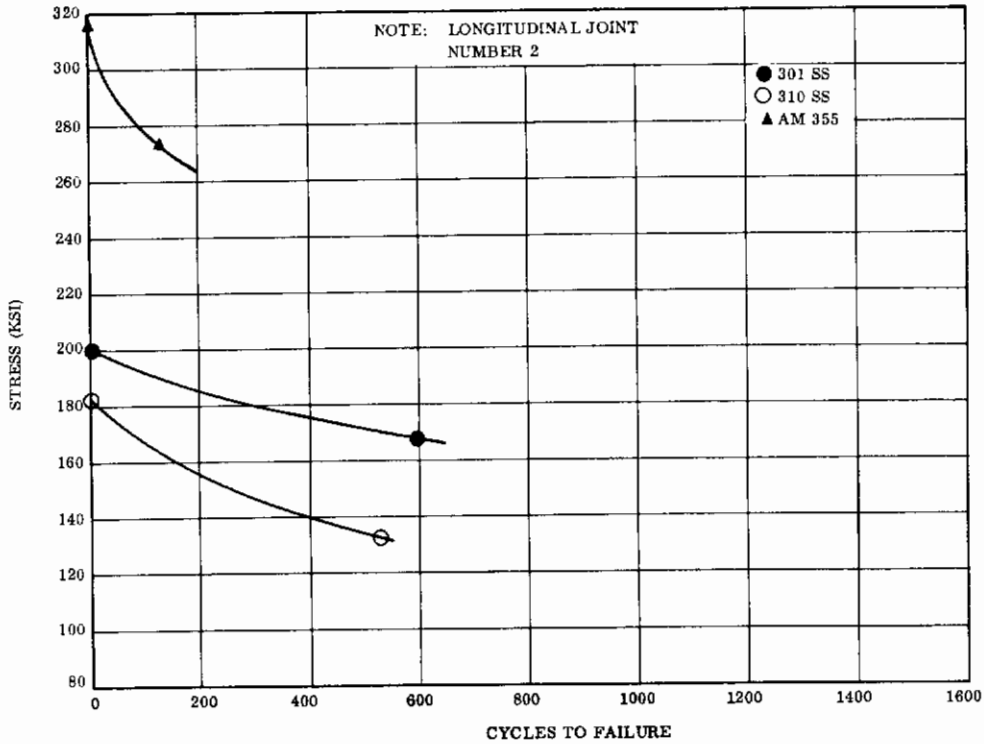

Figure 84. S-N Curve - Stainless Steels at 78°F (Longitudinal - Joint No. 2)

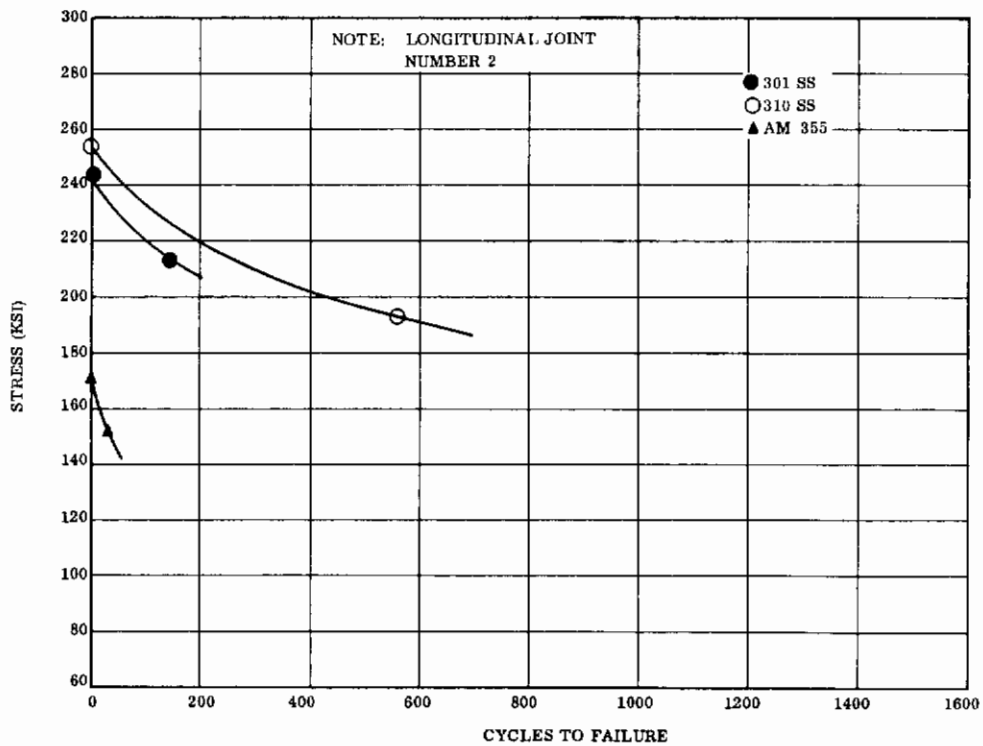

Figure 85. S-N Curve - Stainless Steels at -320°F (Longitudinal - Joint No. 2)

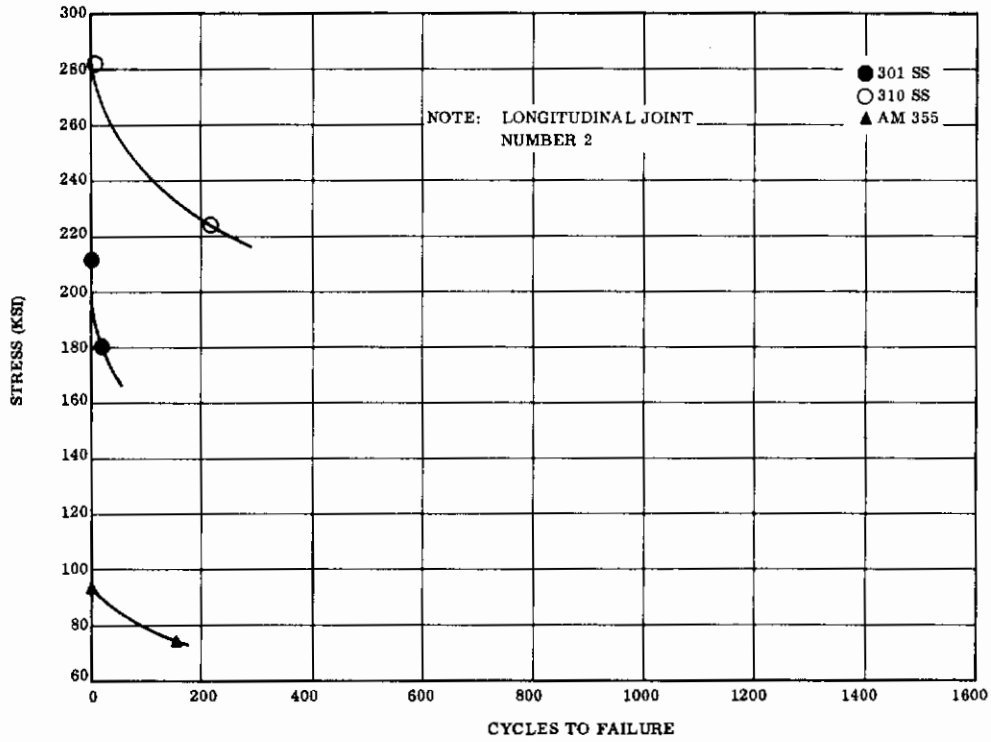

Figure 86. S-N Curve - Stainless Steels at -423°F (Longitudinal - Joint No. 2)

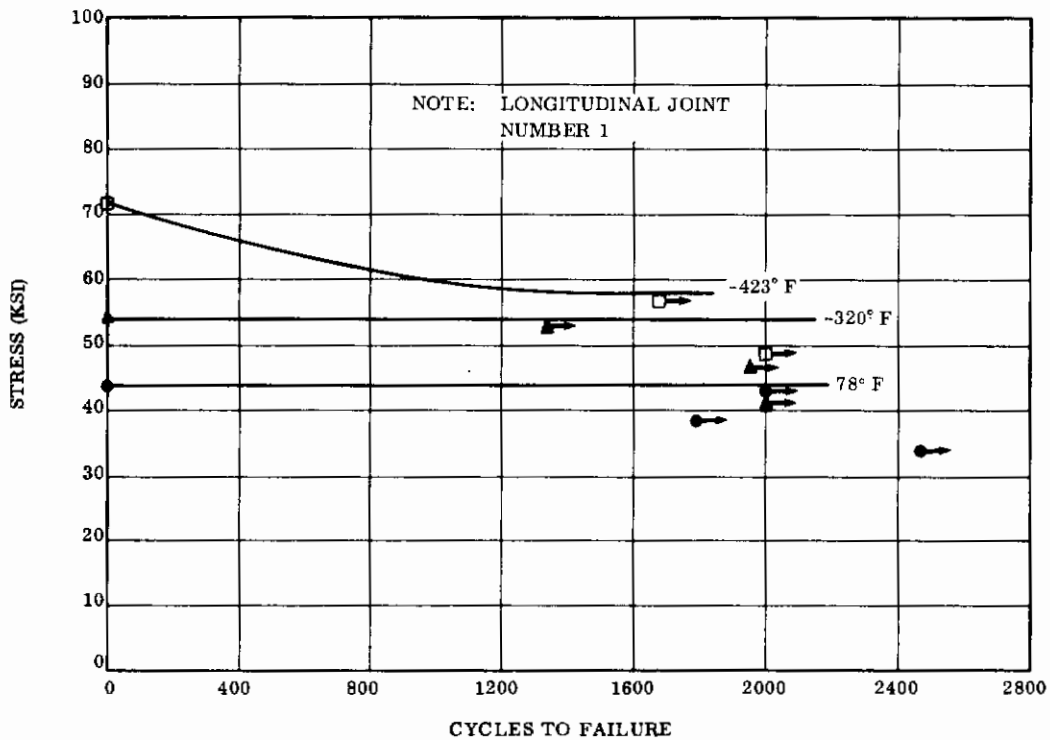

Figure 87. S-N Curve - 2014-T6 Aluminum Alloy (Longitudinal - Joint No. 1)

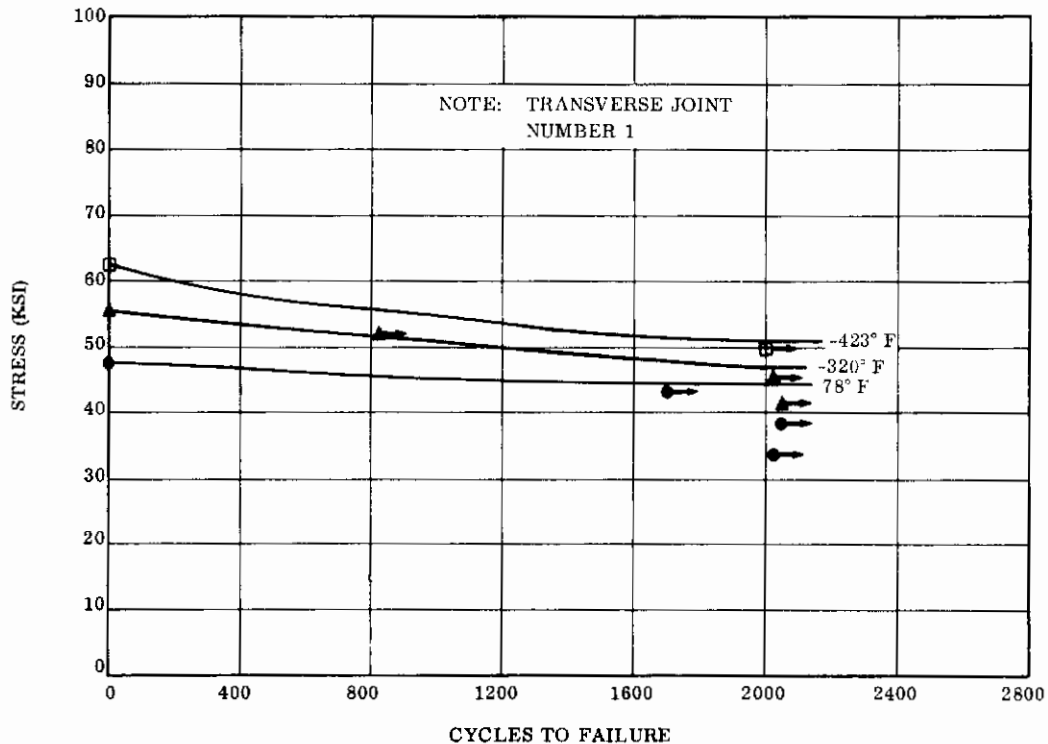

Figure 88. S-N Curve - 2014-T6 Aluminum Alloy (Transverse - Joint No. 1)

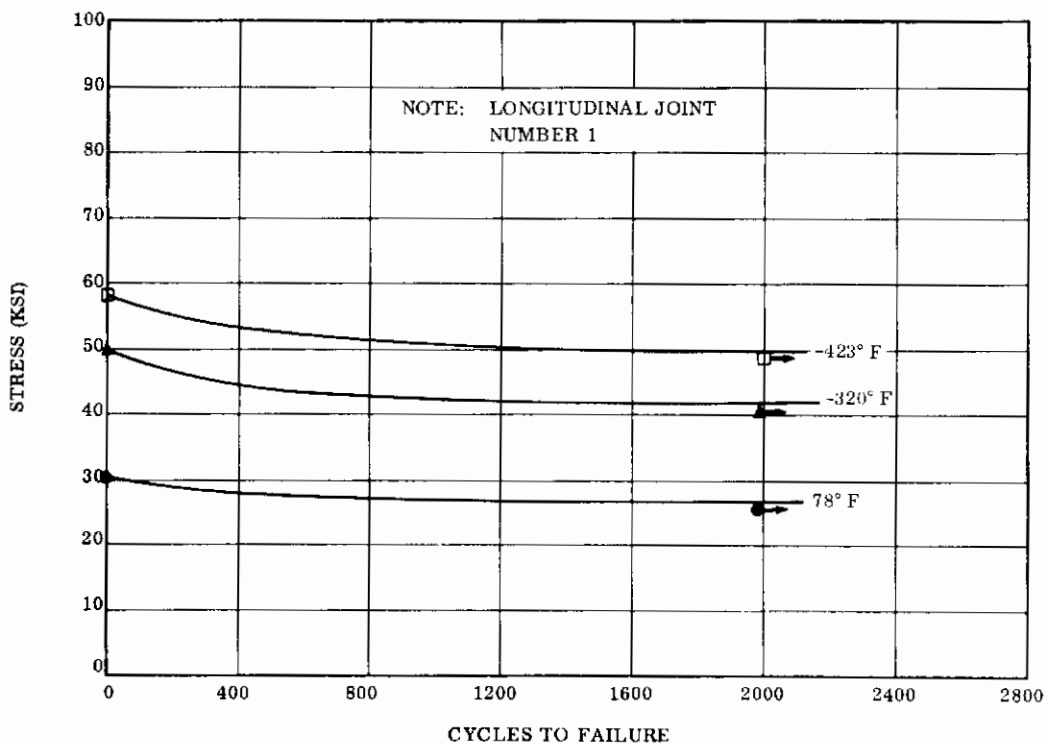

Figure 89. S-N Curve - 5052-H38 Aluminum Alloy (Longitudinal - Joint No. 1)

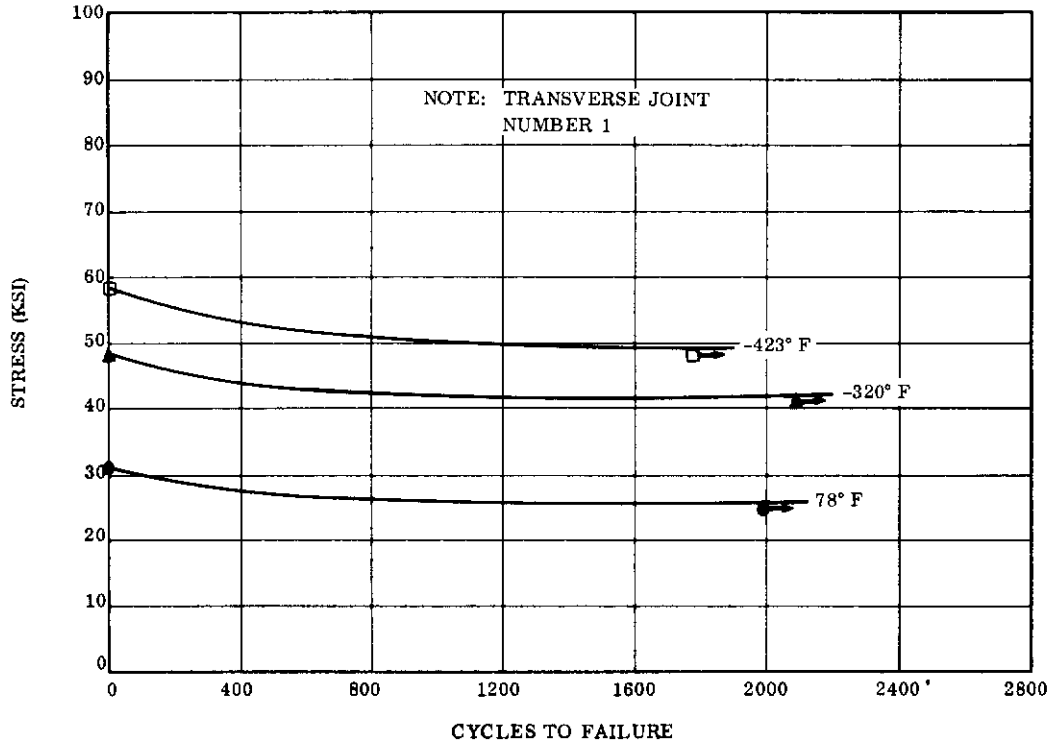

Figure 90. S-N Curve - 5052-H38 Aluminum Alloy (Transverse - Joint No. 1)

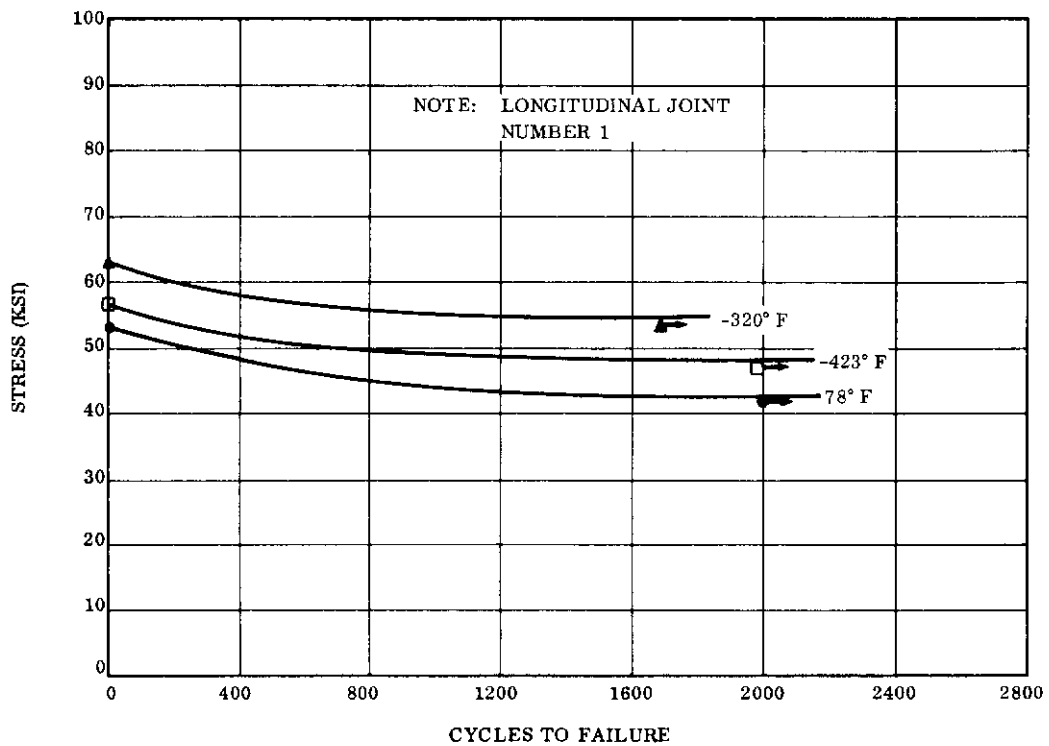

Figure 91. S-N Curve - 5456-H343 Aluminum Alloy (Longitudinal - Joint No. 1)

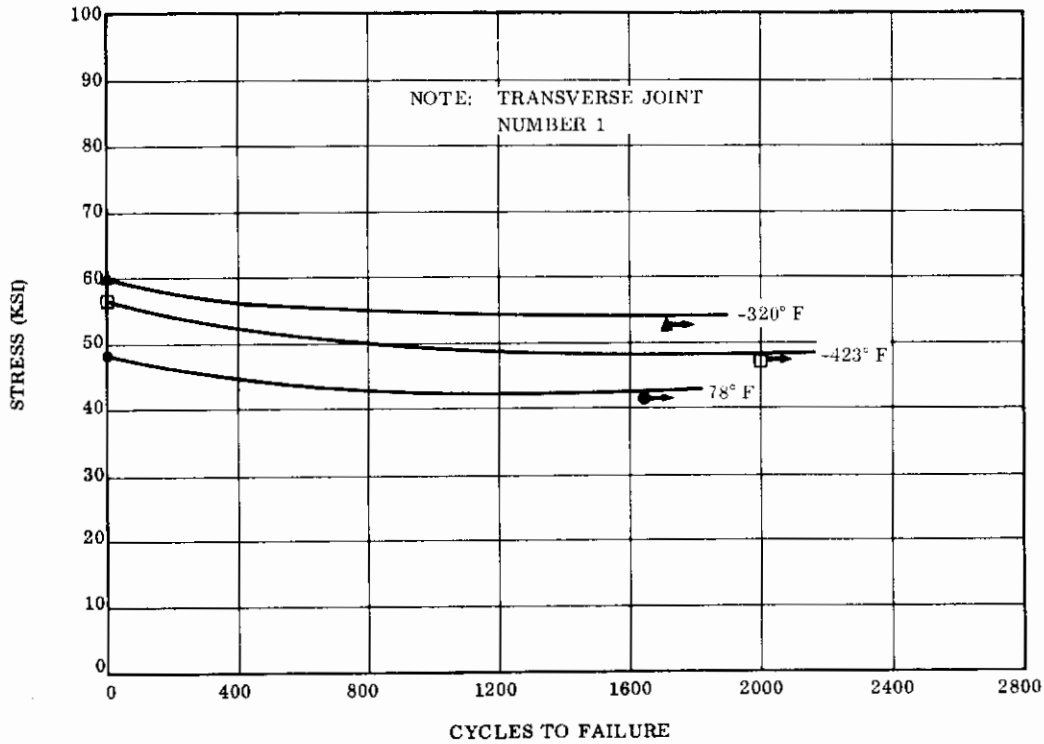

Figure 92. S-N Curve - 5456-H343 Aluminum Alloy (Transverse - Joint No. 1)

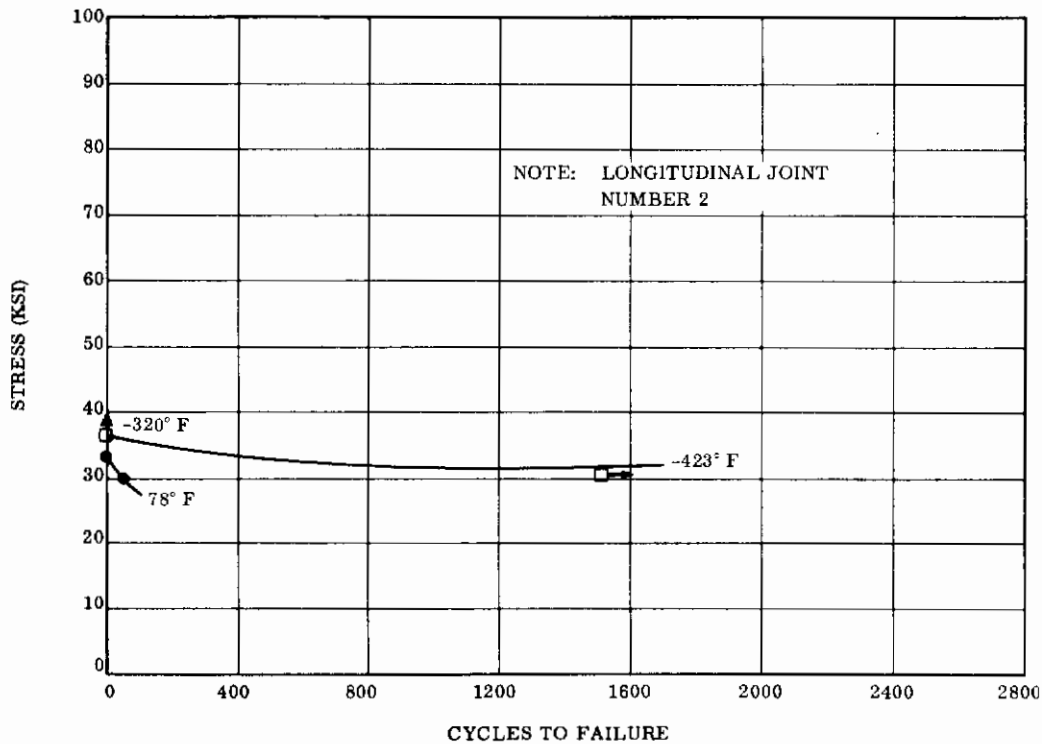

Figure 93. S-N Curve - 5456-H343 Aluminum Alloy (Longitudinal - Joint No. 2)

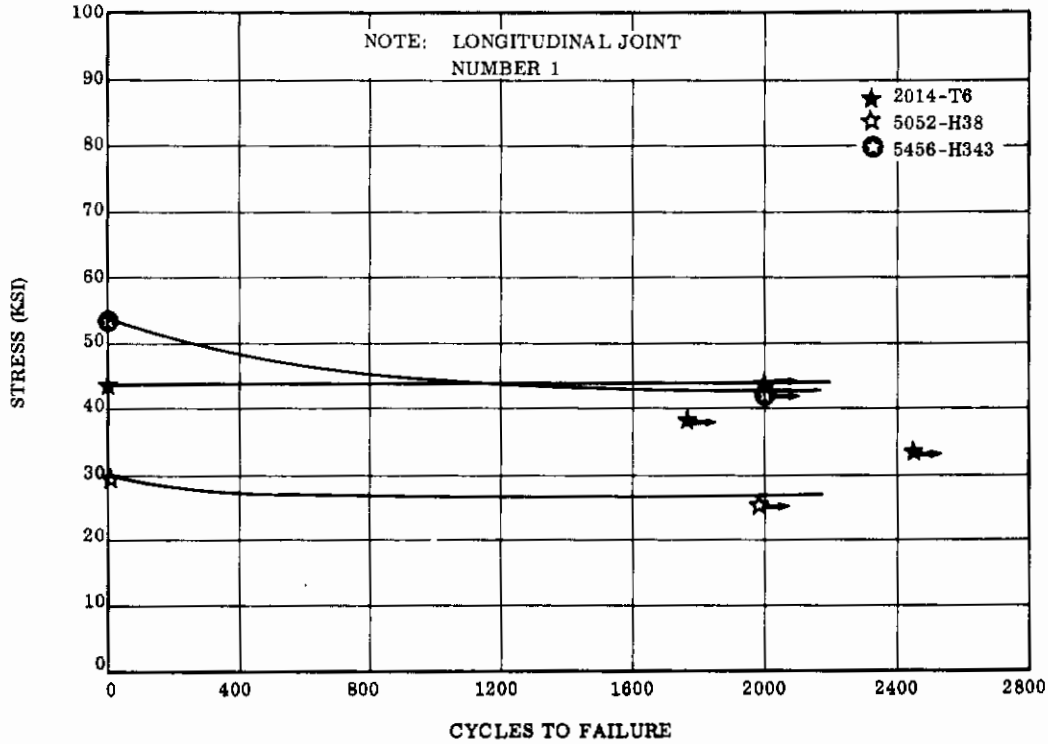

Figure 94. S-N Curve - Aluminum Alloys at 78°F (Longitudinal - Joint No. 1)

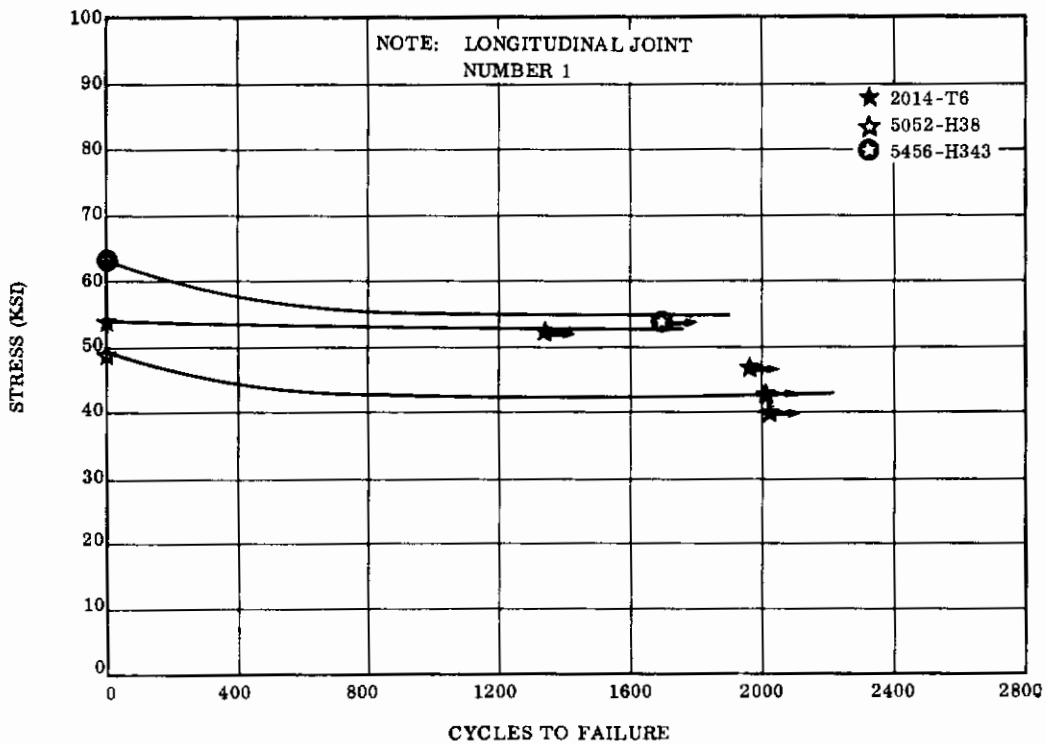

Figure 95. S-N Curve - Aluminum Alloys at -320°F (Longitudinal - Joint No. 1)

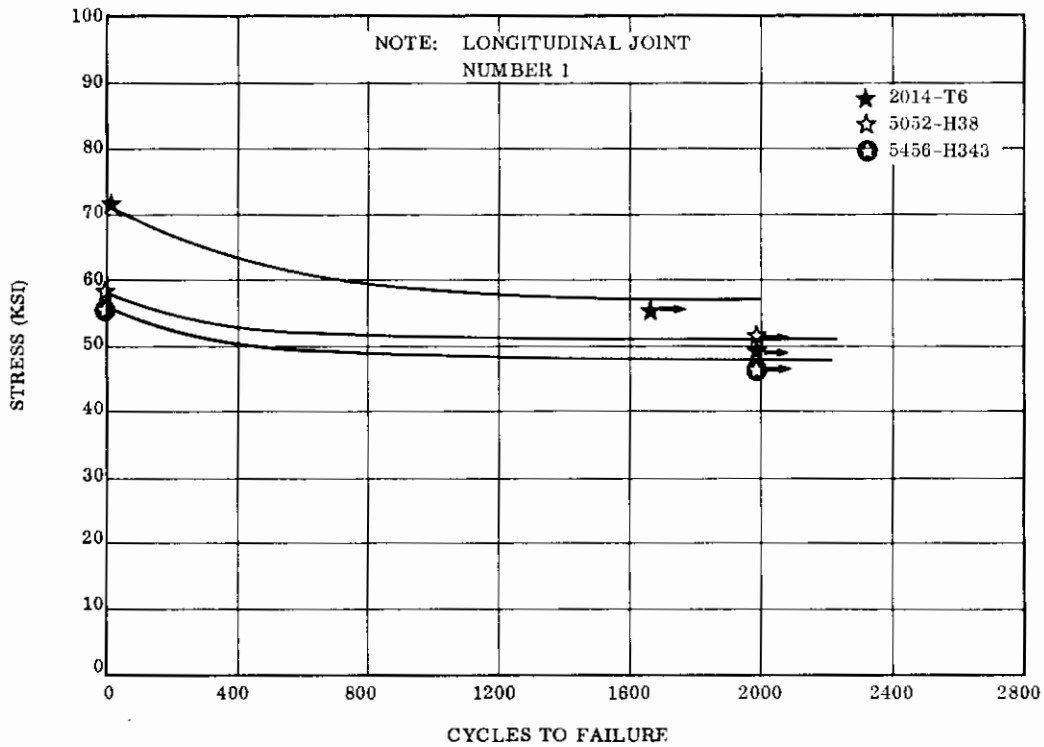

Figure 96. S-N Curve - Aluminum Alloys at -423°F (Longitudinal - Joint No. 1)

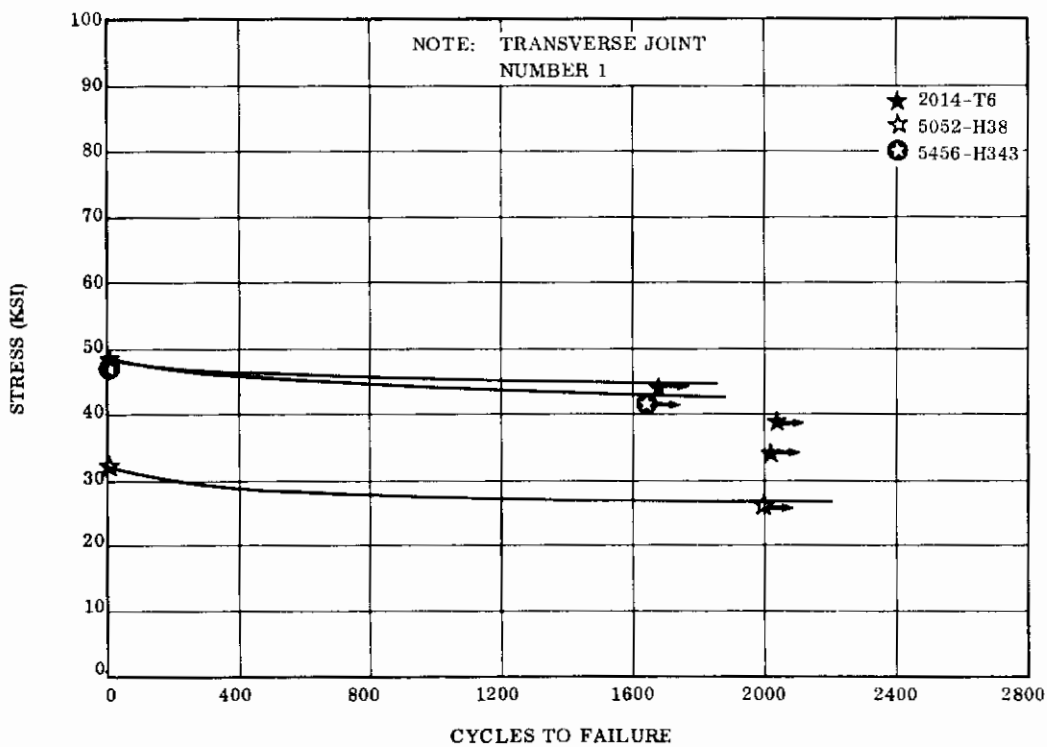

Figure 97. S-N Curve - Aluminum Alloys at 78°F (Transverse - Joint No. 1)

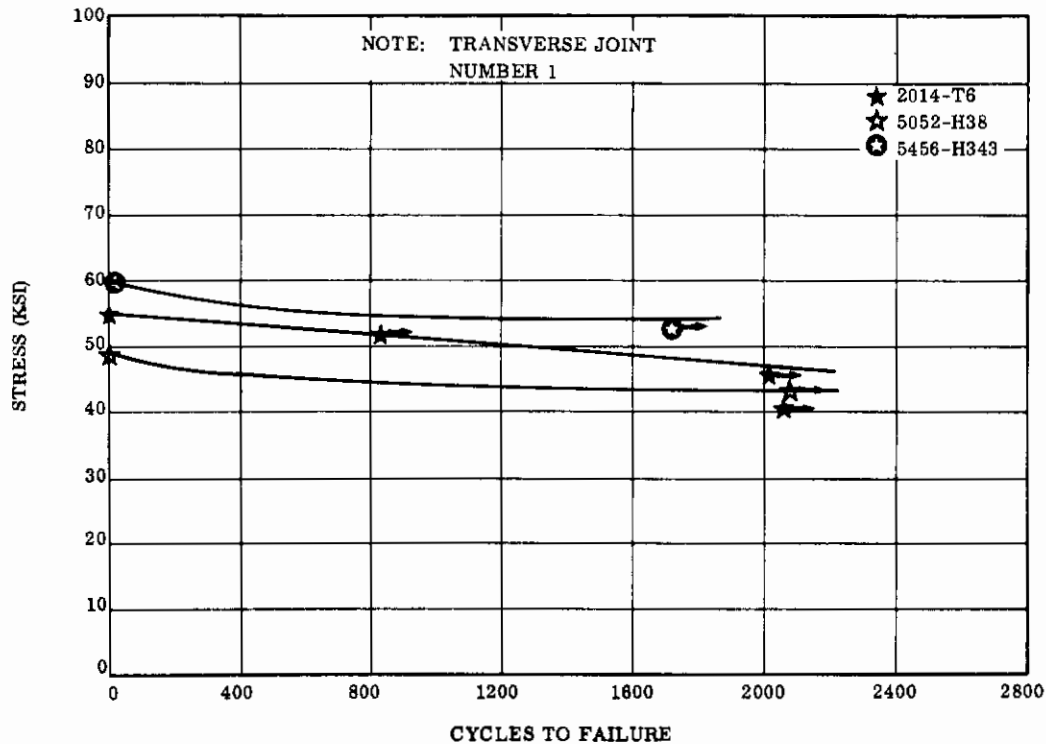

Figure 98. S-N Curve - Aluminum Alloys at -320°F (Transverse - Joint No. 1)

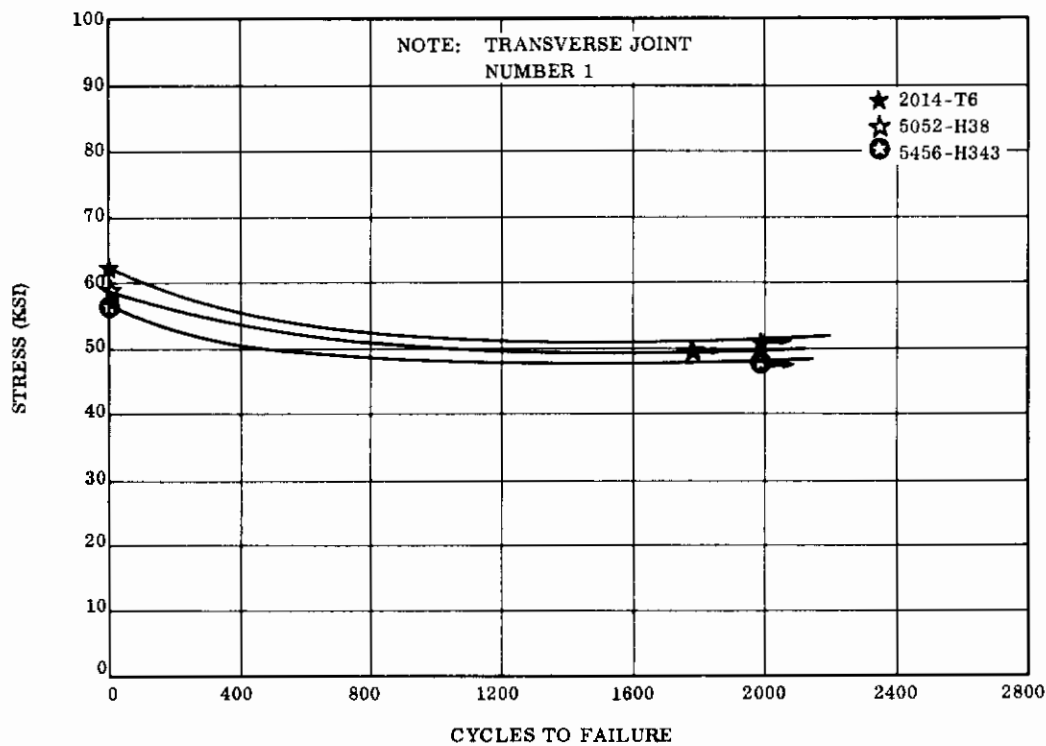

Figure 99. S-N Curve - Aluminum Alloys at -423°F (Transverse - Joint No. 1)

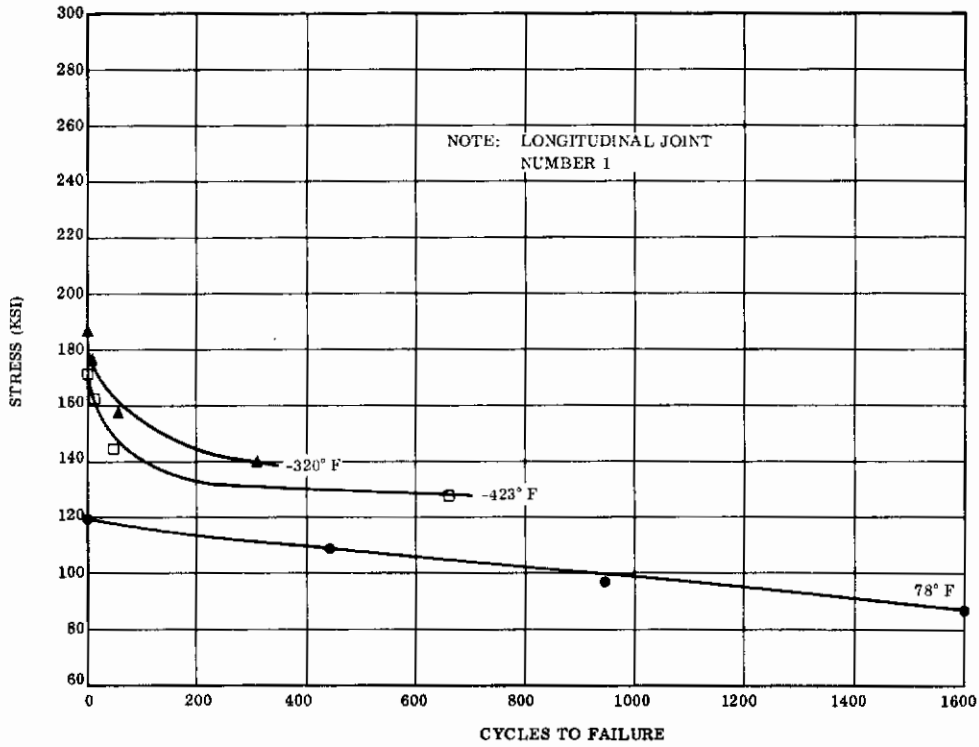

Figure 100. S-N Curve - Ti-5Al-2.5Sn Alloy (Longitudinal - Joint No. 1)

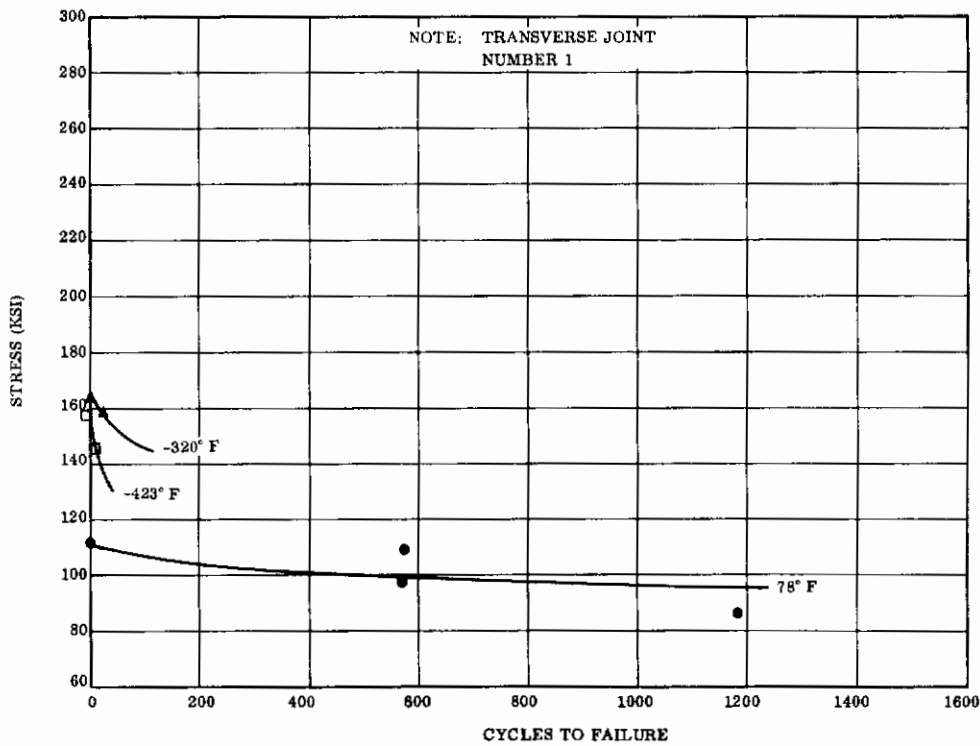

Figure 101. S-N Curve - Ti-5Al-2.5Sn Alloy (Transverse - Joint No. 1)

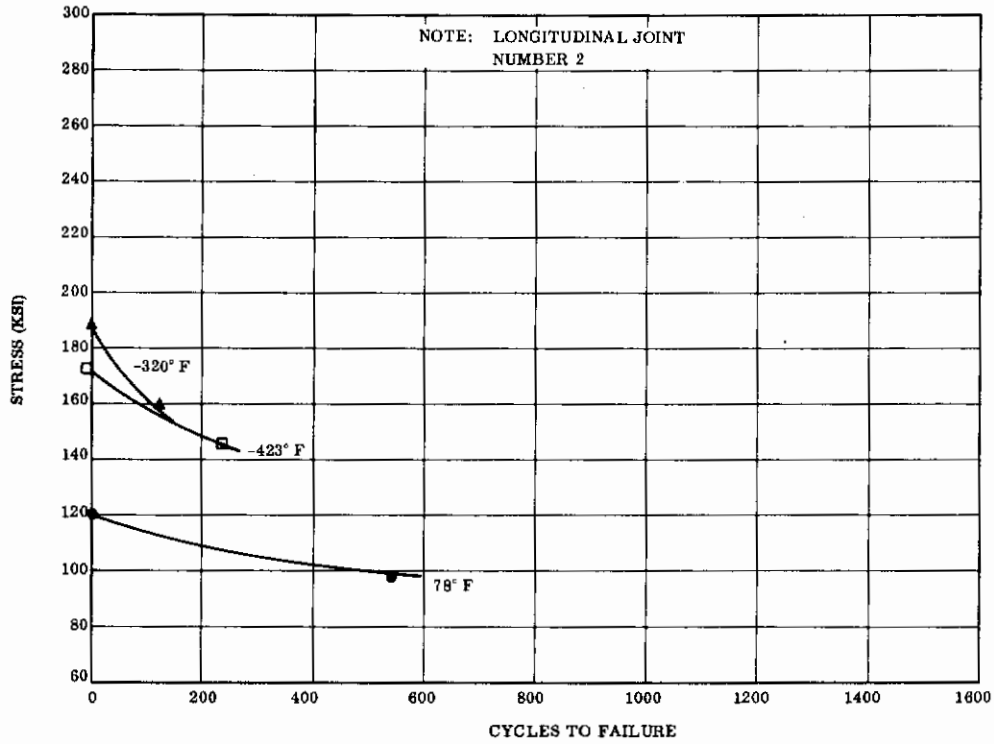

Figure 102. S-N Curve - Ti-5Al-2.5Sn Alloy (Longitudinal - Joint No. 2)

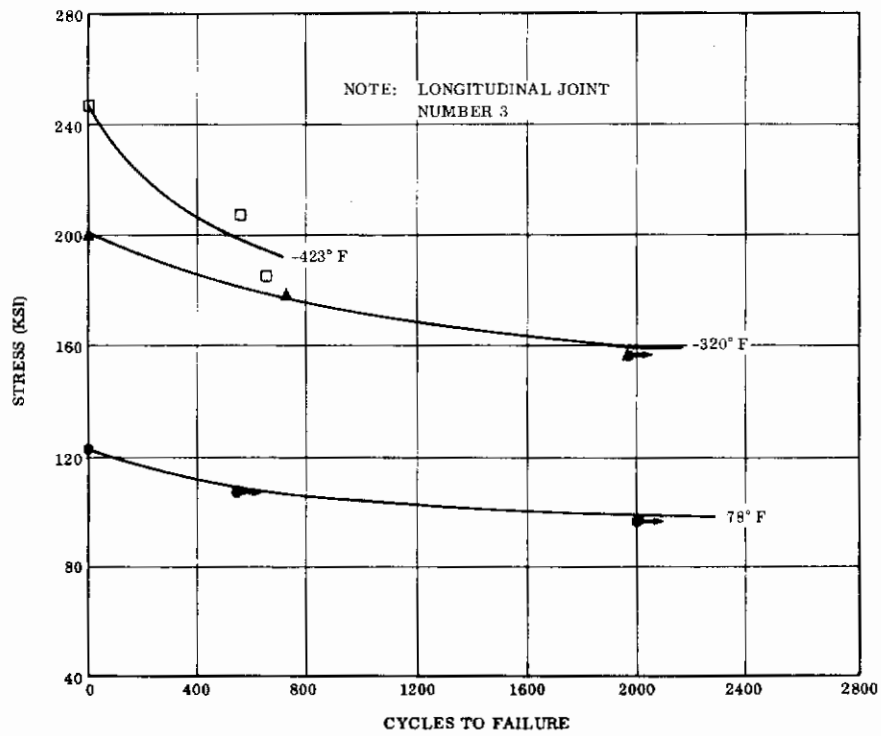
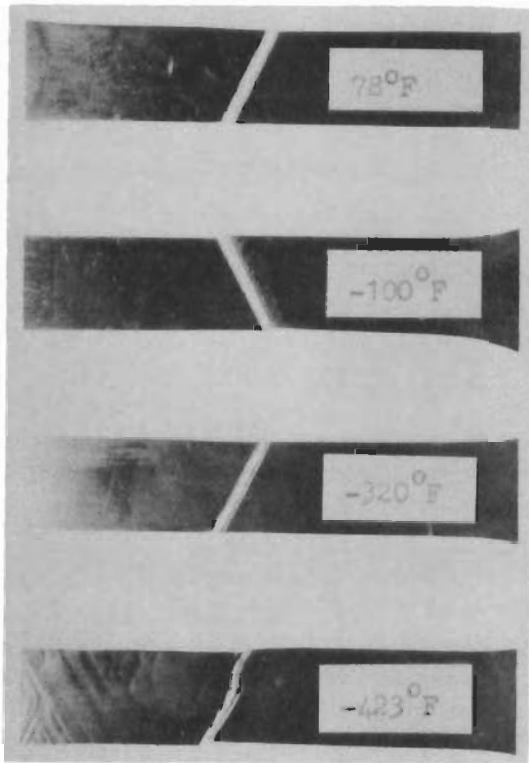
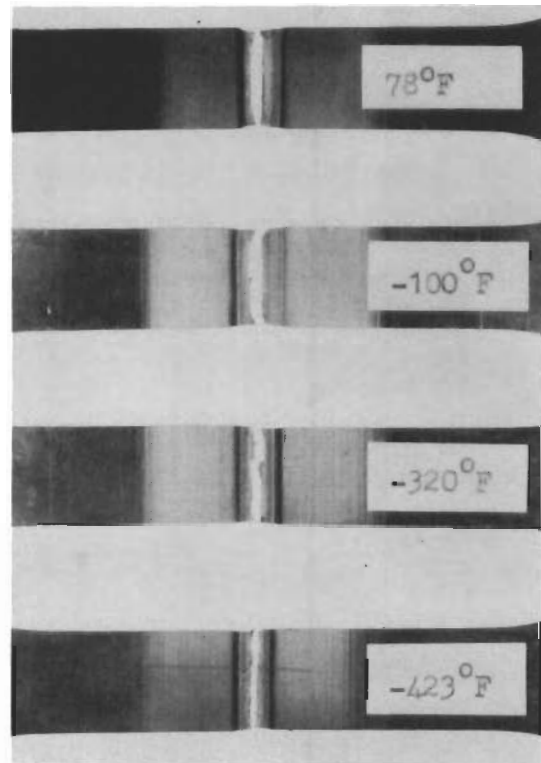

Figure 103. S-N Curve - Ti-5Al-2.5Sn Alloy (Longitudinal - Joint No. 3)



301 Stainless Steel



301 Stainless Steel Welds

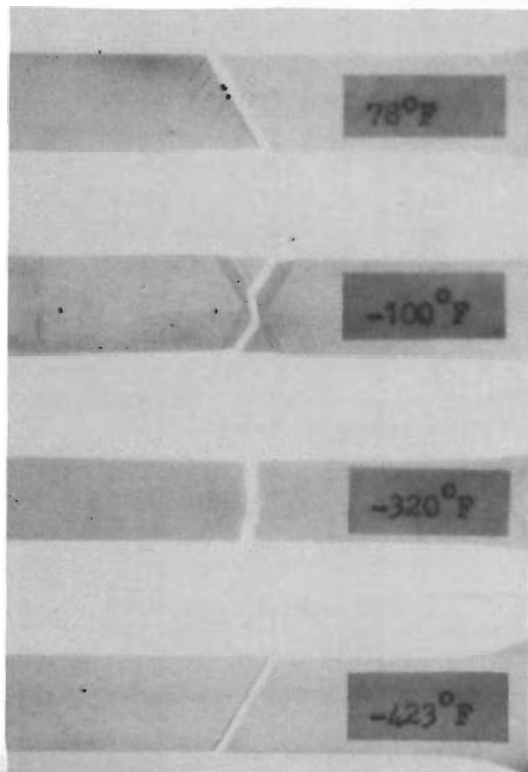

304 Stainless Steel

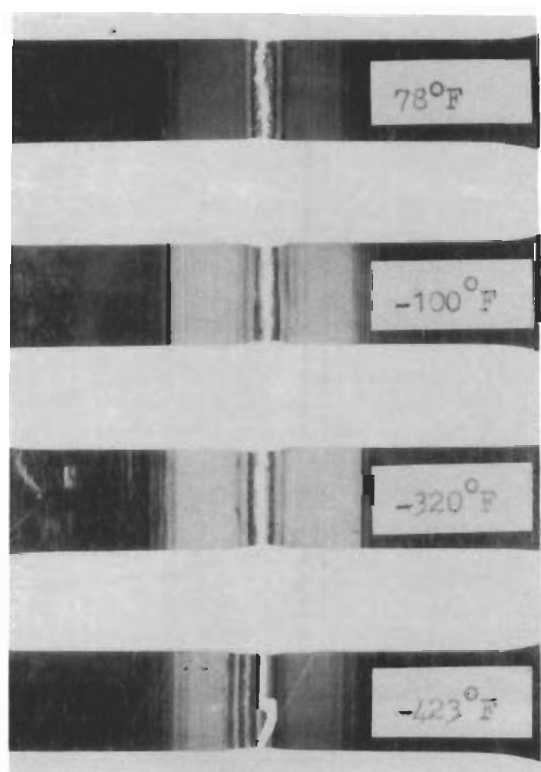

304 Stainless Steel Welds

Figure 104. Photomicrographs of Fractured Tensile Specimens (301 and 304 Stainless Steels)

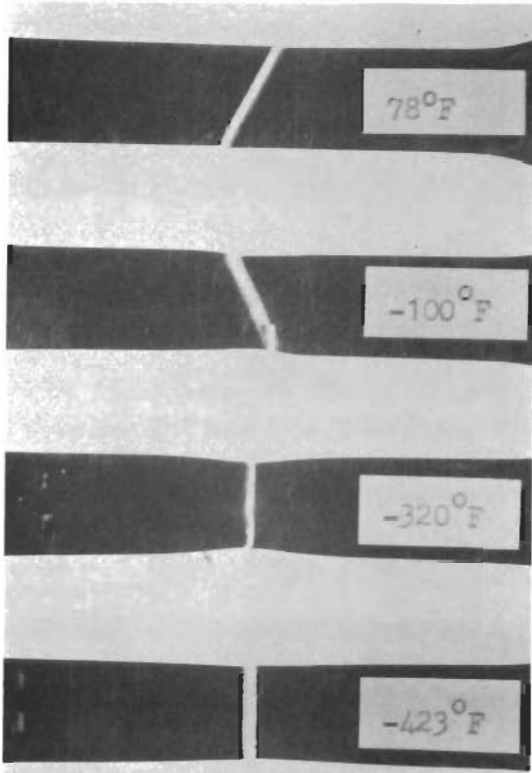

310 Stainless Steel

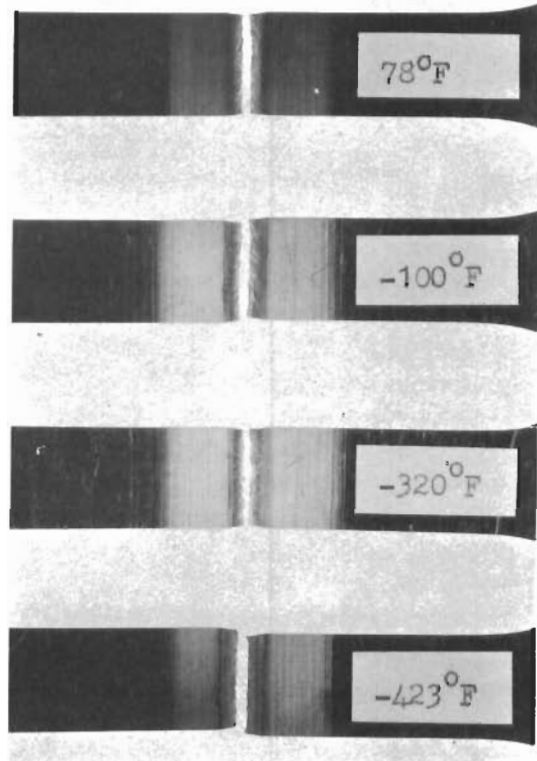

310 Stainless Steel Welds

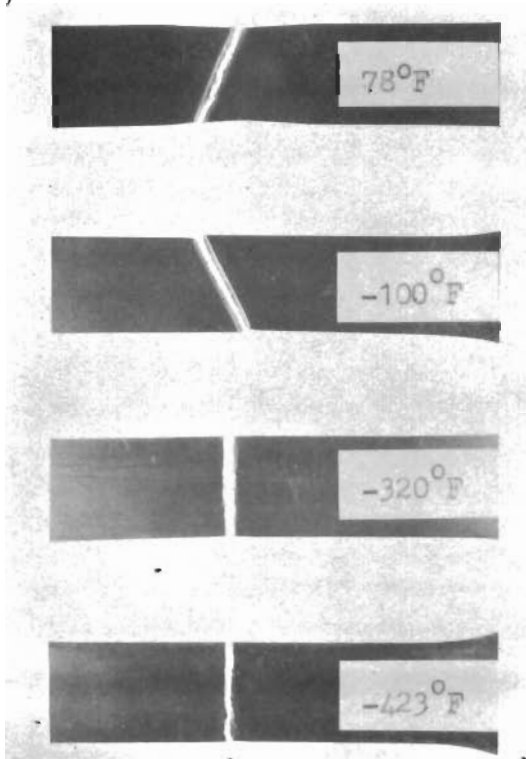

AM-355 Stainless Steel

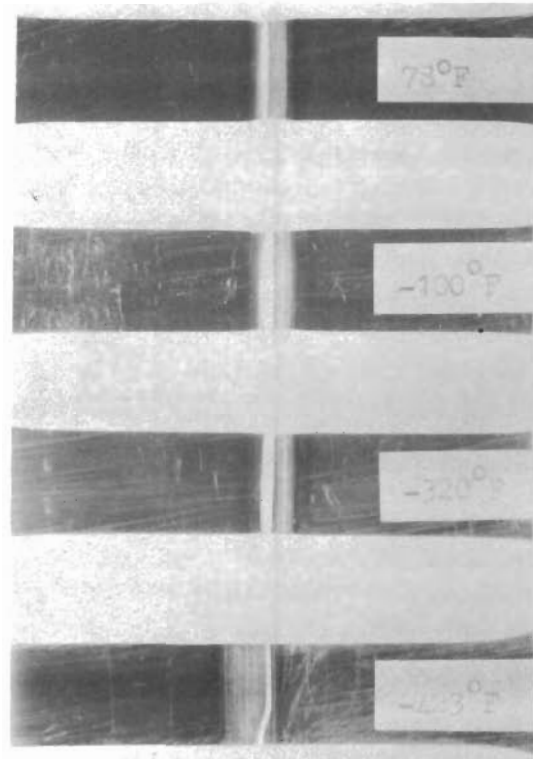

AM-355 Stainless Steel Welds

Figure 105. Photomicrographs of Fractured Tensile Specimens (310 and AM-355 Stainless Steels)

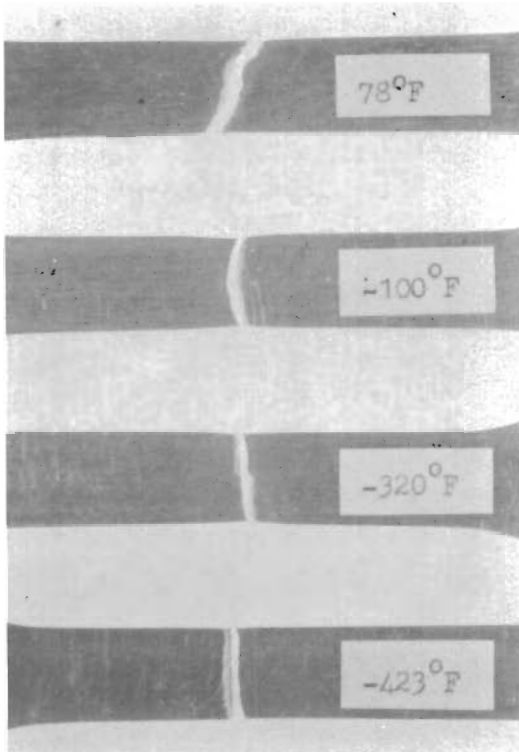

2014-T6 Aluminum Alloy

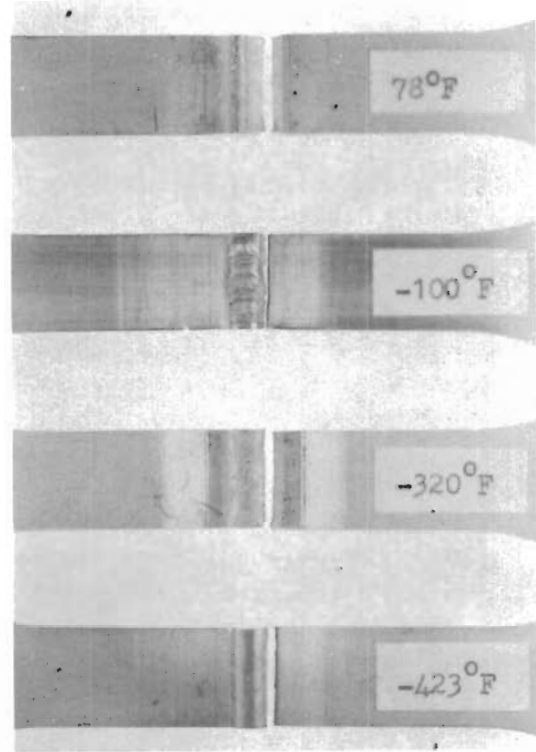

2014-T6 Aluminum Alloy Welds

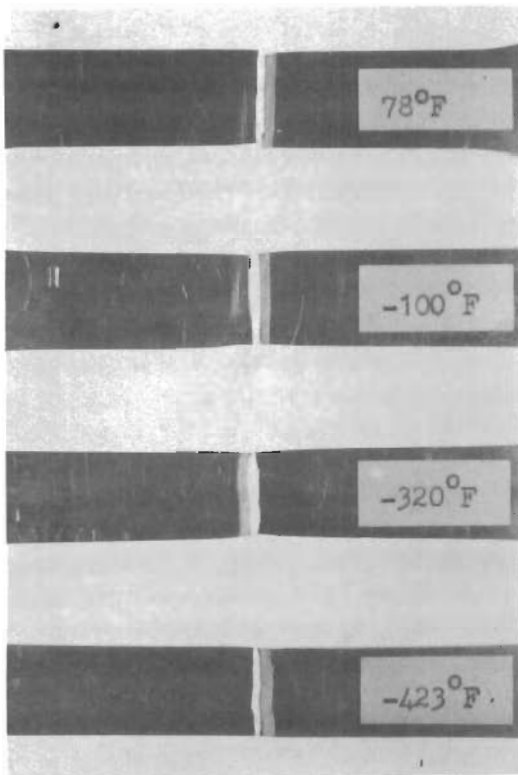

5052-H38 Aluminum Alloy

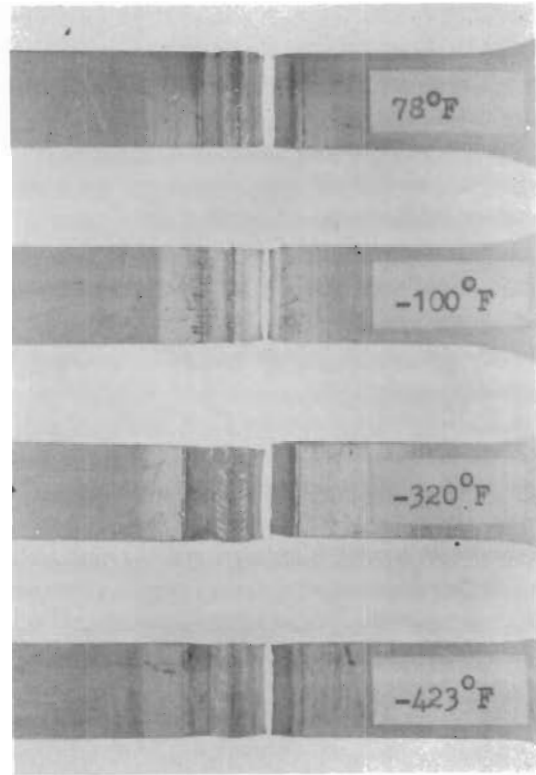

5052-H38 Aluminum Alloy Welds

Figure 106. Photomicrographs of Fractured Tensile Specimens (2014-T6 and 5052-H38 Aluminum)

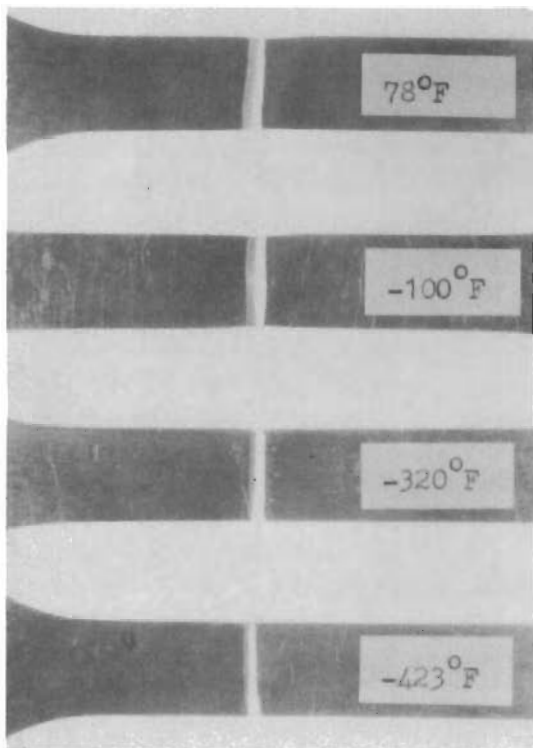

5456-H343 Aluminum Alloy

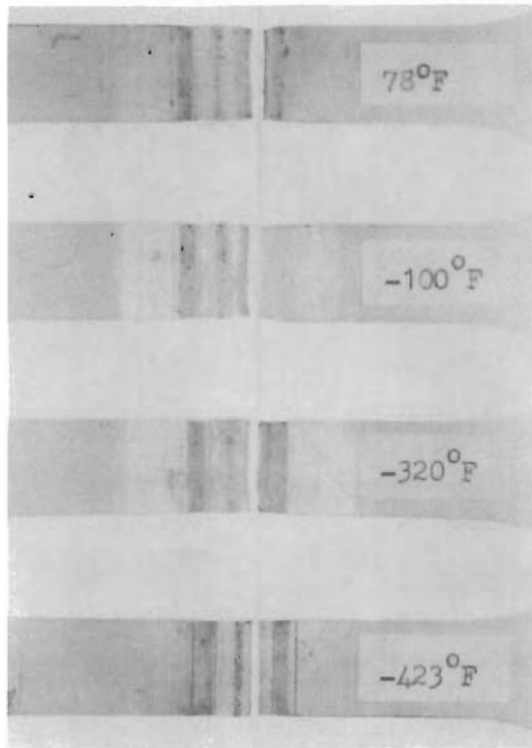

5456-H343 Aluminum Alloy Welds

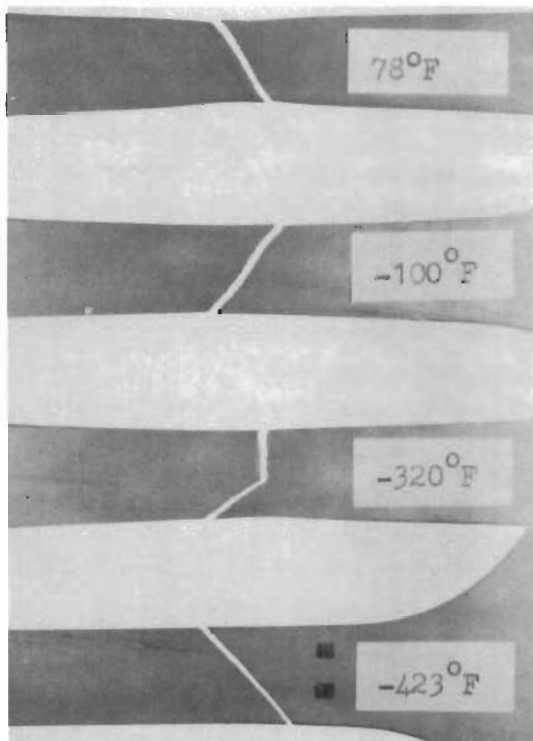

Ti-5Al-2.5Sn Alloy

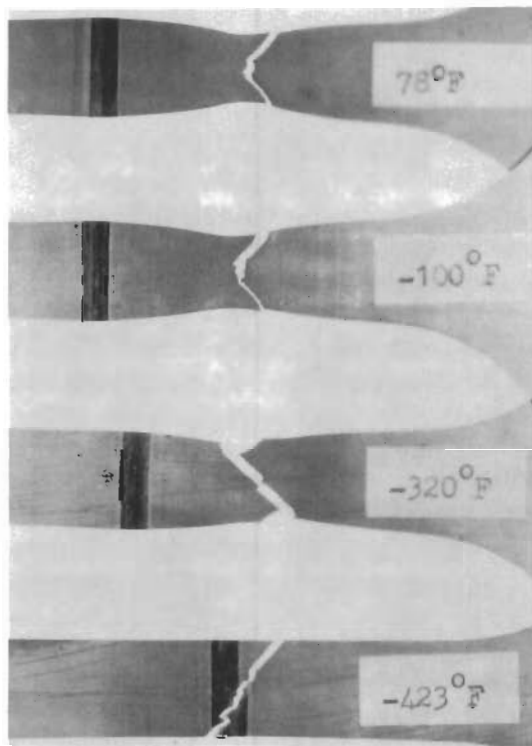

Ti-5Al-2.5Sn Alloy Welds

Figure 107. Photomicrographs of Fractured Tensile Specimens (5456-H343 Al and Ti-5Al-2.5Sn)

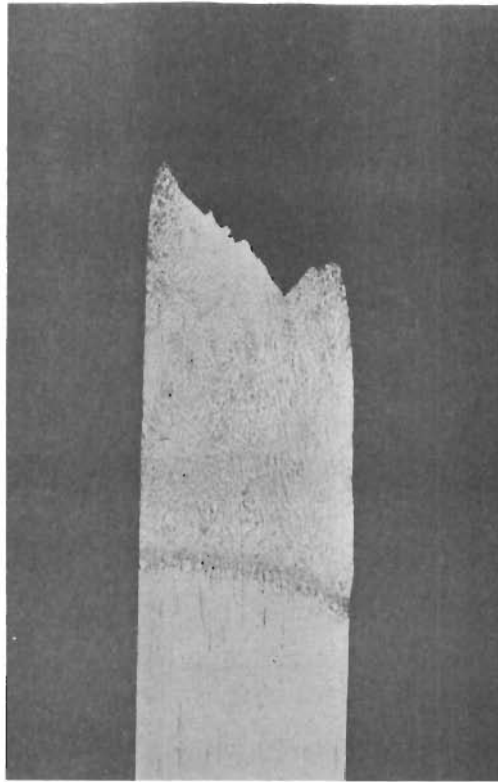

Weld
50X
-423° F
Oxalic Electrolytic Etchant

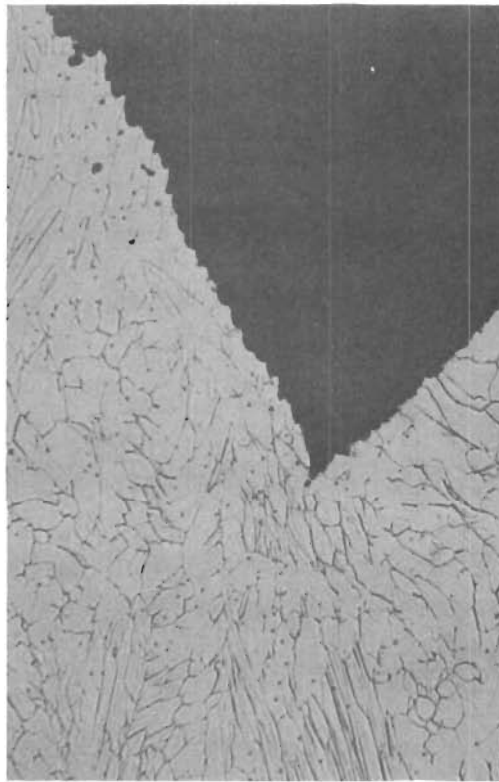

Weld
500X
-423° F
Oxalic Electrolytic Etchant

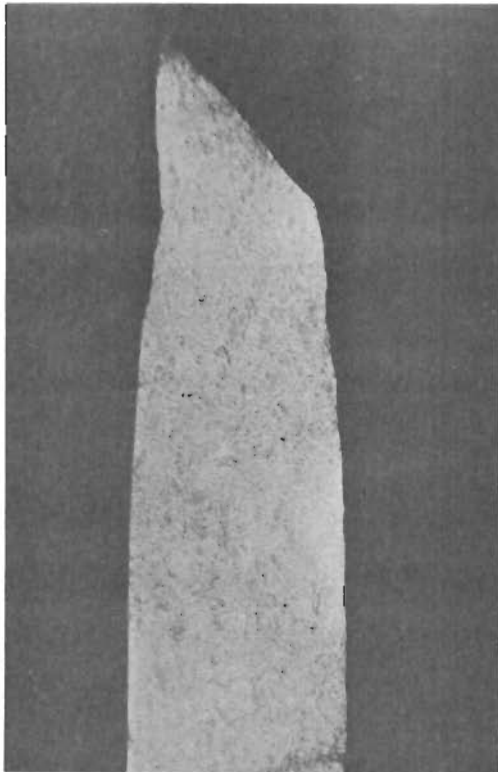

Weld
50X
78° F
Oxalic Electrolytic Etchant

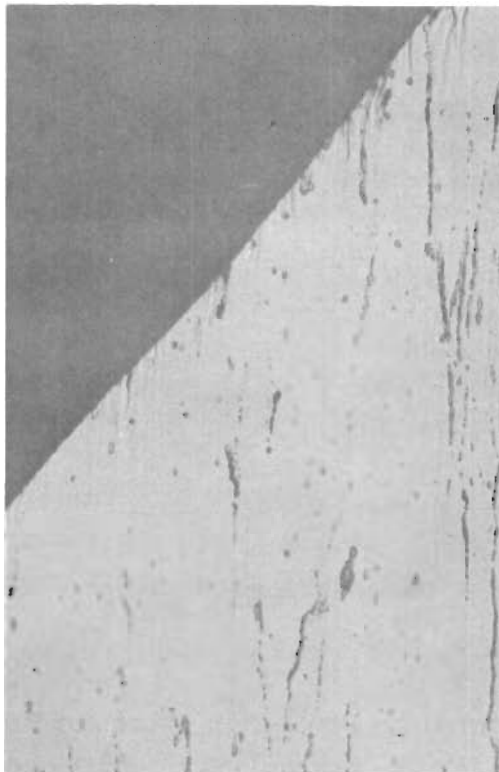

Base Metal
500X
-423° F
Oxalic Electrolytic Etchant

Figure 108. Photomicrographs of Fractured Tensile Specimens (301 SS)

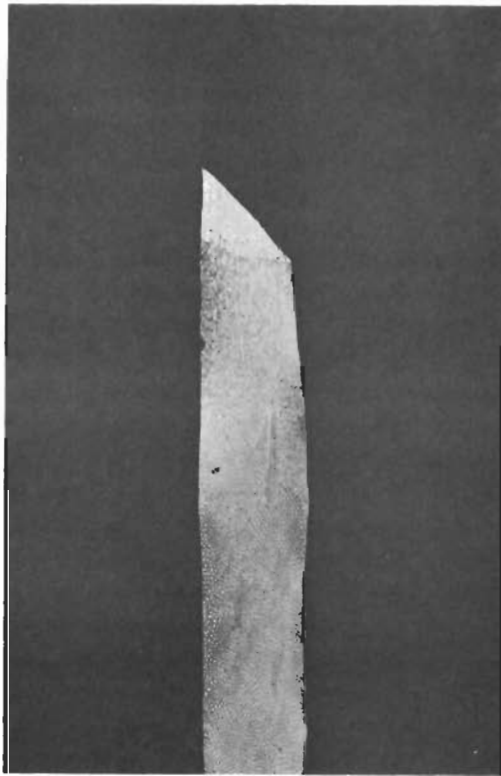

Weld
50X
-423° F
Oxalic Electrolytic Etchant

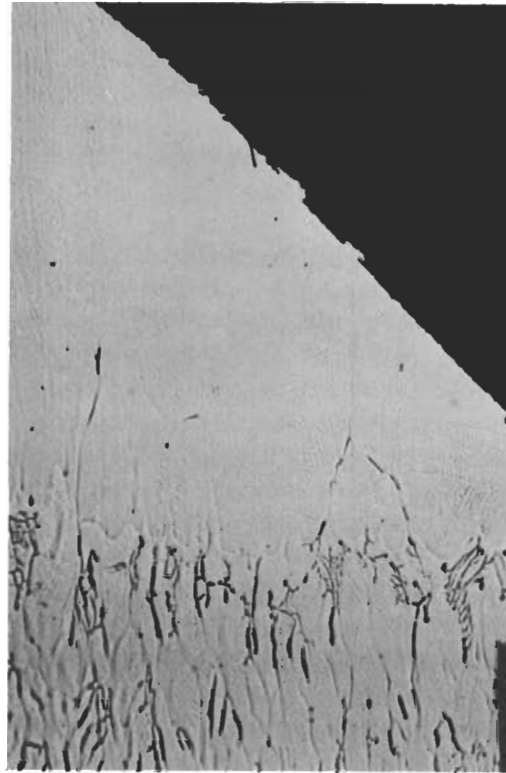

Weld
500X
-423° F
Oxalic Electrolytic Etchant

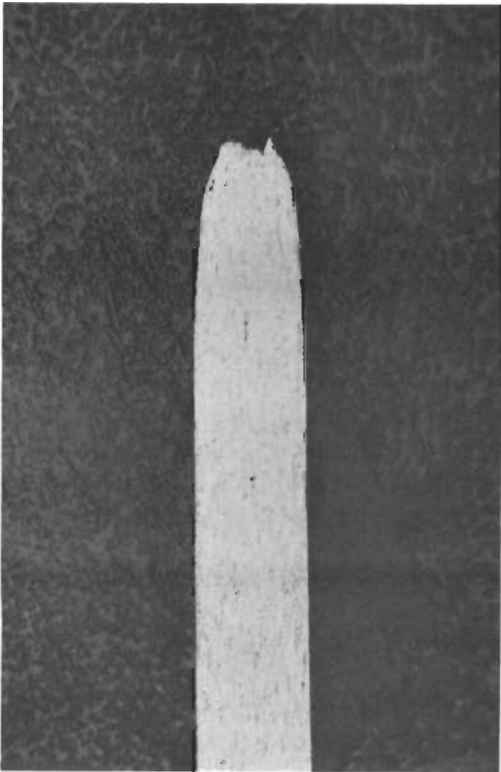

Base Metal
50X
-423° F
Oxalic Electrolytic Etchant

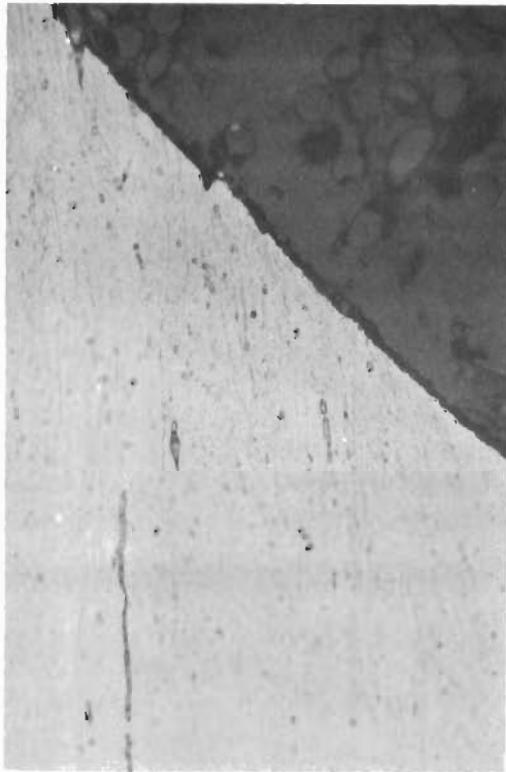

Base Metal
500X
-100° F
Oxalic Electrolytic Etchant

Figure 109. Photomicrographs of Fractured Tensile Specimens (304 SS)

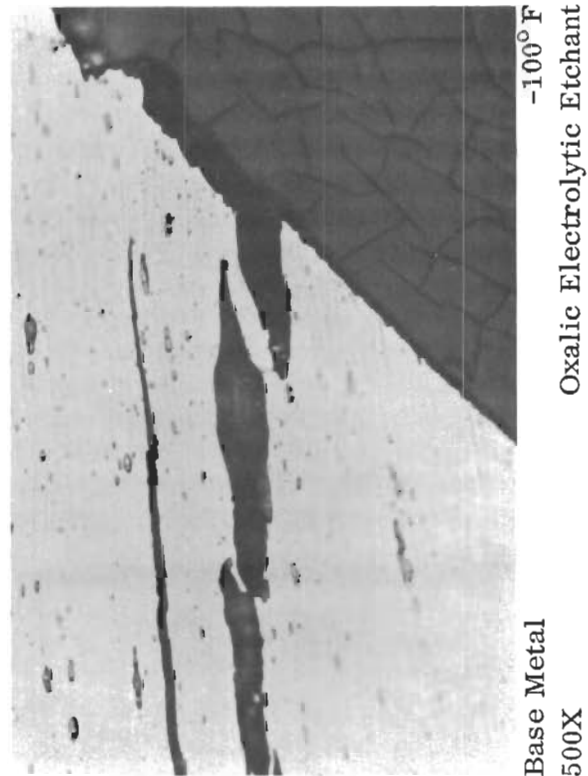
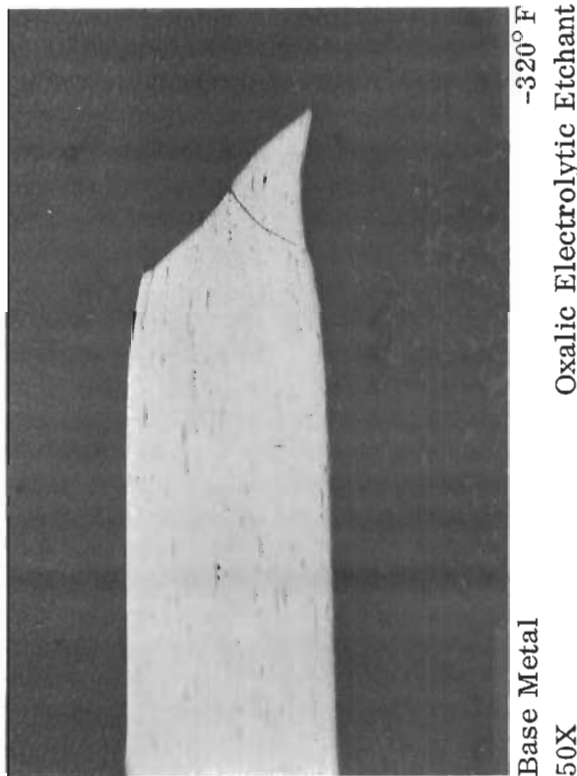
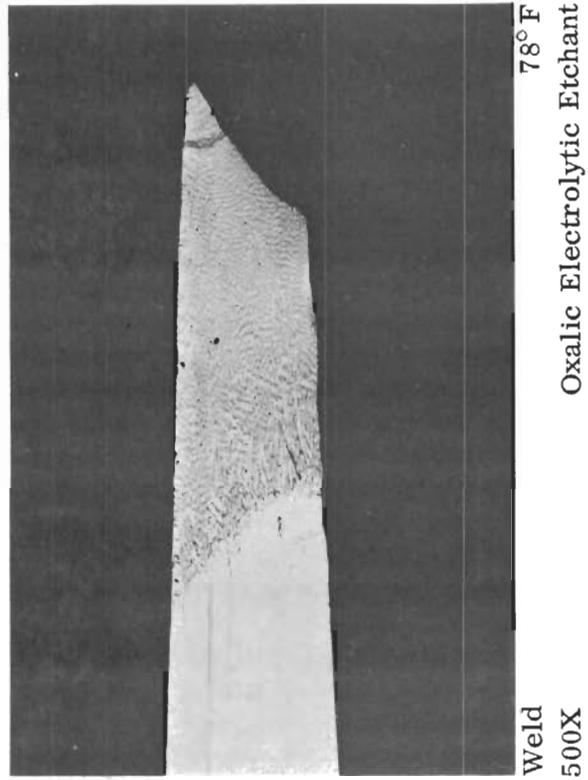
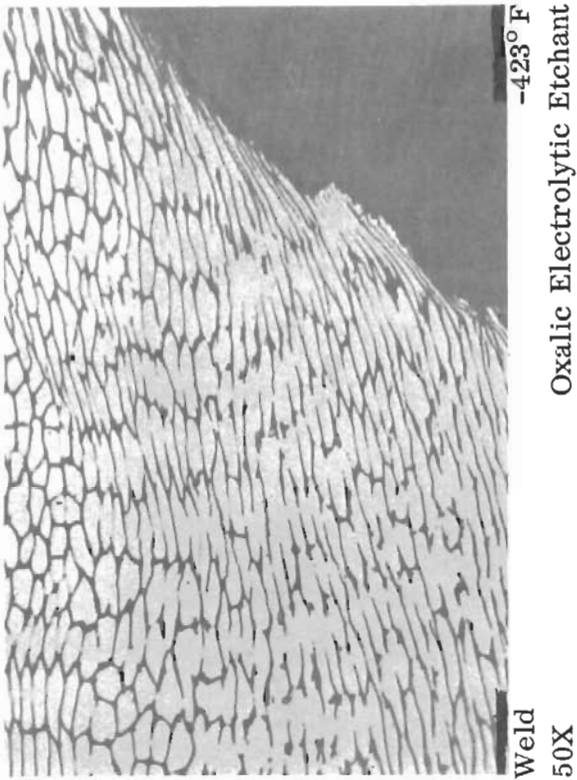
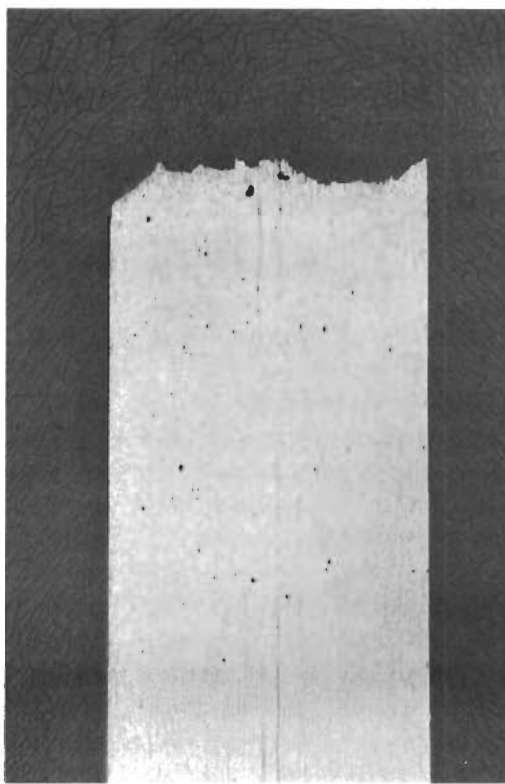
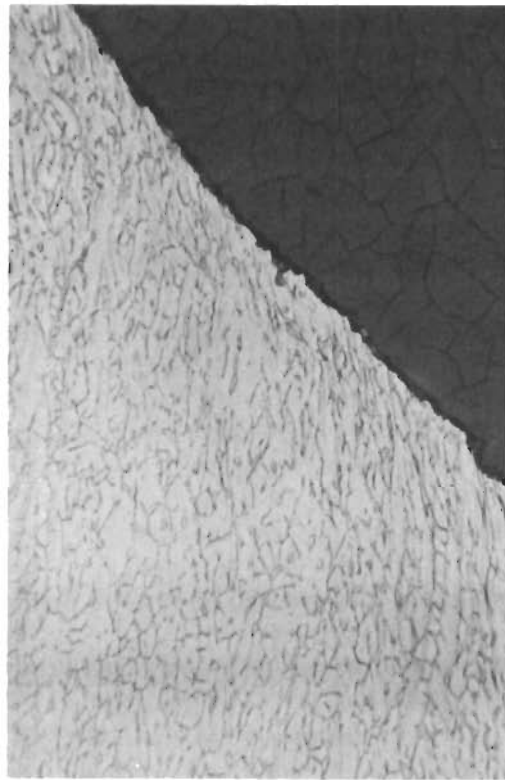

Figure 110. Photomicrographs of Fractured Tensile Specimens (310 SS)



Base Metal
50X
-320° F
Oxalic Electrolytic Etchant



Weld
500X
-100° F
Oxalic Electrolytic Etchant

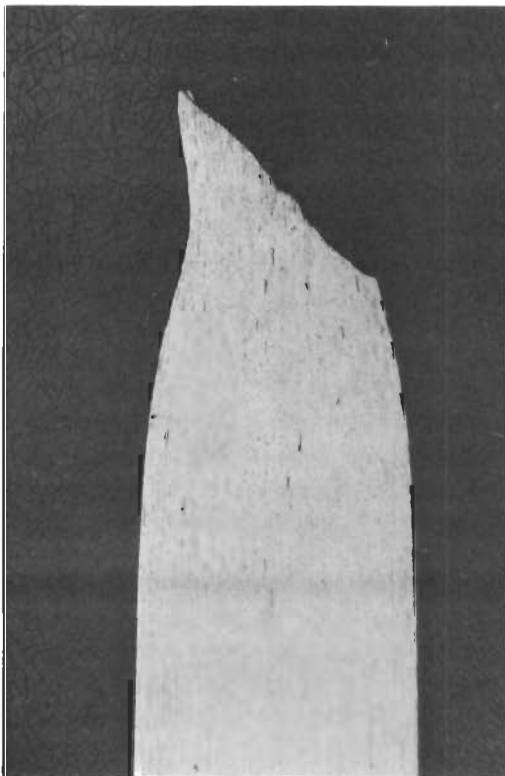

Base Metal
50X
78° F
Oxalic Electrolytic Etchant

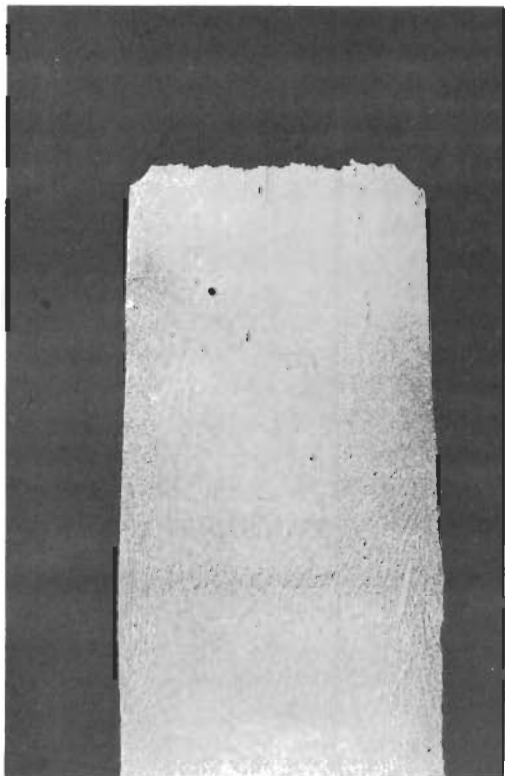

Weld
50X
-320° F
Oxalic Electrolytic Etchant

Figure 111. Photomicrographs of Fractured Tensile Specimens (AM-355 SS)

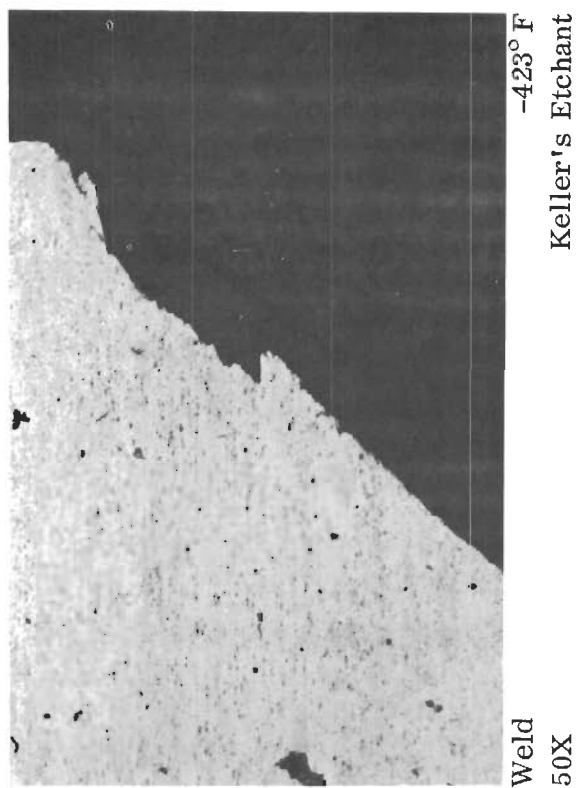
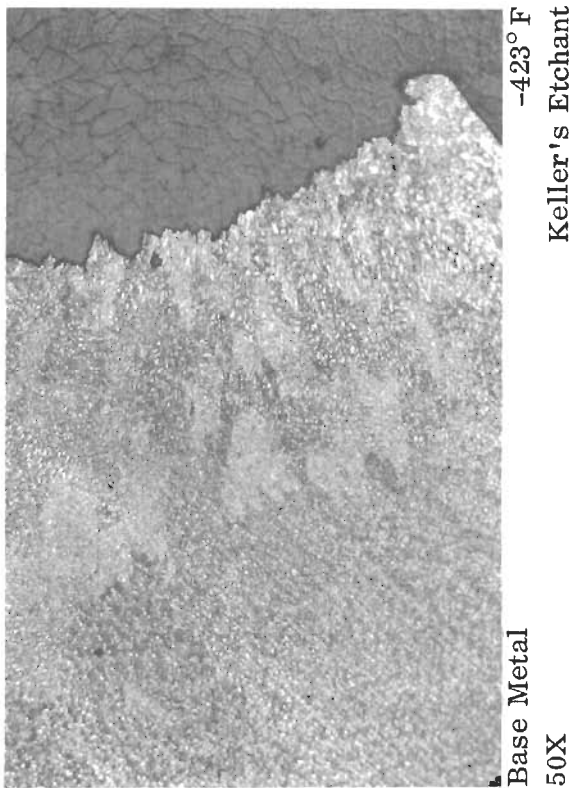
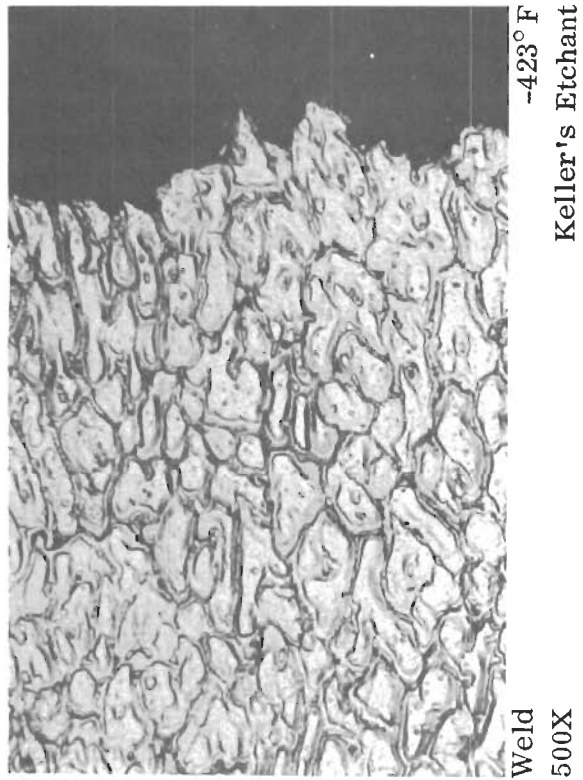
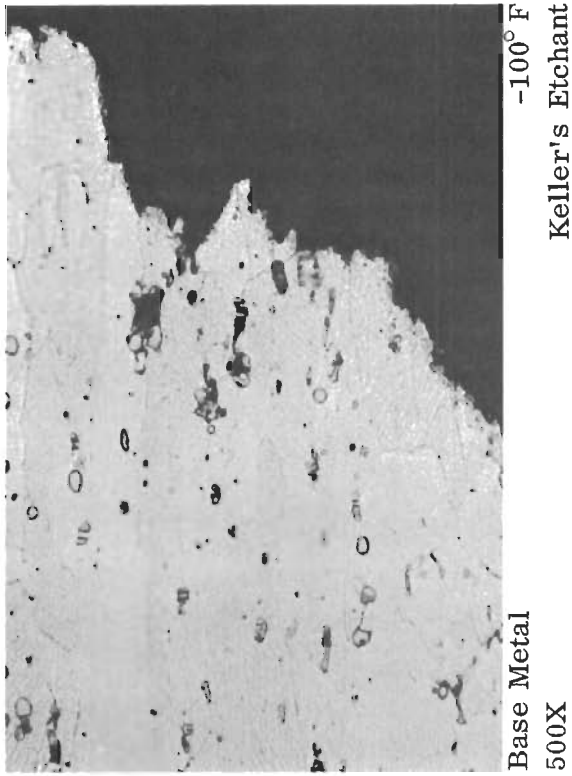

Figure 112. Photomicrographs of Fractured Tensile Specimens (2014-T6 Al Alloy)

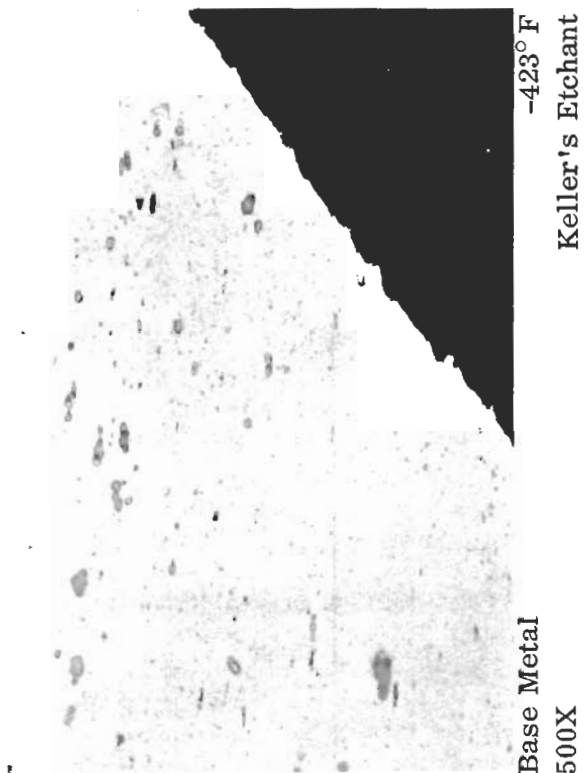
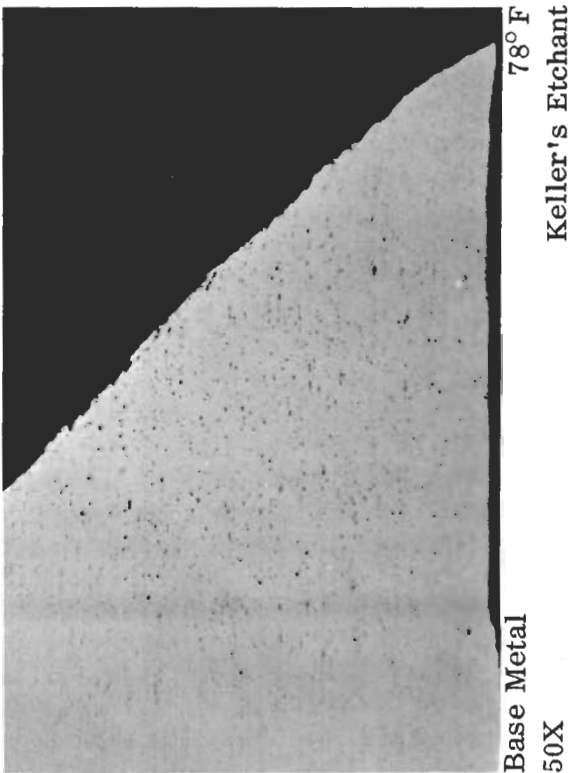
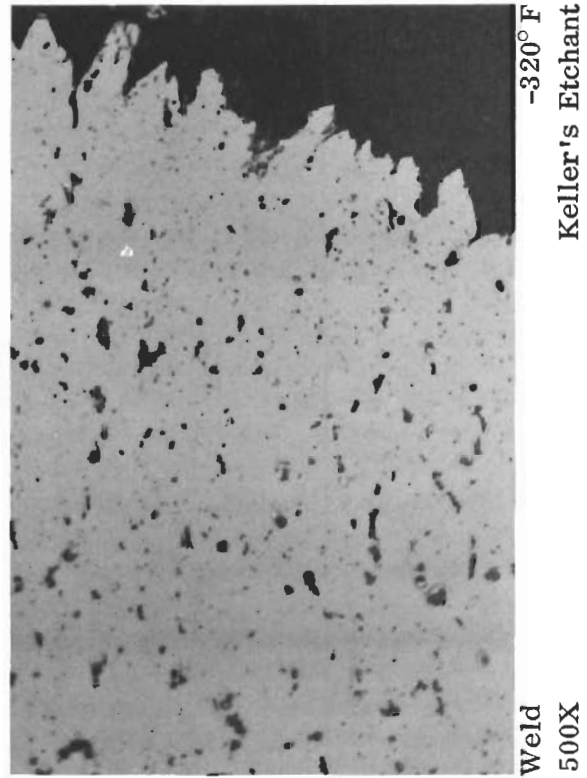
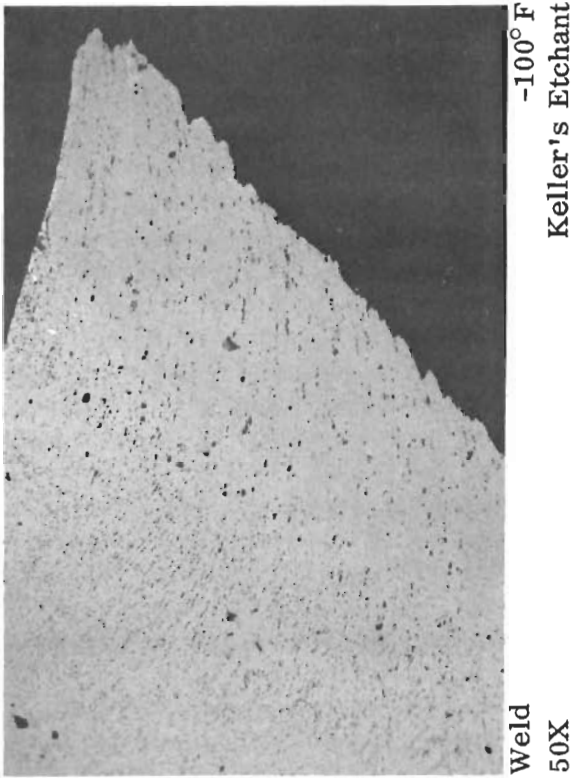

Figure 113. Photomicrographs of Fractured Tensile Specimens (5052-H38 Al Alloy)

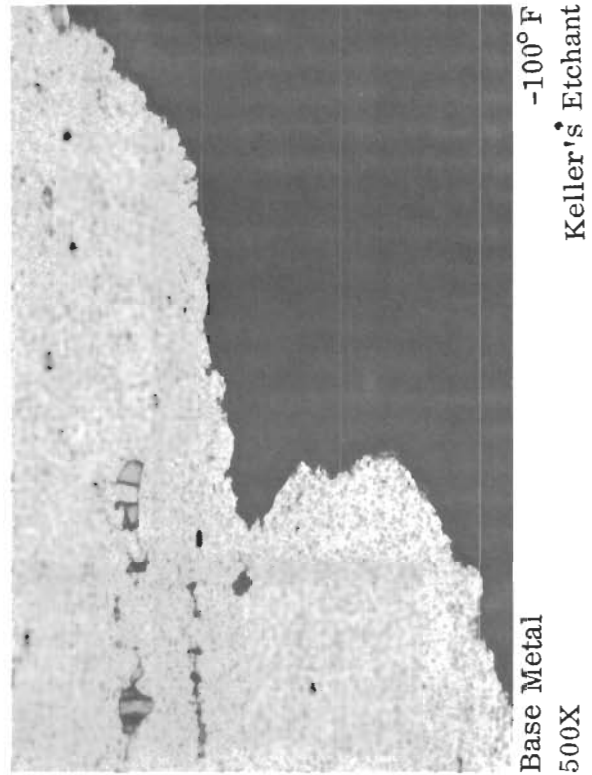
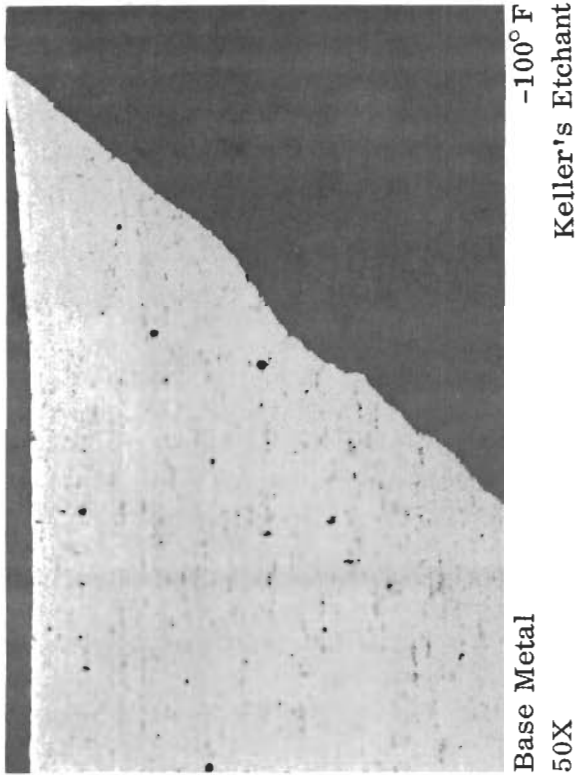
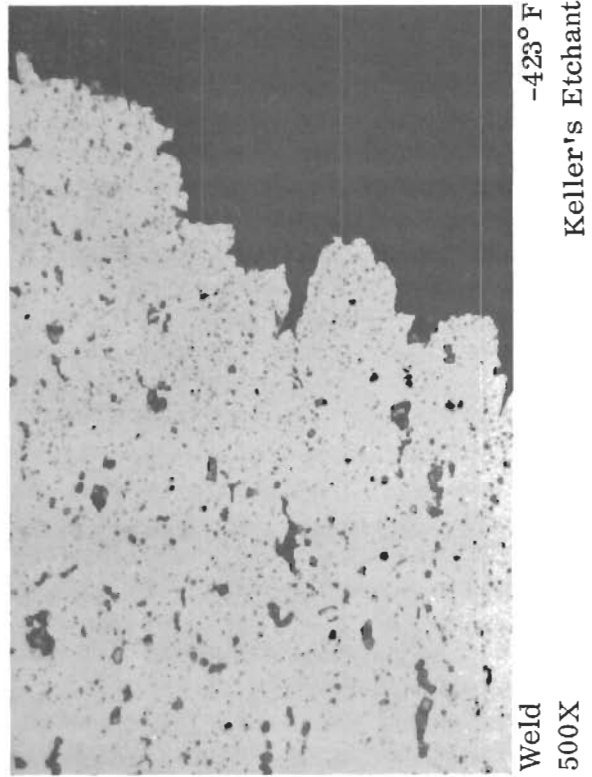
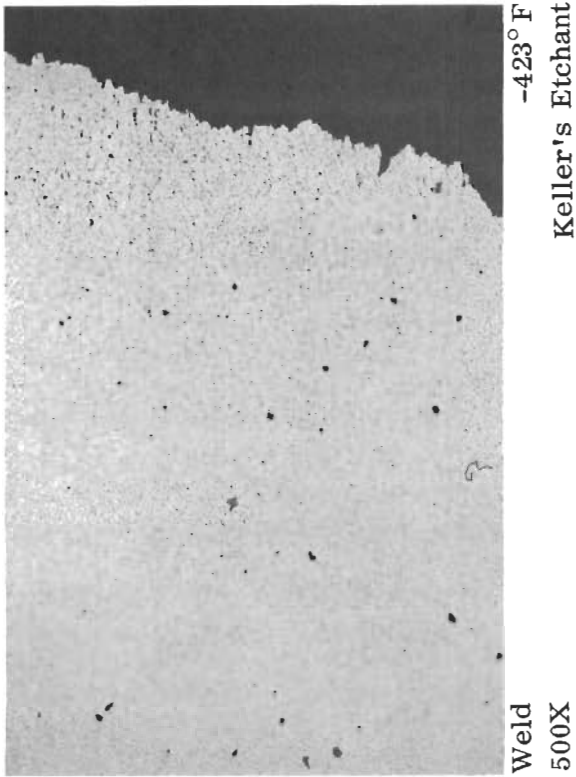
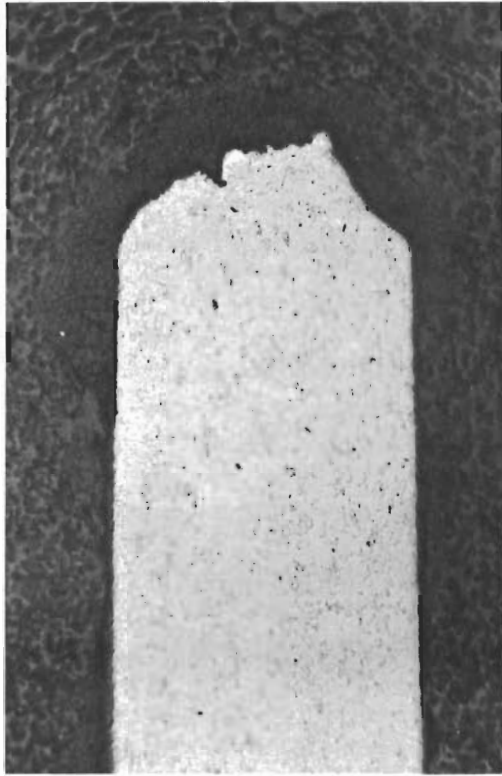
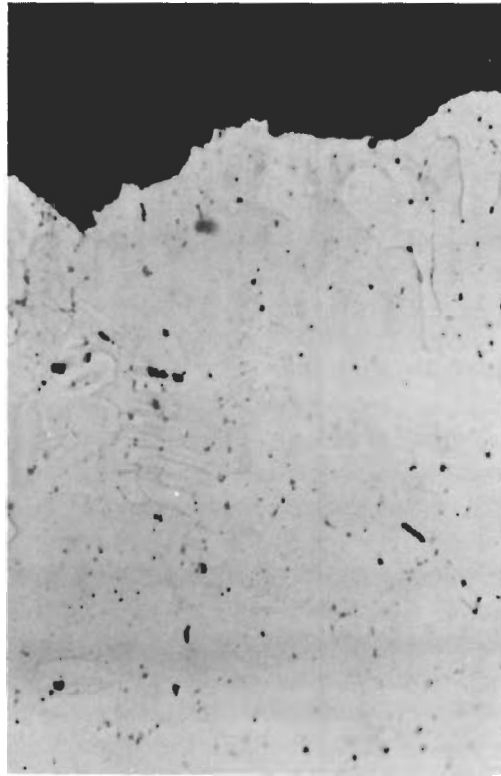

Figure 114. Photomicrographs of Fractured Tensile Specimens (5456-H343 Al Alloy)



Base Metal
50X
-320° F
Kroll's Etchant



Base Metal
500X
-423° F
Kroll's Etchant

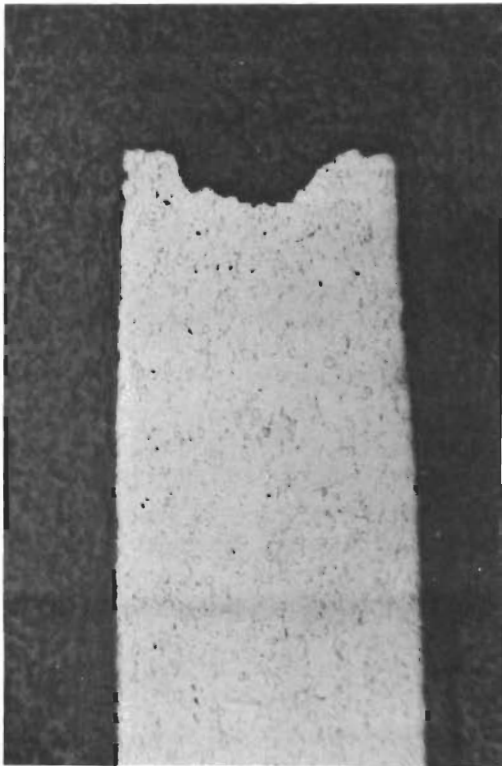

Base Metal
50X
78° F
Kroll's Etchant

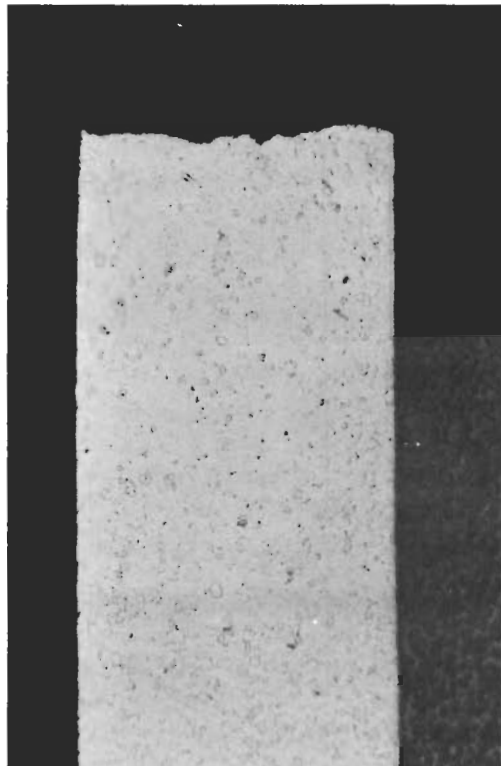

Base Metal
50X
-423° F
Kroll's Etchant

Figure 115. Photomicrographs of Fractured Tensile Specimens (Ti-5Al-2.4Sn Alloy)

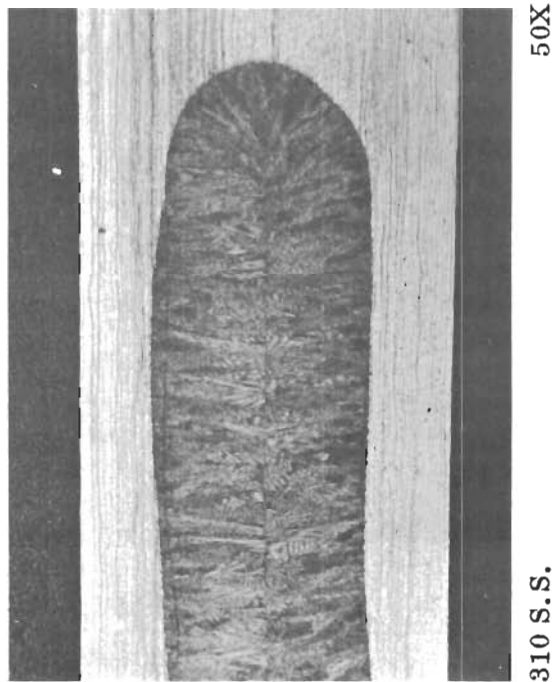
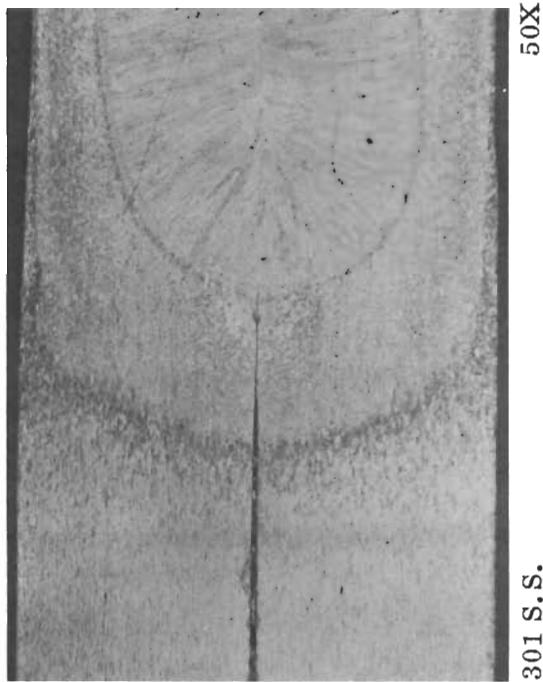
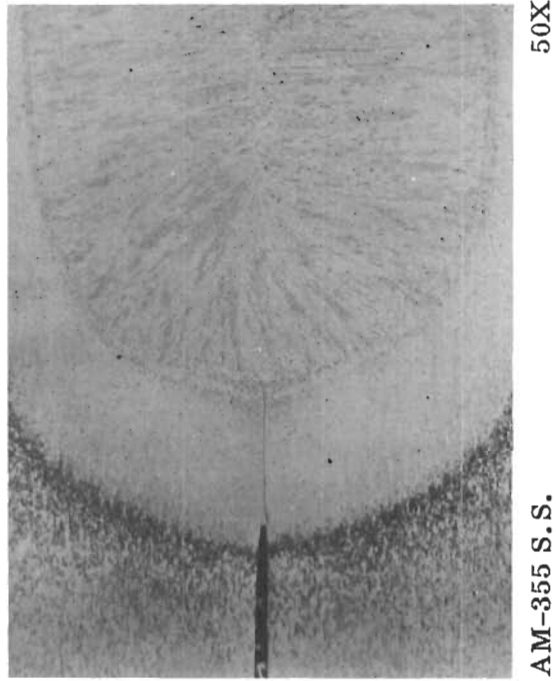
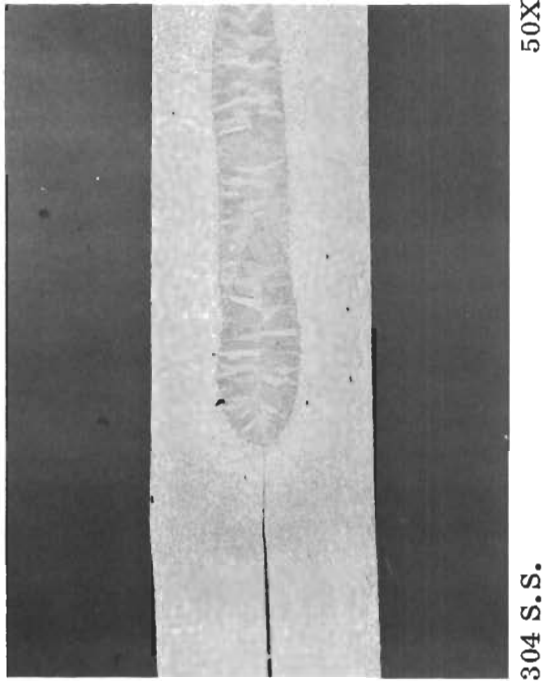

Figure 116. Photomicrographs of Resistance Spot Welds (50X)

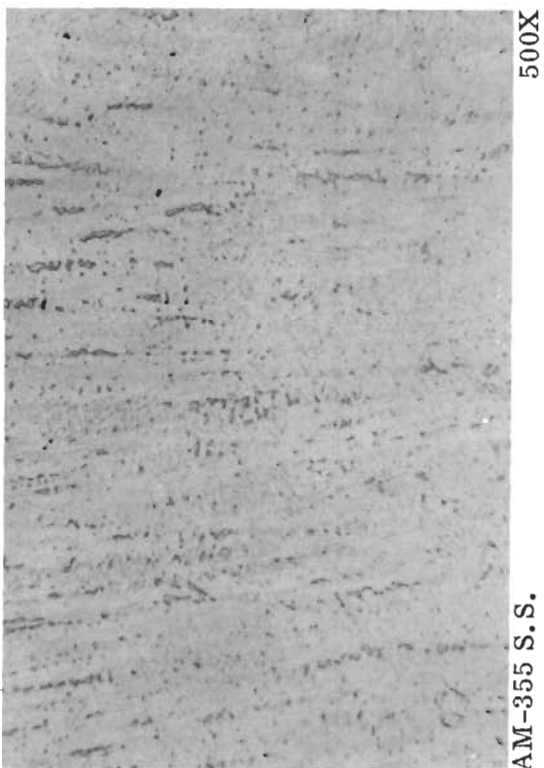
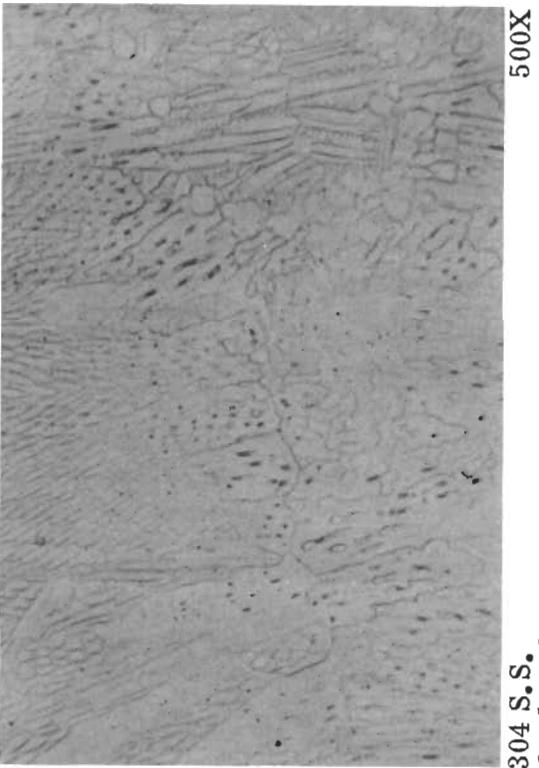
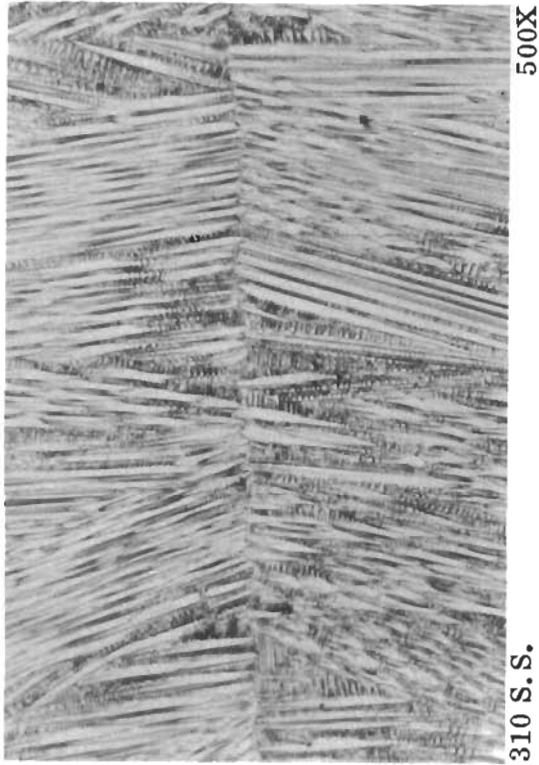

Figure 117. Photomicrographs of Resistance Spot Welds (500X)

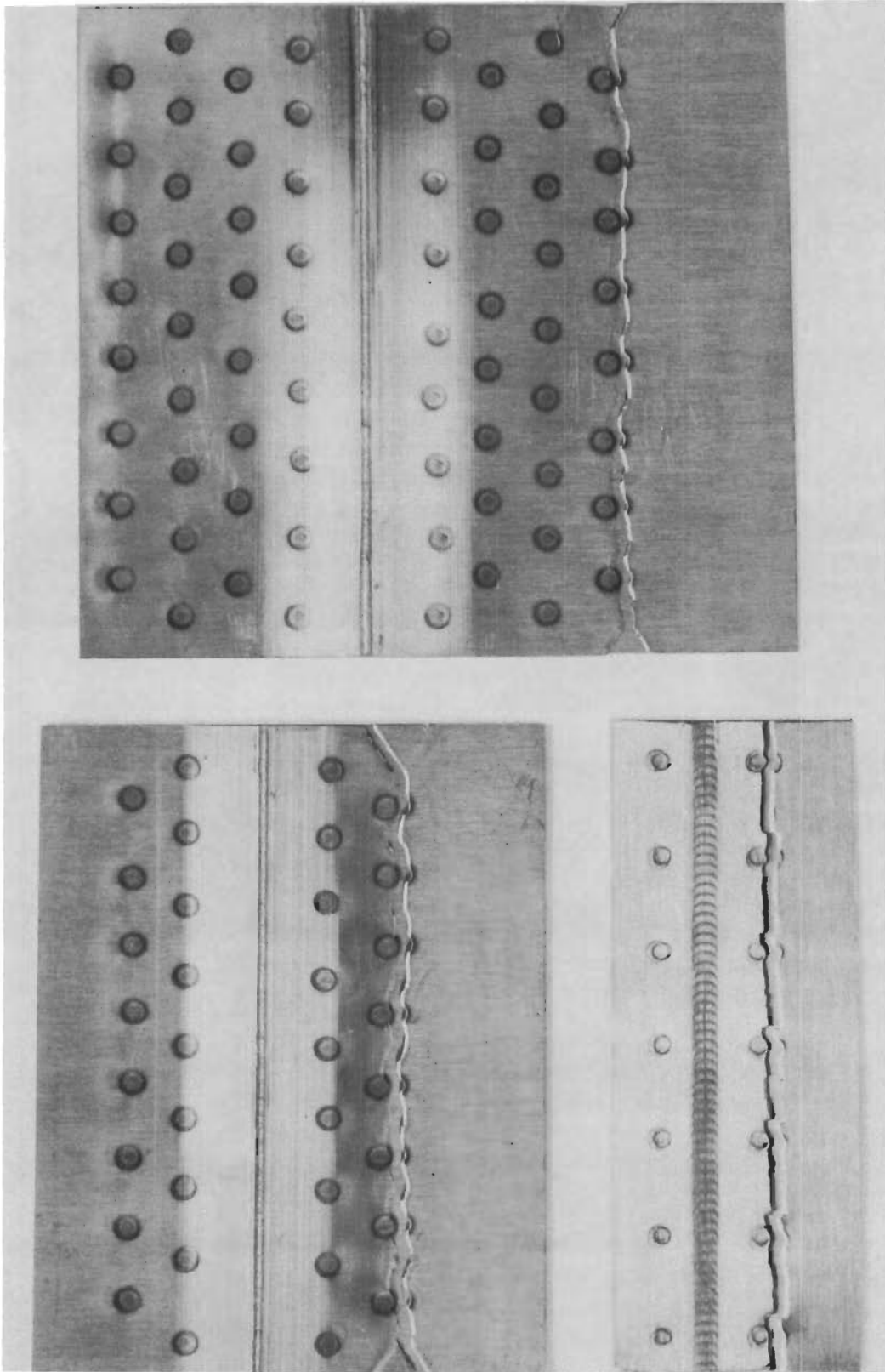

Figure 118. Fractured Fatigue Specimens - 301 SS (78°F)

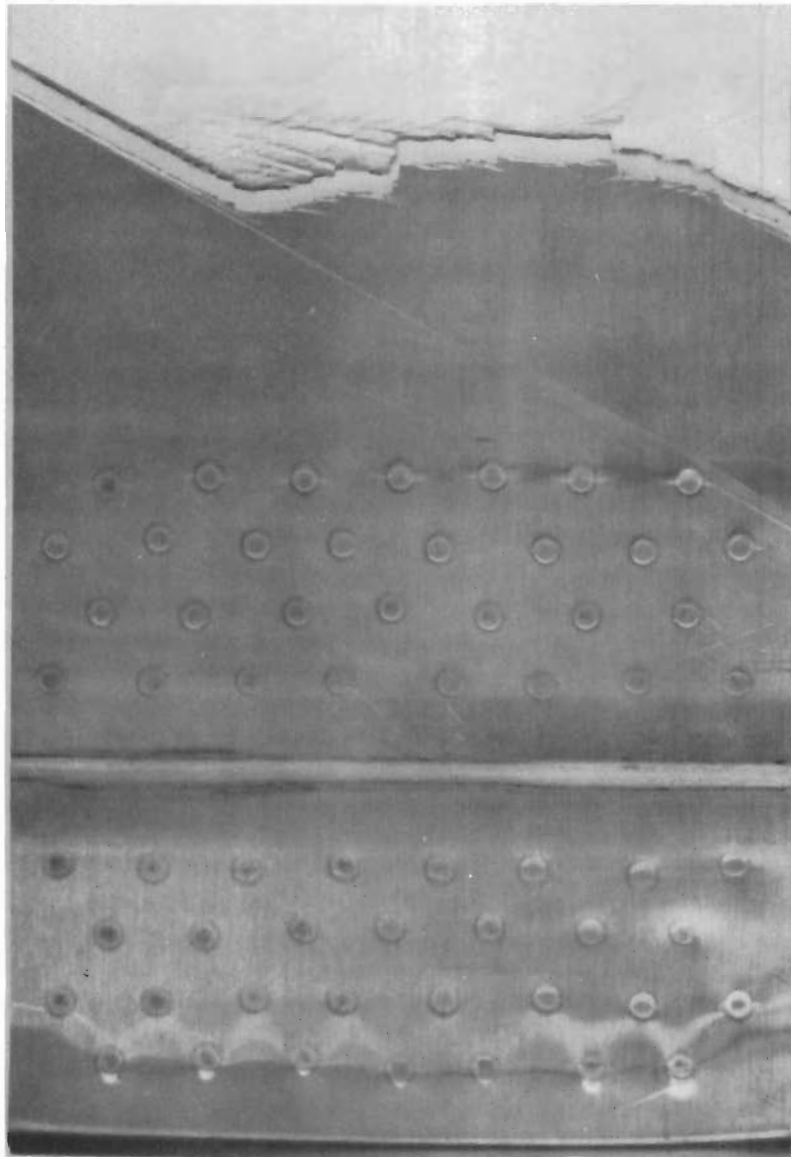

Figure 119. Fractured Fatigue Specimen - 301 SS

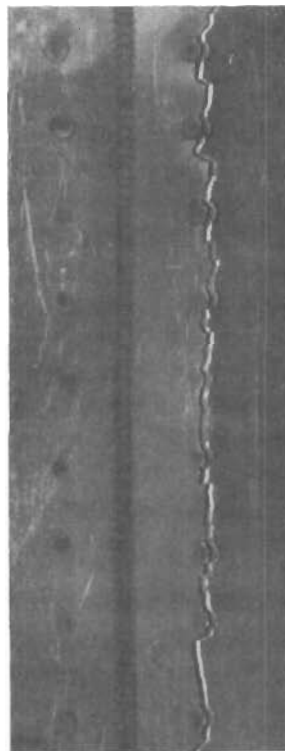
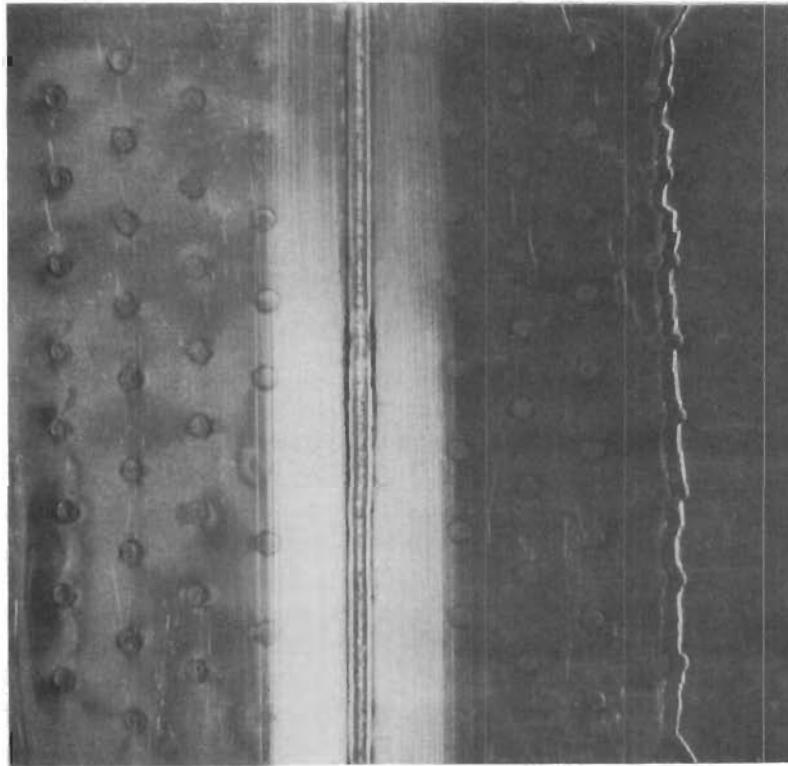

Figure 120. Fractured Fatigue Specimens - 304 SS (78° F)

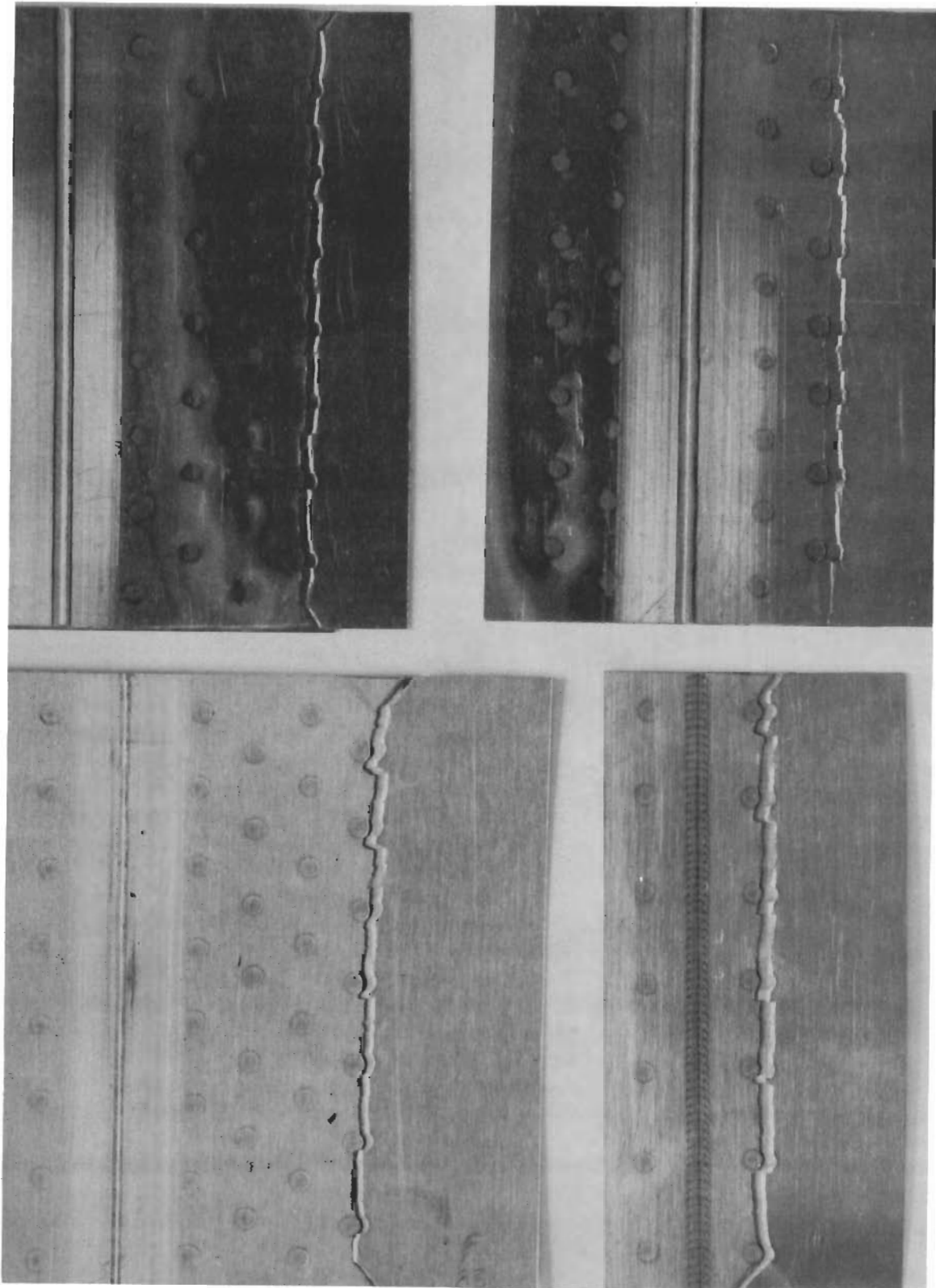

Figure 121. Fractured Fatigue Specimens - 310 SS (78° F)

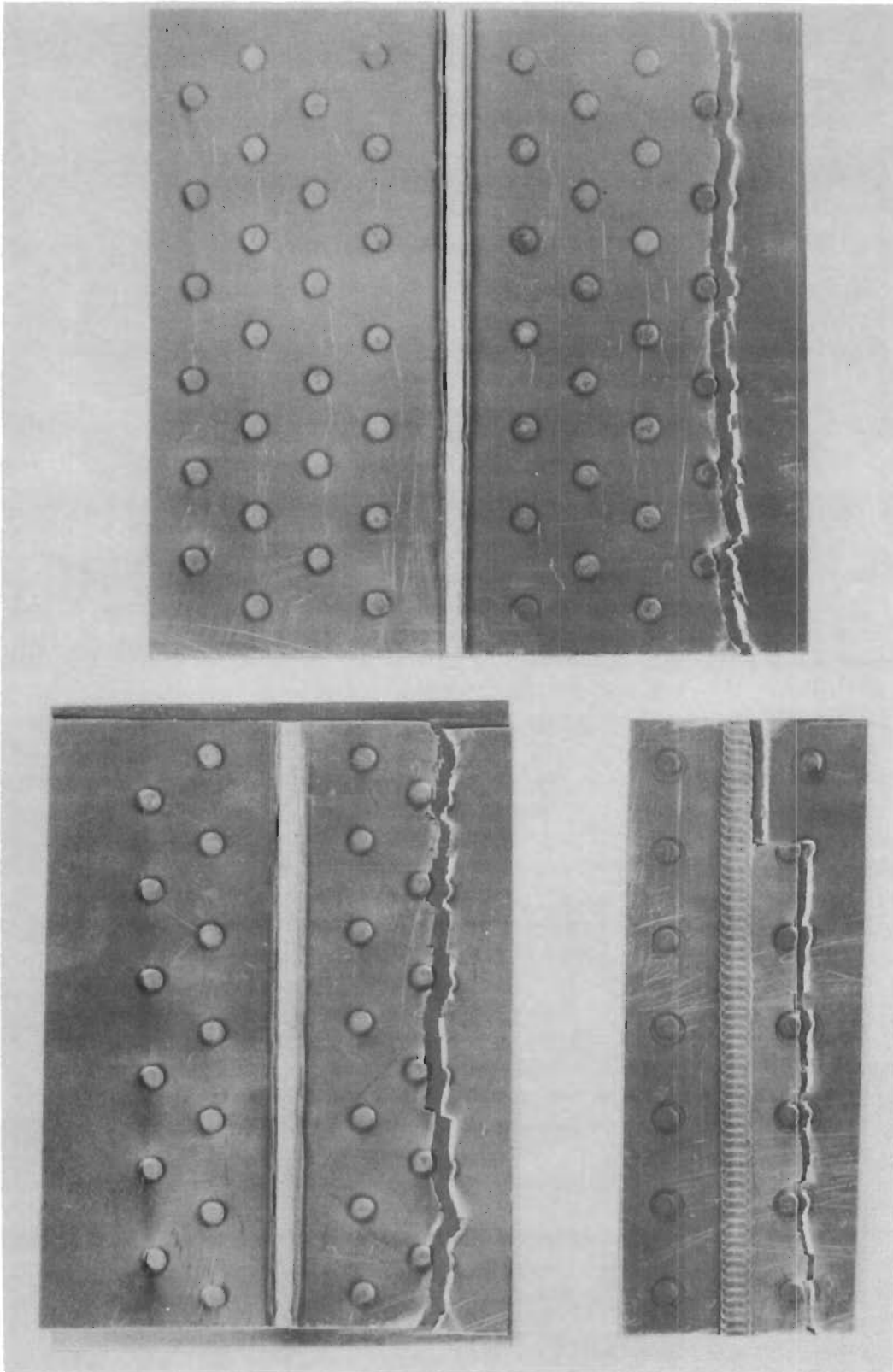

Figure 122. Fractured Fatigue Specimens - AM-355 SS (78° F)

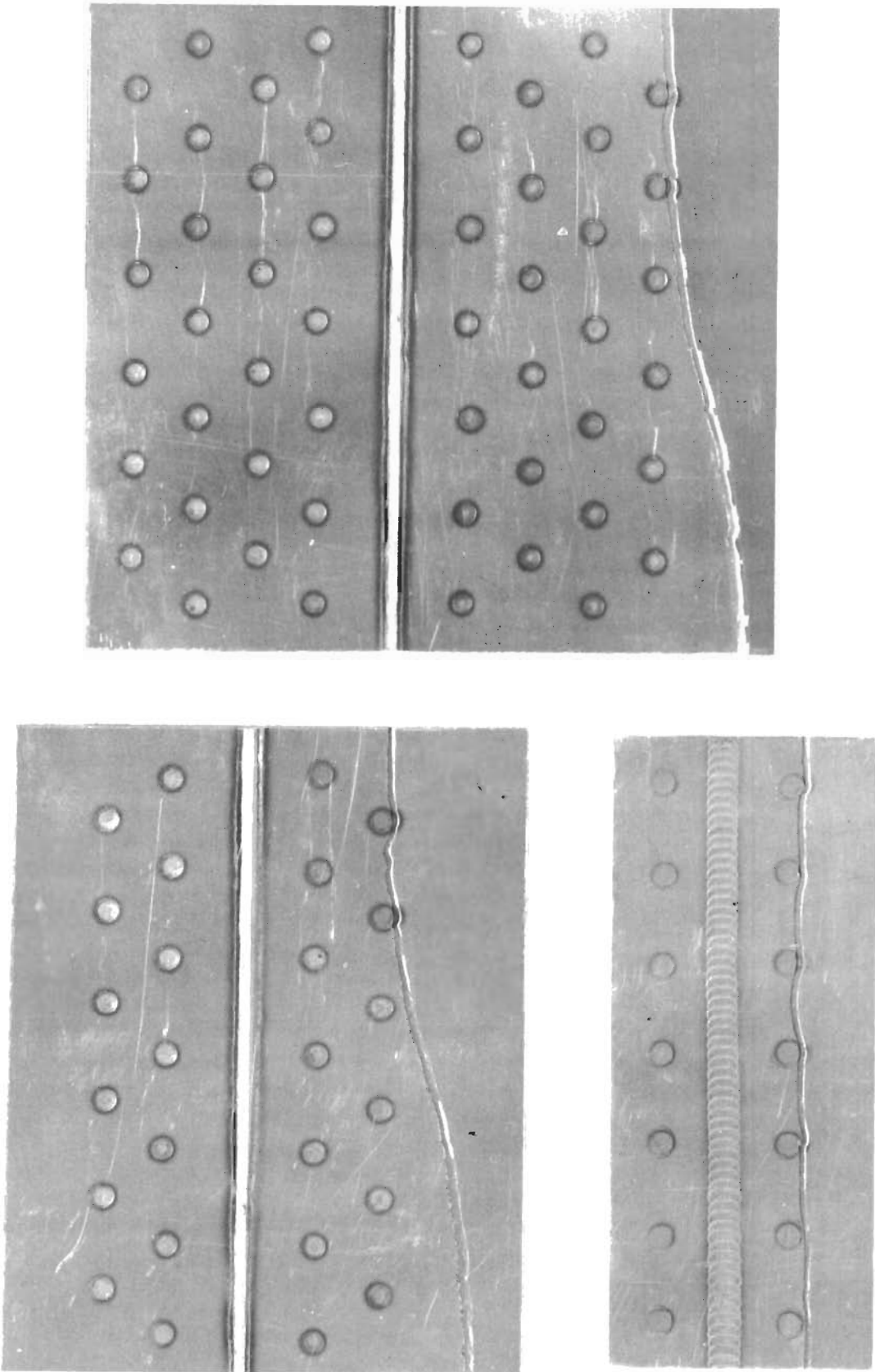

Figure 123. Fractured Fatigue Specimens - AM-355 SS (-423° F)

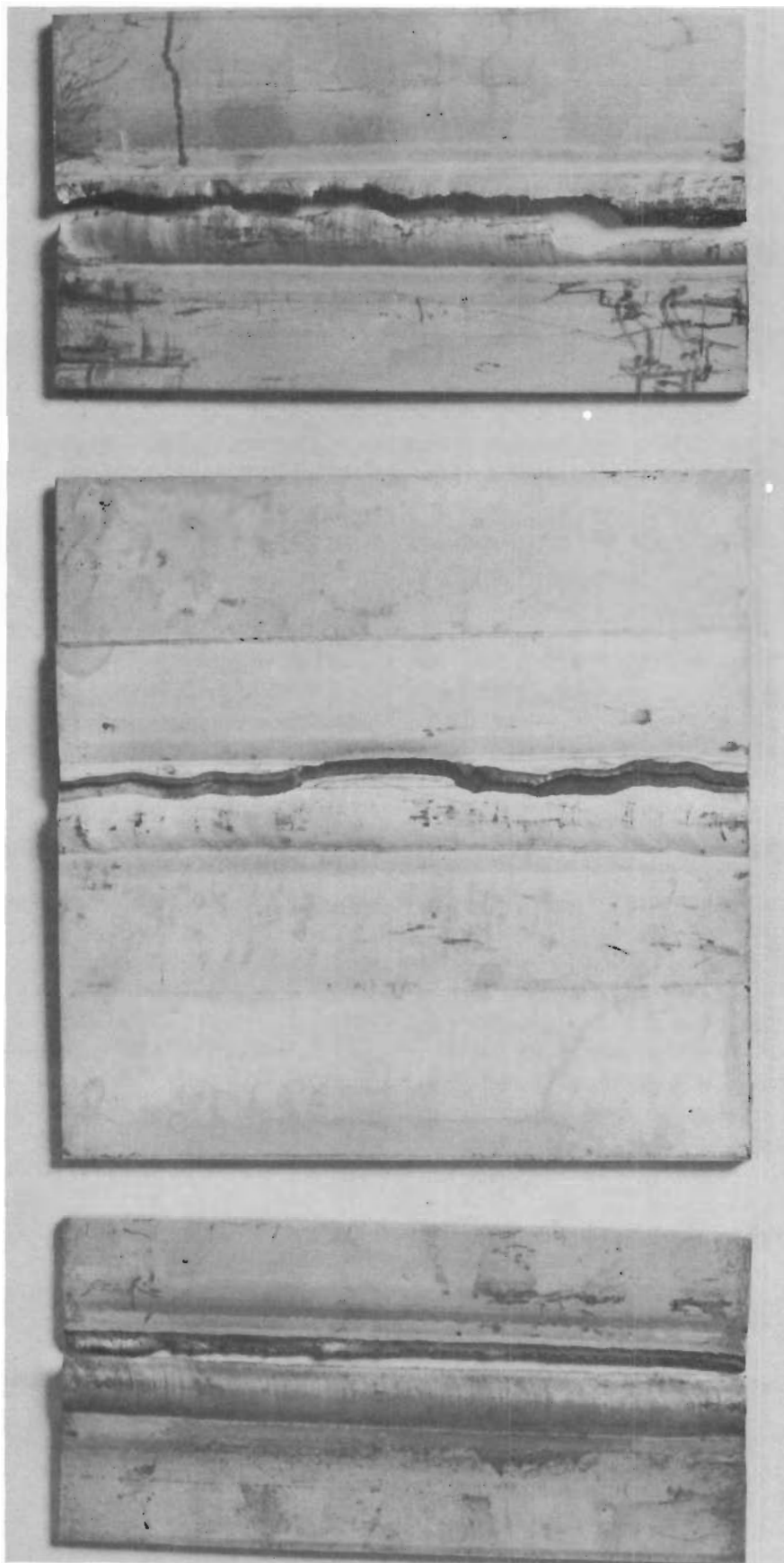

Figure 124. Fractured Fatigue Specimens - 2014-T6 Aluminum Alloy (78° F)

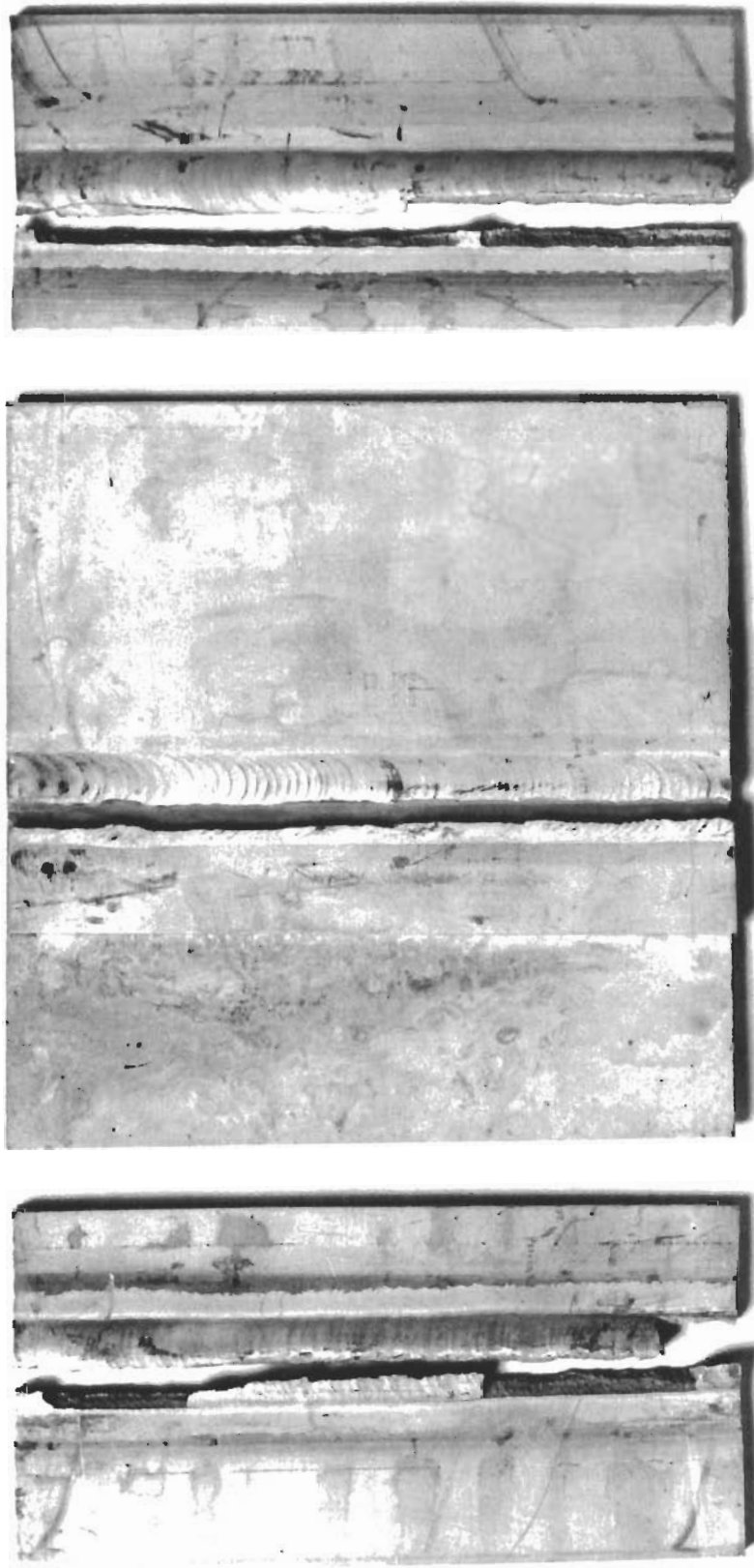

Figure 125. Fractured Fatigue Specimens - 2014-T6 Aluminum Alloy (-423° F)

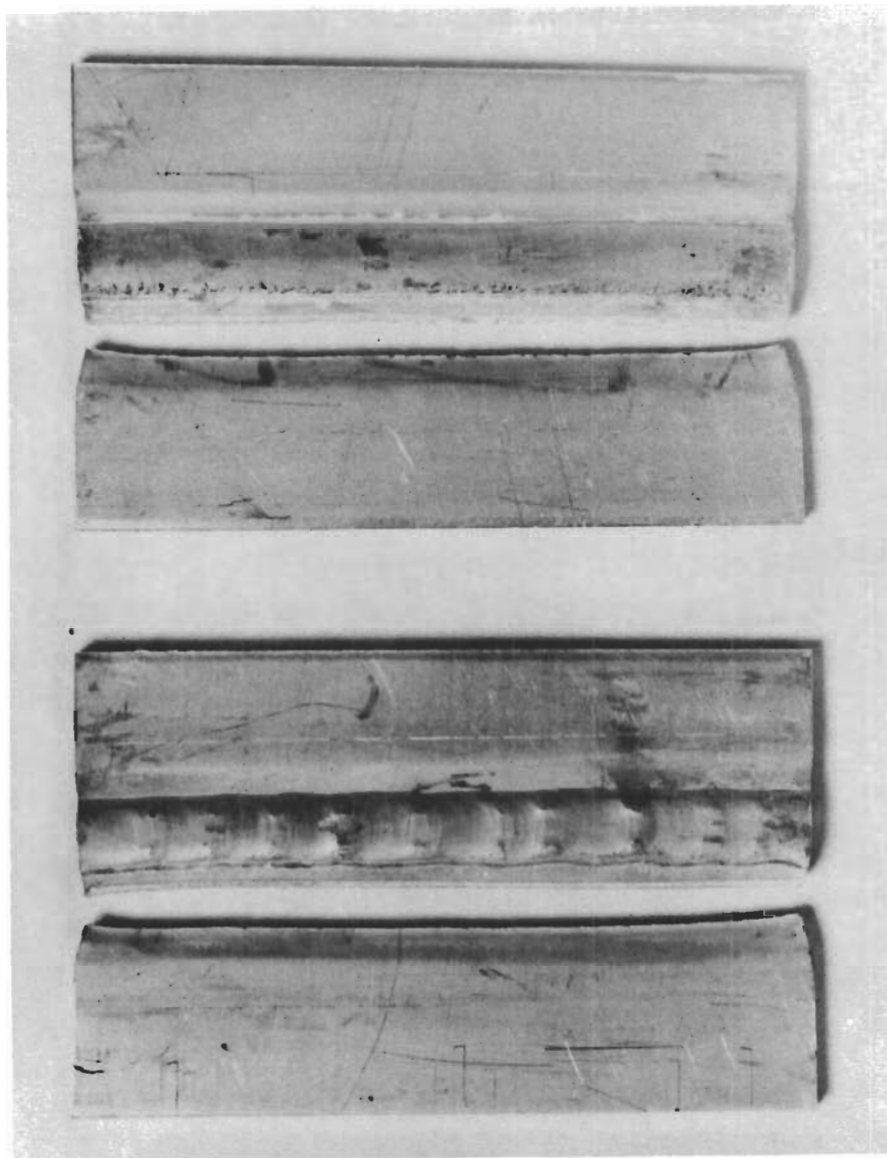

Figure 126. Fractured Fatigue Specimens 5052-H38 Aluminum Alloy (78° F)

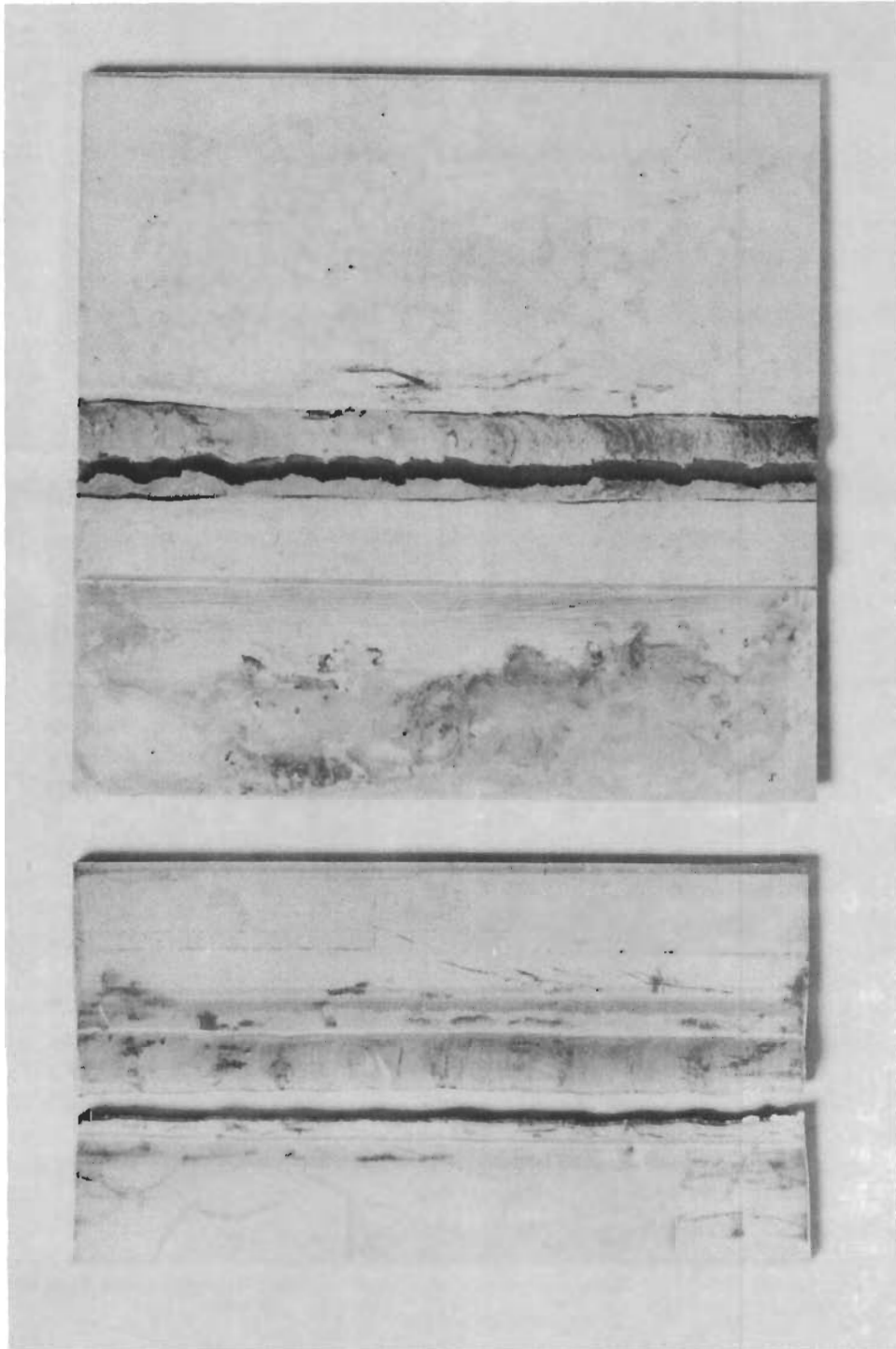

Figure 127. Fractured Fatigue Specimens - 5456-H343 Aluminum Alloy (-320° F)

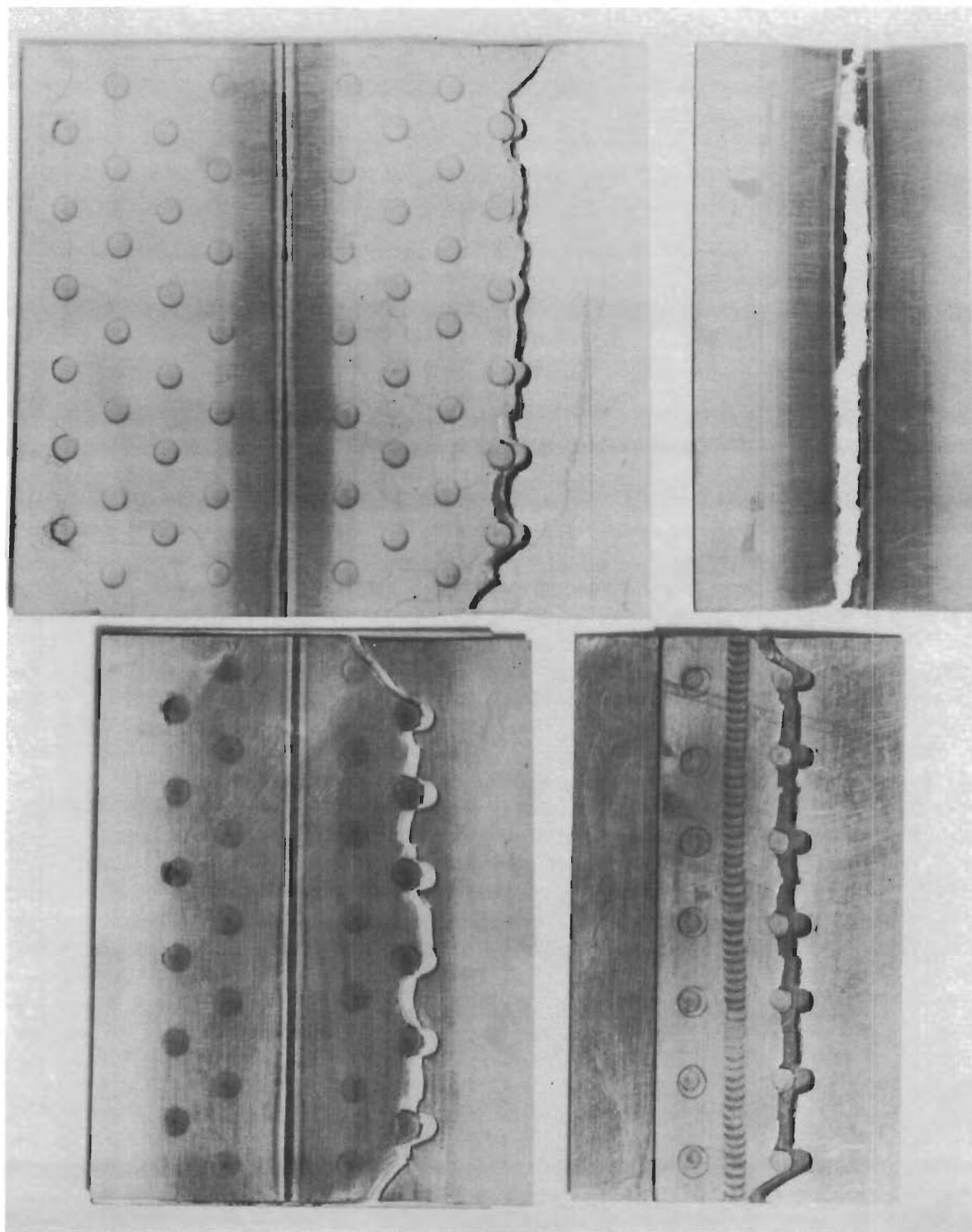

Figure 128. Fractured Fatigue Specimens - Ti-5Al-2.5Sn Alloy (78° F)

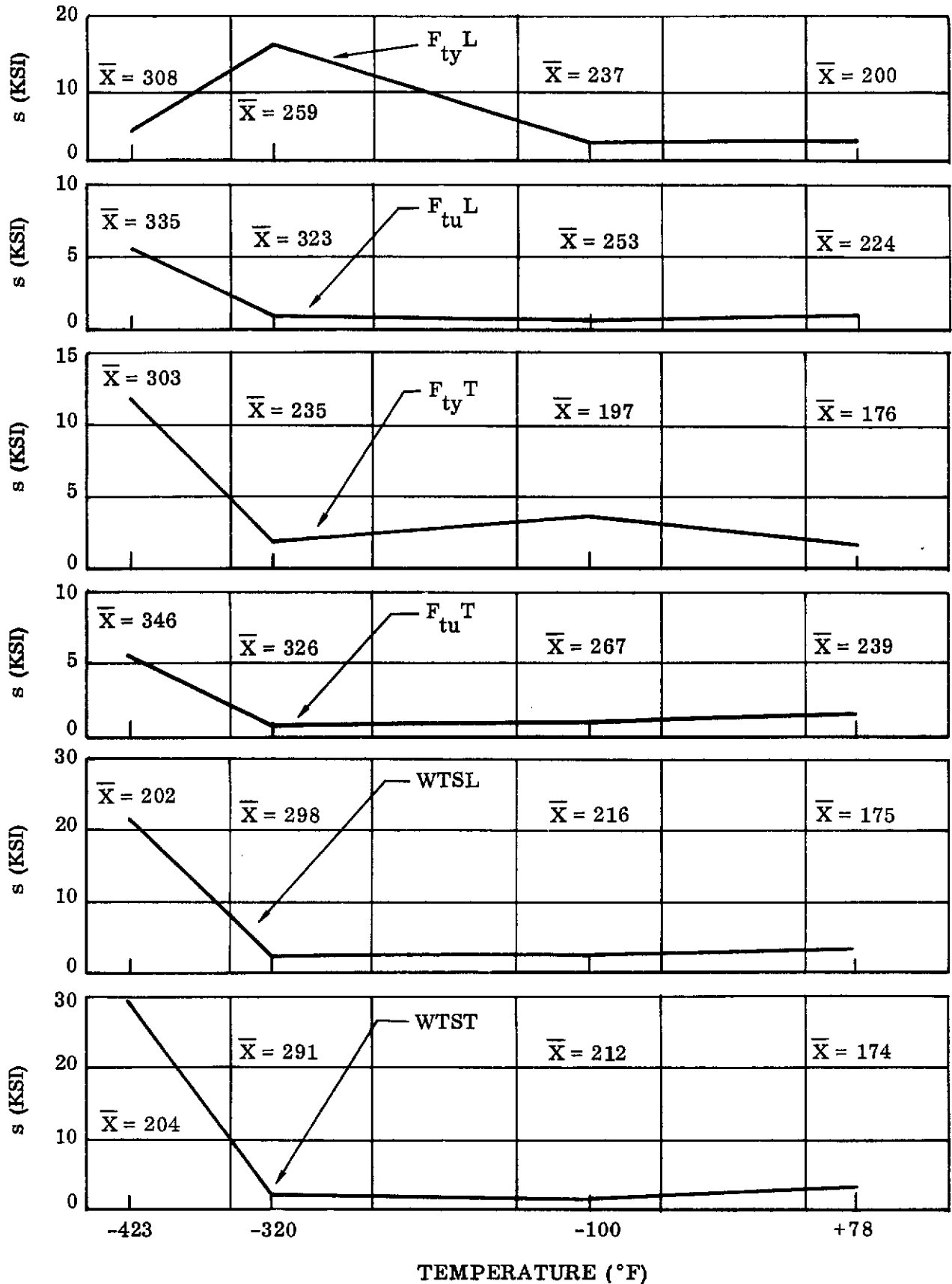

Figure 129. Standard Deviations Versus Temperature (301 SS)

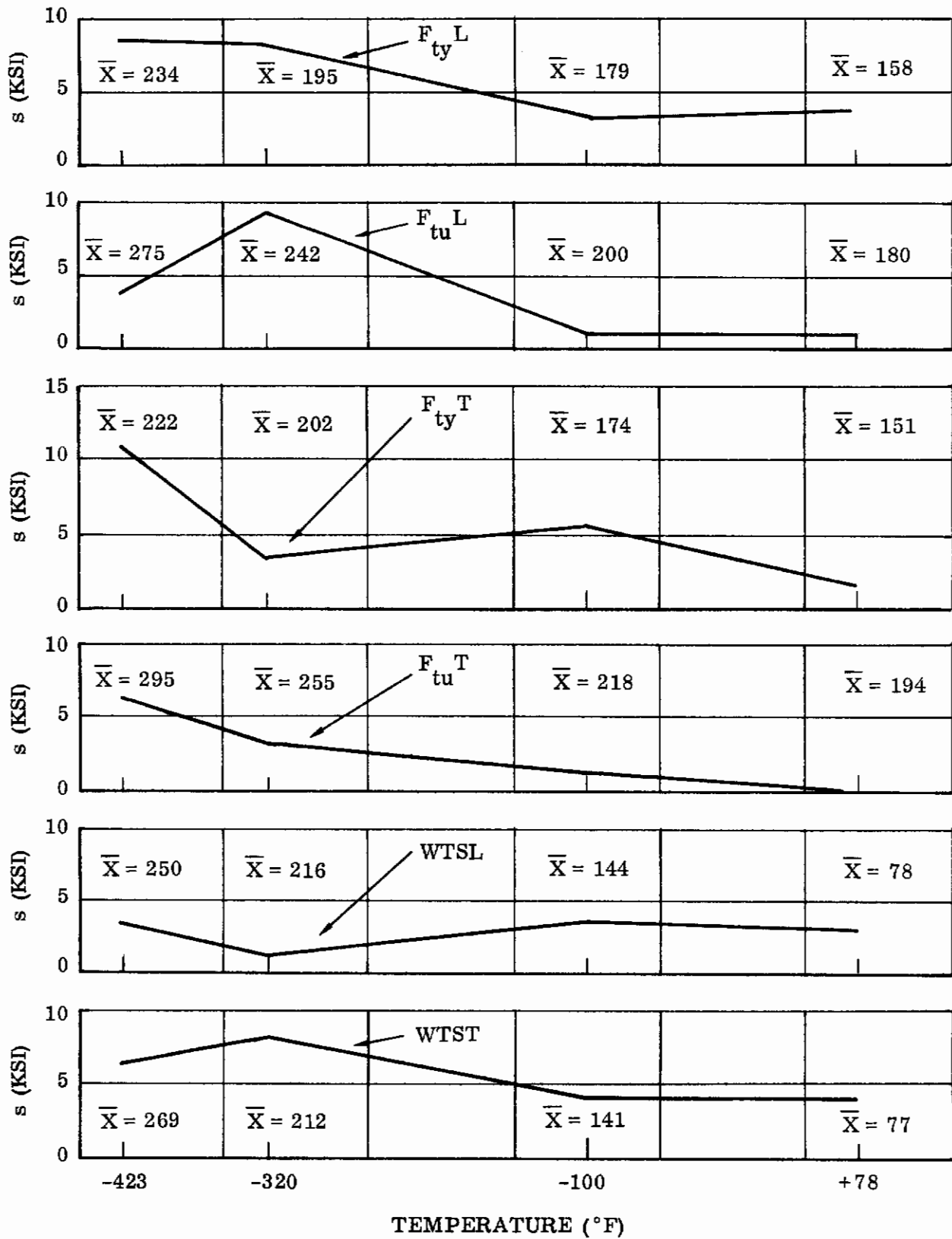

Figure 130. Standard Deviations Versus Temperature (304 SS)

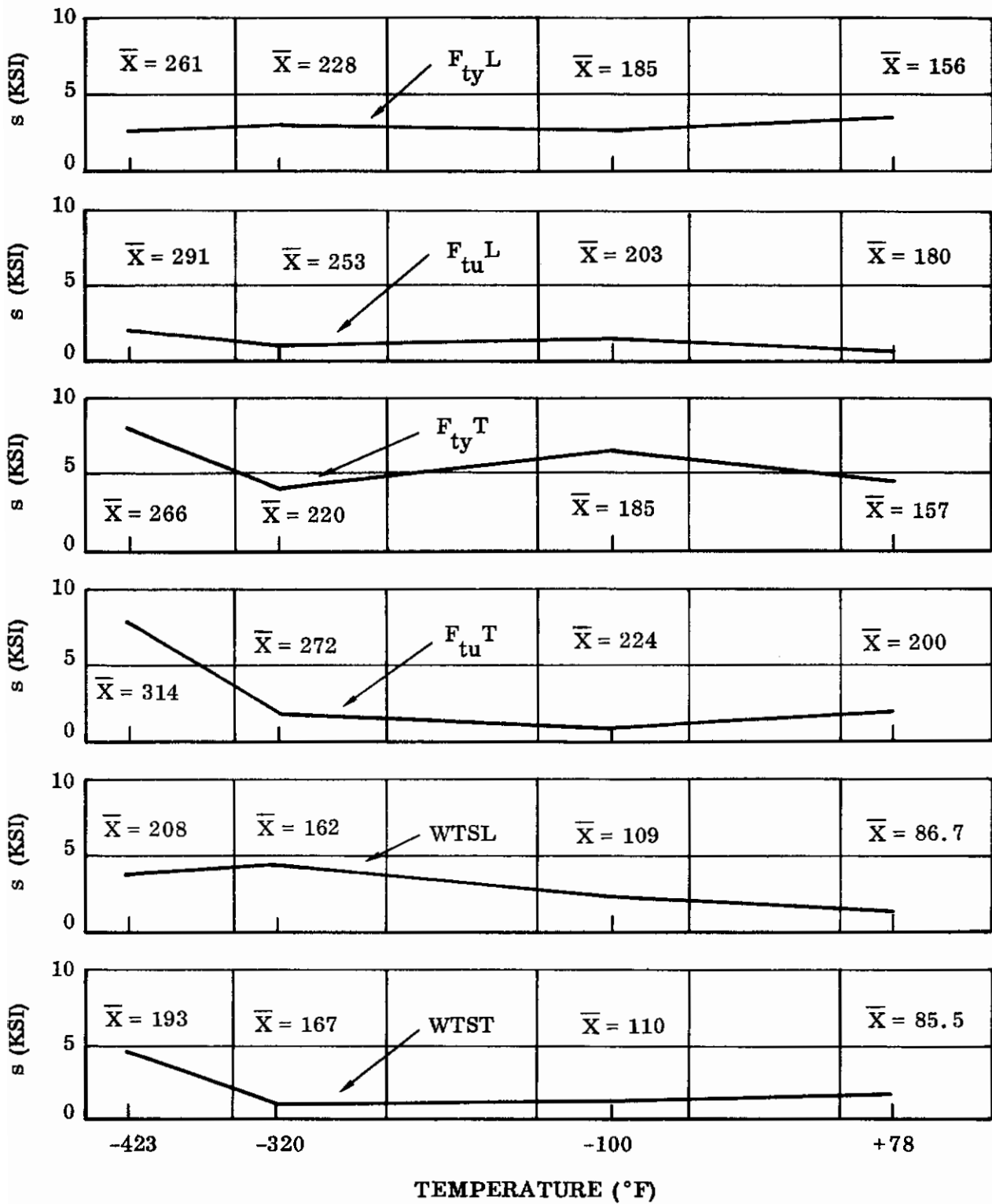

Figure 131. Standard Deviations Versus Temperature (310 SS)

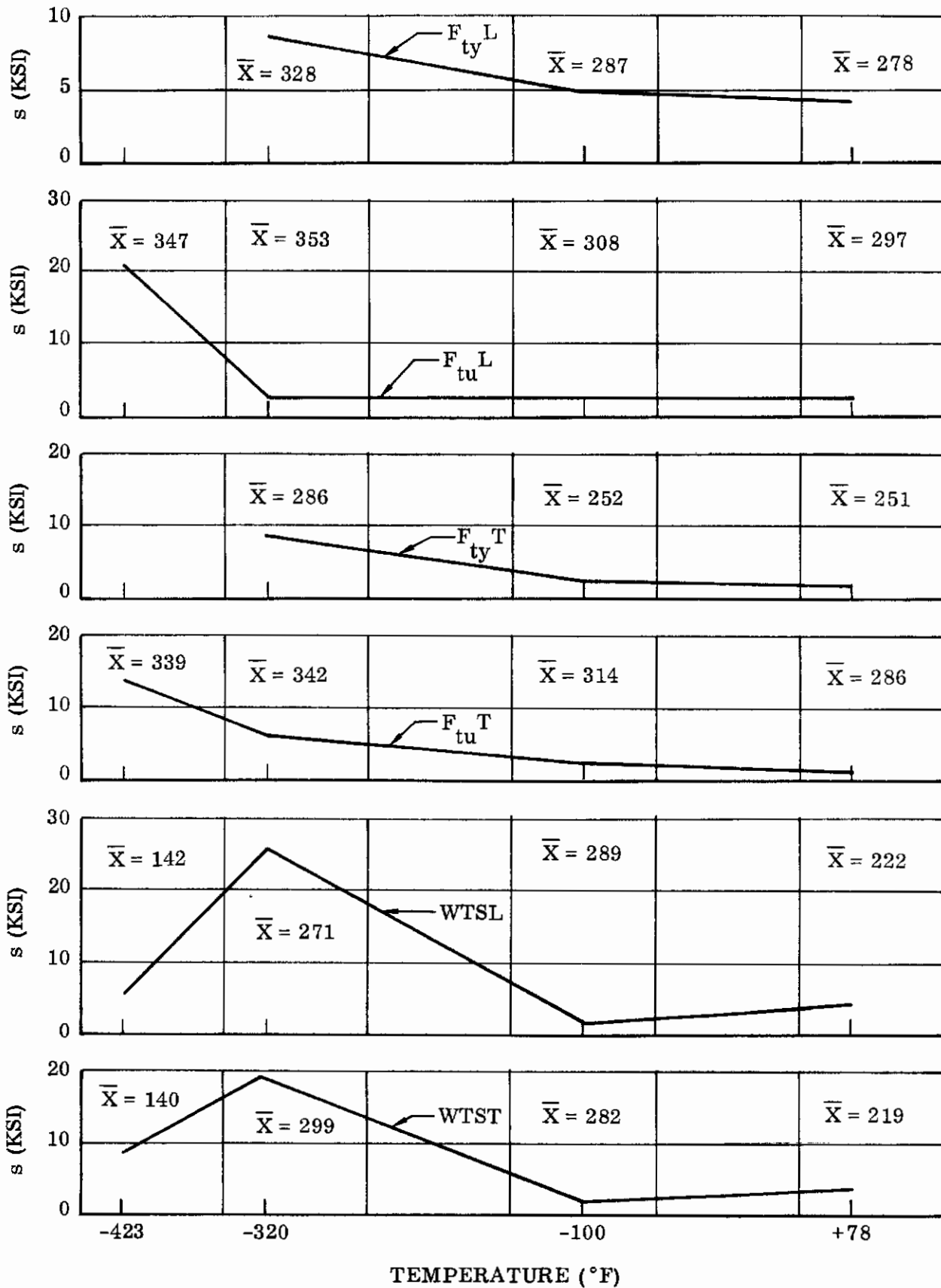

Figure 132. Standard Deviations Versus Temperature (AM-355 SS)

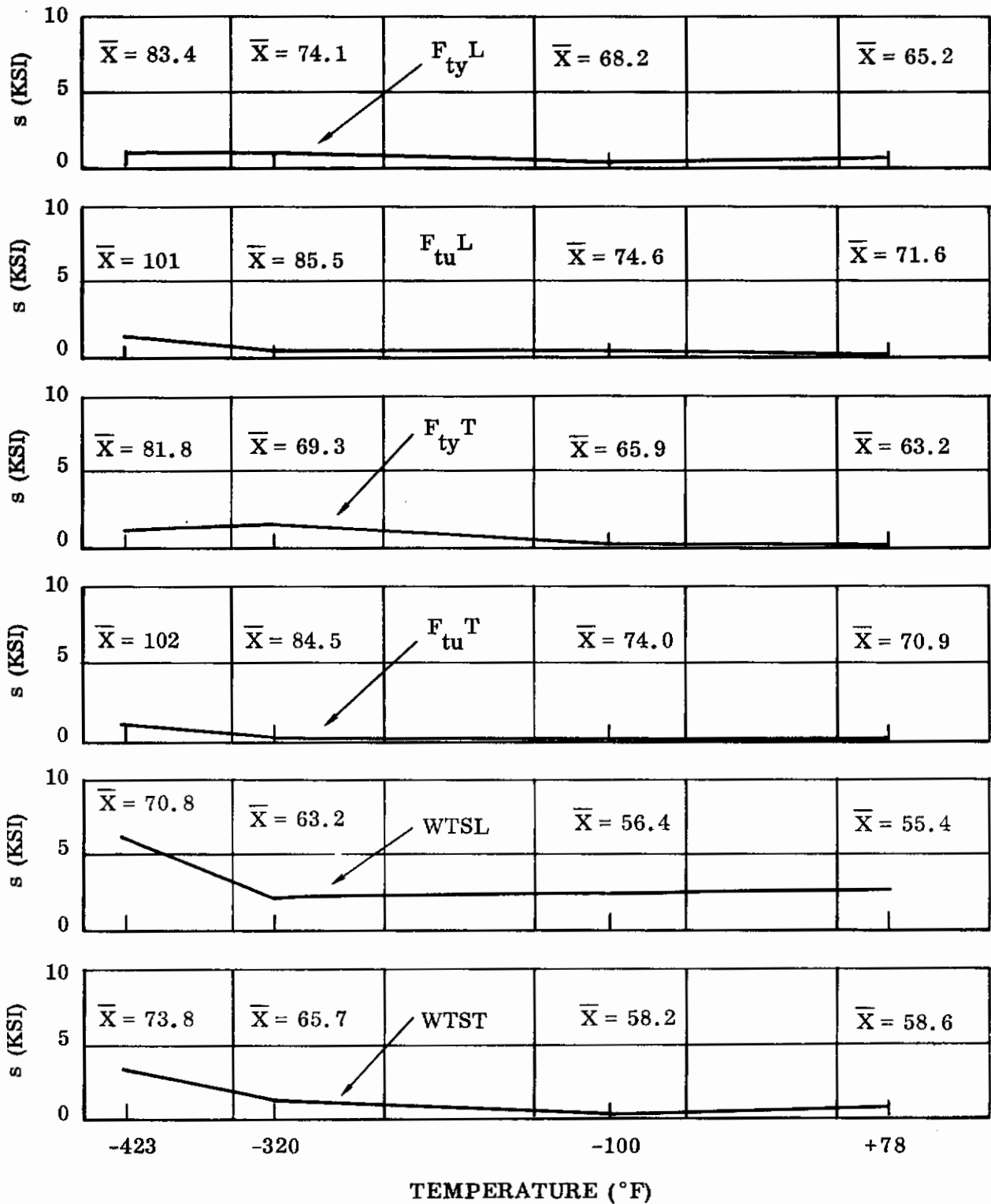

Figure 133. Standard Deviations Versus Temperature (2014-T6 Aluminum Alloy)

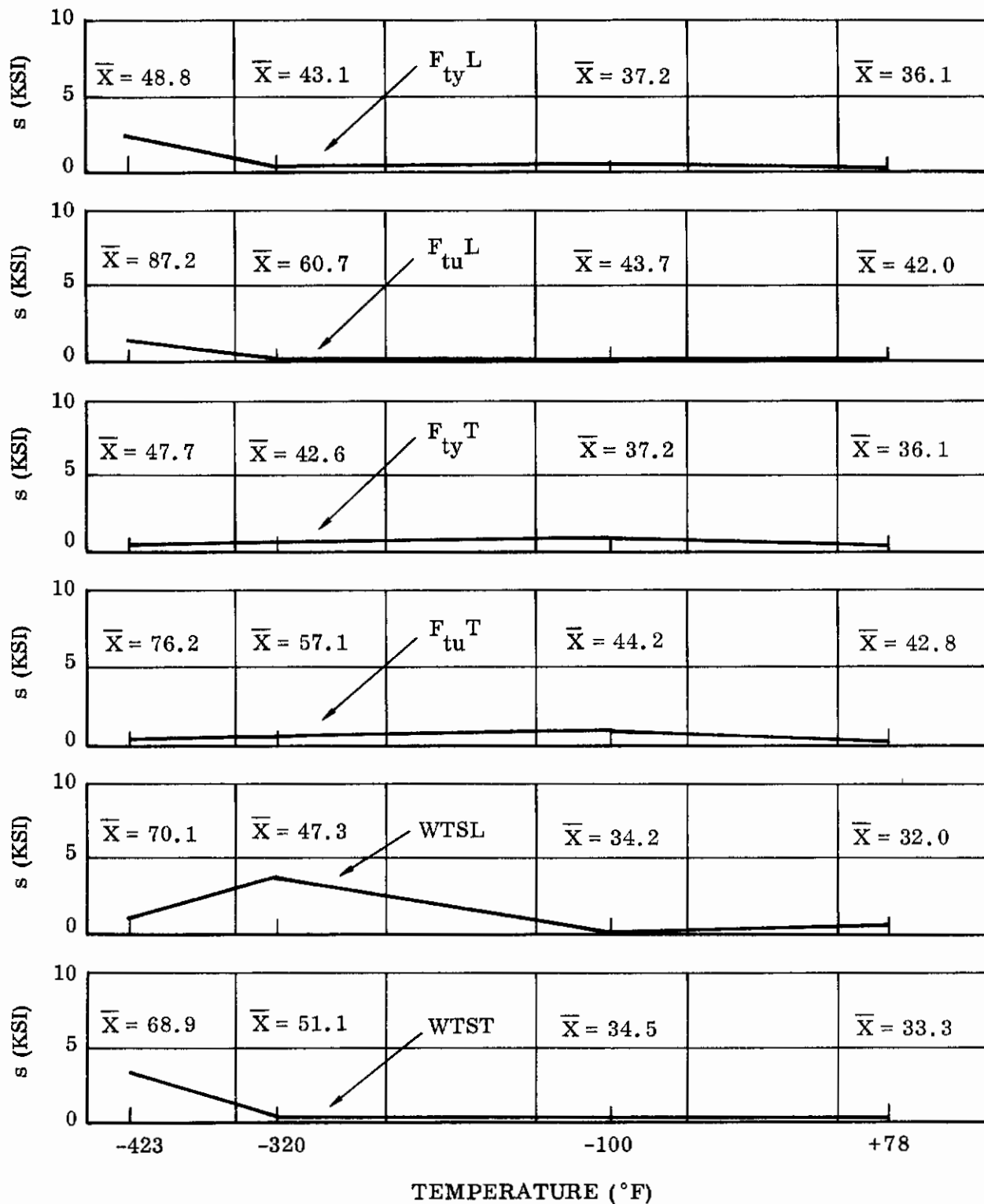

Figure 134. Standard Deviations Versus Temperature (5052-H38 Aluminum Alloy)

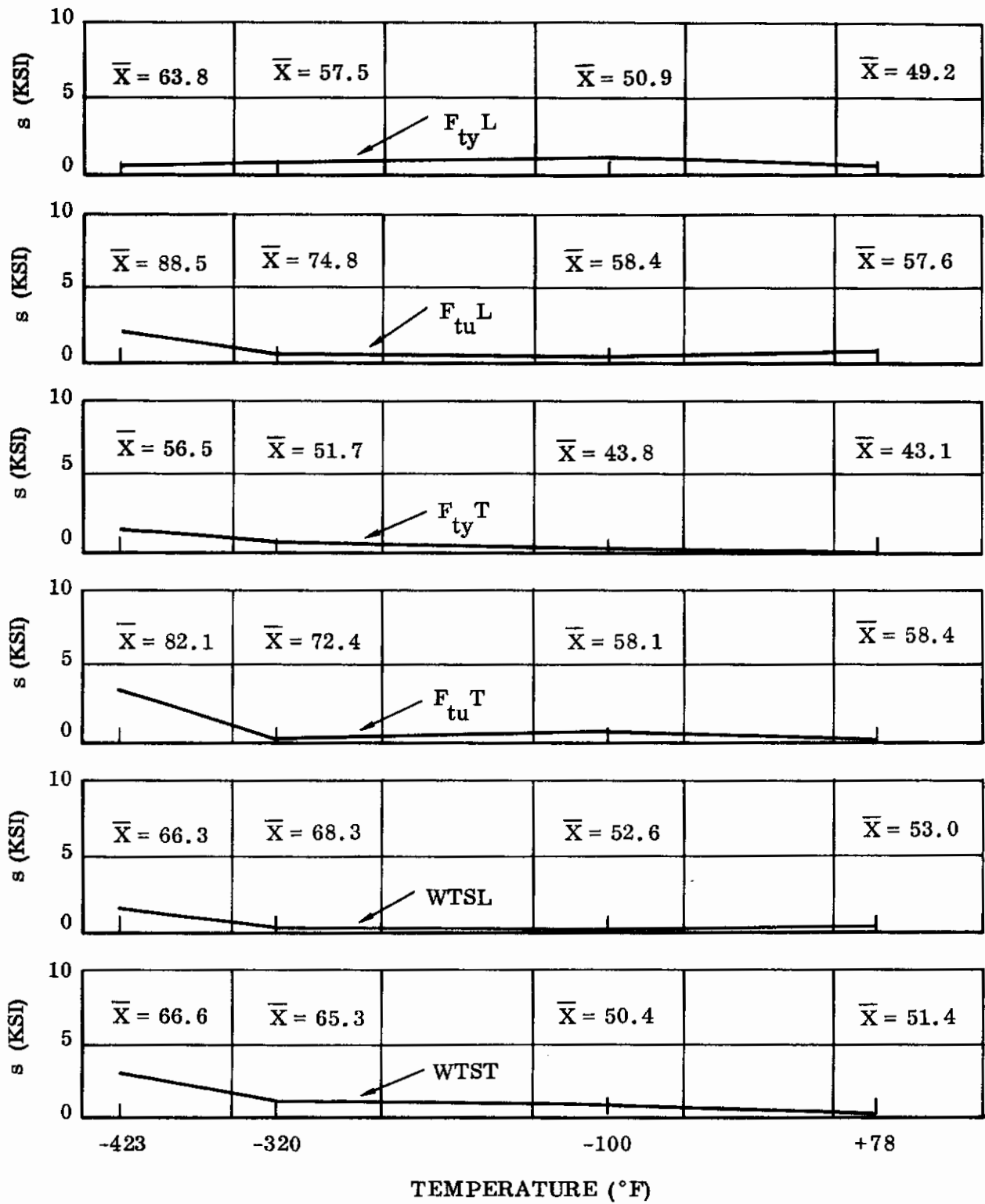

Figure 135. Standard Deviations Versus Temperature (5454-H343 Aluminum Alloy)

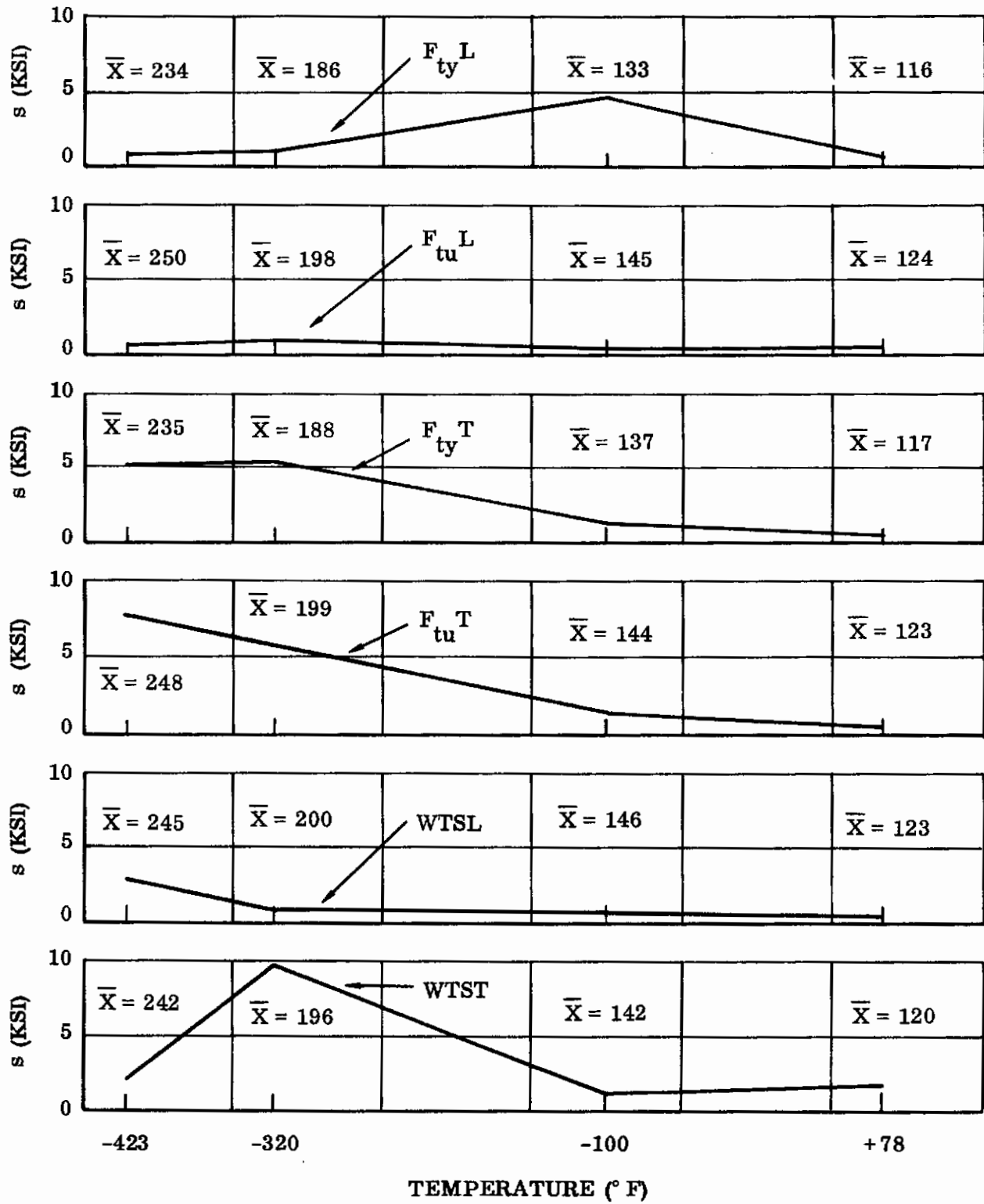

Figure 136. Standard Deviations Versus Temperature (Ti-5Al-2.5Sn Alloy)

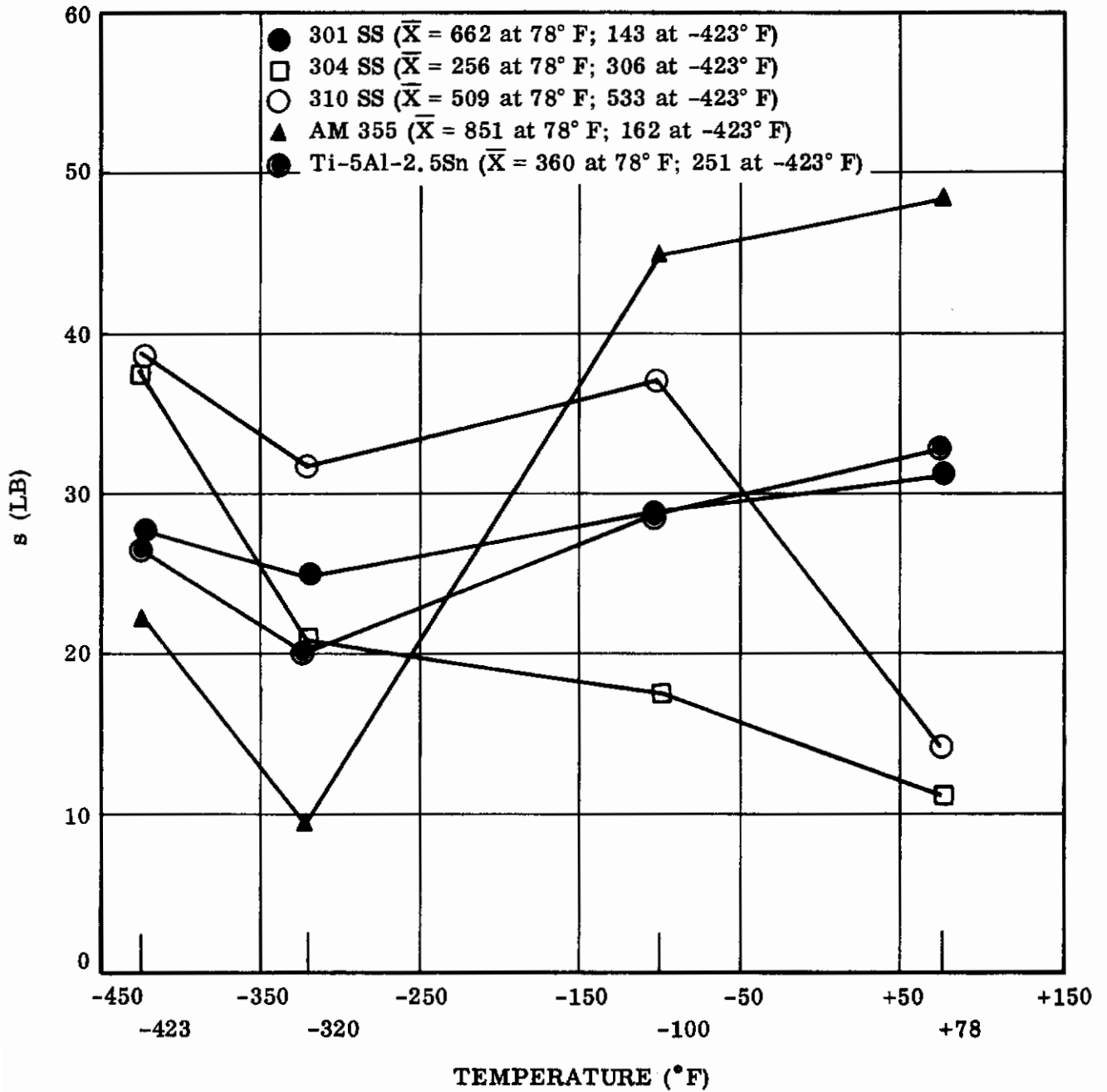

Figure 137. Standard Deviations Versus Temperature (Resistance Spot Welds - Tension)

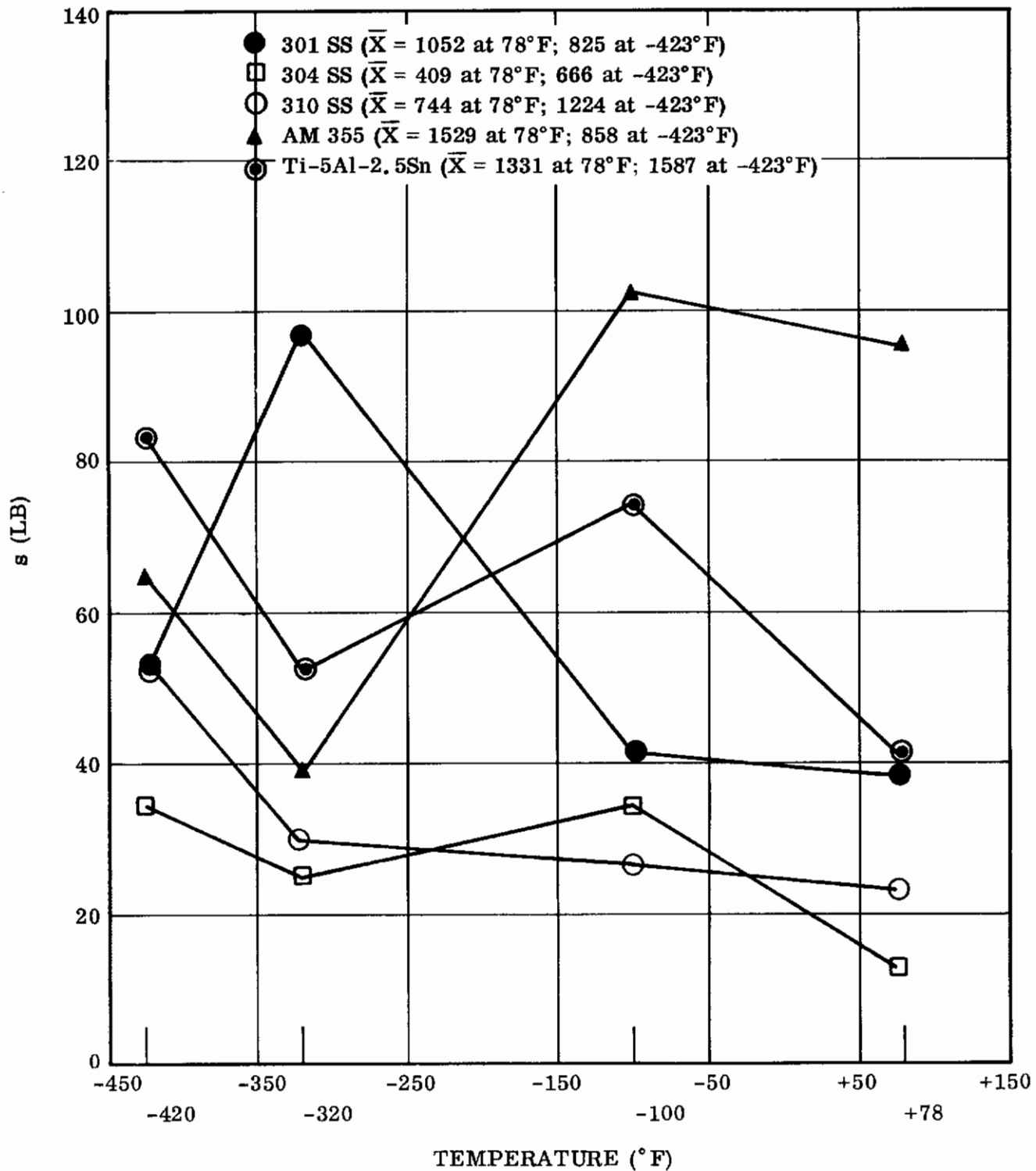

Figure 138. Standard Deviations Versus Temperature (Resistance Spot Welds - Shear)

TABLES

Contrails

Table 1. History and Chemical Analysis of Materials

| ALLOY | 301 SS | 304 ELC SS | 310 SS | AM-355 SS | 2014 Al Alloy | 5052 Al Alloy | 5456 Al Alloy | Ti-5Al- 2.5Sn |
|---------------------|---------------------|------------------|---------------------|----------------------|------------------|------------------|------------------|------------------|
| TEMPER | 60%CR | 50%CR | 75%CR | CRT | -T6 | -H38 | -H343 | Annealed |
| GAUGE (IN.) | 0.025 | 0.012 | 0.020 | 0.032 | 0.063 | 0.063 | 0.063 | 0.032 |
| SUPPLIER | Washington Steel | Rodney Metals | Washington Steel | Wallingford Steel | Alcoa | Alcoa | Alcoa | TMCA |
| HEAT NO. | 49061 | 33251 | 43631 | 38174 | | | | M-8394 |
| COIL NO. | 7450 | 44942 | | | | | | |
| SPECIFICATION | GD/A-O- 71004 | | GD/A-O- 71004 | | AMS- 4029 | QQ-A- 318 | Mil-A- 19842 | Internal |
| HARDNESS (15-N) | 83.9 | 76.8 | 79.3 | 86.6 | 58.7 | 40.9 | 49.2 | 77.5 |
| MARTENSITE (%) | 76 | 0 | 0 | 95 | - | - | - | - |
| CHEMISTRY (WT.%) | | | | | | | | |
| Al | - | - | - | - | Bal | Bal | Bal | 5.6 |
| C | 0.07 | 0.023 | 0.060 | 0.14 | - | - | - | 0.015 |
| Cr | 17.28 | 18.04 | 24.62 | 15.60 | 0.01 | 0.189 | 0.13 | - |
| Cu | - | - | 0.23 | - | 4.51 | 0.019 | 0.052 | - |
| Fe | Bal | Bal | Bal | Bal | 0.48 | 0.222 | 0.20 | 0.04 |
| H | - | - | - | - | - | - | - | 0.013 |
| Mg | - | - | - | - | 0.472 | 2.34 | 4.85 | - |
| Mn | 0.66 | 1.54 | 1.60 | 0.72 | 0.70 | 0.01 | 0.67 | - |
| Mo | - | - | 0.32 | 2.71 | - | - | - | - |
| N | 0.031 | - | - | 0.11 | - | - | - | 0.009 |
| Ni | 6.70 | 10.39 | 19.66 | 4.38 | - | - | - | - |
| O | - | - | - | - | - | - | - | 0.17 |
| P | 0.022 | 0.026 | 0.030 | 0.018 | - | - | - | - |
| S | 0.015 | 0.011 | 0.011 | 0.018 | - | - | - | - |
| Si | 0.63 | 0.66 | 0.58 | 0.29 | 1.03 | 0.083 | 0.080 | - |
| Sn | - | - | - | - | - | - | - | 2.2 |
| Ti | - | - | - | - | 0.041 | - | 0.023 | Bal |
| Zn | - | - | - | - | - | 0.01 | - | - |

Table 2. Inert-Arc Straight Line Fusion Weld Schedules

| MATERIAL | FILLER | AMPS | VOLTS | SPEED (IN/MIN) | BACKUP GAS (FT ³ /HR) | TORCH GAS (FT ³ /HR) | CLAMP PRES- SURE (psi) | BACKUP BAR (ROOM TEMP) | ELECTRODE (TUNGSTEN- 2% THORIATED) (in)** |
|------------------------------------|------------------|----------------|-------|-------------------|--|---------------------------------------|---------------------------------|---------------------------------|--|
| 301 SS 0.025 in. | None | 18 | 13* | 15 | A/15 | A/10:He/35 | 40 | Copper | 0.060 |
| 304 ELC SS 0.012 in. | None | 12 | 7* | 12.5 | A/15 | A/50 | 40 | Copper | 0.040 |
| 310 SS 0.020 in. | None | 15 | 14* | 15 | A/15 | A/10:He/45 | 40 | Copper | 0.040 |
| AM-355 SS 0.032 in. | None | 18 | 11* | 15 | A/15 | A/10:He/35 | 40 | Copper | 0.040 |
| Ti-5Al-2.5Sn Alloy 0.032 in. | None | 25 | 12* | 10 | He/15 | A/5:He/30 Trailing Shield He/20 | 40 | Copper | 0.040 |
| 2014-T6 Al Alloy 0.063 in. | 2319 Al Alloy | 175*** | - | 4 | None | A/12 | 40 | Al with Copper insert | 0.156 |
| 2014-T6 Al Alloy 0.125 in. | 2319 Al Alloy | 180*** | - | 6 | None | A/10 | 40 | Al with Copper insert | 0.125 |
| 5052-H38 Al Alloy 0.125 in. | 5356 Al Alloy | 210*** | - | 10 | None | A/12 | 40 | Al with Copper insert | 0.156 |
| 5456-H343 Al Alloy 0.063 in. | 5356 Al Alloy | 165- 170*** | - | 4 | None | A/12 | 40 | Al with Copper Insert | 0.156 |
| 5456-H343 Al Alloy 0.125 in. | 5356 Al Alloy | 165- 175*** | - | 10 | None | A/10 | 40 | Al with Copper insert | 0.125 |

* Direct current, straight polarity

** All electrodes tapered 30°

*** Alternating current, 60 cycle, single phase

Table 3. Resistance Spot Weld Schedules*

| ELECTRODE MATERIAL FORCE(LB) | IMPULSES | HEAT (CYCLES) | COOL (CYCLES) | SQUEEZE (CYCLES) | HOLD (CYCLES) | WELD (% HEAT) | ELECTRODES (TOP AND BOTTOM) CLASS FACE(IN.) | RADIUS (IN.) |
|--|----------|------------------|------------------|---------------------|------------------|------------------|--|--------------|
| 301 SS 0.025 in.- 0.025 in. | 2 | 2 | 2 | 30 | 30 | 68 | III | 1/4 |
| 304 SS 0.012 in.- 0.012 in. | 2 | 2 | 2 | 30 | 30 | 54 | III | 1/4 |
| 310 SS 0.020 in.- 0.020 in. | 2 | 2 | 2 | 30 | 30 | 62 | III | 1/4 |
| AM-355 SS 0.032 in.- 0.032 in. | 2 | 3 | 2 | 30 | 30 | 67 | III | 3/8 |
| Ti-5Al- 2.5Sn Alloy 0.032 in.- 0.032 | 2 | 3 | 2 | 30 | 30 | 72 | III | 3/8 |

*Thomson Tri Mono Phase welder, General Electric panel, 90 KVA Transformer.

Table 4. Resistance Seam Weld Schedules*

| MATERIAL | ELECTRODE FORCE (LB) | HEAT (CYCLES) | COOL (CYCLES) | WELD HEAT (%HEAT) | SPEED (IN/MIN) | CLASS | ELECTRODES (TOP AND BOTTOM) | | | |
|---|-------------------------|------------------|------------------|----------------------|-------------------|-------|-----------------------------|----------------|-------------------|----|
| | | | | | | | FACE DIAMETER (IN) | RADIUS (IN) | SPOTS PER INCH | |
| 301 SS 0.025 in. -0.025 in. | 1000 | 2 | 6 | 80 | 20 | III | 3/8 | 10 | 4 | 15 |
| 304 SS 0.012 in. -0.012 in. | 600 | 1 | 6 | 78 | 20 | III | 3/8 | 10 | 4 | 20 |
| 310 SS 0.020 in. -0.020 in. | 900 | 2 | 6 | 56 | 20 | III | 3/8 | 10 | 4 | 18 |
| AM-355 SS 0.032 in. -0.032 in. | 1200 | 3 | 7 | 66 | 16 | III | 1/2 | 10 | 6 | 14 |
| Ti-5Al-2.5Sn Alloy 0.032 in. -0.032 in. | 1200 | 3 | 7 | 68 | 16 | III | 1/2 | 10 | 6 | 13 |

*Thomson Tri Mono Phase welder, General Electric panel, 125 KVA Transformer

Table 5. Properties of 60 Percent Cold Rolled 301 Stainless Steel (0.025 In. Sheet, Washington Steel, Heat No. 49061, Coil No. 7450)

| TEST TEMP (of) | DIR | F _{ty} (KSI) | F _{tu} (KSI) | ELONG (%) | PROPORTIONAL LIMIT (KSI) | ELASTIC MODULUS (PSI X 10 ⁶) | HARDNESS (15-N) | | % MARTENSITE | |
|----------------|--------|-----------------------|-----------------------|-----------|--------------------------|--|-------------------|----------------|-----------------|----------------|
| | | | | | | | REDUCTION SECTION | FRACTURED EDGE | REDUCED SECTION | FRACTURED EDGE |
| 78 | Long. | 200 | 223 | 10.5 | 101 | 25.3 | 85.4 | 84.9 | 97 | 97 |
| | Long. | 205 | 225 | 10.5 | 72.3 | 24.4 | 85.9 | 85.3 | 96 | 97 |
| | Long. | 198 | 222 | 11.5 | 90.0 | 24.7 | 86.0 | 86.0 | 96 | 97 |
| | Long. | 200 | 224 | 10.5 | 80.3 | 25.3 | 85.4 | 85.0 | 96 | 97 |
| | Long. | 197 | 224 | 11.0 | 76.0 | 27.0 | 86.2 | 86.1 | 96 | 97 |
| | AVG | 200 | 224 | 10.8 | 83.9 | 25.3 | 85.8 | 85.5 | 96 | 97 |
| 78 | Trans. | 178 | 239 | 7.5 | 88.2 | 28.4 | 86.8 | 86.0 | 95 | 96 |
| | Trans. | 174 | 236 | 7.5 | 101 | 26.3 | 86.2 | 87.0 | 97 | 97 |
| | Trans. | 175 | 239 | 7.5 | 89.9 | 27.8 | 84.9 | 85.9 | 97 | 97 |
| | Trans. | 176 | 240 | 7.5 | 91.9 | 27.4 | 87.2 | 85.5 | 96 | 97 |
| | Trans. | 178 | 241 | 7.5 | 100 | 26.2 | 86.8 | 86.0 | 97 | 97 |
| | AVG | 176 | 239 | 7.5 | 94.2 | 27.2 | 86.4 | 86.1 | 96 | 97 |
| -100 | Long. | 237 | 252 | 14.5 | 144 | 28.3 | 88.7 | 87.1 | 99 | 99 |
| | Long. | 240 | 252 | 14.0 | 101 | 26.4 | 85.9 | 85.9 | 99 | 99 |
| | Long. | 232 | 254 | 15.0 | 101 | 26.1 | 89.1 | 92.3 | 99 | 99 |
| | Long. | 238 | 253 | 15.0 | 138 | 29.7 | 88.8 | 91.8 | 99 | 99 |
| | Long. | 236 | 253 | 15.0 | 100 | 26.8 | 89.8 | 88.8 | 99 | 99 |
| | AVG | 237 | 253 | 14.7 | 117 | 27.5 | 88.5 | 89.2 | 99 | 99 |
| -100 | Trans. | 200 | 267 | 11.5 | 122 | 30.0 | 86.4 | 84.8 | 99 | 99 |
| | Trans. | 199 | 265 | 11.5 | 113 | 30.2 | 88.0 | 88.0 | 99 | 99 |
| | Trans. | 191 | 268 | 11.0 | 100 | 30.4 | 86.5 | 86.5 | 99 | 98 |
| | Trans. | 199 | 268 | 12.0 | 103 | 28.0 | 89.5 | 86.6 | 99 | 99 |
| | Trans. | 195 | 266 | 11.5 | 126 | 29.0 | 86.6 | 85.8 | 99 | 98 |
| | AVG | 197 | 267 | 11.5 | 113 | 29.5 | 87.4 | 86.4 | 99 | 99 |



| | | | | | | | | | | |
|------|--------|-----|-----|------|-----|------|------|------|-----|-----|
| -320 | Long. | 262 | 323 | 20.0 | 140 | 31.9 | 89.9 | 87.1 | 99 | 98 |
| | Long. | - | 324 | 19.5 | - | - | 87.0 | 86.7 | 99 | 99 |
| | Long. | 249 | 321 | 19.0 | 142 | 27.3 | 90.2 | 88.8 | 99 | 99 |
| | Long. | 256 | 322 | 19.0 | 168 | 29.2 | 89.5 | 87.0 | 99 | 98 |
| | Long. | 285 | 322 | 19.5 | 161 | 25.8 | 91.1 | 90.0 | 100 | 99 |
| | Long. | - | 323 | 20.5 | - | - | 88.8 | 88.2 | 99 | 100 |
| | Long. | 244 | 324 | 19.0 | 141 | 27.8 | 89.0 | 87.1 | 99 | 99 |
| | AVG | 254 | 323 | 19.5 | 146 | 28.4 | 89.4 | 87.8 | 99 | 99 |
| -320 | Trans. | 236 | 326 | 16.5 | 130 | 29.7 | 89.4 | 90.9 | 99 | 98 |
| | Trans. | 233 | 327 | 16.5 | 143 | 31.4 | 88.4 | 88.6 | 99 | 98 |
| | Trans. | 234 | 325 | 17.0 | 144 | 28.4 | 89.9 | 87.3 | 99 | 98 |
| | Trans. | 238 | 327 | 16.5 | 148 | 33.0 | 88.5 | 89.1 | 99 | 99 |
| | Trans. | 234 | 327 | 14.0 | 129 | 27.6 | 89.2 | 90.2 | 99 | 98 |
| | AVG | 235 | 326 | 16.1 | 139 | 30.0 | 89.1 | 89.2 | 99 | 98 |
| -423 | Long. | 312 | 333 | 2.0 | 161 | 30.3 | 84.3 | 85.6 | 78 | 97 |
| | Long. | 305 | 335 | 1.5 | 171 | 31.9 | 84.8 | 83.5 | 78 | 97 |
| | Long. | 304 | 344 | 3.5 | 163 | 28.7 | 82.5 | 84.0 | 78 | 96 |
| | Long. | 313 | 336 | 8.0 | 182 | 29.1 | 82.9 | 86.0 | 82 | 98 |
| | Long. | 308 | 328 | 2.5 | - | - | 84.2 | 86.2 | 78 | 97 |
| | AVG | 308 | 335 | 3.5 | 169 | 30.0 | 83.6 | 85.1 | 79 | 97 |
| -423 | Trans. | 313 | 342 | 7.0 | 171 | 28.4 | 87.0 | 87.0 | 94 | 97 |
| | Trans. | 312 | 349 | 5.0 | 164 | 29.4 | 85.6 | 86.8 | 96 | 98 |
| | Trans. | 308 | 354 | 3.0 | 149 | 33.9 | 87.3 | 88.1 | 94 | 95 |
| | Trans. | 293 | 342 | 2.5 | 174 | 33.6 | 86.8 | 85.5 | 94 | 95 |
| | Trans. | 287 | 341 | 5.5 | 177 | 29.3 | 88.2 | 87.8 | 96 | 97 |
| | AVG | 303 | 346 | 4.6 | 167 | 30.9 | 87.0 | 87.0 | 95 | 96 |



Table 5 (Cont)

| TEST TEMP (°F) | DIR | NOTCH T.S. (K _t =3.2) (KSI) | FRACTURE TOUGHNESS, K (PSI √IN.) | NOTCH/ UNNOTCH TENSILE RATIO | NOTCH T.S. (K _t =6.3) (KSI) | FRACTURE TOUGHNESS, K (PSI √IN.) | NOTCH/ UNNOTCH TENSILE RATIO |
|----------------|--------|--|----------------------------------|------------------------------|--|----------------------------------|------------------------------|
| 78 | Long. | 241 (3.2) | 67.4 | | 241 (6.8) | 67.4 | |
| | Long. | 246 (3.2) | 69.0 | | 238 (6.7) | 66.8 | |
| | Long. | 247 (3.2) | 69.1 | | 241 (6.7) | 67.6 | |
| | Long. | 248 (3.2) | 69.3 | | 241 (6.7) | 67.4 | |
| | Long. | 247 (3.2) | 69.2 | | 238 (6.7) | 66.8 | |
| | AVG | 246 | 68.8 | 1.10 | 240 | 67.2 | 1.07 |
| 78 | Trans. | 240 (3.2) | 67.1 | | 203 (6.5) | 51.7 | |
| | Trans. | 242 (3.2) | 67.8 | | 200 (6.4) | 53.6 | |
| | Trans. | 228 (3.1) | 63.9 | | 192 (6.4) | 56.1 | |
| | Trans. | 228 (3.2) | 63.8 | | 210 (6.4) | 59.9 | |
| | Trans. | 232 (3.2) | 65.0 | | 200 (6.4) | 55.9 | |
| | AVG | 234 | 65.5 | 0.98 | 201 | 55.4 | 0.84 |
| -100 | Long. | 248 (3.2) | 69.3 | | 248 (6.7) | 69.4 | |
| | Long. | 270 (3.2) | 75.6 | | 248 (6.7) | 69.3 | |
| | Long. | 270 (3.2) | 75.7 | | 249 (6.6) | 69.7 | |
| | Long. | 269 (3.2) | 75.3 | | 248 (6.6) | 69.5 | |
| | Long. | 268 (3.2) | 75.1 | | 249 (6.6) | 69.8 | |
| | AVG | 265 | 74.2 | 1.05 | 248 | 69.5 | 0.98 |
| -100 | Trans. | 256 (3.2) | 71.6 | | 213 (6.4) | 59.5 | |
| | Trans. | 263 (3.2) | 73.6 | | 213 (6.4) | 59.7 | |
| | Trans. | 258 (3.2) | 72.2 | | 206 (6.4) | 57.8 | |
| | Trans. | 261 (3.2) | 73.1 | | 214 (6.7) | 60.0 | |
| | Trans. | 260 (3.2) | 72.7 | | 217 (6.7) | 60.9 | |
| | AVG | 260 | 72.6 | 0.97 | 213 | 59.6 | 0.80 |

| | | | | | | | |
|------|--------|------------|-------------|------|------------|-------------|------|
| -320 | Long. | 321 (3.2) | 89.8 | | 302 (6.6) | 84.6 | |
| | Long. | 313 (3.2) | 87.7 | | 295 (6.6) | 82.6 | |
| | Long. | 308 (3.2) | 86.2 | | 299 (6.6) | 83.6 | |
| | Long. | 319 (3.2) | 89.5 | | 295 (6.6) | 82.5 | |
| | Long. | 325 (3.2) | 91.1 | | 299 (6.6) | 83.8 | |
| | AVG | <u>317</u> | <u>88.9</u> | 0.98 | <u>298</u> | <u>83.4</u> | 0.92 |
| -320 | Trans. | 325 (3.2) | 90.9 | | 226 (6.7) | 63.2 | |
| | Trans. | 311 (3.2) | 86.9 | | 223 (6.7) | 62.4 | |
| | Trans. | 308 (3.2) | 86.1 | | 218 (6.7) | 61.0 | |
| | Trans. | 314 (3.2) | 88.0 | | 222 (6.7) | 62.1 | |
| | Trans. | 313 (3.2) | 87.8 | | 212 (6.7) | 59.3 | |
| | AVG | <u>314</u> | <u>87.9</u> | 0.96 | <u>220</u> | <u>61.6</u> | 0.67 |
| -423 | Long. | 375 (3.2) | 105 | | 306 (6.6) | 85.7 | |
| | Long. | 353 (3.2) | 99.0 | | 310 (6.6) | 86.8 | |
| | Long. | 376 (3.2) | 105 | | 292 (6.6) | 81.8 | |
| | Long. | 386 (3.2) | 108 | | 299 (6.6) | 83.8 | |
| | Long. | 378 (3.2) | 106 | | 303 (6.6) | 84.9 | |
| | AVG | <u>374</u> | <u>103</u> | 1.11 | <u>302</u> | <u>84.6</u> | 0.90 |
| -423 | Trans. | 296 (3.2) | 82.9 | | 228 (6.7) | 63.9 | |
| | Trans. | 299 (3.2) | 83.7 | | 214 (6.7) | 59.8 | |
| | Trans. | 324 (3.2) | 90.9 | | 205 (6.7) | 57.3 | |
| | Trans. | 306 (3.2) | 85.7 | | 214 (6.7) | 59.9 | |
| | Trans. | 311 (3.2) | 87.2 | | 236 (6.7) | 66.2 | |
| | AVG | <u>307</u> | <u>86.1</u> | 0.89 | <u>219</u> | <u>61.4</u> | 0.63 |



Table 5 (Cont)

| TEST TEMP (°F) DIR | NOTCH T.S. (K _t =19) (KSI) | FRACTURE TOUGHNESS K (PSI√IN) | NOTCH/ UNNOTCH TENSILE RATIO | WELD T.S. (KSI) | WELD ELONG (%) | JOINT EFF (%) | HARDNESS (15-N) | | % MARTENSITE | |
|--------------------------|---|-------------------------------------|---------------------------------------|--------------------|----------------------|---------------------|--------------------------|------|--------------------------|------|
| | | | | | | | HEAT AFFECTED ZONE | WELD | HEAT AFFECTED ZONE | WELD |
| 78 Long. | 210 (24.1) | 102 | 0.94 | 170 | 2.5 | | 83.1 | 80.9 | 75 | 98 |
| 78 Long. | 208 (24.1) | 101 | | 176 | 3.0 | | 83.1 | 82.3 | 75 | 98 |
| 78 Long. | 214 (22.4) | 103 | | 179 | 3.0 | | 82.8 | 81.8 | 77 | 97 |
| 78 Long. | 207 (24.1) | 100 | | 175 | 2.5 | | 83.0 | 82.7 | 76 | 97 |
| 78 Long. | 211 (24.1) | 102 | | 176 | 3.0 | | 82.0 | 83.2 | 78 | 96 |
| 78 Avg | 210 | 102 | 0.94 | 175 | 2.8 | 78 | 82.8 | 82.2 | 76 | 97 |
| 78 Trans. | 138 (26.4) | 66.5 | | 171 | 2.0 | | 84.2 | 84.6 | 78 | 98 |
| 78 Trans. | 148 (26.4) | 71.5 | | 172 | 2.5 | | 84.2 | 83.1 | 81 | 99 |
| 78 Trans. | 157 (22.3) | 76.0 | | 172 | 2.0 | | 83.6 | 80.2 | 75 | 100 |
| 78 Trans. | 153 (26.4) | 73.9 | | 179 | 2.5 | | 83.8 | 83.9 | 78 | 99 |
| 78 Trans. | 165 (26.4) | 79.8 | | 175 | 2.0 | | 83.5 | 84.2 | 78 | 99 |
| 78 Avg | 152 | 73.5 | 0.64 | 174 | 2.2 | 73 | 83.9 | 83.2 | 78 | 99 |
| -100 Long. | 219 (24.1) | 106 | | 219 | 6.0 | | 85.7 | 81.2 | 96 | 99 |
| -100 Long. | 219 (22.4) | 106 | | 213 | 6.0 | | 86.5 | 83.0 | 96 | 99 |
| -100 Long. | 217 (22.4) | 105 | | 218 | 5.0 | | 86.0 | 84.1 | 97 | 99 |
| -100 Long. | 198 (22.4) | 95.9 | | 213 | 5.0 | | 85.5 | 85.6 | 96 | 99 |
| -100 Long. | 184 (22.4) | 88.9 | | 218 | 6.0 | | 87.0 | 84.0 | 97 | 98 |
| -100 Avg | 207 | 100 | 0.82 | 216 | 5.6 | 85 | 86.1 | 83.6 | 96 | 99 |
| -100 Trans. | 147 (26.4) | 71.2 | | 214 | 4.0 | | 86.3 | 85.0 | 96 | 99 |
| -100 Trans. | 146 (26.4) | 70.7 | | 212 | 2.5 | | 85.5 | 83.2 | 96 | 98 |
| -100 Trans. | 140 (26.4) | 67.7 | | 210 | 2.0 | | 85.6 | 83.5 | 96 | 98 |
| -100 Trans. | 159 (22.3) | 76.7 | | 213 | 3.0 | | 86.0 | 82.0 | 95 | 98 |
| -100 Trans. | 134 (22.3) | 64.9 | | 212 | 2.5 | | 86.5 | 81.2 | 95 | 99 |
| -100 Avg | 145 | 70.2 | 0.54 | 212 | 2.8 | 79 | 86.0 | 83.0 | 96 | 98 |



| | | | | | | | | |
|-------------|------------|------|-----|------|------|------|------|----|
| -320 Long. | 220 (22.4) | 106 | 300 | 12.5 | 92 | 87.3 | 82.1 | 98 |
| Long. | 203 (22.4) | 97.9 | 301 | 10.0 | | 87.0 | 86.2 | 98 |
| Long. | 227 (22.4) | 109 | 300 | 12.5 | | 87.5 | 86.7 | 98 |
| Long. | 192 (22.3) | 92.9 | 296 | 12.5 | | 86.8 | 87.0 | 98 |
| Long. | 209 (22.4) | 101 | 295 | 12.5 | | 86.0 | 87.1 | 99 |
| Avg | 206 | 101 | 298 | 12.0 | 0.64 | 86.9 | 85.8 | 98 |
| -320 Trans. | 132 (26.4) | 63.5 | 293 | 7.5 | | 88.9 | 84.5 | 99 |
| Trans. | 170 (24.1) | 82.0 | 287 | 4.0 | | 87.6 | 89.1 | 99 |
| Trans. | 154 (26.4) | 74.5 | 292 | 5.0 | | 88.8 | 90.0 | 99 |
| Trans. | 120 (26.4) | 57.9 | 291 | 5.0 | | 86.0 | 85.5 | 98 |
| Trans. | 110 (22.3) | 53.2 | 290 | 5.0 | | 87.2 | 82.2 | 98 |
| Avg | 137 | 66.2 | 291 | 5.3 | 0.42 | 87.7 | 86.3 | 99 |
| -423 Long. | 207 (22.4) | 99.8 | 216 | 1.0 | | 84.1 | 85.4 | 97 |
| Long. | 225 (22.3) | 109 | 226 | 1.0 | | 84.5 | 85.0 | 97 |
| Long. | 218 (24.1) | 105 | 208 | 1.0 | | 84.5 | 86.0 | 97 |
| Long. | 201 (22.4) | 97.1 | 181 | 1.0 | | 84.9 | 84.0 | 97 |
| Long. | 217 (22.4) | 100 | 177 | 1.0 | | 83.5 | 84.5 | 97 |
| Avg | 212 | 102 | 202 | 1.0 | 0.61 | 84.3 | 85.0 | 97 |
| -423 Trans. | 131 (22.3) | 63.2 | 187 | 1.0 | | 83.1 | 85.1 | 97 |
| Trans. | 147 (26.4) | 70.9 | 209 | 1.5 | | 83.8 | 84.6 | 97 |
| Trans. | 136 (26.4) | 65.9 | 171 | 1.5 | | 85.2 | 84.5 | 97 |
| Trans. | 156 (22.3) | 75.6 | 205 | 1.5 | | 84.1 | 85.3 | 97 |
| Trans. | 140 (26.4) | 67.8 | 249 | 1.0 | | 84.0 | 86.1 | 97 |
| Avg | 142 | 68.7 | 204 | 1.3 | 0.41 | 84.0 | 85.1 | 97 |

Table 6. Properties of 50 Percent Cold Rolled 304 ELC Stainless Steel (0.012 In. Sheet, Rodney Metals, Heat No. 33251)

| TEST TEMP (°F) | DIR | F _{ty} (KSI) | F _{tu} (KSI) | ELONG PROPORTIONAL (%) | LIMIT (KSI) | ELASTIC MODULUS ⁶ (PSI x 10 ⁶) | HARDNESS (15-N) | | % MARTENSITE | |
|-------------------|--------|--------------------------|--------------------------|---------------------------|-------------|---|-----------------|----------------|-----------------|----------------|
| | | | | | | | REDUCED SECTION | FRACTURED EDGE | REDUCED SECTION | FRACTURED EDGE |
| 78 | Long. | 164 | 181 | 2.5 | 59.4 | 25.8 | 76.6 | 76.8 | 2 | 3 |
| | Long. | 153 | 179 | 2.5 | 37.9 | 25.0 | 76.4 | 77.6 | 1 | 1 |
| | Long. | 157 | 179 | 2.5 | 39.7 | 25.3 | 76.3 | 77.5 | 1 | 2 |
| | Long. | 159 | 180 | 2.5 | 42.4 | 25.6 | 76.8 | 76.8 | 1 | 1 |
| | Long. | 158 | 181 | 2.5 | 42.4 | 25.9 | 76.3 | 77.4 | 1 | 2 |
| | AVG | 158 | 180 | 2.5 | 44.4 | 25.5 | 76.5 | 77.2 | 1 | 2 |
| 78 | Trans. | 150 | 194 | 5.0 | 42.4 | 30.3 | 77.0 | 78.2 | 1 | 2 |
| | Trans. | 153 | 194 | 5.0 | 46.7 | 29.7 | 76.8 | 76.8 | 1 | 1 |
| | Trans. | 154 | 194 | 5.0 | 47.3 | 28.5 | 77.2 | 78.0 | 0 | 1 |
| | Trans. | 150 | 194 | 5.0 | 46.7 | 30.3 | 77.8 | 77.8 | 1 | 1 |
| | Trans. | 150 | 194 | 5.0 | 42.4 | 30.0 | 77.2 | 77.0 | 1 | 1 |
| | AVG | 151 | 194 | 5.0 | 45.1 | 29.8 | 77.2 | 77.6 | 1 | 1 |
| -100 | Long. | 177 | 199 | 4.0 | 97.6 | 26.0 | 76.7 | 76.0 | 1 | 1 |
| | Long. | 179 | 201 | 3.5 | 83.1 | 26.2 | 76.9 | 76.4 | 2 | 4 |
| | Long. | 182 | 201 | 5.0 | 98.8 | 26.2 | 77.3 | 76.9 | 2 | 4 |
| | Long. | 183 | 200 | 5.0 | 91.6 | 27.7 | 77.0 | 78.0 | 1 | 2 |
| | Long. | 175 | 199 | 5.0 | 90.0 | 27.2 | 77.2 | 77.9 | 2 | 2 |
| | AVG | 179 | 200 | 4.5 | 92.2 | 26.7 | 77.0 | 77.0 | 2 | 3 |
| -100 | Trans. | 177 | 219 | 5.5 | 83.3 | 29.5 | 76.8 | 78.4 | 1 | 1 |
| | Trans. | 175 | 219 | 5.5 | 87.4 | 29.1 | 76.5 | 78.0 | 2 | 2 |
| | Trans. | 178 | 219 | 7.0 | 89.1 | 30.8 | 76.7 | 79.0 | 1 | 2 |
| | Trans. | 164 | 217 | 6.0 | 75.5 | 29.8 | 76.5 | 78.3 | 1 | 1 |
| | Trans. | 175 | 217 | 2.0 | 81.8 | 30.7 | 77.0 | 77.2 | 2 | 3 |
| | AVG | 174 | 218 | 5.2 | 83.4 | 30.0 | 76.7 | 78.2 | 1 | 2 |

| | | | | | | | | | |
|-------------|-----|-----|------|------|------|------|------|---|----|
| -320 Long. | 190 | 235 | 25.0 | 91.3 | 25.7 | 76.8 | 79.9 | 1 | 97 |
| Long. | 205 | 238 | 24.0 | 94.9 | 27.8 | 76.8 | 81.8 | 3 | 96 |
| Long. | 189 | 253 | 30.0 | 94.9 | 27.4 | 82.2 | 82.1 | 1 | 97 |
| Long. | 189 | 252 | 31.0 | 100 | 27.4 | 82.6 | 82.0 | 1 | 97 |
| Long. | 204 | 234 | 22.5 | 100 | 27.1 | 83.0 | 80.0 | 2 | 97 |
| Avg | 195 | 242 | 26.5 | 96.2 | 27.1 | 80.3 | 81.2 | 2 | 97 |
| -320 Trans. | 197 | 249 | 33.0 | 91.3 | 30.5 | 82.6 | 81.7 | 1 | 96 |
| Trans. | 201 | 256 | 36.5 | 97.3 | 28.7 | 79.0 | 82.7 | 1 | 97 |
| Trans. | 204 | 257 | 25.0 | 101 | 31.1 | 82.1 | 81.2 | 1 | 96 |
| Trans. | 199 | 256 | 25.0 | 91.8 | 28.9 | 77.0 | 80.6 | 2 | 96 |
| Trans. | 205 | 256 | 34.5 | 102 | 29.4 | 82.1 | 81.9 | 1 | 97 |
| Avg | 201 | 255 | 30.8 | 96.7 | 29.9 | 80.6 | 81.6 | 1 | 96 |
| -423 Long. | 241 | 271 | 1.5 | 161 | 28.0 | 78.0 | 75.0 | 2 | 4 |
| Long. | 231 | 271 | 2.0 | 152 | 27.6 | 75.9 | 76.3 | 1 | 2 |
| Long. | 243 | 276 | 1.0 | 165 | 26.3 | 76.5 | 80.0 | 1 | 2 |
| Long. | 222 | 276 | 1.5 | 152 | 27.7 | 76.5 | 76.0 | 2 | 2 |
| Long. | 231 | 280 | 1.5 | 156 | 28.4 | 76.6 | 76.8 | 1 | 1 |
| Avg | 234 | 275 | 1.5 | 157 | 27.6 | 76.7 | 76.8 | 1 | 2 |
| -423 Trans. | 210 | 293 | 1.5 | --- | 31.9 | 76.5 | 75.4 | 1 | 1 |
| Trans. | 211 | 301 | 2.0 | 156 | 28.4 | 76.5 | 77.8 | 1 | 2 |
| Trans. | 228 | 289 | 2.5 | 152 | 28.3 | 76.5 | 76.8 | 2 | 2 |
| Trans. | 227 | 292 | 1.5 | 143 | 28.9 | 77.0 | 76.7 | 1 | 2 |
| Trans. | --- | 289 | 1.5 | --- | --- | 76.6 | 76.9 | 2 | 3 |
| Trans. | 233 | 304 | 2.0 | 157 | 30.6 | 76.8 | 77.1 | 1 | 1 |
| Avg | 222 | 295 | 1.8 | 152 | 29.6 | 76.7 | 76.8 | 1 | 2 |

Table 6. (Cont)

| TEST TEMP (°F) | DIR | NOTCH T.S. (K _t =3.2) (KSI) | FRACTURE TOUGHNESS, K (PSI √IN.) | NOTCH/ UNNOTCH TENSILE RATIO | NOTCH T.S. (K _t =6.3) (KSI) | FRACTURE TOUGHNESS, NOTCH/ K (PSI √IN.) | NOTCH/ UNNOTCH TENSILE RATIO |
|----------------------|--------|--|-------------------------------------|---------------------------------------|--|--|---------------------------------------|
| 78 | Long. | 192 (3.2) | 53.8 | | 199 (7.1) | 55.8 | |
| | Long. | 191 (3.2) | 53.5 | | 201 (7.1) | 56.2 | |
| | Long. | 191 (3.2) | 53.5 | | 198 (7.1) | 55.6 | |
| | Long. | 190 (3.2) | 53.2 | | 201 (7.1) | 56.2 | |
| | Long. | 189 (3.2) | 52.9 | | 197 (7.1) | 55.2 | 1.11 |
| | AVG | 191 | 53.4 | 106 | 199 | 55.8 | |
| 78 | Trans. | 217 (3.2) | 60.8 | | 209 (7.1) | 53.9 | |
| | Trans. | 218 (3.2) | 61.0 | | 218 (7.1) | 61.1 | |
| | Trans. | 213 (3.2) | 59.6 | | 218 (7.1) | 61.1 | |
| | Trans. | 217 (3.2) | 60.8 | | 216 (7.1) | 60.5 | |
| | Trans. | 217 (3.2) | 60.8 | | 224 (7.1) | 62.8 | 1.12 |
| | AVG | 216 | 60.6 | 1.11 | 217 | 59.9 | |
| -100 | Long. | 214 (3.2) | 59.9 | | 216 (7.1) | 60.5 | |
| | Long. | 214 (3.2) | 59.9 | | 220 (7.1) | 61.6 | |
| | Long. | 216 (3.2) | 60.5 | | 221 (7.1) | 61.9 | |
| | Long. | 214 (3.2) | 59.9 | | 219 (7.1) | 61.3 | |
| | Long. | 214 (3.2) | 59.9 | | 217 (7.1) | 60.8 | 1.10 |
| | AVG | 214 | 60.0 | 1.07 | 219 | 61.3 | |
| -100 | Trans. | 254 (3.2) | 71.1 | | 243 (7.1) | 68.0 | |
| | Trans. | 240 (3.2) | 67.2 | | 239 (7.1) | 66.9 | |
| | Trans. | 249 (3.2) | 69.7 | | 236 (7.1) | 66.1 | |
| | Trans. | 253 (3.2) | 70.8 | | 242 (7.1) | 67.8 | |
| | Trans. | 253 (3.2) | 70.8 | | 246 (7.1) | 68.9 | 1.11 |
| | AVG | 250 | 69.9 | 1.15 | 241 | 67.5 | |

| | | | | | | |
|------|--------|-----------|------|-----------|------|------|
| -320 | Long. | 226 (3.2) | 74.5 | 277 (7.1) | 77.6 | |
| | Long. | 262 (3.2) | 73.4 | 266 (7.1) | 74.5 | |
| | Long. | 259 (3.2) | 72.5 | 264 (7.1) | 73.9 | |
| | Long. | 268 (3.2) | 75.0 | 263 (7.1) | 73.6 | |
| | Long. | 262 (3.2) | 73.4 | 263 (7.1) | 73.6 | 1.10 |
| | AVG | 263 | 73.8 | 267 | 74.8 | |
| -320 | Trans. | 310 (3.2) | 86.8 | 301 (7.1) | 84.3 | |
| | Trans. | 311 (3.2) | 87.0 | 297 (7.1) | 83.2 | |
| | Trans. | 310 (3.2) | 86.8 | 294 (7.1) | 82.3 | |
| | Trans. | 307 (3.2) | 86.0 | 304 (7.1) | 85.1 | |
| | Trans. | 308 (3.2) | 86.2 | 304 (7.1) | 85.1 | 1.18 |
| | AVG | 309 | 86.6 | 300 | 84.0 | |
| -423 | Long. | 304 (3.2) | 85.1 | 312 (7.1) | 87.4 | |
| | Long. | 309 (3.2) | 86.5 | 307 (7.1) | 86.0 | |
| | Long. | 306 (3.2) | 85.7 | 308 (7.1) | 86.2 | |
| | Long. | 338 (3.2) | 94.6 | 308 (7.1) | 86.2 | |
| | Long. | 307 (3.2) | 86.0 | 314 (7.1) | 87.9 | 1.13 |
| | AVG | 313 | 87.6 | 310 | 86.8 | |
| -423 | Trans. | 347 (3.2) | 97.2 | 322 (7.1) | 90.2 | |
| | Trans. | 355 (3.2) | 99.4 | 333 (7.1) | 93.2 | |
| | Trans. | 370 (3.2) | 104 | 337 (7.1) | 94.4 | |
| | Trans. | 371 (3.2) | 104 | 348 (7.1) | 97.4 | |
| | Trans. | 384 (3.2) | 108 | 331 (7.1) | 92.7 | 1.13 |
| | AVG | 365 | 103 | 334 | 93.5 | |

Table 6 (Cont)

| TEST TEMP (°F) | DIR | NOTCH T.S. (K _t =19) (KSI) | FRACTURE TOUGHNESS K (PSI√IN) | NOTCH/ UNNOTCH TENSILE RATIO | WELD T.S. (KSI) | WELD ELONG (%) | JOINT EFF (%) | HARDNESS(15-N) HEAT AFFECTED ZONE | % MARTENSITE HEAT AFFECTED ZONE | | |
|----------------------|--------|---|-------------------------------------|---------------------------------------|--------------------|----------------------|---------------------|--|--|---|---|
| 78 | Long. | 176 (18.8) | 85.0 | | 76.7 | 2.5 | | 77.0 | 57.1 | 1 | 1 |
| | Long. | 158 (18.8) | 76.3 | | 76.1 | 1.5 | | 76.5 | 52.2 | 1 | 1 |
| | Long. | 174 (18.8) | 84.0 | | 75.9 | 2.0 | | 76.5 | 55.7 | 1 | 2 |
| | Long. | 173 (18.8) | 83.6 | | 79.9 | 2.0 | | 77.1 | 52.5 | 1 | 2 |
| | Long. | 176 (18.8) | 85.0 | | 83.4 | 1.5 | | 76.8 | 60.4 | 2 | 2 |
| | AVG | 171 | 82.8 | 0.95 | 78.4 | 1.9 | 44 | 76.8 | 55.6 | 1 | 2 |
| 78 | Trans. | 142 (18.3) | 68.6 | | 74.4 | 2.0 | | 77.1 | 53.6 | 1 | 1 |
| | Trans. | 153 (18.3) | 73.9 | | 81.6 | 2.0 | | 76.5 | 47.5 | 1 | 2 |
| | Trans. | 151 (18.3) | 72.9 | | 78.7 | 2.0 | | 76.8 | 54.5 | 1 | 1 |
| | Trans. | 129 (18.3) | 62.3 | | 71.9 | 1.5 | | 76.1 | 45.5 | 0 | 1 |
| | Trans. | 152 (18.3) | 73.4 | | 80.0 | 2.0 | | 76.3 | 50.0 | 1 | 1 |
| | AVG | 145 | 70.2 | 0.75 | 77.3 | 1.9 | 40 | 76.6 | 50.2 | 1 | 1 |
| -100 | Long. | 199 (18.8) | 96.1 | | 141 | 3.0 | | 77.0 | 71.5 | 2 | 3 |
| | Long. | 202 (18.8) | 97.6 | | 149 | 2.5 | | 76.6 | 64.5 | 1 | 2 |
| | Long. | 197 (18.8) | 95.2 | | 144 | 1.5 | | 74.0 | 65.0 | 2 | 1 |
| | Long. | 190 (18.8) | 91.8 | | 145 | 2.5 | | 76.8 | 65.0 | 1 | 1 |
| | Long. | 183 (18.8) | 88.4 | | 139 | 2.5 | | 75.9 | 66.3 | 1 | 2 |
| | AVG | 194 | 93.8 | 0.97 | 144 | 2.4 | 72 | 76.1 | 66.5 | 1 | 2 |
| -100 | Trans. | 181 (18.3) | 87.4 | | 144 | 2.5 | | 76.7 | 59.8 | 2 | 1 |
| | Trans. | 196 (18.3) | 94.7 | | 144 | 3.0 | | 77.0 | 60.0 | 2 | 2 |
| | Trans. | 147 (18.3) | 71.0 | | 142 | 2.0 | | 76.0 | 59.3 | 2 | 2 |
| | Trans. | 189 (18.3) | 91.3 | | 134 | 2.5 | | 77.0 | 72.0 | 1 | 1 |
| | Trans. | 172 (18.3) | 83.1 | | 143 | 2.5 | | 76.4 | 63.1 | 2 | 2 |
| | AVG | 177 | 85.5 | 0.81 | 141 | 2.5 | 65 | 76.6 | 62.8 | 2 | 2 |

| | | | | | | | | | | | | |
|------|--------|-----|--------|------|-----|-----|------|------|------|---|---|---|
| -320 | Long. | 232 | (18.8) | 112 | 215 | 3.0 | | 76.7 | 70.4 | 1 | 1 | 1 |
| | Long. | 221 | (18.8) | 107 | 215 | 3.0 | | 75.0 | 74.2 | 1 | 1 | 2 |
| | Long. | 246 | (18.8) | 119 | 217 | 4.0 | | 77.7 | 68.9 | 2 | 2 | 2 |
| | Long. | 229 | (18.8) | 111 | 217 | 3.0 | | 75.2 | 76.0 | 2 | 2 | 2 |
| | Long. | 241 | (18.8) | 116 | 215 | 2.0 | | 75.5 | 71.4 | 1 | 1 | 1 |
| | Avg | 234 | | 113 | 216 | 3.0 | 0.96 | 76.0 | 72.2 | 1 | 1 | 2 |
| -320 | Trans. | 238 | (18.3) | 115 | 212 | 3.0 | | 77.1 | 76.1 | 1 | 1 | 2 |
| | Trans. | 219 | (18.3) | 106 | 219 | 3.0 | | 76.6 | 75.0 | 1 | 1 | 1 |
| | Trans. | 235 | (18.3) | 114 | 210 | 3.0 | | 78.2 | 75.0 | 1 | 1 | 1 |
| | Trans. | 233 | (18.3) | 113 | 220 | 3.0 | | 76.8 | 73.1 | 2 | 2 | 2 |
| | Trans. | 226 | (18.3) | 109 | 200 | 3.0 | | 76.2 | 66.7 | 0 | 1 | 1 |
| | Avg | 230 | | 111 | 212 | 3.0 | 0.90 | 77.0 | 73.2 | 1 | 1 | 1 |
| -423 | Long. | 252 | (18.8) | 122 | 248 | 3.0 | | 76.2 | 72.9 | 1 | 1 | 2 |
| | Long. | 229 | (18.8) | 111 | 248 | 3.0 | | 76.2 | 77.8 | 1 | 1 | 4 |
| | Long. | 236 | (18.8) | 114 | 249 | 3.5 | | 76.7 | 71.3 | 1 | 1 | 4 |
| | Long. | 238 | (18.8) | 115 | 249 | 3.0 | | 76.0 | 74.4 | 1 | 1 | 2 |
| | Long. | 244 | (18.8) | 118 | 256 | 3.0 | | 76.4 | 69.5 | 2 | 2 | 6 |
| | Avg | 240 | | 116 | 250 | 3.1 | 0.87 | 76.3 | 73.2 | 1 | 1 | 4 |
| -423 | Trans. | 220 | (18.3) | 106 | 261 | 2.0 | | 76.2 | 73.1 | 1 | 1 | 4 |
| | Trans. | 193 | (18.3) | 93.2 | 264 | 4.0 | | 77.1 | 72.4 | 1 | 1 | 4 |
| | Trans. | 204 | (18.3) | 98.5 | 275 | 3.5 | | 76.2 | 74.1 | 2 | 2 | 8 |
| | Trans. | 199 | (18.3) | 96.1 | 269 | 3.0 | | 76.0 | 70.7 | 1 | 1 | 2 |
| | Trans. | 211 | (18.3) | 102 | 275 | 4.0 | | 77.0 | 69.9 | 2 | 2 | 2 |
| | Avg | 205 | | 99.2 | 269 | 3.3 | 0.69 | 76.5 | 72.0 | 1 | 1 | 4 |

Table 7. Properties of 75-Percent Cold-Rolled 310 Stainless Steel (0.020 In. Sheet, Washington Steel, Heat No. 43631, Coil No. 44942)

| TEST TEMP (°F) | DIR | F _{ty} (KSI) | F _{tu} (KSI) | ELONG (%) | PROPORTIONAL LIMIT (KSI) | ELASTIC MODULUS (PSI X 10 ⁶) | HARDNESS (15-N) | | | % MARTENSITE | |
|-------------------|--------|--------------------------|--------------------------|--------------|-----------------------------|--|--------------------|-------------------|--------------------|-------------------|--|
| | | | | | | | REDUCED SECTION | FRACTURED EDGE | REDUCED SECTION | FRACTURED EDGE | |
| 78 | Long. | 152 | 179 | 2.5 | 45.3 | 25.3 | 78.4 | 79.7 | 0 | 0 | |
| | Long. | 155 | 180 | 2.5 | 41.1 | 26.8 | 78.1 | 79.8 | 0 | 0 | |
| | Long. | 155 | 180 | 2.5 | 40.9 | 25.0 | 78.9 | 78.2 | 0 | 0 | |
| | Long. | 160 | 180 | 2.5 | 66.5 | 23.5 | 78.7 | 78.7 | 0 | 0 | |
| | Long. | 160 | 181 | 2.5 | 41.4 | 26.2 | 78.5 | 79.1 | 0 | 0 | |
| | AVG | 156 | 180 | 2.5 | 47.0 | 25.4 | 78.5 | 79.1 | 0 | 0 | |
| 78 | Trans. | 160 | 201 | 3.0 | 53.2 | 29.4 | 79.6 | 79.6 | 0 | 0 | |
| | Trans. | 152 | 201 | 3.5 | - | - | 79.2 | 79.3 | 0 | 0 | |
| | Trans. | 153 | 202 | 4.0 | 63.7 | 28.8 | 79.1 | 79.8 | 0 | 0 | |
| | Trans. | 159 | 197 | 3.5 | 73.1 | 27.0 | 79.9 | 79.8 | 0 | 0 | |
| | Trans. | 163 | 199 | 3.0 | 78.9 | 27.2 | 79.6 | 79.7 | 0 | 0 | |
| | AVG | 157 | 200 | 3.4 | 67.2 | 28.1 | 79.5 | 79.6 | 0 | 0 | |
| -100 | Long. | 183 | 201 | 5.0 | 90.5 | 26.2 | 79.0 | 80.0 | 0 | 0 | |
| | Long. | 182 | 202 | 5.0 | 102 | 26.6 | 80.0 | 80.5 | 0 | 0 | |
| | Long. | 186 | 204 | 5.5 | 115 | 24.4 | 79.4 | 81.0 | 0 | 0 | |
| | Long. | 189 | 205 | 5.0 | 114 | 26.3 | 79.1 | 81.1 | 0 | 0 | |
| | Long. | 187 | 204 | 4.5 | 106 | 24.0 | 79.6 | 80.0 | 0 | 0 | |
| | AVG | 185 | 203 | 5.0 | 105 | 25.5 | 79.4 | 80.5 | 0 | 0 | |
| -100 | Trans. | 187 | 224 | 7.5 | 102 | 26.0 | 79.9 | 81.7 | 0 | 0 | |
| | Trans. | 176 | 224 | 7.0 | - | 28.4 | 79.8 | 81.0 | 0 | 0 | |
| | Trans. | 182 | 223 | 6.5 | 95.3 | 30.3 | 80.0 | 80.8 | 0 | 0 | |
| | Trans. | 189 | 223 | 7.5 | 97.8 | 26.9 | 80.3 | 82.0 | 0 | 0 | |
| | Trans. | 193 | 225 | 7.5 | 101 | 26.3 | 79.5 | 80.5 | 0 | 0 | |
| | AVG | 185 | 224 | 7.2 | 99.0 | 27.6 | 79.9 | 81.2 | 0 | 0 | |

| | | | | | | | | | |
|-------------|-----|-----|------|-----|------|------|------|---|---|
| -320 Long. | 223 | 254 | 9.5 | 129 | 26.0 | 80.0 | 82.0 | 0 | 0 |
| Long. | 227 | 253 | 8.0 | 147 | 25.5 | 79.9 | 81.0 | 0 | 0 |
| Long. | 231 | 254 | 8.0 | 165 | 27.8 | 80.1 | 82.0 | 0 | 0 |
| Long. | 230 | 251 | 10.0 | 132 | 26.3 | 80.1 | 81.4 | 0 | 0 |
| Long. | 227 | 252 | 8.0 | 110 | 26.2 | 80.0 | 81.0 | 0 | 0 |
| AVG | 228 | 253 | 8.7 | 137 | 26.4 | 80.0 | 81.5 | 0 | 0 |
| -320 Trans. | 219 | 270 | 9.5 | 133 | 27.2 | 79.8 | 81.5 | 0 | 0 |
| Trans. | 225 | 274 | 9.5 | 122 | 27.3 | 79.8 | 81.0 | 0 | 0 |
| Trans. | 223 | 274 | 7.5 | 124 | 28.5 | 80.0 | 82.0 | 0 | 0 |
| Trans. | 219 | 272 | 8.5 | 142 | 28.3 | 80.0 | 80.0 | 0 | 0 |
| Trans. | 214 | 271 | 9.5 | 138 | 29.8 | 80.7 | 81.7 | 0 | 0 |
| AVG | 220 | 272 | 8.9 | 132 | 28.2 | 80.1 | 81.2 | 0 | 0 |
| -423 Long. | 261 | 291 | 8.5 | 164 | 27.1 | 79.0 | 81.1 | 0 | 0 |
| Long. | 257 | 290 | 7.5 | 164 | 28.9 | 79.4 | 80.0 | 0 | 0 |
| Long. | 264 | 289 | 8.0 | 176 | 28.3 | 81.0 | 81.0 | 0 | 0 |
| Long. | 262 | 293 | 9.0 | 199 | 28.4 | 80.5 | 82.0 | 0 | 0 |
| Long. | 259 | 294 | 9.0 | 188 | 28.6 | 80.0 | 80.2 | 0 | 0 |
| AVG | 261 | 291 | 8.4 | 178 | 28.3 | 80.0 | 80.9 | 0 | 0 |
| -423 Trans. | 261 | 314 | 9.5 | 164 | 30.8 | 79.8 | 81.0 | 0 | 0 |
| Trans. | 261 | 322 | 8.0 | 161 | 30.0 | 79.9 | 80.8 | 0 | 0 |
| Trans. | 266 | 301 | 8.5 | 183 | 28.8 | 79.5 | 79.7 | 0 | 0 |
| Trans. | 262 | 318 | 9.0 | 183 | 27.1 | 79.2 | 79.6 | 0 | 0 |
| Trans. | 280 | 315 | 11.0 | 164 | 28.9 | 79.4 | 81.1 | 0 | 0 |
| AVG | 266 | 314 | 9.2 | 171 | 29.1 | 79.6 | 80.4 | 0 | 0 |

Table 7. (Cont)

| TEST TEMP (°F) | DIR | NOTCH T.S. (K _t = 3.2) (KSI) | FRACTURE TOUGHNESS, K (PSI √IN.) | NOTCH/UNNOTCH TENSILE RATIO | NOTCH T.S. (K _t = 6.3) (KSI) | FRACTURE TOUGHNESS, K (PSI √IN.) | NOTCH/UNNOTCH TENSILE RATIO |
|----------------------|---------------|---|-------------------------------------|-----------------------------------|---|--|-----------------------------------|
| 78 | Long. | 196 (3.2) | 54.8 | | 198 (6.3) | 55.6 | |
| | Long. | 198 (3.2) | 55.5 | | 199 (6.3) | 55.6 | |
| | Long. | 198 (3.2) | 55.4 | | 198 (6.3) | 55.4 | |
| | Long. | 198 (3.2) | 55.4 | | 197 (6.3) | 55.3 | |
| | Long. AVG | 198 198 | 55.4 55.3 | 1.10 | 199 198 | 55.8 55.5 | 1.10 |
| 78 | Trans. | 217 (3.2) | 60.7 | | 206 (6.3) | 57.7 | |
| | Trans. | 219 (3.2) | 61.4 | | 196 (6.3) | 54.9 | |
| | Trans. | 222 (3.2) | 62.2 | | 210 (6.3) | 58.8 | |
| | Trans. | 221 (3.2) | 61.8 | | 196 (6.3) | 52.8 | |
| | Trans. AVG | 196 215 | 54.8 60.2 | 1.08 | 189 199 | 50.2 54.9 | 1.00 |
| -100 | Long. | 223 (3.2) | 62.4 | | 224 (6.3) | 62.7 | |
| | Long. | 221 (3.2) | 61.9 | | 226 (6.3) | 63.3 | |
| | Long. | 221 (3.2) | 61.9 | | 223 (6.3) | 62.5 | |
| | Long. | 224 (3.2) | 62.6 | | 223 (6.3) | 62.4 | |
| | Long. AVG | 222 222 | 62.0 62.2 | 1.09 | 222 224 | 62.0 62.6 | 1.10 |
| -100 | Trans. | 261 (3.2) | 73.2 | | 244 (6.3) | 68.4 | |
| | Trans. | 260 (3.2) | 72.8 | | 239 (6.3) | 66.8 | |
| | Trans. | 260 (3.2) | 72.9 | | 226 (6.3) | 63.2 | |
| | Trans. | 260 (3.2) | 72.8 | | 244 (6.3) | 68.5 | |
| | Trans. AVG | 263 261 | 73.5 73.0 | 1.18 | 240 239 | 67.2 66.8 | 1.08 |

| | | | | | |
|-------------|------------|-------------|------------|-------------|-------------|
| -320 Long. | 280 (3.2) | 78.4 | 279 (6.3) | 78.1 | |
| Long. | 279 (3.2) | 78.0 | 279 (6.3) | 78.1 | |
| Long. | 278 (3.2) | 77.8 | 278 (6.3) | 77.7 | |
| Long. | 278 (3.2) | 77.9 | 279 (6.3) | 78.1 | |
| Long. | 277 (3.2) | 77.5 | 279 (6.3) | 78.1 | 1.10 |
| AVG | <u>278</u> | <u>77.9</u> | <u>279</u> | <u>78.0</u> | <u>1.10</u> |
| -320 Trans. | 321 (3.2) | 90.0 | 296 (6.3) | 83.0 | |
| Trans. | 321 (3.2) | 90.0 | 305 (6.3) | 85.4 | |
| Trans. | 332 (3.2) | 93.0 | 298 (6.3) | 83.5 | |
| Trans. | 336 (3.2) | 94.2 | 304 (6.3) | 85.0 | |
| Trans. | 335 (3.2) | 93.8 | 289 (6.3) | 80.9 | 1.10 |
| AVG | <u>329</u> | <u>92.2</u> | <u>298</u> | <u>83.6</u> | <u>1.10</u> |
| -423 Long. | 329 (3.2) | 92.2 | 330 (6.3) | 92.3 | |
| Long. | 334 (3.2) | 93.5 | 323 (6.3) | 90.6 | |
| Long. | 331 (3.2) | 92.8 | 335 (6.3) | 93.7 | |
| Long. | 335 (3.2) | 93.8 | 327 (6.3) | 91.6 | |
| Long. | 339 (3.2) | 94.9 | 327 (6.3) | 91.6 | 1.13 |
| AVG | <u>334</u> | <u>93.4</u> | <u>328</u> | <u>92.0</u> | <u>1.13</u> |
| -423 Trans. | 393 (3.2) | 110 | 340 (6.3) | 95.1 | |
| Trans. | 384 (3.2) | 108 | 324 (6.3) | 90.7 | |
| Trans. | 381 (3.2) | 107 | 327 (6.3) | 91.6 | |
| Trans. | 388 (3.2) | 109 | 323 (6.3) | 90.4 | |
| Trans. | 386 (3.2) | 108 | 330 (6.3) | 92.3 | 1.05 |
| AVG | <u>386</u> | <u>108</u> | <u>329</u> | <u>92.0</u> | <u>1.05</u> |

Table 7. (Cont)

| TEST TEMP (°F) | DIR | NOTCH T.S. FRACTURE TOUGHNESS K (PSI √IN.) | NOTCH/UNNOTCH TENSILE RATIO | WELD T.S. (KSI) | WELD ELONG (%) | JOINT EFF (%) | HARDNESS(15-N)% MARTENSITE | | | |
|----------------|--------|--|-----------------------------|-----------------|----------------|---------------|----------------------------|--------------------|--------------------|--------------------|
| | | | | | | | HEAT AFFECTED ZONE | WELD AFFECTED ZONE | HEAT AFFECTED ZONE | WELD AFFECTED ZONE |
| 78 | Long. | 167(20.8) | 80.6 | 86.6 | 2.5 | | 79.5 | 67.1 | 0 | 0 |
| | Long. | 152(20.8) | 73.3 | 85.8 | 1.5 | | 79.9 | 63.0 | 0 | 0 |
| | Long. | 157(20.8) | 75.7 | 88.3 | 1.5 | | 79.0 | 66.8 | 0 | 0 |
| | Long. | 167(20.8) | 80.7 | 85.8 | 2.5 | | 80.5 | 63.4 | 0 | 0 |
| | Long. | 160(20.8) | 77.3 | 87.1 | 2.0 | | 79.0 | 64.0 | 0 | 0 |
| | AVG | 161 | 77.5 | 86.7 | 2.0 | 48 | 79.6 | 64.9 | 0 | 0 |
| 78 | Trans. | 118(19.8) | 56.8 | 86.9 | 2.5 | | 79.9 | 64.2 | 0 | 0 |
| | Trans. | 116(19.8) | 56.2 | 82.8 | 2.0 | | 80.0 | 69.1 | 0 | 0 |
| | Trans. | 121(19.8) | 58.3 | 84.0 | 2.0 | | 79.5 | 65.0 | 0 | 0 |
| | Trans. | 127(19.8) | 61.4 | 86.3 | 2.0 | | 79.5 | 65.8 | 0 | 0 |
| | Trans. | 123(19.8) | 59.3 | 87.3 | 2.0 | | 79.2 | 65.6 | 0 | 0 |
| | AVG | 121 | 58.4 | 85.5 | 2.1 | 43 | 79.6 | 65.9 | 0 | 0 |
| -100 | Long. | 185(20.8) | 89.2 | 111 | 2.5 | | 80.7 | 66.2 | 0 | 0 |
| | Long. | 167(20.8) | 80.9 | 108 | 2.0 | | 79.7 | 65.6 | 0 | 0 |
| | Long. | 197(20.8) | 95.2 | 109 | 2.5 | | 79.7 | 67.8 | 0 | 0 |
| | Long. | 185(20.8) | 89.3 | 106 | 2.5 | | 79.8 | 65.2 | 0 | 0 |
| | Long. | 187(20.8) | 90.5 | 112 | 2.0 | | 79.8 | 65.0 | 0 | 0 |
| | AVG | 184 | 89.0 | 109 | 2.3 | 54 | 79.9 | 66.0 | 0 | 0 |
| -100 | Trans. | 158(19.8) | 76.3 | 110 | 2.0 | | 79.8 | 65.2 | 0 | 0 |
| | Trans. | 170(19.8) | 82.2 | 112 | 2.0 | | 79.9 | 66.5 | 0 | 0 |
| | Trans. | 147(19.8) | 71.1 | 109 | 2.5 | | 79.9 | 66.5 | 0 | 0 |
| | Trans. | 160(19.8) | 77.1 | 109 | 2.0 | | 79.7 | 68.0 | 0 | 0 |
| | Trans. | 161(19.8) | 78.0 | 110 | 2.5 | | 80.5 | 65.2 | 0 | 0 |
| | AVG | 159 | 76.9 | 110 | 2.2 | 50 | 80.0 | 66.3 | 0 | 0 |

| | | | | | | | | | |
|------|--------|-----------|------|-----|-----|------|------|------|----|
| -320 | Long. | 208(20.8) | 100 | 158 | 2.5 | 79.4 | 71.3 | 0 | 0 |
| | Long. | 191(20.8) | 92.1 | 160 | 2.5 | 79.8 | 68.8 | 0 | 0 |
| | Long. | 230(20.8) | 111 | 162 | 2.5 | 80.4 | 66.3 | 0 | 0 |
| | Long. | 221(20.8) | 107 | 162 | 2.5 | 79.2 | 64.4 | 0 | 0 |
| | Long. | 218(20.8) | 105 | 170 | 2.0 | 80.0 | 66.6 | 0 | 0 |
| | Avg | 214 | 103 | 162 | 2.4 | 79.8 | 67.5 | 0 | 0 |
| | | | | | | | | 0.85 | 64 |
| -320 | Trans. | 163(19.8) | 78.6 | 168 | 2.5 | 79.0 | 67.5 | 0 | 0 |
| | Trans. | 177(19.8) | 85.5 | 169 | 2.0 | 80.7 | 68.3 | 0 | 0 |
| | Trans. | 181(19.8) | 87.5 | 168 | 2.0 | 79.7 | 69.2 | 0 | 0 |
| | Trans. | 195(19.8) | 94.0 | 166 | 2.5 | 79.5 | 67.0 | 0 | 0 |
| | Trans. | 161(19.8) | 77.8 | 166 | 2.5 | 80.0 | 68.2 | 0 | 0 |
| | Avg | 175 | 84.7 | 167 | 2.3 | 79.8 | 68.0 | 0 | 0 |
| | | | | | | | | 0.64 | 61 |
| -423 | Long. | 215(20.8) | 104 | 203 | 1.5 | 79.8 | 69.1 | 0 | 0 |
| | Long. | 224(20.8) | 108 | 209 | 2.0 | 79.4 | 68.9 | 0 | 0 |
| | Long. | 189(20.8) | 91.5 | 209 | 2.0 | 79.4 | 71.1 | 0 | 0 |
| | Long. | 209(20.8) | 101 | 213 | 2.0 | 79.9 | 70.6 | 0 | 0 |
| | Long. | 212(20.8) | 103 | 206 | 2.0 | 79.9 | 69.3 | 0 | 0 |
| | Avg | 210 | 102 | 208 | 1.9 | 79.7 | 69.8 | 0 | 0 |
| | | | | | | | | 0.72 | 71 |
| -423 | Trans. | 189(19.8) | 91.1 | 192 | 2.5 | 79.0 | 69.0 | 0 | 0 |
| | Trans. | 206(19.8) | 99.5 | 196 | 2.0 | 79.2 | 67.5 | 0 | 0 |
| | Trans. | 172(19.8) | 82.9 | 187 | 2.0 | 79.4 | 67.7 | 0 | 0 |
| | Trans. | 183(19.8) | 88.4 | 191 | 1.5 | 79.0 | 69.8 | 0 | 0 |
| | Trans. | 209(19.8) | 101 | 199 | 2.0 | 79.0 | 69.9 | 0 | 0 |
| | Avg | 192 | 92.6 | 193 | 2.0 | 79.1 | 68.8 | 0 | 0 |
| | | | | | | | | 0.61 | 61 |



Table 8. Properties of AM-355 Stainless Steel (0.032 In. Sheet, Wallingford Steel, Heat No. 38174)

| TEST TEMP (°F) | DIR | F _{ty} (KSI) | F _{tu} KSI | ELONG (%) | PROPORTIONAL LIMIT (KSI) | ELASTIC MODULUS (PSI x 10 ⁶) | HARDNESS (15-N) | | % MARTENSITE | |
|----------------|--------|-----------------------|---------------------|-----------|--------------------------|--|-------------------|----------------|-----------------|----------------|
| | | | | | | | REDUCTION SECTION | FRACTURED EDGE | REDUCED SECTION | FRACTURED EDGE |
| 78 | Long. | 281 | 294 | 5.0 | 148 | 28.0 | 87.5 | 88.3 | 97 | 98 |
| | Long. | 272 | 298 | 5.5 | 138 | 28.9 | 86.5 | 87.7 | 96 | 99 |
| | Long. | 278 | 299 | 6.0 | 134 | 28.4 | 87.5 | 89.5 | 97 | 98 |
| | Long. | 278 | 294 | 5.0 | 142 | 27.2 | 86.0 | 88.9 | 97 | 97 |
| | Long. | 283 | 298 | 5.5 | 152 | 26.1 | 86.3 | 88.1 | 97 | 98 |
| | AVG | 278 | 297 | 5.4 | 143 | 27.7 | 86.8 | 88.5 | 97 | 98 |
| 78 | Trans. | 251 | 288 | 7.0 | 120 | 29.9 | 87.6 | 89.3 | 96 | 97 |
| | Trans. | 254 | 286 | 7.0 | 142 | 28.2 | 86.2 | 89.2 | 96 | 98 |
| | Trans. | 250 | 283 | 7.0 | 131 | 28.7 | 88.0 | 89.6 | 97 | 98 |
| | Trans. | 250 | 286 | 7.5 | 127 | 28.4 | 86.7 | 87.5 | 96 | 98 |
| | Trans. | 248 | 286 | 6.5 | 141 | 29.4 | 86.2 | 86.6 | 97 | 98 |
| | AVG | 251 | 286 | 7.0 | 132 | 28.9 | 86.9 | 88.4 | 96 | 98 |
| -100 | Long. | 285 | 311 | 17.5 | 165 | 27.9 | 89.4 | 88.0 | 99 | 99 |
| | Long. | 294 | 311 | 16.5 | 163 | 28.5 | 87.1 | 88.7 | 98 | 98 |
| | Long. | 290 | 309 | 17.0 | 188 | 26.4 | 88.7 | 89.0 | 98 | 100 |
| | Long. | 286 | 306 | 17.0 | 162 | 26.6 | 88.4 | 88.6 | 100 | 100 |
| | Long. | 281 | 305 | 17.0 | 163 | 26.6 | 89.3 | 89.1 | 99 | 100 |
| | AVG | 287 | 308 | 17.0 | 168 | 27.2 | 88.6 | 88.7 | 99 | 99 |
| -100 | Trans. | 253 | 310 | 12.0 | 153 | 30.8 | 89.0 | 89.2 | 98 | 99 |
| | Trans. | 249 | 314 | 12.0 | 175 | 27.3 | 87.2 | 87.9 | 98 | 98 |
| | Trans. | 249 | 316 | 10.5 | 154 | 27.7 | 88.2 | 87.5 | 99 | 100 |
| | Trans. | 254 | 313 | 12.5 | 141 | 28.9 | 88.4 | 89.9 | 98 | 99 |
| | Trans. | 253 | 315 | 10.5 | 156 | 30.1 | 89.5 | 89.8 | 100 | 99 |
| | AVG | 252 | 314 | 11.5 | 156 | 29.0 | 88.5 | 88.9 | 99 | 99 |

| | | | | | | | | | | |
|------|--------|-----|-----|------|-----|------|------|------|----|----|
| -320 | Long. | 329 | 349 | 9.0 | 171 | 28.4 | 85.9 | 87.4 | 96 | 97 |
| | Long. | 358 | 356 | 10.0 | 204 | 27.2 | 86.2 | 87.6 | 96 | 98 |
| | Long. | 324 | 353 | 10.0 | 183 | 27.8 | 86.0 | 87.2 | 97 | 99 |
| | Long. | - | 354 | 9.5 | - | - | 86.8 | 87.5 | 98 | 99 |
| | Long. | - | 350 | 9.5 | - | - | 88.8 | 88.5 | 96 | 97 |
| | Long. | 316 | 354 | 9.5 | 191 | 28.0 | 86.0 | 87.2 | 97 | 98 |
| | Long. | 333 | 352 | 9.0 | 208 | 28.3 | 88.5 | 86.7 | 96 | 97 |
| | AVG | 328 | 353 | 9.5 | 191 | 27.9 | 86.9 | 87.4 | 97 | 98 |
| -320 | Trans. | 294 | 348 | 2.0 | 184 | 27.6 | 87.0 | 87.2 | 97 | 98 |
| | Trans. | 278 | 335 | 2.0 | 173 | 27.3 | 87.1 | 87.4 | 98 | 97 |
| | Trans. | 277 | 345 | 2.0 | 176 | 30.1 | 86.6 | 87.8 | 99 | 99 |
| | Trans. | 294 | 348 | 2.0 | 176 | 29.4 | 87.8 | 88.6 | 99 | 98 |
| | Trans. | 289 | 336 | 1.5 | 192 | 28.9 | 86.6 | 87.2 | 98 | 98 |
| | AVG | 286 | 342 | 1.9 | 180 | 28.7 | 87.0 | 87.6 | 98 | 98 |
| -423 | Long. | 311 | 311 | 0 | 201 | 28.1 | 86.2 | 87.0 | 97 | 98 |
| | Long. | 346 | 346 | 0 | 228 | 28.7 | 87.0 | 87.3 | 99 | 99 |
| | Long. | - | 364 | 0 | - | - | 86.8 | 87.4 | 98 | 99 |
| | Long. | - | 355 | 0 | - | - | 87.8 | 87.8 | 99 | 99 |
| | Long. | - | 358 | 0 | - | - | 88.4 | 88.6 | 98 | 99 |
| | AVG | 329 | 347 | 0 | 215 | 28.4 | 87.2 | 87.6 | 98 | 99 |
| -423 | Trans. | 319 | 319 | 0 | 198 | 29.0 | 86.8 | 87.1 | 97 | 98 |
| | Trans. | - | 344 | 0 | - | - | 86.8 | 87.6 | 97 | 97 |
| | Trans. | - | 349 | 0 | - | - | 87.0 | 87.2 | 98 | 99 |
| | Trans. | - | 353 | 0 | - | - | 88.2 | 88.2 | 99 | 99 |
| | Trans. | - | 331 | 0 | - | - | 87.7 | 88.4 | 98 | 99 |
| | AVG | 319 | 339 | 0 | 198 | 29.0 | 87.3 | 87.7 | 98 | 98 |



Table 8. (Cont)

| TEST TEMP (°F) | DIR | NOTCH T.S. FRACTURE (KSI) | TOUGHNESS, K (PSI $\sqrt{\text{IN.}}$) | NOTCH/ UNNOTCH TENSILE RATIO | WELD T.S. (KSI) | WELD ELONG (%) | JOINT EFF (%) | HARDNESS (15-N) | | % MARTENSITE | |
|----------------------|--------|------------------------------|--|---------------------------------------|-----------------|----------------------|---------------------|--------------------------|--------------------------|--------------------------|--------------------------|
| | | | | | | | | HEAT AFFECTED ZONE | WELD AFFECTED ZONE | HEAT AFFECTED ZONE | WELD AFFECTED ZONE |
| 78 | Long. | 257 (6.2) | 71.9 | | 226 | 2.0 | | 85.8 | 84.5 | 95 | 98 |
| | Long. | 248 (6.2) | 69.3 | | 216 | 2.5 | | 86.4 | 82.6 | 96 | 98 |
| | Long. | 239 (6.1) | 66.9 | | 226 | 2.0 | | 86.4 | 85.2 | 96 | 98 |
| | Long. | 270 (6.2) | 75.5 | | 222 | 2.0 | | 86.0 | 85.0 | 95 | 98 |
| | Long. | 252 (6.2) | 70.7 | | 218 | 2.0 | | 85.7 | 80.0 | 95 | 98 |
| | AVG | 253 | 70.9 | 0.85 | 222 | 2.1 | 75 | 86.1 | 83.5 | 95 | 98 |
| 78 | Trans. | 228 (6.5) | 63.9 | | 223 | 2.0 | | 87.2 | 84.5 | 96 | 98 |
| | Trans. | 227 (6.5) | 63.5 | | 223 | 2.5 | | 85.9 | 85.2 | 95 | 98 |
| | Trans. | 228 (6.6) | 63.8 | | 218 | 2.5 | | 87.0 | 85.4 | 96 | 97 |
| | Trans. | 240 (6.6) | 67.2 | | 217 | 2.5 | | 90.0 | 85.4 | 96 | 98 |
| | Trans. | 233 (6.6) | 65.3 | | 215 | 2.0 | | 86.3 | 84.7 | 96 | 98 |
| | AVG | 231 | 64.7 | 0.81 | 219 | 2.3 | 73 | 87.3 | 85.0 | 96 | 98 |
| -100 | Long. | 287 (6.2) | 80.3 | | 288 | 2.5 | | 87.8 | 86.0 | 96 | 100 |
| | Long. | 278 (6.2) | 77.4 | | 290 | 2.0 | | 87.5 | 86.5 | 96 | 99 |
| | Long. | 288 (6.2) | 80.6 | | 291 | 2.5 | | 87.6 | 83.7 | 97 | 98 |
| | Long. | 263 (6.2) | 73.7 | | 287 | 2.5 | | 87.2 | 85.2 | 97 | 99 |
| | Long. | 260 (6.2) | 72.9 | | 290 | 2.5 | | 86.5 | 88.4 | 96 | 99 |
| | AVG | 275 | 77.0 | 0.89 | 289 | 2.4 | 94 | 87.3 | 86.0 | 96 | 99 |
| -100 | Trans. | 251 (6.6) | 70.3 | | 283 | 2.5 | | 88.2 | 88.7 | 97 | 98 |
| | Trans. | 237 (6.6) | 66.4 | | 284 | 2.0 | | 88.5 | 86.6 | 97 | 98 |
| | Trans. | 243 (6.6) | 68.0 | | 279 | 1.5 | | 87.5 | 87.2 | 96 | 98 |
| | Trans. | 246 (6.6) | 68.9 | | 283 | 1.5 | | 86.2 | 84.3 | 96 | 99 |
| | Trans. | 237 (6.6) | 66.3 | | 282 | 1.5 | | 86.6 | 88.9 | 95 | 100 |
| | AVG | 243 | 68.0 | 0.77 | 282 | 1.8 | 90 | 87.4 | 87.2 | 96 | 99 |



| | | | | | | | | |
|-------------|-----------|------|-----|-----|------|------|----|-----|
| -320 Long. | 168 (6.2) | 47.0 | 264 | 1.0 | 85.8 | 85.8 | 96 | 97 |
| Long. | 164 (6.2) | 45.9 | 265 | 1.0 | 86.1 | 85.1 | 96 | 98 |
| Long. | 163 (6.2) | 45.7 | 235 | 0.0 | 86.1 | 84.7 | 96 | 98 |
| Long. | 147 (6.2) | 41.1 | 294 | 1.0 | 87.1 | 85.9 | 96 | 99 |
| Long. | 176 (6.2) | 49.3 | 298 | 1.0 | 86.5 | 87.3 | 97 | 98 |
| Avg | 164 | 45.8 | 271 | 0.8 | 86.3 | 84.8 | 96 | 98 |
| | | 0.46 | | | | | | 77 |
| -320 Trans. | 169 (6.6) | 47.2 | 283 | 1.0 | 87.9 | 87.0 | 97 | 98 |
| Trans. | 166 (6.6) | 46.5 | 326 | 1.0 | 88.6 | 85.8 | 97 | 98 |
| Trans. | 192 (6.6) | 53.8 | 291 | 1.0 | 86.8 | 86.1 | 97 | 100 |
| Trans. | 170 (6.6) | 47.6 | 283 | 1.0 | 86.5 | 88.2 | 96 | 99 |
| Trans. | 164 (6.6) | 45.9 | 312 | 1.0 | 87.1 | 88.1 | 96 | 99 |
| Avg | 172 | 48.2 | 299 | 1.0 | 87.4 | 87.0 | 97 | 99 |
| | | 0.50 | | | | | | 87 |
| -423 Long. | 113 (6.2) | 31.7 | 140 | 0.5 | 86.3 | 82.7 | 95 | 92 |
| Long. | 102 (6.2) | 28.6 | 138 | 0.5 | 89.3 | 83.1 | 95 | 93 |
| Long. | 117 (6.2) | 32.8 | 142 | 0.5 | 86.8 | 85.2 | 95 | 91 |
| Long. | 119 (6.2) | 33.3 | 139 | 0.5 | 88.0 | 84.5 | 96 | 90 |
| Long. | 144 (6.2) | 40.3 | 151 | 0.5 | 87.6 | 85.0 | 95 | 95 |
| Avg | 119 | 33.3 | 142 | 0.5 | 87.6 | 84.1 | 96 | 92 |
| | | 0.34 | | | | | | 41 |
| -423 Trans. | 133 (6.6) | 37.2 | 133 | 0.5 | 88.8 | 86.4 | 96 | 91 |
| Trans. | 147 (6.6) | 41.2 | 139 | 0.5 | 87.9 | 84.5 | 96 | 92 |
| Trans. | 135 (6.6) | 37.9 | 136 | 0.5 | 88.2 | 85.6 | 95 | 91 |
| Trans. | 83 (6.6) | 23.3 | 155 | 0.5 | 86.8 | 87.8 | 95 | 95 |
| Trans. | 130 (6.6) | 36.3 | 139 | 0.5 | 87.0 | 83.1 | 96 | 92 |
| Avg | 126 | 35.2 | 140 | 0.5 | 87.7 | 85.5 | 96 | 92 |
| | | 0.37 | | | | | | 41 |



Table 9. Properties of 2014-T6 Aluminum Alloy (0.063 In. Sheet, Aluminum Company of America, AMS-4029)

| TEST TEMP (°F) | DIR | F _{ty} (KSI) | F _{tu} (KSI) | ELONG (%) | PROPORTIONAL LIMIT (KSI) | ELASTIC MODULUS (PSI X 10 ⁶) | HARDNESS (15-N) | |
|----------------|--------|-----------------------|-----------------------|-----------|--------------------------|--|-----------------|----------------|
| | | | | | | | REDUCED SECTION | FRACTURED EDGE |
| 78 | Long. | 66.3 | 72.0 | 10.0 | 54.8 | 10.0 | 60.0 | 60.5 |
| | Long. | 65.2 | 71.5 | 10.0 | 48.3 | 10.2 | 60.0 | 60.1 |
| | Long. | 65.3 | 71.7 | 10.0 | 53.0 | 9.6 | 60.0 | 59.7 |
| | Long. | 64.6 | 71.4 | 10.0 | 51.6 | 10.1 | 60.0 | 60.2 |
| | Long. | 64.7 | 71.6 | 10.0 | 52.2 | 10.3 | 60.8 | 61.0 |
| | AVG | 65.2 | 71.6 | 10.0 | 52.0 | 10.0 | 60.2 | 60.3 |
| 78 | Trans. | 63.4 | 70.7 | 11.0 | 43.3 | 9.7 | 59.0 | 59.2 |
| | Trans. | 62.7 | 70.8 | 10.5 | 43.6 | 9.9 | 58.8 | 59.0 |
| | Trans. | 63.3 | 70.9 | 10.0 | 43.6 | 10.1 | 60.0 | 62.0 |
| | Trans. | 63.1 | 71.0 | 10.0 | 45.7 | 10.3 | 59.0 | 61.0 |
| | Trans. | 63.3 | 71.1 | 10.0 | 45.7 | 10.1 | 60.0 | 61.7 |
| | AVG | 63.2 | 70.9 | 10.3 | 44.4 | 10.0 | 59.4 | 60.6 |
| -100 | Long. | 67.7 | 74.0 | 10.0 | 60.3 | 10.1 | 62.1 | 61.1 |
| | Long. | 68.2 | 75.0 | 10.5 | 63.2 | 11.1 | 61.8 | 60.9 |
| | Long. | 68.6 | 74.9 | 10.0 | 51.1 | 11.0 | 60.5 | 60.3 |
| | Long. | 68.2 | 74.5 | 10.5 | 52.6 | 9.7 | 59.8 | 59.8 |
| | Long. | 68.1 | 74.5 | 11.5 | 51.0 | 11.0 | 60.3 | 60.0 |
| | AVG | 68.2 | 74.6 | 10.5 | 55.6 | 10.6 | 60.9 | 60.4 |
| -100 | Trans. | 66.1 | 73.9 | 10.0 | 50.3 | 11.3 | 59.9 | 58.8 |
| | Trans. | 66.1 | 73.9 | 11.0 | 50.1 | 9.7 | 60.0 | 60.0 |
| | Trans. | 66.0 | 73.9 | 10.5 | 52.4 | 11.0 | 60.1 | 60.2 |
| | Trans. | 65.5 | 74.2 | 10.0 | 42.9 | 9.6 | 60.2 | 60.2 |
| | Trans. | 66.0 | 73.9 | 9.5 | 43.9 | 10.1 | 59.5 | 60.1 |
| | AVG | 65.9 | 74.0 | 10.2 | 47.9 | 10.4 | 59.9 | 59.9 |

| | | | | | | | | |
|------|--------|------|------|------|------|------|------|------|
| -320 | Long. | 74.8 | 85.5 | 13.0 | 61.4 | 11.4 | 59.0 | 60.6 |
| | Long. | 72.8 | 85.5 | 11.0 | 61.7 | 10.8 | 59.6 | 60.6 |
| | Long. | 74.4 | 85.5 | 12.5 | 54.6 | 11.4 | 61.9 | 59.1 |
| | Long. | 74.2 | 85.2 | 13.0 | 54.4 | 11.2 | 59.1 | 59.7 |
| | Long. | 74.3 | 86.0 | 12.5 | 54.1 | 11.8 | 60.0 | 59.2 |
| | AVG | 74.1 | 85.5 | 12.4 | 57.2 | 11.3 | 59.9 | 59.8 |
| -320 | Trans. | 70.7 | 84.5 | 12.5 | 54.7 | 10.7 | 59.5 | 60.2 |
| | Trans. | 66.7 | 84.5 | 12.5 | 47.7 | 10.3 | 59.6 | 60.1 |
| | Trans. | 70.0 | 84.5 | 12.0 | 54.0 | 11.6 | 60.1 | 60.7 |
| | Trans. | 70.1 | 84.4 | 12.5 | 47.9 | 11.8 | 59.7 | 60.6 |
| | Trans. | 69.0 | 84.4 | 12.5 | 51.7 | 11.4 | 59.4 | 59.9 |
| | AVG | 69.3 | 84.5 | 12.4 | 51.2 | 11.2 | 59.7 | 60.3 |
| -423 | Long. | 84.6 | 102 | 11.0 | 74.3 | 11.4 | 61.3 | 61.2 |
| | Long. | 83.0 | 99.2 | 14.5 | 76.0 | 11.0 | 60.5 | 60.9 |
| | Long. | 83.5 | 103 | 15.5 | 62.3 | 11.9 | 61.9 | 61.1 |
| | Long. | 83.1 | 101 | 16.0 | 65.9 | 12.2 | 60.2 | 61.0 |
| | Long. | 83.0 | 100 | 16.5 | 72.7 | 12.3 | 60.7 | 61.3 |
| | AVG | 83.4 | 101 | 14.7 | 70.2 | 11.8 | 60.9 | 61.1 |
| -423 | Trans. | 81.2 | 101 | 14.0 | 60.9 | 11.9 | 59.5 | 60.5 |
| | Trans. | 80.0 | 99.8 | 14.5 | 65.3 | 11.7 | 61.2 | 60.8 |
| | Trans. | 83.1 | 103 | 15.5 | 55.1 | 12.3 | 59.8 | 61.8 |
| | Trans. | 82.6 | 102 | 15.5 | 66.9 | 12.1 | 60.8 | 61.7 |
| | Trans. | 82.0 | 102 | 15.5 | 67.0 | 10.4 | 61.5 | 60.5 |
| | AVG | 81.8 | 102 | 15.0 | 63.0 | 11.7 | 60.6 | 61.3 |

Table 9 (Cont)

| TEST TEMP (°F) | DIR | NOTCH T.S. (K _t =3.2) (KSI) | FRACTURE TOUGHNESS, K (PSI √IN.) | NOTCH/ UNNOTCH TENSILE RATIO | NOTCH T.S. (K _t =6.3) (KSI) | FRACTURE TOUGHNESS, K (PSI √IN) | NOTCH/ UNNOTCH TENSILE RATIO |
|----------------------|---------------|--|-------------------------------------|---------------------------------------|--|------------------------------------|---------------------------------------|
| 78 | Long. | 76.6 (3.1) | 21.4 | | 75.6 (6.3) | 21.2 | |
| | Long. | 77.6 (3.1) | 21.7 | | 75.2 (6.4) | 21.1 | |
| | Long. | 78.4 (3.1) | 22.0 | | 75.7 (6.4) | 21.2 | |
| | Long. | 78.0 (3.1) | 21.8 | | 74.9 (6.3) | 21.0 | |
| | Long. AVG | 77.6 77.6 | 21.7 21.7 | 1.08 | 75.4 75.4 | 21.1 21.1 | 1.05 |
| 78 | Trans. | 77.0 (3.2) | 21.6 | | 72.5 (6.3) | 20.3 | |
| | Trans. | 77.2 (3.2) | 21.6 | | 70.7 (6.3) | 19.8 | |
| | Trans. | 77.3 (3.2) | 21.6 | | 73.5 (6.3) | 20.6 | |
| | Trans. | 78.6 (3.2) | 22.0 | | 72.6 (6.3) | 20.3 | |
| | Trans. AVG | 82.1 78.4 | 23.0 22.0 | 1.11 | 70.6 72.0 | 19.8 20.2 | 1.02 |
| -100 | Long. | 80.1 (3.1) | 22.4 | | 77.4 (6.4) | 21.7 | |
| | Long. | 80.6 (3.1) | 22.6 | | 77.4 (6.4) | 21.7 | |
| | Long. | 80.6 (3.2) | 22.6 | | 77.6 (6.4) | 21.7 | |
| | Long. | 79.8 (3.2) | 22.3 | | 76.6 (6.4) | 21.7 | |
| | Long. AVG | 79.5 80.1 | 22.3 22.4 | 1.07 | 77.9 77.4 | 21.8 21.7 | 1.04 |
| -100 | Trans. | 79.1 (3.2) | 22.1 | | 74.6 (6.3) | 21.2 | |
| | Trans. | 79.1 (3.2) | 22.1 | | 74.8 (6.3) | 20.2 | |
| | Trans. | 79.4 (3.2) | 22.2 | | 71.4 (6.3) | 20.0 | |
| | Trans. | 78.5 (3.2) | 22.0 | | 74.4 (6.3) | 20.8 | |
| | Trans. AVG | 78.3 78.9 | 22.0 22.1 | 1.07 | 74.4 73.9 | 20.8 20.7 | 1.00 |

| | | | | | | |
|------|--------|------------|------|------------|------|------|
| -320 | Long. | 90.2 (3.2) | 25.3 | 84.0 (6.4) | 23.5 | 0.98 |
| | Long. | 90.4 (3.2) | 25.3 | 86.2 (6.4) | 24.1 | |
| | Long. | 90.0 (3.2) | 25.2 | 85.4 (6.4) | 23.9 | |
| | Long. | 90.4 (3.2) | 25.3 | 83.6 (6.5) | 23.4 | |
| | Long. | 91.1 (3.2) | 25.5 | 79.6 (6.4) | 22.3 | |
| | AVG | 90.4 | 25.3 | 83.8 | 23.5 | |
| -320 | Trans. | 89.1 (3.2) | 25.0 | 75.7 (6.3) | 21.2 | 0.93 |
| | Trans. | 89.3 (3.2) | 25.0 | 82.1 (6.3) | 23.0 | |
| | Trans. | 89.0 (3.2) | 25.0 | 76.6 (6.4) | 21.4 | |
| | Trans. | 88.2 (3.2) | 24.7 | 80.4 (6.3) | 22.5 | |
| | Trans. | 88.0 (3.2) | 24.6 | 78.8 (6.3) | 22.1 | |
| | AVG | 88.7 | 24.8 | 78.7 | 22.0 | |
| -423 | Long. | 101 (3.2) | 28.3 | 101 (6.4) | 28.3 | 0.92 |
| | Long. | 104 (3.1) | 29.1 | 84.2 (6.5) | 23.6 | |
| | Long. | 105 (3.1) | 29.4 | 94.1 (6.4) | 26.3 | |
| | Long. | 102 (3.1) | 28.6 | 91.7 (6.4) | 25.7 | |
| | Long. | 102 (3.2) | 28.6 | 95.3 (6.4) | 26.7 | |
| | AVG | 103 | 28.8 | 93.3 | 26.1 | |
| -423 | Trans. | 104 (3.2) | 29.1 | 91.6 (6.3) | 25.6 | 0.89 |
| | Trans. | 100 (3.2) | 28.0 | 89.9 (6.3) | 25.2 | |
| | Trans. | 101 (3.1) | 28.3 | 88.1 (6.3) | 24.7 | |
| | Trans. | 105 (3.2) | 29.4 | 91.1 (6.3) | 25.5 | |
| | Trans. | 104 (3.1) | 29.1 | 91.8 (6.4) | 25.7 | |
| | AVG | 103 | 28.8 | 90.5 | 25.3 | |

Table 9 (Cont)

| TEST TEMP (°F) | DIR | NOTCH T.S. (K _t =19) (KSI) | FRACTURE TOUGHNESS, K (PSI √IN.) | NOTCH/ UNNOTCH TENSILE RATIO | WELD T.S. (KSI) | WELD ELONG (%) | JOINT EFF (%) | HARDNESS (15-N) | |
|----------------------|--------|---|--|---------------------------------------|--------------------|----------------------|---------------------|--------------------------|------|
| | | | | | | | | HEAT AFFECTED ZONE | WELD |
| 78 | Long. | 62.5 (22.5) | 30.2 | | 52.6 | 4.0 | | 40 | 37 |
| | Long. | 64.6 (22.5) | 31.2 | | 57.8 | 3.0 | | 54 | 43 |
| | Long. | 66.6 (22.5) | 32.2 | | 51.7 | 2.0 | | 46 | 41 |
| | Long. | 64.1 (22.5) | 31.0 | | 57.1 | 2.0 | | 46 | 40 |
| | Long. | 65.2 (22.5) | 31.5 | | 57.7 | 2.0 | | 49 | 39 |
| | Avg | 64.6 | 31.2 | 0.90 | 55.4 | 2.6 | 77 | 47 | 40 |
| 78 | Trans. | 60.0 (21.9) | 29.0 | | 58.3 | 1.5 | | 46 | 37 |
| | Trans. | 57.7 (21.9) | 27.9 | | 57.5 | 1.5 | | 50 | 41 |
| | Trans. | 60.1 (21.9) | 29.0 | | 59.8 | 2.0 | | 46 | 36 |
| | Trans. | 61.4 (21.9) | 29.7 | | 59.0 | 2.0 | | 53 | 37 |
| | Trans. | 60.7 (21.9) | 29.3 | | 58.5 | 2.0 | | 54 | 40 |
| | Avg | 60.0 | 29.0 | 0.85 | 58.6 | 1.8 | 83 | 50 | 38 |
| -100 | Long. | 66.4 (22.5) | 32.1 | | 53.8 | 2.0 | | 52 | 42 |
| | Long. | 52.6 (22.5) | 25.4 | | 53.4 | 2.0 | | 49 | 47 |
| | Long. | 59.1 (22.5) | 28.5 | | 58.6 | 0.5 | | 46 | 36 |
| | Long. | 56.8 (22.5) | 27.4 | | 56.3 | 1.0 | | 47 | 39 |
| | Long. | 68.5 (22.5) | 33.1 | | 59.8 | 1.0 | | 43 | 39 |
| | Avg | 60.7 | 29.3 | 0.81 | 56.4 | 1.3 | 76 | 47 | 41 |
| -100 | Trans. | 51.0 (21.9) | 24.6 | | 58.0 | 2.0 | | 42 | 36 |
| | Trans. | 52.1 (21.9) | 25.2 | | 58.3 | 1.0 | | 49 | 44 |
| | Trans. | 55.2 (21.9) | 26.7 | | 57.7 | 1.5 | | 42 | 37 |
| | Trans. | 54.0 (21.9) | 26.8 | | 58.7 | 1.5 | | 49 | 39 |
| | Trans. | 57.3 (21.9) | 27.7 | | 58.2 | 1.5 | | 43 | 37 |
| | Avg | 53.9 | 26.0 | 0.73 | 58.2 | 1.5 | 79 | 45 | 39 |

| | | | | | | | |
|------|--------|-------------|------|------|-----|----|----|
| -320 | Long. | 53.9 (22.5) | 26.0 | 65.9 | 1.5 | 43 | 38 |
| | Long. | 57.5 (22.5) | 27.7 | 60.3 | 1.0 | 42 | 34 |
| | Long. | 58.0 (22.5) | 28.0 | 63.7 | 1.0 | 47 | 37 |
| | Long. | 51.4 (22.5) | 24.8 | 64.1 | 0.5 | 47 | 42 |
| | Long. | 57.9 (22.5) | 28.0 | 61.9 | 0.5 | 40 | 36 |
| | AVG | 55.7 | 26.9 | 63.2 | 0.9 | 44 | 37 |
| | | | | 0.65 | | | 75 |
| -320 | Trans. | 69.3 (21.9) | 33.5 | 65.4 | 1.0 | 49 | 39 |
| | Trans. | 62.3 (21.9) | 30.1 | 63.6 | 1.0 | 41 | 36 |
| | Trans. | 58.2 (21.9) | 28.1 | 66.9 | 1.0 | 46 | 36 |
| | Trans. | 62.8 (21.9) | 30.3 | 66.9 | 1.0 | 40 | 35 |
| | Trans. | 68.8 (21.9) | 33.2 | 65.6 | 1.0 | 46 | 37 |
| | AVG | 64.3 | 31.1 | 65.7 | 1.0 | 44 | 37 |
| | | | | 0.76 | | | 78 |
| -423 | Long. | 75.4 (22.5) | 36.4 | 71.5 | 1.5 | 48 | 32 |
| | Long. | 76.4 (22.5) | 36.9 | 71.6 | 1.5 | 45 | 43 |
| | Long. | 76.1 (22.5) | 36.8 | 62.3 | 1.5 | 50 | 37 |
| | Long. | 77.2 (22.5) | 37.3 | 69.4 | 1.0 | 41 | 36 |
| | Long. | 74.6 (22.5) | 36.0 | 79.3 | 1.0 | 46 | 37 |
| | AVG | 75.9 | 36.7 | 70.8 | 1.3 | 46 | 37 |
| | | | | 0.75 | | | 70 |
| -423 | Trans. | 81.6 (21.9) | 39.4 | 73.1 | 1.5 | 41 | 34 |
| | Trans. | 69.3 (21.9) | 33.5 | 79.1 | 1.0 | 52 | 35 |
| | Trans. | 65.5 (21.9) | 31.6 | 71.8 | 1.0 | 49 | 35 |
| | Trans. | 71.7 (21.9) | 34.6 | 70.1 | 1.5 | 41 | 35 |
| | Trans. | 69.8 (21.9) | 33.7 | 75.0 | 1.5 | 40 | 36 |
| | AVG | 71.6 | 34.6 | 73.8 | 1.3 | 45 | 35 |
| | | | | 0.70 | | | 72 |

Table 10. Properties of 5052-H38 Aluminum Alloy (0.063 In. Sheet, Aluminum Company of America, QQ-A-318)

| TEST TEMP (°F) | DIR | F _{ty} (KSI) | F _{tu} (KSI) | ELONG (%) | PROPORTIONAL LIMIT (KSI) | ELASTIC MODULUS (PSI x 10 ⁶) | HARDNESS (15-N) | |
|-------------------|--------|--------------------------|--------------------------|--------------|-----------------------------|---|--------------------|-------------------|
| | | | | | | | REDUCED SECTION | FRACTURED EDGE |
| 78 | Long. | 36.3 | 42.0 | 8.0 | 32.9 | 9.6 | 42.5 | 45.1 |
| | Long. | 36.3 | 42.0 | 8.0 | 31.4 | 10.1 | 42.3 | 42.2 |
| | Long. | 36.2 | 42.0 | 8.0 | 32.2 | 10.3 | 43.9 | 44.1 |
| | Long. | 36.5 | 42.0 | 8.0 | 31.4 | 10.1 | 43.1 | 41.0 |
| | Long. | 35.4 | 42.0 | 8.0 | 32.2 | 10.4 | 40.9 | 42.9 |
| | Avg | 36.1 | 42.0 | 8.0 | 32.0 | 10.1 | 42.5 | 43.1 |
| 78 | Trans. | 36.3 | 42.9 | 11.0 | 30.1 | 10.3 | 42.3 | 43.2 |
| | Trans. | 36.4 | 42.9 | 12.5 | 27.8 | 10.1 | 43.0 | 43.1 |
| | Trans. | 36.1 | 42.7 | 11.0 | 26.2 | 10.0 | 42.2 | 42.9 |
| | Trans. | 35.8 | 42.7 | 11.0 | 32.0 | 9.9 | 42.0 | 42.9 |
| | Trans. | 35.7 | 42.6 | 11.0 | 28.5 | 10.2 | 43.0 | 42.0 |
| | Avg | 36.1 | 42.8 | 11.3 | 28.9 | 10.1 | 42.5 | 42.8 |
| -100 | Long. | 36.8 | 43.6 | 13.0 | -- | 11.5 | 44.8 | 45.4 |
| | Long. | 36.5 | 43.6 | 10.0 | 31.0 | 10.7 | 44.7 | 46.0 |
| | Long. | 37.4 | 43.8 | 10.5 | 29.8 | 10.4 | 44.5 | 44.0 |
| | Long. | 37.8 | 43.7 | 12.5 | -- | 10.6 | 41.2 | 43.6 |
| | Long. | 37.4 | 43.8 | 13.0 | 36.2 | 10.7 | 45.2 | 42.8 |
| | Avg | 37.2 | 43.7 | 11.8 | 32.3 | 10.8 | 44.1 | 44.4 |
| -100 | Trans. | 35.6 | 42.5 | 14.0 | 32.9 | 10.1 | 43.3 | 43.0 |
| | Trans. | 37.5 | 44.5 | 14.0 | 30.8 | 10.5 | 43.3 | 43.0 |
| | Trans. | 37.7 | 44.6 | 15.0 | 33.1 | 9.9 | 43.1 | 42.1 |
| | Trans. | 37.7 | 44.6 | 14.5 | 30.9 | 11.2 | 42.9 | 44.0 |
| | Trans. | 37.7 | 44.6 | 15.0 | -- | 12.0 | 42.0 | 46.0 |
| | Avg | 37.2 | 44.2 | 14.5 | 31.9 | 10.7 | 42.9 | 43.6 |

| | | | | | | | | |
|------|--------|------|------|------|------|------|------|------|
| -320 | Long. | 43.4 | 60.7 | 28.0 | 33.6 | 12.1 | 42.5 | 46.8 |
| | Long. | 43.1 | 60.7 | 30.0 | 36.1 | 12.3 | 46.6 | 46.9 |
| | Long. | 42.9 | 60.7 | 19.5 | 33.8 | 12.6 | 45.0 | 47.1 |
| | Long. | 43.1 | 60.8 | 39.5 | 37.0 | 12.4 | 44.2 | 45.5 |
| | Long. | 43.2 | 60.8 | 19.5 | 37.7 | 12.7 | 48.8 | 47.5 |
| | Avg | 43.1 | 60.7 | 27.3 | 35.6 | 12.4 | 45.4 | 46.8 |
| -320 | Trans. | 42.4 | 56.9 | 28.5 | 36.3 | 11.6 | 42.9 | 44.7 |
| | Trans. | 42.6 | 57.0 | 29.5 | 37.7 | 11.2 | 45.9 | 47.8 |
| | Trans. | 42.9 | 57.4 | 29.0 | 37.1 | 12.8 | 44.8 | 43.4 |
| | Trans. | 41.9 | 57.2 | 30.0 | -- | 13.0 | 43.9 | 46.9 |
| | Trans. | 43.0 | 57.2 | 29.5 | 37.1 | 12.3 | 44.2 | 47.5 |
| | Avg | 42.6 | 57.1 | 29.3 | 37.1 | 12.2 | 44.3 | 46.1 |
| -423 | Long. | 52.9 | 89.5 | 21.0 | 47.2 | 12.1 | 45.9 | 48.5 |
| | Long. | 48.3 | 86.0 | 28.5 | 45.4 | 12.4 | 46.0 | 47.5 |
| | Long. | 47.5 | 86.0 | 29.0 | 47.0 | 12.3 | 46.2 | 48.1 |
| | Long. | 47.5 | 86.5 | 37.0 | 41.7 | 12.2 | 45.8 | 48.0 |
| | Long. | 47.7 | 87.8 | 37.5 | 42.7 | 13.2 | 45.4 | 47.8 |
| | Avg | 48.8 | 87.2 | 30.6 | 44.8 | 12.4 | 45.9 | 48.0 |
| -423 | Trans. | 47.7 | 76.4 | 42.0 | 39.5 | 12.4 | 46.1 | 47.4 |
| | Trans. | 47.4 | 76.1 | 41.0 | 41.1 | 12.3 | 47.0 | 48.1 |
| | Trans. | 47.7 | 76.1 | 41.5 | 38.5 | 12.2 | 45.8 | 48.0 |
| | Trans. | 47.7 | 76.1 | 42.5 | 46.0 | 12.8 | 46.1 | 48.4 |
| | Trans. | 47.8 | 76.2 | 41.0 | 45.9 | 11.9 | 46.5 | 47.1 |
| | Avg | 47.7 | 76.2 | 41.6 | 42.2 | 12.3 | 46.3 | 47.8 |

Table 10. (Cont)

| TEST TEMP (°F) | DIR | NOTCH T.S. (K _t = 6.3) (KSI) | FRACTURE TOUGHNESS, K (PSI √IN.) | NOTCH/ UNNOTCHED TENSILE RATIO | WELD T.S. (KSI) | WELD ELONG (%) | JOINT EFF (%) | HARDNESS (15-N) | |
|----------------------|--------|---|--|---|--------------------|-------------------|------------------|--------------------------|------|
| | | | | | | | | HEAT AFFECTED ZONE | WELD |
| 78 | Long. | 45.1 (6.3) | 12.6 | | 31.0 | 4.0 | | 37.0 | 20.4 |
| | Long. | 44.7 (6.3) | 12.5 | | 32.5 | 3.0 | | 41.2 | 21.5 |
| | Long. | 46.2 (6.3) | 12.9 | | 32.8 | 3.5 | | 41.0 | 24.0 |
| | Long. | 45.2 (6.3) | 12.7 | | 31.6 | 2.0 | | 38.5 | 22.3 |
| | Long. | 44.9 (6.4) | 12.6 | | 32.3 | 3.0 | | 39.4 | 24.0 |
| | Avg | 45.2 | 12.7 | 1.08 | 32.0 | 3.1 | 76 | 39.4 | 22.0 |
| 78 | Trans. | 43.6 (6.3) | 12.2 | | 33.4 | 3.5 | | 40.2 | 26.2 |
| | Trans. | 47.4 (6.3) | 13.3 | | 33.3 | 4.0 | | 37.0 | 26.2 |
| | Trans. | 47.1 (6.4) | 13.2 | | 33.4 | 3.0 | | 40.1 | 24.1 |
| | Trans. | 49.5 (6.4) | 13.9 | | 33.0 | 3.0 | | 41.6 | 19.8 |
| | Trans. | 50.1 (6.4) | 14.0 | | 33.4 | 3.0 | | 38.9 | 26.3 |
| | Avg | 47.5 | 13.3 | 1.11 | 33.3 | 3.3 | 78 | 39.6 | 24.5 |
| -100 | Long. | 46.1 (6.4) | 12.9 | | 34.2 | 4.0 | | 40.0 | 23.0 |
| | Long. | 46.6 (6.4) | 13.0 | | 34.3 | 4.0 | | 41.1 | 21.8 |
| | Long. | 46.4 (6.4) | 13.0 | | 34.1 | 4.0 | | 40.0 | 21.5 |
| | Long. | 46.6 (6.4) | 13.0 | | 34.2 | 4.0 | | 41.0 | 21.5 |
| | Long. | 46.7 (6.4) | 13.1 | | 34.4 | 4.0 | | 41.5 | 21.0 |
| | Avg | 46.5 | 13.0 | 1.06 | 34.2 | 4.0 | 78 | 40.7 | 21.8 |
| -100 | Trans. | 51.0 (6.4) | 14.3 | | 34.4 | 3.0 | | 42.0 | 25.0 |
| | Trans. | 51.2 (6.4) | 14.3 | | 34.6 | 3.0 | | 40.5 | 27.0 |
| | Trans. | 51.3 (6.4) | 14.4 | | 34.2 | 2.5 | | 40.5 | 24.4 |
| | Trans. | 51.2 (6.4) | 14.3 | | 34.6 | 4.0 | | 39.5 | 24.4 |
| | Trans. | 51.2 (6.4) | 14.3 | | 34.7 | 4.0 | | 40.0 | 26.5 |
| | Avg | 51.2 | 14.3 | 1.16 | 34.5 | 3.3 | 78 | 40.5 | 25.5 |



| | | | | | | | |
|------|--------|------------|------|------|------|------|------|
| -320 | Long. | 61.4 (6.4) | 17.2 | 49.0 | 7.5 | 41.0 | 27.6 |
| | Long. | 61.4 (6.4) | 17.2 | 46.1 | 5.0 | 41.5 | 26.5 |
| | Long. | 61.4 (6.4) | 17.2 | 41.5 | 4.0 | 39.8 | 22.0 |
| | Long. | 62.7 (6.4) | 17.6 | 49.5 | 7.5 | 43.5 | 27.5 |
| | Long. | 61.1 (6.4) | 17.1 | 50.3 | 7.5 | 40.0 | 23.5 |
| | AVG | 61.6 | 17.3 | 47.3 | 6.3 | 41.2 | 25.4 |
| | | | 1.01 | | | 78 | |
| -320 | Trans. | 63.1 (6.3) | 17.7 | 51.6 | 9.0 | 42.5 | 29.0 |
| | Trans. | 63.7 (6.3) | 17.8 | 50.7 | 9.5 | 41.5 | 29.5 |
| | Trans. | 63.7 (6.3) | 17.8 | 51.6 | 10.0 | 41.0 | 28.0 |
| | Trans. | 63.7 (6.3) | 17.8 | 50.6 | 9.0 | 43.5 | 28.0 |
| | Trans. | 63.3 (6.3) | 17.7 | 51.1 | 9.5 | 38.0 | 27.5 |
| | AVG | 63.5 | 17.8 | 51.1 | 9.4 | 41.3 | 28.4 |
| | | | 1.11 | | | 89 | |
| -423 | Long. | 76.6 (6.4) | 21.4 | 71.4 | 12.5 | 44.5 | 26.5 |
| | Long. | 76.0 (6.4) | 21.2 | 68.4 | 11.0 | 42.5 | 24.8 |
| | Long. | 77.0 (6.4) | 21.6 | 71.1 | 12.0 | 45.5 | 27.0 |
| | Long. | 78.8 (6.4) | 22.1 | 69.6 | 11.5 | 46.0 | 28.0 |
| | Long. | 76.0 (6.4) | 21.3 | 70.1 | 11.0 | 46.5 | 27.5 |
| | AVG | 76.9 | 21.5 | 70.1 | 11.6 | 44.0 | 26.8 |
| | | | 0.88 | | | 80 | |
| -423 | Trans. | 77.5 (6.3) | 21.7 | 68.4 | 14.0 | 45.0 | 31.0 |
| | Trans. | 76.0 (6.3) | 21.3 | 69.8 | 15.5 | 45.5 | 28.0 |
| | Trans. | 76.3 (6.3) | 21.4 | 68.8 | 14.0 | 46.0 | 29.0 |
| | Trans. | 79.3 (6.3) | 22.2 | 73.1 | 19.5 | 45.0 | 27.0 |
| | Trans. | 82.2 (6.3) | 23.0 | 64.2 | 12.0 | 42.5 | 22.5 |
| | AVG | 78.3 | 21.9 | 68.9 | 15.0 | 44.8 | 27.5 |
| | | | 1.03 | | | 90 | |



Table 11. Properties of 5456-H343 Aluminum Alloy (0.063 In. Sheet, Aluminum Company of America, Mil-A-19842)

| TEST TEMP (°F) | DIR | F _{ty} (KSI) | F _{tu} (KSI) | ELONG (%) | PROPORTIONAL LIMIT (KSI) | ELASTIC MODULUS (PSI x 10 ⁶) | HARDNESS (15-N) | |
|----------------|--------|-----------------------|-----------------------|-----------|--------------------------|--|-----------------|----------------|
| | | | | | | | REDUCED SECTION | FRACTURED EDGE |
| 78 | Long. | 48.2 | 56.4 | 7.0 | 36.0 | 10.2 | 51.0 | 52.0 |
| | Long. | 49.9 | 58.6 | 8.0 | 45.9 | 10.5 | 51.0 | 53.0 |
| | Long. | 49.2 | 57.5 | 7.5 | 42.0 | 10.6 | 51.3 | 52.0 |
| | Long. | 49.3 | 57.7 | 8.0 | 40.6 | 10.5 | 50.0 | 52.0 |
| | Long. | 49.4 | 57.9 | 7.5 | 34.7 | 10.5 | 52.0 | 53.0 |
| | Avg | 49.2 | 57.6 | 7.6 | 39.8 | 10.5 | 51.1 | 52.4 |
| 78 | Trans. | 43.0 | 58.4 | 9.5 | 28.7 | 10.1 | 49.5 | 50.1 |
| | Trans. | 43.2 | 58.7 | 9.5 | 29.2 | 10.2 | 52.0 | 50.1 |
| | Trans. | 43.0 | 58.4 | 10.0 | 31.0 | 10.0 | 51.5 | 52.0 |
| | Trans. | 43.3 | 58.5 | 10.0 | 29.9 | 10.1 | 51.0 | 52.0 |
| | Trans. | 43.2 | 58.1 | 9.5 | 30.0 | 10.4 | 50.0 | 51.0 |
| | Avg | 43.1 | 58.4 | 9.7 | 29.8 | 10.2 | 50.8 | 51.0 |
| -100 | Long. | 52.5 | 58.9 | 10.0 | 37.9 | 11.0 | 52.5 | 54.5 |
| | Long. | 50.4 | 58.9 | 10.0 | 43.5 | 10.8 | 53.0 | 52.8 |
| | Long. | 49.7 | 58.0 | 10.0 | 35.2 | 11.0 | 51.2 | 52.0 |
| | Long. | 50.5 | 58.2 | 10.0 | 40.2 | 10.8 | 52.0 | 53.2 |
| | Long. | 51.3 | 58.2 | 10.0 | 36.1 | 10.1 | 52.0 | 52.0 |
| | Avg | 50.9 | 58.4 | 10.0 | 38.6 | 10.7 | 52.2 | 52.9 |
| -100 | Trans. | 43.9 | 58.9 | 11.0 | 30.0 | 11.1 | 52.0 | 52.5 |
| | Trans. | 43.7 | 57.2 | 10.5 | 31.4 | 10.8 | 52.0 | 52.0 |
| | Trans. | 44.1 | 57.6 | 13.0 | 30.7 | 10.1 | 52.0 | 52.5 |
| | Trans. | 43.3 | 58.2 | 11.0 | 28.1 | 10.5 | 52.0 | 53.2 |
| | Trans. | 43.8 | 58.6 | 10.5 | 32.6 | 10.4 | 51.0 | 52.0 |
| | Avg | 43.8 | 58.1 | 11.2 | 30.6 | 10.6 | 51.8 | 52.4 |

| | | | | | | | | |
|------|--------|------|------|------|------|------|------|------|
| -320 | Long. | 58.5 | 74.7 | 12.0 | 38.3 | 10.6 | 52.0 | 52.8 |
| | Long. | 56.8 | 74.5 | 13.5 | 37.8 | 11.0 | 51.5 | 53.2 |
| | Long. | 57.6 | 76.0 | 13.0 | 41.6 | 10.3 | 53.0 | 53.1 |
| | Long. | 57.4 | 74.3 | 12.0 | 38.6 | 10.2 | 53.0 | 53.6 |
| | Long. | 57.4 | 74.4 | 12.5 | 35.7 | 10.4 | 52.0 | 52.5 |
| | Avg | 57.5 | 74.8 | 12.6 | 38.4 | 10.5 | 52.3 | 53.0 |
| -320 | Trans. | 52.0 | 72.5 | 12.0 | 45.1 | 10.9 | 51.2 | 51.5 |
| | Trans. | 52.1 | 72.7 | 13.0 | 30.0 | 10.7 | 52.1 | 54.3 |
| | Trans. | 51.3 | 72.2 | 11.5 | 44.9 | 10.0 | 52.5 | 53.5 |
| | Trans. | 50.5 | 72.0 | 12.0 | 35.8 | 10.7 | 52.0 | 52.8 |
| | Trans. | 52.6 | 72.4 | 11.5 | 43.6 | 10.8 | 52.5 | 52.8 |
| | Avg | 51.7 | 72.4 | 12.0 | 39.9 | 10.6 | 52.1 | 53.0 |
| -423 | Long. | 64.1 | 90.6 | 9.5 | 50.2 | 10.9 | 51.3 | 50.5 |
| | Long. | 63.5 | 85.3 | 8.0 | 49.0 | 11.6 | 51.0 | 52.0 |
| | Long. | 63.8 | 89.5 | 10.0 | 49.0 | 11.6 | 52.0 | 53.0 |
| | Long. | 63.8 | 87.4 | 9.0 | 42.9 | 11.1 | 53.5 | 52.6 |
| | Long. | 63.9 | 89.5 | 10.0 | 42.6 | 11.0 | 53.3 | 52.5 |
| | Avg | 63.8 | 88.5 | 9.3 | 46.7 | 11.2 | 52.2 | 52.1 |
| -423 | Trans. | 58.4 | 81.1 | 7.0 | 45.9 | 11.5 | 51.0 | 52.9 |
| | Trans. | 56.3 | 84.2 | 9.5 | 47.4 | 11.4 | 52.9 | 53.0 |
| | Trans. | 57.5 | 76.4 | 5.0 | 48.3 | 11.8 | 52.0 | 51.5 |
| | Trans. | 54.5 | 85.0 | 8.0 | 41.3 | 11.8 | 51.9 | 52.0 |
| | Trans. | 55.9 | 83.9 | 9.0 | 47.8 | 11.9 | 51.0 | 53.6 |
| | Avg | 56.5 | 82.1 | 7.7 | 46.2 | 11.7 | 51.8 | 52.6 |

Table 11. (Cont)

| TEST TEMP (°F) | DIR | NOTCH T.S. (K _t = 6.3) (KSI) | FRACTURE TOUGHNESS, K (PSI√IN.) | NOTCH/ UNNOTCH TENSILE RATIO | WELD T.S. (KSI) | WELD ELONG (%) | JOINT EFF (%) | HARDNESS (15-N) | |
|----------------------|--------|---|---------------------------------------|---------------------------------------|--------------------|----------------------|---------------------|--------------------------|------|
| | | | | | | | | HEAT AFFECTED ZONE | WELD |
| 78 | Long. | 57.6 (6.2) | 16.1 | | 52.8 | 4.5 | | 51.6 | 37.4 |
| | Long. | 56.9 (6.2) | 15.9 | | 52.8 | 5.0 | | 51.2 | 35.3 |
| | Long. | 56.6 (6.2) | 15.8 | | 53.7 | 5.0 | | 52.0 | 36.0 |
| | Long. | 56.7 (6.2) | 15.9 | | 53.3 | 5.0 | | 51.5 | 35.2 |
| | Long. | 57.0 (6.2) | 16.0 | | 52.6 | 5.0 | | 50.4 | 36.2 |
| | AVG | 57.0 | 15.9 | 0.99 | 53.0 | 4.9 | 92 | 51.3 | 36.0 |
| 78 | Trans. | 56.7 (6.6) | 15.9 | | 51.1 | 4.0 | | 48.1 | 27.9 |
| | Trans. | 56.8 (6.7) | 15.9 | | 51.5 | 4.5 | | 51.0 | 28.9 |
| | Trans. | 58.0 (6.6) | 16.2 | | 51.8 | 4.0 | | 50.0 | 31.6 |
| | Trans. | 58.0 (6.6) | 16.2 | | 51.3 | 3.5 | | 50.0 | 32.8 |
| | Trans. | 57.2 (6.6) | 16.0 | | 51.2 | 5.0 | | 49.4 | 35.7 |
| | AVG | 57.3 | 16.0 | 0.98 | 51.4 | 4.2 | 88 | 49.7 | 31.4 |
| -100 | Long. | 57.5 (6.2) | 16.1 | | 52.2 | 4.5 | | 51.6 | 39.0 |
| | Long. | 57.3 (6.2) | 16.0 | | 52.2 | 5.0 | | 52.2 | 35.0 |
| | Long. | 57.7 (6.2) | 16.2 | | 52.9 | 6.0 | | 52.2 | 34.0 |
| | Long. | 56.8 (6.3) | 15.9 | | 52.8 | 4.5 | | 52.0 | 33.1 |
| | Long. | 56.9 (6.3) | 15.9 | | 52.9 | 4.5 | | 51.4 | 34.4 |
| | AVG | 57.2 | 16.0 | 0.98 | 52.6 | 4.9 | 90 | 51.9 | 35.1 |
| -100 | Trans. | 56.7 (6.6) | 15.9 | | 48.8 | 4.5 | | 52.0 | 27.6 |
| | Trans. | 58.2 (6.6) | 16.3 | | 40.8 | 4.5 | | 51.8 | 32.8 |
| | Trans. | 57.9 (6.6) | 16.2 | | 50.4 | 4.5 | | 51.7 | 29.7 |
| | Trans. | 55.6 (6.9) | 15.6 | | 51.1 | 5.0 | | 50.2 | 35.4 |
| | Trans. | 56.1 (6.9) | 15.7 | | 50.8 | 4.5 | | 50.2 | 38.5 |
| | AVG | 56.9 | 15.9 | 0.98 | 50.4 | 4.6 | 86 | 51.2 | 32.8 |



| | | | | | | | | | |
|------|--------|------------|------|------|------|-----|----|------|------|
| -320 | Long. | 64.6 (6.3) | 18.3 | | 68.6 | 9.0 | | 50.0 | 38.5 |
| | Long. | 64.4 (6.3) | 18.0 | | 68.4 | 9.0 | | 51.0 | 32.5 |
| | Long. | 64.1 (6.3) | 18.0 | | 68.2 | 9.0 | | 52.5 | 36.4 |
| | Long. | 64.5 (6.3) | 18.1 | | 68.2 | 9.0 | | 51.5 | 36.2 |
| | Long. | 64.6 (6.3) | 18.1 | | 68.0 | 9.0 | | 51.0 | 34.4 |
| | Avg | 64.4 | 18.1 | 0.86 | 68.3 | 9.0 | 91 | 51.2 | 35.6 |
| -320 | Trans. | 60.8 (6.9) | 17.9 | | 67.1 | 9.0 | | 50.2 | 36.2 |
| | Trans. | 60.2 (6.9) | 16.9 | | 64.8 | 7.5 | | 51.2 | 36.2 |
| | Trans. | 57.2 (6.9) | 16.9 | | 65.9 | 6.5 | | 52.0 | 33.6 |
| | Trans. | 59.1 (6.9) | 16.5 | | 64.0 | 8.0 | | 51.4 | 35.8 |
| | Trans. | 59.5 (6.9) | 16.7 | | 64.7 | 6.0 | | 51.4 | 33.0 |
| | Avg | 59.4 | 16.6 | 0.82 | 65.3 | 7.4 | 90 | 51.2 | 35.0 |
| -423 | Long. | 69.5 (6.3) | 19.5 | | 66.3 | 3.5 | | 51.0 | 33.8 |
| | Long. | 67.1 (6.3) | 18.8 | | 67.5 | 2.0 | | 50.0 | 35.6 |
| | Long. | 67.4 (6.3) | 18.9 | | 66.9 | 3.0 | | 51.8 | 33.9 |
| | Long. | 69.3 (6.3) | 19.4 | | 63.7 | 1.5 | | 49.8 | 34.7 |
| | Long. | 69.4 (6.3) | 19.4 | | 67.3 | 2.5 | | 49.9 | 34.0 |
| | Avg | 68.5 | 19.2 | 0.77 | 66.3 | 2.5 | 75 | 50.5 | 34.4 |
| -423 | Trans. | 61.7 (6.9) | 17.3 | | 65.5 | 2.5 | | 46.6 | 36.0 |
| | Trans. | 61.1 (6.9) | 17.1 | | 63.8 | 3.5 | | 50.8 | 31.6 |
| | Trans. | 61.8 (6.9) | 17.3 | | 67.1 | 3.0 | | 47.9 | 33.4 |
| | Trans. | 59.9 (6.8) | 16.8 | | 65.1 | 3.0 | | 51.9 | 36.5 |
| | Trans. | 61.4 (6.8) | 17.2 | | 71.5 | 4.0 | | 48.0 | 36.5 |
| | Avg | 61.2 | 17.1 | 0.75 | 66.6 | 3.2 | 81 | 49.0 | 34.8 |

Table 12. Properties of Ti-5Al-2.5Sn Annealed (0.032 In. Sheet, TMCA, Heat No. M-8394)

| TEST TEMP (°F) | DIR | F _{ty} (KSI) | F _{tu} (KSI) | ELONG (%) | PROPORTIONAL LIMIT (KSI) | ELASTIC MODULUS (PSI x 10 ⁶) | HARDNESS (15-N) | |
|----------------------|--------|--------------------------|--------------------------|--------------|-----------------------------|--|--------------------|-------------------|
| | | | | | | | REDUCED SECTION | FRACTURED EDGE |
| 78 | Long. | 115 | 125 | 15.0 | 92.7 | 14.7 | 80.0 | 79.0 |
| | Long. | 116 | 123 | 16.5 | 93.7 | 13.9 | 80.0 | 80.0 |
| | Long. | 116 | 124 | 16.5 | 103 | 13.5 | 79.5 | 81.0 |
| | Long. | 117 | 124 | 16.5 | 96.3 | 13.9 | 79.0 | 78.0 |
| | Long. | 117 | 124 | 17.0 | 102 | 14.8 | 79.5 | 78.5 |
| | AVG | 116 | 124 | 16.3 | 97.5 | 14.2 | 79.6 | 79.3 |
| 78 | Trans. | 118 | 124 | 14.0 | 89.8 | 14.8 | 79.5 | 79.5 |
| | Trans. | 118 | 124 | 15.0 | 98.0 | 14.7 | 79.0 | 79.5 |
| | Trans. | 117 | 123 | 11.0 | 90.6 | 15.7 | 79.5 | 79.5 |
| | Trans. | 117 | 123 | 13.5 | 90.8 | 14.7 | 79.0 | 79.5 |
| | Trans. | 117 | 123 | 13.0 | 92.7 | 15.7 | 79.0 | 78.0 |
| | AVG | 117 | 123 | 13.3 | 92.4 | 15.1 | 79.2 | 79.2 |
| -100 | Long. | 142 | 145 | 12.5 | 118 | 15.8 | 79.0 | 78.5 |
| | Long. | 135 | 144 | 12.5 | 126 | 16.9 | 79.5 | 79.0 |
| | Long. | 134 | 145 | 12.5 | 125 | 15.9 | 79.5 | 80.0 |
| | Long. | 133 | 145 | 12.5 | 121 | 17.5 | 79.5 | 79.0 |
| | Long. | 129 | 144 | 14.0 | 126 | 16.8 | 79.5 | 79.5 |
| | AVG | 135 | 145 | 12.8 | 123 | 16.6 | 79.4 | 79.6 |
| -100 | Trans. | 136 | 143 | 7.5 | 127 | 18.8 | 79.0 | 79.5 |
| | Trans. | 139 | 145 | 12.5 | 127 | 18.6 | 79.5 | 79.5 |
| | Trans. | 136 | 142 | 12.0 | 129 | 16.2 | 80.0 | 79.0 |
| | Trans. | 138 | 144 | 12.0 | 125 | 16.8 | 79.0 | 79.0 |
| | Trans. | 138 | 145 | 10.0 | 127 | 18.2 | 79.0 | 79.5 |
| | AVG | 137 | 144 | 10.8 | 127 | 17.7 | 79.3 | 79.3 |

| | | | | | | | | |
|------|--------|------------|------------|-------------|------------|-------------|-------------|-------------|
| -320 | Long. | 185 | 198 | 12.0 | 173 | 16.8 | 78.0 | 79.0 |
| | Long. | 186 | 197 | 12.0 | 177 | 18.0 | 80.0 | 78.0 |
| | Long. | 185 | 197 | 12.0 | 170 | 17.6 | 80.0 | 79.5 |
| | Long. | 187 | 199 | 11.0 | 168 | 17.0 | 79.5 | 80.0 |
| | Long. | <u>187</u> | <u>199</u> | <u>12.0</u> | <u>161</u> | <u>18.7</u> | <u>79.0</u> | <u>79.0</u> |
| | AVG | 186 | 198 | 11.8 | 170 | 17.6 | 79.3 | 79.1 |
| -320 | Trans. | 188 | 197 | 9.0 | 176 | 18.0 | 77.5 | 78.0 |
| | Trans. | 187 | 197 | 7.5 | 167 | 18.0 | 79.0 | 79.0 |
| | Trans. | 187 | 198 | 5.5 | 165 | 19.0 | 78.5 | 80.5 |
| | Trans. | 197 | 210 | 11.0 | 189 | 19.4 | 78.0 | 79.0 |
| | Trans. | <u>183</u> | <u>195</u> | <u>9.0</u> | <u>162</u> | <u>17.2</u> | <u>78.5</u> | <u>79.5</u> |
| | AVG | 188 | 199 | 8.4 | 172 | 18.3 | 78.3 | 79.2 |
| -423 | Long. | 235 | 249 | 5.5 | 198 | 17.1 | 79.0 | 79.0 |
| | Long. | 233 | 249 | 5.5 | 198 | 16.9 | 79.0 | 79.5 |
| | Long. | 235 | 251 | 5.0 | 176 | 17.3 | 79.0 | 78.5 |
| | Long. | 234 | 250 | 5.0 | 185 | 19.0 | 78.5 | 78.0 |
| | Long. | <u>235</u> | <u>250</u> | <u>5.0</u> | <u>192</u> | <u>20.6</u> | <u>78.0</u> | <u>78.5</u> |
| | AVG | 234 | 250 | 5.2 | 190 | 18.2 | 78.7 | 78.7 |
| -423 | Trans. | 230 | 244 | 5.0 | 189 | 19.9 | 78.0 | 78.0 |
| | Trans. | 242 | 261 | 4.5 | 205 | 19.1 | 78.0 | 78.5 |
| | Trans. | 235 | 250 | 2.5 | 188 | 18.5 | 78.0 | 78.0 |
| | Trans. | 238 | 247 | 6.0 | 191 | 19.7 | 78.0 | 78.0 |
| | Trans. | <u>232</u> | <u>240</u> | <u>2.0</u> | <u>178</u> | <u>19.8</u> | <u>78.0</u> | <u>78.0</u> |
| | AVG | 235 | 248 | 4.0 | 190 | 19.4 | 78.0 | 78.1 |



Table 12. (Cont.)

| TEST TEMP (°F) | DIR | NOTCH T.S. (K _t (KSI)) | FRACTURE TOUGHNESS K (PSI √IN.) | NOTCH/UNNOTCH TENSILE RATIO | NOTCH T.S. (K _t (KSI)) | FRACTURE TOUGHNESS K (PSI √IN.) | NOTCH/UNNOTCH TENSILE RATIO |
|----------------|--------|-----------------------------------|---------------------------------|-----------------------------|-----------------------------------|---------------------------------|-----------------------------|
| 78 | Long. | 166 (3.2) | 46.5 | | 164 (6.4) | 45.9 | |
| | Long. | 164 (3.2) | 45.9 | | 160 (6.5) | 44.8 | |
| | Long. | 166 (3.2) | 46.5 | | 159 (6.4) | 44.5 | |
| | Long. | 166 (3.2) | 46.5 | | 164 (6.5) | 45.9 | |
| | Long. | 165 (3.2) | 46.2 | | 161 (6.5) | 45.1 | 1.31 |
| | Avg | 165 | 46.3 | 1.33 | 162 | 45.2 | |
| 78 | Trans. | 161 (3.2) | 45.1 | | 161 (6.4) | 45.1 | |
| | Trans. | 162 (3.2) | 45.4 | | 161 (6.4) | 45.1 | |
| | Trans. | 164 (3.2) | 45.9 | | 162 (6.4) | 45.4 | |
| | Trans. | 165 (3.2) | 46.2 | | 162 (6.4) | 45.4 | |
| | Trans. | 161 (3.2) | 45.1 | | 165 (6.4) | 46.2 | 1.32 |
| | Avg | 163 | 45.5 | 1.33 | 162 | 49.4 | |
| -100 | Long. | 181 (3.2) | 50.7 | | 179 (6.5) | 50.1 | |
| | Long. | 179 (3.2) | 50.1 | | 164 (6.5) | 45.9 | |
| | Long. | 180 (3.2) | 50.4 | | 178 (6.5) | 49.8 | |
| | Long. | 180 (3.2) | 50.4 | | 176 (6.5) | 49.3 | |
| | Long. | 180 (3.2) | 50.4 | | 181 (6.5) | 50.7 | 1.21 |
| | Avg | 180 | 50.4 | 1.24 | 176 | 49.2 | |
| -100 | Trans. | 179 (3.2) | 50.1 | | 174 (6.4) | 48.7 | |
| | Trans. | 181 (3.2) | 50.7 | | 176 (6.4) | 49.3 | |
| | Trans. | 181 (3.2) | 50.7 | | 178 (6.4) | 49.8 | |
| | Trans. | 181 (3.2) | 50.7 | | 178 (6.4) | 49.8 | |
| | Trans. | 180 (3.2) | 50.4 | | 182 (6.4) | 51.0 | 1.24 |
| | Avg | 180 | 50.5 | 1.25 | 178 | 49.7 | |

| | | | | | | | |
|------|--------|-----------|------|------|-----------|------|------|
| -320 | Long. | 252 (3.2) | 70.6 | 1.26 | 236 (6.5) | 66.1 | 1.20 |
| | Long. | 249 (3.2) | 69.7 | | 237 (6.5) | 66.4 | |
| | Long. | 249 (3.2) | 69.7 | | 236 (6.5) | 66.1 | |
| | Long. | 250 (3.2) | 70.0 | | 243 (6.5) | 68.0 | |
| | Long. | 249 (3.2) | 69.7 | | 232 (6.5) | 65.0 | |
| | AVG | 250 | 69.9 | 1.26 | 237 | 66.3 | 1.20 |
| -320 | Trans. | 246 (3.2) | 68.9 | | 233 (6.4) | 65.2 | |
| | Trans. | 244 (3.2) | 68.3 | | 236 (6.4) | 66.1 | |
| | Trans. | 244 (3.2) | 68.3 | | 233 (6.4) | 65.2 | |
| | Trans. | 244 (3.2) | 68.3 | | 235 (6.4) | 65.8 | |
| | Trans. | 245 (3.2) | 68.6 | | 236 (6.4) | 66.1 | |
| | AVG | 245 | 68.5 | 1.23 | 235 | 65.7 | 1.18 |
| -423 | Long. | 261 (3.2) | 73.1 | | 218 (6.5) | 61.0 | |
| | Long. | 281 (3.2) | 78.7 | | 208 (6.5) | 58.2 | |
| | Long. | 266 (3.2) | 74.5 | | 233 (6.5) | 65.2 | |
| | Long. | 275 (3.2) | 77.0 | | 211 (6.5) | 59.1 | |
| | Long. | 265 (3.2) | 74.2 | | 220 (6.5) | 61.6 | |
| | AVG | 270 | 75.5 | 1.10 | 218 | 61.0 | 0.87 |
| -423 | Trans. | 271 (3.2) | 75.9 | | 221 (6.4) | 61.9 | |
| | Trans. | 273 (3.2) | 76.4 | | 210 (6.4) | 58.8 | |
| | Trans. | 276 (3.2) | 77.3 | | 220 (6.4) | 61.6 | |
| | Trans. | 263 (3.2) | 73.6 | | 220 (6.4) | 61.6 | |
| | Trans. | 272 (3.2) | 76.2 | | 208 (6.4) | 58.2 | |
| | AVG | 271 | 75.9 | 1.10 | 216 | 60.4 | 0.87 |

Table 12. (Cont)

| TEST TEMP (°F) | DIR | NOTCH T.S. (K _t = 19) (KSI) | FRACTURE TOUGHNESS, K (PSI √IN.) | NOTCH/ UNNOTCH TENSILE RATIO | WELD T.S. (KSI) | WELD ELONG (%) | JOINT EFF (%) | HARDNESS (15-N) | |
|----------------|--------|--|----------------------------------|------------------------------|-----------------|----------------|---------------|--------------------|------|
| | | | | | | | | HEAT AFFECTED ZONE | WELD |
| 78 | Long. | 141 (21.0) | 68.1 | 1.15 | 123 | 16.5 | 99 | 79.0 | 78.5 |
| | Long. | 142 (21.0) | 68.6 | | 124 | 15.5 | | 79.5 | 78.5 |
| | Long. | 142 (21.0) | 68.6 | | 123 | 11.5 | | 79.5 | 77.5 |
| | Long. | 142 (21.0) | 68.6 | | 123 | 15.0 | | 78.5 | 77.5 |
| | Long. | 147 (21.0) | 71.0 | | 123 | 15.5 | | 79.5 | 77.5 |
| | AVG | 143 | 68.9 | | 123 | 14.8 | | 79.2 | 77.9 |
| 78 | Trans. | 145 (20.9) | 70.0 | 1.15 | 121 | 13.0 | 98 | 79.5 | 80.0 |
| | Trans. | 139 (20.9) | 67.1 | | 121 | 13.5 | | 79.0 | 77.0 |
| | Trans. | 141 (20.9) | 68.1 | | 117 | 13.0 | | 80.0 | 77.0 |
| | Trans. | 146 (20.9) | 70.5 | | 121 | 14.0 | | 79.0 | 78.0 |
| | Trans. | 140 (20.9) | 67.6 | | 121 | 13.5 | | 79.5 | 78.0 |
| | AVG | 142 | 69.7 | | 120 | 13.4 | | 79.4 | 78.0 |
| -100 | Long. | 151 (21.0) | 72.9 | 0.98 | 145 | 15.0 | 100 | 78.0 | 79.0 |
| | Long. | 126 (21.0) | 60.9 | | 145 | 12.5 | | 79.0 | 78.0 |
| | Long. | 131 (21.0) | 63.3 | | 146 | 12.5 | | 79.5 | 80.0 |
| | Long. | 153 (21.0) | 73.9 | | 147 | 16.0 | | 79.0 | 78.0 |
| | Long. | 147 (21.0) | 71.0 | | 145 | 16.0 | | 79.0 | 78.0 |
| | AVG | 142 | 68.4 | | 146 | 14.0 | | 78.9 | 78.6 |
| -100 | Trans. | 143 (20.9) | 69.1 | 1.15 | 140 | 12.5 | 99 | 78.0 | 77.0 |
| | Trans. | 137 (20.9) | 66.2 | | 143 | 12.5 | | 78.5 | 78.0 |
| | Trans. | 194 (20.9) | 93.7 | | 142 | 11.0 | | 79.5 | 77.0 |
| | Trans. | 143 (20.9) | 69.1 | | 143 | 12.5 | | 78.5 | 79.0 |
| | Trans. | 208 (20.9) | 101.0 | | 141 | 12.0 | | 79.0 | 78.0 |
| | AVG | 165 | 79.8 | | 142 | 12.1 | | 78.7 | 77.8 |



| | | | | | | | | |
|------|--------|------------|------|------|-----|------|------|------|
| -320 | Long. | 151 (21.0) | 72.9 | | 200 | 12.0 | 79.0 | 78.0 |
| | Long. | 156 (21.0) | 75.3 | | 200 | 12.5 | 78.0 | 77.0 |
| | Long. | 125 (21.0) | 60.4 | | 201 | 8.5 | 80.0 | 78.0 |
| | Long. | 131 (21.0) | 63.3 | | 201 | 13.5 | 78.0 | 78.5 |
| | Long. | 130 (21.0) | 62.8 | | 199 | 10.0 | 79.5 | 78.5 |
| | AVG | 139 | 66.9 | 0.70 | 200 | 11.3 | 78.9 | 78.0 |
| -320 | Trans. | 120 (20.9) | 58.0 | | 213 | 5.5 | 77.0 | 77.5 |
| | Trans. | 130 (20.9) | 62.8 | | 192 | 12.0 | 77.5 | 78.5 |
| | Trans. | 128 (20.9) | 61.8 | | 194 | 12.0 | 78.0 | 78.0 |
| | Trans. | 124 (20.9) | 59.9 | | 194 | 13.0 | 79.0 | 77.0 |
| | Trans. | 130 (20.9) | 62.8 | | 187 | 11.5 | 77.5 | 78.0 |
| | AVG | 126 | 61.1 | 0.63 | 196 | 10.8 | 77.8 | 77.8 |
| -423 | Long. | 122 (21.0) | 58.9 | | 245 | 5.5 | 79.0 | 78.0 |
| | Long. | 128 (21.0) | 61.8 | | 248 | 8.5 | 80.0 | 78.0 |
| | Long. | 127 (21.0) | 61.3 | | 241 | 3.5 | 77.5 | 77.5 |
| | Long. | 121 (21.0) | 58.4 | | 247 | 3.5 | 78.5 | 77.5 |
| | Long. | 122 (21.0) | 58.9 | | 244 | 2.5 | 77.0 | 78.0 |
| | AVG | 124 | 59.9 | 0.50 | 245 | 4.7 | 78.4 | 77.8 |
| -423 | Trans. | 103 (20.9) | 49.7 | | 245 | 3.0 | 78.5 | 78.0 |
| | Trans. | 113 (20.9) | 54.6 | | 244 | 4.5 | 78.0 | 77.0 |
| | Trans. | 114 (20.9) | 55.1 | | 241 | 8.0 | 77.5 | 80.5 |
| | Trans. | 113 (20.9) | 54.6 | | 241 | 3.0 | 78.0 | 77.0 |
| | Trans. | 109 (20.9) | 52.6 | | 241 | 6.5 | 78.0 | 77.5 |
| | AVG | 110 | 53.3 | 0.44 | 242 | 5.0 | 78.0 | 78.0 |

Table 13. Properties of Resistance Spot Welds of 60 Percent Cold Rolled 301 Stainless Steel, (0.025 In. Sheet, Washington Steel, Heat No. 49061, Coil No. 7450)

| TEST TEMPERATURE (°F) | TENSION/ | | TEST TEMPERATURE (°F) | TENSION/ | | TENSION/ |
|-----------------------|-----------------------|---------------------|-----------------------|-----------------------|---------------------|-------------|
| | TENSION (ULTIMATE LB) | SHEAR (ULTIMATE LB) | | TENSION (ULTIMATE LB) | SHEAR (ULTIMATE LB) | |
| | | RATIO | | | RATIO | SHEAR RATIO |
| 78 | 688 | 1060 | -100 | 600 | 1310 | |
| | 686 | 1080 | | 625 | 1305 | |
| | 694 | 1065 | | 590 | 1285 | |
| | 630 | 1035 | | 595 | 1365 | |
| | 610 | 1090 | | 625 | 1240 | |
| | 667 | 1000 | | 610 | 1330 | |
| | 620 | 1060 | | 555 | 1280 | |
| | 614 | 1060 | | 545 | 1240 | |
| | 635 | 1065 | | 585 | 1330 | |
| | 709 | 1045 | | 535 | 1305 | |
| | 655 | 1000 | | 605 | 1255 | |
| | 692 | 1015 | | 550 | 1300 | |
| | 638 | 1110 | | 590 | 1270 | |
| | 641 | 1085 | | 580 | 1285 | |
| | 642 | 1085 | | 610 | 1260 | |
| 700 | 945 | 635 | 1240 | | | |
| 678 | 1045 | 590 | 1185 | | | |
| 692 | 1080 | 600 | 1230 | | | |
| 680 | 1060 | 605 | 1300 | | | |
| 667 | 1045 | 636 | 1295 | | | |
| Average | 662 | 1052 | 593 | 1281 | 0.46 | |

| | | | | | |
|----------------|-----|------|------|-----|-------------|
| -320 | 170 | 965 | -423 | 90 | 830 |
| | 176 | 1180 | | 166 | 815 |
| | 198 | 1000 | | 165 | 818 |
| | 140 | 1000 | | 180 | 900 |
| | 196 | 1160 | | 140 | 792 |
| | 130 | 965 | | 140 | 720 |
| | 140 | 1000 | | 155 | 888 |
| | 138 | 1000 | | 150 | 807 |
| | 130 | 940 | | 115 | 863 |
| | 184 | 1125 | | 125 | 798 |
| | 178 | 970 | | 210 | 810 |
| | 155 | 1265 | | 125 | 705 |
| | 186 | 1005 | | 145 | 845 |
| | 184 | 990 | | 130 | 815 |
| | 132 | 1225 | | 127 | 895 |
| | 142 | 930 | | 93 | 820 |
| | 130 | 1010 | | 150 | 825 |
| | 138 | 985 | | 144 | 895 |
| | 182 | 1070 | | 160 | 870 |
| | 176 | 1035 | | 150 | 790 |
| Average | 160 | 1041 | | 143 | 821 |
| | | | | | <u>0.17</u> |
| | | | | | <u>0.15</u> |

Table 14. Properties of Resistance Spot Welds of 50 Percent Cold Rolled 304 ELC Stainless Steel (0.012 In. Sheet, Rodney Metals, Heat No. 33251)

| TEST TEMPERATURE (°F) | TENSION/ | | TEST TEMPERATURE (°F) | TENSION/ | |
|-----------------------|-----------------------|---------------------------|-----------------------|-----------------------|---------------------------|
| | TENSION (ULTIMATE LB) | SHEAR (ULTIMATE LB) RATIO | | TENSION (ULTIMATE LB) | SHEAR (ULTIMATE LB) RATIO |
| 78 | 260 | 400 | -100 | 243 | 535 |
| | 248 | 400 | | 222 | 520 |
| | 261 | 415 | | 236 | 545 |
| | 260 | 398 | | 240 | 555 |
| | 235 | 410 | | 238 | 535 |
| | 260 | 410 | | 244 | 550 |
| | 255 | 408 | | 280 | 510 |
| | 264 | 414 | | 246 | 525 |
| | 256 | 442 | | 212 | 475 |
| | 272 | 425 | | 250 | 485 |
| | 270 | 400 | | 252 | 450 |
| | 265 | 385 | | 224 | 495 |
| | 245 | 412 | | 244 | 480 |
| | 269 | 404 | | 250 | 485 |
| | 243 | 420 | | 280 | 440 |
| | 260 | 390 | | 254 | 470 |
| | 246 | 419 | | 246 | 520 |
| 263 | 413 | 222 | 545 | | |
| 233 | 405 | 222 | 535 | | |
| 258 | 413 | 236 | 535 | | |
| Average | 256 | 409 | 242 | 510 | |
| | | 0.63 | | 0.47 | |

| | -320 | | -423 | | |
|----------------|------|-------------|------|-----|-------------|
| | 280 | 640 | | 271 | 636 |
| | 276 | 665 | | 295 | 685 |
| | 232 | 638 | | 370 | 640 |
| | 262 | 664 | | 235 | 662 |
| | 226 | 610 | | 330 | 582 |
| | 274 | 642 | | 255 | 686 |
| | 258 | 634 | | 305 | 732 |
| | 274 | 636 | | 295 | 663 |
| | 276 | 586 | | 320 | 656 |
| | 284 | 588 | | 250 | 648 |
| | 276 | 635 | | 345 | 648 |
| | 272 | 672 | | 300 | 666 |
| | 250 | 658 | | 325 | 711 |
| | 272 | 648 | | 350 | 675 |
| | 242 | 648 | | 340 | 695 |
| | 280 | 614 | | 325 | 661 |
| | 268 | 644 | | 260 | 626 |
| | 246 | 636 | | 285 | 720 |
| | 272 | 620 | | 330 | 680 |
| | 284 | 593 | | 340 | 652 |
| Average | 265 | 634 | | 306 | 666 |
| | | <u>0.42</u> | | | <u>0.46</u> |

Contrails

Table 15. Properties of Resistance Spot Welds of 75 Percent Cold Rolled 310 Stainless Steel (0.020 In. Sheet, Washington Steel, Heat No. 43631, Coil No. 44942)

| TEST TEMPERATURE (°F) | TENSION/ | | TEST TEMPERATURE (°F) | TENSION/ | |
|-----------------------|-----------------------|---------------------------|-----------------------|-----------------------|---------------------------|
| | TENSION (ULTIMATE LB) | SHEAR (ULTIMATE LB) RATIO | | TENSION (ULTIMATE LB) | SHEAR (ULTIMATE LB) RATIO |
| 78 | 485 | 725 | -100 | 570 | 870 |
| | 521 | 720 | | 476 | 880 |
| | 514 | 725 | | 586 | 860 |
| | 516 | 770 | | 546 | 850 |
| | 519 | 775 | | 582 | 875 |
| | 497 | 725 | | 570 | 885 |
| | 505 | 725 | | 610 | 835 |
| | 508 | 735 | | 560 | 875 |
| | 511 | 745 | | 486 | 865 |
| | 507 | 740 | | 566 | 885 |
| | 507 | 755 | | 578 | 875 |
| | 509 | 770 | | 582 | 940 |
| | 490 | 800 | | 570 | 885 |
| | 531 | 730 | | 570 | 835 |
| | 534 | 735 | | 570 | 835 |
| 521 | 740 | 576 | 925 | | |
| 502 | 735 | 584 | 840 | | |
| 484 | 745 | 482 | 840 | | |
| 496 | 710 | 588 | 870 | | |
| 521 | 775 | 586 | 870 | | |
| Average | 509 | 744 | 562 | 871 | |
| | | 0.68 | | 0.65 | |

| | | | | | |
|---------|-----|------|------|-----|------|
| -320 | 614 | 1090 | -423 | 535 | 1161 |
| | 568 | 1050 | | 540 | 1193 |
| | 592 | 1115 | | 540 | 1260 |
| | 548 | 1050 | | 580 | 1365 |
| | 584 | 1070 | | 440 | 1230 |
| | 642 | 1125 | | 520 | 1165 |
| | 542 | 1090 | | 575 | 1185 |
| | 584 | 1085 | | 454 | 1270 |
| | 562 | 1130 | | 554 | 1215 |
| | 578 | 1100 | | 600 | 1250 |
| | 580 | 1070 | | 549 | 1225 |
| | 596 | 1110 | | 500 | 1175 |
| | 580 | 1150 | | 550 | 1145 |
| | 630 | 1075 | | 507 | 1270 |
| | 540 | 1050 | | 509 | 1180 |
| | 530 | 1075 | | 545 | 1270 |
| | 578 | 1130 | | 525 | 1220 |
| | 564 | 1120 | | 545 | 1215 |
| | 640 | 1115 | | 530 | 1200 |
| | 596 | 1120 | | 565 | 1290 |
| Average | 582 | 1096 | | 533 | 1224 |
| | | | | | 0.44 |
| | | | | | 0.53 |

Table 16. Properties of Resistance Spot Welds of AM-355 CRT Stainless Steel
(0.032 In. Sheet, Wallingford Steel, Heat No. 38174)

| TEST TEMPERATURE (°F) | TENSION/ | | | TEST TEMPERATURE (°F) | TENSION/ | | |
|-----------------------|-----------------------|---------------------|-------|-----------------------|-----------------------|---------------------|-------|
| | TENSION (ULTIMATE LB) | SHEAR (ULTIMATE LB) | RATIO | | TENSION (ULTIMATE LB) | SHEAR (ULTIMATE LB) | RATIO |
| 78 | 788 | 1595 | | -100 | 292 | 1685 | |
| | 849 | 1485 | | | 224 | 1855 | |
| | 905 | 1640 | | | 276 | 1545 | |
| | 880 | 1290 | | | 326 | 1765 | |
| | 830 | 1465 | | | 286 | 1615 | |
| | 814 | 1590 | | | 328 | 1815 | |
| | 860 | 1465 | | | 316 | 1785 | |
| | 845 | 1515 | | | 222 | 1770 | |
| | 715 | 1500 | | | 206 | 1970 | |
| | 930 | 1640 | | | 326 | 1705 | |
| | 846 | 1600 | | | 322 | 1840 | |
| | 876 | 1660 | | | 400 | 1755 | |
| | 887 | 1620 | | | 295 | 1660 | |
| | 865 | 1635 | | | 282 | 1770 | |
| | 933 | 1380 | | | 308 | 1820 | |
| | 848 | 1540 | | | 286 | 1705 | |
| | 840 | 1515 | | | 294 | 1720 | |
| | 822 | 1495 | | | 300 | 1635 | |
| | 849 | 1475 | | | 356 | 1890 | |
| | 835 | 1470 | | | 312 | 1860 | |
| Average | 851 | 1529 | 0.56 | | 298 | 1758 | 0.17 |

| -320 | 166 | 920 | -423 | 175 | 852 |
|----------------|------------|-------------|------|------------|-------------|
| | 172 | 922 | | 155 | 873 |
| | 186 | 874 | | 170 | 925 |
| | 186 | 960 | | 192 | 845 |
| | 178 | 858 | | 170 | 862 |
| | 198 | 890 | | 182 | 838 |
| | 192 | 906 | | 175 | 792 |
| | 186 | 912 | | 175 | 912 |
| | 178 | 900 | | 115 | 689 |
| | 180 | 776 | | 180 | 815 |
| | 190 | 940 | | 182 | 840 |
| | 184 | 922 | | 175 | 935 |
| | 200 | 886 | | 122 | 800 |
| | 198 | 948 | | 160 | 900 |
| | 184 | 910 | | 144 | 810 |
| | 188 | 926 | | 175 | 915 |
| | 172 | 890 | | 138 | 900 |
| | 198 | 912 | | 140 | 955 |
| | 192 | 880 | | 176 | 920 |
| | <u>188</u> | <u>920</u> | | <u>131</u> | <u>790</u> |
| Average | 186 | 903 | | 162 | 858 |
| | | <u>0.21</u> | | | <u>0.19</u> |

Table 17. Properties of Resistance Spot Welds of Ti-5Al-2.5Sn Alloy, Annealed
(0.032 In. Sheet, TMCA, Heat No. M8394)

| TEST TEMPERATURE (°F) | TENSION (ULTIMATE LB) | SHEAR (ULTIMATE LB) | TENSION/SHEAR RATIO | TEST TEMPERATURE (°F) | TENSION (ULTIMATE LB) | SHEAR (ULTIMATE LB) | TENSION/SHEAR RATIO |
|-----------------------|-----------------------|---------------------|---------------------|-----------------------|-----------------------|---------------------|---------------------|
| 78 | 305 | 1395 | | -100 | 256 | 1395 | |
| | 398 | 1435 | | | 208 | 1440 | |
| | 308 | 1375 | | | 280 | 1450 | |
| | 391 | 1420 | | | 256 | 1480 | |
| | 350 | 1365 | | | 272 | 1335 | |
| | 320 | 1425 | | | 278 | 1450 | |
| | 375 | 1375 | | | 234 | 1370 | |
| | 339 | 1395 | | | 248 | 1360 | |
| | 367 | 1320 | | | 276 | 1270 | |
| | 381 | 1365 | | | 222 | 1460 | |
| | 380 | 1460 | | | 306 | 1255 | |
| | 400 | 1350 | | | 242 | 1435 | |
| | 384 | 1390 | | | 210 | 1435 | |
| | 349 | 1350 | | | 286 | 1315 | |
| | 299 | 1325 | | | 238 | 1395 | |
| | 392 | 1365 | | | 292 | 1335 | |
| 335 | 1340 | | 286 | 1345 | | | |
| 367 | 1320 | | 216 | 1225 | | | |
| 396 | 1440 | | 254 | 1395 | | | |
| <u>372</u> | <u>1400</u> | | <u>260</u> | <u>1465</u> | | | |
| Average | 360 | 1381 | 0.26 | 256 | 1381 | | 0.19 |

| | | | | | |
|----------------|-----|------|------|-----|------|
| -320 | 286 | 1735 | -423 | 250 | 1710 |
| | 286 | 1660 | | 260 | 1515 |
| | 250 | 1655 | | 260 | 1500 |
| | 260 | 1735 | | 240 | 1525 |
| | 258 | 1675 | | 260 | 1640 |
| | 290 | 1750 | | 290 | 1635 |
| | 276 | 1725 | | 240 | 1540 |
| | 254 | 1725 | | 240 | 1655 |
| | 304 | 1590 | | 225 | 1600 |
| | 274 | 1620 | | 225 | 1550 |
| | 262 | 1735 | | 240 | 1475 |
| | 270 | 1695 | | 232 | 1685 |
| | 282 | 1660 | | 240 | 1630 |
| | 244 | 1585 | | 320 | 1525 |
| | 310 | 1655 | | 250 | 1535 |
| | 234 | 1655 | | 245 | 1470 |
| | 252 | 1595 | | 239 | 1700 |
| | 260 | 1615 | | 300 | 1730 |
| | 252 | 1655 | | 209 | 1625 |
| | 256 | 1685 | | 248 | 1500 |
| Average | 268 | 1670 | | 251 | 1587 |
| | | | | | 0.16 |
| | | | | | 0.16 |

Table 18. Fatigue Properties of Complex Welded Joints of 60 Percent Cold Rolled 301 Stainless Steel (0.025 In. Sheet, Washington Steel, Heat No. 49061, Coil No. 7450)

| JOINT CONFIG. | DIR | TEST TEMP (°F) | SPECIMEN NO. | STRESS RANGE (KSI) | NO. CYCLES TO FIRST LEAK | NO. CYCLES TO FAILURE | STATIC STRENGTH (KSI) | REMARKS |
|---------------|-------|----------------|--------------|--------------------|--------------------------|-----------------------|-----------------------|---------|
| 1 | Long. | 78 | 46L | ----- | --- | --- | 222 | |
| 1 | Long. | 78 | 1L | 0-150 | 600 | 987 | | |
| 1 | Long. | 78 | 2L | 0-150 | 465 | 898 | | |
| 1 | Long. | 78 | 3L | 0-150 | 500 | 968 | | |
| 1 | Long. | 78 | 4L | 0-150 | 300 | 643 | | |
| 1 | Long | 78 | 5L | 0-150 | 500 | 814 | | |
| Average | | | | | 473 | 862 | | |
| 1 | Long. | 78 | 6L | 0-170 | 400 | 581 | | |
| 1 | Long. | 78 | 7L | 0-170 | 429 | 498 | | |
| 1 | Long. | 78 | 8L | 0-170 | 350 | 599 | | |
| 1 | Long. | 78 | 9L | 0-170 | 350 | 516 | | |
| 1 | Long. | 78 | 10L | 0-170 | 350 | 528 | | |
| Average | | | | | 376 | 544 | | |
| 1 | Long. | 78 | 11L | 0-190 | 300 | 423 | | |
| 1 | Long. | 78 | 12L | 0-190 | 250 | 393 | | |
| 1 | Long. | 78 | 13L | 0-190 | 300 | 402 | | |
| 1 | Long. | 78 | 14L | 0-190 | 300 | 406 | | |
| 1 | Long. | 78 | 15L | 0-190 | 350 | 474 | | |
| Average | | | | | 300 | 420 | | |
| 2 | Long. | 78 | 66L | ----- | --- | --- | 203 | |
| 2 | Long. | 78 | 51L | 0-170 | 400 | 560 | | |
| 2 | Long. | 78 | 52L | 0-170 | 400 | 651 | | |
| 2 | Long. | 78 | 53L | 0-170 | 450 | 649 | | |
| 2 | Long. | 78 | 54L | 0-170 | 300 | 604 | | |
| 2 | Long. | 78 | 55L | 0-170 | 300 | 487 | | |
| Average | | | | | 370 | 590 | | |

Table 18 (Cont)

| JOINT CONFIG. DIR | TEST TEMP (°F) | SPECIMEN NO. | STRESS RANGE (KSI) | NO. CYCLES TO FIRST LEAK | NO. CYCLES TO FAILURE | STATIC STRENGTH (KSI) | REMARKS |
|-------------------|----------------|--------------|--------------------|--------------------------|-----------------------|-----------------------|-------------------|
| 1 | Long. | 21L | 0-214 | --- | 530 | | |
| 1 | Long. | 22L | 0-214 | --- | 418 | | |
| 1 | Long. | 23L | 0-214 | --- | 376 | | |
| 1 | Long. | 24L | 0-214 | --- | 357 | | |
| 1 | Long. | 25L | 0-214 | 300 | 350 | | |
| Average | | | | 300 | 406 | | |
| 1 | Long. | 26L | 0-239 | --- | 84 | | |
| 1 | Long. | 27L | 0-239 | --- | 68 | | |
| 1 | Long. | 28L | 0-239 | --- | 58 | | |
| 1 | Long. | 29L | 0-239 | --- | 129 | | |
| 1 | Long. | 30L | 0-239 | --- | 32 | | No leak detected. |
| Average | | | | --- | 74 | | |
| 2 | Long. | 67L | ----- | --- | | 244 | |
| 2 | Long. | 56L | 0-214 | --- | 281 | | |
| 2 | Long. | 57L | 0-214 | --- | 156 | | |
| 2 | Long. | 58L | 0-214 | --- | 103 | | |
| 2 | Long. | 59L | 0-214 | --- | 54 | | |
| 2 | Long. | 60L | 0-214 | --- | 140 | | No leak detected. |
| Average | | | | --- | 147 | | |



Table 18 (Cont)

| JOINT CONFIG. | DIR | TEST TEMP (°F) | SPECIMEN NO. | STRESS RANGE (KSI) | NO. CYCLES TO FIRST LEAK | NO. CYCLES TO FAILURE | STATIC STRENGTH (KSI) | REMARKS |
|---------------|-------|----------------|--------------|--------------------|--------------------------|-----------------------|-----------------------|-------------------|
| 1 | Long. | -423 | 36L | 0-178 | --- | 39 | | |
| 1 | Long. | -423 | 37L | 0-178 | --- | 38 | | |
| 1 | Long. | -423 | 38L | 0-178 | --- | 117 | | |
| 1 | Long. | -423 | 39L | 0-178 | --- | 21 | | |
| 1 | Long. | -423 | 40L | 0-178 | 48 | 51 | | |
| Average | | | | | 48 | 53 | | |
| 1 | Long. | -423 | 41L | 0-194 | --- | 6 | | |
| 1 | Long. | -423 | 42L | 0-199 | --- | 5 | | |
| 1 | Long. | -423 | 43L | 0-199 | --- | 3 | | |
| 1 | Long. | -423 | 44L | 0-199 | --- | 4 | | |
| 1 | Long. | -423 | 45L | 0-199 | --- | 3 | | No leak detected. |
| Average | | | | | --- | 4 | | |
| 2 | Long. | -423 | 68L | ----- | --- | --- | 214 | |
| | | | 69L | ----- | --- | --- | 207 | |
| 2 | Long. | -423 | 61L | 0-178 | --- | 19 | | |
| 2 | Long. | -423 | 62L | 0-178 | --- | 16 | | |
| 2 | Long. | -423 | 63L | 0-178 | --- | 13 | | |
| 2 | Long. | -423 | 64L | 0-178 | --- | 16 | | |
| 2 | Long. | -423 | 65L | 0-178 | --- | 19 | | No leak detected. |
| Average | | | | | --- | 17 | | |

| | | | | | | | |
|---|---------|------|-----|-------|-----|-----------|-------------------|
| 1 | Trans. | -423 | 48T | ----- | --- | --- | 168 |
| 1 | Trans. | -423 | 49T | ----- | --- | --- | 159 |
| 1 | Trans. | -423 | 31T | 0-123 | --- | 72 | |
| 1 | Trans. | -423 | 32T | 0-123 | --- | 28 | |
| 1 | Trans. | -423 | 33T | 0-123 | --- | 115 | |
| 1 | Trans. | -423 | 34T | 0-123 | --- | 106 | |
| 1 | Trans. | -423 | 35T | 0-123 | --- | 72 | |
| | Average | | | | --- | <u>79</u> | No leak detected. |
| 1 | Trans. | -423 | 36T | 0-139 | --- | 25 | |
| 1 | Trans. | -423 | 37T | 0-139 | --- | 7 | |
| 1 | Trans. | -423 | 38T | 0-139 | --- | 10 | |
| 1 | Trans. | -423 | 40T | 0-139 | --- | 12 | |
| 1 | Trans. | -423 | 50T | 0-139 | --- | 57 | |
| | Average | | | | --- | <u>22</u> | No leak detected. |
| 1 | Trans. | -423 | 41T | 0-156 | --- | 4 | |
| 1 | Trans. | -423 | 42T | 0-156 | --- | 2 | |
| 1 | Trans. | -423 | 43T | 0-156 | --- | 3 | |
| 1 | Trans. | -423 | 44T | 0-156 | --- | 3 | |
| 1 | Trans. | -423 | 45T | 0-156 | --- | 5 | |
| | Average | | | | --- | <u>3</u> | No leak detected. |

Table 19. Fatigue Properties of Complex Welded Joints of 50 Percent Cold Rolled 304 ELC Stainless Steel (0.012 In. Sheet, Rodney Metals, Heat No. 33251)

| JOINT CONFIG. | DIR | TEST TEMP (°F) | SPECIMEN NO. | STRESS RANGE (KSI) | NO. CYCLES TO FIRST LEAK | NO. CYCLES TO FAILURE | STATIC STRENGTH (KSI) | REMARKS |
|---------------|---------|----------------|--------------|--------------------|--------------------------|-----------------------|-----------------------|----------------------------|
| | | | | | | | | |
| 1 | Long. | 78 | 16L | ----- | --- | --- | 182 | |
| 1 | Long. | | 1L | 0-134 | 150 | 423 | | |
| 1 | Long. | | 2L | 0-134 | 160 | 542 | | |
| 1 | Long. | | 3L | 0-134 | 177 | 480 | | |
| 1 | Long. | | 4L | 0-134 | 200 | 610 | | |
| 1 | Long. | | 5L | 0-134 | 150 | 348 | | |
| | Average | | | | <u>167</u> | <u>481</u> | | |
| 1 | Trans. | 78 | 16T | ----- | --- | --- | 179 | Partial seam-weld failure. |
| 1 | Trans. | | 1T | 0-134 | 250 | 523 | | |
| 1 | Trans. | | 2T | 0-134 | 250 | 637 | | |
| 1 | Trans. | | 3T | 0-134 | 300 | 562 | | |
| 1 | Trans. | | 4T | 0-134 | 250 | 701 | | |
| 1 | Trans. | | 5T | 0-134 | 282 | 688 | | |
| | Average | | | | <u>266</u> | <u>622</u> | | |
| 1 | Long. | -320 | 17L | ----- | --- | --- | 235 | |
| 1 | Long. | | 6L | 0-166 | --- | 1241 | | |
| 1 | Long. | | 7L | 0-166 | --- | 1609 | | |
| 1 | Long. | | 8L | 0-166 | --- | 1237 | | |
| 1 | Long. | | 9L | 0-166 | --- | 1453 | | |
| 1 | Long. | | 10L | 0-166 | 800 | 1204 | | |
| | Average | | | | <u>800</u> | <u>1349</u> | | |

Contrails

Table 20. Fatigue Properties of Complex Welded Joints of 75 Percent Cold Rolled 310 Stainless Steel (0.020 In. Sheet, Washington Steel, Heat No. 43631, Coil No. 44942)

| JOINT CONFIG. | DIR | TEST TEMP (°F) | SPECIMEN NO. | STRESS | | NO. CYCLES TO | | STATIC STRENGTH (KSI) | REMARKS |
|---------------|---------|----------------|--------------|-------------|-----|---------------|------------|-----------------------|---------|
| | | | | RANGE (KSI) | NO. | FIRST LEAK | TO FAILURE | | |
| 1 | Long. | 78 | 46L | --- | --- | --- | --- | 187 | |
| 1 | Long. | | 1L | 0-117 | 550 | 1130 | | | |
| 1 | Long. | | 2L | 0-117 | 649 | 1220 | | | |
| 1 | Long. | | 3L | 0-117 | 560 | 1308 | | | |
| 1 | Long. | | 4L | 0-117 | 520 | 1331 | | | |
| 1 | Long. | | 5L | 0-117 | 445 | 1266 | | | |
| | Average | | | | 545 | 1251 | | | |
| 1 | Long. | 78 | 6L | 0-133 | 234 | 539 | | | |
| 1 | Long. | | 7L | 0-133 | 260 | 694 | | | |
| 1 | Long. | | 8L | 0-133 | 252 | 536 | | | |
| 1 | Long. | | 9L | 0-133 | 200 | 493 | | | |
| 1 | Long. | | 10L | 0-133 | 263 | 606 | | | |
| | Average | | | | 242 | 574 | | | |
| 1 | Long. | 78 | 11L | 0-148 | 150 | 320 | | | |
| 1 | Long. | | 12L | 0-148 | 250 | 466 | | | |
| 1 | Long. | | 13L | 0-148 | 197 | 390 | | | |
| 1 | Long. | | 14L | 0-148 | 200 | 402 | | | |
| 1 | Long. | | 15L | 0-148 | 200 | 411 | | | |
| | Average | | | | 199 | 398 | | | |
| 2 | Long. | 78 | 66L | --- | --- | --- | | 184 | |
| 2 | Long. | | 51L | 0-133 | 250 | 524 | | | |
| 2 | Long. | | 52L | 0-133 | 350 | 547 | | | |
| 2 | Long. | | 53L | 0-133 | 250 | 618 | | | |
| 2 | Long. | | 54L | 0-133 | 200 | 409 | | | |
| 2 | Long. | | 55L | 0-133 | 200 | 498 | | | |
| | Average | | | | 250 | 519 | | | |

| | | 194 | | | | | 195 | | | | |
|---|---------|-----|------|-------|------------|------------|-----|------------|------------|------------|--|
| 1 | Trans. | 78 | 46T | --- | --- | --- | --- | --- | --- | --- | |
| 1 | Trans. | | 1T | 0-117 | 415 | 764 | --- | 704 | 333 | 704 | |
| 1 | Trans. | | 2T | 0-117 | 400 | 855 | --- | 804 | 435 | 804 | |
| 1 | Trans. | | 3T | 0-117 | 450 | 802 | --- | 574 | 305 | 574 | |
| 1 | Trans. | | 4T | 0-117 | 400 | 833 | --- | 767 | 432 | 767 | |
| 1 | Trans. | | 5T | 0-117 | 500 | 840 | --- | 480 | 260 | 480 | |
| | Average | | | | <u>433</u> | <u>819</u> | | <u>666</u> | <u>353</u> | <u>666</u> | |
| 1 | Trans. | 78 | 6T | 0-133 | 240 | 413 | | 517 | 310 | 517 | |
| 1 | Trans. | | 7T | 0-133 | 300 | 456 | | 311 | 180 | 311 | |
| 1 | Trans. | | 8T | 0-133 | 300 | 505 | | 301 | 203 | 301 | |
| 1 | Trans. | | 9T | 0-133 | 250 | 549 | | 199 | 199 | 411 | |
| 1 | Trans. | | 10T | 0-133 | 250 | 493 | | 192 | 192 | 388 | |
| | Average | | | | <u>268</u> | <u>483</u> | | <u>217</u> | <u>217</u> | <u>386</u> | |
| 1 | Trans. | 78 | 11T | 0-148 | 150 | 319 | | 319 | 150 | 319 | |
| 1 | Trans. | | 12T | 0-148 | 150 | 255 | | 255 | 150 | 255 | |
| 1 | Trans. | | 13T | 0-148 | 150 | 261 | | 261 | 150 | 261 | |
| 1 | Trans. | | 14T | 0-148 | 150 | 340 | | 340 | 150 | 340 | |
| 1 | Trans. | | 15T | 0-148 | 200 | 301 | | 301 | 200 | 301 | |
| | Average | | | | <u>160</u> | <u>295</u> | | <u>295</u> | <u>160</u> | <u>295</u> | |
| 2 | Trans. | 78 | 46LT | --- | --- | --- | --- | --- | --- | --- | |
| 2 | Trans. | | 1LT | 0-117 | 333 | 704 | --- | 704 | 333 | 704 | |
| 2 | Trans. | | 2LT | 0-117 | 435 | 804 | --- | 804 | 435 | 804 | |
| 2 | Trans. | | 3LT | 0-117 | 305 | 574 | --- | 574 | 305 | 574 | |
| 2 | Trans. | | 4LT | 0-117 | 432 | 767 | --- | 767 | 432 | 767 | |
| 2 | Trans. | | 5LT | 0-117 | 260 | 480 | --- | 480 | 260 | 480 | |
| | Average | | | | <u>353</u> | <u>666</u> | | <u>666</u> | <u>353</u> | <u>666</u> | |
| 2 | Trans. | 78 | 6LT | 0-133 | 310 | 517 | | 517 | 310 | 517 | |
| 2 | Trans. | | 7LT | 0-133 | 180 | 311 | | 311 | 180 | 311 | |
| 2 | Trans. | | 8LT | 0-133 | 203 | 301 | | 301 | 203 | 301 | |
| 2 | Trans. | | 9LT | 0-133 | 199 | 411 | | 411 | 199 | 411 | |
| 2 | Trans. | | 10LT | 0-133 | 192 | 388 | | 388 | 192 | 388 | |
| | Average | | | | <u>217</u> | <u>386</u> | | <u>386</u> | <u>217</u> | <u>386</u> | |



Table 20. (Cont)

| JOINT CONFIG. | DIR | TEST TEMP (°F) | SPECIMEN NO. | STRESS RANGE (KSI) | NO. CYCLES TO FIRST LEAK | NO. CYCLES TO FAILURE | STATIC STRENGTH (KSI) | REMARKS |
|---------------|---------|----------------|--------------|--------------------|--------------------------|-----------------------|-----------------------|----------------------------------|
| 2 | Trans. | 78 | 11LT | 0-148 | 166 | 220 | | |
| 2 | Trans. | | 12LT | 0-148 | 45 | 290 | | |
| 2 | Trans. | | 13LT | 0-148 | 179 | 224 | | |
| 2 | Trans. | | 14LT | 0-148 | 168 | 266 | | |
| 2 | Trans. | | 15LT | 0-148 | 192 | 279 | | |
| | Average | | | | <u>150</u> | <u>256</u> | | |
| 1 | Long. | -320 | 47L | --- | --- | --- | 259 | |
| 1 | Long. | | 16L | 0-170 | --- | 1971 | | |
| 1 | Long. | | 17L | 0-170 | --- | 1646 | | |
| 1 | Long. | | 18L | 0-170 | --- | 2012 | | |
| 1 | Long. | | 19L | 0-170 | --- | 1146 | | |
| 1 | Long. | | 20L | 0-170 | <u>851</u> | <u>1950</u> | | |
| | Average | | | | <u>851</u> | <u>1745</u> | | |
| 1 | Long. | -320 | 21L | 0-193 | --- | 636 | | |
| 1 | Long. | | 22L | 0-193 | --- | 650 | | |
| 1 | Long. | | 23L | 0-193 | --- | 703 | | |
| 1 | Long. | | 24L | 0-193 | --- | 798 | | |
| 1 | Long. | | 25L | 0-193 | <u>401</u> | <u>664</u> | | |
| | Average | | | | <u>401</u> | <u>690</u> | | |
| 1 | Long. | -320 | 26L | 0-216 | --- | 307 | | |
| 1 | Long. | | 27L | 0-216 | --- | 292 | | |
| 1 | Long. | | 28L | 0-216 | --- | 292 | | |
| 1 | Long. | | 29L | 0-216 | --- | 296 | | |
| 1 | Long. | | 30L | 0-216 | --- | <u>321</u> | | No leaks detected at 300 cycles. |
| | Average | | | | --- | <u>302</u> | | |



| | | | | | | | | |
|---|---------|------|------|-------|------------|-----|---|--|
| 2 | Long. | -320 | 67L | --- | --- | 256 | --- | |
| 2 | Long. | | 56L | 0-193 | 573 | | | |
| 2 | Long. | | 57L | 0-193 | 722 | | | |
| 2 | Long. | | 58L | 0-193 | 485 | | | |
| 2 | Long. | | 59L | 0-193 | 583 | | | |
| 2 | Long. | | 60L | 0-193 | 476 | | | |
| | Average | | | | <u>302</u> | | | |
| | | | | | <u>302</u> | | | |
| 1 | Trans. | -320 | 47T | --- | --- | 269 | Failed in seam weld | |
| 1 | Trans. | | 16T | 0-170 | 1096 | | | |
| 1 | Trans. | | 17T | 0-170 | 1040 | | | |
| 1 | Trans. | | 18T | 0-170 | 959 | | | |
| 1 | Trans. | | 19T | 0-170 | 1217 | | | |
| 1 | Trans. | | 20T | 0-170 | 554 | | No leak detected at 550 cycles. | |
| | Average | | | | <u>973</u> | | | |
| 1 | Trans. | -320 | 21T | 0-193 | 550 | | | |
| 1 | Trans. | | 22T | 0-193 | 642 | | | |
| 1 | Trans. | | 23T | 0-193 | 613 | | | |
| 1 | Trans. | | 24T | 0-193 | 643 | | | |
| 1 | Trans. | | 25T | 0-193 | 659 | | | |
| | Average | | | | <u>619</u> | | | |
| 1 | Trans. | -320 | 26T | 0-216 | 344 | | | |
| 1 | Trans. | | 27T | 0-216 | 344 | | | |
| 1 | Trans. | | 28T | 0-216 | --- | | | |
| 1 | Trans. | | 29T | 0-216 | 381 | | Hydraulic cyl. inder froze due to night humidity. | |
| 1 | Trans. | | 30T | 0-216 | 315 | | | |
| 1 | Trans. | | 49T | 0-216 | 198 | | | |
| | Average | | | | <u>316</u> | | | |
| 2 | Trans. | -320 | 47LT | --- | --- | 270 | | |
| 2 | Trans. | | 16LT | 0-170 | 750 | | | |
| 2 | Trans. | | 17LT | 0-170 | 875 | | | |
| 2 | Trans. | | 18LT | 0-170 | 987 | | | |
| 2 | Trans. | | 19LT | 0-170 | 962 | | | |
| 2 | Trans. | | 20LT | 0-170 | 1051 | | | |
| | Average | | | | <u>925</u> | | | |



Table 20. (Cont)

| JOINT CONFIG. | DIR | TEST TEMP (°F) | SPECIMEN NO. | STRESS RANGE (KSI) | NO. CYCLES TO FIRST LEAK | NO. CYCLES TO FAILURE | STATIC STRENGTH (KSI) | REMARKS |
|---------------|---------|----------------|--------------|--------------------|--------------------------|-----------------------|-----------------------|---------------------------------|
| 2 | Trans. | -320 | 21LT | 0-193 | --- | 493 | | |
| 2 | Trans. | | 22LT | 0-193 | --- | 652 | | |
| 2 | Trans. | | 23LT | 0-193 | --- | 522 | | |
| 2 | Trans. | | 24LT | 0-193 | --- | 463 | | |
| 2 | Trans. | | 25LT | 0-193 | 250 | 404 | | |
| | Average | | | | 250 | 507 | | |
| 2 | Trans. | -320 | 26LT | 0-216 | --- | 224 | | |
| 2 | Trans. | | 27LT | 0-216 | --- | 211 | | |
| 2 | Trans. | | 28LT | 0-216 | --- | 282 | | |
| 2 | Trans. | | 29LT | 0-216 | --- | 209 | | |
| 2 | Trans. | | 30LT | 0-216 | 208 | 211 | | |
| | Average | | | | 208 | 227 | | |
| 1 | Long. | -423 | 48L | --- | --- | --- | 286 | Failed in base metal |
| 1 | Long. | | 31L | 0-199 | --- | 772 | | |
| 1 | Long. | | 32L | 0-199 | --- | 1068 | | |
| 1 | Long. | | 33L | 0-199 | --- | 616 | | |
| 1 | Long. | | 34L | 0-199 | --- | 811 | | |
| 1 | Long. | | 35L | 0-199 | 348 | 703 | | |
| | Average | | | | 348 | 794 | | |
| 1 | Long. | -423 | 36L | 0-225 | --- | 649 | | |
| 1 | Long. | | 37L | 0-225 | --- | 218 | | |
| 1 | Long. | | 38L | 0-225 | --- | 317 | | |
| 1 | Long. | | 39L | 0-225 | --- | 187 | | |
| 1 | Long. | | 40L | 0-225 | --- | 254 | | No leak detected at 250 cycles. |
| | Average | | | | --- | 325 | | |

| | | | | | | | |
|---|---------|------|-----|-------|------------|------------|-----|
| 1 | Long. | -423 | 41L | 0-252 | --- | 100 | |
| 1 | Long. | | 42L | 0-252 | --- | 109 | |
| 1 | Long. | | 43L | 0-252 | --- | 121 | |
| 1 | Long. | | 44L | 0-252 | --- | 186 | |
| 1 | Long. | | 45L | 0-252 | --- | 150 | |
| | Average | | | | --- | <u>133</u> | |
| 2 | Long. | -423 | 68L | --- | --- | --- | 282 |
| 2 | Long. | | 61L | 0-225 | --- | 201 | |
| 2 | Long. | | 62L | 0-225 | --- | 295 | |
| 2 | Long. | | 63L | 0-225 | --- | 220 | |
| 2 | Long. | | 64L | 0-225 | --- | 154 | |
| 2 | Long. | | 65L | 0-225 | --- | <u>248</u> | |
| | Average | | | | --- | <u>224</u> | |
| 1 | Trans. | -423 | 48T | --- | --- | --- | 288 |
| 1 | Trans. | | 31T | 0-199 | --- | 855 | |
| 1 | Trans. | | 32T | 0-199 | --- | 620 | |
| 1 | Trans. | | 33T | 0-199 | --- | 1002 | |
| 1 | Trans. | | 34T | 0-199 | --- | 678 | |
| 1 | Trans. | | 35T | 0-199 | 550 | 662 | |
| | Average | | | | <u>550</u> | <u>763</u> | |
| 1 | Trans. | -423 | 36T | 0-225 | --- | 240 | |
| 1 | Trans. | | 37T | 0-225 | --- | 350 | |
| 1 | Trans. | | 38T | 0-225 | --- | 330 | |
| 1 | Trans. | | 39T | 0-225 | --- | 312 | |
| 1 | Trans. | | 40T | 0-225 | 350 | 375 | |
| | Average | | | | <u>350</u> | <u>321</u> | |

Table 20. (Cont)

| JOINT CONFIG. | DIR | TEST TEMP (°F) | SPECIMEN NO. | STRESS RANGE (KSI) | NO. CYCLES TO FIRST LEAK | NO. CYCLES TO FAILURE | STATIC STRENGTH (KSI) | REMARKS |
|---------------|---------|----------------|--------------|--------------------|--------------------------|-----------------------|-----------------------|-----------------------|
| 1 | Trans. | -423 | 41T | 0-252 | --- | 75 | | Failed in base metal. |
| 1 | Trans. | | 42T | 0-252 | --- | 113 | | |
| 1 | Trans. | | 43T | 0-252 | --- | 86 | | |
| 1 | Trans. | | 44T | 0-252 | --- | 165 | | |
| 1 | Trans. | | 45T | 0-252 | --- | 88 | | No leaks detected. |
| | Average | | | | --- | 105 | | |
| 2 | Trans. | -423 | 48LT | --- | --- | --- | 298 | |
| 2 | Trans. | | 31LT | 0-199 | --- | 415 | | |
| 2 | Trans. | | 32LT | 0-199 | --- | 467 | | |
| 2 | Trans. | | 33LT | 0-199 | --- | 412 | | |
| 2 | Trans. | | 34LT | 0-199 | --- | 457 | | |
| 2 | Trans. | | 35LT | 0-199 | 450 | 511 | | |
| | Average | | | | 450 | 452 | | |
| 2 | Trans. | -423 | 36LT | 0-225 | --- | 96 | | |
| 2 | Trans. | | 37LT | 0-225 | --- | 182 | | |
| 2 | Trans. | | 38LT | 0-225 | --- | 221 | | |
| 2 | Trans. | | 39LT | 0-225 | --- | 271 | | |
| 2 | Trans. | | 40LT | 0-225 | --- | 124 | | No leaks detected. |
| | Average | | | | --- | 179 | | |
| 2 | Trans. | -423 | 41LT | 0-252 | --- | 67 | | |
| 2 | Trans. | | 42LT | 0-252 | --- | 119 | | |
| 2 | Trans. | | 43LT | 0-252 | --- | 76 | | |
| 2 | Trans. | | 44LT | 0-252 | --- | 76 | | |
| 2 | Trans. | | 45LT | 0-252 | 100 | 101 | | |
| | Average | | | | 100 | 88 | | |

Table 21. Fatigue Properties of Complex Welded Joints of AM-355 CRT Stainless Steel
(0.032 In. Sheet, Wallingford Steel, Heat No. 38174)

| JOINT CONFIG. DIR | TEST TEMP (°F) | SPECIMEN NO. | STRESS RANGE (KSI) | NO. CYCLES TO FIRST LEAK | NO. CYCLES TO FAILURE | STATIC STRENGTH (KSI) | REMARKS |
|----------------------|----------------------|-----------------|--------------------------|-----------------------------|--------------------------|-----------------------------|-------------------|
| 1 | 78 | 16L | ----- | --- | --- | 290 | |
| 1 | 78 | 1L | 0-236 | 100 | 109 | | |
| 1 | 78 | 2L | 0-236 | 100 | 164 | | |
| 1 | 78 | 3L | 0-236 | 100 | 134 | | |
| 1 | 78 | 4L | 0-236 | 100 | 144 | | |
| 1 | 78 | 5L | 0-236 | 100 | 144 | | |
| Average | | | | 100 | 139 | | |
| 2 | 78 | 36L | ----- | --- | --- | 282 | |
| 2 | 78 | 21L | 0-236 | 77 | 133 | | |
| 2 | 78 | 22L | 0-236 | 50 | 107 | | |
| 2 | 78 | 23L | 0-236 | 50 | 134 | | |
| 2 | 78 | 24L | 0-236 | 50 | 144 | | |
| 2 | 78 | 25L | 0-236 | 72 | 132 | | |
| Average | | | | 60 | 130 | | |
| 1 | 78 | 16T | ----- | --- | --- | 241 | |
| 1 | 78 | 1T | 0-213 | --- | 10 | | No leak detected. |
| 1 | 78 | 2T | 0-213 | --- | 38 | | No leak detected. |
| 1 | 78 | 3T | 0-213 | --- | 24 | | No leak detected. |
| 1 | 78 | 4T | 0-213 | --- | 5 | | No leak detected. |
| 1 | 78 | 5T | 0-213 | --- | 33 | | No leak detected. |
| Average | | | | --- | 22 | | |



Table 21 (Con't)

| JOINT CONFIG. | DIR | TEST TEMP (°F) | SPECIMEN NO. | STRESS RANGE (KSI) | NO. CYCLES TO FIRST LEAK | NO. CYCLES TO FAILURE | STATIC STRENGTH (KSI) | REMARKS |
|---------------|--------|----------------|--------------|--------------------|--------------------------|-----------------------|-----------------------|---|
| 1 | Long. | -320 | 17L | ----- | --- | --- | 148 | |
| 1 | Long. | -320 | 6L | 0-126 | --- | --- | | Failed at 124 ksi. |
| 1 | Long. | -320 | 7L | 0-126 | --- | 3 | | |
| 1 | Long. | -320 | 8L | 0-126 | --- | 4 | | |
| 1 | Long. | -320 | 9L | 0-126 | --- | 7 | | |
| 1 | Long. | -320 | 10L | 0-126 | --- | 4 | | No leak detected. |
| Average | | | | | --- | 5 | | |
| 2 | Long. | -320 | 37L | ----- | --- | --- | 132 | |
| 2 | Long. | -320 | 26L | 0-112 | --- | 19 | | |
| 2 | Long. | -320 | 27L | 0-112 | --- | 31 | | |
| 2 | Long. | -320 | 28L | 0-112 | --- | 71 | | |
| 2 | Long. | -320 | 29L | 0-112 | --- | 11 | | No leak detected. |
| 2 | Long. | -320 | 30L | 0-112 | --- | --- | | No test - failed after 7 cycles at 124 ksi. |
| Average | | | | | --- | 33 | | |
| 1 | Trans. | -320 | 17T | ----- | --- | --- | 110 | |
| 1 | Trans. | -320 | 6T | 0-94 | --- | 15 | | |
| 1 | Trans. | -320 | 7T | 0-94 | --- | 72 | | |
| 1 | Trans. | -320 | 8T | 0-94 | --- | 55 | | |
| 1 | Trans. | -320 | 9T | 0-94 | --- | 29 | | |
| 1 | Trans. | -320 | 10T | 0-94 | --- | 50 | | |
| Average | | | | | --- | 44 | | |



Table 22. Fatigue Properties of Complex Welded Joints of 2014-T6 Aluminum Alloy (0.063 In. and 0.125 In. Sheet, Aluminum Company of America, AMS-4029)

| JOINT CONFIG. | DIR | TEST TEMP (°F) | SPECIMEN NO. | STRESS RANGE (KSI) | NO. CYCLES TO FAILURE | STATIC STRENGTH (KSI) | REMARKS |
|---------------|-------|----------------|--------------|--------------------|-----------------------|-----------------------|--------------------|
| 1 | Long. | 78 | 46L | ----- | ---- | 43.7 | |
| 1 | Long. | 78 | 1L | 0-34.2 | 3065+ | | No failure. |
| 1 | Long. | 78 | 2L | 0-34.2 | 2505 | | End plate failure. |
| 1 | Long. | 78 | 3L | 0-34.2 | 2365 | | End plate failure. |
| 1 | Long. | 78 | 4L | 0-34.2 | 2373+ | | No failure. |
| 1 | Long. | 78 | 5L | 0-34.2 | 2000+ | | No failure. |
| Average | | | | | <u>2462+</u> | | |
| 1 | Long. | 78 | 6L | 0-38.8 | 2000+ | | No failure. |
| 1 | Long. | 78 | 7L | 0-38.8 | 1714 | | End plate failure. |
| 1 | Long. | 78 | 8L | 0-38.8 | 1337 | | End plate failure. |
| 1 | Long. | 78 | 9L | 0-38.8 | 1871 | | End plate failure. |
| 1 | Long. | 78 | 10L | 0-38.8 | 2020+ | | No failure. |
| Average | | | | | <u>1788+</u> | | |
| 1 | Long. | 78 | 11L | 0-43.4 | 1937 | | End plate failure. |
| 1 | Long. | 78 | 12L | 0-43.4 | 2000+ | | No failure. |
| 1 | Long. | 78 | 13L | 0-43.4 | 2076+ | | No failure. |
| 1 | Long. | 78 | 14L | 0-43.4 | 2003+ | | No failure. |
| 1 | Long. | 78 | 15L | 0-43.4 | 2000+ | | No failure. |
| Average | | | | | <u>2003+</u> | | |
| 2 | Long. | 78 | 66L | ----- | ---- | 30.9 | |
| 2 | Long. | 78 | 51L | 0-38.8 | ---- | | Failed statically. |
| 2 | Long. | 78 | 52L | 0-38.8 | 325 | | Failed in weld. |
| 2 | Long. | 78 | 53L | 0-38.8 | 14 | | Failed in weld. |
| 2 | Long. | 78 | 54L | 0-38.8 | 40 | | Failed in weld. |
| 2 | Long. | 78 | 55L | 0-38.8 | ---- | 30.9 | Failed statically. |
| Average | | | | | <u>126</u> | | |

| | | | | | | | |
|---|---------|------|-----|--------|--------------|------|-----------------|
| 1 | Trans. | 78 | 46T | ----- | ---- | 47.7 | No failure. |
| 1 | Trans. | 78 | 3T | 0-34.2 | 2000+ | | No failure. |
| 1 | Trans. | 78 | 4T | 0-34.2 | 2000+ | | No failure. |
| 1 | Trans. | 78 | 5T | 0-34.2 | 2019+ | | No failure. |
| | Average | | | | <u>2016+</u> | | |
| 1 | Trans. | 78 | 8T | 0-38.8 | 2019+ | | No failure. |
| 1 | Trans. | 78 | 9T | 0-38.8 | 2055+ | | No failure. |
| 1 | Trans. | 78 | 10T | 0-38.8 | 2055+ | | No failure. |
| | Average | | | | <u>2043+</u> | | |
| 1 | Trans. | 78 | 12T | 0-43.4 | 1134 | | Failed at weld. |
| 1 | Trans. | 78 | 13T | 0-43.4 | 2000+ | | No failure. |
| 1 | Trans. | 78 | 14T | 0-43.4 | 1683 | | Failed at weld. |
| 1 | Trans. | 78 | 15T | 0-43.4 | 2000+ | | No failure. |
| | Average | | | | <u>1704+</u> | | |
| 1 | Long. | -320 | 47L | ----- | ---- | 54.8 | No failure. |
| 1 | Long. | -320 | 16L | 0-41.2 | 2000+ | | No failure. |
| 1 | Long. | -320 | 17L | 0-41.2 | 2000+ | | No failure. |
| 1 | Long. | -320 | 18L | 0-41.2 | 2000+ | | No failure. |
| 1 | Long. | -320 | 19L | 0-41.2 | 2000+ | | No failure. |
| 1 | Long. | -320 | 20L | 0-41.2 | 2000+ | | No failure. |
| | Average | | | | <u>2000+</u> | | |
| 1 | Long. | -320 | 21L | 0-46.7 | 2000+ | | No failure. |
| 1 | Long. | -320 | 22L | 0-46.7 | 1789 | | Failed at weld. |
| 1 | Long. | -320 | 23L | 0-46.7 | 2000+ | | No failure. |
| 1 | Long. | -320 | 24L | 0-46.7 | 2000+ | | No failure. |
| 1 | Long. | -320 | 25L | 0-46.7 | 2000+ | | No failure. |
| | Average | | | | <u>1958+</u> | | |

Table 22. (Cont)

| JOINT CONFIG. | DIR | TEST TEMP (°F) | SPECIMEN NO. | STRESS RANGE (KSI) | NO. CYCLES TO FAILURE | STATIC STRENGTH (KSI) | REMARKS |
|---------------|---------|----------------|--------------|--------------------|-----------------------|-----------------------|--------------------|
| 1 | Long. | -320 | 28L | 0-52.2 | 13 | | Failed at weld. |
| 1 | Long. | -320 | 29L | 0-52.2 | 2000+ | | No failure. |
| 1 | Long. | -320 | 30L | 0-52.2 | 2000+ | | No failure. |
| | Average | | | | <u>1338+</u> | | |
| 2 | Long. | -320 | 67L | ----- | ---- | | Failed statically. |
| 2 | Long. | -320 | 56L | 0-46.7 | ---- | 45.2 | Failed statically. |
| 2 | Long. | -320 | 57L | 0-46.7 | ---- | 23.8 | Failed statically. |
| 2 | Long. | -320 | 58L | 0-46.7 | ---- | 36.8 | Failed statically. |
| 2 | Long. | -320 | 59L | 0-46.7 | ---- | 44.0 | Failed statically. |
| 2 | Long. | -320 | 60L | 0-46.7 | ---- | 39.8 | Failed statically. |
| | Average | | | | ---- | <u>37.8</u> | |
| 1 | Trans. | -320 | 47T | 0-41.2 | 2012+ | 55.3 | No failure. |
| 1 | Trans. | -320 | 16T | 0-41.2 | 2152+ | | No failure. |
| 1 | Trans. | -320 | 17T | 0-41.2 | 2000+ | | No failure. |
| 1 | Trans. | -320 | 18T | 0-41.2 | 2000+ | | No failure. |
| 1 | Trans. | -320 | 19T | 0-41.2 | 2086+ | | No failure. |
| 1 | Trans. | -320 | 20T | 0-41.2 | <u>2050+</u> | | No failure. |
| | Average | | | | | | |
| 1 | Trans. | -320 | 21T | 0-46.7 | 2000+ | | No failure. |
| 1 | Trans. | -320 | 22T | 0-46.7 | 2000+ | | No failure. |
| 1 | Trans. | -320 | 23T | 0-46.7 | 2000+ | | No failure. |
| 1 | Trans. | -320 | 24T | 0-46.7 | 2000+ | | No failure. |
| 1 | Trans. | -320 | 25T | 0-46.7 | 2074+ | | No failure. |
| | Average | | | | <u>2015+</u> | | |



| | | | | | | |
|---|---------|------|-----|--------|--------------|--------------------|
| 1 | Trans. | -320 | 26T | 0-52.2 | 2074+ | No failure. |
| 1 | Trans. | -320 | 27T | 0-52.2 | 3 | Failed in weld. |
| 1 | Trans. | -320 | 28T | 0-52.2 | 2000+ | No failure. |
| 1 | Trans. | -320 | 29T | 0-52.2 | 58 | Failed in weld. |
| 1 | Trans. | -320 | 30T | 0-52.2 | 4 | Failed in weld. |
| | Average | | | | <u>828+</u> | |
| 1 | Long. | -423 | 48L | ----- | | 71.0 |
| 1 | Long. | -423 | 31L | 0-49.9 | 2001+ | No failure. |
| 1 | Long. | -423 | 32L | 0-49.9 | 2001+ | No failure. |
| 1 | Long. | -423 | 33L | 0-49.9 | 2000+ | No failure. |
| 1 | Long. | -423 | 34L | 0-49.9 | 2000+ | No failure. |
| 1 | Long. | -423 | 35L | 0-49.9 | 2000+ | No failure. |
| | Average | | | | <u>2000+</u> | |
| 1 | Long. | -423 | 37L | 0-56.5 | 2000+ | No failure. |
| 1 | Long. | -423 | 38L | 0-56.5 | 659 | Failed in weld. |
| 1 | Long. | -423 | 39L | 0-56.5 | 2000+ | No failure. |
| 1 | Long. | -423 | 40L | 0-56.5 | 2000+ | No failure. |
| | Average | | | | <u>1665+</u> | |
| 2 | Long. | -423 | 68L | ----- | | 27.1 |
| 2 | Long. | -423 | 61L | 0-56.5 | | Failed statically. |
| 2 | Long. | -423 | 62L | 0-56.5 | | Failed statically. |
| 2 | Long. | -423 | 63L | 0-56.5 | | Failed statically. |
| 2 | Long. | -423 | 64L | 0-56.5 | | Failed statically. |
| 2 | Long. | -423 | 65L | 0-56.5 | | Failed statically. |
| | Average | | | | <u>37.7</u> | |
| 1 | Trans. | -423 | 48T | ----- | | 61.9 |
| 1 | Trans. | -423 | 31T | 0-49.9 | 2000+ | No failure. |
| 1 | Trans. | -423 | 32T | 0-49.9 | 2000+ | No failure. |
| | Average | | | | <u>2000+</u> | |

Table 23. Fatigue Properties of Complex Welded Joints of 5052-H38 Aluminum Alloy
(0.125 In. Sheet, Aluminum Company of America, QQ-A-318)

| JOINT CONFIG. | DIR | TEST | | SPECIMEN NO. | STRESS RANGE (KSI) | NO. CYCLES TO FAILURE | STATIC STRENGTH (KSI) | REMARKS |
|---------------|--------|-----------|--|--------------|--------------------|-----------------------|-----------------------|-------------|
| | | TEMP (°F) | | | | | | |
| 1 | Long. | 78 | | 16L | ----- | ----- | 30.5 | No failure. |
| 1 | Long. | 78 | | 1L | 0-26.3 | 2000+ | | No failure. |
| 1 | Long. | 78 | | 2L | 0-26.3 | 2000+ | | No failure. |
| 1 | Long. | 78 | | 3L | 0-26.3 | 2000+ | | No failure. |
| 1 | Long. | 78 | | 4L | 0-26.3 | 2000+ | | No failure. |
| 1 | Long. | 78 | | 5L | 0-26.3 | 2000+ | | No failure. |
| Average | | | | | | <u>2000+</u> | | |
| 1 | Trans. | 78 | | 16T | ----- | ----- | 31.2 | No failure. |
| 1 | Trans. | 78 | | 1T | 0-26.3 | 2041+ | | No failure. |
| 1 | Trans. | 78 | | 2T | 0-26.3 | 2000+ | | No failure. |
| 1 | Trans. | 78 | | 3T | 0-26.3 | 2000+ | | No failure. |
| 1 | Trans. | 78 | | 4T | 0-26.3 | 2000+ | | No failure. |
| 1 | Trans. | 78 | | 5T | 0-26.3 | 2000+ | | No failure. |
| Average | | | | | | <u>2008+</u> | | |
| 1 | Long. | -320 | | 17L | ----- | ----- | 49.5 | No failure. |
| 1 | Long. | -320 | | 6L | 0-42.1 | 2000+ | | No failure. |
| 1 | Long. | -320 | | 7L | 0-42.1 | 2000+ | | No failure. |
| 1 | Long. | -320 | | 8L | 0-42.1 | 2000+ | | No failure. |
| 1 | Long. | -320 | | 9L | 0-42.1 | 2000+ | | No failure. |
| 1 | Long. | -320 | | 10L | 0-42.1 | 2000+ | | No failure. |
| Average | | | | | | <u>2000+</u> | | |

| | | | | | | |
|---|---------|------|-----|--|------|-----------------|
| 1 | Trans. | -320 | 17T | ---- | 48.9 | No failure. |
| 1 | Trans. | -320 | 6T | 0-42.1 | | No failure. |
| 1 | Trans. | -320 | 7T | 0-42.1 | | No failure. |
| 1 | Trans. | -320 | 8T | 0-42.1 | | No failure. |
| 1 | Trans. | -320 | 9T | 0-42.1 | | No failure. |
| 1 | Trans. | -320 | 10T | 0-42.1 | | No failure. |
| | Average | | | 2096+ 2096+ 2134+ 2011+ 2062+ 2080+ | | |
| 1 | Long. | -423 | 18L | ---- | 58.2 | No failure. |
| 1 | Long. | -423 | 11L | 0-49.7 | | No failure. |
| 1 | Long. | -423 | 12L | 0-49.7 | | No failure. |
| 1 | Long. | -423 | 13L | 0-49.7 | | No failure. |
| 1 | Long. | -423 | 14L | 0-49.7 | | No failure. |
| 1 | Long. | -423 | 15L | 0-49.7 | | No failure. |
| | Average | | | 2000+ 2000+ 2000+ 2000+ 2000+ 2000+ | | |
| 1 | Trans. | -423 | 18T | ---- | 58.8 | Failed at weld. |
| 1 | Trans. | -423 | 11T | 0-49.7 | | Failed at weld. |
| 1 | Trans. | -423 | 12T | 0-49.7 | | No failure. |
| 1 | Trans. | -423 | 13T | 0-49.7 | | No failure. |
| 1 | Trans. | -423 | 14T | 0-49.7 | | No failure. |
| 1 | Trans. | -423 | 15T | 0-49.7 | | Failed at weld. |
| | Average | | | 1167 1926 2000+ 2000+ 1867 1792 | | |

Table 24. Fatigue Properties of Complex Welded Joints of 5456-H343 Aluminum Alloy (0.063 In. and 0.125 In. Sheet, Aluminum Company of America, Mil-A-19842)

| JOINT CONFIG. | DIR | TEST TEMP (°F) | SPECIMEN NO. | STRESS RANGE (KSI) | NO. CYCLES TO FAILURE | STATIC | | REMARKS |
|---------------|--------|----------------|--------------|--------------------|-----------------------|----------------|----------------------|----------------------|
| | | | | | | STRENGTH (KSI) | STRENGTH (KSI) | |
| 1 | Long. | 78 | 16L | ----- | ---- | - | | |
| | | | 2L | 0-42.5 | 2000+ | | No. failure. | |
| | | | 3L | 0-42.5 | 2000+ | | No. failure. | |
| | | | 4L | 0-42.5 | 2000+ | | No. failure. | |
| | | | 5L | 0-42.5 | 2000+ | | No. failure. | |
| Average | | | | | | | | |
| 2 | Long. | 78 | 21L | ----- | -- | 32.9 | | Failed in weld. |
| | | | 22L | 0-30.0 | 1 | | Failed in weld. | |
| | | | 23L | 0-30.0 | 58 | | Failed in weld. | |
| | | | 24L | 0-30.0 | 5 | | Failed in weld. | |
| | | | 25L | 0-30.0 | 96 | | Failed in weld. | |
| | | | Average | | | | 40 | |
| 1 | Trans. | 78 | 16T | 0-42.5 | 1109 | 48.0 | | Failed in end plate. |
| | | | 1T | 0-42.5 | 1177 | | Failed in end plate. | |
| | | | 2T | 0-42.5 | 2000+ | | No failure. | |
| | | | 3T | 0-42.5 | 2000+ | | No failure. | |
| | | | 4T | 0-42.5 | 2000+ | | No failure. | |
| | | | Average | | | | 1657+ | |
| 1 | Long. | -320 | 17L | ----- | ---- | 63.2 | | No failure. |
| | | | 6L | 0-53.7 | 2000+ | | Failed in weld. | |
| | | | 7L | 0-53.7 | 1594 | | Failed in weld. | |
| | | | 8L | 0-53.7 | 1826 | | Failed in weld. | |
| | | | 9L | 0-53.7 | 1800 | | Failed in weld. | |
| | | | Average | | | | 1105 | |
| | | | | | 1665+ | | | |

| | | | | | | | |
|---------|--------|------|-----|--------|--------------|-------------|----------------------|
| 2 | Long. | -320 | 26L | 0-53.7 | - | 45.2 | Failed statically. |
| 2 | Long. | -320 | 27L | 0-53.7 | - | 36.6 | Failed statically. |
| 2 | Long. | -320 | 28L | 0-53.7 | - | 35.6 | Failed statically. |
| 2 | Long. | -320 | 29L | 0-53.7 | - | 39.6 | Failed statically. |
| 2 | Long. | -320 | 30L | 0-53.7 | - | 36.5 | Failed statically. |
| Average | | | | | | <u>38.8</u> | |
| 1 | Trans. | -320 | 17T | ----- | ---- | 59.9+ | Failed in end plate. |
| 1 | Trans. | -320 | 6T | 0-53.7 | 2255 | | Failed in weld. |
| 1 | Trans. | -320 | 7T | 0-53.7 | 1567 | | Failed in weld. |
| 1 | Trans. | -320 | 8T | 0-53.7 | 2000+ | | No failure. |
| 1 | Trans. | -320 | 9T | 0-53.7 | 766 | | Failed in weld. |
| 1 | Trans. | -320 | 10T | 0-53.7 | 2000+ | | No failure. |
| Average | | | | | <u>1718+</u> | | |
| 1 | Long. | -423 | 18L | ----- | - | 55.8 | No failure. |
| 1 | Long. | -423 | 11L | 0-47.9 | 2000+ | | No failure. |
| 1 | Long. | -423 | 12L | 0-47.9 | 2000+ | | No failure. |
| 1 | Long. | -423 | 13L | 0-47.9 | 2073+ | | No failure. |
| 1 | Long. | -423 | 14L | 0-47.9 | 2173+ | | No failure. |
| 1 | Long. | -423 | 15L | 0-47.9 | 1652 | | Failed in weld. |
| Average | | | | | <u>1980+</u> | | |
| 2 | Long. | -423 | 31L | ----- | --- | 36.6 | Failed in weld. |
| 2 | Long. | -423 | 32L | 0-31.2 | 938 | | Failed in weld. |
| 2 | Long. | -423 | 33L | 0-31.2 | 1639 | | No failure. |
| 2 | Long. | -423 | 34L | 0-31.2 | <u>2000+</u> | | |
| Average | | | | | <u>1526+</u> | | |
| 1 | Trans. | -423 | 18T | ----- | - | 56.6 | No failure. |
| 1 | Trans. | -423 | 11T | 0-47.9 | 2000+ | | No failure. |
| 1 | Trans. | -423 | 12T | 0-47.9 | 2000+ | | No failure. |
| 1 | Trans. | -423 | 13T | 0-47.9 | 2000+ | | No failure. |
| 1 | Trans. | -423 | 14T | 0-47.9 | 2000+ | | No failure. |
| 1 | Trans. | -423 | 15T | 0-47.9 | <u>2000+</u> | | No failure. |
| Average | | | | | <u>2000+</u> | | |

Table 25. Fatigue Properties of Complex Welded Joints of Ti-5AL-2.5Sn Alloy
(0.032 In. Sheet, TMCA, Heat No. M-8394, Mill annealed)

| JOINT CONFIG. | DIR | TEST TEMP (°F) | SPECIMEN NO. | STRESS | | NO. CYCLES TO NO. CYCLES TO FAILURE | NO. CYCLES TO FAILURE | STATIC STRENGTH (KSI) | REMARKS |
|---------------|-------|----------------|--------------|-------------|------------|-------------------------------------|-----------------------|-----------------------|---------------------------------|
| | | | | RANGE (KSI) | FIRST LEAK | | | | |
| 1 | Long. | 78 | 46L | ---- | ---- | ---- | ---- | 120 | |
| 1 | Long. | 78 | 1L | 0-87 | 1100 | 1827 | | | |
| 1 | Long. | 78 | 2L | 0-87 | 1093 | 1773 | | | |
| 1 | Long. | 78 | 3L | 0-87 | 700 | 1164 | | | |
| 1 | Long. | 78 | 4L | 0-87 | 704 | 1483 | | | |
| 1 | Long. | 78 | 5L | 0-87 | 950 | 1772 | | | |
| Average | | | | | 909 | 1604 | | | |
| 1 | Long. | 78 | 6L | 0-99 | 600 | 902 | | | |
| 1 | Long. | 78 | 7L | 0-99 | 1250 | 1531 | | | |
| 1 | Long. | 78 | 8L | 0-99 | 650 | 847 | | | |
| 1 | Long. | 78 | 9L | 0-99 | 400 | 520 | | | |
| 1 | Long. | 78 | 10L | 0-99 | 500 | --- | | | Failed in radius at 508 cycles. |
| 1 | Long. | 78 | 49L | 0-99 | 600 | 949 | | | |
| Average | | | | | 800 | 950 | | | |
| 1 | Long. | 78 | 11L | 0-110 | 300 | 455 | | | |
| 1 | Long. | 78 | 12L | 0-110 | 300 | 388 | | | |
| 1 | Long. | 78 | 13L | 0-110 | 272 | 323 | | | |
| 1 | Long. | 78 | 14L | 0-110 | 500 | 564 | | | |
| 1 | Long. | 78 | 15L | 0-110 | 350 | 468 | | | |
| Average | | | | | 344 | 440 | | | |
| 2 | Long. | 78 | 51L | 0-99 | --- | 584 | | | |
| 2 | Long. | 78 | 52L | 0-99 | --- | 556 | | | |
| 2 | Long. | 78 | 53L | 0-99 | 200 | 456 | | | |
| 2 | Long. | 78 | 54L | 0-99 | 184 | 639 | | | |
| Average | | | | | 192 | 549 | | | |

| | | | | | | | | |
|---|---------|------|-----|-------|-------|-------|-------|-------------------------------|
| 3 | Long. | 78 | 75L | 0-99 | 2000+ | 2000+ | 2000+ | No leaks or failure. |
| 3 | Long. | 78 | 76L | 0-99 | 2000+ | 2000+ | 2000+ | No leaks or failure. |
| | Average | | | | 2000+ | 2000+ | 2000+ | |
| 3 | Long. | 78 | 77L | 0-110 | --- | 566 | 566 | Failed in weld. |
| 3 | Long. | 78 | 78L | 0-110 | ----- | 507+ | 507+ | No failure, specimen yielded. |
| | Average | | | | ----- | 537+ | 537+ | |
| 1 | Trans. | 78 | 1T | 0-87 | 708 | 883 | 883 | |
| 1 | Trans. | 78 | 2T | 0-87 | 700 | 937 | 937 | |
| 1 | Trans. | 78 | 3T | 0-87 | 850 | 1294 | 1294 | |
| 1 | Trans. | 78 | 4T | 0-87 | 850 | 1205 | 1205 | |
| 1 | Trans. | 78 | 5T | 0-87 | 850 | 1645 | 1645 | |
| | Average | | | | 792 | 1187 | 1187 | |
| 1 | Trans. | 78 | 46T | | --- | --- | --- | 112 |
| 1 | Trans. | 78 | 6T | 0-99 | 500 | 729 | 729 | |
| 1 | Trans. | 78 | 7T | 0-99 | 350 | 672 | 672 | |
| 1 | Trans. | 78 | 8T | 0-99 | 300 | 560 | 560 | |
| 1 | Trans. | 78 | 9T | 0-99 | 300 | 461 | 461 | |
| 1 | Trans. | 78 | 10T | 0-99 | 400 | 430 | 430 | |
| | Average | | | | 370 | 570 | 570 | |
| 1 | Trans. | 78 | 11T | 0-110 | 400 | 633 | 633 | |
| 1 | Trans. | 78 | 12T | 0-110 | 450 | 570 | 570 | |
| 1 | Trans. | 78 | 13T | 0-110 | 350 | 489 | 489 | |
| 1 | Trans. | 78 | 14T | 0-110 | 350 | 605 | 605 | |
| | Average | | | | 370 | 574 | 574 | |
| 1 | Long. | -320 | 47L | | --- | --- | --- | 188 |
| 1 | Long. | -320 | 16L | 0-140 | --- | 516 | 516 | |
| 1 | Long. | -320 | 17L | 0-140 | --- | 425 | 425 | |
| 1 | Long. | -320 | 18L | 0-140 | --- | 299 | 299 | |
| 1 | Long. | -320 | 19L | 0-140 | --- | 168 | 168 | |
| 1 | Long. | -320 | 20L | 0-140 | 150 | 167 | 167 | |
| | Average | | | | 150 | 315 | 315 | |

Table 25 (Cont)

| JOINT CONFIG. | DIR | TEST TEMP (°F) | SPECIMEN NO. | STRESS | | NO. CYCLES TO NO. FIRST LEAK | NO. CYCLES TO FAILURE | STATIC STRENGTH (KSI) | REMARKS |
|---------------|-------|----------------|--------------|-------------|-------------|------------------------------|-----------------------|-----------------------|----------------------|
| | | | | RANGE (KSI) | RANGE (KSI) | | | | |
| 1 | Long. | -320 | 21L | 0-159 | --- | --- | 39 | | |
| 1 | Long. | -320 | 22L | 0-159 | --- | --- | 45 | | |
| 1 | Long. | -320 | 23L | 0-159 | --- | --- | 51 | | |
| 1 | Long. | -320 | 24L | 0-159 | --- | --- | 79 | | |
| 1 | Long. | -320 | 25L | 0-159 | --- | --- | 73 | | No leak detected. |
| Average | | | | | --- | --- | <u>57</u> | | |
| 1 | Long. | -320 | 26L | 0-178 | --- | --- | 6 | | |
| 1 | Long. | -320 | 27L | 0-178 | --- | --- | 6 | | |
| 1 | Long. | -320 | 28L | 0-178 | --- | --- | 8 | | |
| 1 | Long. | -320 | 29L | 0-178 | --- | --- | 8 | | |
| 1 | Long. | -320 | 30L | 0-178 | --- | --- | 19 | | No leak detected. |
| Average | | | | | --- | --- | <u>9</u> | | |
| 2 | Long. | -320 | 67L | | --- | --- | --- | | |
| 2 | Long. | -320 | 56L | 0-159 | --- | --- | 107 | | |
| 2 | Long. | -320 | 57L | 0-159 | --- | --- | 108 | | |
| 2 | Long. | -320 | 58L | 0-159 | --- | --- | 169 | | |
| 2 | Long. | -320 | 59L | 0-159 | --- | --- | 134 | | |
| 2 | Long. | -320 | 60L | 0-159 | --- | --- | 122 | | |
| Average | | | | | --- | --- | <u>128</u> | | |
| 3 | Long. | -320 | 79L | 0-159 | --- | --- | 2000+ | | No failure. |
| 3 | Long. | -320 | 80L | 0-159 | --- | --- | 2000+ | | No failure. |
| 3 | Long. | -320 | 81L | 0-159 | --- | --- | 1878 | | Failed in end plate. |
| Average | | | | | --- | --- | <u>1959+</u> | | |
| 3 | Long. | -320 | 82L | 0-178 | --- | --- | 956 | | Failed in end plate. |
| 3 | Long. | -320 | 83L | 0-178 | --- | --- | 704 | | Failed in end plate. |
| 3 | Long. | -320 | 84L | 0-178 | --- | --- | 468 | | Failed in end plate. |
| Average | | | | | --- | --- | <u>709</u> | | |



| | | | | | | | |
|---|---------|------|-----|------|------|-----|----------------------|
| 1 | Trans. | -320 | 47T | ---- | -- | 164 | |
| 1 | Trans. | -320 | 21T | ---- | 9 | | |
| 1 | Trans. | -320 | 22T | ---- | 38 | | |
| 1 | Trans. | -320 | 23T | ---- | -- | 154 | Failed on loading. |
| 1 | Trans. | -320 | 24T | ---- | -- | 157 | Failed on loading. |
| 1 | Trans. | -320 | 25T | ---- | -- | 157 | Failed on loading. |
| | Average | | | ==== | 24 | 158 | |
| 1 | Long. | -423 | 48L | ---- | ---- | 172 | |
| 1 | Long. | -423 | 31L | ---- | 596 | | |
| 1 | Long. | -423 | 32L | ---- | 600 | | |
| 1 | Long. | -423 | 33L | ---- | 245 | | |
| 1 | Long. | -423 | 34L | ---- | 158 | | |
| 1 | Long. | -423 | 35L | ---- | ---- | 172 | Error in test-failed |
| 1 | Long. | -423 | 50L | ---- | 1714 | 172 | statically. |
| | Average | | | ==== | 663 | 172 | |
| 1 | Long. | -423 | 36L | ---- | 91 | | |
| 1 | Long. | -423 | 37L | ---- | 58 | | |
| 1 | Long. | -423 | 38L | ---- | 83 | | |
| 1 | Long. | -423 | 39L | ---- | 8 | | |
| 1 | Long. | -423 | 40L | ---- | 34 | | |
| | Average | | | ==== | 55 | | No leak detected. |
| 1 | Long. | -423 | 41L | ---- | 8 | | |
| 1 | Long. | -423 | 42L | ---- | 3 | | |
| 1 | Long. | -423 | 43L | ---- | -- | 160 | Failed on loading. |
| 1 | Long. | -423 | 44L | ---- | -- | 162 | Failed on loading. |
| 1 | Long. | -423 | 45L | ---- | 8 | | No leak detected. |
| 1 | Long. | -423 | LX1 | ---- | 26 | | |
| | Average | | | ==== | 11 | 161 | |
| 2 | Long. | -423 | 61L | ---- | ---- | | Error in load. |
| 2 | Long. | -423 | 62L | ---- | 240 | | |
| | Average | | | ==== | 240 | | |

Table 25 (Cont)

| JOINT CONFIG. | DIR | TEST TEMP (°F) | SPECIMEN NO. | STRESS RANGE (KSI) | NO. CYCLES TO FIRST LEAK | NO. CYCLES TO FAILURE | STATIC STRENGTH (KSI) | REMARKS |
|---------------|--------|----------------|--------------|--------------------|--------------------------|-----------------------|-----------------------|----------------------------|
| | | | | | | | | |
| 3 | Long. | -423 | 85L | 0-184 | ---- | ---- | | Failed in base metal. (35) |
| 3 | Long. | -423 | 86L | 0-184 | ---- | 1054 | | Failed in end plate. |
| 3 | Long. | -423 | 87L | 0-184 | ---- | 220 | | Failed in weld. |
| Average | | | | | | <u>637</u> | | |
| 3 | Long. | -423 | 88L | 0-208 | ---- | 446 | | Failed in end plate. |
| 3 | Long. | -423 | 89L | 0-208 | ---- | 846 | | Failed in weld. |
| 3 | Long. | -423 | 90L | 0-208 | ---- | 409 | | Failed in end plate. |
| Average | | | | | | <u>567</u> | | |
| 1 | Trans. | -423 | 48T | ---- | ---- | - | 159 | |
| 1 | Trans. | -423 | 36T | 0-146 | ---- | 6 | | |
| 1 | Trans. | -423 | 37T | 0-146 | ---- | 7 | | |
| 1 | Trans. | -423 | 38T | 0-146 | ---- | 2 | | |
| 1 | Trans. | -423 | 39T | 0-146 | ---- | 2 | | |
| 1 | Trans. | -423 | 40T | 0-146 | ---- | 4 | | No leaks detected. |
| Average | | | | | | <u>4</u> | | |

Table 26. Properties of 60 Percent Cold Rolled 301 Stainless Steel (0.010 In. Sheet, Heat No. 57644, Coil No. 11976) *

| TEST TEMP (°F) | DIR | F _{ty} (KSI) | F _{tu} (KSI) | ELONG (%) | NOTCH T.S. (KSI) | NOTCH/UNNOTCH TENSILE RATIO (K _t =6.3) | WELD T.S. (KSI) | JOINT EFF (%) | STRESS (KSI) | CYCLES TO LEAK | CYCLES TO FAILURE | FATIGUE (JOINT CONFIG. NO. 1) |
|----------------|--------|-----------------------|-----------------------|-----------|------------------|---|-----------------|---------------|--------------|----------------|-------------------|-------------------------------|
| | | | | | | | | | | | | |
| 78 | Long. | 192 | 204 | 5.0 | 220 | | 208 | | 0-140 | 124 | 347 | |
| | Long. | 190 | 203 | 5.0 | 221 | | 208 | | 0-140 | 127 | 489 | |
| | Long. | 191 | 207 | 6.5 | 222 | | - | | ----- | --- | --- | |
| | Long. | 190 | 207 | 6.5 | 220 | | - | | ----- | --- | --- | |
| | Long. | 193 | 209 | 9.5 | 219 | | - | | ----- | --- | --- | |
| | Long. | 192 | 202 | 4.0 | 217 | | - | | ----- | --- | --- | |
| | Long. | 196 | 208 | 9.0 | - | | - | | ----- | --- | --- | |
| | Long. | 192 | 204 | 4.0 | - | | - | | ----- | --- | --- | |
| | AVG. | 192 | 206 | 6.2 | 220 | 1.07 | 208 | 100 | 0-140 | 126 | 418 | |
| | Trans. | 171 | 219 | 7.0 | 221 | | 189 | | | | | |
| -423 | Long. | 240 | 281 | ---- | 273 | | 258 | | 0-140 | 300 | 555 | |
| | Long. | 271 | 302 | 12.0 | 290 | | 248 | | 0-140 | 250 | 423 | |
| | Long. | 282 | 305 | 14.0 | 294 | | 264 | | 0-140 | 300 | 462 | |
| | Long. | 294 | 304 | 3.0 | 298 | 0.99 | --- | 89 | 0-140 | 200 | 498 | |
| | Long. | --- | 301 | 3.0 | 278 | | --- | | 0-140 | 300 | 827 | |
| | Long. | 245 | 298 | 1.0 | 294 | | --- | | ----- | --- | --- | |
| | Long. | 248 | 288 | 2.0 | --- | | --- | | ----- | --- | --- | |
| | Long. | 271 | 292 | 4.0 | --- | | --- | | ----- | --- | --- | |
| | AVG. | 264 | 296 | 5.3 | 288 | 0.97 | 257 | 87 | 0-140 | 270 | 553 | |
| | Trans. | 237 | 297 | 6.5 | 276 | | 239 | | | | | |
| -423 | Trans. | 232 | 308 | 6.0 | 245 | | 261 | | | | | |
| | Trans. | 270 | 320 | 8.5 | 238 | | 228 | | | | | |
| | AVG. | 246 | 308 | 7.0 | 253 | 0.82 | 243 | 79 | | | | |

* Chemistry: Cr-17.38, Ni-7.32, Mn-1.04, C-0.09.

Table 27. Properties of Annealed Ti-5Al-2.5Sn Alloy (0.014 In. Sheet, Republic Steel Co...
Heat No. 3930131, Specification GD/A-0-71010)

| TEST TEMP (°F) | DIR. | F _{ty} (KSI) | F _{tu} (KSI) | ELONG (%) | NOTCH T.S. (K _t = 6.3) (KSI) | NOTCH/UNNOTCH TENSILE RATIO | WELD T.S. (KSI) | WELD ELONG (%) | JOINT EFF (%) |
|----------------|--------|-----------------------|-----------------------|-----------|---|-----------------------------|-----------------|----------------|---------------|
| 78 | Long. | 114 | 125 | 16.0 | 165 | | 116 | 2.0 | |
| | Long. | 116 | 128 | 17.0 | 166 | | 111 | 1.0 | |
| | Long. | 118 | 127 | 14.5 | 167 | | 116 | 2.0 | |
| | Long. | 118 | 128 | 14.5 | 170 | | 114 | 1.5 | |
| | Long. | 120 | 128 | 14.5 | 170 | | 114 | 2.0 | |
| | AVG. | 117 | 127 | 15.3 | 168 | 1.32 | 114 | 1.7 | 90 |
| 78 | Trans. | 118 | 126 | 13.5 | 168 | | 118 | 2.0 | |
| | Trans. | 118 | 125 | 12.5 | 168 | | 116 | 1.5 | |
| | Trans. | 119 | 126 | 14.5 | 166 | | 120 | 2.0 | |
| | Trans. | 118 | 126 | 14.0 | 167 | | 118 | 1.5 | |
| | Trans. | 118 | 125 | 14.0 | 169 | | 113 | 1.0 | |
| | AVG. | 118 | 126 | 13.7 | 168 | 1.33 | 117 | 1.6 | 93 |
| -320 | Long. | 175 | 188 | 18.5 | 233 | | 181 | 2.0 | |
| | Long. | 173 | 187 | 18.5 | --- | | 184 | 2.0 | |
| | Long. | 176 | 189 | 17.5 | --- | | 188 | 3.0 | |
| | Long. | 176 | 189 | 18.5 | --- | | 180 | 1.5 | |
| | Long | 175 | 190 | 18.5 | --- | | 180 | 1.5 | |
| | AVG. | 175 | 189 | 18.3 | 233 | 1.23 | 183 | 2.0 | 97 |

| | | | | | | | | | |
|------|--------|-----|-----|-------|-----|------|-----|-----|----|
| -320 | Trans. | 181 | 189 | 16.0 | 242 | 1.28 | 184 | 2.5 | 94 |
| | Trans. | 180 | 189 | 16.0 | 243 | | 180 | 1.0 | |
| | Trans. | 182 | 191 | 17.0 | --- | | 172 | 0.5 | |
| | Trans. | 183 | 190 | 17.5 | --- | | 172 | 1.0 | |
| | Trans. | 184 | 192 | 16.5 | --- | | 186 | 3.0 | |
| | AVG. | 182 | 190 | 16.6 | 243 | | 179 | 1.6 | |
| -423 | Long. | 221 | 238 | 15.0 | 287 | | 226 | 2.5 | 93 |
| | Long. | 219 | 235 | 15.0 | 273 | | 215 | 1.0 | |
| | Long. | 228 | 243 | 10.0 | 266 | | 227 | 1.5 | |
| | Long. | 228 | 237 | ----- | 246 | | 222 | 1.5 | |
| | Long. | 230 | 242 | 12.0 | 230 | 1.09 | 218 | 1.0 | |
| | AVG. | 225 | 239 | 13.0 | 260 | | 222 | 1.5 | |
| -423 | Trans. | 224 | 232 | ---- | 270 | | 193 | 1.0 | |
| | Trans. | 225 | 232 | ---- | 253 | | 205 | 1.0 | |
| | Trans. | 229 | 238 | 10.5 | 230 | | 199 | 1.0 | |
| | Trans. | 227 | 237 | 11.0 | 246 | | 230 | 1.0 | |
| | Trans. | 227 | 236 | 12.5 | 236 | 1.05 | 243 | 1.0 | |
| | AVG. | 226 | 235 | 11.3 | 247 | | 214 | 1.0 | 91 |

* Chemistry: C-0.035; N₂-0.011; O₂-0.12; H₂-0.0099; Fe-0.11; Al-5.45; Sn-2.50; Ti-Rem.

Table 27 (Cont'd.)

| TEST TEMP (°F) | RESISTANCE SPOT WELD | | | |
|----------------|----------------------|------------|---------------------|--|
| | TENSION (LB) | SHEAR (LB) | TENSILE/SHEAR RATIO | |
| 78 | 100 | 530 | | |
| | 123 | 530 | | |
| | 119 | 555 | | |
| | 130 | 530 | | |
| | 131 | 500 | | |
| | 124 | 550 | | |
| | 126 | -- | | |
| | 128 | 455 | | |
| | 148 | 495 | | |
| | 146 | 465 | | |
| | 128 | 512 | 0.25 | |
| | -320 | 102 | 524 | |
| | | 86 | 488 | |
| 95 | | 542 | | |
| 91 | | 483 | | |
| 90 | | 564 | | |
| 80 | | 433 | | |
| 91 | | 476 | | |
| 80 | | 476 | | |
| 95 | | 534 | | |
| 88 | | 522 | | |
| 90 | | 504 | 0.18 | |
| -423 | | 75 | 485 | |
| | | 80 | 540 | |
| | 90 | 564 | | |
| | 75 | 630 | | |
| | 100 | 515 | | |
| | 85 | 520 | | |
| | 85 | 540 | | |
| | 75 | 485 | | |
| | 100 | 540 | | |
| | 75 | 535 | | |
| | 84 | 535 | 0.16 | |

Table 28. Fatigue Properties of Complex Welded Joints of Ti-5Al-2.5Sn Alloy
(0.014 In. Sheet, Republic Steel Co., Heat No. 3930131, Spec GD/A-0-71010)

| JOINT CONFIG. | DIR | TEST | | | NO. CYCLES TO FIRST LEAK | NO. CYCLES TO FAILURE | STATIC STRENGTH (KSI) | REMARKS |
|---------------|--------|-----------|-------------|--------------------|--------------------------|-----------------------|-----------------------|---------|
| | | TEMP (°F) | RANGE (KSI) | STRESS RANGE (KSI) | | | | |
| 1 | Long. | -423 | ----- | --- | --- | 193 | | |
| 1 | Long. | -423 | 0-140 | 50 | 405 | | | |
| 1 | Long. | -423 | 0-140 | 100 | 709 | | | |
| Average | | | | 75 | 557 | | | |
| 1 | Trans. | 78 | 0-88 | 400 | 751 | | | |
| 1 | Trans. | 78 | 0-88 | 550 | 1191 | | | |
| Average | | | | 475 | 971 | | | |
| 1 | Trans. | -320 | 0-140 | 150 | 320 | | | |
| 1 | Trans. | -320 | 0-140 | 150 | 420 | | | |
| Average | | | | 150 | 370 | | | |
| 1 | Trans. | -423 | ----- | --- | --- | 199 | | |
| 1 | Trans. | -423 | 0-140 | 50 | 358 | | | |
| 1 | Trans. | -423 | 0-140 | 50 | 273 | | | |
| Average | | | | 50 | 316 | | | |
| 3 | Long. | 78 | 0-102 | --- | 106 | | No failure. | |
| 3 | Long. | 78 | 0-102 | --- | 176 | | No failure. | |
| Average | | | | --- | 141 | | | |
| 3 | Long. | -320 | 0-140 | --- | 2100+ | | No failure. | |
| 3 | Long. | -320 | 0-140 | --- | 2100+ | | No failure. | |
| Average | | | | --- | 2100+ | | | |
| 3 | Long. | -423 | 0-140 | --- | 2000+ | | No failure. | |
| 3 | Long. | -423 | 0-140 | --- | 2000+ | | No failure. | |
| Average | | | | --- | 2000+ | | | |
| 3 | Long. | -423 | 0-192 | --- | 159 | | | |
| 3 | Long. | -423 | 0-192 | --- | 975 | | | |
| Average | | | | --- | 567 | | | |

Table 29A. Results of Statistical Analysis, F_{ty} (ksi)

| MATERIAL, CONDITION | GRAIN DIR | 78°F | | | -100°F | | |
|------------------------|-----------|------|------|------|--------|------|------|
| | | MEAN | s | B | MEAN | s | B |
| 301 SS, 60% CR | Long. | 200 | 3.08 | 182 | 237 | 2.97 | 219 |
| | Trans. | 176 | 1.79 | 166 | 197 | 3.77 | 175 |
| 304 SS, 50% CR | Long. | 158 | 3.96 | 135 | 179 | 3.35 | 160 |
| | Trans. | 151 | 1.95 | 140 | 174 | 5.63 | 141 |
| 310 SS, 75% CR | Long. | 156 | 3.51 | 136 | 185 | 2.88 | 169 |
| | Trans. | 157 | 4.72 | 130 | 185 | 6.58 | 147 |
| AM-355 SS, CRT | Long. | 278 | 4.16 | 254 | 287 | 4.97 | 259 |
| | Trans. | 251 | 2.19 | 238 | 252 | 2.41 | 238 |
| 2014-T6 | Long. | 65.2 | 0.68 | 61.3 | 68.2 | 0.32 | 66.3 |
| | Trans. | 63.1 | 0.28 | 61.5 | 65.9 | 0.25 | 64.5 |
| 5052-H38 | Long. | 36.1 | 0.43 | 33.7 | 37.2 | 0.52 | 34.2 |
| | Trans. | 36.0 | 0.30 | 34.3 | 37.2 | 0.92 | 31.9 |
| 5456-H343 | Long. | 49.2 | 0.62 | 45.6 | 50.9 | 1.07 | 44.7 |
| | Trans. | 43.1 | 0.13 | 42.4 | 43.8 | 0.30 | 42.0 |
| Ti-5Al-2.5Sn, Annealed | Long. | 116 | 0.84 | 111 | 135 | 4.72 | 107* |
| | Trans. | 117 | 0.55 | 114 | 137 | 1.34 | 130 |

* Value of s large so that $\bar{X} - k_A s < 0.80 \bar{X}$ and $\bar{X} - k_B s < 0.88 \bar{X}$

Table 29 A. (Cont)

| MATERIAL, CONDITION | GRAIN DIR | -320°F | | | | -423°F | | | |
|------------------------|-----------|--------|------|------|------|--------|------|-------|-------|
| | | MEAN | s | A | B | MEAN | s | A | B |
| 301 SS, 60% CR | Long. | 259 | 16.0 | 167* | 204* | 308 | 4.04 | 285 | 294 |
| | Trans. | 235 | 2.0 | 223 | 228 | 303 | 11.8 | 234* | 262* |
| 304 SS, 50% CR | Long. | 195 | 8.32 | 147 | 167 | 234 | 8.53 | 184* | 204* |
| | Trans. | 201 | 3.35 | 182 | 190 | 222 | 10.6 | 161* | 185* |
| 310 SS, 75% CR | Long. | 228 | 3.13 | 210 | 217 | 261 | 2.70 | 245 | 251 |
| | Trans. | 220 | 4.24 | 196 | 205 | 266 | 8.09 | 219 | 238 |
| AM-355 SS, CRT | Long. | 328 | 8.46 | 279 | 299 | * | * | | |
| | Trans. | 286 | 8.38 | 238 | 258 | * | * | | |
| 2014-T6 | Long. | 74.1 | 0.76 | 69.7 | 71.5 | 83.4 | 0.68 | 79.5 | 81.1 |
| | Trans. | 69.3 | 1.58 | 60.2 | 63.9 | 81.7 | 1.22 | 74.7 | 77.5 |
| 5052-H38 | Long. | 43.1 | 0.18 | 42.1 | 42.5 | 48.8 | 2.33 | 35.3* | 40.8* |
| | Trans. | 42.6 | 0.44 | 40.0 | 41.0 | 47.7 | 0.15 | 46.8 | 47.1 |
| 5456-H343 | Long. | 57.5 | 0.61 | 54.0 | 55.4 | 63.8 | 0.22 | 62.6 | 63.1 |
| | Trans. | 51.7 | 0.81 | 47.0 | 48.9 | 56.5 | 1.50 | 47.9 | 51.4 |
| Ti-5Al-2.5Sn, Annealed | Long. | 186 | 1.00 | 180 | 183 | 234 | 0.89 | 229 | 231 |
| | Trans. | 188 | 5.18 | 159 | 171 | 235 | 4.77 | 208 | 219 |

* Value of s large so that $\bar{X} - k_A s < 0.80 \bar{X}$ and $\bar{X} - k_B s < 0.88 \bar{X}$

** Insufficient test data to permit analysis

Table 29B. Results of Statistical Analysis, F_{tu} (ksi)

| MATERIAL, CONDITION | GRAIN DIR | 78°F | | | | | | -100°F | | | | | |
|------------------------|-----------|------|------|------|------|------|------|--------|------|--|--|--|--|
| | | MEAN | s | A | B | MEAN | s | A | B | | | | |
| | | | | | | | | | | | | | |
| 301 SS, 60% CR | Long. | 224 | 1.14 | 217 | 220 | 253 | 0.84 | 248 | 250 | | | | |
| | Trans. | 239 | 1.87 | 228 | 233 | 267 | 1.30 | 259 | 262 | | | | |
| 304 SS, 50% CR | Long. | 180 | 1.00 | 174 | 177 | 200 | 1.00 | 194 | 197 | | | | |
| | Trans. | 194 | 0 | --- | --- | 218 | 1.10 | 212 | 214 | | | | |
| 310 SS, 75% CR | Long. | 180 | 0.71 | 176 | 178 | 203 | 1.64 | 194 | 198 | | | | |
| | Trans. | 200 | 2.00 | 188 | 193 | 224 | 0.84 | 219 | 221 | | | | |
| AM-355 SS, CRT | Long. | 297 | 2.41 | 283 | 288 | 308 | 2.79 | 292 | 299 | | | | |
| | Trans. | 286 | 1.79 | 275 | 280 | 314 | 2.30 | 300 | 306 | | | | |
| 2014-T6 | Long. | 71.6 | 0.23 | 70.3 | 70.8 | 74.6 | 0.40 | 72.3 | 73.2 | | | | |
| | Trans. | 70.9 | 0.16 | 70.0 | 70.4 | 74.0 | 0.13 | 73.2 | 73.5 | | | | |
| 5052-H38 | Long. | 42.0 | 0 | --- | --- | 43.7 | 0.10 | 43.1 | 43.4 | | | | |
| | Trans. | 42.8 | 0.13 | 42.0 | 42.3 | 44.2 | 0.93 | 38.8 | 41.0 | | | | |
| 5456-H343 | Long. | 47.6 | 0.80 | 53.0 | 54.9 | 58.4 | 0.43 | 56.0 | 57.0 | | | | |
| | Trans. | 58.4 | 0.22 | 57.2 | 57.7 | 58.1 | 0.70 | 54.1 | 55.7 | | | | |
| Ti-5Al-2.5Sn, Annealed | Long. | 124 | 0.71 | 120 | 122 | 145 | 0.55 | 141 | 143 | | | | |
| | Trans. | 123 | 0.55 | 121 | 122 | 144 | 1.30 | 136 | 139 | | | | |

Table 29B. (Cont)

| MATERIAL, CONDITION | GRAIN DIR | -320°F | | | -423°F | | | |
|------------------------|-----------|--------|------|------|--------|------|-------|-------|
| | | MEAN | s | A B | MEAN | s | A B | |
| 301 SS, 60% CR | Long. | 323 | 1.11 | 318 | 320 | 5.81 | 302* | 315* |
| | Trans. | 326 | 0.89 | 321 | 323 | 5.68 | 313 | 326 |
| 304 SS, 50% CR | Long. | 242 | 9.34 | 188* | 210* | 3.83 | 253 | 262 |
| | Trans. | 255 | 3.27 | 236 | 244 | 6.35 | 262 | 275 |
| 310 SS, 75% CR | Long. | 253 | 1.30 | 245 | 248 | 2.07 | 279 | 284 |
| | Trans. | 272 | 1.79 | 262 | 266 | 7.91 | 268 | 287 |
| AM-355 SS, CRT | Long. | 353 | 2.44 | 341 | 346 | 21.0 | 225* | 274* |
| | Trans. | 342 | 6.43 | 305 | 320 | 14.0 | 258* | 291* |
| 2014-T6 | Long. | 85.5 | 0.29 | 83.9 | 84.5 | 1.52 | 92.3 | 95.8 |
| | Trans. | 84.5 | 0.05 | 84.1 | 84.3 | 1.21 | 94.6 | 97.4 |
| 5052-H38 | Long. | 60.7 | 0.05 | 60.4 | 60.6 | 1.50 | 78.5 | 82.0 |
| | Trans. | 57.1 | 0.19 | 56.0 | 56.5 | 0.13 | 75.4 | 75.7 |
| 5456-H343 | Long. | 74.8 | 0.70 | 70.8 | 72.4 | 2.11 | 76.3 | 81.2 |
| | Trans. | 72.4 | 0.27 | 70.8 | 71.4 | 3.52 | 61.8* | 70.0* |
| Ti-5Al-2.5Sn, Annealed | Long. | 198 | 1.00 | 192 | 195 | 0.84 | 245 | 247 |
| | Trans. | 199 | 6.02 | 165 | 179 | 7.96 | 202 | 221 |

* Value of s large so that $\bar{X} - k_A s < 0.80 \bar{X}$ and $\bar{X} - k_B s < 0.88 \bar{X}$

Table 29C. Results of Statistical Analysis, Weld T.S. (ksi)

| MATERIAL, CONDITION | GRAIN DIR | 78°F | | | | | | -100°F | | | | | |
|------------------------|-----------|------|------|-------|-------|------|------|--------|-------|--|--|--|--|
| | | MEAN | s | A | B | MEAN | s | A | B | | | | |
| | | | | | | | | | | | | | |
| 301 SS, 60% CR | Long. | 175 | 3.27 | 156 | 164 | 216 | 2.95 | 199 | 206 | | | | |
| | Trans. | 174 | 3.27 | 155 | 163 | 212 | 1.48 | 204 | 207 | | | | |
| 304 SS, 50% CR | Long. | 78.4 | 3.23 | 59.8 | 67.3 | 144 | 3.85 | 121 | 130 | | | | |
| | Trans. | 77.3 | 4.04 | 54.0 | 63.4 | 141 | 4.22 | 117 | 127 | | | | |
| 310 SS, 75% CR | Long. | 86.7 | 1.04 | 80.6 | 83.1 | 109 | 2.39 | 95.4 | 101 | | | | |
| | Trans. | 85.5 | 1.96 | 74.1 | 78.7 | 110 | 1.22 | 103 | 106 | | | | |
| AM-355 SS, CRT | Long. | 222 | 4.56 | 195 | 206 | 289 | 1.64 | 280 | 284 | | | | |
| | Trans. | 219 | 3.63 | 198 | 207 | 282 | 1.92 | 271 | 276 | | | | |
| 2014-T6 | Long. | 55.4 | 2.98 | 38.1* | 45.1* | 56.4 | 2.84 | 40.0* | 46.6* | | | | |
| | Trans. | 58.6 | 0.85 | 53.7 | 55.7 | 58.2 | 0.37 | 56.0 | 56.9 | | | | |
| 5052-H38 | Long. | 32.0 | 0.73 | 27.8 | 29.5 | 34.2 | 0.11 | 33.6 | 33.8 | | | | |
| | Trans. | 33.3 | 0.17 | 32.3 | 32.7 | 34.5 | 0.20 | 33.3 | 33.8 | | | | |
| 5456-H343 | Long. | 53.0 | 0.45 | 50.4 | 51.5 | 52.6 | 0.37 | 50.5 | 51.3 | | | | |
| | Trans. | 51.4 | 0.28 | 49.8 | 50.4 | 50.4 | 0.92 | 45.1 | 47.2 | | | | |
| Ti-5Al-2.5Sn, Annealed | Long. | 123 | 0.45 | 121 | 122 | 146 | 0.89 | 140 | 143 | | | | |
| | Trans. | 120 | 1.79 | 110 | 114 | 142 | 1.30 | 134 | 137 | | | | |

* Value of s large so that $\bar{X} - k_A s < 0.80 \bar{X}$ and $\bar{X} - k_B s < 0.86 \bar{X}$

Table 29C. (Cont)

| MATERIAL, CONDITION | GRAIN DIR | -320°F | | | -423°F | | | | |
|------------------------|-----------|--------|------|-------|--------|--------|------|-------|-------|
| | | MEAN | s | A | B | MEAN | s | A | B |
| 301 SS, 60% CR | Long. | 298 | 2.70 | 283 | 289 | 202*** | 21.6 | 76.6* | 127* |
| | Trans. | 291 | 2.30 | 277 | 283 | 204*** | 29.3 | 35.1* | 103* |
| 304 SS, 50% CR | Long. | 216 | 1.10 | 209 | 212 | 250 | 3.39 | 230 | 238 |
| | Trans. | 212 | 8.07 | 166* | 184* | 269 | 6.34 | 232 | 247 |
| 310 SS, 75% CR | Long. | 162 | 4.56 | 136 | 147 | 208 | 3.74 | 186 | 195 |
| | Trans. | 167 | 1.34 | 160 | 163 | 193 | 4.64 | 166 | 177 |
| AM-355 SS, CRT | Long. | 271 | 25.7 | 123* | 183* | 142 | 5.24 | 112* | 124* |
| | Trans. | 299 | 19.2 | 188* | 233* | 140 | 8.53 | 91.1* | 111* |
| 2014-T6 | Long. | 63.2 | 2.15 | 50.8 | 55.8 | 70.8 | 6.07 | 35.7* | 49.9* |
| | Trans. | 65.7 | 1.36 | 57.8 | 61.0 | 73.8 | 3.45 | 53.9* | 61.9* |
| 5052-H38 | Long. | 47.3 | 3.60 | 26.5* | 34.9* | 70.1 | 1.21 | 63.1 | 66.0 |
| | Trans. | 51.1 | 0.48 | 48.4 | 49.5 | 68.9 | 3.19 | 50.4* | 57.9* |
| 5456-H343 | Long. | 68.3 | 0.23 | 67.0 | 67.5 | 66.3 | 1.55 | 57.4 | 61.0 |
| | Trans. | 65.3 | 1.21 | 58.3 | 61.1 | 66.6 | 2.98 | 49.4* | 56.3* |
| Ti-5Al-2.5Sn, Annealed | Long. | 200 | 0.84 | 195 | 197 | 245 | 2.74 | 229 | 236 |
| | Trans. | 196 | 9.92 | 139* | 162* | 242 | 1.95 | 231 | 236 |

* Value of s large so that $\bar{X} - k_A s < 0.80 \bar{X}$ and $\bar{X} - k_B s < 0.88 \bar{X}$

***Low values with large standard deviation probably indicates severe embrittlement, not necessarily typical of 301 SS

Table 29D. Results of Statistical Analysis, Spot Weld Tension and Shear, Ultimate (lb)

| MATERIAL, CONDITION | TEST | 78°F | | | | -100°F | | | |
|------------------------|---------|------|------|------|------|--------|------|------|------|
| | | MEAN | s | A | B | MEAN | s | A | B |
| 301 SS, 60% CR | Tensile | 662 | 31.0 | 559 | 602 | 593 | 28.9 | 498 | 538 |
| | Shear | 1052 | 38.3 | 925 | 978 | 1281 | 41.6 | 1143 | 1200 |
| 304 SS, 50% CR | Tensile | 256 | 11.1 | 220 | 235 | 242 | 17.5 | 184* | 208* |
| | Shear | 409 | 12.6 | 368 | 385 | 510 | 34.6 | 396* | 443* |
| 310 SS, 75% CR | Tensile | 509 | 13.9 | 463 | 482 | 562 | 37.0 | 440* | 491* |
| | Shear | 744 | 23.1 | 668 | 699 | 871 | 26.7 | 783 | 820 |
| AM-355 SS, CRT | Tensile | 851 | 38.4 | 691 | 758 | 298 | 44.9 | 150 | 211* |
| | Shear | 1529 | 95.4 | 1214 | 1345 | 1758 | 103 | 1420 | 1561 |
| Ti-5Al-2.5Sn, Annealed | Tensile | 360 | 32.9 | 252 | 297 | 256 | 28.6 | 162* | 201* |
| | Shear | 1381 | 41.0 | 1245 | 1302 | 1381 | 74.5 | 1135 | 1237 |

* Value of s large so that $\bar{X} - k_A s < 0.80 \bar{X}$ and $\bar{X} - k_B s < 0.88 \bar{X}$

Table 29D. (Cont)

| MATERIAL, CONDITION | TEST | -320°F | | | | -423°F | | | |
|------------------------|---------|--------|------|------|------|--------|------|-------|-------|
| | | MEAN | s | A | B | MEAN | s | A | B |
| 301 SS, 60% CR | Tensile | 160 | 24.7 | 78.8 | 113 | 143 | 27.7 | 51.5* | 89.5* |
| | Shear | 1041 | 97.1 | 721 | 854 | 825 | 52.6 | 652* | 724* |
| 304 SS, 50% CR | Tensile | 265 | 17.2 | 208* | 232* | 306 | 37.5 | 183* | 234* |
| | Shear | 634 | 24.9 | 552 | 586 | 666 | 34.3 | 553 | 600 |
| 310 SS, 75% CR | Tensile | 582 | 31.6 | 478 | 522 | 533 | 38.6 | 406* | 459* |
| | Shear | 1096 | 29.9 | 998 | 1039 | 1224 | 53.2 | 1049 | 1122 |
| AM-355 SS, CRT | Tensile | 186 | 9.42 | 155 | 168 | 162 | 22.2 | 88.3* | 119* |
| | Shear | 903 | 39.0 | 774 | 828 | 858 | 64.7 | 645* | 734* |
| Ti-5Al-2.5Sn, Annealed | Tensile | 268 | 20.1 | 202* | 229* | 251 | 26.3 | 164* | 200* |
| | Shear | 1670 | 52.3 | 1498 | 1570 | 1587 | 83.2 | 1313 | 1427 |

* Value of s large so that $\bar{X} - k_A s < 0.80 \bar{X}$ and $\bar{X} - k_B s < 0.88 \bar{X}$

Table 30. Materials Recommended for Future Study

| MATERIAL, TEMPER | GAUGE (IN.) | STRENGTH/DENSITY RATIO (IN. X 10 ⁶) | RECOMMENDED TEST CONDITIONS (FROM 78°F to -423°F) |
|----------------------------|-------------|--|--|
| 301 SS, 60% CR | 0.020-0.030 | 0.76 | Crack Propagation. |
| 304 SS, 50-60% CR | 0.020-0.030 | 0.61 | Crack Propagation. |
| 310 SS, 75% CR | 0.020-0.030 | 0.62 | Crack Propagation. |
| AM-355 SS, CRT | 0.020-0.030 | 0.89 | Crack Propagation. |
| Rene 41, Aged | 0.020-0.030 | 0.46 | Tensile, Fatigue, and Crack Propagation. |
| Hastelloy B, 40% CR | 0.020-0.030 | 0.63 | Tensile, Fatigue, and Crack Propagation. |
| 20 or 25% Ni Steel, 50% CR | 0.020-0.030 | 0.54 | Tensile, Fatigue, and Crack Propagation. |
| 2014 Al Alloy, T6 | 0.063 | 0.68 | Crack Propagation. |
| 2219 Al-Alloy, T87 | 0.063-0.125 | 0.59 | Tensile, Fatigue, and Crack Propagation. |
| 5052 Al-Alloy, H38 | 0.063 | 0.47 | Crack Propagation. |
| 5456 Al-Alloy, H343 | 0.063 | 0.45 | Crack Propagation. |
| Ti-5Al-2.5Sn, Annealed | 0.025-0.040 | 0.75 | Crack Propagation. |
| Ti-5Al-2.5Sn, 20-30% CR | 0.025-0.040 | 0.80-0.90 | Tensile, Fatigue, and Crack Propagation. |
| Ti-6Al-4V, Annealed | 0.025-0.040 | 0.83 | Tensile, Fatigue, and Crack Propagation. |
| Ti-8Al-2Cb-1Ta, Annealed | 0.025-0.040 | 0.86 | Tensile, Fatigue, and Crack Propagation. |

DISTRIBUTION LIST

| | No. of Copies |
|---|---------------|
| 1. Commander, Aeronautical Systems Division Attention: ASRCEE-1 (Mr. M. Knight) Load Bearing Materials Section Applications Laboratory Directorate of Materials and Processes Wright-Patterson AFB, Ohio | 5 |
| 2. Commander Aeronautical Systems Division ATTN: WWFEVS (Mr. C. W. Gerhardt) Wright-Patterson AFB, Ohio | 1 |
| 3. Commander Aeronautical Systems Division ATTN: WWRMPR-3 (Mr. C. M. Donaldson) Wright-Patterson AFB, Ohio | 1 |
| 4. Commander Aeronautical Systems Division ATTN: WWDRPH (Mr. W. E. Tournay) Wright-Patterson AFB, Ohio | 1 |
| 5. Commander Aeronautical Systems Division ATTN: WWRMFS-2 (Mr. C. Elrod) Wright-Patterson AFB, Ohio | 1 |
| 6. Aerojet-General Corporation ATTN: Mr. R. C. Stiff Department 8100 Box 1947 Sacramento 9, California | 1 |
| 7. Aerospace Industries Association ATTN: H. D. Moran Technical Service Secretary 7660 Beverly Blvd. Los Angeles 36, California | 6 |
| 8. Battelle Memorial Institute ATTN: Mr. D. N. Gideon 505 King Avenue Columbus 1, Ohio | 1 |

DISTRIBUTION LIST (Cont)

| | No. of Copies |
|---|---------------|
| 9. Battelle Memorial Institute Defense Metals Information Center 505 King Avenue Columbus 1, Ohio | 1 |
| 10. Boeing Airplane Company ATTN: Mr. O. T. Ritchie Aero Space Division P. O. Box 3707 Seattle, Washington | 1 |
| 11. Chance Vought Aircraft Inc. ATTN: Mr. Y. J. Elizondo Structures Design, Gp. 53400 Dallas, Texas | 1 |
| 12. Chrysler Corporation ATTN: Mr. R. E. Mahr Missile Division P. O. Box 2628 Detroit 31, Michigan | 1 |
| 13. Curtis-Wright Corporation ATTN: Mr. John E. Snow Development Engineering Dept. Quehanna, Pennsylvania | 1 |
| 14. Department of the Navy Bureau of Weapons Code: RRMA-211, ATTN: R. Schmidt Washington, D. C. | 1 |
| 15. Douglas Aircraft Company ATTN: G. E. Bockrath Santa Monica, California | 1 |
| 16. General Electric Company ATTN: Norris F. Dow Missile and Space Vehicle Dept. 3750 "D" Street Philadelphia 24, Pa. | 1 |

DISTRIBUTION LIST (Cont)

| | No. of Copies |
|---|---------------|
| 17. Joan Barriage FAA, T-4 Bldg., RM 2114 Washington 25, D. C. | 1 |
| 18. Lockheed Aircraft Corp. ATTN: Francis J. Clauss Ph. D. Missile and Space Division 3251 Hanover Street Palo Alto, California | 1 |
| 19. Marquardt Corporation ATTN: Mr. Donald Weisert Materials and Processes Lab. 16555 Saticoy Street Van Nuys, California | 1 |
| 20. Martin Company ATTN: G. H. Sprague, Chief, Struct. Eng. Orlando, Florida, MP144 | 1 |
| 21. McDonnell Aircraft Corporation ATTN: Mr. Howard J. Siegel Materials, Processes and Development Dept. Lambert-Saint Louis Municipal Airport St. Louis, Missouri | 1 |
| 22. National Aeronautics and Space Adm. Lewis Research Center ATTN: W. F. Brown, Jr., Chief Strength of Materials Branch 21000 Brookpark Road Cleveland 35, Ohio | 1 |
| 23. Naval Research Laboratories Mechanics Dept. ATTN: George Irwin Washington 25, D. C. | 1 |
| 24. North American Aviation ATTN: L. P. Spalding, Section Head, Materials Los Angeles International Airport Los Angeles 45, California | 1 |

DISTRIBUTION LIST (Cont)

| | No. of Copies |
|---|---------------|
| 25. Northrop Corporation Norair Division ATTN: Mr. A. P. Binsacca Materials and Processes Engineering Hawthorne, California | 1 |
| 26. Republic Aviation Corporation ATTN: Mr. Frederick W. Eversley, Jr. Chief, Materials Application Farmingdale, L. I., New York | 1 |
| 27. Space Technology Laboratories, Inc. ATTN: William F. McGrath B-1054A P. O. Box 95001 Los Angeles 45, California | 1 |
| 28. Thompson-Ramo-Wooldridge, Inc. ATTN: Mr. W. J. Piper 23555 Euclid Avenue Cleveland 17, Ohio | 1 |
| 29. Watertown Arsenal ATTN: Mr. C. Hartbower and Mr. G. M. Orner Watertown 72, Massachusetts | 1 |
| 30. Douglas Aircraft Company, Inc. ATTN: J. L. Waismann, A-270 3000 Ocean Park Blvd. Santa Monica, California | 1 |
| 31. Titanium Metals Corporation of America 6565 Corvette Street Los Angeles 22, California Attention: Mr. D. A. Wruck | 1 |
| 32. The John Hopkins University Applied Physics Laboratory 8621 Georgia Avenue Silver Spring, Maryland | 1 |
| 33. Airteck Dynamics Attention: Mr. Bruce L. Baird 18201 South Santa Fe Avenue Compton, California | 1 |

DISTRIBUTION LIST (Cont)

| | No. of Copies |
|--|---------------|
| 34. Materials Branch Attention: Dr. R. Lucas George C. Marshall Space Flight Center National Aeronautics & Space Administration Huntsville, Alabama | 1 |
| 35. Andre Portland, Inc. Attention: Dr. Grady McKee 100 Century Road Paramus, New Jersey | 1 |
| 36. Kaiser Aluminum and Chemical Corporation ATTN: Mr. T. R. Pritchett Department of Metallurgical Research Spokane 69, Washington | 1 |
| 37. Commander Aeronautical Systems Division ATTN: ASNRFM (H. J. Middendorp) Wright-Patterson AFB, Ohio | 1 |
| 38. Allied Research Associates ATTN: Dr. F. W. French 43 Leon Street Boston, Massachusetts | 1 |