

Contracts

FOREWORD

This program was conducted for the Biomedical Laboratory of the 6570th Aerospace Medical Research Laboratories, Aerospace Medical Division, Wright-Patterson Air Force Base, Ohio. The research was conducted by the General Electric Company's Missile and Space Division at the Valley Forge Space Technology Center, Box 8555, Philadelphia 1, Pennsylvania, under contract No. AF 33(657)-7667. Mr. Fred Rudek, Life Support Engineer, and Mr. Norman Belasco, Supervising Engineer, were the principal project engineers for the General Electric Company. Mr. William H. Toliver, Sr., Research Chemist, of the Respiratory Equipment Branch, Biomedical Division, was the contract monitor for the 6570th Aerospace Medical Research Laboratories. The work was performed in support of Project 6373, "Equipment for Life Support in Aerospace," Task No. 637304, "Waste Recovery and Utilization." The study and research sponsored by this contract was started in March 1962 and was completed in February 1963.

The authors acknowledge the assistance of the following General Electric Company consultants: Dr. E. A. Oster, Manager, Fuel Cell Laboratory, and Mr. B. Mooradian, Gemini Program, of Direct Energy Conversion Operation, Lynn, Mass.; Dr. William Carson, General Engineering Laboratory, and Dr. L. Neidrach, Research Laboratory, Schenectady, N. Y., and Mr. M. D. Read, Mr. J. F. Hall, and Dr. T. K. Slaweki, of the Missile and Space Division, Philadelphia, Pa.

Special acknowledgement is included for Mr. R. Hayes, Life Support Laboratory Technician, who assisted in conducting the laboratory experimental tests.

Contrails

ABSTRACT

A program of study and applied research was conducted to determine the feasibility of combining an ion exchange membrane electrolysis cell and an ion exchange membrane fuel cell so that oxygen and hydrogen which are electrolyzed from human urine recombine in the fuel cell to yield potable water and power. The latter, in turn, will satisfy some of the power requirements of the electrolysis cell. The experimental laboratory systems were synthesized from latest ion-exchange membrane technology, and produced water that is both chemically and bacteriologically well within limits of the "1961 U.S. Public Health Standards for Drinking Water." The system has high yield (98% of available water content), long operating life (37 days plus), and produces usable low-voltage electrical power. The electrolysis cell output also provides for a high-purity (to 99.5%) emergency oxygen capability. The design is basically a zero-G type, inherently providing separation of vapor and liquid. Trade-off evaluations indicate that the ELF System is competitive with other water-recovery systems presently being developed for space applications. Characteristic features of a three-man system are: weight 67 pounds; volume, 1.6 cubic feet; and power consumption, 650 watts for continuous operation. The flexibility, reliability, and overall simplicity of the ELF system make this water recovery technique a strong contender for future space applications.

PUBLICATION REVIEW

This technical documentary report has been reviewed and is approved.

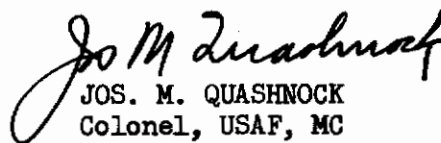

JOS. M. QUASHNOCK
Colonel, USAF, MC
Chief, Biomedical Laboratory

TABLE OF CONTENTS

	<u>Page</u>
SECTION I INTRODUCTION	1
BACKGROUND	1
OBJECTIVE	1
APPROACH	2
SECTION II THE ELF TECHNIQUE	3
WHAT ARE FUEL CELLS	3
Fuel Cell Operation	3
Ion Exchange Membrane Fuel Cells	4
Reversible Nature of Ion Membrane Cells.	4
ION EXCHANGE MEMBRANE ELECTROLYSIS CELL	8
THE "ELF" TECHNIQUE	8
Required Research.	8
APPROACH.	14
SECTION III DESIGN ANALYSIS.	16
FUEL CELL THEORY.	16
Leached Organic Membranes.	16
Membrane Electrolytes.	17
Functional Mode.	17
ELECTROLYSIS THEORY	18
Decomposition Voltage.	19
Overvoltage.	21
Resistance Losses.	22
ELF SYSTEM THEORY	25
Energy Balance	27
Material Balance	27
Heat Balance	29
Energy and Material Balance.	29
SECTION IV RESEARCH AND EXPERIMENTATION.	31
PRELIMINARY EXPERIMENTS	31
COMPONENT/SUBSYSTEM EVALUATION.	33
TEST PLAN	33

Contrails

TABLE OF CONTENTS (continued)

	<u>Page</u>
SECTION IV (Continued)	
SINGLE ANIONIC CELLS	34
SINGLE CATIONIC CELLS	37
Electrolysis Cells	39
Pocket Cell Tests	44
Product Water Quality	49
MULTI-CELL TESTING	51
SECTION V EVALUATIONS	55
ADVANCED ELF SYSTEM DESCRIPTION	55
Electrolysis Module	55
Fuel Cell Module	57
Physical Characteristics	57
TRADEOFF STUDIES	59
Other Systems	59
Tradeoff Analyses	66
Results	67
SECTION VI CONCLUSIONS AND RECOMMENDATIONS	70
CONCLUSIONS	70
RECOMMENDATIONS	74
SECTION VII REFERENCES	76
SECTION VII APPENDICES	79
APPENDIX A	
Results of Water Sample Analysis from Initial Feasibility Testing	79
APPENDIX B	
Results of Water Analysis from Laboratory Experimental System	81

Contrails

LIST OF ILLUSTRATIONS

<u>Figure</u>		<u>Page</u>
1	Basic Fuel Cell Operation.	4
2	Chart of 3-Way Action.	6
3	Ion Membrane Fuel Cell	7
4	Ion Membrane Electrolysis Cell	9
5	ELF System Block Diagram.	10
6	Original Laboratory System	11
7	Decomposition Voltage.	20
8	Effect of Electrolyte Concentration on Resistivity.	24
9	Effect of Temperature on Electrolyte Resistivity.	26
10	Theoretical Energy and Material Balances for ELF Water Recovery System.	30
11	Test Set-up for Standard Platinum Electrolysis Cell.	32
12	Anionic Membrane Electrolysis Cell Assembly.	35
13	KOH Operating Curves	36
14	Laboratory Test Set-up for Water Recovery.	38
15	Cationic Membrane Electrolysis Cell.	40
16	Two Membrane Electrolysis Cell	42
17	Double Membrane Electrolysis Cell.	43
18	Cross-sectional View of Two Cell Stack.	44
19	Laboratory Testing of Individual Cells	45
20	Multi-cell ELF Test System	52
21	ELF Test System Schematic.	53

LIST OF ILLUSTRATIONS
(Continued)

<u>Figure</u>		<u>Page</u>
22	Comparison of "Before" and "After" use to Show Salt Deposits	54
23	Advanced ELF System Schematic.	56
24	Liquid Internally Cooled Cell Installation . .	58
25	Schematic of Vapor Compression System	61
26	Schematic of Electrodialysis Unit.	64
27	Weight Comparisons for Water Recovery Systems.	68
28	Comparison of Cell Voltage	73

LIST OF TABLES

<u>Table</u>		<u>Page</u>
1	Composition of a Typical Normal Urine.	28
2	Test Summary	47
3	Analysis of Electrolysis Cell Outputs.	48
4	Chemical Analysis for Recovered Water.	50
5	Advanced ELF System Statistics	57
6	Summary of Water Processing Systems.	66
7	Electrolytic Oxygen Generator.	74

Contracts

SECTION I

INTRODUCTION

BACKGROUND

Extended duration space missions require closed ecologies for sustaining the operating crews. The foundation of these closed ecologies is reclamation of waste products for reuse, thus minimizing supply storage requirements. One of the basic portions of this closed ecology concept requires reclamation of potable water from human metabolic waste water.

A number of diversified approaches for the solution of this problem have been proposed and/or tried with varying degrees of success. In general, these proposed waste water regeneration systems have major deterring features. The deterring features in many cases are of such a magnitude as to compromise the complete system for specific space vehicle applications. In other instances, the proposed systems require extensive development programs to determine their design details.

The ELF system (electrolysis cell-fuel cell system) conceived in 1959 as a result of the General Electric Company's independent research represents a new and novel approach to the problem of waste water reclamation.

The ELF technique combines ion exchange membrane electrolysis cells with solid electrolyte ion exchange membrane fuel cells. Functionally, the electrolysis cells utilize a unique electrolyzer to extract the water content of urine as individual hydrogen and oxygen gases. The gases in turn are supplied to fuel cells, which recombine the two gases thus producing water and usable electrical power. The water can be stored for use, and the electrical power can reduce the power requirements of the electrolysis cell.

This approach to water recovery is unique in that the system is simple and free from moving parts. Designs are inherently zero G oriented because of the functional requirements of liquid/vapor phase separation. In addition, it offers the advantageous option of selectively channeling oxygen gas for emergency breathing systems, and hydrogen gas for CO₂ reduction processes.

OBJECTIVE

A program of applied research has been conducted to determine the feasibility of the ELF technique for recovering potable water from human urine, and to provide criteria to evaluate its applicability for manned space vehicle life support systems.

APPROACH

Latest advances in ion exchange membrane technology, and design innovations specifically generated for the intended application were integrated with the basic ELF technique to synthesize laboratory systems. When operated, these systems provided data as to the chemical and bacteriological purity, (and hence potability), design performance (efficiencies, yield, life, etc.), and operating characteristics, (power requirements, flows, temperatures, etc.).

The results of the laboratory experimental efforts and the studies of the latest advances in ion exchange membrane technology (achieved and contemplated) were combined, analyzed, and synthesized to provide information upon which an operational system design concept was based.

A trade-off analysis was then conducted to compare the ELF operational system design concept with other promising operational system concepts (such as vacuum pyrolysis, electro-dialysis, vapor compression, etc.). The analysis considers important vehicle system integration factors such as power, volume, weight, maintenance, zero G design, additional head end or tail end treatment, yields, efficiencies, etc.

The results of the program provide significant information as to the application potential, the limiting characteristics, and development needs of the ELF operational design concept.

SECTION II

THE ELF TECHNIQUE

The ELF technique is primarily intended for the recovery of potable water from human urine. The system combines ion exchange membrane electrolysis cells (which electrolyze the water content of urine into oxygen and hydrogen gases) with solid electrolyte ion exchange membrane fuel cells, which recombine these gases to produce water and usable power.

A review of the theory and fundamentals of the ELF technique and its functional components will be advantageous to better understand the program and interpret the significance of its results.

WHAT ARE FUEL CELLS

A Fuel Cell is a continuous-feed electrochemical device in which the chemical energy of the reaction of a conventional fuel and air (oxygen) is converted directly into useful low voltage direct current electricity (Ref. 1). A fuel cell differs from a battery in two major respects:

1. It can operate continuously as long as fuel and air are available.
2. It uses hydrocarbons (or some derivative such as hydrogen for fuel).

The hydrogen-oxygen fuel cell reverses the well-known process of electrolysis. Instead of separating water into its components by passing an electrical current through it, water is created in a controlled reaction which liberates energy in the form of electricity. The concurrent production of water and electricity is not subject to the Carnot limitation.

Fuel Cell Operation

In a typical fuel cell, with an acid electrolyte, figure 1, hydrogen reacts at the anode to give up an electron (e^-) to the load while simultaneously releasing hydrogen ions (H^+) in the solution. At the cathode, these hydrogen ions combine with oxygen and electrons from the load circuit to produce water. In an alkaline system, hydroxyl ions are the charge carriers in the electrolyte, and the water is formed at the anode. Both material and electrical charge balance are maintained by migration of both electrons and ions. Interrupting electron flow in the external circuit or ion flow in the internal circuit interrupts the power.

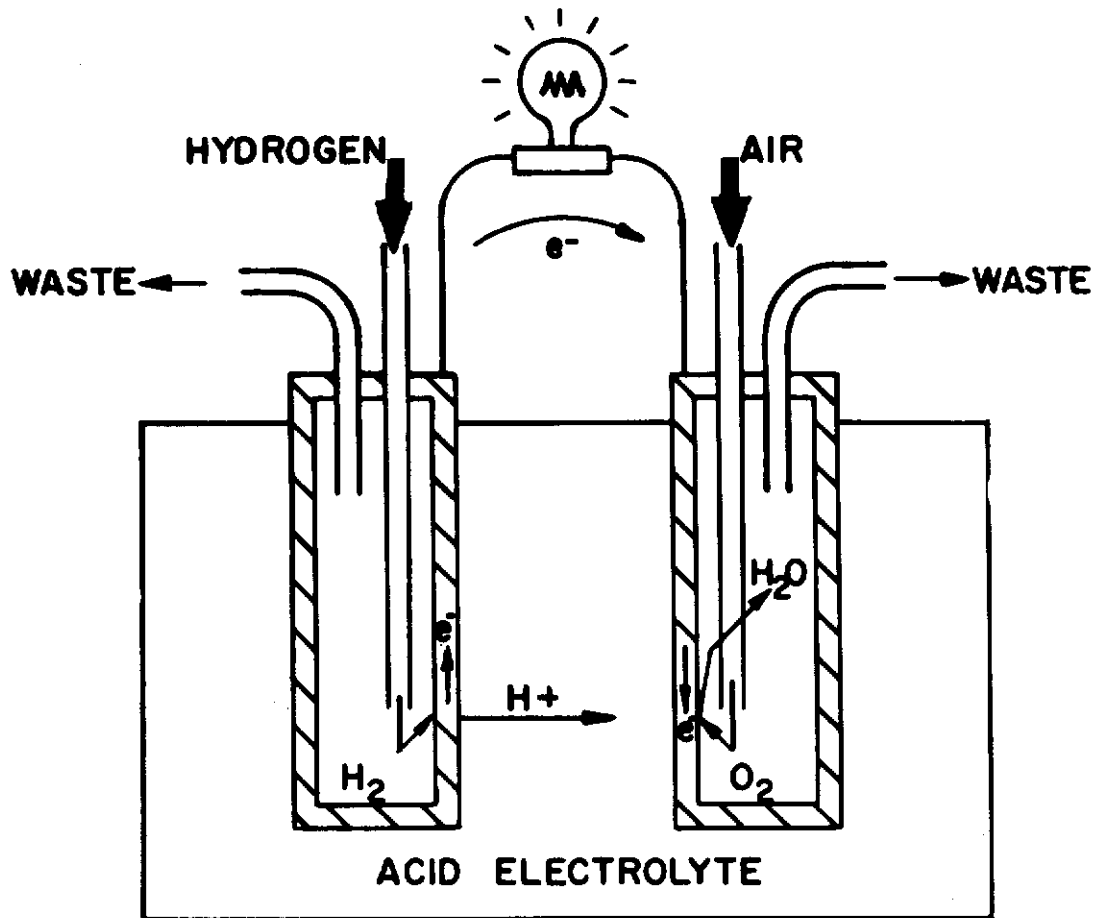

Figure 1. Basic Fuel Cell Operation

TYPICAL HYDROGEN-OXYGEN FUEL CELL consists of two porous electrodes separated by an electrolyte. Hydrogen is supplied to one electrode and diffuses through it. On the anode surface, hydrogen reacts with the electrolyte, giving up electrons to the electrode and ions to the electrolyte. The ions migrate through the electrolyte to the surface of the other electrode. There they combine with electrons that have traveled the external circuit, and with the oxygen diffused through the electrode, to form water.

Contrails

The basic problem that must be solved in design of fuel cells is how to obtain sufficient fuel-electrode-electrolyte reaction sites in a given volume. The pie chart, figure 2 illustrates the three-way action which occurs at the anode of a typical hydrogen-oxygen cell using acid electrolyte. Hydrogen (a gas) gives up an electron to the electrode (usually a solid), and ions to the electrolyte (in this case a membrane). In the two dimensional chart, the only place for simultaneous contact of all three--solid, electrolyte, and gas-- is at a point. In three dimensions, this becomes a line. Obtaining enough reaction sites in a given volume is a problem.

Consider what happens when there is a pressure imbalance between the gas and liquid. If the gas covers the electrode, excluding the electrolyte, ion flow is interrupted. If the electrolyte drowns the electrode, excluding the gas, electron flow is interrupted. In either case cell action ceases. At the other electrode, the added need exists to remove water formed by the gas reaction.

In summary, systems must be so designed that, despite changing loads, the simultaneous triple contact (solid-gas-electrolyte) remains relatively stable.

Ion-Exchange Membrane Fuel Cells

General Electric's ion-exchange membrane fuel cell solves the triple contact stability problem by eliminating the free liquid phase entirely. All reaction sites are "frozen" by use of a solid electrolyte, a plastic membrane which permits hydrogen ions to migrate from one electrode to the other.

The simple schematic of a hydrogen-oxygen ion-exchange membrane fuel cell, figure 3, shows how it works. Hydrogen and oxygen enter chambers on opposite sides of the ion-permeable membrane, and penetrate the porous electrodes to contact the surfaces of the membrane. On the hydrogen side, the electrons are given up, collected in the electrode and conducted to the load. The hydrogen ions travel through the solid electrolyte to the other surface of the membrane where they combine with the returning electrons in the presence of oxygen. Result: the formation of water and the release of useful electrical energy.

Reversible Nature of Ion-Membrane Cells

The ion-membrane fuel cell has the interesting ability to run "backwards," or be "charged," in much the same manner as a secondary battery. In this mode of operation, instead of feeding in H_2 and O_2 gases, all orifices are sealed off and the membrane is partially immersed in water. The electrons flowing into the hydrogen electrode attract hydrogen ions through the membrane. There the ions combine with electrons to form hydrogen gas. Oxygen released from the water remains on

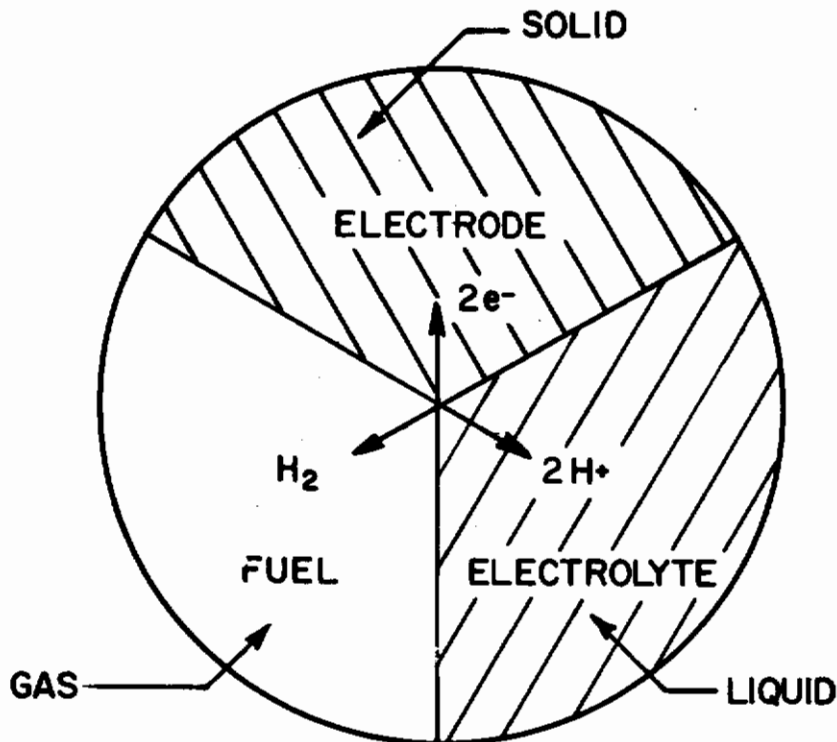

Figure 2. Chart of Three-Way Action at the Anode of a hydrogen-oxygen cell.

PROBLEM: Finding sufficient reaction sites in a given volume for simultaneous contact of liquid, gas, solid. Schematic represents hydrogen electrode of acid type cell. Similar difficulties exist in alkaline cells, complicated by the formation of water at the electrode.

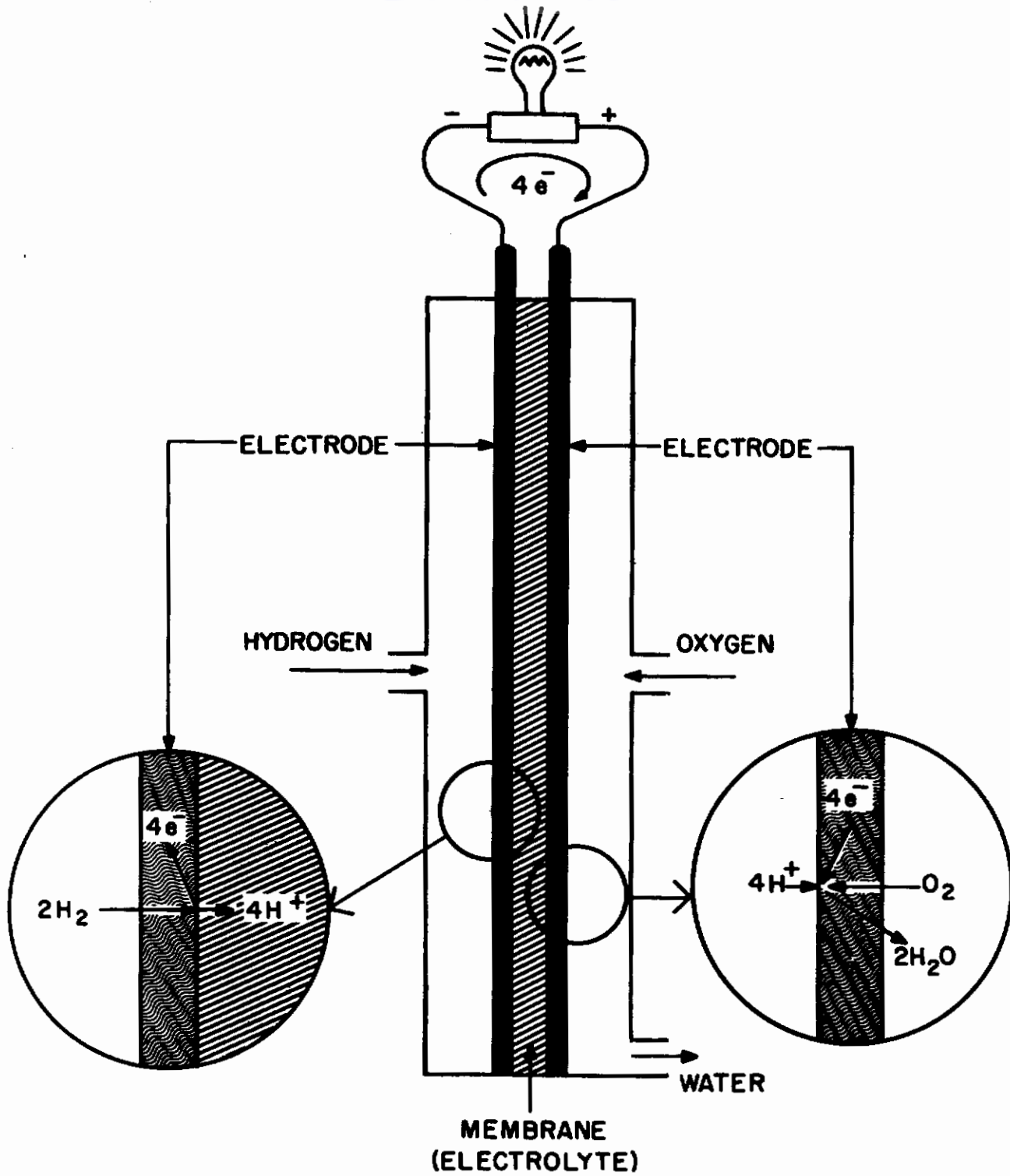

FIGURE 3 ION-MEMBRANE FUEL CELL

Contrails

the other side of the membrane. If the charging current is interrupted, the cell instantly commences operation in its normal mode. This reversibility is the primary feature which permits use of the ion-exchange membrane (IEM) fuel cell fundamentals to perform electrolysis functions.

ION EXCHANGE MEMBRANE ELECTROLYSIS CELL

In the foregoing paragraphs, the ability of these IEM Cells to work in reverse was explained. Through the application of this reversibility an electrolysis function can be performed, as shown in figure 4.

While operating as an electrolyzer, water and electrical power are supplied to the cell. Water is dissociated by the removal of electrons through the external circuit leaving hydrogen ions and oxygen gas. Ion transfer occurs through the membrane as in the fuel cell, until hydrogen ions are combined with the externally supplied electrons to form hydrogen gas.

THE ELF TECHNIQUE

The ELF Technique combines both the IEM cell functions previously described, i.e., electrolysis cell and fuel cell. The IEM Electrolysis Cell, first unit in the system sequence, figure 5, disassociates the water content of the urine to produce hydrogen and oxygen gases. These gases are transported to the second member of the ELF couple, the IEM Fuel Cell, where the gases are recombined to produce water and electrical power.

The basic feasibility of the system operation was established in an independent research effort (Ref. 2) but considerable research was required before specific feasibility for application to manned space vehicle systems could be determined. Figure 6 shows the first experimental unit.

Required Research

Once the basic feasibility of the ELF technique for producing potable water from human urine had been determined, its potential for space vehicle applications was recognized. Most prominent of the system features which highlighted potential space vehicle application were derived from the initial experiments. These include:

1. The ELF system can function as theorized, producing reasonably good quality water directly from urine.

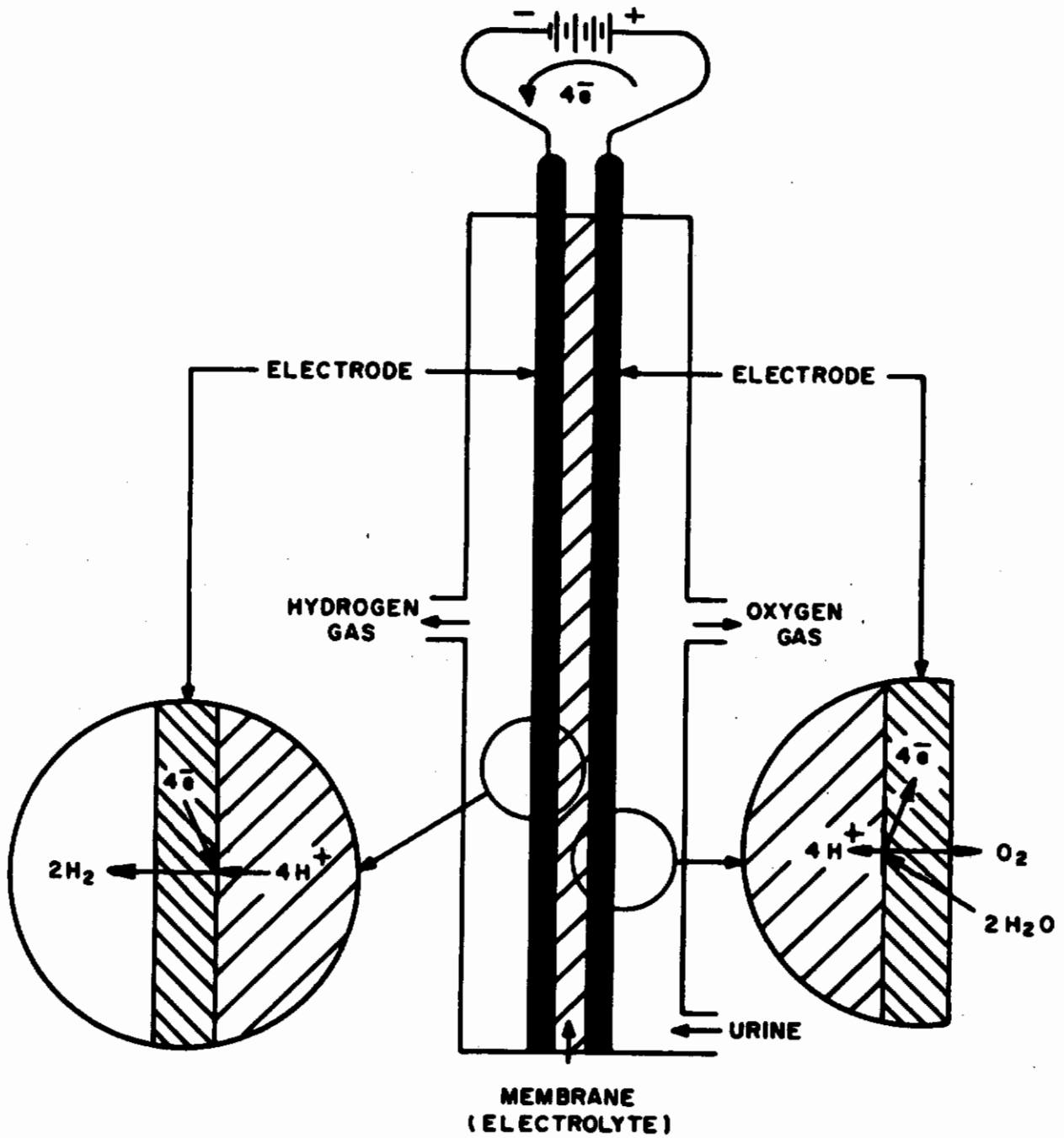
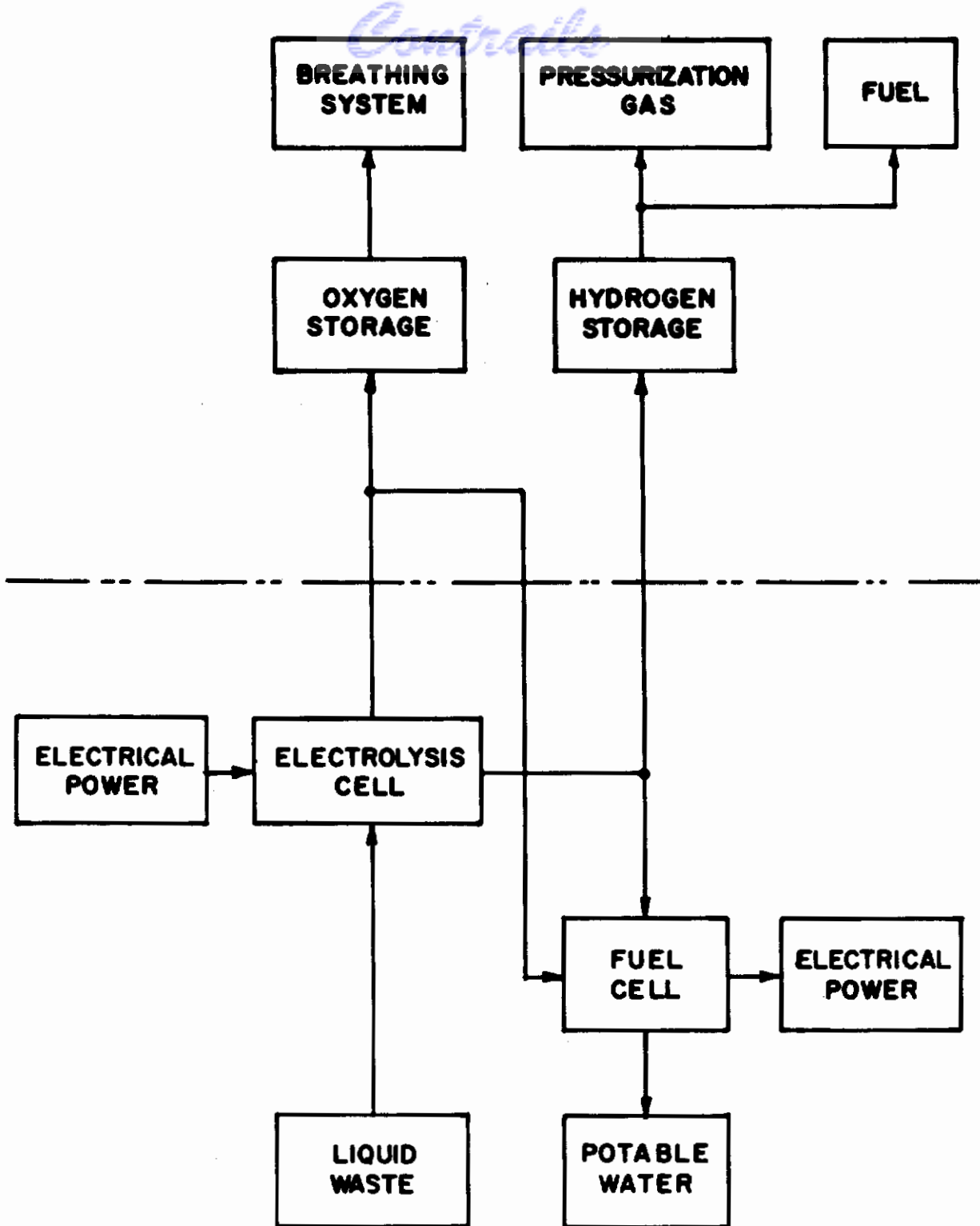
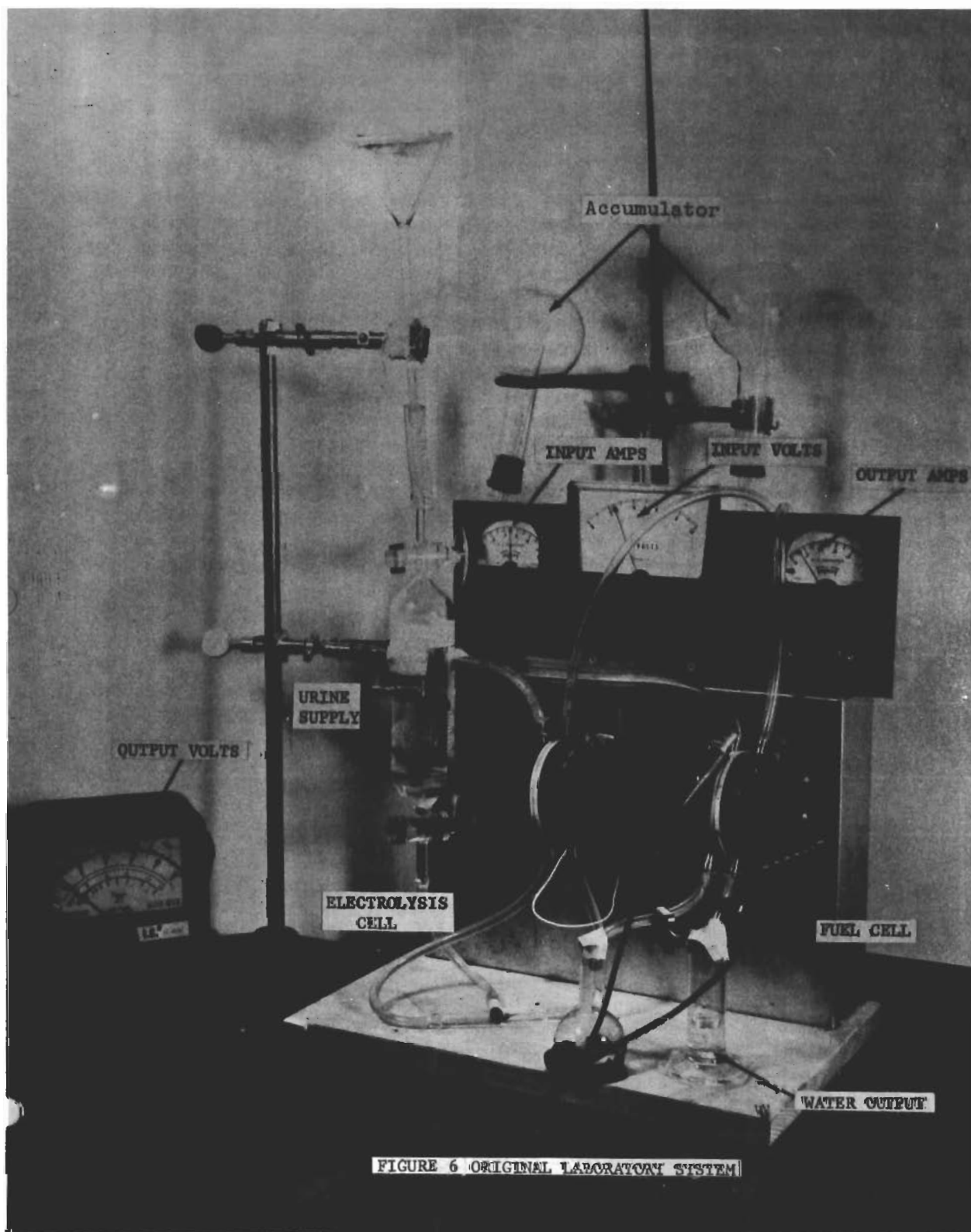

Figure 4. Ion-Membrane Electrolysis Cell



**FIGURE 5. ELF SYSTEM (ELECTROLYSIS-FUEL CELL SYSTEM)
BLOCK DIAGRAM SHOWING SYSTEM FLEXIBILITY.**



Contrails

2. Zero G design characteristics can be made an inherent part of the basic design, i.e., liquid/vapor separation.
3. High reliability - design need contain no moving parts, and its inherent characteristics can be readily adaptable to fail-safe philosophies.
4. Reasonable operating temperatures, weights, volumes, power requirements, efficiencies, life, maintenance requirements, and yields can be expected.

Since the fast evolving IEM research and development activities have been primarily oriented toward fuel cell optimization for the production of power, it was necessary to determine for the ELF technique the extent of adaptability of the IEM R and D activities.

The extent and nature of additional R and D needs also had to be determined before specific feasibility for manned space vehicle use could be evaluated.

The general questions to be answered were:

1. What are the latest IEM developments?
2. Could they be used in the ELF application?
3. If so, how could they be used to produce potable water?
4. What modifications would be needed?
5. What innovations were required?
6. Would these increase or decrease the degree of desirability for intended use?
7. What IEM features and characteristics will improve the competitive position of ELF with other water reclamation systems?

The specific problems and required determinations that could provide answers to these questions directly and indirectly, are listed in the following outline. Cognizance of the nature and extent of these was provided by General Electric Company experimental work prior to this program, and the early work in the program itself.

Contrails

1. Subsystems and Components

a. Electrolysis

- (1) foaming
- (2) membrane life
- (3) catalyst life
- (4) dilution of electrolyte
- (5) maintainability of triple point contact between catalyst, membrane, and electrolyte and effects and nature of degradation.

b. Fuel Cell

- (1) operating life
- (2) effects and nature of leaching of electrolyte
- (3) size

c. Membranes

- (1) Zerolit Phenolic membranes - application
- (2) Phenolsulfonic-acid based membrane-application

d. Electrode-Catalyst

- (1) life
- (2) contamination
- (3) electrode-membrane integration

2. System

a. Efficiencies

- (1) Electrical (electrolysis)
- (2) Chemical
 - (a) percent conversion to gas
 - (b) percent reconversion to water

b. Operating Characteristics

- (1) Electrolysis Cell
 - (a) power required (current-voltage relationships)
 - (b) electrolyte concentration
 - (c) temperature
 - (d) circulation
 - (e) zero G operation
 - (f) operating pressure
 - (g) life
 - (h) gas composition and purity
 - (i) effects of scaleup
- (2) Fuel Cell
 - (a) current-voltage relationships
 - (b) power density
 - (c) effect of electrolytic gases on life
 - (d) power output
 - (e) water recovery

Contrails

- 1 chemical and bacteriological potability
- 2 percent recovery
- 3 zero G recovery
- 4 trace contaminants
- (f) temperatures
- (g) pressures
- c. Design factors
 - (1) Zero G operation
 - (a) sub assemblies
 - (b) transition stages
 - (c) integration
 - (2) Weight
 - (3) Volume
 - (4) Power
 - (a) requirements
 - (b) utilization
 - (5) Fail-safe operation
 - (6) Adaptability to expansion

The following sections provide specific data and discuss in more detail the nature, theory, conduct, results, and conclusions of the program "Research on Electrolysis Cell-Fuel Cell Method of Recovering Potable Water from Urine", the first significant efforts directed toward determining the specific feasibility of the ELF system for manned spacecraft.

APPROACH

To conduct this research program in its most meaningful manner required three major activities:

1. Research and experimentation to determine characteristics of state-of-the-art components, and to generate original concepts and innovations that will improve performance and/or resolve system problems. Operation of a state-of-the-art type system also provides "base line" criteria to which improvements and requirements could be measured.
2. Laboratory evaluations of improved preliminary system designs resulting from the activities in (1) provided up-to-date criteria and test data of a system specifically oriented for the intended end-item use, i.e., production of potable water.
3. Based upon the efforts and data of (1) and (2) reasonably accurate projections of flight prototype system characteristics and performance

Contrails

were established. These then were used in trade-off studies to parametrically determine the degree of preference the ELF system offers when compared with other water recovery systems.

Accordingly, integrating and evaluating the results of these combined activities provides a clear picture as to the ELF system feasibility for Spacecraft use.

Contrails

SECTION III

DESIGN ANALYSIS

Previous sections have briefly presented the general characteristics of the program concept. This section, Design Analysis discusses those theoretical considerations pertinent to the conduct of the required research and experimentation for achieving the program's objectives.

FUEL CELL THEORY

The phrase "ion-exchange membrane cell" refers to fuel cells that employ ion-exchange polymers in sheet form as all or part of the electrolyte. Drawing on the ion-exchange polymer technology developed primarily for water treatment, a wide variety of materials has been studied as fuel cell electrolytes, (Ref. 3). Three main lines of development can be identified:

Inorganic ion exchangers in heterogeneous membrane structures, either leached or equilibrated with aqueous electrolyte.

Dual organic membrane structures with aqueous electrolyte in the "pocket" between the membranes.

Leached organic ion-exchange polymer membranes as the sole electrolyte.

Leached Organic Membranes

For various reasons which need not be discussed here, only leached organic membranes fully realize the advantages of the ion-exchange polymer as a fuel cell electrolyte. These advantages include: ruggedness, ease of construction, system simplicity, electrolyte behavior independent of gravity, and absence of concentration polarization effects (i.e., concentration gradients). System simplicity comes about primarily because pure water is the only liquid that needs to be handled in order to maintain the electrolyte water content. The structural strength provided by a good membrane material permits the use of very thin electrode structures. These thin electrodes minimize the mass transfer problems associated with rejecting product water in vapor phase and with accumulation of inerts in the pore structure of thicker electrodes. Capitalizing on these factors the ion-exchange membrane hydrogen oxygen cell has been brought to an advanced state of development by the General Electric Company.

Membrane Electrolytes

A study of the various chemical factors that influence the conductivity of ion-exchange polymer has been carried out by Grubb, Hodgdon and Niedrach, (Ref. 4). On the surface, the fact that the conductivity of ion-exchange materials is less than that of sulphuric acid or potassium hydroxide solutions of appropriate concentrations would seem to be a serious disadvantage. In practice, however, this limitation is readily overcome by use of membrane electrolytes which are thinner than is feasible with liquids. The greater thermal stability and higher conductivity of cationic membranes has resulted in the almost exclusive use of sulfonic acid ion-exchange materials.

Functional Mode

Static heads of hydrogen and oxygen (10 to 100 psia, $\Delta P < 5$ psi) are supplied to anodic and cathodic sides of the cell, respectively. Hydrogen is chemisorbed on the catalyst in the anode and becomes ionized, releasing free electrons. When the external circuit is closed, these electrons will flow from anode to cathode. The hydrogen ions or protons are exchanged from one SO⁻ group to the next in the fixed polymer structure. The protons (H⁺) are hydrated (H₃O⁺) and carry with them water molecules (H₂O) to the cathode (H⁺ + H₂O = H₃O⁺). This "pumping" effect is balanced by back diffusion (H₂O)_d of water from the cathode. At the cathode, oxygen is chemisorbed on the catalyst but the reaction steps which occur in the complete process are not fully understood. The overall reaction results in the combination of the hydrogen ions with the oxygen and the electrons from the load to form water.

The standard heat of formation of liquid water from gaseous hydrogen and oxygen is 17.0 kwhr/LbH₂. From 45 to 75 percent of this can be realized as useful electrical energy, depending on the cell voltage, while the remainder appears as heat in the membrane. The necessary removal of this heat and the product water is accomplished in the mechanical design of the fuel cell module discussed in the system design sections of this report.

From an engineering point of view, one of the most important characteristics of an ion-membrane fuel cell is that the molecular diffusion through it at one atmosphere is negligible. Total diffusion is 4×10^{-4} ft.³ of hydrogen per hour per square foot of membrane which is equivalent to about 0.025 amp/ft.². Electron current efficiency is essentially 100%. Therefore, the hydrogen, oxygen and water rates per cell can be calculated from Faraday's law, (Ref. 5).

$$w = \frac{Ie}{F} \text{ lb/hr} \quad (1)$$

Contrails

where I is current, e is equivalent weight of reactant and \mathcal{F} is Faraday's constant:

$$\begin{aligned}W_H &= 0.08292 \times 10^{-3} \text{ lb/amp-hr} \\W_O &= 0.65796 \times 10^{-3} \text{ lb/amp-hr} \\W_{H_2O} &= 0.74088 \times 10^{-3} \text{ lb/amp-hr}\end{aligned}$$

ELECTROLYSIS THEORY

The electrolysis of water to form hydrogen and oxygen is a classical reaction which has been well studied and therefore is comparatively well understood. The overall reaction may be represented by the following equation:

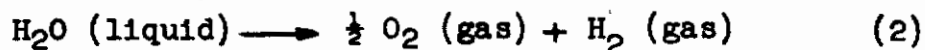

To accomplish the reaction shown above, D.C. electrical power is passed through an electrolyte (water and sulphuric acid for the ELF System) between two platinum electrodes. It is this same reaction in reverse order that is the basis for power production in a standard hydrogen-oxygen fuel cell. The power requirements for this reaction are best explained by the thermodynamic relationships of the standard free energy change, ΔF^0 . From the standard free energy of the reaction one may evaluate the theoretical equilibrium reaction potential required for the reaction to take place reversibly at constant temperature and pressure. This relationship for the standard potential (electrode) E^0 , of the cell is represented as follows:

$$E^0 = -\frac{\Delta F^0}{n \mathcal{F}} \quad (3)$$

where

E^0 = the standard potential (electrode)

ΔF^0 = the standard free energy change

n = the number of equivalents liberated at either electrode

\mathcal{F} = Faraday constant

Therefore, knowing the standard free energy change for the reaction shown, it becomes possible to determine the minimum theoretical electrode potential required for the dissociation of water. This potential has been determined to be 1.23 volts at 77°F and 1 atmosphere. For an electrolysis rate of 10 pounds of water per day (approximating a 3-man urine output) a theoretical power input of 230 watts per man is required. The standard free energy change of the reaction, however, does not represent the total energy requirement for the dissociation

Contrails

of water. The standard free energy change must equal the corresponding change in heat content less the heat exchange with the surroundings when the electrolysis cell is operated reversibly and isothermally at constant pressure. This relationship between the standard free energy, change in heat content and heat exchange with the surroundings is expressed as follows:

$$\Delta F^{\circ} = \Delta H^{\circ} - T\Delta S^{\circ} \quad (4)$$

where

ΔH° = standard enthalpy change

T = absolute temperature

ΔS° = standard entropy change

The additional energy requirement is represented by the $T\Delta S^{\circ}$ term where, as in most cases this shows up as heat, in this case added to the system. Thus, the energy balance shows that for the theoretically reversible reaction, an energy input of 45.4 watts per man is required in addition to that energy previously quoted thereby providing a potential cooling capacity as an inherent characteristic of the reaction.

Unfortunately, however, the actual voltage required is considerably higher than the minimum theoretical voltage due to characteristics inherent in any operating electrolysis cell. These losses are caused by electrical resistance, polarization, and electrode overvoltages which are more than sufficient to make up for this apparent energy deficiency.

Decomposition Voltage

If two small sheets of smooth platinum are immersed in dilute sulphuric acid and a gradually increasing E.M.F is applied by means of an external battery, so as to electrolyze the solution, a galvanometer in the circuit will show that the current increases in the manner represented by the curve in figure 7, (Ref. 6). It appears that an appreciable voltage must be applied before current can flow freely through the cell. The E.M.F. applied at the point "D" at which steady state electrolysis commences, is called the decomposition voltage of the particular solution, with the given electrode material. It is at this point that, in general, the steady evolution of hydrogen and oxygen gas bubbles is observed. Attention should be drawn to the fact that the nature of the current voltage curve in figure 7 is such that "D" cannot be identified precisely; in any event it is now believed not to have any exact theoretical significance. The apparent decomposition voltage is, however, of specific interest

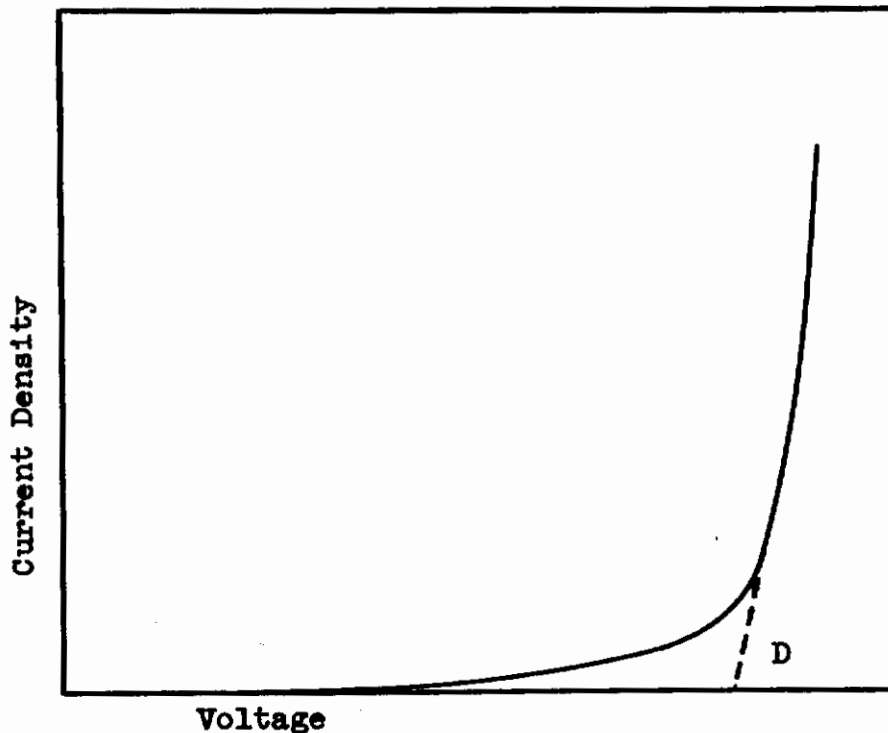

Figure 7 Decomposition Voltage

in this program for it provides an approximate indication of the minimum E.M.F. which must be applied to a particular solution in order that currents of appreciable magnitude shall be able to flow. It represents the sum of the potentials which must be attained by the two electrodes before the rates of the respective ion discharge processes become appreciably greater than the reverse reactions.

The decomposition voltages of aqueous solutions of acids have been systematically studied and provided strong evidence that the same electrolytic processes occurred at the electrodes in each case. The decomposition voltage reported for sulphuric acid was 1.67 volts. The fact that all other decomposition voltages reported for dilute aqueous solutions were approximately 1.7 volts led to the conclusion that the electrode processes were common to all systems tested. The chemical reaction which appears to be common to all aqueous solutions of acids and bases is the discharge of hydrogen ions at the cathode and of hydroxyl ions at the anode, or formation of hydrogen and oxygen, respectively.

Overvoltage

The theoretical voltage required for the reversible decomposition of an aqueous solution of an acid or base is equal to the E.M.F. of the reversible cell with hydrogen and oxygen gases at 1 atmosphere pressure; this is known to be about 1.23 volts irrespective of the nature of the electrolyte provided, of course, that it is the same throughout the cell. The fact that the observed decomposition voltage is much larger than the theoretical (reversible) value means that the flow of an appreciable current, requiring the discharge of hydrogen ions at appreciable rates, is accompanied by a relatively large polarization. This polarization depends upon the nature of the electrodes as shown by decomposition voltages reported for various electrode materials including platinum electrodes (two) in a dilute sulphuric acid system. The decomposition voltage approaches 1.7 volts for the previously mentioned system. Detailed studies of this problem made in the past provided data on the potentials at which visible evolution of hydrogen and oxygen gases occurred at cathodes and anodes, respectively, of a number of different metals. The difference between the potential of the electrode when gas evolution was actually observed and the theoretical value for the same solution was called the overvoltage (or overpotential).

Reported data is usually presented as "bubble overvoltage" corresponding to the point at which gas bubble formation commences. In practice the excess potential is measured at a definite current density (current per unit area of electrode surface) usually at the point represented as "D" in figure 7. Of data reported, it was shown that only for a platinized platinum cathode does the evolution of hydrogen occur in the close vicinity of the reversible potential in an acid solution. Overvoltages reported for platinum electrodes (at a current density of 0.01 amps/sq.cm.) are 0.005 volts for platinized platinum and 0.09 volts for smooth platinum, the significant factor being surface effects (i.e., roughened surfaces appear to present a lower overvoltage than a smooth surface of the same metal). The nature of this effect is not immediately apparent but may be caused in part by an increase in the effective area with the subsequent decrease in actual current density. In addition, as temperatures are raised, overvoltages tend to diminish as a result of increased ionic mobilities (which in turn decrease concentration gradients).

Oxygen overvoltages are not as readily studied due to the unsteady state conditions which exist at the anode. Reported values for oxygen overvoltages are of the order of 0.25 volts for platinized platinum and 0.45 volts for smooth platinum electrodes.

Contrails

Based upon the previous discussion it would appear that the actual minimum decomposition voltage for a dilute aqueous sulphuric acid solution will be 1.23 volts (theoretical)+ 0.005 to 0.009 volts (hydrogen overvoltage)+ 0.25 to 0.45 volts (oxygen overvoltage) or an overall E.M.F. in the range of 1.485 to 1.77 volts.

Resistance Losses

Losses due to internal resistances are the result of cell characteristics such as contact resistances between collector and electrode, or electrode and electrolyte, and electrolyte conductivity. These constitute the major contributors to resistance losses.

The first of these factors, contact resistances, are primarily a function of IEM cell design and construction. For the collector-electrode interface, contact pressures and contact areas become increasingly important factors. Pressure must be sufficient to maintain good contact yet not enough to cause damage to the electrode structure. The effects of area must be carefully evaluated to provide sufficient contact area yet leave adequate reaction area exposed to support the reaction rates required. Obviously the inter-actions of these factors must be carefully considered when designing and constructing the cell.

The electrode-electrolyte interface also poses problems for the designer since these contacts must be intimate enough to provide chemical reaction sites as well as good electrical conductivity. This contact is also affected by gases evolved during operation since the gas bubble generated reduces the effective contact area, thereby increasing the cell resistance.

Electrolyte conductivity is also important since, as previously explained, ion transfer mechanisms are necessary to provide the electrical continuity through the cell. Whether the electrolyte be solid or liquid, ionic mobilities are a function of electrolyte composition, concentration, and temperature. In the case of the solid electrolyte, characteristic of the GE-IEM, electrolytic conductivity is accomplished by the introduction of dissociable ionic groups chemically bonded to the basic cross-linked polymer structure of the membrane. Specifically, the membrane used in this program is a sulfonic acid polymer. This material in the acid form will conduct electricity solely by movement of hydrogen ions across the membrane since the sulfonate ion-- (SO_3^-) is rendered immobile by attachment to the polymer.

The resistivity of this material is greatly

Contrails

enhanced by equilibration with strong liquid electrolytes. When the ion exchange membrane is immersed in an electrolyte solution, some of the electrolyte diffuses into the gel water of the membrane. (Some water transport also occurs during operation as a result of ion transfer processes since all ions are thought to be hydrated, and because of the potential difference across the membrane). The higher the concentration of electrolyte in the gel phase, the greater is the conductivity of the cell (depending, of course, upon the conductive characteristics of the electrolyte used).

Liquid electrolyte systems are similarly affected by electrolyte concentrations, compositions, and temperatures. Since the electrolysis of water generally involves liquid systems, these characteristics are worthy of consideration at this point. The remarks presented here are limited to sulphuric acid systems for reasons which shall become obvious later; these comments, however, are applicable to alkali hydroxide electrolyte systems (eg., KOH) as well.

Liquid electrolyte electrical characteristics are usually discussed in terms of conductivities rather than resistances. Conductivity is the reciprocal of specific resistance which in turn is defined as the resistance of a unit cube of a conductor of a given material expressed in ohms per centimeter cube or ohms/inch cube. (or more commonly, ohm cm. or ohm/inch for a conductor of unit area).

The conductivity of a solution is a function of the nature of the electrolyte (size and charge of the ions), the solvent, the concentration, and the temperature. Conductivity varies directly with concentration up to a maximum point, after which there is a decrease. The curves shown in figure 8 show this relationship between specific resistance (or resistivity) and equivalent conductivity as functions of electrolyte concentrations at a specific temperature. The equivalent conductivities of sulphuric acid were obtained from reported data and conductivities and resistivities were calculated from the following relationships:

$$\Lambda = KV \quad (5)$$

$$K = \frac{1}{\rho} \quad (6)$$

where

- Λ = equivalent conductivity, ohm⁻¹ cm⁻¹
- K = conductivity, ohm⁻¹ cm⁻¹
- ρ = resistivity, ohm cm
- V = volume cm³

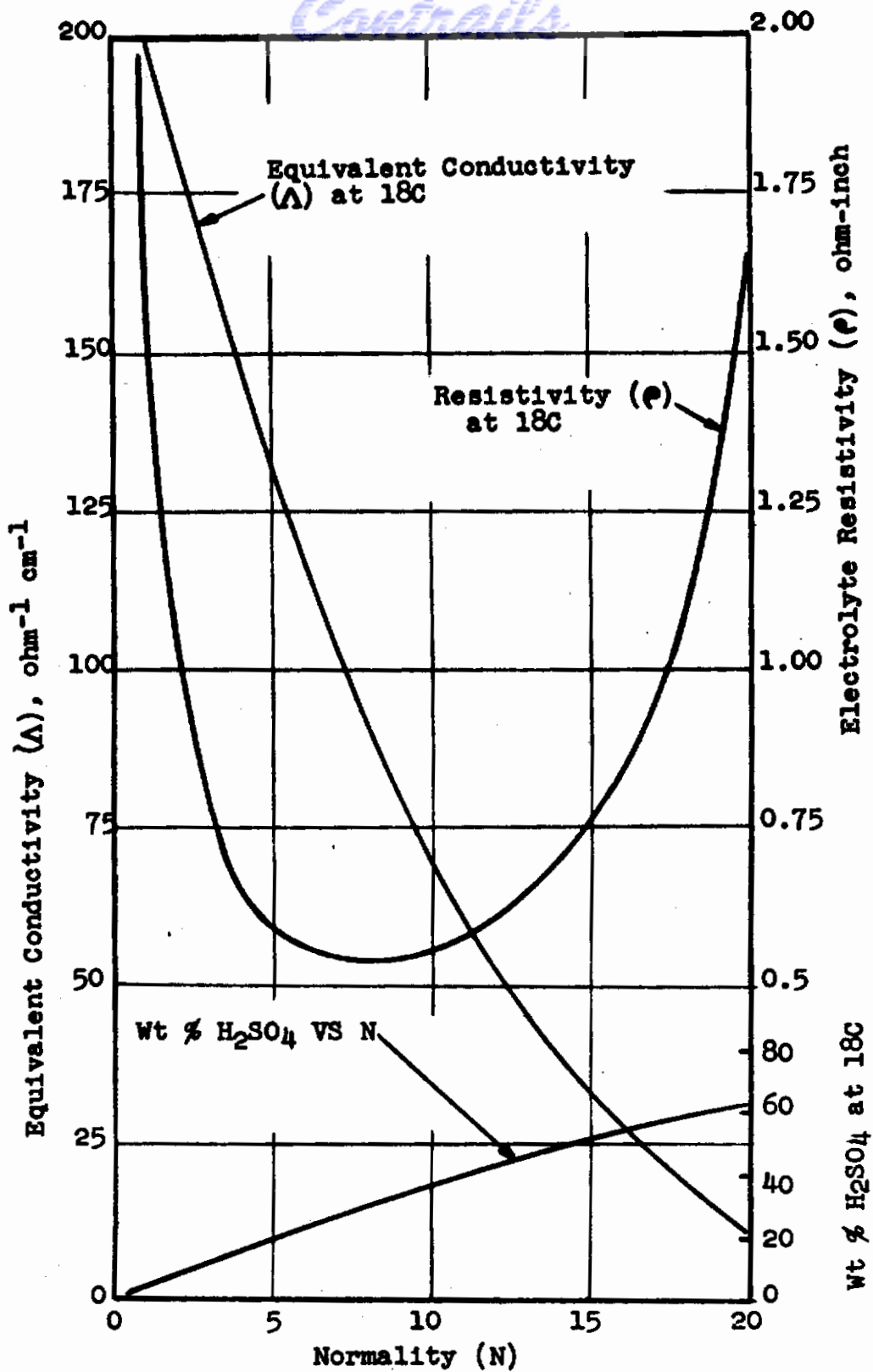

Figure 8 Effect of Electrolyte Concentration on Resistivity

Contrails

Combining equations (5) and (6) the expression for resistivity in ohm inches becomes:

$$\rho = \frac{1000}{2.54 \wedge N} \quad (7)$$

where

N = normality of the solution.

The results of these computations as presented in figure 8 show that the minimum resistivity (hence the minimum resistance to current flow) of aqueous solutions of sulphuric acid occurs at a concentration of approximately 32 percent.

The effects of temperature on electrolyte resistivity may be easily determined from these curves and the following empirical relationship, (Ref. 7):

$$K_t = K_{18} [1 + b (t - 18)] \quad (8)$$

where

K_t = conductivity at desired temperature

K_{18} = conductivity at 18°C

b = empirically determined temperature coefficient (0.01 - 0.016 for acids)

The results of this determination are shown in figure 9 for a 20 percent sulphuric acid solution. From this data resistances for specific electrolyte systems may be calculated. The applicability of this relationship will be shown in a later section. It is important to note at this point that liquid electrolyte system resistances are a direct function of temperature and as such can be reduced slightly by proper selection of operating temperatures for increased efficiencies.

THE ELF SYSTEM THEORY

Theoretical considerations of the ELF concept are basically an integration of the fuel cells and electrolysis theories. Highlights of each has been previously presented. The ELF system brings these complimentary theories into practice in the following way. In the electrolysis module the water content of urine is electrolytically dissociated into hydrogen and oxygen gases. Fuel cells are then utilized to recombine these gases into water with the by-product of this reaction being electrical power.

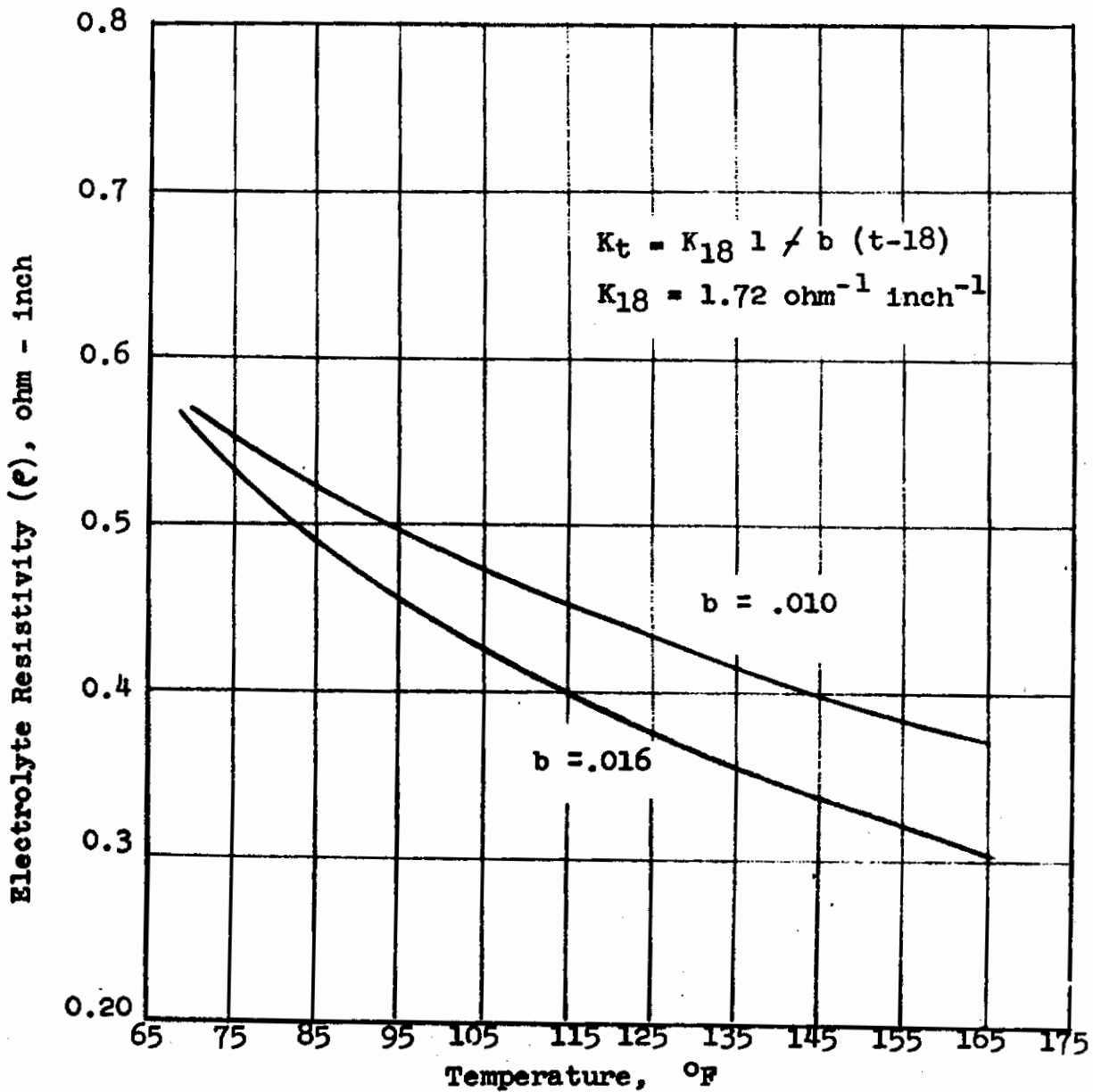

Figure 9 Effect of Temperature on Electrolyte Resistivity for 20 % H₂SO₄

Energy Balance

Were it possible for the chemical reaction to be carried out at its theoretical voltage in both instances, the net power requirement for the system would then be zero. However, as in all real systems irreversibilities are present which prevent operation at 100 percent efficiency. From the electrochemical data previously shown, the theoretical decomposition voltage of water was 1.23 volts. Considering electrical resistances, overvoltages, polarization, etc., the minimum decomposition voltage becomes approximately 1.49 volts for platinum electrodes in acid systems.

In fuel cell systems where electrical power is generated these inefficiencies act to decrease the output voltage so that with negligible current flow the maximum cell voltage is approximately 1.0 volts. These figures then may be used to determine the electrical efficiency of an optimum system, that is, one where electrolysis is carried out at a potential of 1.49 volts and the fuel cell operates at 1.0 volts. Were these systems to function in this manner, it then becomes possible to recover in the fuel cell approximately 62 percent of the power used by the electrolysis cell. Analytically, the ELF system power requirements are shown to be 31.6 watts per pound of potable water recovered per day.

Material Balance

It should be noted that the efficiencies discussed above are electrical efficiencies and are not a measure of the chemical reaction efficiencies of the system. As previously noted chemical reaction efficiencies for IEM cells are essentially 100 percent. Deviation from this theoretical efficiency is represented by material losses from the system which then go unreacted. This loss in the fuel cell is due to diffusion of hydrogen gas through the membrane, which corresponds to a loss of approximately 0.025 amps per square foot of membrane area. For a fuel cell operating at 50 amps per square foot (normal long term operating point) this amounts to a loss of approximately 0.05 percent of the total gas input, leaving 99.95 percent of the gas to be reacted. Material losses in the electrolysis cell are limited to water vapor carried by the gases, which again is an extremely small figure. This vapor is not really lost, however, since all water generated in the fuel cell module is collected for use.

Looking at an overall material balance for the ELF system recovering potable water from urine we find that the recoverable water in urine represents approximately 95 percent of the total weight. The chemical breakdown of urine is shown in table 1, (Ref. 8). Recovery of this quantity of water (3.1 pounds per man day) represents enough to supply a man's drinking water requirements from his urine output, an ideal situation in closed ecological systems. For a 3-man system

Table 1

COMPOSITION OF A TYPICAL NORMAL URINE *

	<u>Units</u>
Water	1200.0
Solids	60.0 - 5%
Urea	30.0 - 2.5%
Uric Acid	0.7
Hippuric Acid	0.7
Creatinine	1.2 - 0.1%
Indican	0.01
Oxalic Acid	0.02
Allantoin	0.04
Amino Acid Nitrogen	0.2
Purine bases	0.01
Phenols	0.2
Chloride as NaCl	12.0
Sodium	4.0 - 0.33%
Potassium	2.0 - 0.166%
Calcium	0.2 - 0.0166%
Magnesium	0.15 - 0.0125%
Sulfur, total, as S	1.0
Inorganic sulfates as S	0.8
Neutral sulfur as S	0.12
Conjugated sulfates as S	0.08
Phosphate as P	1.1
Ammonia	0.7

* NOTE: For more complete listing of constituents see Ref. 13.

Contrails

the water recovery balances show that the ELF system can recover almost nine and a half pounds of potable water from the daily urine output of the crew. Recovery of this water would be at a minimum cost of 284 watts of electrical power.

Heat Balance

Analytical treatment of heat balances for the ELF system show that the electrolysis module will require an addition of heat energy to maintain isothermal operating conditions. This heat energy requirement amounts to 35.9 watts per man on a continuous basis. On the other hand, fuel cell module operation requires removal of excess heat for isothermal operation. The heat energy generated by the fuel cells is approximately 48 watts per man, nearly the same as that required by the electrolysis module. Therefore, the net heat balance for the system requires removal of approximately 12 watts of heat per man (40.8 BTU/hr./man).

ENERGY AND MATERIAL BALANCE

The energy and material balances previously discussed are most easily summarized in the form of a system schematic. Figure 10 is a diagrammatic representation of the theoretical aspects of the ELF system. It is interesting to note that the functional subsystems are nearly complimentary in most performance characteristics.

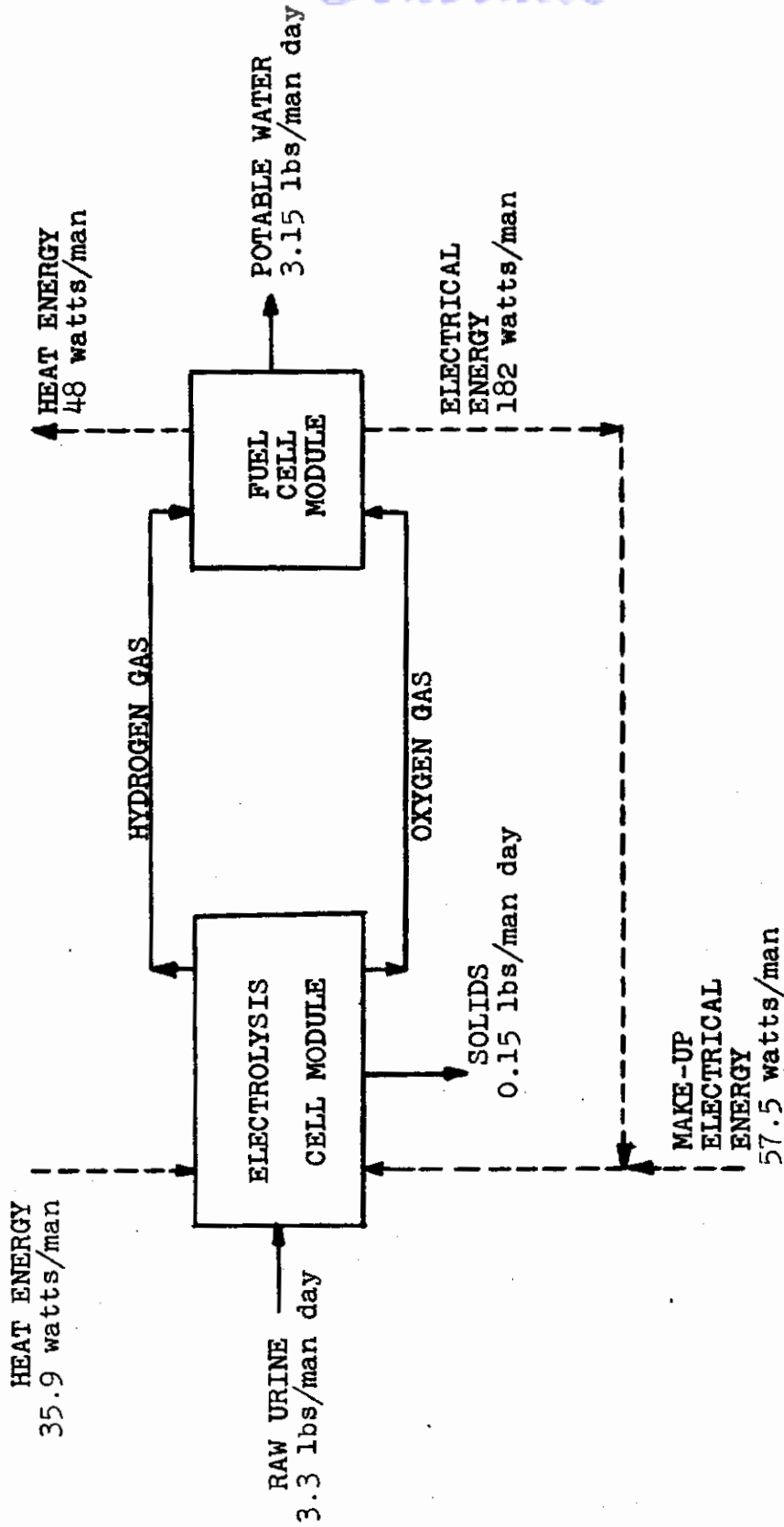

FIGURE 10. THEORETICAL ENERGY AND MATERIAL BALANCES FOR ELF WATER RECOVERY SYSTEM.

SECTION IV

RESEARCH AND EXPERIMENTATION

Experimental phases of the program were concerned with evaluation of the IEM Electrolysis Cell-Fuel Cell Concept for recovery of potable water from urine. Following preliminary results of the design analysis, the areas requiring extensive laboratory examination were more specifically defined. As previously anticipated, the areas of prime concern were development and testing of electrolysis cell designs, operation of fuel cells in conjunction with electrolysis cells, and accumulation of data concerning the electrolysis of urine, and product water quality.

PRELIMINARY EXPERIMENTS

As a prelude to actual testing of IEM cells, preliminary tests were performed using standard platinum foil electrodes in aqueous sulphuric acid solutions. The objective to be accomplished by operation of platinum foil electrolysis cells was to obtain data on product gas compositions for subsequent comparison with gases generated by the IEM cells. Figure 11 is a photograph of the laboratory test system which provided for liquid level control, gas sampling, pressure regulation and indication, and gas flow indication.

Gases were collected from the electrolytic decomposition of water, and raw urine in 20% sulphuric acid solutions. These were analyzed with a Consolidated Electroynamics Corp. Mass Spectrometer to determine the presence of gross contaminants. Generally, the operating test procedure followed was:

1. Charge Cell and supply bottle with solution to be tested.
2. Start up cell, maintain voltage at $1.7 \leq E \leq 2.0$ volts.
3. Let system reach equilibrium, allowing gas to purge collection lines and bottles.
4. Collect samples under positive pressure (approx. 2 inches water).
5. Submit for analysis

Gas output rates for these cells were small due to the relatively small electrode areas, thereby requiring comparatively long periods of time for purging and sample

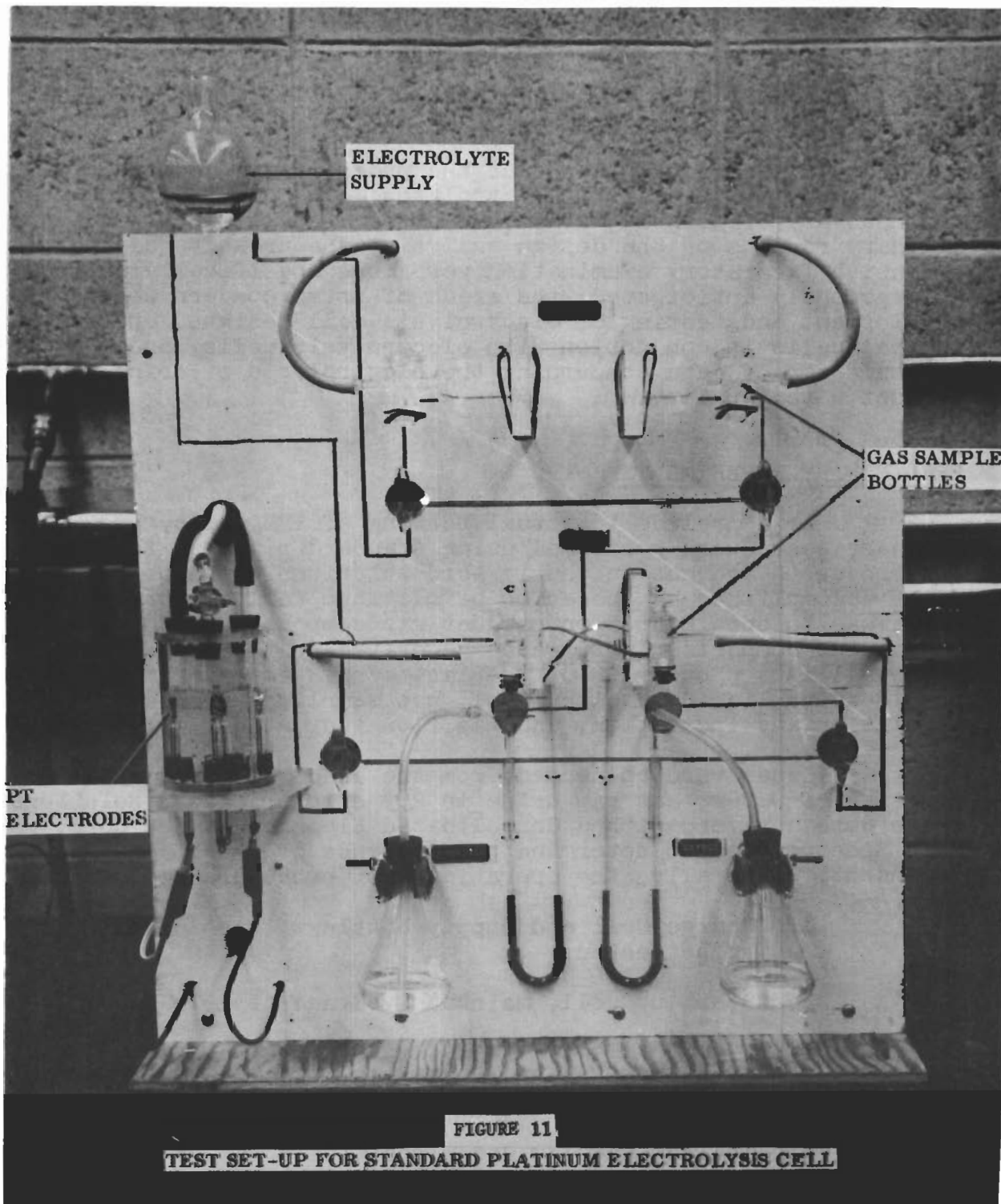

Contrails

collection (increasing chances for gas leaks and contamination). For this reason a minimum number of samples were obtained and analyzed. Indications were that comparatively high purity gases (i.e., >95 percent purity) were generated from water, while the electrolysis of urine showed high carbon dioxide concentrations (total contaminants to 20 percent). More precise data, other than the indications shown here were not sought since only gross gas contaminants were of interest at this time.

COMPONENT/SUBSYSTEM EVALUATION

Laboratory testing and evaluation of major ELF components was organized, to provide the maximum test data under various operating conditions. For program economy, laboratory glassware and instrumentation were used wherever possible. Sizing of the test cells was dictated by the size of membrane assemblies and current collectors presently available from limited pilot plant production.

Since little was known about the use of ion-exchange membranes operating continuously in the electrolysis mode, the ELF test program planning called for an orderly progression from simple, single cell control tests to more complex, multi-cell electrolysis modules. On the other hand, because of General Electric's testing and evaluation of fuel cell systems for power generation, considerable data (experimental and design) were available for integration with ELF test data obtained. Thus, testing of fuel cell assemblies was limited to evaluation of specific electrolysis cell-fuel cell integration problems such as effects of gas purity on power, life, etc., and quality of product water collected.

TEST PLAN

The test program objectives were to provide component performance characteristics, and ELF system performance characteristics (including the ultimate goal of recovering potable water from urine). To this end the experimental program included a series of single cell tests, multi-cell tests, and testing of single cell-multi-cell ELF combinations.

The single cell electrolyzer tests covered operation with distilled water, vacuum distilled urine and raw urine. These tests were run at various temperatures, electrolyte concentrations and electrolysis rates to determine the effects of these parameters on voltage-current relationships, cell life, gas purity, etc.

Contrails

Multi-cell electrolyzer tests were performed with single cell assemblies externally manifolded and single-cell assemblies physically integrated into modules. Again, performance characteristics were examined, gas samples analyzed, etc. to provide design data for the later phases of the overall program. It was during these tests that runs were made with raw urine for subsequent recovery of water for chemical and bacteriological analyses.

Fuel cells were tested primarily as single cell assemblies with major emphasis being placed upon evaluation of the effects of electrolytically generated gases on fuel cell performance. Effects of temperature and pressure, and wicking of water were also briefly examined to provide first hand knowledge of these operating characteristics.

SINGLE ANIONIC CELLS

Preliminary feasibility of the IEM electrolyzer was demonstrated in the laboratory prior to the formal beginning of this program. This was accomplished using anionic phenolic membranes which at the time represented the "state of the art" in regenerative fuel cell technology. The anionic membrane operates by movement of the hydroxyl ion through the membrane. The specific membranes used here were equilibrated in potassium hydroxide with the probable reaction mechanisms being as follows:

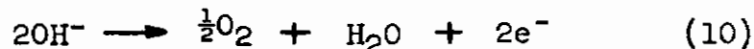
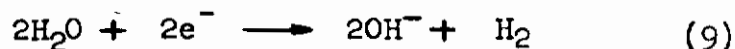

These represent the hydrogen and oxygen electrode reactions.

Cells used had an active membrane area of approximately 0.4 square feet in a 9 inch diameter cell. The cell assembly is shown in figure 12 showing the urine inlet and gas outlet lines. These cells were operated with distilled water, and distilled urine (both in 30 percent KOH solutions to prevent electrolyte dilution). The success of these laboratory test cells is shown by the curves in figure 13 showing the voltage current relationships for two runs. The curves represent electrolyzer operation on vacuum distilled urine. The relatively stable operation of run number 2 is believed due to cell modifications which permitted adjustment of electrode/membrane contact pressures, and increased electrolyte concentrations (to 30 percent KOH). As shown by the curves, cell life was substantially increased by these modifications to more than three weeks of operating time.

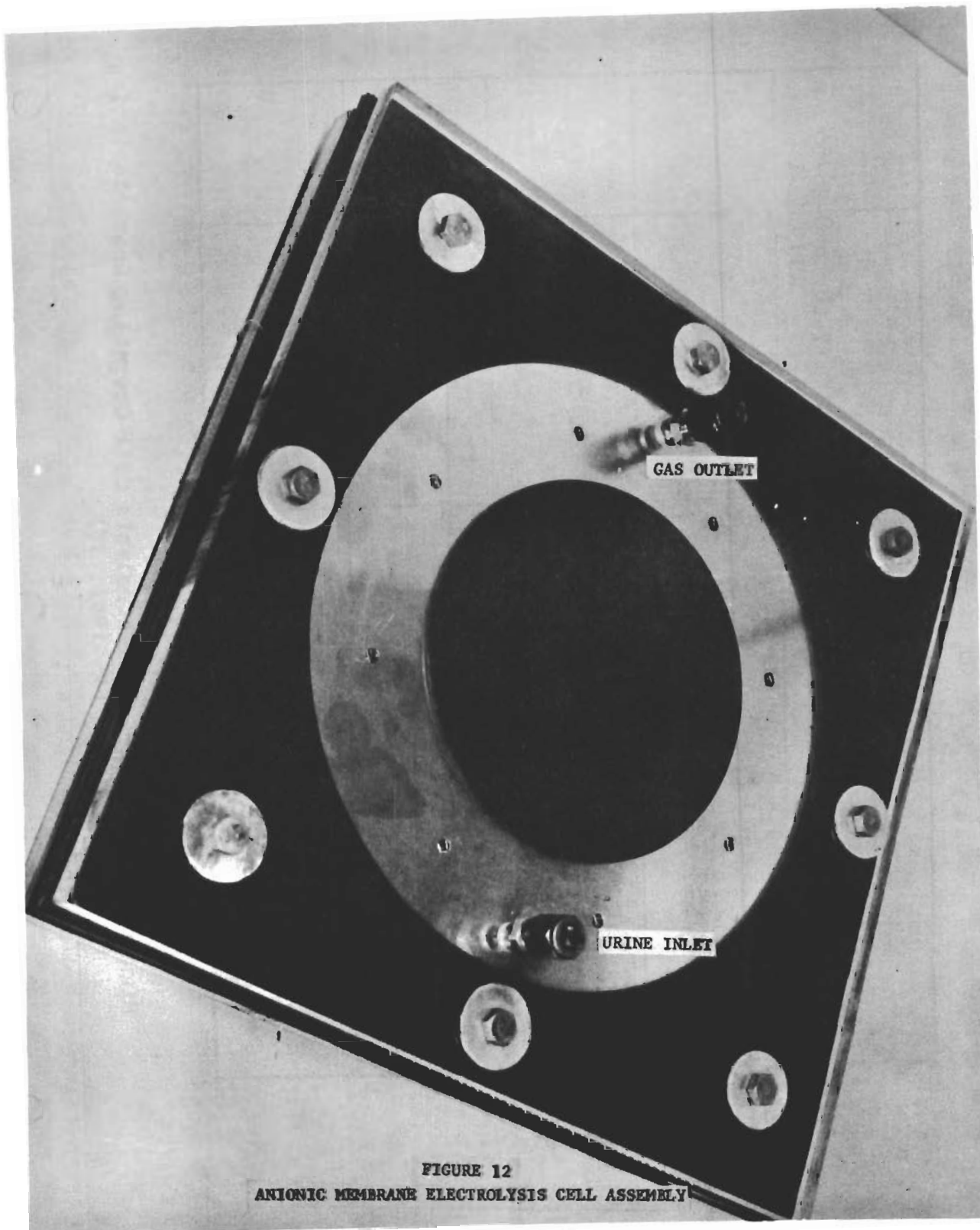

FIGURE 12
ANIONIC MEMBRANE ELECTROLYSIS CELL ASSEMBLY

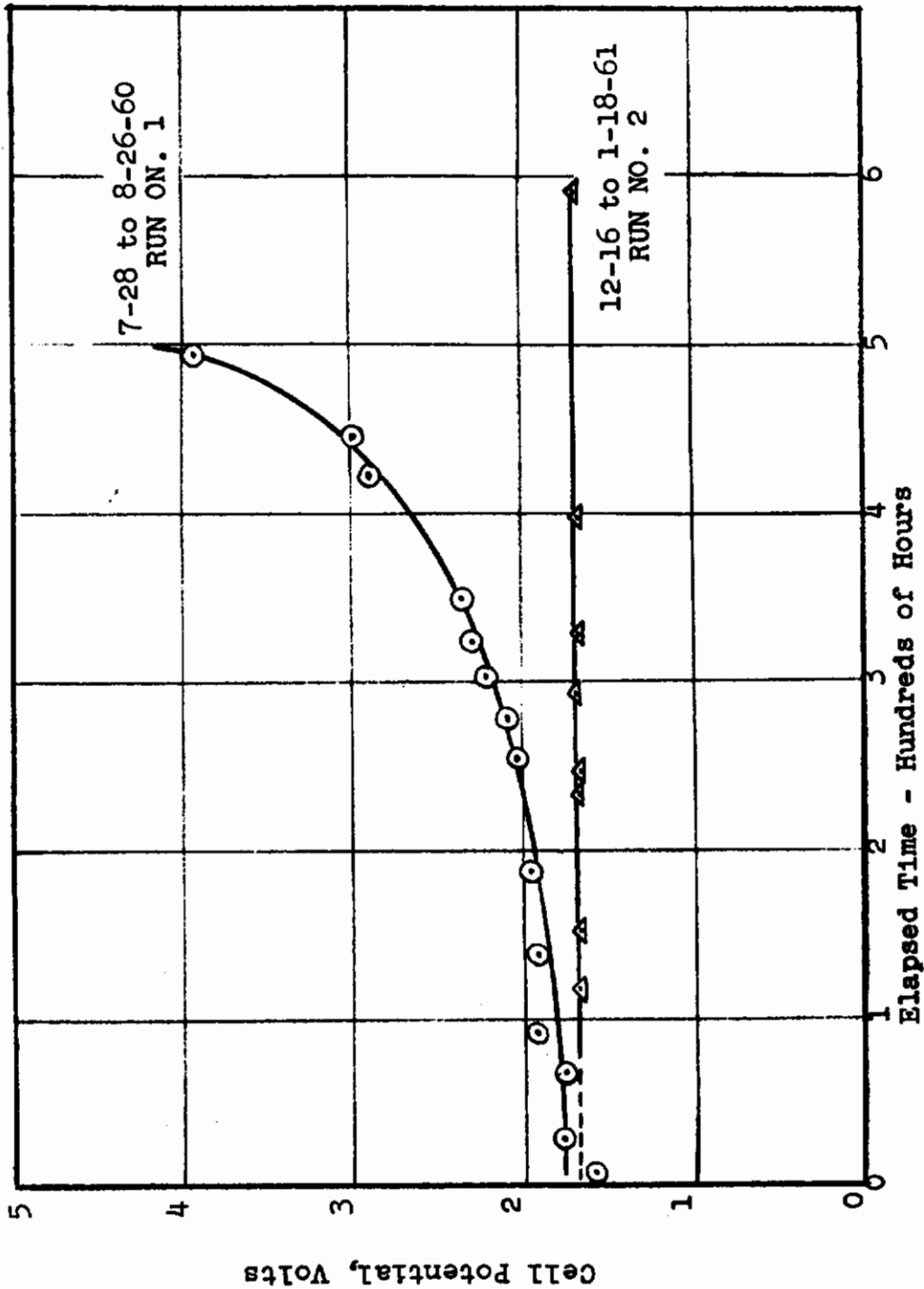

Figure 13 KOH Membrane Electrolysis Cell Operating Characteristics at 20 amps/ft² (Ref. 17)

Contrails

An electrolysis cell-fuel cell system was fabricated and tested to demonstrate preliminary feasibility of a practical size ELF system. The laboratory set-up is shown in figure 14 which shows the physical connections between the cells, the automatic liquid level controller and the instrumentation used. While gas generation/consumption rates were not checked during these tests the individual cells were operated at approximately the same amperage indicating good efficiencies. The set up was primarily for water collection.

Water collected from this system was tested by Betz Laboratories to determine the degree of conformance to the U.S. Public Health Drinking Water Standards. The quality of this water was good (see lab report Appendix A), in some cases superior to municipal supplies. There was a problem, however, with high KOH concentrations due to leaching of the fuel cell membranes. However, since it was evident that very little contamination was carried over from the electrolysis cell, this series of tests was concluded as clearly indicating the preliminary feasibility of the ELF concept for recovering potable water from urine.

SINGLE CATIONIC CELLS

During the time interval between the preliminary testing just described and the inception of the ELF Research program, considerable advances were made in fuel cell technology by the General Electric Company. These were manifest in cell construction techniques as well as membrane technology and were extremely helpful in the ELF laboratory program.

Advances in membrane technology made it obvious that the cationic or acid membrane was now more readily adaptable to the ELF System. Taking advantage of the competence built up within General Electric Company's fuel cell laboratories these new features were easily incorporated into the ELF System. Use of the acid membrane in both ELF subsystems had several advantages. The first of these was the availability of laboratory hardware for testing. In addition, directly applicable design data would be more readily available because of the development work being carried on. The non-leaching nature of the ion-exchange membrane was a prime consideration in the selection of this membrane for the fuel cell portion of the system. While all the advantages of acid-urine electrolysis systems were not immediately evident, as the tests progressed they were clearly disclosed.

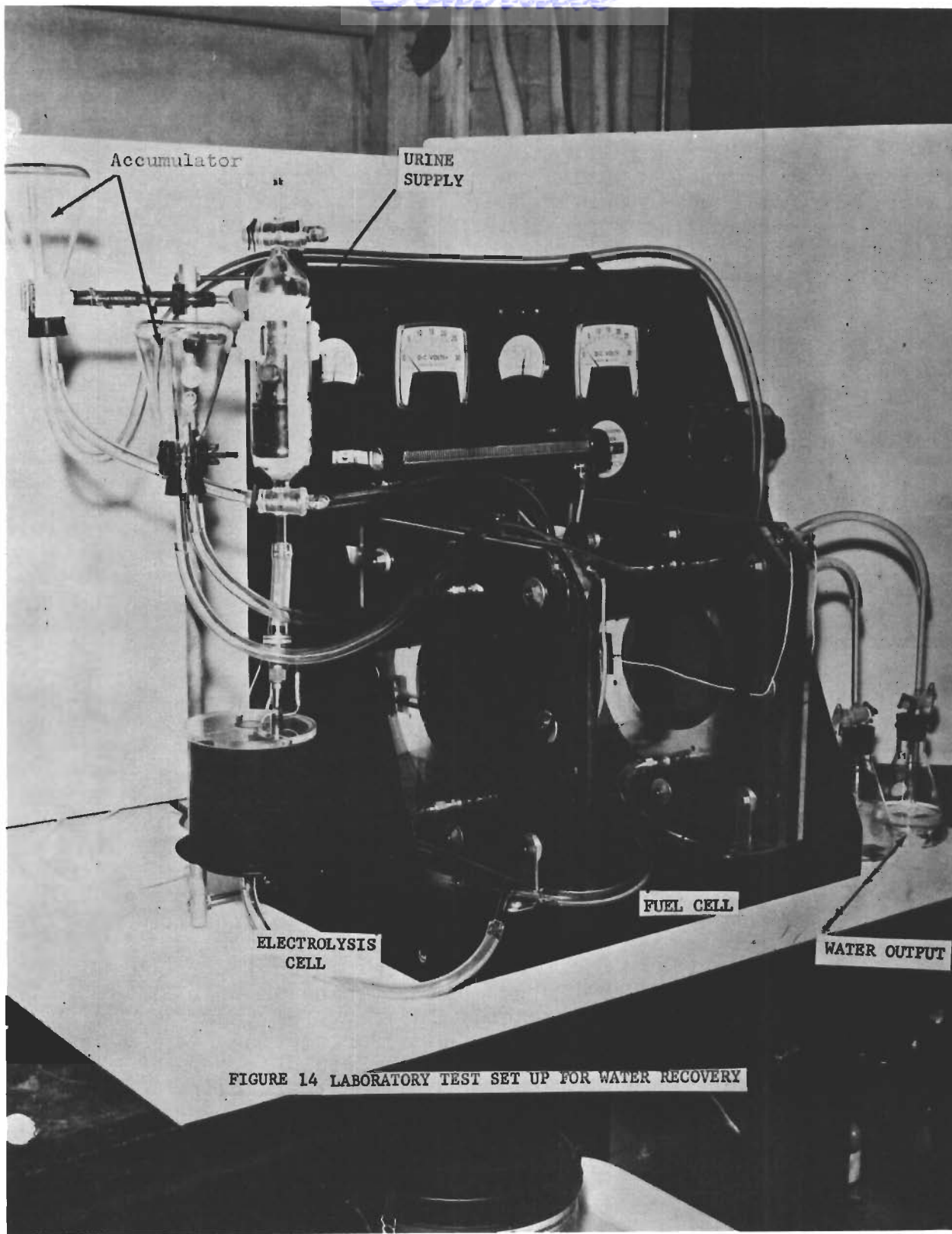

FIGURE 14 LABORATORY TEST SET UP FOR WATER RECOVERY

The test components were standard pilot plant production models from the General Electric Direct Energy Conversion Operation (DECO) in Lynn, Mass. The membrane/electrode assemblies had an active area of about 12 square inches (2" x 6"), the membrane being of the general class of sulfonic acid membranes designated by General Electric as the Polymer A prime series. The current collectors were standard Carpenter 20 steel which were gold plated to minimize corrosion problems in the electrolysis cells.

Electrolysis Cells

In keeping with the preliminary findings of the initial feasibility tests a single membrane assembly was fabricated and tested. This cell consisted of an ion exchange membrane assembly with platinum catalyst/electrodes bonded to each face of the membrane. Electrical current was applied to the cell by a gold plated stainless steel framework which was held against the electrode faces by the housing. A photograph of the operating cell is shown in figure 15 which shows gas evolution from the oxygen electrode. The gas/liquid space is formed using teflon gaskets, with the liquid inlet at the lower left and gas outlet at the upper left of the photograph. Provisions for recirculation of the liquid may be seen in the ports at the lower right.

This cell was operated for approximately 110 hours under various conditions. While electrical efficiencies appeared to be excellent, i.e., gas evolution at 1.60 volts, several problems became evident upon closer examination of cell operation. From a construction standpoint, the obvious problem of gas phase-liquid phase separation is one that must first be solved. While not an insurmountable problem it represents additional system complexity, whether the separation be by mechanical barriers (i.e., semipermeable membranes) or by induced gravitational fields (i.e., centrifugal separators). In addition, the liquid/electrode interface must be maintained in order for the electrolysis reaction to be sustained. This requires development and testing of wicking techniques for supply liquids to the electrode at appreciable rates over extended periods. Again not a particularly difficult problem but one which adds complexity and weight to an operating system.

Analysis of the effluent gases on the mass spectrometer indicated that carbon dioxide concentrations ran as high as ten percent with a considerably smaller quantity showing up as mass 28 (probably nitrogen). In view of the high contaminant concentrations a gas purification step would be required between the electrolysis cell and the fuel cell. The gas processing step would be required in order to maintain extended fuel cell life characteristics at high power

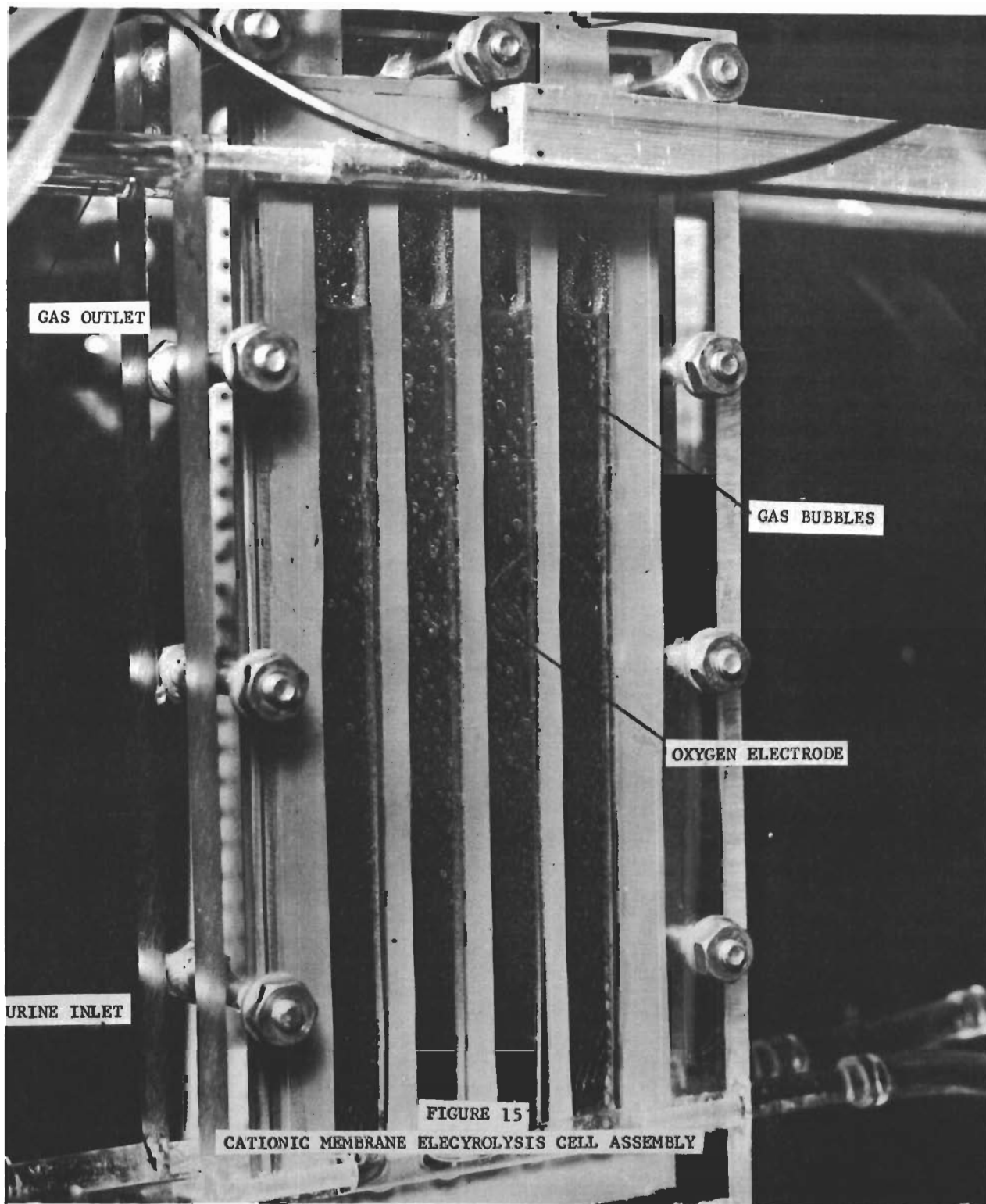

outputs as well as to prevent subsequent recontamination of product water.

Gas purification could be accomplished by zeolite treatment perhaps, in which case the zeolites would require regeneration or replacement at periodic intervals.

For the reasons outlined above an alternate electrolysis cell design was generated. The new design utilizes a double electrode/membrane assembly with a thin liquid electrolyte stream between them. Figure 16 is a photograph showing the components of a double membrane electrolysis test cell prior to assembly. The drawing in figure 17 shows an exploded view of a single test cell assembly. As shown in the drawing, an electrically non-conducting spacer is used to direct the urine-electrolyte solution through a tortuous path between the two membranes. This has the two fold purpose of maintaining good electrolyte continuity between the membranes and preventing concentration gradients from forming in non-circulating pockets of the electrolyte solution.

The cross-sectional sketch in Figure 18 shows a multi-cell electrolysis stack. Note the relative positioning of the spacer ribs adjacent to the collector contact areas to maintain uniform contact pressures in the electrolysis stack. Use of common collectors between cells is an assembly technique frequently used in fuel cell battery systems. The current collectors used in the test cells transfer heat by conduction, larger units have the capability for circulation of liquid coolant as shown in Section V (Figure 24) of this report.

The photographs and diagrams shown here are representative of the test cells used in the ELF Research Program. These cells provide an active membrane area of approximately 12 square inches (2" x 6"). The current collectors are Carpenter 20 steel, gold plated for corrosion protection.

A total of six double membrane electrolysis cells and six standard IEM fuel cells were fabricated and tested as part of this program. The cells and test data are identified in the following manner:

IE - electrolysis cells

FC - fuel cells

Electrolysis cell-fuel cell combinations show the individual identifying code for each cell used, such as IE-1; FC-3.

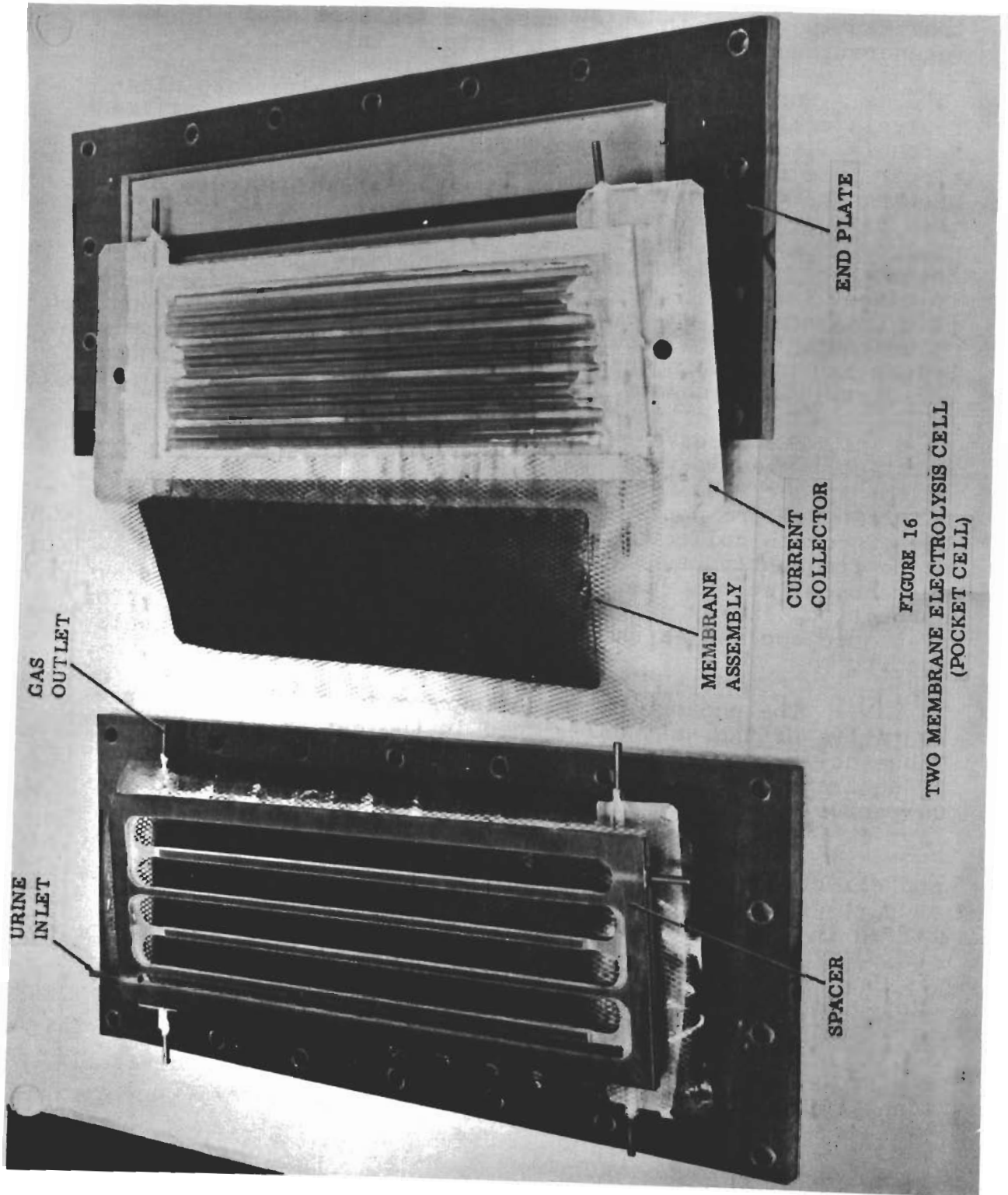

FIGURE 16
TWO MEMBRANE ELECTROLYSIS CELL
(POCKET CELL)

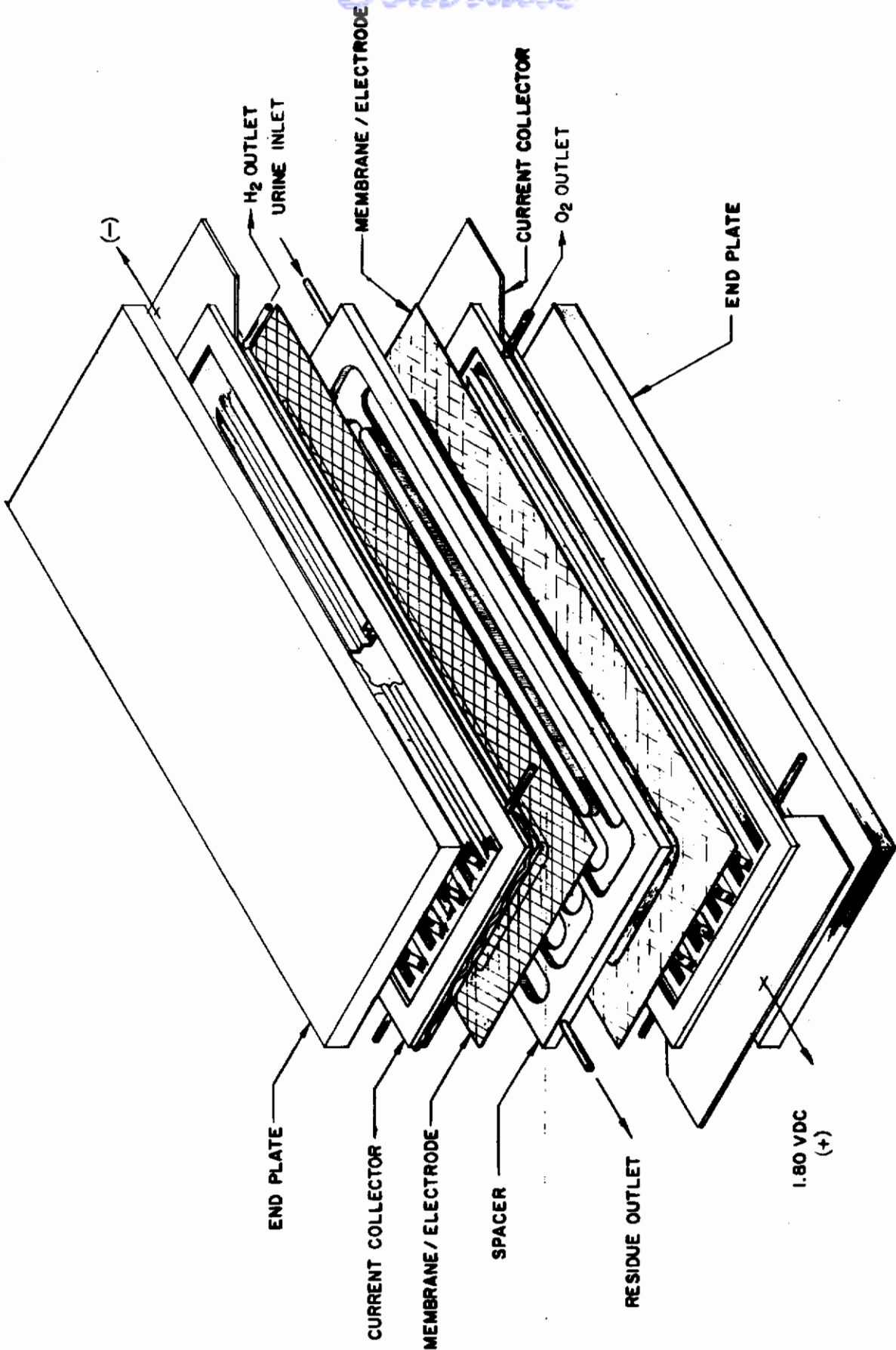

FIGURE 17 DOUBLE MEMBRANE ELECTROLYSIS CELL

43

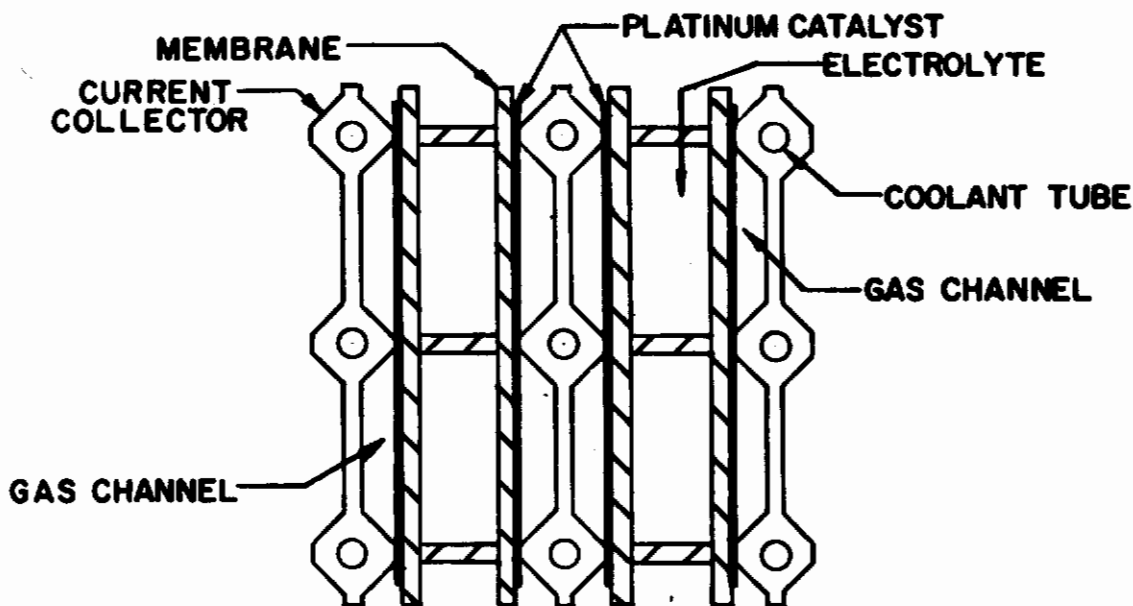

FIGURE 18 CROSS - SECTIONAL VIEW OF TWO CELL STACK

The first series of electrolysis tests were concerned with determining the effects of temperature, pressure, electrolyte concentration, electrolyte circulation, continuous and intermittent operation, and addition of urine to the basic operating parameters of the double membrane cell.

POCKET CELL TESTS

Many extended duration tests were performed with single cell assemblies such as those shown in figure 16. A typical laboratory test set-up for testing of an electrolysis cell and fuel cell is shown in figure 19 showing the physical arrangement of the instrumentation, urine supply, fuel cell gas supplies, etc. Each test series was planned to obtain specific operating data such as effects of temperature, pressure, electrolyte concentration, continuous operation, and intermittent operation.

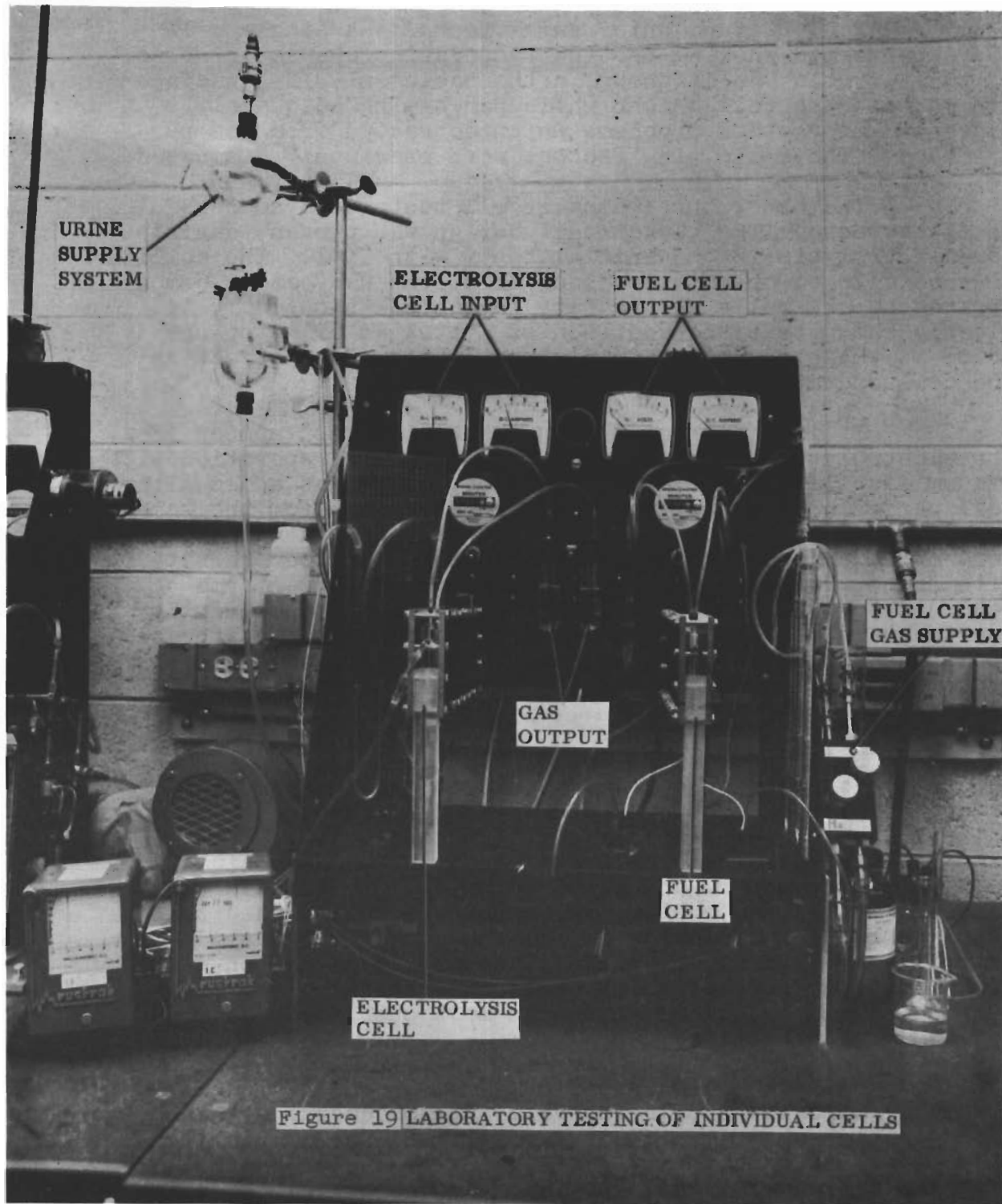

Figure 19 LABORATORY TESTING OF INDIVIDUAL CELLS

Contrails

Table 2 is a brief summation of the single cell tests performed showing pertinent operating characteristics. Of the four test cells shown in the table only IE-3 was a single membrane cell which, while performing adequately, presented many other problems which detracted from its performance. These limiting factors were previously discussed.

The other three single cell tests were successful in all aspects. The pocket cell design was proven feasible for electrolysis in the initial tests with IE-1. The ability of the cells to operate for long durations was easily demonstrated by all cells as the data in table 2 shows. It is clearly shown that the addition of distilled urine or raw urine to the electrolyte supply had little or no affect on the cell operating life.

It is significant to note that in test number IE-2, the electrolyte was changed after 500 hours of operation with vacuum distilled urine. The new electrolyte was added after cell performance had dropped 50 percent, i.e., for the same operating voltage, current densities were approximately 50 percent lower than at the start of testing. After recharging with fresh, 20 percent sulphuric acid the cell performance returned to within 80 percent of the starting power density for the same voltage. This apparent regeneration of the cell would seem to indicate an excessive buildup of salts in the system and/or a depletion of the sulphuric acid in the electrolyte.

Buildup of salts could be anticipated since the electrolysis reaction acts as a concentrator by removing water. Depletion of the sulphuric acid by reaction with salts in the urine is also a distinct possibility. For example, urea-like materials can react to form ammonium sulfate salts, water, and carbon dioxide. By sampling the gases from a closed system, where raw urine was added to 20 percent sulphuric acid, a reaction occurrence was tentatively verified. The analysis showed a high carbon dioxide concentration, part of which could be from dissolved CO_2 , but the major portion of which can most probably be attributed to a chemical reaction.

The gas analyses performed on products of the electrolysis cells show relatively pure products, with the hydrogen side showing highest purity. Because of the likelihood of most contaminant gases being generated on the oxygen side, and the interest in oxygen purity for emergency breathing supplies, extensive analytical coverage was employed to monitor these gases. Table 3 is a summary of analyses run on samples from various test cells.

TABLE 2 TEST SUMMARY

TEST NO.	OPERATING LIFE	TEST OBJECTIVES
IE-1	742 hours	Operating with distilled water to determine effects of electrolyte concentration, and temperature on operating characteristics.
IE-2	861 hours	Makeup was distilled urine. Gas analyses performed. Electrolyte recharged at 500 hours.
IE-3	50 hours	Single membrane design. Gas analysis performed.
IE-4	717 hours	Makeup was raw urine. Gas analysis performed

TABLE 3 ANALYSES OF ELECTROLYSIS CELL GAS OUTPUTS				
	PROBABLE CONSTITUENT			
	H ₂ O	N ₂ /CO	O ₂	CO ₂
TEST NO.	PERCENT BY WEIGHT			
IE-1 (water) (1)	1.9	4.5	95.5	<0.1
IE-2 (dist. urine) (1)	1.9	1.3	95.6	0.9
IE-3 (raw urine) (2)	0.5	9.2	80.5	9.6
IE-4 (urine) (1)	1.4	1.1	97.5	0.3
IE-4,5,6 (raw urine) (3)	*	0.5	99.5	0.1
NOTE: 1. Analysis by Consolidated Electrodynamics Corp., Mass Spectrometer 2. Analysis by Fisher Gas Partitioner 3. Analysis by Perkin-Elmer Corp., Vapor Fractometer * Analysis not performed				

It is evident from the above data that most of the contaminants in urine remain in solution and are not passed on to the fuel cell portion of the system. The relatively high concentration of mass 28 material (N₂/CO) is believed to be nitrogen in most cases and is in fact a nitrogen peak in the analyses run by gas chromatography (test no. IE-4,5,6). The analysis shown for test number IE-4,5,6 is a sample taken from a 3-cell module which was used to recover water for potability tests. The primary concerns for gas purity were two-fold. First, its effect on product water quality, and second, its effect on fuel cell operation. Neither of these effects were limiting. Fuel cells were run in conjunction with the single electrolysis cells and performed as expected for periods up to 40 days. Product water quality likewise was unaffected as will be shown later.

Contrails

During early stages of testing, electrolyte seepage was noticed in the pressure indicating lines. This problem was easily remedied by increasing gas side pressure to compensate for the electrolyte head. Seepage was no longer a problem and gas pressures were maintained at 0.25 inches of mercury or higher (above ambient).

Product Water Quality

The final criteria as to the effectiveness of the ELF system is, of course, the quality of water recovered. To determine the acceptability of this water a series of standard analyses were performed, and the results compared with the Drinking Water Standards set forth by the U.S. Public Health Service (1961).*

Water was collected from a test system composed of a 3-cell electrolysis module and a single fuel cell. Samples were collected and submitted to Betz Laboratories Incorporated, Philadelphia, Pa. The results of the chemical analyses are presented in Table 4. A reproduction of the Betz Laboratory report is contained in Appendix B. These results show the quality of the recovered water to be well within the standards established. Although a complete chemical analysis was not performed due to the limited quantities of water available from the laboratory cells, an extensive laboratory program presently underway is specifically aimed at determining trace contaminants in water generated by fuel cell power supplies and the effects of this water on small animals.

The small animal program, a separate and independently funded contract (Ref. 9), is being performed by the Bio-science Operation at the General Electric Space Technology Center. Preliminary results of this program indicate that fuel cell product water has no immediately visible effects on mice tested. Likewise, preliminary histological examinations revealed no significant abnormalities noted on mice maintained on fuel cell water for a 30 day period.

The program to determine presence of trace chemical contaminants in fuel cell product water is still in progress. However, preliminary analyses have been performed by the Materials and Processes Engineering Operation at the General Electric Space Technology Center. These results are shown in Table 4 along with the limiting values as set forth by the U.S. Public Health Service.

It would appear from these preliminary results that this water would be completely safe for human consumption.

* Journal American Water Works Association, Vol. 53, pp 935-945, 1961

TABLE 4 CHEMICAL ANALYSIS FOR RECOVERED WATER

DETERMINATION	ELF SAMPLE	FUEL CELL WATER (Ref. 9)	U.S.P.H. STANDARDS (1961)	MUNICIPAL WATER *
pH at 25°C	4.2	5.15	10.6	6.6
color (true)	10-15	5	20	2
Ammonia	0.5 ppm	not reported	not reported	not reported
Specific Conductivity mhos	160@18°C	32.2@25°C	500	not reported
Sulfate	0	6 ppm	250 ppm	70
Chloride	18 ppm	7.5 ppm	250 ppm	18
Fluoride	-----**	0.1 ppm	1.0 ppm	not reported
Phenol	-----**	0.015	.001	not reported
Nitrate	0.05	not reported	45 ppm	1.26
Nitrite	0.0	not reported	not reported	0.000
Total Solids:	-----**	not reported	500-1000 ppm	243
Suspended	-----**	1.3	not reported	not reported
Dissolved	-----**	36.3 ppm at 103°C 35.6 ppm at 180°C 20.6 ppm at 600°C	not reported	not reported
Chemical Oxygen Demand	-----**	2.7 ppm	not reported	2.5

* City of Philadelphia Water Department, Monthly Average 1959.

** Dashed lines indicate analysis not performed - insufficient sample

MULTI-CELL TESTING

Several tests were performed with multi-cell assemblies to determine what changes if any would result from joining these cells in a single assembly. None was realized, the 3-cell modules operated as well as the individual cells. The multi-cell modules were used primarily as a gas supply to fuel cells for the purpose of collecting water samples for potability tests. Figure 20 is a photograph of one of the systems; figure 21 is a schematic of that system.

The cells used to recover water from urine were on-stream for a total of 535 to 967 hours before the final sample was completed. The last 240 hours of this time on-stream was continuous operation during the sample collection period. During this period, periodic checks were made of gas flow rates in order to evaluate conversion efficiencies. In general, measured, corrected gas evolution rates were 95 to 105 percent of those rates theoretically determined. Correlation with liquid use rates were fair although evaporation rates from the system had to be estimated to provide this correlation. Without the correction, liquid use rates ran 20 to 25 percent higher than theoretical.

Membranes removed from the system after shutdown showed a slight buildup of solids on the inner membrane surfaces. Figure 22 is a photograph of the membrane before use and after use. The used membrane shown was on-stream for approximately 800 hours. Structurally the membrane was in good condition; therefore, it would appear that degradation of the internal ionic structure due to salt deposits is the prime reason for performance change.

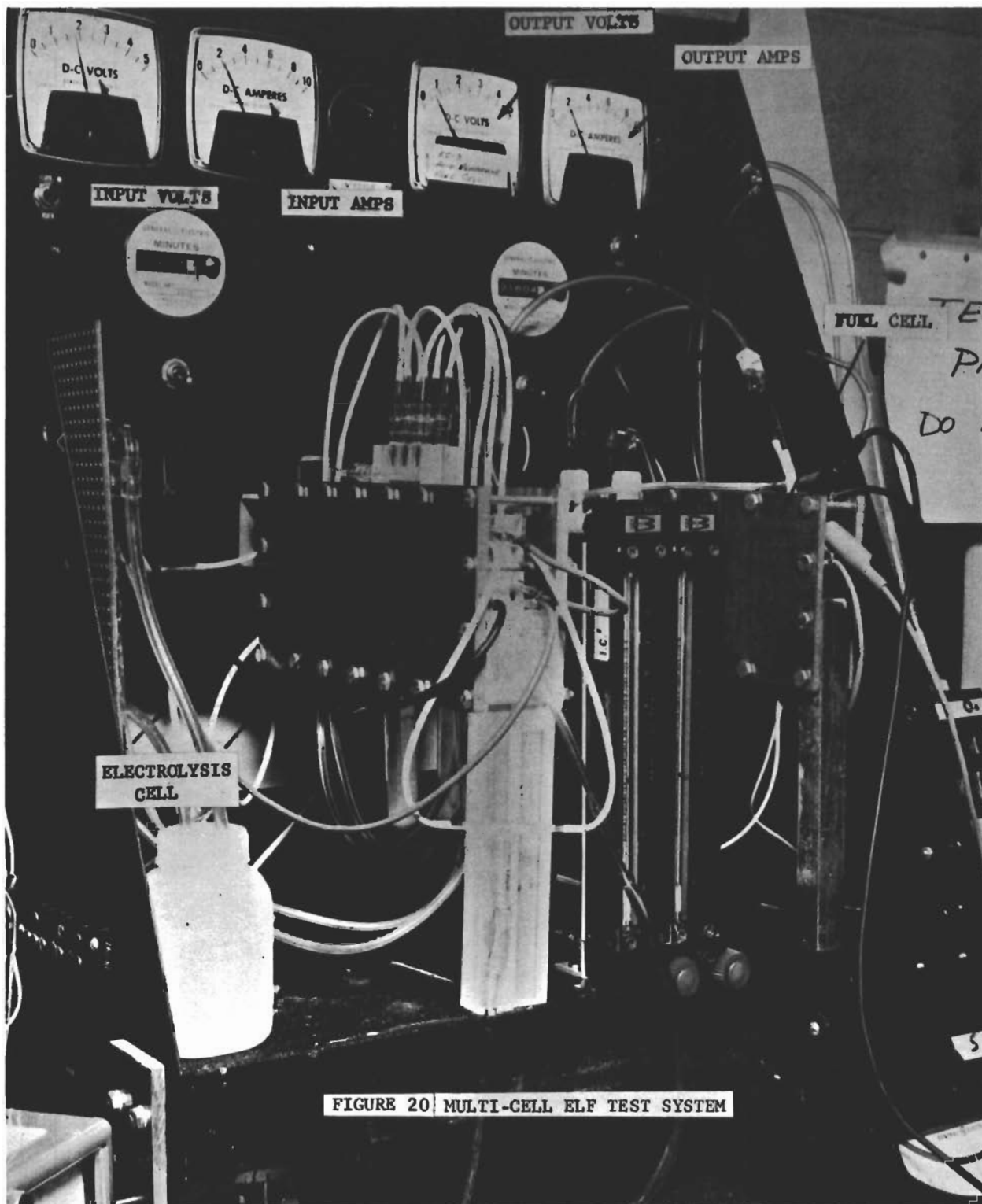

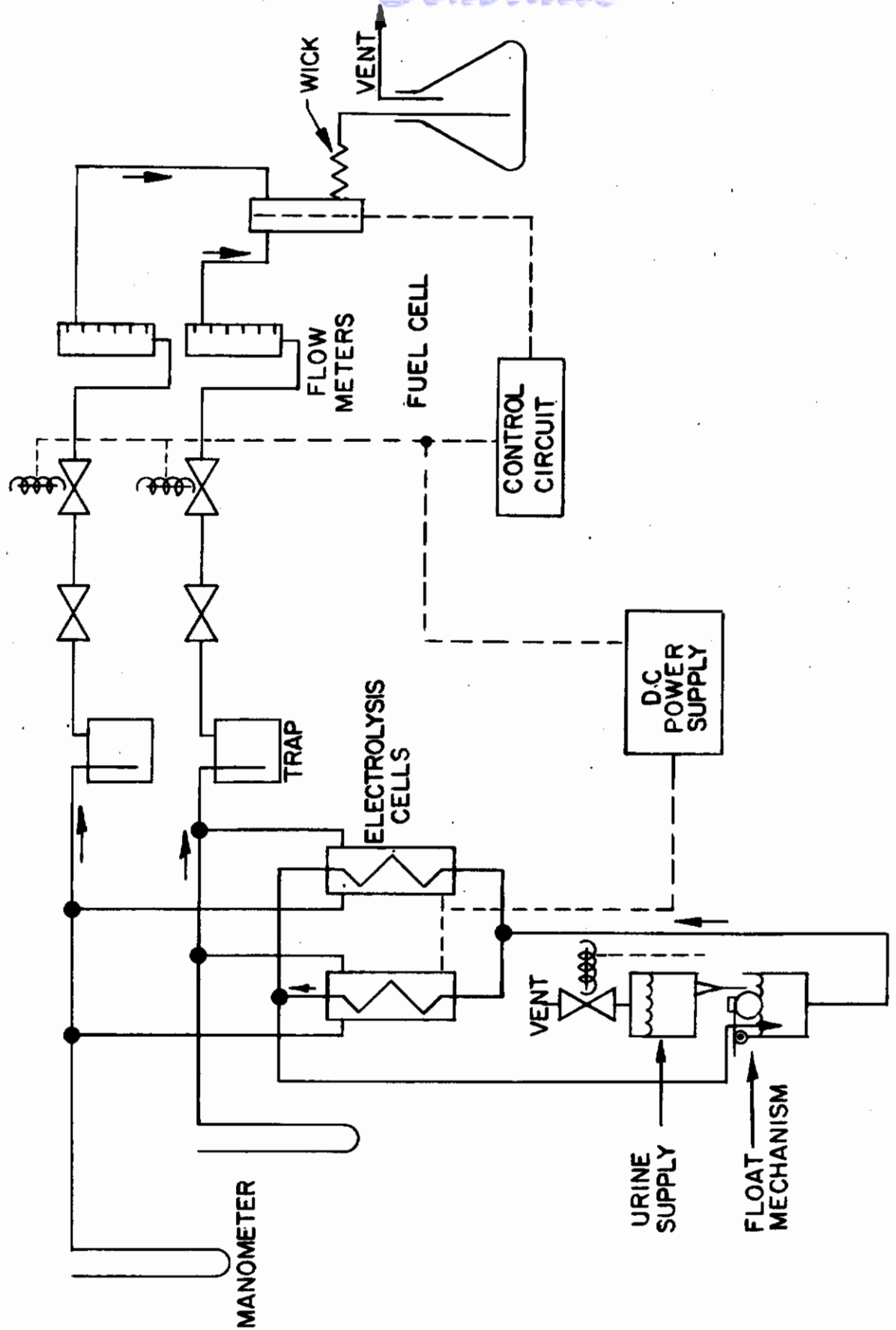

FIGURE 2I ELF TEST SYSTEM SCHEMATIC

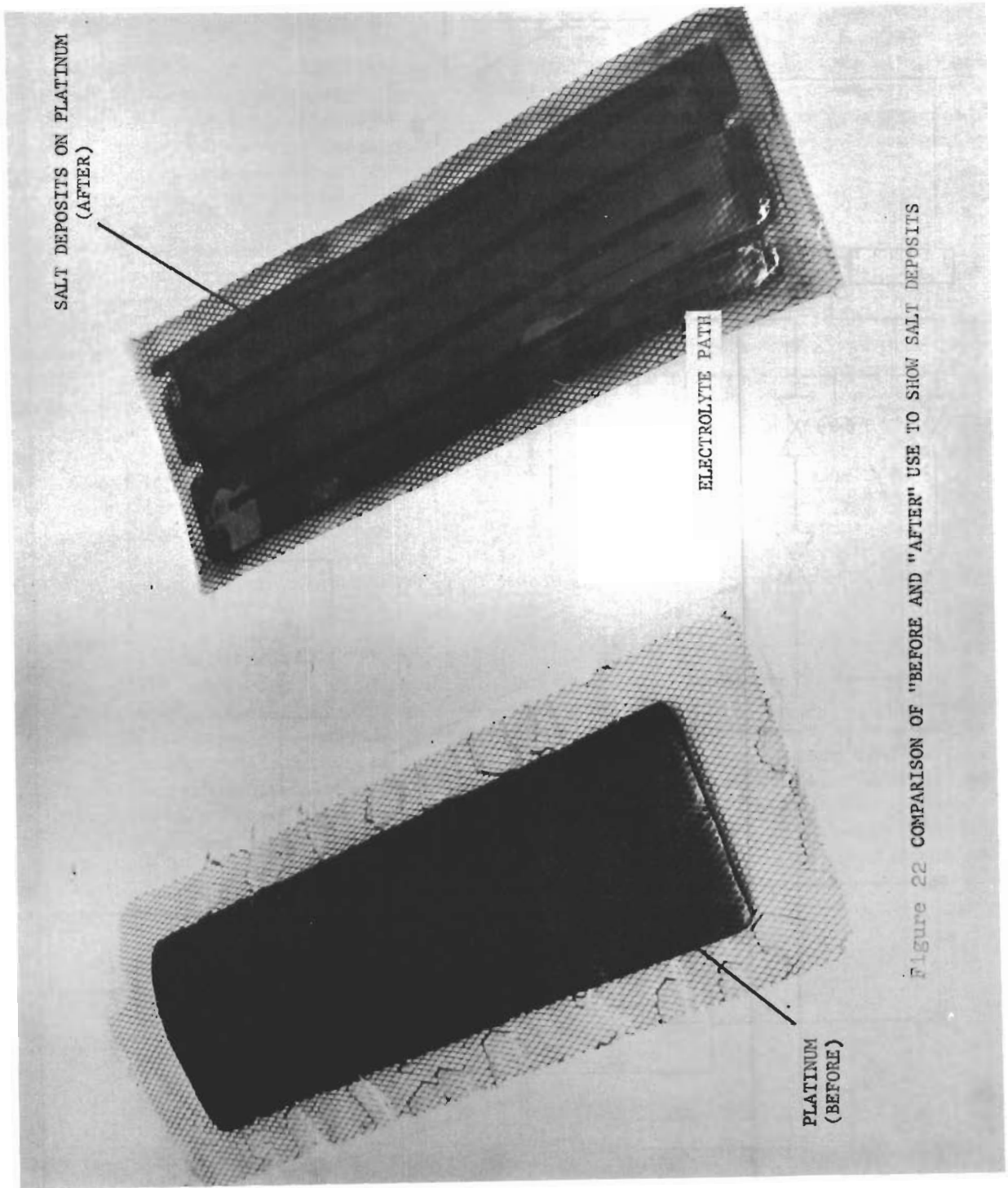

Figure 22 COMPARISON OF "BEFORE AND "AFTER" USE TO SHOW SALT DEPOSITS

SECTION V

EVALUATIONS

Based on the data obtained from research and experimental activities, an advanced ELF system design was synthesized. The advanced ELF System and its predicted performance were compared with the more promising water recovery techniques having the same intended application, i.e., manned spacecraft use.

The major evaluating factors were those pertinent to vehicle system integration such as weight, power, volume, zero gravity function, maintenance, reliability, complexity, development status, etc.

ADVANCED ELF SYSTEM DESCRIPTION

The advanced ELF system for recovery of potable water from urine is basically the same as the experimental unit and has as its primary functional subsystems an electrolysis module and a fuel cell module. In the system schematic shown in figure 23 these modules are shown separately for descriptive purposes. However, because of the physical connections required between the two it would be advantageous to integrate these modules into a single housing.

Electrolysis Module

As shown in the schematic the electrolysis module consists of three stacks of cells, each stack containing 24 cells for a 3-man system. Stacking in this manner permits greater overall reliability since the stacks operate separately and failure or shutdown of one will not affect operation of the units remaining on stream.

Urine is supplied to a pressurized bottle which then adds make-up to the circulating stream as required. Pressure in this bottle is referenced to the oxygen side gas pressure so as to maintain the proper liquid-gas differential. The urine-electrolyte mixture is circulated through the electrolysis units in order to minimize concentration gradients in the cells and also to permit removal of accumulated solids, i.e., precipitated salts, suspended solids, etc., in the filter.

The coolant stream shown is warm fluid from the fuel cell module and is used to maintain the electrolysis module at its operating temperature of 125°F. This coolant is then cooled by the vehicle environmental control system prior to recirculation to the fuel cell module.

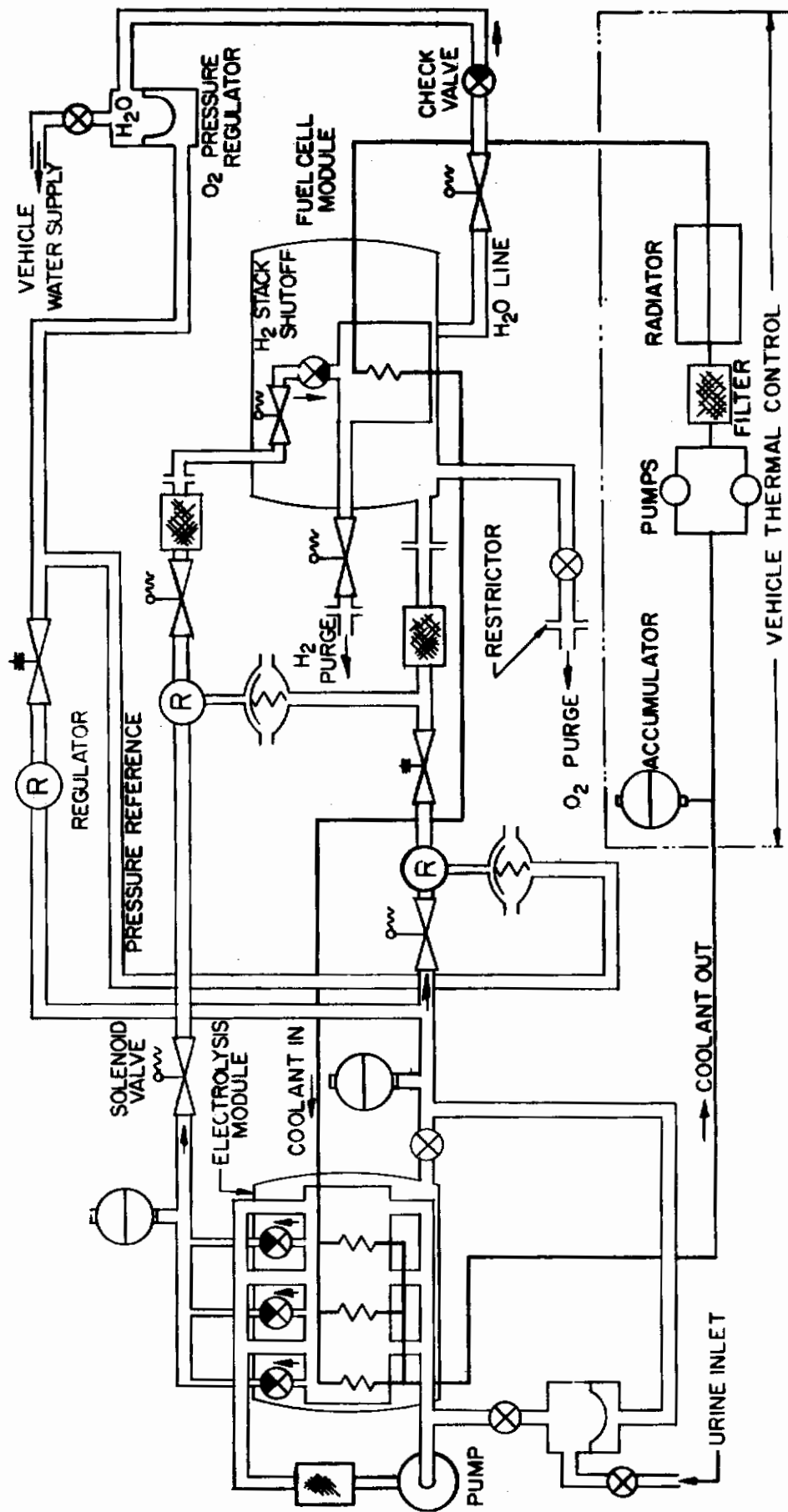

FIGURE 23 ADVANCED ELF SYSTEM SCHEMATIC

Fuel Cell Module

Gases generated are manifolded from each stack, then from the module to the fuel cell stack. In this case the fuel cell stack is made up of 33 cells in a single stack. Manifolding of inlet hydrogen gas can be arranged so as to allow operation of this unit in modular fashion (i.e., 3 to 4 cells per module) if operation in this manner appears necessary. Hydrogen gas is independently fed to each cell while oxygen gas is fed to the void space in the module housing. Oxygen gas pressure is maintained slightly higher than both the ambient pressure and the hydrogen pressure. In this manner, the unit becomes fail safe since a leak to the cabin would be oxygen, similarly a leak in the hydrogen manifolding would let oxygen bleed in. (Because of the small hydrogen gas spaces and the basic modular construction, leakage of oxygen gas into the hydrogen stream will cause only localized damage to the cells manifolded together.)

Cooling of the fuel cell module is by circulation of the coolant fluid through the current collectors as shown in figure 24. This technique provides excellent control of the operating temperatures within the module.

Product water is removed from the fuel cells by a wicking network which transports the water to a separator specifically designed for zero G operation. By maintaining proper pressure differentials in the system liquid water is then transported to a storage tank for subsequent use as required.

Physical Characteristics

The projected system design is based upon present technology and can be fabricated with presently available components. As such the weight, volumes, and dimensions shown in table 5 are realistic and reflect present design capabilities.

TABLE 5 ADVANCED ELF SYSTEM STATISTICS
(3 MAN CAPACITY)

OVERALL WEIGHT	86.1 POUNDS
ENVELOPE DIMENSIONS	12.5 INCH DIAMETER X 38 INCH LONG
VOLUME	2.6 CUBIC FEET
WATER OUTPUT RATE	9.0 POUNDS PER DAY
POWER INPUT	650 WATTS

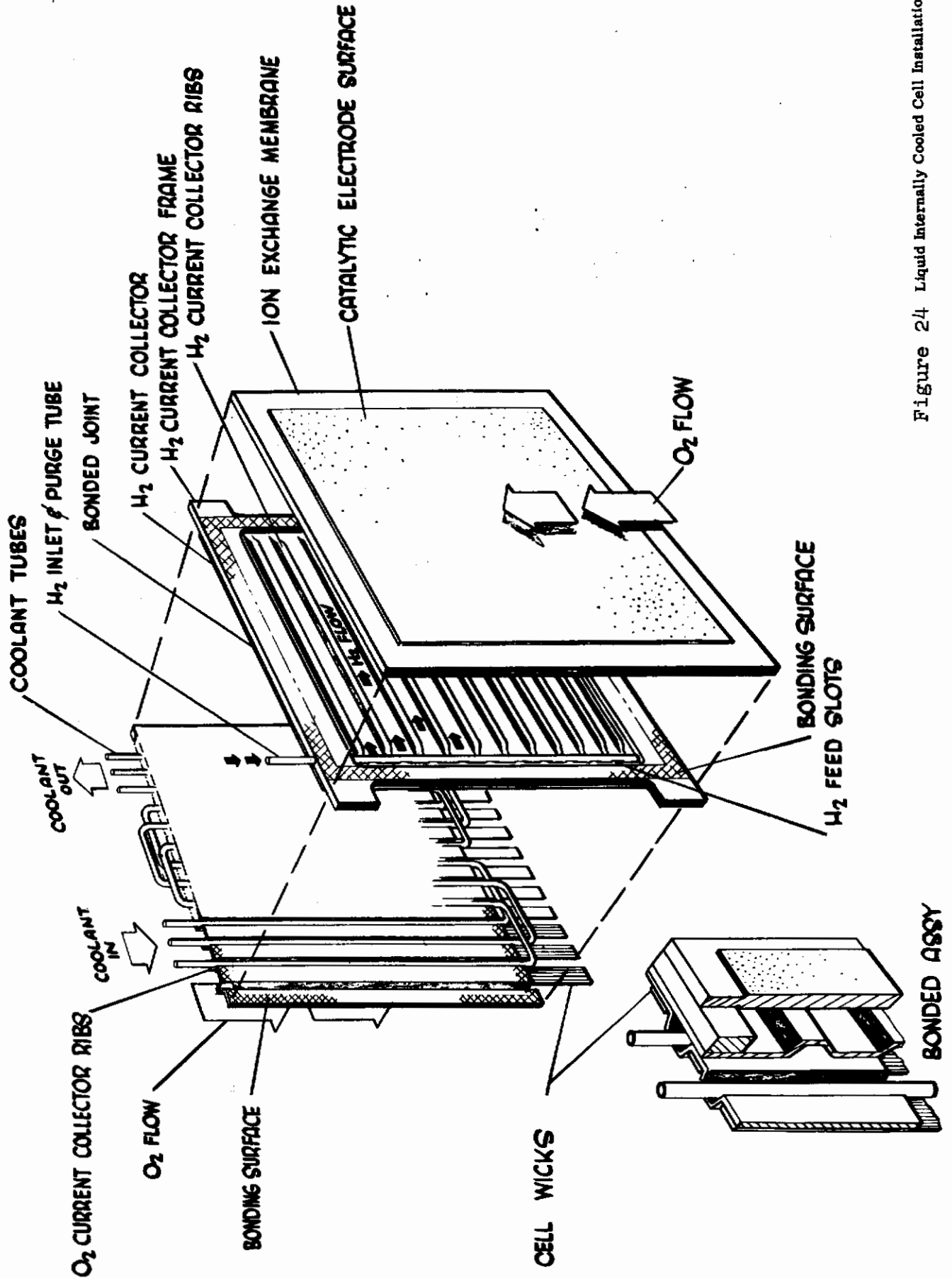

Figure 24 Liquid Internally Cooled Cell Installation

Projecting the system designs to 1965 capabilities as predicted from normal progress to date will decrease the overall system weight by approximately 22 percent and decrease system volume by approximately 40 percent to make the system size about 67 pounds and 1.6 cubic feet.

Since the water recovered requires no additional treatment the weights and volumes presented are independent of mission duration.

TRADEOFF STUDIES

Most of the waste water recovery methods proposed and/or experimented with to date have an additional pre-processing requirement beyond the main recovery process in order to assure acceptable product potability. The supplementary processes may include sterilization of the recovered water, and/or chemical and physical pre- and post-treatments. In addition, water recovery processes have been studied to varying degrees making evaluation of some techniques difficult because of lack of substantiating experimental data. Therefore, the processes chosen for evaluation and comparison with the ELF system are limited to those which have in general been termed feasible, and are undergoing continued development. The prime requisite for evaluating the status of these systems were the data reported in "Water Recovery from Physiological Sources for Space Applications", reference 11.

Other Systems

Where possible, statistics of proposed systems were obtained from original reports covering development and/or testing of these systems. Evaluations by others were consulted wherever possible to obtain correlations and establish the best data available. Based upon these studies, the following systems were determined to be the most feasible and competitive systems presently being considered for space flight applications.

Vacuum Distillation

The Distillation processes as they refer to recovery of water from urine actually represent a combination of evaporation (i.e., separation of a liquid, as a vapor, from a solid) and distillation (i.e., separation of liquids by virtue of their relative volatilities). These processes usually are implemented in one of the following ways; heating the liquid, or lowering the pressure with the subsequent lowering of the boiling point. For systems engaged in water recovery

from urine, vacuum distillation techniques appear to have undergone the most development work to date.

The general results of decreasing operating pressure (hence decreasing temperature) are to suppress decomposition of the organic constituents in urine and thus lessen the subsequent contamination of the recovered distillate, and permit utilization of waste heat sources by reducing heat transfer temperatures. While lower operating temperatures tend to increase chemical purity of the product water, lower temperatures also decrease sterilizing action. It becomes necessary then to compromise and evaluate the effects and potential remedial requirements of various operating conditions.

From laboratory work done by ourselves and by others (references 8, 12, 13), it can be concluded that the distillation process alone will not provide sufficient decontamination to permit direct recovery of potable water. Supplementary treatment to insure potability may take the form of pre-treatment of urine, oxidation of contaminants in the vapor phase, and filtration, ion exchange and sterilization of product water. By using combinations of the aforementioned supplementary processes, potable water has been successfully recovered from urine. Obviously, where additives or tail-end treatments are involved, weight penalties are imposed as a function of crew size and mission duration.

Since phase changes are involved in this processing technique, many schemes have been examined to overcome the problems associated with liquid-vapor separation in a zero gravity environment. These techniques involve various degrees of complexity as well as varied weight and power penalties. For various systems, "total weight" equations have been presented which permit calculation of system weights as a function of crew size and mission duration. From these computations general system comparisons can be made. The distillation systems evaluated are: vapor compression with centrifugal condenser, vacuum distillation with vapor pyrolysis. The weights of these systems are compared in the trade-off curves shown later in this section as figure 27. First, brief descriptions of operating systems will be presented to permit meaningful evaluation of all system parameters.

Vapor Compression

Vapor compression distillation is a method that does not require heat rejection to outer space, since the heat of condensation is recovered and used for vaporization

Contrails

The main feature of the system is the compression of the vapor to raise the condensing temperature to a point where it may be used as a heat source. The vapor compression cycle is graphically represented as follows:

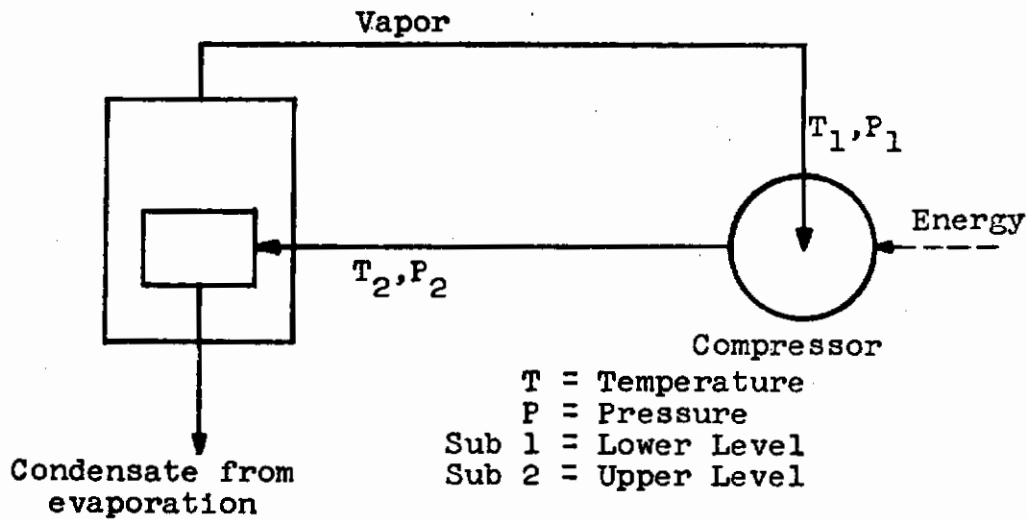

FIGURE 25 Schematic of Vapor Compression System

Electric Boat, and American Machine and Foundry have constructed vapor compression distillation stills for water recovery under zero gravity conditions. Initial units were of a batch type. Design specifications for the AMF unit from reported data are: weight 44.8 pounds (with supplies for 14 batches); size 1.9 cubic feet; power consumption 200 watts; operating cycle 6 hours; recovery rate 10 pounds per cycle; total yield 92 percent. Quality of water recovered from this unit is reported to conform to the U.S. Public Health standards for drinking water, but only following treatment of feed by Hyamine 1622 (for odor and bacteria control) and treatment of recovered water by filtration, mixed bed ion-exchange, and activated charcoal.

Contrails

The line diagram in figure 25 shows the basic flow system for the vapor compression system for operation under normal gravity conditions; however, the evaporator and condenser must separate the liquid phase from vapors and non-condensable gases. This separation has been accomplished by rotation to induce artificial gravity forces.

One technique suggested rotates the evaporator, throwing the waste water against the wall. Suction from the compressor causes the waste water to boil. The vapors are compressed, raising the condensation temperature, and then condensed on the outside of the cooler evaporator vessel. Rotation of the evaporator (or condenser in this application) throws the condensate off onto a collector plate, from which the water is tapped off. Treatment of the recovered water by filtration, ion exchange, etc. renders it potable and ready for use. A system using these principles has been built and is presently undergoing evaluation.

Vapor Pyrolysis

A process technique developed by the General Electric Company uses vacuum distillation of raw urine to produce water vapor (with the usual traces of ammonia and volatile organic compounds). The contaminants are then oxidized with a heated (1200° F) platinum (or platinum-10% rhodium) catalyst. The water vapor is then condensed and collected, while the non-condensable oxidation products are exhausted to space.

The validity of this water recovery concept has been demonstrated in a unit built for the Naval Air Crew Equipment Laboratory in Philadelphia, Pa. Potable water has been successfully recovered by this unit from urine. At the present time, recovery of water by the vacuum distillation/catalytic oxidation technique as demonstrated in the G.E. unit is one of the most advanced pieces of equipment from operational and developmental considerations.

A zero gravity system design has been tentatively formulated with the following system characteristics: weight 30 pounds; power consumption 85 watts; operating cycle 8 hours; recovery rate 1.25 pounds per hour; total yield 92 percent. As previously noted, quality of water recovered is in accordance with U.S. Public Health Standards for drinking water. As an additional testimonial, water recovered from the ACEL unit has been consumed by human subjects without adverse effects.

Freeze Distillation

A distillation technique which eliminates liquid-vapor separation problems in a zero gravity environment, is the process of freezing. Recovery of water from urine by freezing is generally discussed in terms of three specific processes. These are, "Freeze Sublimation", which is based upon freezing of the urine with subsequent sublimation of the solid and condensation of the vapor; "Freeze Crystallization", where urine is partially frozen and the ice formed is washed free of the mother liquor and melted; and "Zone Refining" which is a form of reiterative freezing wherein alternate melting and freezing occurs.

The first of these processes is carried out under vacuum so water may be evaporated directly from the solid state, leaving an ice-free residue. The sublimation step must be carried out below the triple point of water, or at temperatures less than 20° F and absolute pressures lower than 3 mm mercury. Because of these comparatively stringent process requirements, large radiators (up to 8 square feet per man per 12 hour operation), and similarly large volumes (8 cubic feet per man 12 hour operation) are necessary. Experimental data to date indicates that post-treatment of the product is also needed to produce potable water.

Freeze crystallization processes have been effectively utilized in recovery of potable water from sea water; however, similar success has not been forthcoming in recovery of water from urine. Studies to date have indicated that the difficulty has been with preventing ice crystals from trapping mother liquor within the interstices of its crystallites. To overcome this, continuous counter current washing has been suggested. However, it has been stated that this technique does not appear adaptable to space vehicle application because in addition to continuous washing, recovery requires reiterative freezing procedures to obtain significant yields. This seems to indicate that complicated and weighty equipments are necessary. It must be noted that although development efforts have indicated feasibility of the technique for this specific application, detailed design efforts have been minimal. Further efforts may reduce apparent system complexity, hence increasing feasibility. Until such time as this occurs, the freeze crystallization technique for water recovery from urine will not be easily adaptable for space vehicle application. (Reference 13).

Membrane Electrodialysis

One step processes which do not involve phase changes in general are easier to implement. Membrane processes fall into this general category. As a result of extensive development of saline water conversion systems, membrane electrodialysis has received considerable attention.

Membrane electrodialysis is a process in which ions are transferred from one solution through a membrane into another solution by imposition of a direct electrical current. The membrane, usually containing ion-exchange groups, has a positive or a negative fixed electrical charge. As such positively charged anion membranes will selectively pass anions and repel cations while negatively charged cation membranes will pass cations and repel anions.

Electrodialysis units are usually composed of stacks of multimembrane "dilution-concentration cells". Electrodes are placed in the end compartments with cation-permeable and anion-permeable membrane pairs interposed. A D.C. current is applied, causing a migration of ions across the cell, the membranes selectively screening the ions transferred. For example, cations migrating towards the cathode will pass through the cation-permeable membrane. The schematic in figure 26 graphically represents the ion transfer mechanisms demonstrating the basic "dilution-concentration" technique of purification.

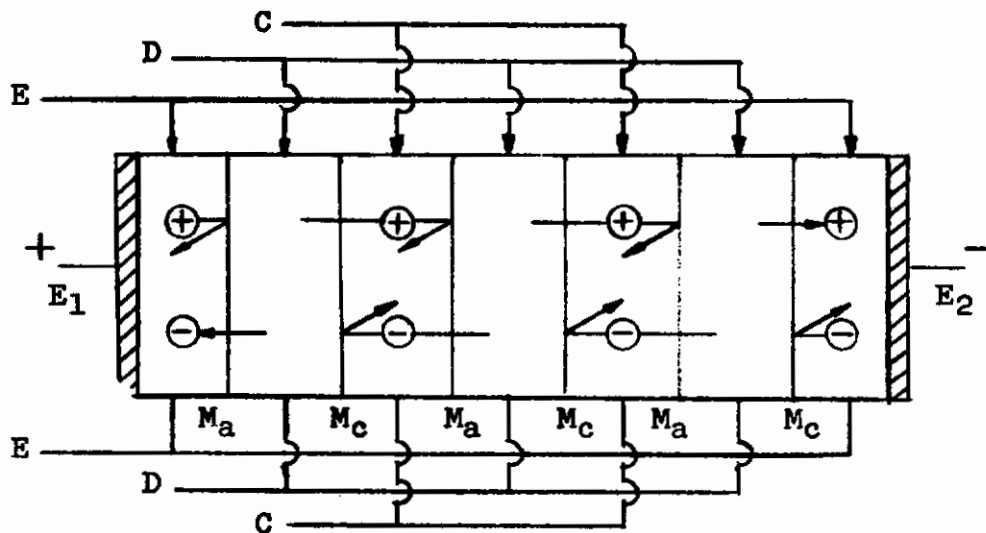

FIGURE 26 SCHEMATIC OF ELECTRODIALYSIS UNIT

Continued

Inlet stream D, representing the raw liquid has both anions and cations removed as it passes through the cell. Conversely, streams C and E become more concentrated in these ions. Stream D then with its ionic content "diluted" is recovered. The other "concentrated" streams must then be stored or rejected as wastes. Circulation of the waste stream can continue until precipitation occurs, at which time effective ion transfer will no longer progress, thereby necessitating removal. Removal of ions is not complete, however, and some ions will always be present in the process stream due to transfer of water across the membranes, the amount being proportional to the applied current.

It is important to note that electro dialysis acts only on salts which are ionized. Therefore, some of the amphoteric constituents and urea will pass through the process unaffected, thereby requiring subsequent treatment of the recovered product to render the water potable. Some electrolysis effects have also been reported where hydrogen, oxygen, and chlorine gas have been generated at the electrodes.

Sizing of the electro dialyzer is a function of ion concentrations, solution flow rates, and current densities (as related by Faraday's Laws). Performance characteristics and system designs can be tentatively determined for these systems from data reported by Ionics, Inc. (Reference 14). For low process flow rates and moderately concentrated solutions it is reportedly possible to obtain 75 percent demineralization per pass.

To accomplish the degree of decontamination required, it would appear that three stages are necessary. Presently reported yields are approximately 80 percent, thereby posing a disposal problem for the remaining 2.0 pounds per day of waste solution.

Tail-end treatment of product water may be expected to require approximately 0.25 pounds per day of activated charcoal. Pre-treatment of urine to minimize tail-end absorption loads will impose an additional weight penalty of approximately 0.1 pounds per day. The estimated weight of the electro dialysis unit will be approximately 24 pounds, with the additional weight penalty of 0.35 pounds per day for supplementary treatment. While power requirements are estimated to be low for a unit capacity of 10 pounds urine per day (approximately 400 watt hours per day), successful implementation of a unit of this capacity has not yet been efficiently demonstrated.

Contrails

It should be noted here, however, that this technique is still in the early investigative stages. As such, design improvements resulting from these investigations could do much to increase efficiencies and recovery rates.

Trade-off Analyses

System comparisons for space applications are initially evaluated on the basis of the characteristics of weight, volume, and power consumption. These represent the tangible factors involved in system selection. However, such factors as system complexity, flexibility, inherent reliability, etc., represent the less tangible factors which in some cases are at least equally as important as the usual weight, volume, power criteria.

In this analysis, in addition to presenting the weight and volume comparisons, an attempt is made to present a few of the other vital characteristics which must be considered. Table 6 is a summary of the vital statistics of the systems discussed. Where specific statistics were not available, engineering estimates were made and as such may deviate slightly from estimates reported by others. These estimates, however, are based upon sound engineering practices and as such should be representative.

TABLE 6			
SUMMARY OF WATER PROCESSING SYSTEMS			
PROCESS DESCRIPTION	WEIGHT (LBS.)	POWER (WATTS)	VOLUME (CUBIC FEET)
ELF	67	650	1.6
Vapor Compression	44.8	200	1.9
Vacuum Pyrolysis	30	85	1.7
Centrifugal Evaporator & Refrigerated Condenser	53.9	25	2.5
Electrodialysis	24	17	0.5
Ultrafiltration	50	~ 50	1.3
Freeze Distillation	45	0	16.2

Contrails

The system characteristics shown in the table are for units with the capacity to handle the urine outputs of 3 men (approximately 10.0 pounds per day). The weight and volume estimates shown are for the basic system hardware and do not reflect variable weight penalties for pre- and/or post-treatment, makeup water, or electrical power. Weight penalties for space power systems are estimated to be 125 to 470 pounds per kilowatt for solar photovoltaic (power penalties are strongly dependent upon mission profiles). Other variable weights are reflected in the tradeoff curves figure 25, where system weights are shown as a function of mission duration.

The curves shown in figure 27 reflect the weights of each system with sufficient capacity to process 10.0 pounds of urine per day (3 man output). To put comparisons on an equal product rate basis, those systems having lower recovery efficiencies than the ELF system (which approaches 98 percent of the water content of urine), had the equivalent weight of water added to the original system weights. Weights of supplementary additives are also reflected in these curves.

An intangible aspect of the system comparisons that is not reflected in either the table or the trade-off curves, is the relative reliability of these systems. In general, the ELF system, along with other membrane type systems, shows a high degree of reliability due to the very nature of their operation. Moving parts are not an essential part of the system thereby eliminating an important reliability problem.

Results

Results of the weight comparisons show the ELF system to be competitive with all but the vapor pyrolysis system after 26 days. Considering missions of 14 days or longer, it appears that from a standpoint of weight, the ELF system incurs an additional weight penalty of from 1 - 11 pounds when compared with the vapor compression system or the centrifugal evaporator system.

However, examining these systems for other characteristics, perhaps less tangible in nature but equally as important, the difference in weight may become less important. Both the vapor compression and centrifugal evaporator systems utilize an induced gravity to accomplish phase separation. The use of a centrifugal evaporator in both systems adds mechanical complexity. The vapor compression system also requires a compressor to raise the

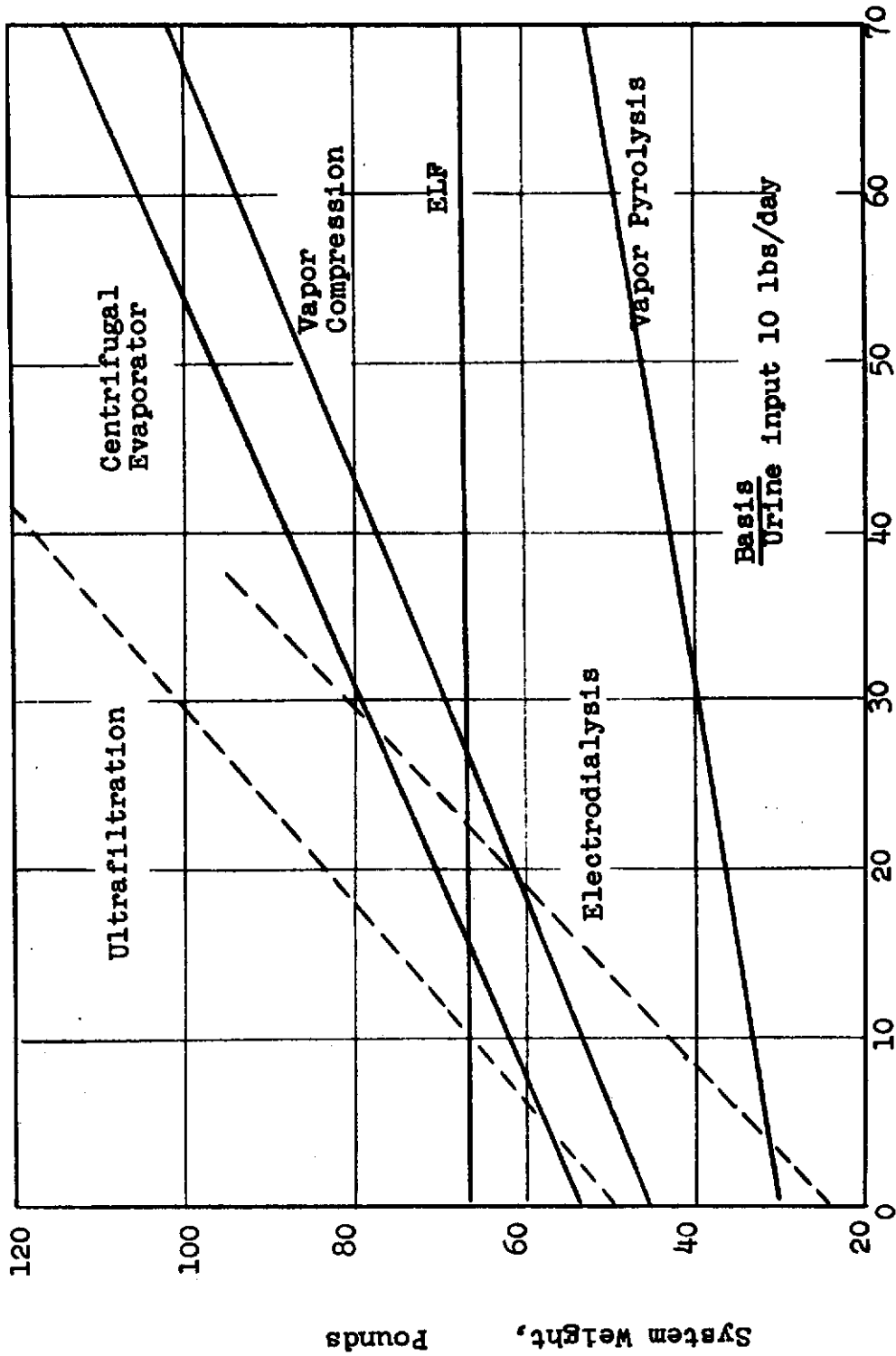

Figure 27 Weight Comparisons for Water Recovery Systems

Contrails

condenser temperature and permit use of waste heat. In contrast to these systems which rely on mechanical moving parts, the ELF system operates quietly and more efficiently without the requirements for moving parts. ELF system operation is gravity independent and inherently more reliable because its operation is not contingent upon the reliability of various rotating devices.

In addition, the laboratory model of the ELF system has demonstrated its ability to operate continuously for periods in excess of 600 hours without serious degradation in performance. Distillation systems, in general, operate on a batch basis with periodic cleanout of the evaporator vessel required. Thus, it is evident that the continuous, automatic operation of the ELF system will require less maintenance time. Removal of accumulated solids in the ELF System may be readily accomplished without requiring shutdown of the unit.

In addition to routine cleanout of most evaporative systems, pre-treatment of urine and post-treatment of the recovered product may require periodic monitoring. The ELF system has clearly demonstrated that the product water is potable as recovered. As mission durations increase, supplementary treatment requirements pose an ever increasing logistics problem, a problem not shared by the ELF system. Replacement membranes for the complete ELF system will involve approximately one pound of storage weight. It is not expected that membrane replacement will be required for periods less than 60 days.

System flexibility which permits use of the ELF unit as a gas generating device adds to the advantages already noted. The electrolyzer in the system can be used to furnish oxygen gas at pressures up to 100 psia (if so designed) where operation in this manner is desired. Obviously the quantity of water recovered is then lowered as a result of the gas bypass to another system. However, the option to perform in this manner is always present.

On the basis of these factors it would appear that the ELF Water Recovery System warrants further considerations for use in manned missions in excess of 14 days.

CONCLUSIONS AND RECOMMENDATIONS

The significant results of the ELF Research program just completed can best be summed up by the conclusions which became evident upon evaluation of these results. In general, the conclusions arrived at can be categorized as those being significant from the systems standpoint, and those being primarily significant on the subsystem or component level. Obviously, all of the results have an impact on the ELF System design, but the significance of each can sometimes be better expressed as an entity in itself.

CONCLUSIONS

POTABLE WATER RECOVERED FROM RAW URINE

Chemical and bacteriological analyses of the product water recovered from ELF test systems were well within the United States Public Health Standards for all points tested. As a further substantiating factor, the preliminary results of a small animal toxicity program (performed under an independently funded contract) have indicated that consumption of fuel cell generated water is not harmful.

RECOVERY OF WATER APPROACHES 98 PERCENT OF THAT AVAILABLE IN URINE

The recovery of water from urine must be performed efficiently for use in spacecraft. The inherent conversion efficiency of electrolysis cells was substantiated by the experimentally determined material balances of the ELF test system, where up to 98 percent of the water found in urine was electrolyzed and made available for recovery. Chemical efficiencies of fuel cells approach 100 percent thereby giving an overall ELF System recovery rate of approximately 98 percent.

ELF SYSTEM EXHIBITS LONG LIFE

The operation of test cells for periods up to 900 hours clearly shows the stability of electrodes, catalysts, and membranes. Continuous (240 hours) and intermittent operational modes were clearly demonstrated and indicated no start-up or shut-down problems. The inherent maintenance free reliability of a system with no moving parts was evident in the ELF test components.

TRADE-OFF SHOWS ELF SYSTEM COMPETITIVE

The trade-off analyses performed on the projected ELF system design showed the system to be clearly competitive (on weight basis) with other water recovery systems presently being developed for space application. The ELF System was shown lighter than most systems (GE Vapor Pyrolysis System is lighter) for mission durations in excess of 26 days. Certainly a promising system for space station or "far space" probes. The projected designs were those for the near future (1965) and as such represent essentially "state-of-the-art" hardware.

GRAVITY INDEPENDENT OPERATION

While zero gravity experiments were not performed on the ELF System, operation of the basic components was tested in zero gravity experiments with regenerative fuel cells. The successful completion of these tests provide substantiating proof of the gravity independent nature of the electrolysis cell-fuel cell design. Phase separations in the electrolysis modules are naturally implemented by the double membrane pocket cell construction. The fuel cell water recovery and transport subsystem design has been tested at various inclinations (including upside down) thereby demonstrating its gravity independent operation.

SYSTEM EXHIBITS HIGH DEGREE OF FLEXIBILITY

In the design analyses, use of the ELF System was contemplated as possible sources of breathing oxygen, and hydrogen for carbon dioxide reduction. Experimental data substantiated the feasibility of this use when oxygen and hydrogen gas purity were shown to be extremely high even from the electrolysis of urine. As an emergency oxygen supply the ELF system can be used to supply the system redundancy required for safety, without the necessity of being maintained in a continuous non-operating stand-by condition.

These are the conclusions reached from an evaluation of the overall program showing briefly the ultimate effects at the system level.

There are several conclusions, which, although very much a factor in system design, are much more evident when considered on a component or subsystem level. The order in which these are now presented is not meant to convey any degree of importance since each has an equally strong impact on its own merits.

Contrails

MEMBRANE ELECTROLYSIS CELLS EXHIBIT GOOD ELECTRICAL EFFICIENCIES

The operation of ion exchange membrane electrolysis cells at potentials less than 2.0 volts for extended periods of time point up several important factors. The choice of double membrane pocket cell construction has increased cell resistances slightly due to the liquid electrolyte phase; however, this design has apparently decreased catalyst poisoning problems. The apparent absence of excessive catalyst poisoning is probably the most significant factor permitting electrolysis cell operation for extended periods. In the pocket cell construction the catalyst does not come into direct contact with raw urine since the liquid must first permeate the membrane before reaching the catalyst.

The significance of the low operating voltage can best be shown by a comparison with commercial electrolysis systems. Figure 28 is a comparison of data obtained with ELF laboratory systems and data reported for commercial systems (References 15 and 16). The band shown for the ELF system represents data from all double membrane cells tested for durations in excess of 100 hours. Note also the theoretical and minimum voltages shown on the curves for reference purposes indicating the somewhat limited degree of performance improvement which might still be gained through system development efforts.

HIGH PURITY GASES GENERATED

The production of comparatively high quality oxygen gas generated by the electrolysis of urine has raised the possibility that the ELF system could provide an emergency breathing oxygen capability, or an electrolysis module alone could be used as a source of oxygen make-up or supply. The characteristics of electrolysis modules generating oxygen from urine are briefly summarized in Table 7.

The module weights shown are sized to handle only the liquid volumes required to generate the oxygen weights shown. The liquid volumes can be readily supplied by collection of urine from the vehicle or station waste management system. The hydrogen generated along with the oxygen may be used for example, in a carbon dioxide reduction system. It would seem that the generation of oxygen by electrolysis may well be applicable to space station or deep space probe systems.

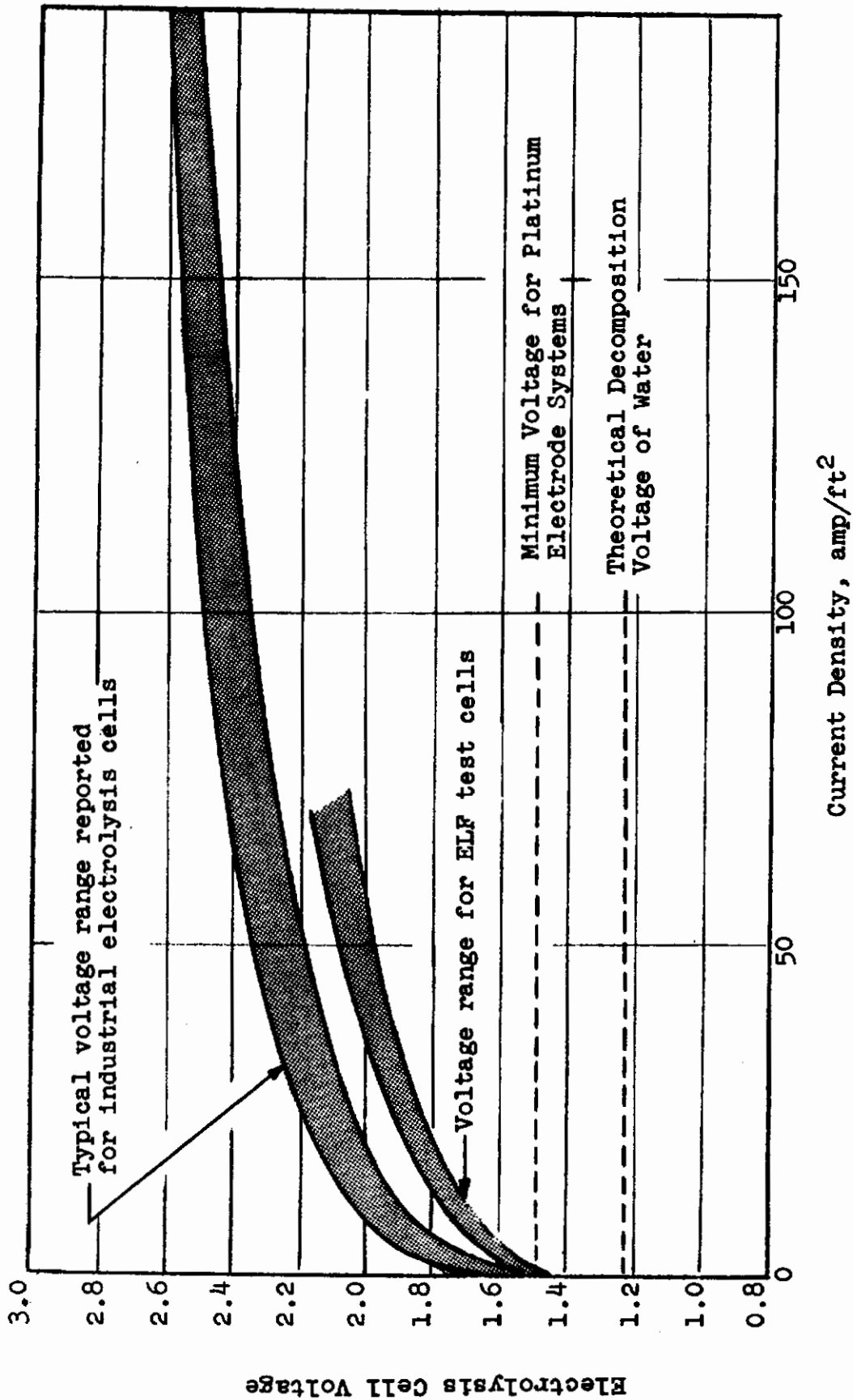

Figure 28 Comparison of Cell Voltages Obtained in Laboratory Tests With Reported Values for Industrial Cells

TABLE 7			
ELECTROLYTIC OXYGEN GENERATOR			
NUMBER OF MEN	WEIGHT OF OXYGEN (POUNDS)	MODULE WEIGHT (POUNDS)	POWER REQUIRED (WATTS)
1	2.0	20	269
2	4.0	31	536
3	6.0	43	805
4	8.0	55	1074
5	10.0	67	1341
6	12.0	79	1610

RECOMMENDATIONS

Results of the ELF Research Program have clearly demonstrated the success of the ELF technique for recovering potable water from urine. That this technique is directly applicable to manned space flights was indicated by the system tradeoffs performed, and the apparent versatility and multiple function capabilities of the system add to the desirability of integrating the ELF System with the overall man-vehicle complex. On this basis, continued development of the ELF System should be programmed and eventually include design, fabrication, and test of a flight prototype unit.

In line with a development program of this kind, the following items warrant specific consideration.

Detailed design and development of the electrolysis module to optimize size, weight, and electrical efficiency.

Determine automatic technique for monitoring effluent water streams to determine acceptability on a flight prototype system.

Spacecraft vehicle analyses to assure complete functional integration of the ELF System with the overall man-vehicle complex.

Contrails

Determine ability of ELF System to function on water from other sources, (e.g., feces, wash water, and respiration).

Since a highly successful (or reliable) water recovery unit is not presently available for space applications, it appears imperative that ELF System development continue. The initial success of laboratory systems indicate strongly that the ELF Water Recovery System will be a strong contender in future manned space missions.

Contracts

SECTION VII REFERENCES

- (1) Starkey, G. E., "Fuel Cells for Astronautic Application," Paper presented at ARS Space Power Systems Conference, Santa Monica, California, September 27-30, 1960.
- (2) Belasco, N., Fogal, G. L., Leisenring, J., Water Purification, U.S. Patent Application 141494, Application date September 28, 1961.
- (3) Douglas, D. L., "Status of Ion Exchange Membrane Fuel Cells", presented at the AIEE 1962 Pacific Energy Conversion Conference, August 12-16, 1962, San Francisco, California.
- (4) Grubb, W. T., Hodgdon, R. B., Neidrach, L. W., "Ion Exchange Membranes in Fuel Cells," presented at the 141st Annual Meeting of the American Chemical Society, March 27, 1962.
- (5) Blackmer, R. H., Phillips, G. A., "Ion Exchange Membrane Fuel Cell for Space Vehicle Electric Power," presented at the SAE National Aerospace Engineering and Manufacturing Meeting, October 9-13, 1961, Los Angeles, California.
- (6) Glasstone, Textbook of Physical Chemistry, Second Edition, D. Van Nostrand Company, Inc., pp. 1014-1023, October 1946.
- (7) Chemical Engineers' Handbook, Edited by John H. Perry, 3rd Edition, McGraw-Hill Book Company, New York, N. Y. Page 1782, 1950.
- (8) Konikoff, J. J., Bengson, M. H., "Recovery of Potable Water from Man's Metabolic Wastes," Technical Information Series R6OSD341, General Electric Company, Missile and Space Division, Philadelphia, Pa., 1960.
- (9) Ekberg, D., Silver, E., "Preliminary Report on Fuel Cell Product Water Potability," General Electric Company, Missile and Space Division, Philadelphia, Pa., October, 1962.
- (10) McKinley, G., Wanger, H., Hales, W., "Chemical Analysis of Fuel Cell Product Water," Program Information Release, No 9383-38, General Electric Company, Missile and Space Division, Philadelphia, Pa., November 27, 1962.

Contrails
REFERENCES (Continued)

- (11) Slonim, A. R., Hallam, A. P., Jensen, D. H., Kammermeyer, K., Water Recovery From Physiological Sources for Space Applications, Aerospace Medical Division Technical Report MRL-TDR-62-75, Wright-Patterson Air Force Base, Ohio, July 1962
- (12) Zeff, J. D., Bambanek, R. A., Development of a Unit for Recovery of Water and Disposal or Storage of Solids from Human Wastes. Part I - The Study Phase, Wright-Patterson Air Force Base, Ohio, November 1959.
- (13) Wallman, H., and Barnett, S. M., Water Recovery Systems (Multi-Variable), Wright Air Development Division Technical Report 60-243, Wright-Patterson Air Force Base, Ohio, March 1960.
- (14) W. L. Badger Associates, Inc., Study of Processes for the Production of Potable Water From Aqueous Wastes Developed in a Shelter, Prepared for the Office of Civil Defense, Department of Defense, Contract No. OCD-OS-62-120, Research Project 1413, October 1962.
- (15) Mantell, C. L., Industrial Electrochemistry, 3rd Edition, McGraw-Hill Book Co., Inc., page 456, 1950.
- (16) Clifford, J., Gates, J., McCallum, J. and Faust, C., Research on the Electrolysis of Water Under Weightless Conditions, Aerospace Medical Division Technical Documentary Report MRL-TDR-62-44, Wright-Patterson Air Force Base, Ohio, May 1962.
- (17) Hall, J. F., Original ELF Feasibility Test Data, Autogram No. D329, General Electric Company, Missile and Space Division, Philadelphia, Pa., March 1963.

Contrails

Appendices

APPENDIX I

Results of water analysis from Initial Feasibility Testing (Ref. 17).

(Performed by Betz Laboratories, Inc., Philadelphia 24, Pennsylvania)

Contrails

rec'd.
sample dated 8-22-60

SAMPLING POINT	Sample "A" Distilled Urine 7-27	Sample "B" Distilled Urine Filtered	Sample "E" Distilled Water 8-17	Sample "F" Distilled Urine Control 8-19	Sample "D" Jan. 9, 1961 Fuel Cell Purifier
Ammonia as N, ppm	25	12.5	0.03	10	15
Carbon Dioxide as CO ₂ , ppm	24	0	7	0	0
Total Hardness as CaCO ₃ , ppm	3	3	**	4	0
"P" Alkalinity as CaCO ₃ , ppm	0	14	0	0	12,360
"M.O." Alkalinity as CaCO ₃ , ppm	0	84	4	44	15,300
Sulfate as SO ₄ , ppm	**	**	**	**	371*
Chloride as Cl, ppm	16	3.0	0.5	18	700
pH (Elect.)	2.10	8.80	5.00	7.30	12.90
Spec. Conductance micromhos 18C	260	160	7.5	180	33,000
Free Mineral Acid	446	- - - NOT REPORTED			- - -
Nitrate as NO ₃ , ppm	0.08	0.08	0.03	0.02	0.075
Color Units	25	15	7	15	10
Nitrite as NaNO ₂ , ppm	0.00	0.19	0.00	0.00	NOT REPORTED
Odor	Weak Urine Odor	None	None	Weak Putrid Urine Odor	very rank & putrid
Total Solids, ppm	80	68	0	104	29,120
Phenol, ppm	0.14	0.18	0	0.17	2.0
Potassium as K, ppm.		- - - - NOT REPORTED			- 6000
** Insufficient Sample * Interference					

APPENDIX II

Results of Water Analysis from Laboratory Experimental Systems.

(Performed by Betz Laboratories, Inc., Philadelphia 24, Pennsylvania)

Contrails

sample dated: 11-5-62

SAMPLING POINT	FC-6 O ₂ side				
Ammonia * as N, ppm	0.50				
Carbon Dioxide as CO ₂ , ppm					
Total Hardness as CaCO ₃ , ppm	36				
Calcium as CaCO ₃ , ppm	28				
Magnesium as CaCO ₃ , ppm	8				
Phenolphthalein Alkalinity as CaCO ₃ , ppm	0				
Methyl Orange Alkalinity as CaCO ₃ , ppm	0				
Sulfate as SO ₄ , ppm	0				
Chloride as Cl, ppm	18				
Silica as SiO ₂ , ppm					
Total Phosphate as PO ₄ , ppm					
Ortho Phosphate as PO ₄ , ppm					
pH	4.2				
Specific Conductance, micromhos 18C	160				
Specific Conductance, micromhos 18C (corrected)					
Nitrate as N, ppm	0.05				
Nitrite Nitrogen as N, ppm	0.0				
Free Mineral Acid	4.5				
Color (true) *	10-15				
* Note: Analysis performed by Adv'd Life Support Engrg. Personnel					

Contrails

date | November 19, 1962

sample marked | Life Support Engr. Elf. Program - Water Sample for Bacteria
Potability Analysis
date sample obtained | November 13, 1962

Date sample received: November 13, 1962

Date sample analyzed: November 13, 1962

	Results	
	<u>Period of Incubation</u>	
	24 hrs.	48 hrs.
Total Number of Bacteria per ml on Agar	0	
Presumptive Test (Streptococci)		
<u>Volume of Sample</u>		
10.0 ml	0/5	0/5
1.0 ml		0/5
0.1 ml		0/5

REMARKS:

This sample as tested conforms with the bacteriological requirements of the U. S. Public Health Service Drinking Water Standards.

Contrails

date | November 19, 1962

sample marked | Life Support Eng. Elf. Program - Water Sample for Bacteria
date sample obtained | November 13, 1962 Potability Analysis

Date sample received: November 13, 1962
Date sample analyzed: November 13, 1962

	Results	
	<u>Period of Incubation</u>	
	24 hrs.	48 hrs.
Total Number of Bacteria per ml on Agar	0	
Presumptive Test (Coliform Group)		
<u>Volume of Sample</u>		
10.0 ml	0/5	0/5
1.0 ml		0/5
0.1 ml		0/5
Most Probable Number (M.P.N.)		0

REMARKS:

The presumptive test for members of the Coliform Group was negative in all of the five 10 ml portions of the sample.

This sample as tested conforms with the bacteriological requirements of the U. S. Public Health Service Drinking Water Standards.