

**A STUDY OF CONVENTIONAL AIRPLANE  
HANDLING QUALITIES REQUIREMENTS  
PART I. ROLL HANDLING QUALITIES**

*I. L. ASHKENAS*

**Distribution of this document is unlimited**

# Contrails

## FOREWORD

This report represents a portion of the effort devoted under Contract No. AF 33(657)-10407 to the codification of conventional airplane handling qualities requirements. The work was performed by Systems Technology, Inc., Hawthorne, California, under Project No. 8219, Task No. 821905, sponsored by Air Force Flight Dynamics Laboratory of the Research and Technology Division. The research period was from January 1963 through May 1965, and the manuscript was released by the author in May 1965 as STI-TR-133-2. The RTD project engineers have been R. J. Wasicko, P. E. Pietrzak, and J. R. Pruner.

It was originally expected that the efforts reported here would be incorporated into a fairly definitive design guide. To this end, a draft version of the report dated 18 June 1964 was circulated to various specialists in the field to obtain their reaction and comment. The notion of the design guide was later abandoned as being somewhat premature; but the comments received were given careful consideration in the present final report. These comments are abstracted in the Appendix, and the author gratefully acknowledges the helpful suggestions, ideas, and experiences contributed by the groups and individuals represented therein.

This technical report has been reviewed and is approved.



C. B. WESTBROOK

Chief, Control Criteria Branch  
Flight Control Division  
AF Flight Dynamics Laboratory

# Contrails

## ABSTRACT

This report is a codification in two parts of conventional aircraft handling qualities criteria. The results of this effort are to serve as an intermediate design guide in the areas of lateral-directional oscillatory and roll control. All available data applicable to these problem areas were considered in developing the recommended new criteria. Working papers were sent to knowledgeable individuals in industry and research agencies for comments and suggestions, and these were incorporated in the final version of this report. The roll handling qualities portion of this report uses as a point of departure the concept that control of bank angle is the primary piloting task in maintaining or changing heading. Regulation of the bank angle to maintain heading is a closed-loop tracking task in which the pilot applies aileron control as a function of observed bank angle error. For large heading changes, the steady-state bank angle consistent with available or desired load factor is attained in an open-loop fashion; it is then regulated in a closed-loop fashion throughout the remainder of the turn. For the transient entry and exit from the turn, the pilot is not concerned with bank angle per se, but rather with attaining a mentally commanded bank angle with tolerable accuracy in a reasonable time, and with an easily learned and comfortable program of aileron movements. In the lateral oscillatory portion of this effort, in defining requirements for satisfactory Dutch roll characteristics, a fundamental consideration is the fact that the motions characterizing this mode are ordinarily not the pilot's chief objective. That is, he is not deliberately inducing Dutch roll motions in the sense that he induces rolling and longitudinal short-period motions. Dutch roll oscillations are side products of his attempts to control the airplane in some other mode of response, and they are in the nature of nuisance effects which should be reduced to an acceptable level. In spite of its distinction as a side effect, adequate control of Dutch roll is a persistent handling qualities research area and a difficult practical design requirement. The difficulties stem from the many maneuver and control situations which can excite the Dutch roll, and from its inherently low damping. Since any excitation of the Dutch roll is undesirable, the effects of disturbance inputs are almost uniformly degrading to pilot opinion rating. Nevertheless, removal of such influence does not eliminate the need for some basic level of damping. A worthwhile approach to establishment of Dutch roll damping requirements is to first establish the basic level, and then to study the varied influences of the disturbance parameters. This approach provides the basis for the material contained in this report.

# Contrails

## CONTENTS

|  | <u>Page</u> |
|--|-------------|
| I. INTRODUCTION . . . . .  | 1           |
| II. CLOSED-LOOP CONSIDERATIONS . . . . .   | 3           |
| III. OPEN-LOOP CONSIDERATIONS . . . . .  | 8           |
| A. Response to Aileron Steps . . . . .   | 8           |
| B. Smooth Aileron Movements . . . . .  | 15          |
| IV. ROLL DAMPING REQUIREMENTS . . . . .  | 21          |
| V. ROLL POWER REQUIREMENTS . . . . .   | 25          |
| VI. "OPTIMUM" GAIN CONSIDERATIONS . . . . .  | 37          |
| VII. CONCLUSIONS . . . . .   | 40          |
| REFERENCES . . . . .   | 43          |
| APPENDIX. COMMENTS RECEIVED ON DRAFT VERSION OF REPORT<br>(STI WP-133-4) . . . . . | 66          |

# Contrails

## TABLES

| <u>Table</u> |   | <u>Page</u> |
|--------------|---|-------------|
| I.           | Data Sources for $K_c/s(T_c s + 1)$ Handling Qualities. . . . . | 47          |
| II.          | Full Aileron Roll Performance of USAF Airplanes . . . . .       | 48          |

## ILLUSTRATIONS

| <u>Figure</u> |  | <u>Page</u> |
|---------------|--|-------------|
| 1.            | "Expected" $T_L$ Versus $T_R$ Relationship . . . . .   | 49          |
| 2.            | Roll Response to a Step Aileron . . . . .  | 50          |
| 3.            | Maximum Performance Bank and Stop. . . . .   | 51          |
| 4.            | Recovery Time and Roll Excursion Following an Impulsive Gust Upset . . . . .                 | 52          |
| 5.            | Stopping Bank Angle and Time Versus Ratio of Stopping to Starting Aileron Angle . . . . .    | 53          |
| 6.            | Acceleration Limiting Effects on Stopping Bank Angle . . . . .                               | 54          |
| 7.            | Bank Angle and Aileron Time Histories for Sidestep . . . . .                                 | 55          |
| 8.            | Theoretical Minimum Times for Sinusoidal Maneuvers Limited by Rate of Roll . . . . .         | 56          |
| 9.            | Ratings Versus Roll Damping—Flight Test, Moving-Base, Fixed-Base with Random Input . . . . . | 57          |
| 10.           | Ratings Versus Roll Damping—Fixed-Base Without Random Input . . . . .                        | 58          |
| 11.           | "Best" Height Control Ratings Versus $-1/Z_w$ . . . . .                                      | 59          |
| 12.           | "Best" Yaw Control Ratings Versus $-1/N_r$ . . . . .   | 60          |
| 13.           | "Best" Pitch Control Ratings Versus $-1/M_q$ . . . . .                                       | 61          |
| 14.           | $T_L$ Versus $\Delta$ Rating Inferred from Handling Qualities Tests. . . . .                 | 62          |
| 15.           | Roll Power—Best Opinion Correlations . . . . .   | 63          |
| 16.           | Marginal Landing-Approach Roll Performance Data of Ref. 24 . . . . .                         | 64          |
| 17.           | Gain at Crossover Frequency, $\omega_c = 2.5$ Rad/Sec. . . . .                               | 65          |

# Contrails

## SYMBOLS

|                 |   |
|-----------------|---|
| b               | Wing span   |
| db              | Decibels  |
| d               | Lateral sidestep displacement   |
| F               | Stick force   |
| g               | Acceleration due to gravity   |
| h               | Altitude  |
| $I_{xz}$        | Product of inertia about x, z axes  |
| $I_x, I_y, I_z$ | Moments of inertia about x, y, z axes, respectively                                 |
| K               | Gain constant   |
| L               | Rolling acceleration due to externally applied torque                               |
| $L_i$           | Variation of L with input or motion quantity particularized by subscript            |
| $L_i'$          | $\frac{L_i + (I_{xz}/I_x)N_i}{1 - (I_{xz}^2/I_x I_z)}$                              |
| m               | $t/T = 1/m$ partitions the sidestep bank angle time history (Eq 19 and 20)          |
| M               | Pitching acceleration due to externally applied torque                              |
| M               | Mach number   |
| $M_i$           | Variation of M with input or motion quantity particularized by subscript            |
| n               | Load factor in g units; ratio of stopping to starting aileron deflection (Sketch 5) |
| $n_o$           | Desired value of n  |
| N               | Yawing acceleration due to externally applied torque                                |
| $N_i$           | Variation of N with input or motion quantity particularized by subscript            |
| $N_i'$          | $\frac{N_i + L_i(I_{xz}/I_x)}{1 - (I_{xz}^2/I_x I_z)}$                              |

# Contrails

|                |   |
|----------------|---|
| P              | Rolling angular velocity about x axis, positive right wing down                 |
| $p_0$          | Steady roll rate  |
| $P_g$          | Gust upsetting impulse, deg/sec   |
| q              | Pitching angular velocity about y axis, positive nose up                        |
| R              | Pilot rating number   |
| s              | Laplace transform, $s = \sigma + j\omega$                                       |
| $t_R$          | Time to recover from a gust upset   |
| $t_{30^\circ}$ | Time to bank $30^\circ$   |
| T              | General first-order time constant; also total maneuver time                     |
| $T_I$          | Pilot-adopted lag time constant   |
| $T_L$          | Pilot-adopted lead time constant  |
| $T_N$          | First-order lag time constant approximation of the pilot's neuromuscular system |
| $T_p$          | Roll-rate-limited maneuver time   |
| $T_R$          | Roll subsidence time constant   |
| $T_s$          | Spiral mode time constant   |
| $T_{\theta_2}$ | Pitch numerator short-period time constant                                      |
| $T_\phi$       | Bank-angle-limited maneuver time  |
| $U_0$          | Linear steady-state velocity along x axis                                       |
| v              | Side velocity, positive to right  |
| $v_e$          | "Indicated" side velocity, $v_e = \sqrt{\rho/\rho_0} U_0 \beta$                 |
| x              | Impulsive acceleration  |
| y              | Lateral stability axis, positive out right wing                                 |
| $Y_c$          | Controlled element transfer function  |
| $Y_p$          | Pilot's quasi-linear describing function  |
| Z              | Vertical acceleration along the Z axis  |
| $Z_i$          | Variation of Z with input or motion quantity particularized by subscript        |

# Contraails

|                |  |
|----------------|--|
| $\beta$        | Sideslip angle, $\beta = v/U_0$  |
| $\delta$       | Control angular deflection   |
| $\delta_a$     | Aileron angular deflection   |
| $\delta_r$     | Rudder angular deflection  |
| $\zeta$        | Damping ratio of linear second-order system particularized by subscript                |
| $\zeta_d$      | Damping ratio of Dutch roll second-order   |
| $\zeta_\omega$ | Damping  |
| $\theta$       | Pitch angle  |
| $\tau$         | Pilot's reaction time  |
| $\phi$         | Roll angle, positive right wing down   |
| $\phi_1$       | Bank angle in 1.0 sec  |
| $\phi_2$       | Bank angle in 2.0 sec  |
| $\psi$         | Heading angular displacement   |
| $\omega$       | Undamped natural frequency of a second-order mode particularized by subscript, rad/sec |
| $\omega_i$     | Input disturbance bandwidth  |

## Subscripts:

|       |  |
|-------|--|
| a     | Aileron  |
| av    | Average  |
| b & s | Bank and stop                                      |
| c     | Controlled element, crossover, or collective pitch |
| d     | Dutch roll   |
| e     | Elevator   |
| g     | Gust   |
| m     | Maximum  |
| o     | Maximum; critical; additional                      |



# *Contraails*

|          |  |
|----------|--|
| p        | Roll rate, or pilot                            |
| q        | Pitch rate                                     |
| r        | Rudder, or yaw rate                            |
| R        | Roll subsidence                                |
| s        | Spiral divergence                              |
| sp       | Short period                                   |
| v        | Side velocity                                  |
| $\beta$  | Sideslip                                       |
| $\delta$ | Control deflection particularized by subscript |
| $\theta$ | Pitch transfer function                        |
| $\phi$   | Roll transfer function                         |

# *Contrails*

# Contrails

## SECTION I

### INTRODUCTION

The study of lateral controllability requirements logically starts with an examination of the simple, ideal, one-degree-of-freedom roll-to-aileron transfer function:

$$\frac{\phi}{\delta_a}(s) = \frac{L_{\delta_a}}{s(s - I_p)} \equiv \frac{L_{\delta_a} T_R}{s(T_R s + 1)} \quad (1)$$

This not only reduces the problem to its most basic level—note that only two quantities need be specified—but serves as a logical point of departure for later considering<sup>1</sup> the implications of the more complete three-degree-of-freedom roll dynamics.

Control of bank angle is a primary piloting task necessary for maintaining or changing the flight path heading. Regulation of the bank angle to maintain heading, especially in the presence of disturbances (e.g., gusts, flight director "noise," etc.), is a closed-loop (tracking) task wherein the pilot applies aileron control as some function of the observed bank angle error. For large heading changes, the turning (steady-state) bank angle, consistent with available or desirable load factors, is attained in a programmed or open-loop fashion; and then regulated through closed-loop control during the major portion of the turn. For the transient turn-entry and turn-exit maneuvers, the pilot is not concerned with bank angle errors per se, but rather with attaining a mentally commanded bank angle with tolerable accuracy, within a reasonable time and with an easily learned and comfortable program of aileron movements. Similar comments apply to bank angle "commands" imposed by the necessity to avoid obstacles or asymmetric ground contact.

Both the closed-loop and open-loop aspects of bank angle control as they relate to desirable levels of roll damping,  $T_R$ , roll power,  $L_{\delta_a} \delta_{a_{max}}$ ,

# *Conclusions*

and gain,  $L_{\delta_R}$ , will be examined. Section II contains the closed-loop discussion; Section III presents some useful open-loop concepts; Section IV combines these results with experimental handling qualities data to arrive at desirable levels of roll damping; Section V presents some collected data and conjectures regarding roll power requirements; and Section VI contains data and analyses pertinent to the question of optimum gain. The conclusions of the study are summarized in Section VII.

## SECTION II

### CLOSED-LOOP CONSIDERATIONS

In exploring the closed-loop implications of ideal roll control, we characterize the pilot's activities by his experimentally observed quasi-linear describing function, fitted to the simple general form\*

$$Y_p(s) = \frac{K_p e^{-\tau s} (T_L s + 1)}{(T_I s + 1)(T_N s + 1)} \quad (2)$$

For the closed-loop problem at hand, lag equalization, the  $(T_I s + 1)$  term, is unnecessary and the neuromuscular lag effects,  $(T_N s + 1)$ , can conveniently be lumped with  $\tau$ . Accordingly, the complete open-loop transfer function in its simplest applicable form is given by

$$Y_p(s) \frac{\phi}{\delta_a}(s) = \frac{K_p e^{-\tau s} (T_L s + 1) L \delta_a T_R}{s(T_R s + 1)} \quad (3)$$

where the value of  $\tau$  has been adjusted for  $T_N$  effects.

For low values of  $T_R$ , corresponding to high roll damping, the controlled-element dynamics,  $Y_c(s) \equiv \phi/\delta_a(s)$ , approach the simple  $K_c/s$  form (i.e., in Eq 1, for  $T_R \rightarrow 0$ ,  $\phi/\delta_a \rightarrow L \delta_a T_R/s$ ). Under these conditions pilot lead is unnecessary for good closure, i.e.,  $Y_p Y_c \doteq K_p K_c e^{-\tau s}/s$ , and the only pilot adaptation required is on the value of his gain,  $K_p$ . For this simplest of all closed loops, the open-loop gain determines the gain-crossover frequency,  $\omega_c$ ; i.e.,  $K_p K_c = \omega_c$ . The corresponding phase

---

\*It is beyond the scope of this report to explain at length the basis for this form, the adjustment rules, etc. The subject is treated from an applications point of view in Refs. 3, 5, 14, 21, 33, and some of the more recent experimental background is given in Refs. 2 and 32, among others.

# Conclusions

margin is given by

$$180^\circ - \angle Y_p(s)Y_c(s) = 90^\circ - 57.3(\tau\omega_c) \quad (4)$$

Since the required pilot adaptation is a minimum, pilot opinion of the  $K_c/s$ -like controlled element is invariably good provided the value of  $K_p$  is in some optimum region, which depends on the muscle groups used in exercising control; and provided the system bandwidth, determined by  $\omega_c$ , is greater than the input disturbance bandwidth,  $\omega_1$ . Both of these auxiliary requirements demand some knowledge of the possible or likely values of  $\omega_c$ .

Recent comprehensive human-response measurements<sup>2</sup> utilizing proven and tested cross-spectral analysis techniques show that for fixed-base, single-axis, tracking tasks the experimentally observed values of  $\omega_c$  are 4.8 rad/sec and 2.9 rad/sec for  $K_c/s$  and  $K_c/s^2$  controlled elements, respectively; and these values are essentially constant with varying input bandwidths provided these bandwidths are less than  $\omega_c$ . Such fairly large values of  $\omega_c$  are directly connected with fairly low phase margins and/or effective  $\tau$ 's (e.g., for  $30^\circ$  phase margin and  $\omega_c = 4.8$ , Eq 4 gives  $\tau$ , including neuromuscular lags, as 0.22). Therefore, if the effective  $\tau$  is increased, as in a real flight situation,<sup>32</sup> we would expect a decrease in  $\omega_c$  for a given phase margin. Even on a fixed-base simulator, the distraction of other tasks will, because of time-sharing, tend to increase  $\tau$  and reduce  $\omega_c$  from the values noted above. Also, if the pilot's muscular and mental "set" is to some extent governed by the achievement of good closed-loop response to a step, as in a commanded maneuver, the optimum phase margin is greater (i.e., the optimum closed-loop damping is higher) than that for achieving minimum rms error, as in "pure" tracking of random disturbances; and this too leads to reduced  $\omega_c$ . These speculations are advanced because there are a number of measurements of varying validity<sup>5,14,56</sup> which indicate that, for handling qualities considerations, values of  $\omega_c$  about  $2 \pm 0.5$  rad/sec are perhaps more realistic than the values observed in the experiments of Ref. 2.

# Conclusions

The basic data of the Ref. 2 study also show that, for all controlled elements tested, whether of form  $Y_C = K_C$ ,  $K_C/s$ , or  $K_C/s^2$ , the complete open-loop describing function,  $Y_p Y_C$ , can be approximated in the crossover region (crossover defined as  $|Y_p Y_C| = 1$ ) by

$$(Y_p Y_C)_{\text{crossover}} \doteq \frac{K_p K_C e^{-\tau' s}}{s} \quad (5)$$

(The primed  $\tau$  indicates that it contains contributions from the actual pilot equalizations used to achieve this crossover condition.) In fact, the validity of the above expression actually extends to frequencies well below crossover (about a decade). For  $Y_C = K_C/s^2$ , the measured pilot leads required to achieve this long stretch of  $K/s$ -like open-loop behavior approach values of  $T_L$  as high as 5. This number is a factor of 2 or more greater than the "reasonable maximum" put forward in Ref. 3. However, it is well supported by the very complete and very consistent data of Ref. 2. It may even be "explainable" on the basis of the pilot's use of stick pulses to control  $K/s^2$  as opposed to stick deflections to control  $K/s$ ; both systems then give pure rate response to the control input. Such an "explanation" is consistent with the data and observations of Ref. 3, and is more palatable (for the large  $T_L$ 's involved) than the opposing view that the pilot mentally processes the displayed displacement signal. Regardless of the "explanation," it appears that for the controlled elements pertinent to both extremes of ideal roll control (i.e.,  $T_R \rightarrow 0$ ,  $T_R \rightarrow \infty$ ) the pilot can readily adapt values of  $T_L$  ranging between zero and 5.

In view of this facility and the basic desirability (for either automatic or manual control) of  $K/s$ -like crossovers, we would expect closed-loop roll control to involve pilot lead adaptation which effectively cancels the roll subsidence mode, i.e., for  $T_L \doteq T_R$  Eq 3 looks like Eq 5. Obviously, in view of the data discussed above,  $T_L$  will not follow  $T_R$  as it approaches infinity ( $Y_C \rightarrow K_C/s^2$ ) but will, instead, approach a maximum value around 5. Also,  $T_L$  will not follow  $T_R$  as it approaches zero ( $Y_C \rightarrow K_C/s$ ) but will, instead, precede it and approach zero as soon as the phase lag

# Conclusions

contributed by  $T_R$  at  $\omega_c$  becomes permissibly small.<sup>33</sup> This expected pilot-adapted  $T_L$  versus  $T_R$  relationship is graphically illustrated by the cross-hatched region of Fig. 1. The extremes shown for  $T_L = 0$  correspond to a  $30^\circ$  phase margin for an assumed  $\tau = 0.2$  and  $1.5 < \omega_c < 2.5$ ; and the variation from the ideal  $T_L = T_R$  for high  $T_R$ 's assumes that inexact matching, to the extent of a two- or three-db kink favoring reduced  $T_L$ 's, is acceptable. Also plotted in Fig. 1 are experimental points taken from Ref. 5. These were obtained through use of a parameter-tracking scheme which made limited on-line adjustments of an analog pilot-model to match the closed-loop performance of the real pilot. Such a system is rather poor at accurately matching low frequency system characteristics and this is reflected in the maximum value of  $T_L$  shown (about 1.4) for  $T_R = \infty$ ,  $Y_c = K_c/s^2$ . This number is much less than that obtained using more sophisticated data analysis techniques in the similar experiments of Ref. 2 discussed above. However, for low values of  $T_L$  (i.e.,  $1/T_L$  corresponding to high frequency) where the parameter tracker is expected to be most accurate, the data do show the expected  $T_L \doteq T_R$  relationship.

One outcome of this adaptive pilot behavior is that the closed-loop performance is relatively insensitive to variations in  $T_R$  (e.g., the simulator tests of Ref. 28). That is, the pilot adapts in such a way as to effectively cancel  $T_R$  and thereby makes all systems look like  $K_c/s$ . Therefore, provided  $\omega_c$  is greater than  $\omega_1$  and  $K_c$  is adjusted to always be near the optimum (i.e., best opinion) gain, we would expect opinion changes with  $T_R$  to be a function only of the  $T_L$  adapted by the pilot. From pilot opinion ratings obtained in connection with the experiments of Ref. 2, an average rating increase (degraded opinion) of about three Cooper<sup>6</sup> points was observed in going from best  $K_c/s$  to best  $K_c/s^2$  (best in the sense of optimum  $K_c$ ). This infers that the incremental pilot rating associated with  $T_L$ 's between zero and about 5 is roughly three points. Thus the rating increment associated with a finite value of  $T_R$  will depend on the pilot-adapted value of  $T_L$  (e.g., Fig. 1) and will vary with  $T_L$  roughly as shown in Sketch 1. Here, because the exact nature of the relationship is to this point unknown, a fairly broad



area is depicted. Later consideration of applicable handling qualities data will, hopefully, be more revealing in this context.

In the meantime it is pertinent to observe that the relationship shown in Sketch 1, which is based on recent experimental human-response measurements and opinion ratings for  $K_C/s$  and  $K_C/s^2$ , is considerably different than that given in Ref. 3 based on similar experiments with a controlled element of form

$$Y_C = \frac{K_C(T\theta_2 s + 1)}{s\left(\frac{s^2}{\omega^2} + \frac{2\zeta}{\omega} s + 1\right)}$$

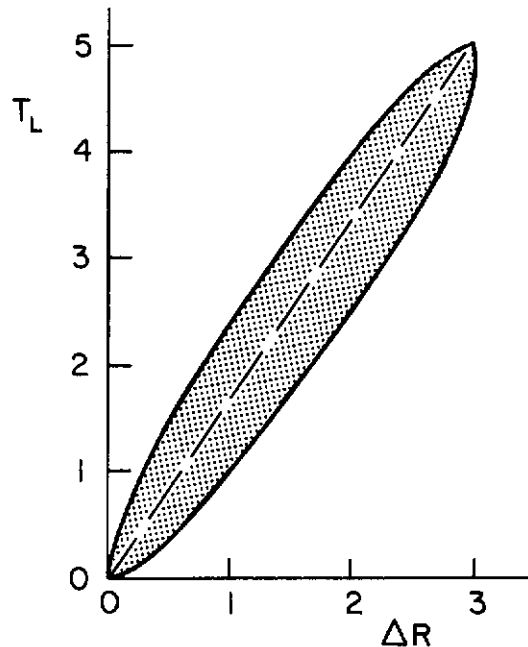

Sketch 1. Approximate Variation of Incremental Rating with  $T_L$

It must be remarked, however, that the data used to obtain the Ref. 3 result do not exhibit the consistency, either internally or with respect to other investigators, which is shown by the Ref. 2 data.

In summary, it appears that pilot rating of closed-loop ideal roll-tracking characteristics will degrade with increasing roll-subsidence time constant,  $T_R$ , because of corresponding changes in the pilot's lead adaptation,  $T_L$ . Regardless of the exact form of Sketch 1, the implications of Fig. 1 are that no pilot lead will be required for  $T_R$  less than about 0.5; therefore for optimum gain we expect no opinion variations for  $T_R$ 's below this value and gradually degraded ratings for increasing  $T_R$ 's above this value. The question of optimum gain will be treated in Section VI.

## SECTION III OPEN-LOOP CONSIDERATIONS

Somewhere in the spectrum of possible and useful programmed roll maneuvers the pilot may encounter undesirable characteristics. To help identify these situations and relate them to the two parameters which govern ideal rolling, we will examine the implications of two types of aileron inputs: the first, abrupt step inputs designed to achieve maximum roll performance; the second, smoothly applied inputs compatible with normal turning maneuvers.

### A. RESPONSE TO AILERON STEPS

The ideal roll response to a series of abrupt changes in aileron deflection can be obtained by linear superposition of the responses to a series of step inputs. The basic rolling response to a step aileron,  $\delta_a(s) = \delta_a/s$ , in terms of the steady rolling velocity,  $p_0 = L\delta_a T_R$ , is obtained by the inverse Laplace transform of Eq 1; viz:

$$\frac{p}{p_0} = 1 - e^{-t/T_R} \quad (6)$$

Integrating from time = zero to time = t,

$$\frac{\phi}{p_0} = t - T_R(1 - e^{-t/T_R})$$

and for nondimensional time,  $t/T_R$ ,

$$\frac{\phi}{p_0 T_R} = \frac{t}{T_R} - (1 - e^{-t/T_R}) \quad (7)$$

These well-known relationships, in addition to their utility as basic building blocks, are of interest in their own right because there

# Contrails

are a number of requirements written in terms of the time to bank or the roll rate achievable in a given time, as will be discussed in Section V. In the meantime it is pertinent to note that these results for a pure sharp-edged step can be used to approximate responses to input forms more compatible with reality by simply adding a suitable time increment (provided the times of interest are large with respect to the increment). For example, for a ramp-like input which is limited to a maximum  $\delta_a$ , as sketched below,  $\Delta t = 1/2$  (time required to get to maximum  $\delta_a$ ) should be added to the times given by Eqs 6 and 7.

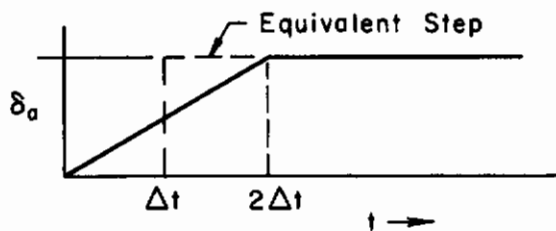

Sketch 2. Equivalent Step Input

## 1. Bank and Stop

Bank and stop is another maneuver sometimes used to specify roll control requirements. Since it is a maximum-performance maneuver, full aileron travel will be used both to initiate and to stop the motion, as sketched. The corresponding additive step inputs, also sketched,

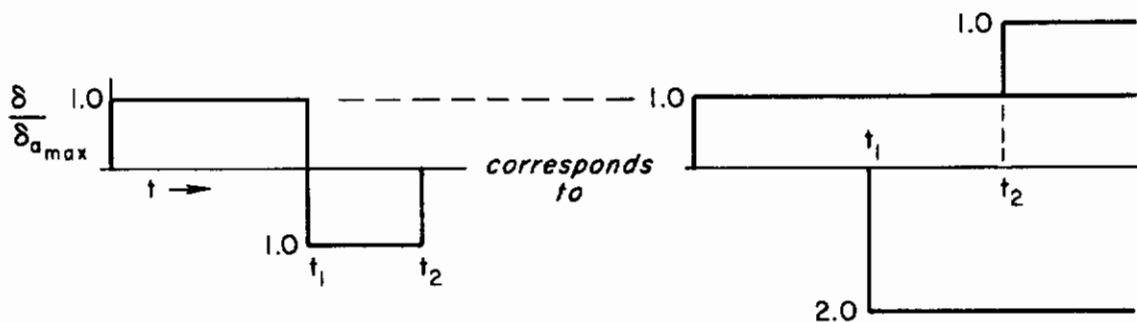

Sketch 3. Maximum-Performance Bank and Stop Aileron Inputs

give rise by superposition to the rolling response, for time  $t > t_2$ ,

# Contrails

$$\begin{aligned} \frac{p(t)}{p_0} &= 1 - e^{-t/T_R} - 2\left[1 - e^{-(t-t_1)/T_R}\right] + 1 - e^{-(t-t_2)/T_R} \\ &= e^{-t/T_R} \left(2e^{t_1/T_R} - e^{t_2/T_R} - 1\right) \end{aligned} \quad (8)$$

and  $p$  is identically zero for  $t > t_2$  when

$$2e^{t_1/T_R} = 1 + e^{t_2/T_R} \quad (9)$$

The bank angle attained at time  $t_2$  is given by

$$\begin{aligned} \frac{\phi}{p_0} &= \left[t + T_R e^{-t/T_R}\right]_0^{t_2} - 2\left[t + T_R e^{-(t-t_1)/T_R}\right]_{t_1}^{t_2} \\ &= 2t_1 - t_2 + T_R \left[1 + e^{-t_2/T_R} \left(1 - 2e^{t_1/T_R}\right)\right] \end{aligned}$$

and applying the condition of Eq 9 makes the bracketed term go to zero and results in (letting  $t_2 = t$ )

$$\frac{\phi}{p_0 T_R} = \frac{2t_1}{T_R} - \frac{t_2}{T_R} = 2 \ln \left( \frac{1 + e^{t/T_R}}{2} \right) - \frac{t}{T_R} \quad (10)$$

This result gives the bank angle as a function of maneuver duration,  $t$ , for an optimum bank and stop maneuver.

Equations 6, 7, and 10 are plotted in Fig. 2, which also contains a graph of the average roll rate,

$$\frac{p_{av}}{p_0} = \frac{\phi}{p_0 t} = \frac{\phi}{p_0 T_R} \times \frac{T_R}{t}$$

Figure 3 presents additional bank-and-stop characteristics which pertain largely to the bank angle displacement,  $\Delta\phi$ , required to stop.

It is quite difficult to find in these characteristics a generally applicable indication of a maximum desirable  $T_R$ , as we inferred for the closed-loop situation. Instead, there is a more or less continuous performance improvement as  $T_R$  is reduced, and the nondimensional maneuver

# Conclusions

time,  $t/T_R$ , is increased. One metric that suggests itself is the notion of a diminishing return for increasing values of  $t/T_R$ . For example, to attain 90 percent of the maximum realizable  $p/p_0$  requires  $t/T_R > 2.3$  (Fig. 2). But this results in a stopping bank angle relative to the total,  $\Delta\phi/\phi$ , nowhere near a desired minimum (Fig. 3) and, in terms of  $\Delta\phi/p_1 T_R$ , where  $p_1$  is the roll rate at initiation of the stop maneuver, about 90 percent of maximum. If the stopping bank angle itself is taken as a measure of "snappy" response, then perhaps the maximum value of  $\Delta\phi/p_1 T_R \doteq 0.31$  should be set to correspond to a given absolute displacement, say,  $\Delta\phi \doteq 10^\circ - 20^\circ$ . But this only serves to limit the product,  $p_1 T_R$ , to a value between about 0.5 and 1.0 without revealing a desirable balance between  $p_1$  and  $T_R$ .

## 2. Recovery from Gust Upsets

Consider now that an impulsive gust disturbance is encountered and that its major effect is about the roll axis. Then, representing the impulsive acceleration x time by  $P_g$  yields a gust-response time history in roll given by

$$\phi(t) = \mathcal{L}^{-1} \frac{P_g}{s(s + 1/T_R)} = P_g T_R (1 - e^{-t/T_R}) \quad (11)$$

For this time response, nondimensionally identical to that shown for  $p/p_0$  in Eq 6 and Fig. 2, the bank angle approaches and remains near maximum for  $t/T_R > 3$ . Thus, supposing values of  $T_R$  near 0.5, the simulated upsets, which sometimes serve as the starting point for roll-control evaluation maneuvers,<sup>24</sup> correspond roughly to those existing about 1.5 sec after the impulsive encounter.

The roll response due to corrective full aileron, Eq 7, algebraically added to the gust response, Eq 11, gives the complete bank angle time history,

$$\phi(t) = p_0 T_R \left( \frac{t}{T_R} - 1 + e^{-t/T_R} \right) - P_g T_R \left[ 1 - e^{-(t_1 + t)/T_R} \right] \quad (12)$$

# Contrails

Here, as illustrated at right,  $t$  is measured from the time at which the step aileron input effectively starts; and  $t_1$  is the time over which the impulse response has acted up to  $t = 0$ . The time to recover,  $t_R$ , which is the value of  $t$  corresponding to  $\phi = 0$ , is given by the relationship

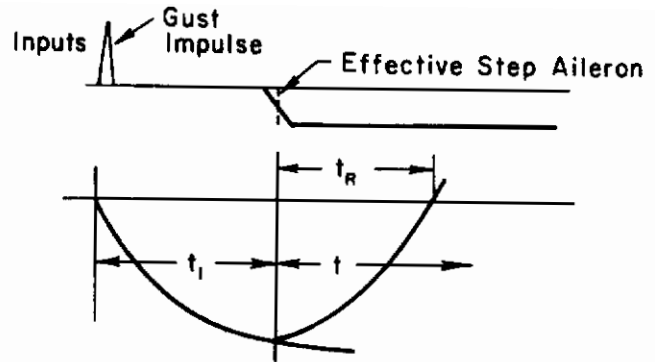

Sketch 4. Recovery from a Gust Upset

$$\frac{t_R}{T_R} + e^{-t_R/T_R} \left( 1 + \frac{P_g}{P_0} e^{-t_1/T_R} \right) = \frac{P_g}{P_0} + 1 \quad (13)$$

The maximum bank angle excursion during upset and recovery corresponds to  $p = 0$ , which, differentiating Eq 12, occurs when

$$p = 0 = p_0 \left( 1 - e^{-t/T_R} \right) - P_g e^{-(t_1 + t)/T_R}$$

or when

$$\frac{t}{T_R} = \ln \left( 1 + \frac{P_g}{P_0} e^{-t_1/T_R} \right)$$

The value of  $\phi_{\max}$ , using these relationships in Eq 12, is given by

$$\frac{\phi_{\max}}{P_0 T_R} = \ln \left( 1 + \frac{P_g}{P_0} e^{-t_1/T_R} \right) - \frac{P_g}{P_0} \quad (14)$$

Equations 13 and 14 are plotted in Fig. 4 where it may be seen that  $t_R/T_R$  is relatively insensitive to the value of  $t_1/T_R$ , especially for high values of  $P_g/p_0$ ; and the maximum bank angle excursion is more strongly, but not overwhelmingly, influenced by reasonable values of  $t_1/T_R$ . Again, it is clear that, for a given value of  $p_0$ , there will be a progressive improvement in performance as  $T_R$  is reduced.

### 3. Acceleration-Limited Stops

Coming back now to the notion of stopping displacement, let's consider a simplified situation in which steady (but not necessarily maximum) roll rate is stopped by an abrupt aileron reversal of arbitrary

# Contrails

magnitude. Referring to the sketch below, and analogous to Eqs. 6 and 7, for  $t > t_1$  (time starts at  $t_1$ ),

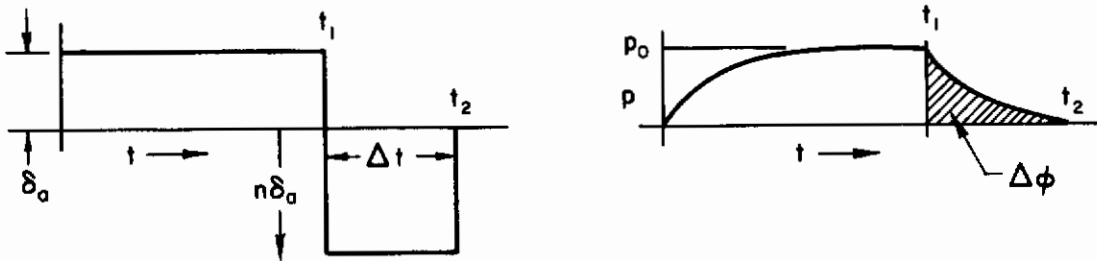

Sketch 5. Quick-Stop Maneuver

$$\frac{p}{p_0} = 1 - (n+1)(1 - e^{-t/T_R}) = -n + (n+1)e^{-t/T_R} \quad (15)$$

$$\frac{\Delta\phi}{p_0} = -nt + (n+1)T_R(1 - e^{-t/T_R})$$

But for  $p = 0$  from Eq 15,

$$e^{-t/T_R} = \frac{n}{n+1} \quad ; \quad \frac{t}{T_R} = \ln\left(\frac{n+1}{n}\right)$$

$$1 - e^{-t/T_R} = \frac{1}{n+1}$$

whereby

$$\frac{\Delta\phi}{p_0 T_R} = 1 - n \ln\left(\frac{n+1}{n}\right) \quad (16)$$

This function, plotted in Fig. 5 (note that at  $n = 1$  the value of  $\Delta\phi/p_0 T_R$  is the same as the maximum  $\Delta\phi/p_1 T_R$  of Fig. 3) indicates that increasing  $n$  beyond a value of about 2 has a diminishing return; we postulate therefore that the pilot will seldom use aileron deflections to stop rolling motions greater than about twice the initiating deflection. However, even neglecting stick force considerations, the pilot may not elect to use such an "optimal" program because of the attendant high rolling accelerations. If the value of  $n$  is limited by some comfortable level of  $\dot{p}$ , then the reduced stopping angles inherent in

# Contrails

decreased  $T_R$ 's (for  $\Delta\phi/p_0 T_R = \text{constant}$ , corresponding to  $2 < n < 3$ ) may not in fact be realizable.

To examine this proposition, notice from Sketch 5 that  $\dot{p}_{\text{max}}$  occurs at the aileron reversal point or, in terms of Eq 15, at  $t = 0$ . That is, differentiating Eq 15 and setting  $t = 0$ ,

$$\frac{\dot{p}_{\text{max}}}{p_0} = -\frac{n+1}{T_R} \quad (17)$$

Suppose now there is a critical value,  $T_{R_0}$ , below which the desired value,  $n_0$ , is not comfortably usable because of the attendant high (and limiting) roll acceleration:roll rate ratio,  $(-\dot{p}_{\text{max}}/p_0)_{\text{limit}}$ . Then  $n$  will be limited to some value less than  $n_0$  as  $T_R$  decreases below  $T_{R_0}$ , i.e., from Eq 17,

$$\frac{n+1}{n_0+1} = \frac{T_R}{T_{R_0}} \quad \text{for} \quad \frac{T_R}{T_{R_0}} < 1$$

Recognizing that the nondimensional stopping bank angle,  $\Delta\phi/p_0 T_R$ , is a function of  $n$  (Fig. 5) and therefore of  $T_R/T_{R_0}$  permits the construction of Fig. 6. Here, without considering acceleration effects the stopping angle decreases linearly with decreasing  $T_R$  or  $T_R/T_{R_0}$ . However, if stopping accelerations become critical, then performance does not improve with decreasing  $T_R$  below the critical values of  $T_{R_0}$  and  $\Delta\phi_0$ , but instead levels out as shown. The vertical rise in  $\Delta\phi/\Delta\phi_0$  for low values of  $T_R/T_{R_0}$  is associated with  $n \rightarrow 0$ , which implies that the stopping and starting accelerations are identical (see Sketch 5). Therefore this region is of no practical interest since the pilot will reduce his initiating aileron deflection to keep roll acceleration within comfortable limits.

If "snappy" open-loop bank angle control is any criterion, we would, on the basis of these results, expect to find little change in open-loop performance, or rating for  $T_R < T_{R_0}$ . The value of  $T_{R_0}$  is, however, not a universal constant, but varies largely because of  $p_0$  (Eq 17). That is, even assuming a given critical  $\dot{p}_{\text{max}}$  and a desired  $n \doteq 2$ ,  $T_{R_0}$  is still linearly dependent on  $p_0$ , the roll rate from which the stop maneuver is initiated. Thus, for classes of airplanes not expected to maneuver



# Contrails

violently, where the normally desired maximum roll rate is low (not the maximum attainable, but the maximum used), the value of  $T_{R_0}$  will also be low, and vice versa of course. A rough indication of the probable magnitude of maximum  $T_{R_0}$  will be developed in Section IV in connection with available handling qualities data. In the meantime it is important to note that these conjectures imply that the absence of motion effects (as in a fixed-base simulator) may alter the pilot's opinion of "good" or "acceptable"  $T_R$ 's.

## B. SMOOTH AILERON MOVEMENTS

While there is a large variety of possible maneuvers worthy of study it is suggested in Ref. 5 (and earlier works referenced therein) that the "sidestep" is representative of the most severe lateral maneuver pilots ordinarily wish to perform "smoothly." This maneuver, illustrated in Sketch 6 (from Ref. 7) is required to eliminate the lateral displacement between the airplane's flight path and the runway centerline which

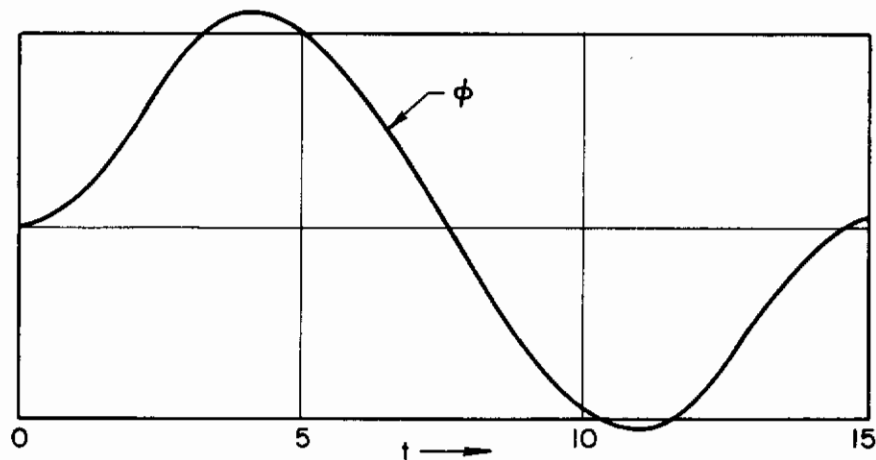

Sketch 6. Bank Angle Time History During "Sidestep"

may confront the pilot on breakout from an instrument letdown. Because of the proximity to the ground and the low airspeeds involved, the maneuver is smoothly performed and is in general (i.e., for all aircraft types) restricted by the pilot to values of  $\phi$  less than about  $30^\circ - 35^\circ$  (Ref. 10).

# Contrails

While such maneuvers are surely not performed in a completely open-loop fashion, the open-loop aspects seem to predominate over the closed-loop. Whatever the actual partitioning may be, it is highly instructive to examine the (open-loop) aileron input pattern required to obtain the nearly sinusoidal bank angle time history sketched. As might be anticipated, the input pattern depends on the ratio of  $T_R/T$ , where  $T$  is the total maneuver time. The nature of this dependence and its implications can most easily be shown by constructing a time history in  $\phi$  which has smooth and consistent values of the derivatives  $\dot{\phi}$  and  $\ddot{\phi}$  associated with it; the corresponding values of  $\delta_a(t)$  are then given by Eq 1 in the time domain, i.e.,

$$L_{\delta_a} \delta_a(t) = \ddot{\phi}(t) + \frac{1}{T_R} \dot{\phi}(t) \quad (18)$$

Figure 7a presents assumed time histories of  $\phi$ ,  $\dot{\phi}$ , and  $\ddot{\phi}$  normalized with respect to  $p_{max}$ , and Fig. 7b the corresponding required aileron motions. (Similar results are presented in Refs. 8 and 9 for a smooth bank and stop maneuver.) The analytic forms used to generate Fig. 7a are

$$\begin{aligned} \dot{\phi}\left(\frac{t}{T}\right) &= A(1 - \cos m\pi \frac{t}{T}) \quad \text{for} \quad 0 < \frac{t}{T} < \frac{1}{m}; \quad 1 - \frac{1}{m} < \frac{t}{T} < 1 \\ \dot{\phi}\left(\frac{t}{T} - \frac{1}{m}\right) &= -B + C \cos \frac{2m\pi}{m-2} \left(\frac{t}{T} - \frac{1}{m}\right) \quad \text{for} \quad \frac{1}{m} < \frac{t}{T} < 1 - \frac{1}{m} \end{aligned} \quad (19)$$

where the constants are determined by the boundary conditions:

$$\begin{aligned} \text{at } \frac{t}{T} = \frac{1}{m} \quad \dot{\phi}\left(\frac{t}{T}\right) &= \dot{\phi}\left(\frac{t}{T} - \frac{1}{m}\right) \\ \ddot{\phi}\left(\frac{t}{T}\right) &= \ddot{\phi}\left(\frac{t}{T} - \frac{1}{m}\right) \\ \text{at } \frac{t}{T} = \frac{1}{2} \quad \phi\left(\frac{t}{T} - \frac{1}{m}\right) &= 0 \\ \dot{\phi}\left(\frac{t}{T} - \frac{1}{m}\right) &= p_{max} \end{aligned} \quad (20)$$

The resulting values are

$$A = -\frac{m-2}{2m} p_{max}, \quad B = -\frac{p_{max}}{m}, \quad C = -\frac{m-1}{m} p_{max}$$

$$\text{and } m = 3 + \sqrt{5} = 5.236$$

# Conclusions

It can be appreciated from Fig. 7 that as  $T_R/T$  increases, the correspondence between what the pilot is doing with the ailerons and what the airplane is doing in roll gradually disappears. For example, at  $T_R/T = 0.15$  the phasing between aileron and roll rate is so bad that at maximum aileron displacement ( $t/T = 0.403$ ) the roll rate is only about 65 percent of the maximum finally achieved, and the maximum itself is only  $1/1.66 \doteq 60$  percent of the potential roll rate given by  $L\delta_a\delta_a T_R$ . Also, the second aileron zero-crossing at  $t/T = 0.57$  occurs when the bank angle is only about 60 percent of the desired maximum value. Other aspects of the mismatch between the aileron and rolling time histories as  $T_R/T$  increases could be cited; but it must already be fairly clear that the possibility of smoothly performing the desired maneuver largely disappears for  $T_R/T$  greater than about 0.1. As a matter of fact, analysis of the data presented in Ref. 10 shows that, based on isolated maneuvers, the highest value of  $T_R/T$  used in the flight tests reported was about 0.09. Based on average maneuver times for each of the aircraft involved, the maximum value of  $T_R/T$  was about 0.075.

Another influence on maneuver time is the lateral displacement required or desired as a result of the maneuver. This can be computed approximately as in Ref. 10 by considering the  $\phi$  motion to be a pure sinusoid, i.e.,

$$\phi \doteq \phi_{\max} \sin 2\pi \frac{t}{T} \quad (21)$$

Then, for the zero sideslip conditions of interest,

$$\dot{y}(t) \doteq U_0 \psi(t) \doteq U_0 \int_0^t \frac{g}{U_0} \phi(t) dt \doteq \frac{g\phi_{\max} T}{2\pi} (1 - \cos 2\pi \frac{t}{T})$$

and the lateral displacement,  $d$ , is

$$d \doteq \int_0^T \dot{y}(t) dt \doteq \frac{g\phi_{\max} T^2}{2\pi} \left[ t - \frac{T}{2\pi} \sin 2\pi \frac{t}{T} \right]_0^T = \frac{g\phi_{\max} T^2}{2\pi} \quad (22)$$

# Contrails

For small required displacements the value of  $\phi_{\max}$  will not reach the maximum used for large displacements ( $30^\circ - 35^\circ$ ) but will, instead, be limited by available roll rates. From Eq 21 the maximum roll rate used in the sinusoidal maneuver is

$$p_{\max} = \frac{2\pi}{T} \phi_{\max}$$

and substituting for  $\phi_{\max}$  in Eq 22,

$$d = \frac{g p_{\max} T^3}{4\pi^2} \quad (23)$$

If we correct the values of T given by Eqs. 22 and 23 for the additional time,  $t_0$ , between the start (and stop) of the maneuver and the attainment of (and recovery from) the sinusoidal motion assumed in Eq 21, we get

$$\begin{aligned} T_p &= 2t_0 + \left( \frac{4\pi^2 d}{g p_{\max}} \right)^{1/3} \\ T_\phi &= 2t_0 + \left( \frac{2\pi d}{g \phi_{\max}} \right)^{1/2} \end{aligned} \quad (24)$$

for the roll-rate-limited and bank-angle-limited maneuver times, respectively. These simplified relationships, plotted in Fig. 8 for typical values, are shown in Ref. 10 to correlate quite well with experimentally observed maneuver times, and the corresponding maximum bank angles and available roll rates.

Reference 10 notes further that whereas short-maneuver-time performance would be improved by more abrupt aileron motions, these were not apparently used by either the RAE or the airline pilots who flew the fourteen aircraft involved in the Ref. 10 tests. Furthermore, the RAE group were instructed to perform the most rapid maneuver possible consistent with normal safety, whereas the airline pilots were merely asked to use techniques normally employed during bad weather commercial operations. There was remarkable consistency between the pilot groups and among the fourteen aircraft, which covered a weight range from 9500 to 115,000 lb, wing spans between 33 and 142 ft, wing loadings between 23 and 62 lb/ft<sup>2</sup>,

# Contrails

and approach speeds between 90 and 135 kt. The tests were all conducted in good visibility and it is conceivable that under more adverse weather conditions, smaller maximum bank angles would have been used.

Figure 8 shows that from the standpoint of  $p_{\max}$  roll performance, the short maneuver times will be critical. The time available for maneuver is of course inversely proportional to airspeed and directly proportional to the breakout altitude (ceiling). Present trends toward increased speeds and reduced minimums can only be detrimental in reducing the available maneuver time. In fact, if the sidestep maneuver is to be completed before the initiation of the flare, the time available rapidly approaches zero for minimums approaching 100 ft. (This statement is especially true if flares are normally initiated at about 100 ft altitude, as indicated in Ref. 11.) Under these circumstances no reasonably available roll performance will suffice and the only recourse is to reduce lateral errors at breakout to values compatible with zero maneuvering.

Presumably this state of affairs is not imminent (operationally at least) and lateral errors must still be corrected. To get a better appreciation for possible payoffs due to increased rolling performance, consider the time increment,  $\Delta T = T_p - T_\phi$ . From Fig. 8 it may be seen that this increment remains fairly constant for a reasonably large variation in displacement,  $d$ , for the low maneuver times which are critical; therefore its maximum value (with respect to variations in  $d$ ) is generally applicable to this region. This maximum, obtained by manipulating Eq 24, is given by

$$\Delta T_{\max} = \frac{8\pi}{27} \frac{\phi_{\max}}{p_{\max}} = 0.931 \frac{\phi_{\max}}{p_{\max}} \quad (25)$$

Obviously, increasing  $p_{\max}$  without limit will result in negligible improvement at great cost—a very poor payoff. A more reasonable design approach is to equate the time increment to the additional maneuver distance required,  $U_0 \Delta T_{\max}$ ; or to consider the percentage increase in maneuver time and distance. The former seems more reasonable in that it emphasizes the desirability of reduced approach speeds,

# Contrails

whereas the latter does not. If, accordingly, we consider an increment of 500 ft a reasonable price to pay for a limited roll rate, we get an allowable  $\Delta T_{\max} \doteq 2$  sec (for  $U_0 = 250$  ft/sec); and, for  $\phi_{\max} \doteq 30^\circ$ , a required minimum  $p_{\max}$  of about  $15^\circ/\text{sec}$ . This value coincides with that recommended, on the basis of pilot acceptance, in Ref. 10.

Of course the  $p_{\max}$  actually achieved will approach the maximum steady-state value only if  $T_R/T$  is reasonably small, as noted above. However, as also noted above, the postulated smooth maneuver cannot be executed unless  $T_R/T$  is small (say, less than about 0.075).

# Contrails

## SECTION IV

### ROLL DAMPING REQUIREMENTS

With our theoretical background established, we now turn to a consideration of available handling qualities experimental data. In this section we will examine such data as are relevant to the determination of desirable roll damping. To include as wide coverage as possible, we note that there are situations other than ideal roll control which are characterized by a transfer function of the form

$$Y_c = \frac{K_c}{s(T_c s + 1)} \quad (26)$$

These situations occur during hovering flight for VTOL aircraft and helicopters<sup>21</sup> as reflected in the altitude, heading, and pitch (for  $M_u = 0$ ) control transfer functions,

$$\frac{h}{\delta_c} \doteq \frac{-Z_{\delta_c}}{s(s - Z_w)} \quad ; \quad \frac{\psi}{\delta_r} \doteq \frac{N_{\delta_r}}{s(s - N_r)} \quad ; \quad \frac{\theta}{\delta_e} \doteq \frac{M_{\delta_e}}{s(s - M_q)} \quad (27)$$

Accordingly, our search for applicable data includes the VTOL and helicopter handling qualities area despite our primary concern with conventional airplanes. Table I summarizes the sources of applicable data and the conditions under which they were obtained.

Figure 9 presents the data felt to be most directly pertinent to the question of roll damping requirements—those for roll control. In general, each of the data points plotted is that yielding the minimum (best) rating, as influenced by control power variations, for the given value of  $T_R$  (some exceptions are noted). The trends are gratifyingly uniform in terms of rating increments as a function of  $T_R$ . For example, all the plots show that, for increasing  $T_R$ , rating degradations first

# Conclusions

appear at a value of  $T_R$  somewhere between 0.5 and 1.0. Also, the maximum increment in rating in going from very low to very high values of  $T_R$  is about 3 to 3-1/2 points. These results are completely consistent with the expectations expressed in Section II based on closed-loop considerations. However, some of the data clearly involve open-loop qualities (see Table I) and it is not obvious why simple closed-loop analysis should so successfully predict the observed results. Before attempting to answer this and similar questions which may arise, let's first take a look at the remaining data.

Figure 10, although also roll control data, shows a different picture of incremental rating with decreasing  $T_R$ . Now there is a steady improvement in rating down to values as low as  $T_R = 0.1$ . These trends obtained in tests involving neither motion nor random inputs are, however, not inconsistent with the open-loop abrupt-aileron analyses presented in Section III. There we noted that there is "a more or less continuous performance improvement as  $T_R$  is reduced." The Ref. 23 data, which support these general trends with decreasing  $T_R$ , are especially noteworthy because of an apparent favorable shift in rating. These data, obtained in a simulation of supersonic transport cruise conditions ( $M = 3.0$ ,  $h = 70,000$  ft), seem to indicate that pilots are willing to accept much larger roll time constants for this type of operation. However, this very limited evidence of a size or mission effect on acceptable  $T_R$ 's is not supported by the moving-base results of Ref. 57 (cross-hatched area in Fig. 9) which simulated operating conditions identical to those of Ref. 23.

Figures 11 -13 present available data on other tasks involving controlled elements of the form given by Eq 26. Again, for those data which extend into the region below  $T_C = 1$  there is a leveling off of pilot rating.

The salient facts emerging from an examination of these plots and the related test conditions given in Table I are:

1. All data obtained in the presence of random disturbance inputs or, in their absence, with motion effects present show the same rating trends with time constant. These



# Conclusions

trends disclose a basic insensitivity to time constants less than about 0.5-1.0.

2. All data obtained in the absence of both motion effects and random disturbance inputs show continuing sensitivity to decreasing time constants as low as 0.1.

These facts are consistent with the theoretical notions developed in Sections II and III. For example, we observed earlier that for closed-loop tasks involving tracking of a random input we would expect no rating improvement for  $T_R$ 's less than about 0.5. We also noted that for open-loop control there would be a gradual improvement in performance as  $T_R$  was reduced, provided there were no limiting acceleration effects.

On this last point there is only one set of data, the Ref. 12 tests, which can be singled out as being definitely influenced only by motion effects for low values of  $T_R$ . Furthermore, these tests included both moving-base and fixed simulations (Figs. 9 and 10), and the differences between these are consistent with the above-noted general conclusions. Accordingly, we would say that for the moving-base simulation the critical value of  $T_R$  (that at which acceleration-limiting appears) is about one. That is, the leveling out of rating with decreasing  $T_R$  shown in Fig. 9, when viewed in the light of Fig. 6, results in an estimated value of  $T_{R0} \doteq 1$ . From Eq 17 and taking  $n \doteq 2$ , the corresponding critical roll-acceleration-to-roll-rate ratio would be  $\dot{p}_{max}/p_0 \doteq 3$ . To check this result we note that the comparative data and the associated discussion of motion effects given in Ref. 12 indicate that for "values (of  $\dot{p}$ ) greater than about 10 rad/sec<sup>2</sup>...the forces on the pilot, which arise from the angular accelerations, hinder his ability to control precisely..." Further, the "best" values of  $L\delta_a \delta_{a_{max}}$  corresponding to the data plotted in Figs. 9 and 10 convert in the fixed-base case (Fig. 9 of Ref. 12) to an almost constant steady rolling velocity,  $p_0 = T_R L\delta_a \delta_{a_{max}}$  of about 4 rad/sec for  $T_R \leq 1$ . These two numbers yield a value of  $\dot{p}_{max}/p_0 \doteq 2.5$ , which is in quite good agreement with that obtained above ( $\doteq 3$ ) from the consequences of identifying the value of  $T_{R0}$ . This shows that the data are roughly self-consistent on the basis of the acceleration-limited open-loop model derived in Section III-A-3. However, it also leads to the expectation

# Conclusions

that similar studies conducted, not for fighter-type, but, say, for transport-type aircraft would yield a lower value of  $T_{R_0}$  because of possibly lower desirable values of  $p_0$ .

For the closed-loop model we are now in a position to better define the  $T_L$  versus  $\Delta R$  relationship roughly depicted in Sketch 1. That is, using Fig. 1 to estimate  $T_L$  for a given value of  $T_R$  and the Fig. 9 data for  $\Delta R(T_R)$ , we get the points shown in Fig. 14. Here the vertical dashes represent the uncertainties involved in estimating  $T_L$  from Fig. 1. Unfortunately, the scatter resulting from this process offers little improvement over the crude guess of Sketch 1.

The general conclusions which derive from the data and the analyses are:

1. Fixed-base simulations which employ random inputs to disturb the "airplane" in roll offer the simplest means of determining the valid effects of roll damping on pilot rating trends. This result is in line with the notion that closed-loop tracking tasks are generally more demanding as regards system dynamics than open-loop tasks.
2. Values of  $T_R$  below about 0.5 to 1.0 do not result in improved pilot ratings.
3. The maximum value of  $T_R$  considered "satisfactory" (rating of 3-1/2) for valid tests (Fig. 9) appears to be about 1.3. This value is consistent with the faired data of Ref. 12 and the limits proposed in Ref. 22 which require  $T_{R_{max}} \leq 1.3$  or 1.5, depending on airplane configuration and class.

Conclusion 2 does not reflect possible rating improvements due to the reduced values of  $|\phi/\beta|$  which result from decreasing values of  $T_R$ . As discussed in Ref. 1, there are a large variety of  $|\phi/\beta|$  "effects" which require careful evaluation when the real, three-degree-of-freedom, lateral-directional motions are considered. Also, as is clear from the gust recovery analysis of Section III-A-2, small values of  $T_R$  are helpful in preventing large gust upsets and in effecting quick recovery (except for asymmetric vertical gusts where  $P_g$  is proportional to  $1/T_R$ ). However, all such side effects do not impose intrinsic requirements on the value of  $T_R$ , because there are other (preferred) ways of countering them.

## SECTION V

### ROLL POWER REQUIREMENTS

The maximum rolling moments obtainable with full aileron displacement or maximum pilot force must in general be sufficient to:

1. Balance the airplane under all conditions of aerodynamic, inertial, or power-plant asymmetries
2. Maintain attitude in steady side winds or deliberate sideslips
3. Maintain or quickly recover attitude in gusty air
4. Permit rapid recovery from spins
5. Permit crosswind landings and takeoffs
6. Perform required maneuvers consistent with the airplane's effective utilization

The relative magnitude of the aileron power required to cope with each or combinations of the above requirements obviously varies with configuration details and operational type. In spite of this there are very few current airplanes which, designed to meet the Item 6 "requirement," expressed as a pilot's "desire," fail to meet any of the others. This may stem from the pilot's basic concern with providing for Items 1-5 and his corresponding assessment of desirable "maneuvering" characteristics. At any rate, in practice, this leads to the specification of aileron power in terms of "desirable rolling characteristics as expressed by a variety of metrics, e.g., maximum steady roll rate,  $p_o$ , or wing-tip helix angle,  $p_o b / 2U_o$ ; bank angle attainable in a given time with or without stopping; or average roll rate for a specified time interval, or for a specified roll displacement, etc. Such over-all criteria, which have the virtue of simplicity, may have unduly penalized certain current configurations and may on the other hand be inadequate for some future designs.<sup>7</sup>

# Contrails

It is important therefore somehow to separate the considerations of Items 1-5 that consciously or unconsciously get into the Item 6 category. The point is that all the above-listed considerations except Item 6, and to some extent Item 3, are determinable through standard engineering procedures. If we knew what "desirable" —presumably, therefore, required— maneuvers were (Item 6), and if we had a metric and a design procedure for determining adequate recovery from gust upsets (Item 3), we could, by also routinely considering Items 1, 2, 4, and 5, obtain a clear picture of realistic roll power requirements. Accordingly, the material which follows is devoted to an exploration of the troublesome Item 6 and Item 3 requirements. The first is treated under the heading of "Combat Maneuvering Situations"; and, because recovery from gusts is most critical during landing approach, the second is treated under "Landing Approach Considerations." Also included in the latter are some aspects of maneuvering requirements for approach conditions.

**Combat Maneuvering Considerations.** In addition to trying to eliminate extraneous considerations from desirable maneuvering characteristics, we must also define the metric most descriptive of pilot desires. In both respects the data of Ref. 12 (see Table I) are invaluable. In the first place the pilot's ratings were entirely related to his assessment of "desirable" combat roll performance; and secondly the ratings were shown (in Fig. 17 of Ref. 12) to correlate with bank angle achievable in one second provided  $T_R$  were less than about 1.3. This correlation is also shown in a slightly different presentation in Fig. 15. Here the Ref. 12 points used in Fig. 9, those for best opinion at a given level of  $T_R$ , are plotted on the  $L\delta_a \delta_{a_{max}}$  vs  $T_R$  grid (symbols  $\odot$ ,  $\square$ ). Lines of constant bank angle in one second,  $\phi_1$ , and maximum roll rate,  $p_0$ , are parallel to the heavy reference lines shown (for  $\phi_1 = 1$  rad, and  $p_0 = 1$  rad/sec) and displaced vertically so that  $L\delta_a \delta_a = \phi_1 (L\delta\delta)_{ref}$  or  $p_0(L\delta\delta)_{ref}$ . We see therefore that  $\phi_1 = 1.8$  rad =  $100^\circ$  comes very close to the kind of rolling performance the pilots find most desirable for fighter aircraft\* (i.e., matches

---

\*Reference 58, received just prior to final edition of this report, shows correlation of the Ref. 12 faired boundaries with various bank and stop maneuvers. The satisfactory boundary corresponds, for  $T_R < 0.8$ , to bank and stop of 1.5 rad in 2 sec.

# Contrails

the Ref. 12 data). Furthermore this result, except for the scatter in unfaired data points selected, is essentially independent of the value of  $T_R$ . Limited degradation from this "optimum" performance does not strongly affect opinion; and, as shown in Ref. 12, values of  $\phi_1$  as low as about  $50^\circ$  are still considered "satisfactory" (for  $T_R < 1$ ).

Additional data plotted in Fig. 15 are unfortunately not as clearly interpretable as to desirable characteristics although they again correlate with  $\phi_1$  rather than  $p_0$ . These data (symbols  $\diamond, \nabla$ ) are for hovering flight conditions and although characterized by  $L_{\delta_a} \delta_{a_{max}}$  it is doubtful that maximum deflections were ever utilized. Thus there is a strong suspicion that the pilot's opinions were here related to stick sensitivity,  $L_{\delta_a} (d\delta_a/d\delta_s)$ , rather than maximum roll power. The question of optimum sensitivity or gain, will be discussed later in Section VI.

Considering now the question of required maneuvers for combat aircraft, we take note of a number of studies of the roll-control aspects of tactical maneuvers employed with various weapon-delivery systems.<sup>28-30</sup> In particular, the Ref. 28 analyses of extreme interceptor combat situations show that:

- a. The range required to maneuver to a collision course at 2g decreases by a maximum of about 2 percent for increasing average roll rates greater than about  $20^\circ/\text{sec}$ . For roll rates greater than about  $60^\circ/\text{sec}$ , the maximum realizable reduction in range is about 0.5 percent.
- b. The "safe launch zone" with respect to target illumination and breakaway considerations for an average roll rate of  $25^\circ/\text{sec}$  is 94 percent of that for infinite roll rate.
- c. The area, within a 50 mile radius of the first target, susceptible to an immediate second attack (involving, first, breakaway, re-attack and, second, breakaway) with a maximum roll rate of  $25^\circ/\text{sec}$  is about 88 percent of that for  $90^\circ/\text{sec}$  which is about 94 percent of that for infinite roll rate.
- d. For ground support maneuvers, average roll rates greater than  $40^\circ/\text{sec}$  offer little improvement in target coverage.

Only when a number of successive rolling maneuvers are involved, as in the Item c second-attack situation, does increasing roll performance begin to show a significant improvement. However, even for this

# Contrails

extreme case roll rates greater than about  $90^\circ/\text{sec}$  are unwarranted. The remaining situations require no more than about  $40^\circ/\text{sec}$ .

Reference 28 also considers the effect of roll performance on high speed ( $M = 0.9$ ) obstacle or collision avoidance through lateral displacement only. The results show that the roll rate beyond which there is a small and diminishing improvement increases with load factor. For example, an obstacle only 15 percent narrower than that clearable at an average roll rate of  $140^\circ/\text{sec}$  (the maximum investigated) and load factors of 2, 3, and 4 can be cleared by the drastically reduced average roll rates shown below:

| Obstacle distance<br>down-range | Range (deg/sec) required to clear 85 percent<br>of the width clearable at $140^\circ/\text{sec}$ |       |       |
|---------------------------------|--|-------|-------|
|                                 | n = 2  | n = 3 | n = 4 |
| 2000 ft                         | 75   | 80    | 100   |
| 4000 ft                         | 60   | 70    | 80    |
| 8000 ft                         | 40   | 60    | 70    |

Considerations of this kind have led to the suggestion that maximum available roll rate should increase with available load factor; but the trend noted here is not present in the combat maneuvers discussed above. Also, confining the obstacle clearance maneuver to the horizontal plane seems unrealistically restrictive.

Reference 30, which is a combined analytical and flight-test evaluation of tail-chase, shows that the roll performance required to follow the most extreme target maneuver considered ( $180^\circ$  in 1.4 sec,  $\Delta n = 4g$  in 1 sec, range/speed = 1 sec) is  $p_0 = 150^\circ/\text{sec}$  and  $L\delta_a \delta_{a_{\max}} = 5 \text{ rad}/\text{sec}^2$ . These figures convert to  $T_R = 0.524$  and, using Fig. 15, to  $\phi_1 = 1.25 \text{ rad} = 72^\circ$ . The permissible reduction in rolling performance of the chasing airplane (relative to the target) is due to the effective lead time given by range/speed. That is, the attacker must turn at the same point in space as his quarry; but he can do this range/speed seconds later. Only at very low values of range/speed will differences in roll performance have an important effect on the attacker's ability to prosecute, or the target's ability to evade, an attack. For modern fire-control systems with fairly large effective ranges, roll performance does not appear critical in tail-chase attacks.

# Contrails

Reference 29, a study of the effects of the limits (heading and range) from which a successful collision-course interception can be mounted, concludes only that roll performance is of little consequence compared to normal acceleration capability—a general conclusion of all the studies examined.

So far it seems that the "optimum"  $100^\circ$  in 1 sec found in Ref. 12 is somewhat more than is realistically required for combat situations or obstacle avoidance.

Landing Approach Considerations. Turning now to the question of roll performance for approach conditions, Ref. 24 contains flight-test assessments of full aileron effectiveness in raising a wing presumed thrown down  $30^\circ$  by a gust. The procedure was to apply full aileron (rudder-fixed) from a stabilized  $30^\circ$  bank in one direction to bank angles of  $0^\circ$  and  $30^\circ$  in the opposite direction and rate performance according to the following rating scale:

- a. Satisfactory — Sufficient response to pick up a wing with control to spare.
- b. Marginal — Barely enough response to pick up a wing with no control to spare.
- c. Unsatisfactory — Insufficient response to pick up a wing consistently to assure a safe landing.
- d. Unacceptable — Response so low as to be considered unsafe.

The resulting conditions of marginal performance (between b and c) were shown to correlate best with the bank angle change at 1 sec ( $\phi_1$ ); other parameters considered were peak roll rate, bank angle change at peak roll rate, and roll rate at 1 sec. The suggested criterion values are bank angle changes of  $20^\circ$  in 1 sec for small high-performance and all carrier-based airplanes and  $8^\circ$  in 1 sec for (large or slow) land-based airplanes. Unfortunately these numbers tell us little about the maneuver capability desired during landing approach, but rather are directly indicative of piloting desires as regards recovery from gust upsets (Item 3). Further, there is some question as to whether the pilot's

# Contrails

desires are properly represented by a minimum bank angle in 1 sec or perhaps more appropriately by a recovery time (i.e., time to return to zero bank). Figure 16 compares the bank angle in 1 sec data of Ref. 24 with the time to bank  $30^\circ$  (simulated recovery time) as extrapolated from the complete data of Ref. 24. It can be seen that a time to bank  $30^\circ$ ,  $t_{30^\circ}$ , of about 1.35 sec is just as representative of pilot desires as a bank angle of  $20^\circ$  in 1 sec.

The conceptual difficulty with a gust-recovery requirement based on bank angle in 1 sec is that it does not allow for differences in the gust response characteristics of various airplanes. For example, the time required for a given gust input to upset a variety of airplanes  $30^\circ$  will surely vary with inertia, roll damping, etc. Thus on the slower-responding airplanes we would expect the pilot to initiate recovery action before the upset had reached  $30^\circ$ . Under these circumstances why should he require as much bank angle response in 1 sec? On the other hand it was shown earlier (Fig. 4) that recovery time for gust inputs consistent with the upsets simulated in Ref. 24 is essentially independent of the time or bank angle at which recovery is initiated. To illustrate the effect on roll-power requirements of these two criteria forms, consider a nominal "good" value of  $T_R \doteq 0.5$ , a gust upsetting impulse of say,  $P_g = 64^\circ/\text{sec}$  and a full aileron bank angle response in 1 sec,  $\phi_1$ , of  $20^\circ$ ; for the latter the corresponding value of  $p_0$  (from Fig. 2 for  $t/T_R = 2$ ) is  $35^\circ/\text{sec}$ . Then, from Fig. 4, for initiation times,  $t_1$ , of 0.5 and 1 sec the corresponding recovery times,  $t_R$ , are both 1.36 sec and the maximum bank angles are  $23.1^\circ$  and  $28^\circ$ , respectively. For this same basic airplane with a twofold increase in roll inertia, the value of  $T_R$  is doubled, the value of  $P_g$  is halved, and  $p_0$  is unaffected. Then the bank angle change in 1 sec due to a step aileron is reduced to  $12.9^\circ$  and the recovery time (for  $t_1 = 0.5$  sec) is increased to 1.60 sec. To make this higher inertia configuration hold the  $20^\circ$  in 1 sec criterion requires a 55 percent increase in roll power; to hold the recovery time constant at 1.36 sec requires a 24 percent increase.

We see therefore that the concept of recovery time is far less sensitive to changes in inertia than the notion of a bank angle change



# Contrails

in 1 sec. Flight experience tends to support this relative insensitivity of required roll power to inertia changes. For example Ref. 24, itself, points out that the gust response of large airplanes is less than small airplanes and suggests a lower required bank angle in 1 sec for such aircraft. Also, Ref. 22 allows a 40 percent reduction in full aileron rolling response for take-off and landing with external fuel tanks. Finally, conversations with manufacturers and government agencies indicate that there is little deterioration in pilot acceptance when external stores which roughly double the rolling inertia are added.

These observations support the notion that the proper specification of adequate roll control for gust upsets must consider the gust response of the aircraft. Presumably this can be accomplished by a variable requirement on bank angle in 1 sec. However, it appears to the writer that a more straightforward and perhaps more instructive approach is to require recovery from a design gust in a given time. Of course the time available for recovery depends on the approach speed and the space available for completing the landing. Thus we would expect allowable recovery times for carrier landing airplanes to be considerably shorter than those for land-based aircraft. In fact the few data shown in Ref. 24 for "land-based" aircraft do indicate that allowable bank angles in 1 sec are less, as already noted;  $8^{\circ}$  rather than the  $20^{\circ}$  shown for carrier landing aircraft. The main arguments used to support this lower figure\* are the observations that the Douglas C-133B and Boeing KC-135 which rolled  $4^{\circ}$  and  $6^{\circ}$  in 1 sec were rated "slow response" and "good," respectively. Also, the Piper Aztec was considered unsatisfactory at  $11^{\circ}$ .

The flight test data of Refs. 25 and 26 are consistent with the numbers quoted above for the bank angle responses of the two large airplanes and show recovery times (from  $30^{\circ}$  bank to  $0^{\circ}$ ) of 3.5 and 2.3 sec and maximum roll rates of  $12^{\circ}/\text{sec}$  and  $18^{\circ}/\text{sec}$ , respectively (see Table II to be discussed later). In view of these latter figures there is some question

---

\* Reference 59, received during the final editing of this report, shows that "for the larger gross weight aircraft values of approximately  $8^{\circ}$  bank angle after 1 sec for full control resulted in satisfactory response.

# Contrails

as to whether the ratings quoted in Ref. 24 were based on bank angle increment in a given time, recovery time or (most likely) maximum roll rate. Note that Ref. 31 contains the recommendation that minimum roll power for large airplanes be  $15^\circ/\text{sec}$ . This figure coincides exactly with that recommended in Ref. 10 as discussed in Section III in connection with the lateral sidestep maneuver. If in spite of this we give full credence to the notion of recovery time as being of sole importance in these findings we conclude that a time of about 3 sec is a probable maximum satisfactory value for large land-based aircraft. The recovery time corresponding to the  $8^\circ$  in 1 sec proposed in Ref. 24 and supported principally by the Piper Aztec (U-11a) data is about 2.1 sec. This reduced figure may be due to the "livelier" airplane (i.e., high gust response) involved or may, again, represent a minimum desirable level of steady roll-rate (about  $22^\circ/\text{sec}$ ). Finally in this connection note that the proposed minimum requirement for  $p = 15^\circ/\text{sec}$  in 1.5 sec of Ref. 27 converts to a recovery time of about 2.5 sec (for  $T_R$  between 0.5 and 1.5)

In summary it appears, as regards rolling power during landing approach, that there is a fundamental side-step maneuvering requirement for a steady roll rate greater than about  $15^\circ/\text{sec}$ . In addition, it appears necessary to recover from impulsive-type maximum gust upsets in less than about 3 sec\* for land-based airplanes or less than about 1.35 sec for carrier-landing aircraft. It is understood, of course, that the aileron power requirements for such recoveries will depend on individual values of airplane derivatives (e.g.,  $C_{l\beta}$ ) and the type of gusts considered.\*\*

**Roll Performance of "Current" Aircraft.** Table II is a compilation of the roll performance of recent USAF airplanes which gives some additional insight on the influence of mission and size on roll performance requirements. Such a compilation suffers because the variation of roll performance

---

\*As observed earlier, these figures should logically depend on distance available for recovery/approach speed but present data do not warrant such refinement.

\*\*Reference 7 contains faired data which show that maximum aileron rolling moment must exceed that due to a step side gust by at least 50 percent. It may also be pertinent to consider more complicated gust input forms, e.g., those associated with vortices shed from large airplanes.

# Contrails

over the entire flight regime cannot conveniently be shown. The values selected for Combat or Cruise are those considered by the writer to be most significant in the present context or specifically called out in the referenced reports. They usually correspond to average performance under typical operating conditions (in some cases a range in performance is indicated). The values selected for landing approach are those for the minimum speed tested in the PA configuration. Also, consistent with our attempt to consider pure roll performance disassociated from unfavorable yawing effects, rudder-coordinated data were used where available. The pilot comments are not necessarily specifically related to the isolated performance shown, but generally reflect his over-all impression. Exceptions are those airplanes whose roll performance in the approach condition was separately commented on. Also, the comments do not necessarily have a common basis in terms of the adjectives used; and the differences between "satisfactory" and "adequate" or "good" and "excellent" may be nonexistent. Finally, in some cases the data plots were used to estimate values of  $\phi_1$ ,  $\phi_2$  (bank angle in 2 sec), and  $t_{300}$ , and there appear to be slight discrepancies in some of the values so obtained. These may in fact be real differences due to the varying rapidity with which full aileron was applied, in turn perhaps due to differences in control system response. (Time histories, in general available for the approach conditions, were used to identify the point at which aileron maneuvering force was applied. For cases not documented with time histories, a suitable effective time delay was used.)

Taking Table II at face value, it appears that:

1. For Fighter Airplanes

a. In combat conditions

- (1) Bank angles in 1 sec,  $\phi_1$ , greater than about  $60^\circ$  are considered satisfactory.
- (2) Bank angles in 1 sec,  $\phi_1$ , less than about  $45^\circ$  are considered unsatisfactory.
- (3) Steady roll-rate,  $p_0$ , is a poor metric of desirable performance (e.g., compare F-100C with F102A).

# Contrails

- b. All airplanes tested had satisfactory roll performance in approach. The maximum value of  $t_{300}$  recorded was 1.3 sec, the minimum  $p_0$  was  $50^\circ/\text{sec}$ .
2. For Heavy Bombers or Transports
    - a. In cruise conditions
      - (1) Bank angle in 1 sec does not correlate too well with evaluation comments. For example, the differences between "adequate", "satisfactory" and "very good" are not apparent in this parameter.
      - (2) Time to bank  $30^\circ$  ( $t_{300}$ ) is somewhat better as a correlating parameter but does not appear to be quite as good as the bank angle obtainable in 2 sec.
      - (3) A "good" value for bank angle in 2 sec,  $\phi_2$ , for no external loadings appears to be about  $30^\circ$ .
    - b. In approach conditions
      - (1) Bank angle in 1 sec is not of sufficient sensitivity to account for the different pilot comments.
      - (2) Time to bank  $30^\circ$ ,  $t_{300}$ , of about 3.5 sec seems to be the maximum acceptable, with values below about 3 considered satisfactory. These values can apparently increase for high roll-inertia conditions as indicated by the RB-52C data.
      - (3) Minimum acceptable roll-rates can apparently be as low as about  $12^\circ/\text{sec}$ .
3. For Intermediate Airplane Types
    - a. In cruise conditions "satisfactory" values of  $\phi_1$  steadily diminish in going from light trainers (T-37A through T-39) to small utility transports (MAC-119A) to medium bombers (B-66B) or fighter-bombers (F-105B).
    - b. In approach conditions the data are too sparse to show trends but it appears that values of  $t_{300}$  intermediate to those for fighters and heavy bombers are permissible. For example, the B-66B with  $p_0$  and  $\phi_1$  almost identical to the F-101A, but with a  $t_{300}$  of 1.7, is rated excellent, whereas the F-101A with a  $t_{300}$  of 1.3 is rated satisfactory.

# Conclusions

These observations on specific aircraft types are not inconsistent with the general notions developed earlier; e.g., the Ref. 12 result that for fighter airplanes,  $\phi_1$ 's greater than about  $50^\circ$  are satisfactory; the Ref. 28 result that roll rates greater than about  $90^\circ/\text{sec}$  are not required for fighter tactics, and values greater than about  $40^\circ/\text{sec}$  are not needed for ground attack; the suggested requirement that gust-upset recovery times for large land-based aircraft in approach be less than about 3 sec, but steady roll rate be at least  $15^\circ/\text{sec}$ .

Unfortunately the amount of evidence to support the latter approach performance minimums for smaller land-based craft is quite limited. It consists primarily of comparisons of the  $t_{30^\circ}$  values and the associated comments for the B-66B with those of the KC-135A and the C-133B. These show a quite consistent trend despite disparities in size and weight. That is, the comments "excellent," "good," and "minimum acceptable" are consistent with the corresponding values of  $t_{30^\circ}$  which progress from 1.7 to 2.3 to 3.5 sec. Also, two of the intermediate airplanes (T-39 and SA-16B) with roll rates of  $25^\circ/\text{sec}$  and  $20^\circ/\text{sec}$  were still considered satisfactory. For the remaining small airplanes including fighters there is insufficient spread in either comment or performance to be indicative of minimum requirements. However the RB-52C data by showing larger satisfactory values of  $t_{30^\circ}$  for high roll inertias, tend to support the idea that recovery time from a gust-induced upset rather than  $t_{30^\circ}$  (or  $\phi_1$ ) is an appropriate parameter for judging landing approach roll performance.

The data of Table II are considerably augmented by the corresponding collection given in Fig. 3 of Ref. 58 received, as noted earlier, during final editing of this report. In the referenced study, pilot assessments of twenty-one large aircraft of recent vintage (including some already in Table II), nineteen with spans between 89 and 142 ft, two with spans of about 180 ft, and with most having spans between 105 and 125 ft, are assembled to identify the boundary between satisfactory and marginal roll performance in approach. The boundary is shown to correspond to a bank and stop performance capability of  $60^\circ$  in 6.5 sec where the assumed aileron input involves ramp times from zero to full deflection of half a second. However, the boundary can also be used to compute values of  $p_e$ ,

# Contrails

$\phi_1$ ,  $\phi_2$  and  $t_{30^\circ}$  as presented in the following tabulation which assumes, consistent with Ref. 58, a 0.5 sec time interval to deflect the ailerons. It can readily be appreciated that these data lend considerable support to the general conclusions regarding acceptable approach

| REFERENCE 58<br>BOUNDARY COORDINATES |       | COMPUTED PERFORMANCE |          |          |                |
|--------------------------------------|-------|----------------------|----------|----------|----------------|
| $L\delta_a \delta_{a_{max}}$         | $T_R$ | $p_0$                | $\phi_1$ | $\phi_2$ | $t_{30^\circ}$ |
| 0.5                                  | 0.385 | 11.1°/sec            | 4.59°    | 15.1°    | 3.35 sec       |
| 0.4                                  | 0.5   | 11.5°/sec            | 4.13°    | 14.5°    | 3.36 sec       |
| 0.3                                  | 0.7   | 12.0°/sec            | 3.55°    | 13.2°    | 3.45 sec       |
| 0.2                                  | 1.26  | 14.4°/sec            | 2.75°    | 11.7°    | 3.48 sec       |

roll performance expressed above and arrived at without their benefit. The use of bank and stop maneuvers<sup>58</sup> rather than the simpler and more easily flight-test-produced  $t_{30^\circ}$  seems to have been prompted by the consideration that a minimum of three such maneuvers are required to accomplish the "sideslip." This notion is implicitly rejected by the (speculative) analysis presented in Section III-B and also seems inconsistent with the observed minimum sidestep maneuver times of 10 sec noted in Ref. 10 (i.e., three bank and stop maneuvers, each of 6.5 sec duration, would give a minimum acceptable sidestep maneuver time of about 20 sec).

Coming back to the Table II data, a final observation is that the roll performance of large aircraft in cruise is poorly measured by conditions one second after aileron application because of large inherent lags. Bank angle in two or more seconds is more consistently determined with usual flight test procedures.\* A minimum value of  $\phi_2$  of the order of 25° to 30° for "normal" airplane loadings seems indicated.

\*Flight procedure for accurately determining full aileron roll acceleration at zero roll rate, recommended in Ref. 59, is not directly indicative of the actual conditions (including control response characteristics) affecting pilot rating.

## SECTION VI

### "OPTIMUM" GAIN CONSIDERATIONS

For control situations where maximum effectiveness is not required, pilots' ratings are, for a given value of  $T_R$ , strongly influenced by the gradient or gain,  $L_{\delta_a}$ , as noted earlier. It has been postulated (e.g., Refs. 5, 33) that such influences are best "explained" in terms of the pilots' gain required for closed-loop operation rather than in terms of the vehicle gain. This seems rather a fine point in view of the apparent inverse relationship between  $Y_p$  and  $Y_c$ , but if nothing else it serves to remind us that "desirable" levels of gain do depend on the pilots' adaptation and the muscles and senses involved in exercising control. A bigger question concerns the selection of the gain, most representative over the pertinent frequency range, of his desires. In this connection we postulate further that pilot gain in the crossover region is his chief concern. Let's examine the resulting implications in light of the available data.

At crossover we have, by definition (see Eq 5)

$$|Y_p(\omega_c)Y_c(\omega_c)| = 1$$

whereby

$$|Y_p(\omega_c)| = \frac{1}{|Y_c(\omega_c)|} = \frac{\omega_c \sqrt{T_R^2 \omega_c^2 + 1}}{L_{\delta_a} T_R} \quad (28)$$

The expression on the right is the inverse of the absolute value of  $\phi/\delta_a(\omega_c)$  from Eq 1. If we consider  $\omega_c$  to be roughly constant at 2.5 rad/sec, the resulting values of  $|L_{\delta_a} T_R Y_p(\omega_c)|$  depend only on  $T_R$  as shown by the heavy reference line of Fig. 17; and, if the "best" opinion  $|Y_p(\omega_c)|$  is constant, the corresponding best values of  $L_{\delta_a} T_R$  will be parallel to this line. The broken-line asymptotes show that for  $\omega_c T_R < 1$  the controlled-element gain of most importance to the pilot is  $L_{\delta_a} T_R$ , the roll-rate gain; for  $\omega_c T_R > 1$  it is  $L_{\delta_a}$ , the acceleration gain. The differences between the complete

# Contrails

curve and its asymptotes are well within the usual uncertainties and tolerances associated with "optimum" gain. Nevertheless, the data points shown lie fairly close to the dashed lines drawn parallel to the complete reference curve.

The circled points, taken from Ref. 56, are for a center-stick (2 lb/in.), single-axis tracking task in the presence of a random-appearing forcing function composed of four equal amplitude input sinusoids (frequencies at 0.09, 0.30, 0.64, and 1.15 rad/sec) with an rms input of 15° in bank. The remaining points are those for the VTOL configurations plotted on Fig. 15 which, as noted earlier, were suspected to be more influenced by gain than by maximum effectiveness. Interestingly enough these latter points are fitted equally well by either the relationship in Fig. 17 or the bank angle in 1 sec line of Fig. 15. This implies that an alternative, albeit not clearly related measure of desirable gain, may be in terms of the bank angle response in a given time, e.g., 1 sec. This result also follows from the asymptotic behavior noted in Fig. 17 and the similar behavior of Eq 7. That is, for low values of  $T_R$  the controlled element is primarily a rate control so either gain or bank angle response in a given time is proportional to the rate gain,  $L_{\delta_a} T_R$ . Conversely for high values of  $T_R$ , control motions produce accelerations so that response or gain is proportional to  $L_{\delta_a}$ .

For low values of  $T_R$  there are some additional data relating to optimum gains which can be compared with the data plotted in Fig. 17, as follows:

| Ref.   | $T_R$ | Optimum Gain, $L_{\delta_a} T_R$<br>rad/sec/in. | $L_{\delta_a} T_R \frac{\partial \delta_a}{\partial F}$<br>rad/sec/lb |
|--------|-------|---|---|
| 13     | 0.35  | 0.36  | 0.18  |
| 14     | 0.40  | 0.66  | 0.33  |
| 15, 16 | 0.40  | 1.10/5 in.* = 0.22                              | ?   |
| 56     | 0.40  | 1.5   | 0.75  |

\* Assumes 5 in. of total linear stick travel



# Conclusions

About the only point emerging from this comparison is the observation that the flight test values (Refs. 13-15) of desirable gain are considerably less than the fixed simulator (Refs. 14, 56) values. This may be due to the additional degrees of freedom involved in flight versus the single degree of freedom simulated. Presumably with additional axes to control the pilot may want reduced sensitivity about the roll axis. In any event the lateral gradients would have to be in "harmony" with the other axes to be considered desirable.

The factor of 2 or so variation in best gain for either simulator or flight test is not too surprising in view of the fairly flat optimum region characteristic of gain effects. As shown in Refs. 5 and 33, such spreads are to be expected within about one-half rating point of the faired optimum and this is about as good repeatability in delivering ratings as can be expected from qualified test pilots.

In summary:

1. "Optimum" gain variations with  $T_R$  are directly explainable in terms of closed-loop considerations and a desired pilot gain at crossover.
2. The general correlation of pilot ratings with bank angle in a given time is consistent with optimum gain considerations which "explain" the pilot's apparent preference for this particular open-loop metric.
3. The magnitude of the optimum gain appears to depend on the additional axes of control and their gradients.

As a final note the question of whether roll gain should be measured in terms of stick displacement or force remains unanswered by any of the data examined. It is the author's feeling, based on the observation that spring centered sticks are suitable for flight over large speed ranges (also noted in Ref. 58), that force gradients are relatively unimportant provided they are comfortable and provide desirable stick centering.

# Conclusions

## SECTION VII

### CONCLUSIONS

The foregoing analyses, data, and related discussions lead to the following conclusions:

1. Values of  $T_R$  less than about 0.5 to 1.0 will not improve the pilot's rating of an airplane's roll response and controllability.
2. Values below this range may be helpful in whatever reduction they afford of  $|\phi/\beta|$ -related effects; however such effects are amenable to a variety of corrective measures<sup>1</sup> other than reduced  $T_R$ .
3. The maximum value of  $T_R$  considered satisfactory is about 1.3 to 1.5; and there is no strong evidence in existing data or theory for allowing this value to increase with airplane size or mission. As a matter of fact, the speculations concerning the open-loop aspects of the sidestep maneuver (Section III-B) indicate that decreased maximum values of  $T_R$  may be required for airplanes with limited available maneuver time due to either, or combinations of, increased approach speed, lower minimum ceilings, and shorter runway lengths (considering present-day ILS localizer errors).
4. For a given value of  $T_R$  there is an "optimum" gain or sensitivity,  $L_{\delta_a}$ , and the experimental variation of the optimum with  $T_R$  is consistent with both closed-loop and open-loop "explanations."
5. The experimentally observed values of the "optimum" gain vary considerably, probably due to differences in manipulators, additional control axes, etc. However, the optimum region is quite broad and attaining this region does not seem to present more than a minor design problem.
6. Aileron power,  $L_{\delta_a} \delta_{a_{max}}$ , must in general be sufficient to
  - (a) balance the airplane under all conditions of aerodynamic, inertial, or power-plant asymmetries, (b) maintain attitude in steady side winds or deliberate sideslips, (c) maintain or quickly recover

# Conclusions

attitude in gusty air, (d) permit rapid recovery from spins, (e) permit crosswind landings and takeoffs, and (f) perform required maneuvers consistent with the airplane's effective utilization. In normal practice Items c and e above, while not always critical, are usually the most difficult to assess and the following conclusions relate to them specifically.

7. For combat and cruise conditions, the pilot opinion aspects of roll performance are most accurately and conveniently measured in terms of the bank angle achievable in a given time in response to an abrupt full aileron (stick) input.
8. For fighter airplanes in combat condition, bank angle in one second,  $\phi_1$ , greater than about  $50^\circ$  appears to be a reasonably well supported requirement from both the standpoint of pilot rating and usable maneuvering capability.
9. For heavy bombers or transports in cruise, bank angle in two seconds,  $\phi_2$ , greater than about  $25^\circ - 30^\circ$  for "normal" loadings seems to be indicated by the little data available (Table II).
10. For large airplanes on approach, the most accurate and convenient metric, generally descriptive of pilot desires, is the time required to roll through  $30^\circ$ ,  $t_{30^\circ}$ , following an abrupt maximum aileron (wheel or stick) input. The data available indicate that values of  $t_{30^\circ}$  greater than about 3 to 3.5 sec are unacceptable.
11. The above limiting value of  $t_{30^\circ}$  is more properly considered to be the maximum allowable recovery time,  $t_R$ , following a bank angle upset due to an impulsive gust encounter. That is, the time (or distance) required to oppose the actual upset and restore  $\phi \doteq 0^\circ$  conditions is critical. Thus, for example, airplanes with larger than "normal" values of dihedral,  $I_p^1$ , whereby they suffer greater upsets for a given gust, will presumably require lower values of  $t_{30^\circ}$ ; but the maximum acceptable value of the time to recover,  $t_R$ , may still be three to three and one-half seconds. Gust forms other than impulsive should in general also be considered in judging the acceptability of approach roll power, but for these the time at which recovery is initiated may be exceedingly

# Contrails

critical and it is doubtful that recovery time will be a generally valid criterion for all gust forms.\*

12. Large-airplane approach maneuvering requirements seem to demand minimum steady roll rates,  $p_0$ , greater than about  $12^\circ - 15^\circ/\text{sec}$ .
13. The foregoing large-airplane approach requirements seem applicable as well (in principle at least) to small and intermediate size land-based aircraft, although definitive data on this score are lacking. However, there are few small aircraft which do not exceed by a wide margin these minimum requirements.
14. For small and intermediate carrier-based aircraft, recovery from gust upsets on approach must be accomplished in considerably less time (distance) and the maximum acceptable value of  $t_R$  ( $t_{300}$ , as flight-tested) is reduced to about 1.3 sec.
15. For intermediate airplanes in cruise, satisfactory values of  $\phi_1$  steadily diminish in going from light trainers to small utility transports to medium bombers or fighter-bombers.
16. Fixed-base simulations, employing realistic gust input characteristics, displays, and properly briefed and experienced test pilots, are expected to give generally valid results on all the above aspects of roll handling qualities.

---

\*Reference 58 tentatively suggests "that under approach conditions a large aircraft will be classed as at least 'acceptable for normal operation' provided the bank following a 10 kt side gust can be limited to  $5^\circ$  by the use of not more than one-half aileron."

# Contracts

## REFERENCES

1. Ashkenas, I. L., A Study of Conventional Airplane Handling Qualities Requirements, Part II, Lateral-Directional Oscillatory Handling Qualities, AFFDL-TR-65-138, Part II, Oct. 1965.
2. McRuer, D., Graham, D., Krendel, E., and Reisener, W., Jr., Human Pilot Dynamics in Compensatory Systems—Theory, Models, and Experiments with Controlled Element and Forcing Function Variablenes, AFFDL-TR-65-15, May 1965.
3. McRuer, D. T., Ashkenas, I. L. and Guerre, C. L., A Systems Analysis of Longitudinal Flying Qualities, WADD-TR-60-43, Jan. 1960.
4. Stillwell, W. H. and Drake, H. M., Simulator Studies of Jet Reaction Controls for Use at High Altitude, NACA RM H58G18a, Sept. 1958.
5. Lollar, T. E., A Rationale for the Determination of Certain VTOL Handling Qualities Criteria, AGARD Report 471, 1963.
6. Cooper, G. E., "Understanding and Interpreting Pilot Opinion," Aeron. Eng. Rev., Vol. 16, No. 3, March 1957, pp. 47-52.
7. Pinsker, W. J. G., Features of Large Transport Aircraft Affecting Control During Approach and Landing, AGARD Report 421, 1963.
8. Pinsker, W. J. G., Aileron Control of Small-Aspect-Ratio Aircraft; in Particular, Delta Aircraft, Aeronautical Research Council R and M 3188, October 1953.
9. Etkin, B., Dynamics of Flight, Stability and Control, John Wiley and Sons, Inc., New York, 1959.
10. Perry, D. H., Port, W. G. A. and Morrall, J. C., A Flight Study of the Sidestep Manoeuvre During Landing, Aeronautical Research Council, R and M 3347, July 1961.
11. Litchford, G. B., "The 100-ft Barrier," Astronautics and Aeronautics, Vol. 2, No. 7, July 1964.
12. Creer, B. Y., Stewart, J. D., Merrick, R. B. and Drinkwater, F. J. III, A Pilot Opinion Study of Lateral Control Requirements for Fighter-Type Aircraft, NASA Memo 1-29-59A, March 1959.
13. Harper, R. P., Jr., In-Flight Simulation of the Lateral-Directional Handling Qualities of Entry Vehicles, WADD-TR-61-147, Nov. 1961.
14. Durand, T. S. and Jex, H. R., Handling Qualities in Single-Loop Roll Tracking Tasks: Theory and Simulator Experiments, ASD-TDR-62-507, Nov. 1962.

# Contrails

15. Rolls, L. S. and Drinkwater, F. J., A Flight Determination of the Attitude Control Power and Damping Requirements for a Visual Hovering Task in the Variable Stability and Control X-14A Research Vehicle, NASA TN D-1328, May 1962.
16. Faye, A. E., Jr., Attitude Control Requirements for Hovering Control Through the Use of a Piloted Flight Simulator, NASA TN-D-792, April 1961.
17. Palmer, W. E., A Flight Simulator Study of the Lateral-Directional Stability Requirements of Piloted Air Vehicles, North American Aviation, Inc., NA 61H-241, March 1961.
18. Garren, J. F. Jr., and Assadourian, A., VTOL Height-Control Requirements in Hovering as Determined from Motion Simulator Study, NASA TN D-1488, Oct. 1962.
19. A'Harrach, R. C. and Kwiatkowski, S. F., "A New Look at V/STOL Flying Qualities," Aerospace Eng., Vol. 20., No. 7, July 1961.
20. Gerdes, R. M. and Weick, R. F., A Preliminary Piloted Simulator and Flight Study of Height Control Requirements for VTOL Aircraft, NASA TN D-1201, Feb. 1962.
21. Wolkovitch, J. and Walton, R. P., VTOL and Helicopter Approximate Transfer Functions and Closed-Loop Handling Qualities, Systems Technology, Inc., TR-128-1, Jan. 1965.
22. Mazza, C. J., Cohen, M., Becker, W. and Spector, A., Proposal for a Revised Military Specification, "Flying Qualities of Piloted Airplanes" (MIL F-8785ASG), with Substantiating Text, NADC ED 6282, Jan. 1963.
23. McLaughlin, M. D. and Whitten, J. B., Pilot Evaluation of Dynamic Stability Characteristics of a Supersonic Transport in Cruising Flight Using a Fixed-Base Simulator, NASA TN D-2436, Sept. 1964.
24. Patterson, G. A. and Spangenberg, W., The Provision of Adequate Lateral Control Power for Landing Approach Conditions, AGARD Rept. 419, Jan. 1963.
25. Burke, K. D., and Benefield, T. D., C-133B Category 1 Stability and Control Tests, AFFTC-TR-60-3, April 1960.
26. Crawford, C. C. and Seigler, J. P., KC-135A Stability and Control Test, AFFTC-TR-58-13, May 1958.
27. Flying Qualities and Control Characteristics of Civil Transport Aircraft, SAE Proposal ARP842, Jan. 1964.
28. Kelley, H. J., and Aubin, W. M., Mission Analysis to Determine Roll Performance Requirements, Grumman Aircraft Engineering Corp., Research Rept. RE-125, March 1960.

# Contrails

29. Phillips, W. H., Analysis of Effects of Interceptor Roll Performance and Maneuverability on Success of Collision-Course Attacks, NASA TN-D-952, Aug. 1961.
30. Adams, J. J., Flight and Analytical Study of Roll Requirements of a Fighter Airplane, NACA-RM-L56F12a, Aug. 1956.
31. Seigler, J., and Capasso, V., C-133A Phase II Flight Evaluation, AFFTC-TR-56-40, Feb. 1957.
32. Seckel, E., Hall, I.A.M., McRuer, D. T., and Weir, D. H., Human Pilot Dynamic Response in Flight and Simulator, WADC-TR-57-520, Oct. 1957.
33. Ashkenas, I. L., and McRuer, D. T., The Determination of Lateral Handling Qualities Requirements from Airframe-Human Pilot Systems Studies, WADC-TR-59-135, June 1959.
34. Stoliker, F. N. and Boyd, L., Phase II Flight Tests of the YB-60 Airplane, AFFTC-TR-53-10, April 1953.
35. Stoliker, F. N., and V. C. Givens, Phase II Performance and Stability and Control Tests of the XF-104, USAF No. 53-7786, AFFTC-TR-55-8, May 1955.
36. Kirkeberg, Knute, Jr., and Schalk, Louis W., F-86H Phase IV Performance Stability and Control, AFFTC-TR-56-2, Feb. 1956.
37. Capasso, V. N. and L. W. Schalk, F-101A Limited Phase IV Stability with External Stores, AFFTC-TR-56-14, August 1956.
38. Leisy, D. C. and M. G. Apt, Evaluation of the Standard F-100C Pitch Damper and the XV-A Longitudinal Control System, AFFTC-TR-56-25, November 1956.
39. Frazier, Frank D., and Fulton, Fitzhugh L., RB-52C Limited Phase IV Performance and Stability, AFFTC-TR-56-32, Dec. 1956.
40. Archer, D. D. and C. L. Gandy, Jr., T-37A Phase IV Performance and Stability and Control, AFFTC-TR-56-37, February 1957.
41. Allender, J. R. and R. M. White, F-102A Phase IV Stability Test, AFFTC-TR-57-5, April 1957.
42. Crawford, Charles C., and Benefield, Tommie D., SA-16B Limited Phase IV Stability Control and Performance, AFFTC-TR-57-16, Oct. 1957.
43. Reed, Jerome B., and Carlson, John M., B-66B Phase IV Stability and Limited Performance Test, AFFTC-TR-57-19, Sept. 1957.
44. Archer, Donald D., and Benefield, Tommie D., C-133A Phase IV Stability and Control, AFFTC-TR-57-34, Jan. 1958.

# Contrails

45. Simmons, C. D. and Sorlie, D. M., F-101B Air Force Stability and Control Evaluation, AFFTC-TR-58-11, May 1958
46. Yancy, M. H., Jr., and Benefield, T. D., Model NA-246 (T-39) Air Force Flight Evaluation, AFFTC-TR-59-10, March 1959
47. Lusby, W. A. and Benefield, T. D., C-130B Category I Stability and Control Tests, AFFTC-TR-59-17, June 1959
48. Johnson, Charles O., and Cole, Frank E., McDonnell Model 119A Air Force Evaluation, AFFTC-TR-59-25, Sept. 1959.
49. Kates, Clarke M., and Titus, Robert F., F-105B Category II Stability and Control Tests, AFFTC-TR-59-29, Oct. 1959.
50. Schweikhard, W. and Rushworth, R., F-104B Category II Performance and Stability Evaluation, AFFTC-TR-59-32, December 1959.
51. McNamar, L. F. and Rushworth, R. A., F-106A Category II Performance, Stability and Control Tests, AFFTC-TR-60-14, November 1960.
52. Johns, S. L. and Campbell, J. K., YAC-1DH Category II Performance and Stability Tests, AFFTC-TR-60-41, November 1960
53. Lusby, W. A. and Hanks, N. J., T-38A Category II Stability and Control Tests, AFFTC-TR-61-15, August 1961
54. Yancy, Marion H., Jr., and Stephens, Robert L., Roll Evaluation of the F-102A with an Enlarged Vertical Stabilizer, AFFTC-TN-56-15, Apr. 1956.
55. Allen, Willie, L., and White, Robert M., An Evaluation of the Side Stick Control System Installed in the F-102A, AFFTC-TN-56-24, Nov. 1956.
56. McDonnell, J. D., Preliminary Experimental Investigation of a New Pilot Rating Scale and Pilot Parameter Tracker, Systems Technology, Inc., WP-134-9, July 1964.
57. White, M. D., Vomaske, R. F., McNeill, W. E., and Cooper, G. E., A Preliminary Study of Handling Qualities Requirements of Supersonic Transports in High-Speed Cruising Flight Using Piloted Simulators, NASA TN D-1888, May 1963.
58. Bisgood, P. L., A Review of Recent Handling Qualities Research, and Its Application to the Handling Problems of Large Aircraft, Royal Aircraft Establishment TN Aero 2688, June 1964.
59. Anderson, S. B., Quigley, H. C., and Innes, R. C., Stability and Control Considerations for STOL Aircraft, Paper presented to AGARD Flight Mechanics Panel, Paris, June 1965.



TABLE I. DATA SOURCES FOR  $K_C/s(T_{CS} + 1)$  HANDLING QUALITIES

| REF. NO. | REPORT NO          | TYPE OF SIMULATION |             | INPUT  | TASK  | REMARKS  |
|----------|--------------------|--------------------|-------------|--|---|--|
|          |                    | Fixed Base         | Moving Base |  |   |  |
| 12       | NASA Memo 1-29-59A | ✓                  | ✓           | None   | Rapid rolls to $\phi < 270^\circ$ .<br>Precise $\Delta\phi$ change.<br>Roll axis only.  | Basic roll control reference; good correlation with limited flight tests is also shown.  |
| 13       | WADD-TR-61-147     |                    | ✓           | Simulated random gusts                           | (1) Straight flight — small turns.<br>(2) $\Delta\psi > 90^\circ$ , $30^\circ < \phi < 60^\circ$ .<br>(3) Slow and rapid rolls to $180^\circ$ and $360^\circ$ .<br>(4) (1) and (2) + simulated gusts. | Primarily concerned with $\omega_{\phi}/\omega_{\theta}$ effects, but limited roll damping. Control power data available.                          |
| 14       | ASD-TDR-62-507     | ✓                  |             | Random $\phi$ disturbances                       | Track $\phi$ — roll axis only.  | Primarily concerned with $\omega_{\phi}/\omega_{\theta}$ effects, but limited roll damping data available. <u>NO</u> control power data available. |
| 15       | NASA TN D-1328     |                    | ✓           | Natural wind < 10 kt                             | Hovering turns, sideways flight, forward and rearward "quick stops," vertical takeoff and landings.   | Modes <u>not</u> under evaluation. Well damped.  |
| 16       | NASA TN D-792      | ✓                  | ✓           | ?  | Hovering roll control plus other axes.  | Used for isolated flight data points which were included for comparison with simulation — latter data incomplete.                                  |
| 17       | NAA NA61H-241      | ✓                  |             | None except (4)                                  | (1) Standard rate turns, $\phi = 30^\circ$ .<br>(2) Rapid rolls to $60^\circ < \phi < 90^\circ$ .<br>(3) Rudder kicks.<br>(4) Lateral step gust.  | All axes, longitudinal characteristics "good."   |
| 18       | NASA TN D-1488     |                    | ✓           | None   | $\Delta h$ rapidly and with minimum overshoot; single axis.   |  |
| 19       | IAS Paper 61-62    | ✓                  |             | Simulated random gusts                           | Three-axis hovering and transition flight.  | Modes not under evaluation. Well damped.   |
| 20       | NASA TN D-1201     | ✓                  | ✓           | None for simulation, natural wind for flt. test. | $\Delta h$ as in Ref. 18.   | Some flt. test points not at optimum gain; basic simulator gain variations not too apparent but can get some indication from ground effect tests.  |
| 5        | AGARD Rept. 471    | ✓                  |             | Simulated random gusts                           | Hold pitch attitude.  | Pilot transfer functions measured by a tracking model.   |
| 23       | NASA TN D-2436     | ✓                  |             | None   | Eliminate heading error while holding h and M.  | "Good" characteristics for modes not under investigation.  |
| 57       | NASA TN D-1888     |                    | ✓           | None   | Turn precisely,<br>control abrupt loss of one engine.   | All parameters not under investigation set at values giving pilot rating of 1.5.   |

TABLE II. FULL ALLERON ROLL PERFORMANCE OF USAF AIRPLANES

| REF. | AIRPLANE           | SPAN<br>(ft) | WING<br>VELOCITY<br>(1000 lb) | COMBAT OR CRUISE |                |                         | LANDING APPROACH |                       |                | EVALUATION COMMENTS  |
|------|--------------------|--------------|-------------------------------|------------------|----------------|-------------------------|------------------|-----------------------|----------------|--|
|      |                    |              |                               | P <sub>0</sub>   | φ <sub>1</sub> | φ <sub>2</sub>          | t <sub>30°</sub> | P <sub>0</sub>        | φ <sub>1</sub> |  |
| 36   | F-66H              | 39           | 23.8                          | 85               | 45             |                         |                  | 70                    |                | Unsatisfactory for combat, OK for approach                                       |
| 37   | F-100C             | 39           | 30.8                          | 150*             | 40*            |                         |                  | No data               |                | poor control response, large alleron yaw<br>Inadequate — for approach conditions |
| 37   | F-101A(1)          | 40           | 46.7                          |                  |                |                         |                  | 50                    | 1.6            | Satisfactory for approach  |
| 37   | F-101B             | 40           | 43.1                          | 180*             | 80*            | Maximum roll restricted |                  | 80                    | 1              | Satisfactory   |
| 38   | F-102A             | 38           | 28                            | 160 - 220        | 80 - 130       |                         |                  | 85                    |                | Good roll capability   |
| 38   | F-102A             | 38           | 28                            |                  | 100*           |                         |                  | P <sub>30°</sub> = 34 | 1.1            | Adequate   |
| 38   | F-102A(2)          | 38           | 28                            | 110 - 180        | 70*            |                         |                  | 70                    | 0.8            | 10° alleron limit acceptable for the flight conditions investigated              |
| 38   | XF-104             | 22           | 18.5                          | 250*             | 100*           |                         |                  | 80(3)                 | 30(3)          | Very satisfactory  |
| 39   | F-104B(4)          | 25           | 20.9                          | 100*             | 40*            |                         |                  | 80                    | 1.3            | Unsatisfactory for combat; satisfactory for approach                             |
| 39   | F-105B             | 35           | 49                            | 150              | 40 - 60        |                         |                  | 60                    |                | Adequate for fighter-bomber mission  |
| 39   | F-106A             | 38           | 35                            | 150              | 60             |                         |                  | No data               |                | Satisfactory   |
| 39   | YB-60              | 206          | 410                           | 8                |                |                         |                  | No data               |                | Very poor in general; marginal for landing approach                              |
| 39   | RB-52C             | 185          | 371, 440(5)                   | 25               | 5              | 25 - 17(5)              |                  | 11(5)                 | 4.1(5)         | Satisfactory   |
| 40   | C-130B             | 133          | 135                           | 20 - 30          | 10 - 13        | 30°                     |                  | 12                    | 2.9            | Satisfactory in general  |
| 40   | C-133A             | 180          | 255                           | 22 - 24          | 6 - 7          | 27°                     |                  | 14                    | 3.9            | Adequate   |
| 40   | C-133B             | 180          | 286                           |                  | Same as C-133A |                         |                  | 12                    | 3.5            | Control during approach considered minimum acceptable                            |
| 40   | KC-135A            | 151          | 300                           | 33               | 9              | 37°                     |                  | 18                    | 2.3            | Very good for cruise; good for approach  |
| 40   | T-37A              | 34           | 6.2                           | 125*             | 75*            |                         |                  | 40*                   |                | Ample roll capability in general   |
| 40   | T-38A              | 25           | 11.5                          | 150 - 190        | 70 - 140       |                         |                  | 75                    | 0.75           | Excellent  |
| 40   | NA-246 (T-39)      | 42           | 11.6                          | 90               | 65             |                         |                  | 25                    |                | Satisfactory in general  |
| 40   | MAC-119A           | 57           | 45                            | 70               | 44             |                         |                  | 34                    |                | Excellent  |
| 40   | B-66B              | 72           | 96                            | 60 - 70          | 25 - 30        |                         |                  | 47                    | 1.7            | Excellent throughout entire speed range  |
| 40   | SA-16B             | 97           | 34                            | 30               |                | No data                 |                  | 20                    |                | Satisfactory in general  |
| 40   | YAC-119K (Caribou) | 96           | 26                            |                  |                |                         |                  | 8                     |                | Unsatisfactory   |

(1) With external stores  
 (2) With enlarged fin and alleron limited to 10°  
 (3) Takeoff configuration  
 (4) With 20-inch tip tanks  
 (5) External tanks full

# Contrails

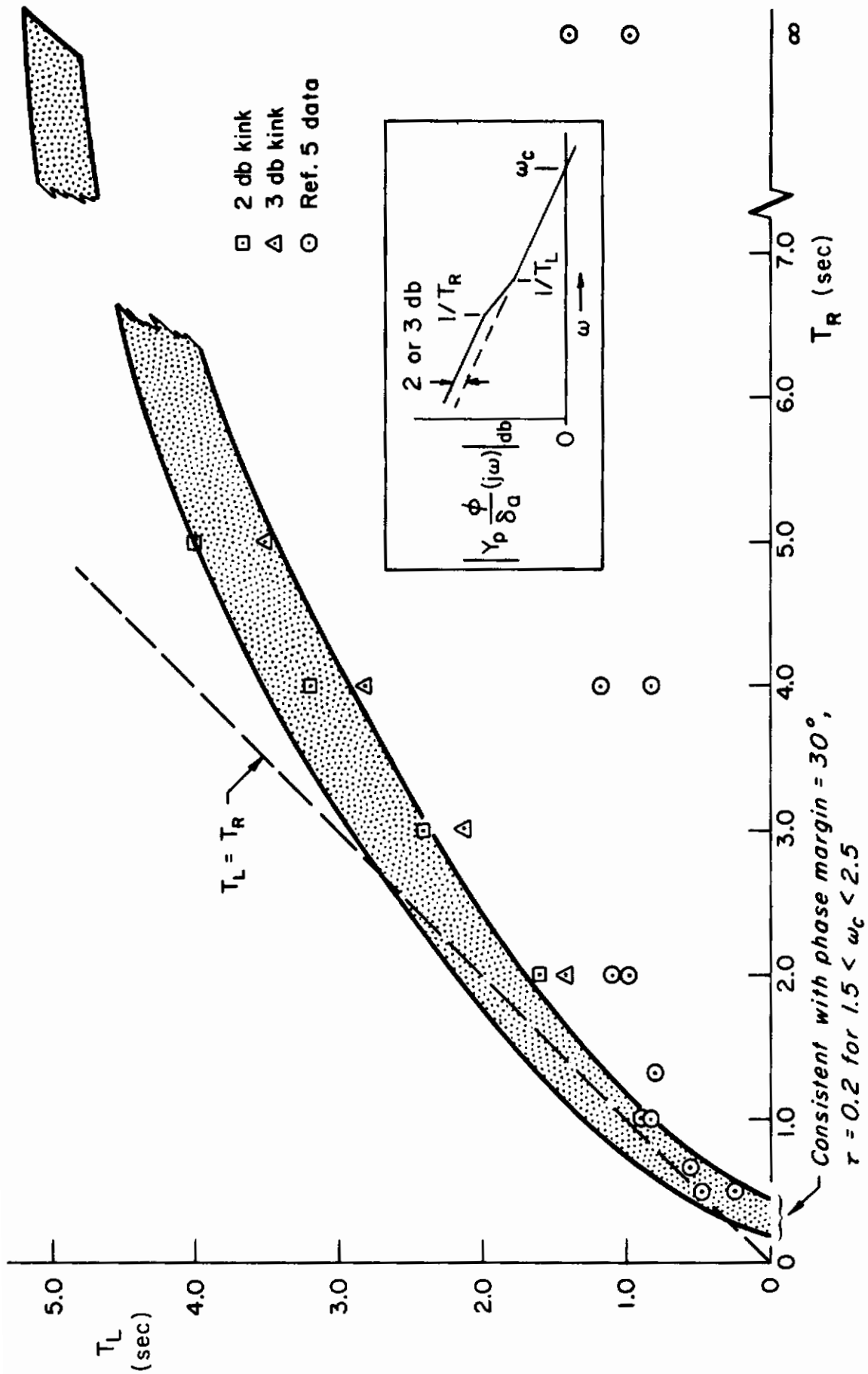

Figure 1. "Expected"  $T_L$  Versus  $T_R$  Relationship

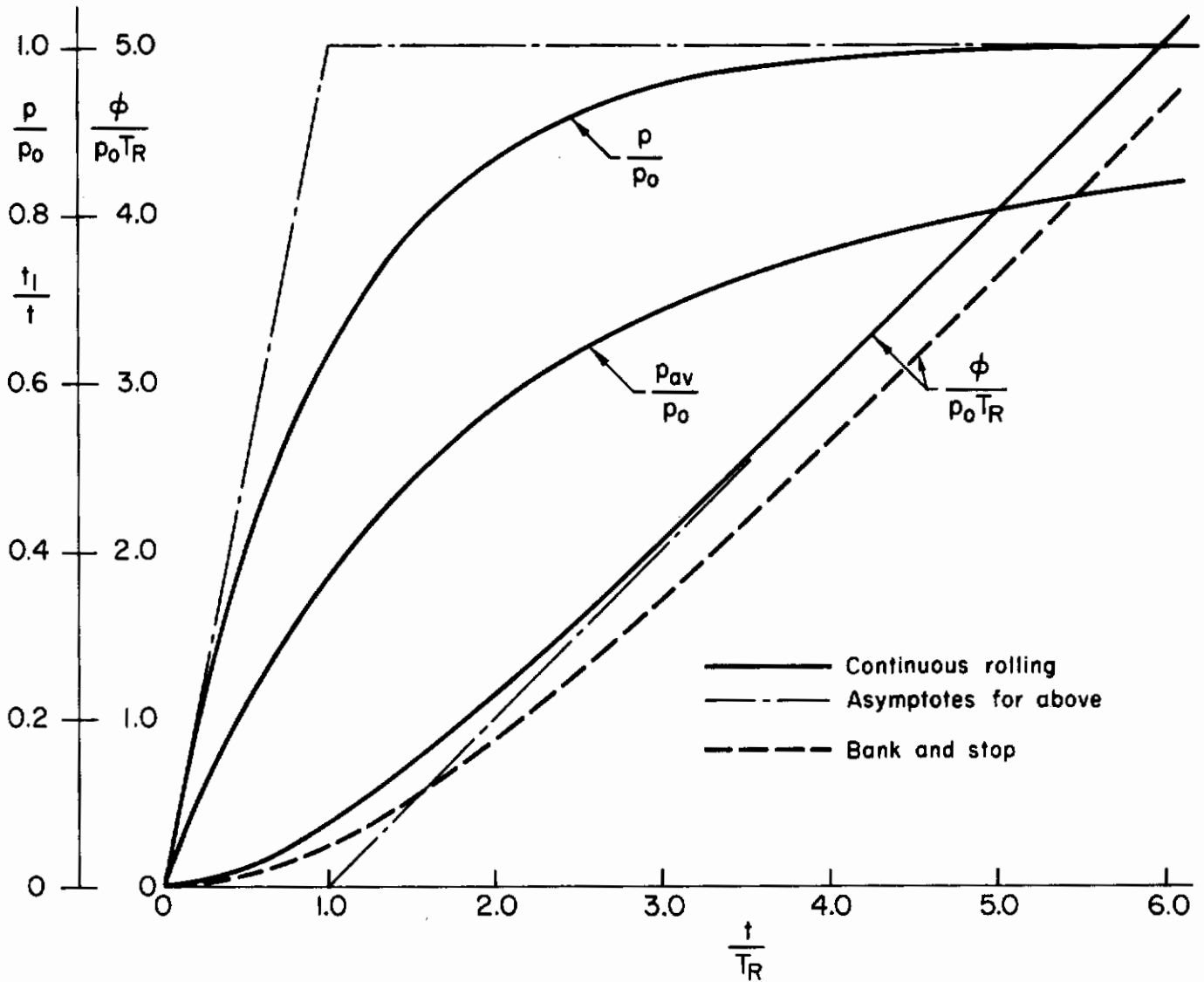

Figure 2. Roll Response to a Step Aileron

# Contrails

$\phi_{b \& s}$  Bank and stop roll angle

$\phi_{cont.}$  Continuous rolling bank angle

$p_1$  Rolling velocity at initiation of stopping maneuver

$\Delta\phi$  Bank angle increment required to stop

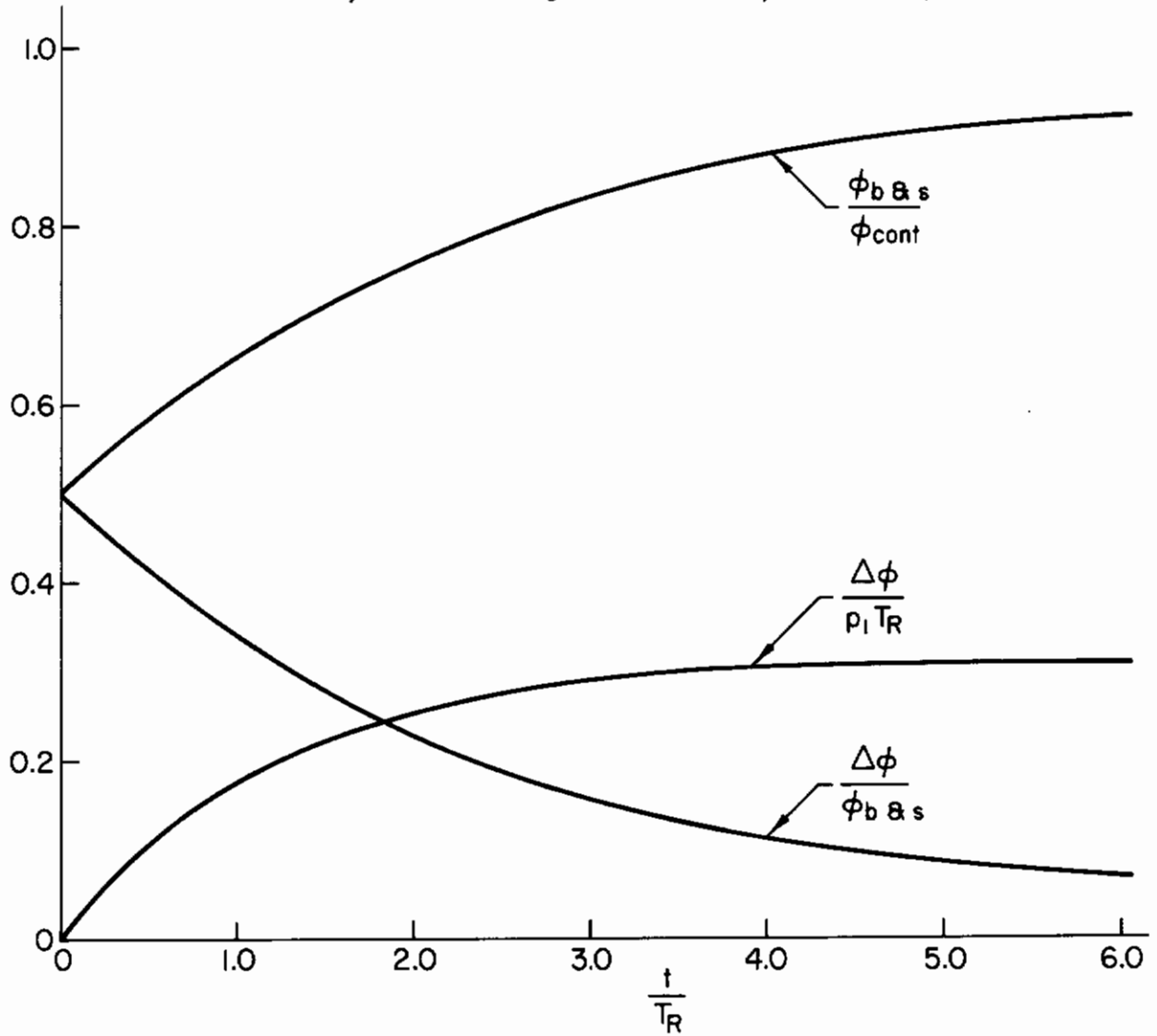

Figure 3. Maximum Performance Bank and Stop

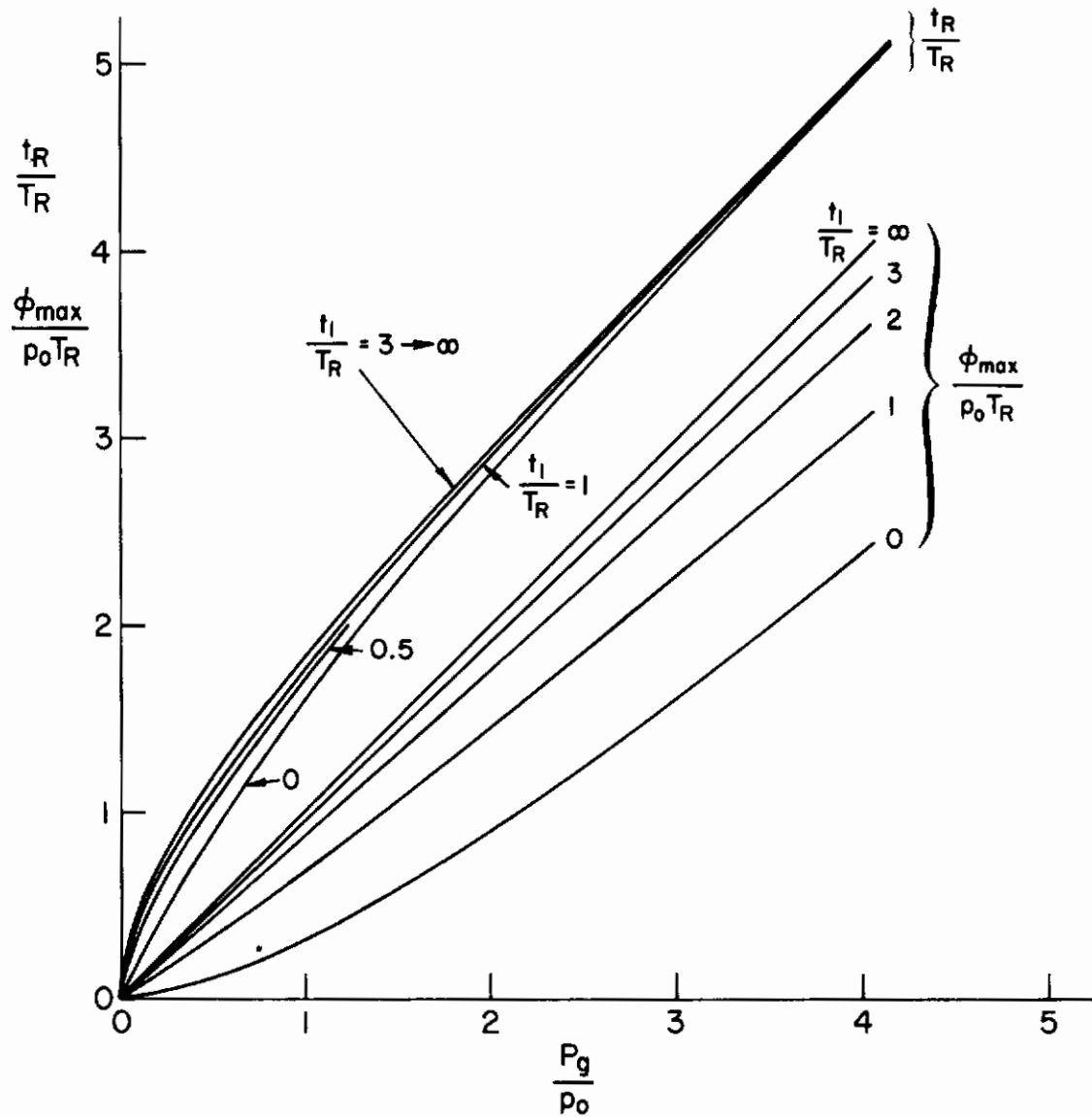

Figure 4. Recovery Time and Roll Excursion  
Following an Impulsive Gust Upset

# Contrails

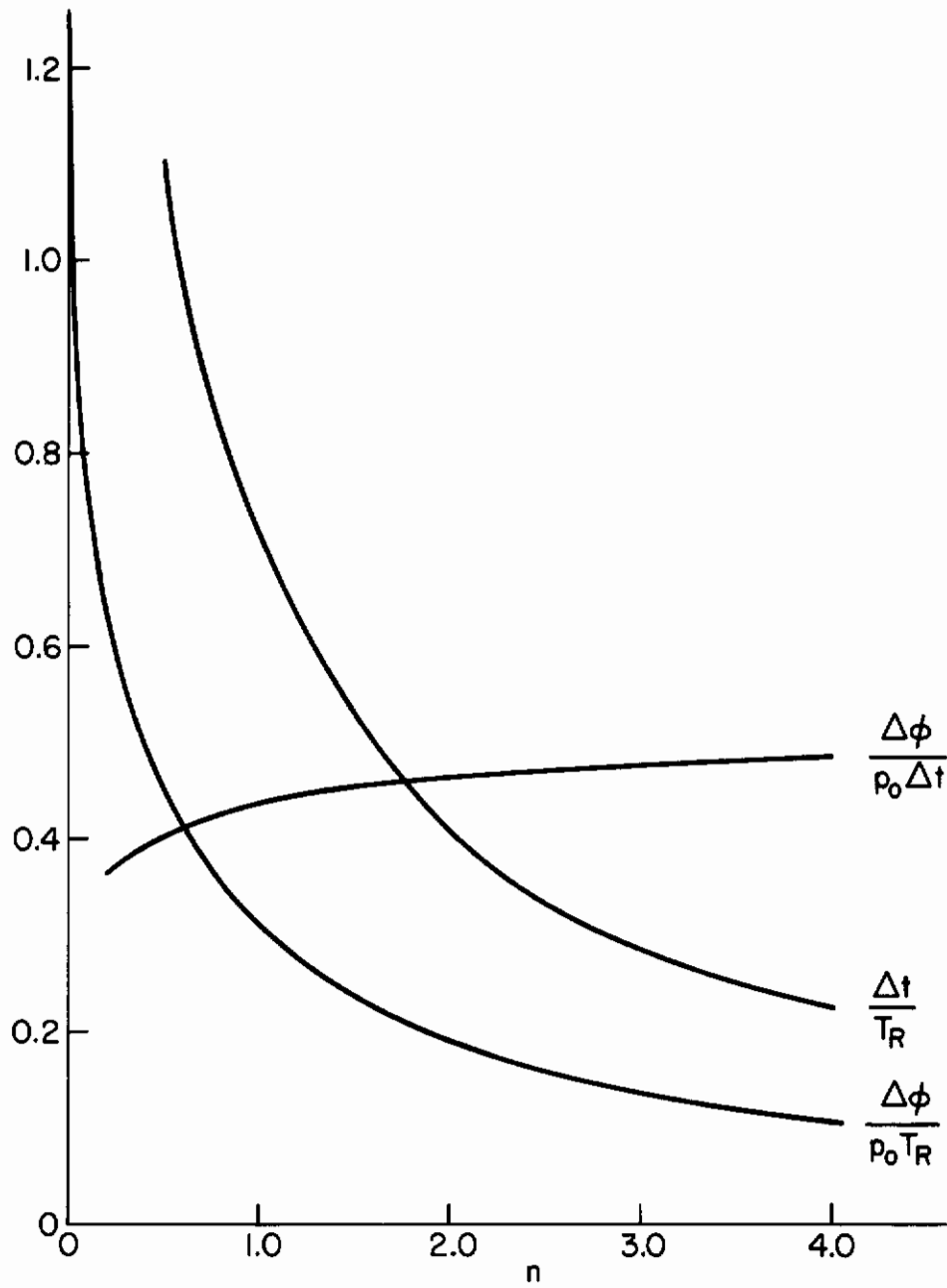

Figure 5. Stopping Bank Angle and Time Versus Ratio of Stopping to Starting Aileron Angle

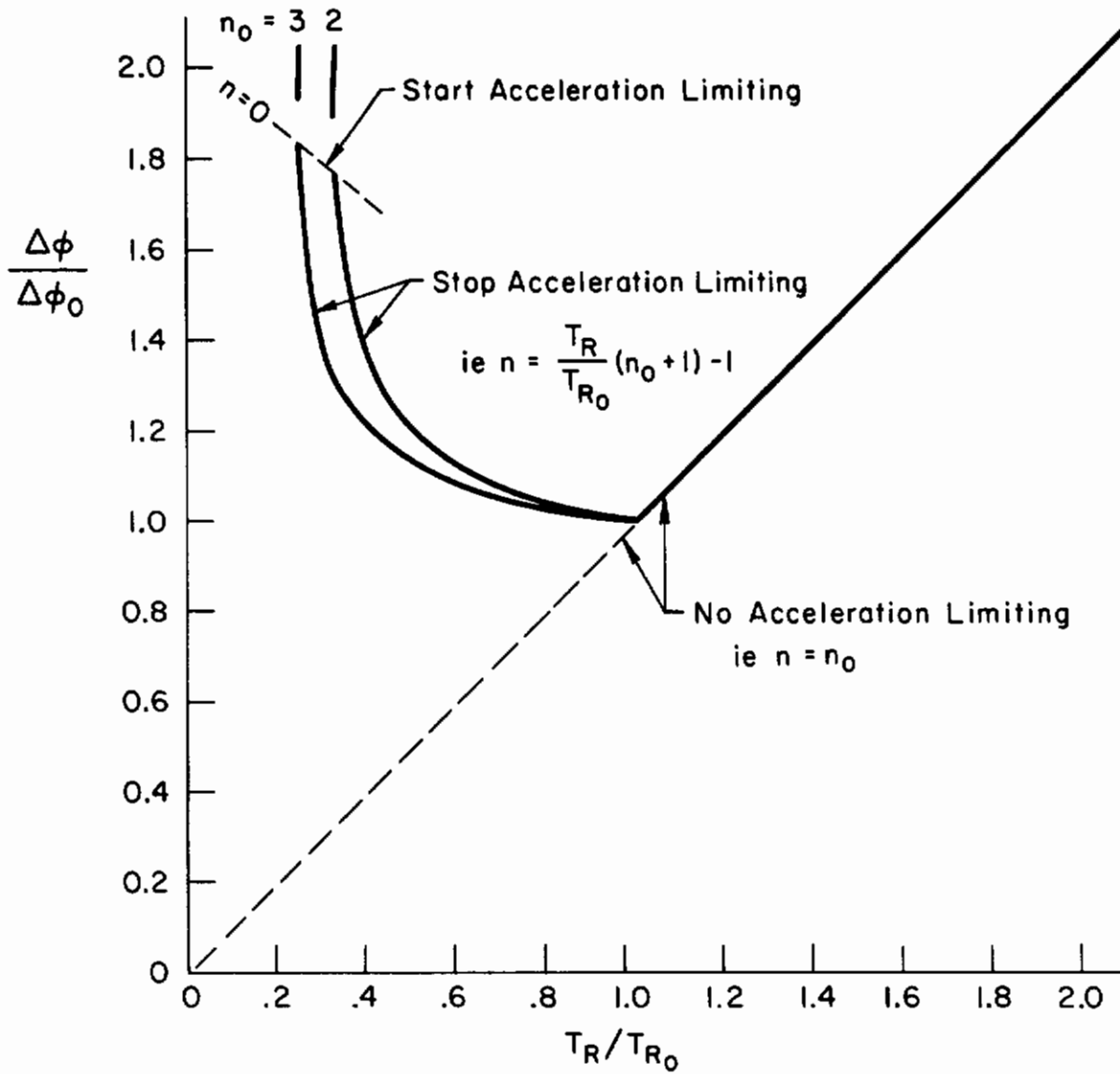

Figure 6. Acceleration Limiting Effects on Stopping Bank Angle



# Contrails

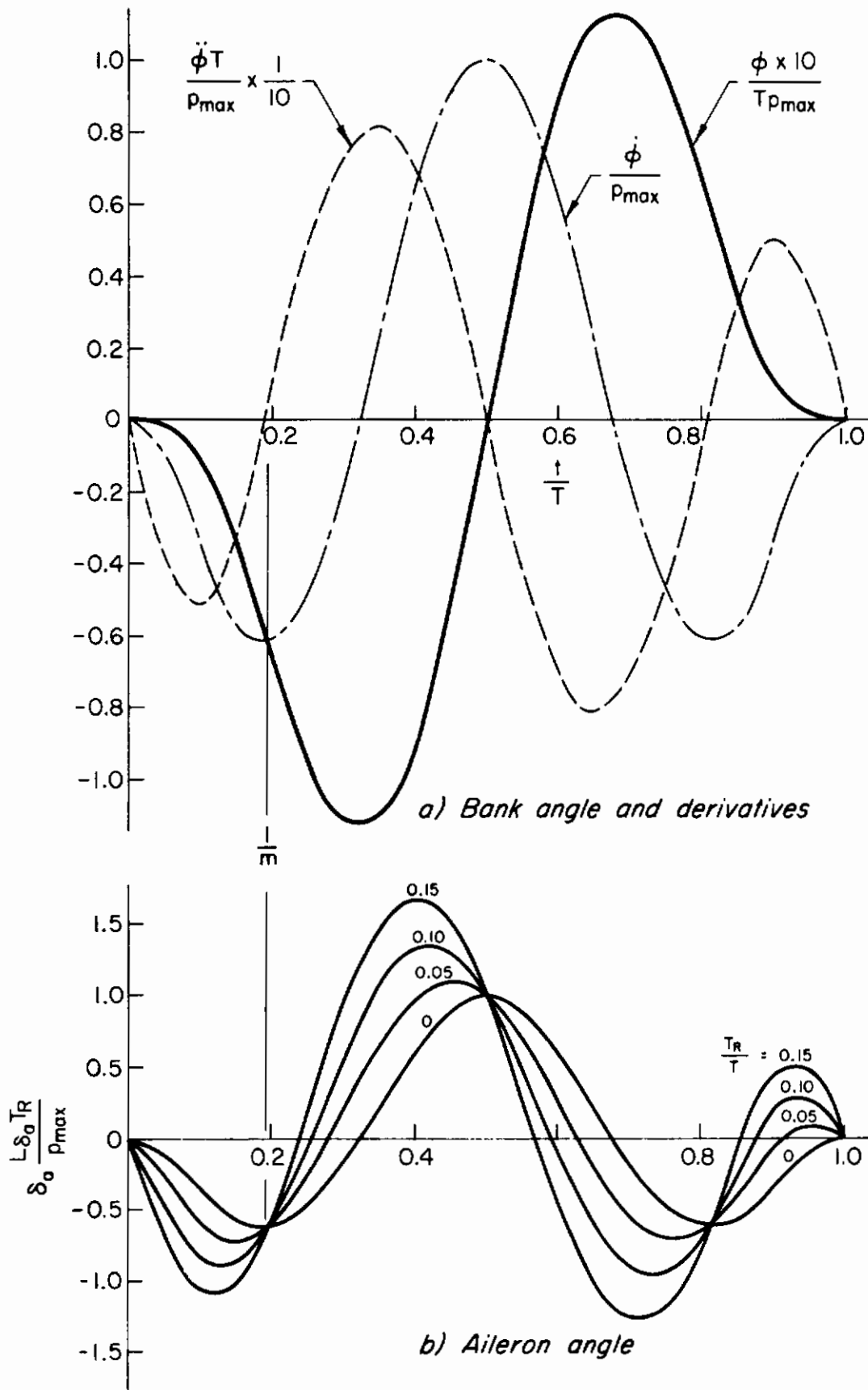

Figure 7. Bank Angle and Aileron Time Histories for Sidestep

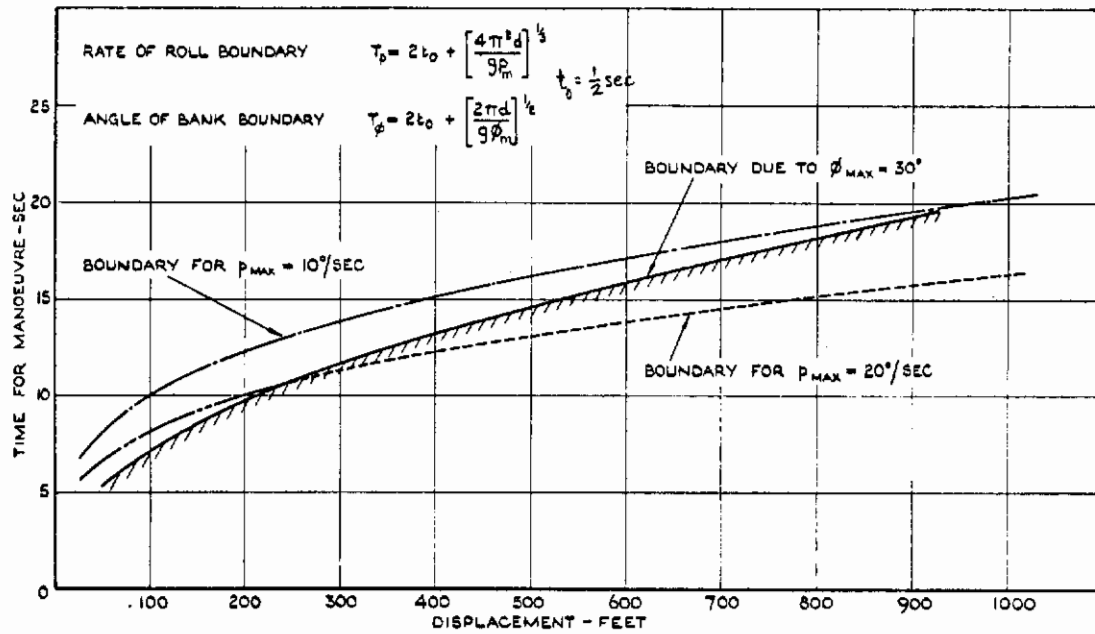

Figure 8. Theoretical Minimum Times for Sinusoidal Maneuvers Limited by Rate of Roll

(Fig. 28 of Ref. 8)

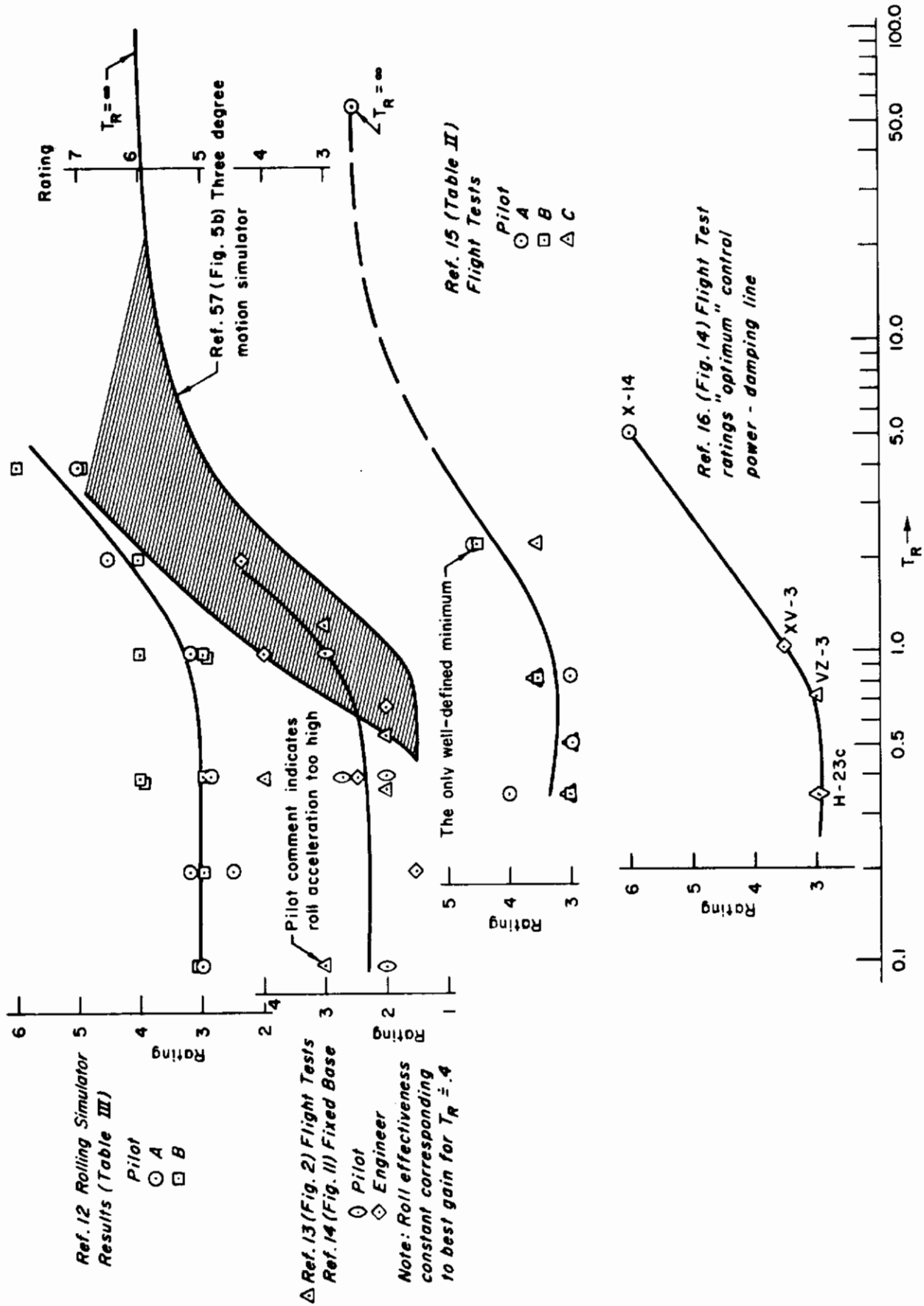
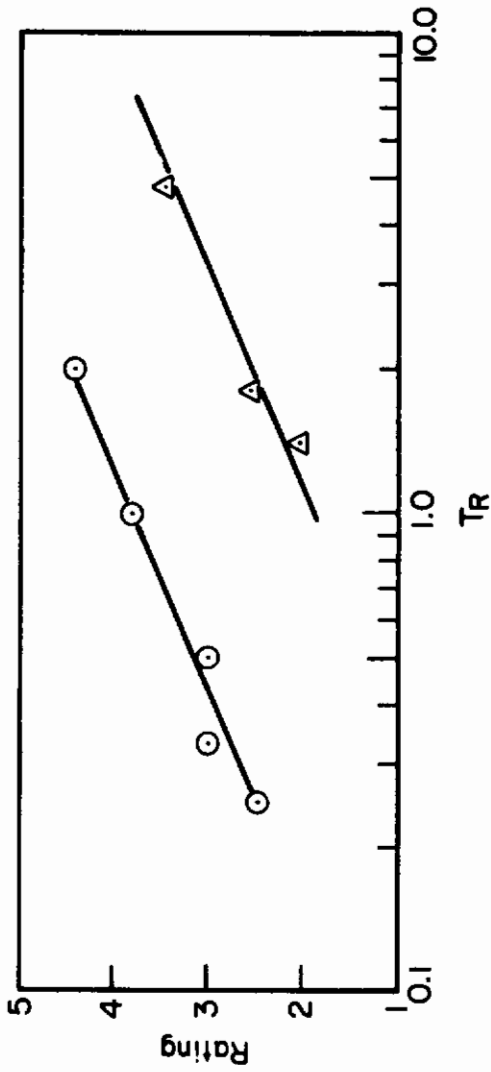

Figure 9. Ratings Versus Roll Damping - Flight Test, Moving-Base, Fixed-Base with Random Input



**Ref. 12 fixed base results  
(Table II)**

**Pilot**  
 ○ A  
 □ B

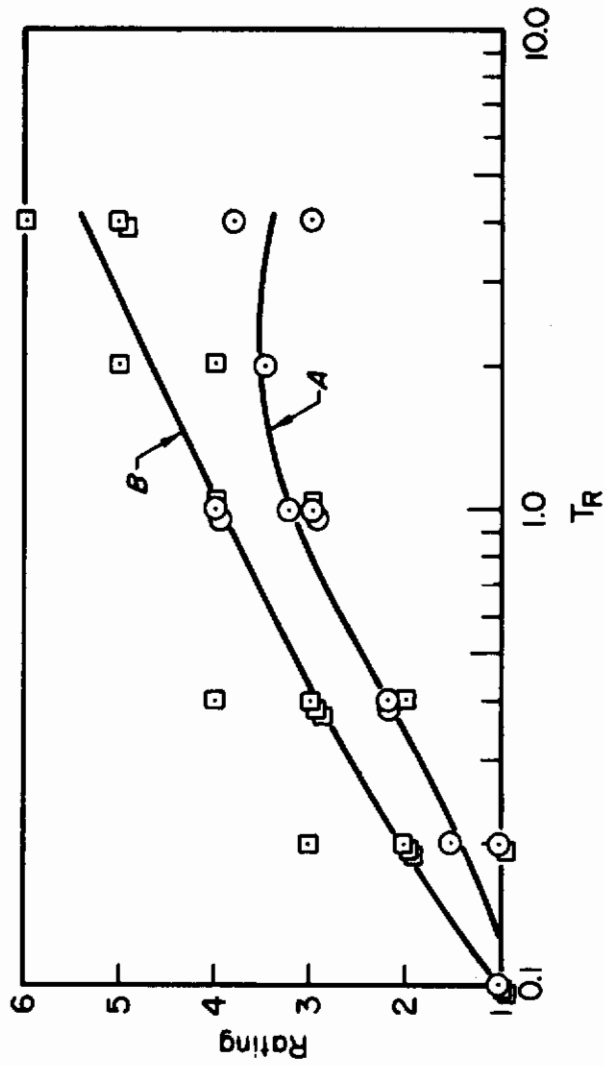

Figure 10. Ratings Versus Roll Damping — Fixed-Base Without Random Input

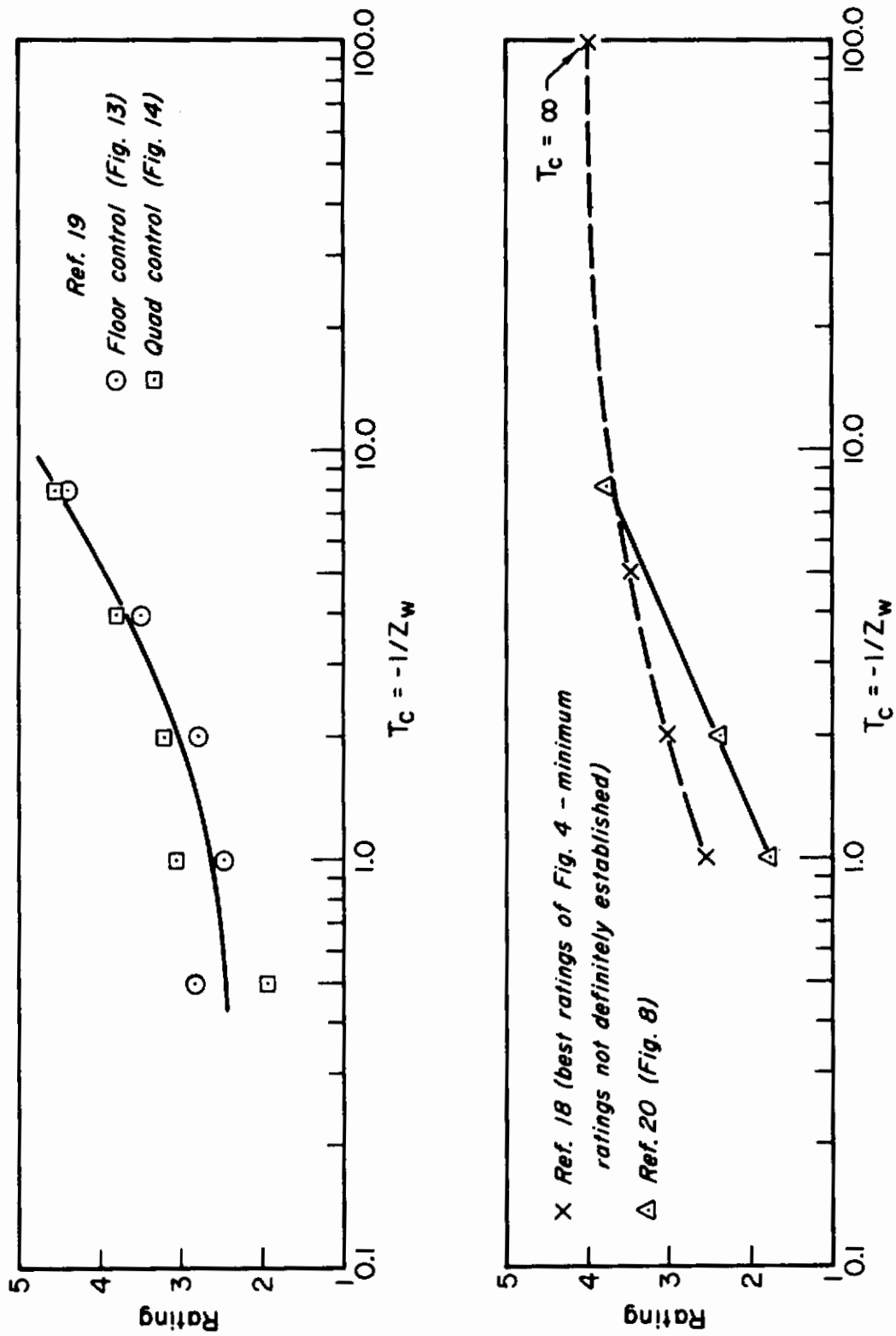

Figure 11. "Best" Height Control Ratings Versus  $-1/Z_w$

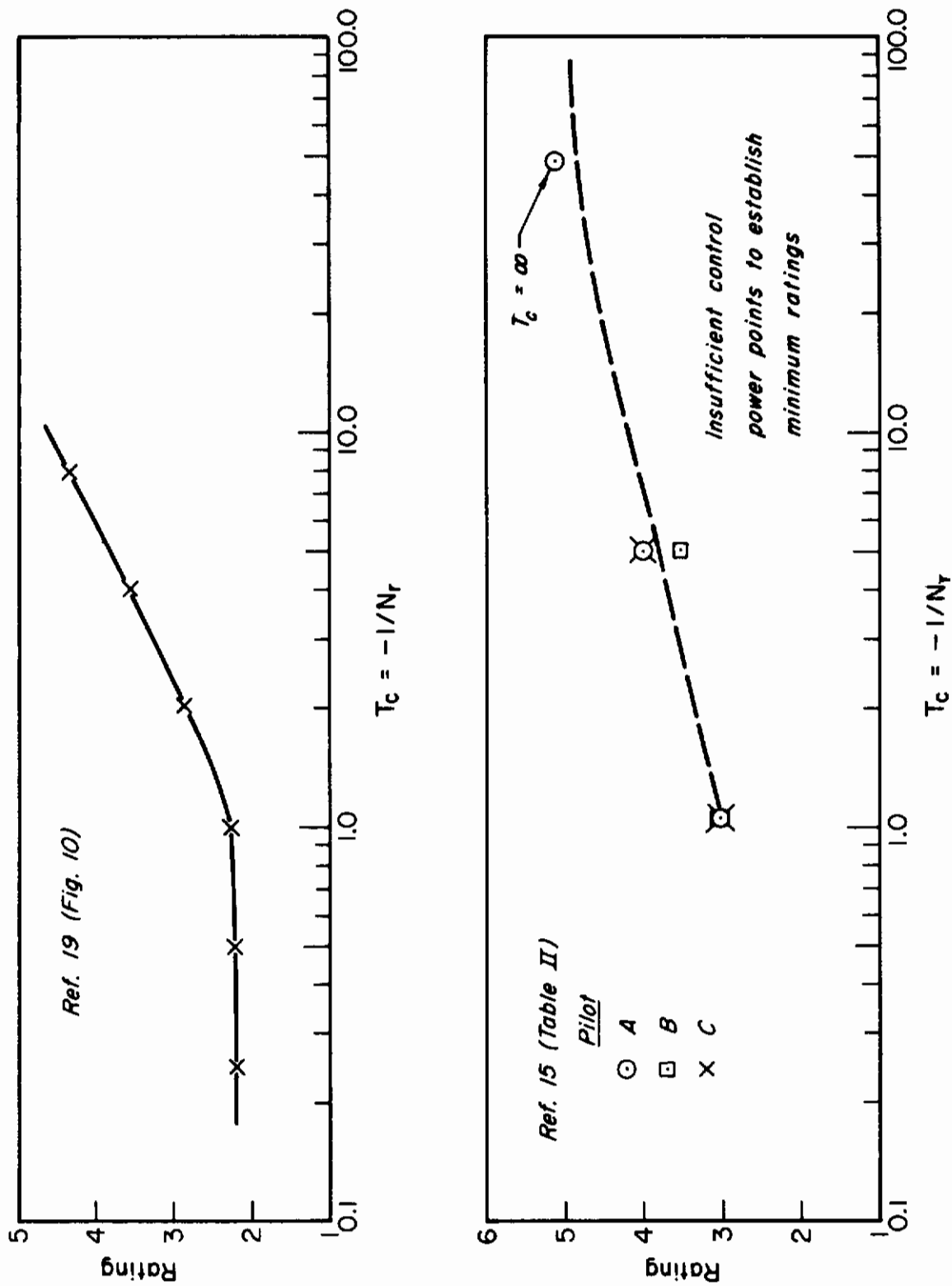

Figure 12. "Best" Yaw Control Ratings Versus  $-1/N_r$

# Contrails

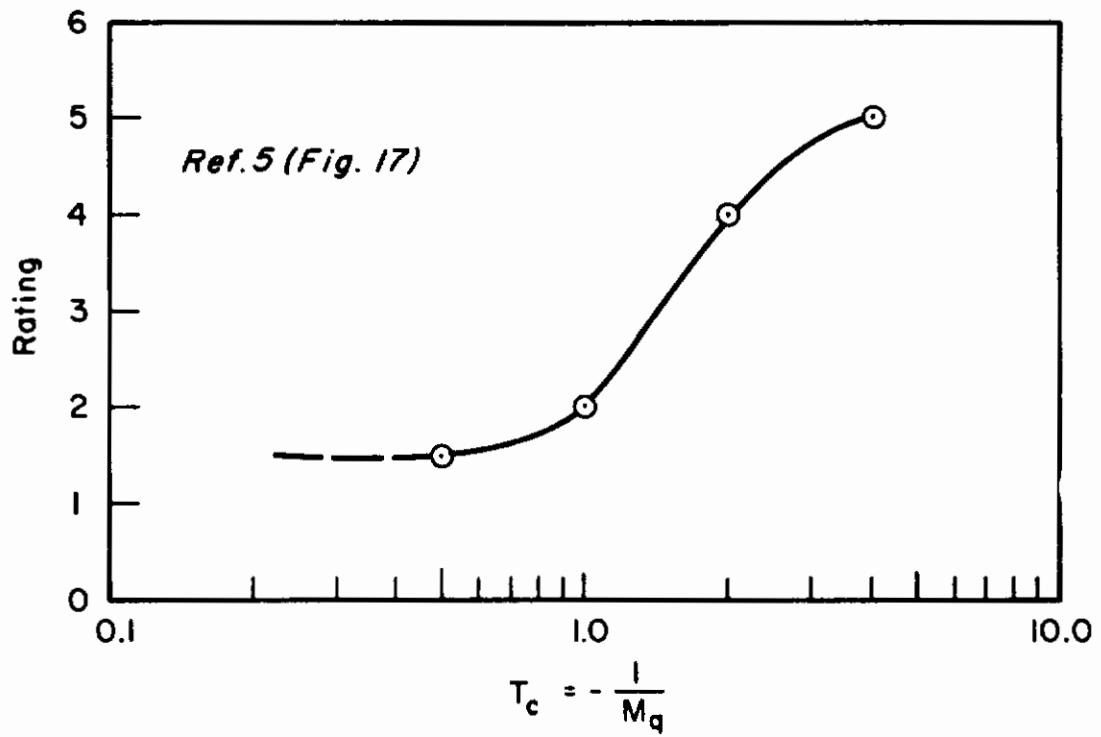

Figure 13. "Best" Pitch Control Ratings Versus  $-1/M_q$

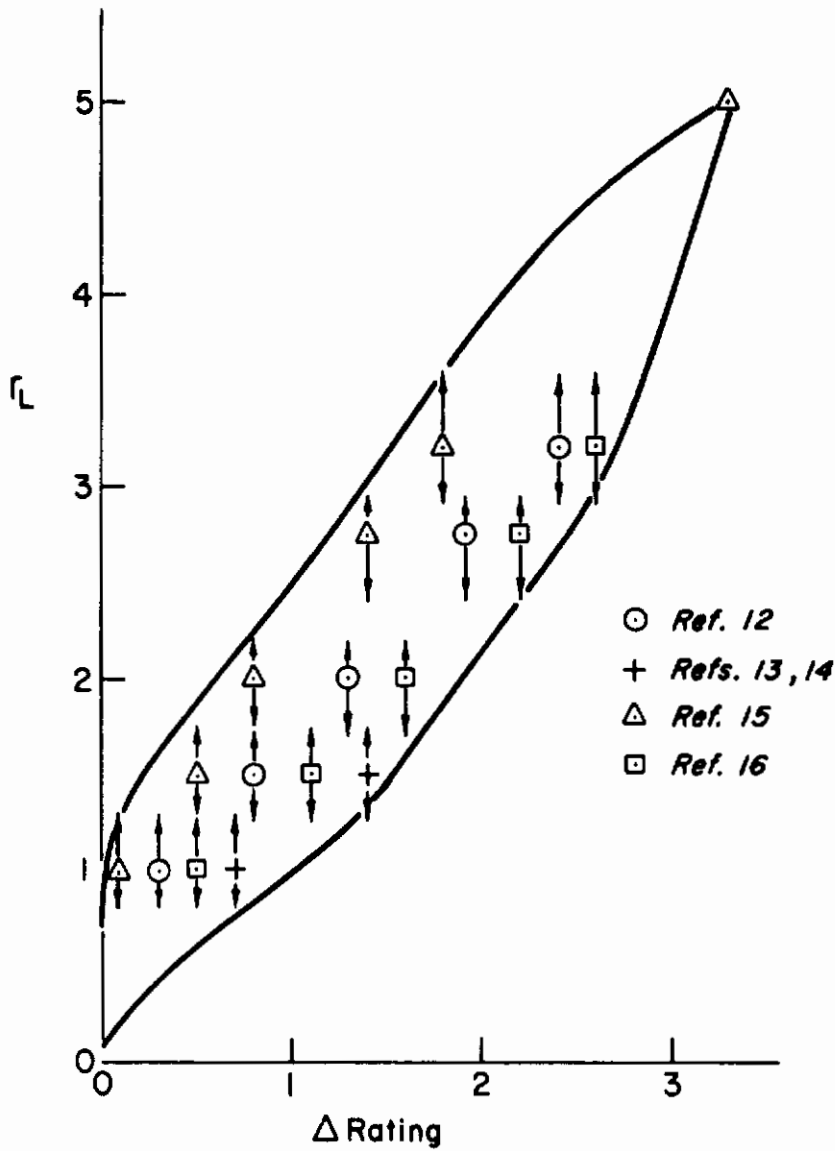

Figure 14.  $T_L$  Versus  $\Delta$  Rating Inferred From Handling Qualities Tests



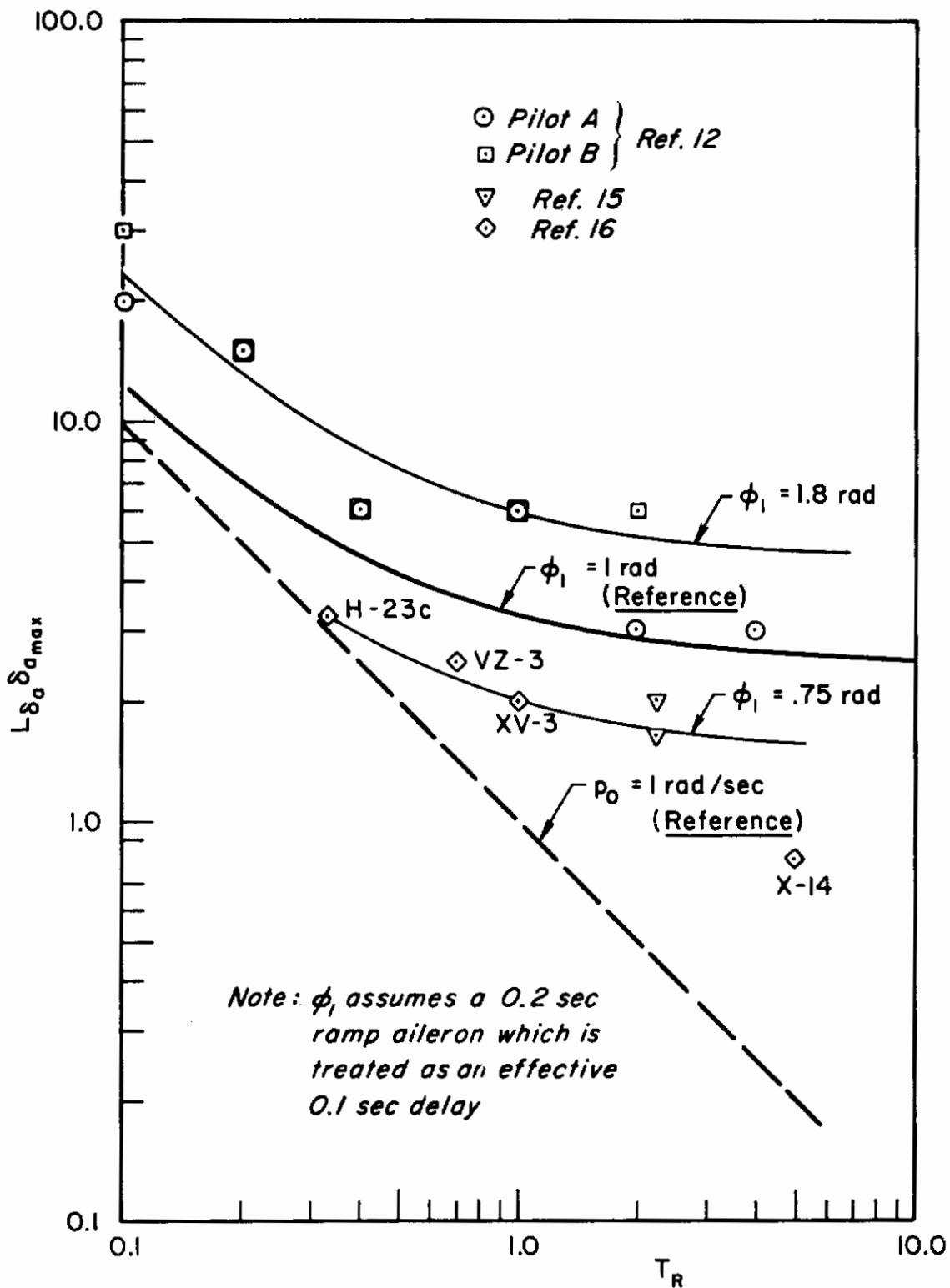

Figure 15. Roll Power—Best Opinion Correlations

# Contrails

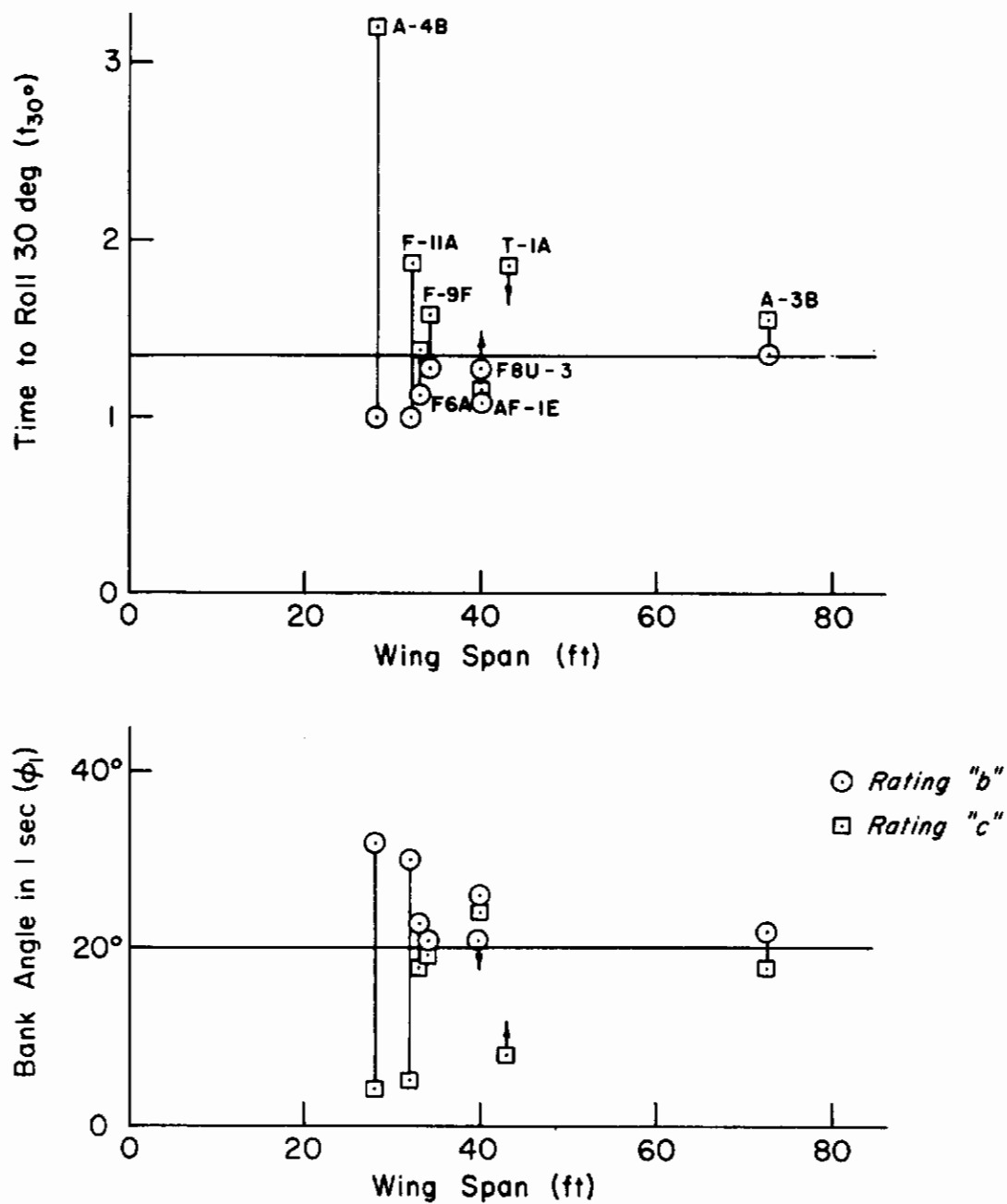

Figure 16. Marginal Landing-Approach Roll Performance Data of Ref. 24

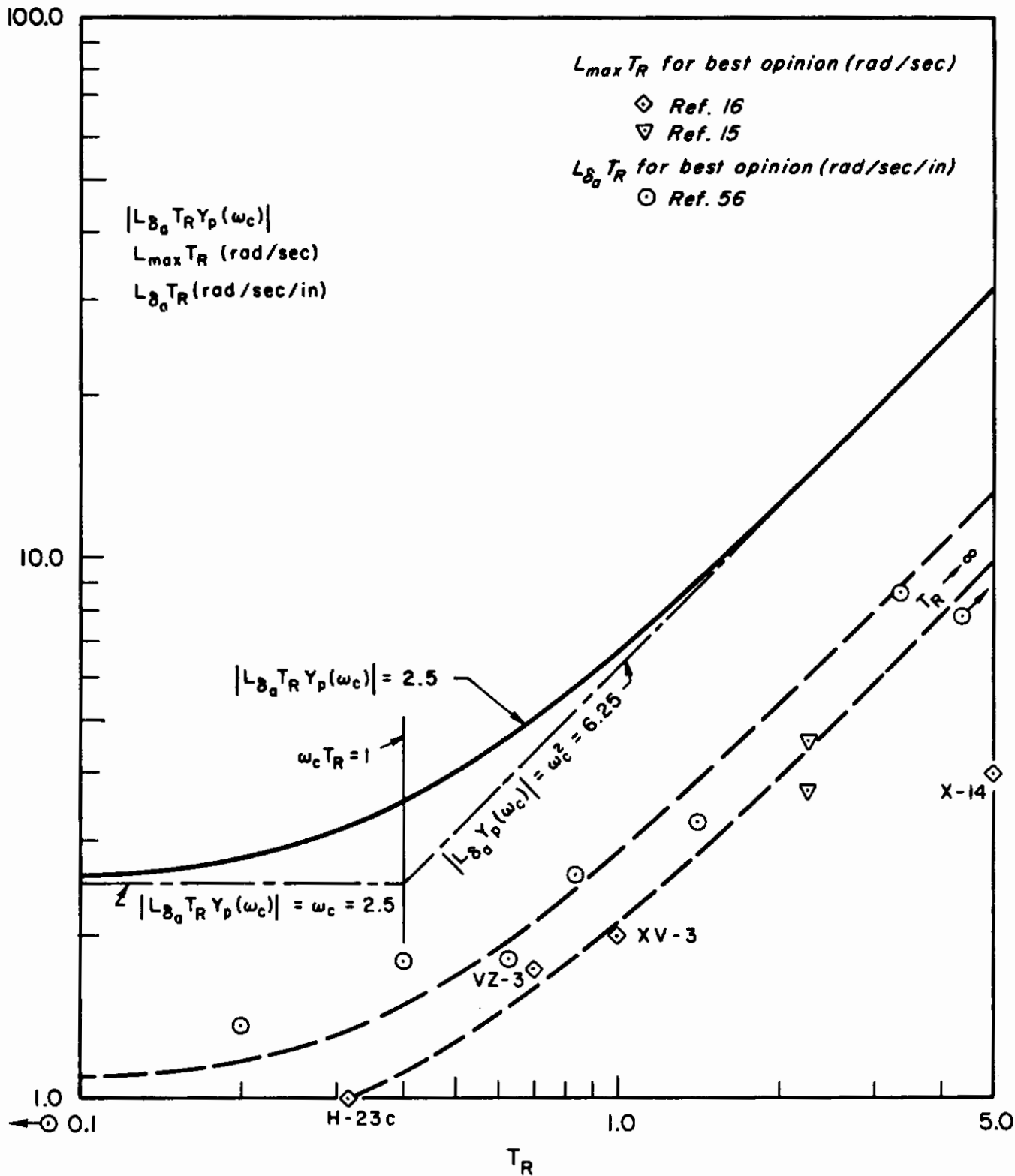

Figure 17. Gain at Crossover Frequency,  $\omega_c = 2.5$  Rad/Sec

## APPENDIX

### COMMENTS RECEIVED ON DRAFT VERSION OF REPORT (STI WP-133-4)

F/L T. M. Harris, AFFDL-FDCC.....Letter 11/64

1. Conclusion 3 of Section IV not supported by Fig. 8 because of error in figure.
2. Presentation of Section V confusing because of poor delineation between important and secondary effects.
3. Upsets due to jet wash should be considered.
4. Effect of roll capability on obstacle avoidance not clearly described.
5. Questions prior establishment of mission-centered maneuver requirements, i.e., can't always predict all possible uses to which vehicle may be put.
6. Tail chase discussion also implies that the lead pilot needs all the roll velocity he can get.
7. In general should consider maneuvers in other than horizontal plane.
8. Regarding sidestep maneuver, roll rate requirements might be less arbitrary if it were possible to establish definite requirements on lateral displacement.
9. Concur that gust recovery time appears to be a significant parameter and that three seconds represents an absolute maximum.
10. The optimum gain discussion nicely ties theory and experiment together and the conclusions are well supported.

A. W. Shaw, LTV Vought Aeronautics Division.....Letter 1/26/65

1. Fixed-base simulator studies (at LTV) support notion that pilot uses pulses to control  $K/s^2$ .
2. Remaining comments pertain to IFR, VTOL hover damping requirements obtained from six-degree-of-freedom fixed-base simulation.

# Contrails

Ellis McBride, Lockheed-Georgia Company.....Telecon 1/28/65

Table II not clear on the starting time for bank angle response measurements.

J. W. Carlson, SEG-SEFDS.....Letter 1/29/65

1. Provides good understanding of when and how lateral controls are used.
2. C-141 now rated minimum acceptable has maximum roll rates of  $10^{\circ}$  to  $12^{\circ}$ /second and time to  $30^{\circ}$  of 3.5 seconds.
3. Current bank angle in one second requirement is a severe (and, in retrospect, perhaps unwarranted) task for the aileron actuation system.

Larry Taylor, NASA-FRC:.....Verbal 2/2/65

No objection to handling of subject, but considers it only a first step in a complicated problem.

Robert J. Tapscott, NASA-IRC.....Letter 2/16/65

1. Theoretical treatment of apparent potential for attaching mathematical significance to pilot opinion variations.
2. There has been confusion in past attempts to correlate pilot opinion with selected aircraft parameters which may not have been sufficiently representative of pilot desires.
3. Results should be summarized and interpreted into general guide lines useful in planning handling qualities experiments.
4. Indications or trends which pertain to variations in desired handling qualities with aircraft size should be highlighted.

# Contrails

Mel Sadoff, NASA-ARC.....Letter 3/30/65

1. Lots of factors which may be important, but no delineation of really significant ones.
2. Would like to see Table II expanded to include other pertinent factors such as  $I_p'$ ,  $N_p'$ ,  $\zeta_d$ , etc., so that combined "explanations" of this report and Ref. 1 could be checked.
3. Single-degree control situation limits value of discussions.
4. Recent human response measurements (Elkind) show no degradation in performance or  $\omega_c$  for two-axis tasks for controlled elements K, K/s, K/s<sup>2</sup>.
5. Recent results on a variable-stability helicopter (IRC) indicate that without external disturbances a bang-bang system reduces control power to one-third that for a proportional control with a significant improvement in pilot opinion. This may be because it is easier to apply controlled pulses for the K/s<sup>2</sup> dynamics involved.
6. With  $\omega_c$  set at 2.5, do  $\omega_H$ 's greater than 2.5 result in degraded bank angle control in rough air and are there any data on this question?
7. Decreasing  $T_R$  will improve  $|\phi/\beta|_d$  and should generally be helpful; therefore not convinced that values of  $T_R$  below 0.5 to 1.0 do not improve pilot rating.
8. Should sidestep maneuver be classified as primarily open loop?
9. Suggests deleting acceleration-limiting discussion.
10. Suggests expanding discussion to include possible roll damping requirements based on good sidestep maneuver performance and gust response attenuation.
11. Re fighter airplanes in Table II, the separation of unsatisfactory from satisfactory based on  $\phi_1$  between 45° and 60° is no more convincing than one based on  $p_0$  between 100°/second and 150°/second if F-100C (an oddball anyway) is not included.
12. Section VI, if included at all, should be included earlier, probably in Section II.

UNCLASSIFIED

Security Classification

DOCUMENT CONTROL DATA - R&D

(Security classification of title, body of abstract and indexing annotation must be entered when the overall report is classified)

|  |  |   |                        |
|--|--|---|------------------------|
| 1. ORIGINATING ACTIVITY (Corporate author)<br>Systems Technology, Inc.<br>13766 South Hawthorne Blvd<br>Hawthorne, California  |  | 2a. REPORT SECURITY CLASSIFICATION<br>UNCLASSIFIED                                  |                        |
|  |  | 2b. GROUP<br>N/A  |                        |
| 3. REPORT TITLE<br>A Study of Conventional Airplane Handling Qualities Criteria<br>Part I: Roll Handling Qualities<br>Part II: Lateral-Directional Oscillatory Handling Qualities  |  |   |                        |
| 4. DESCRIPTIVE NOTES (Type of report and inclusive dates)<br>Final Report  |  |   |                        |
| 5. AUTHOR(S) (Last name, first name, initial)<br>Irving L. Ashkenas  |  |   |                        |
| 6. REPORT DATE<br>November 1965  |  | 7a. TOTAL NO. OF PAGES<br>128   | 7b. NO. OF REFS<br>103 |
| 8a. CONTRACT OR GRANT NO.<br>AF33(657)-10407   |  | 9a. ORIGINATOR'S REPORT NUMBER(S)<br>AFFDL-TR-65-138, Part I                        |                        |
| b. PROJECT NO.<br>8219   |  | 9b. OTHER REPORT NO(S) (Any other numbers that may be assigned this report)<br>None |                        |
| c. Task No<br>821905   |  |   |                        |
| d.   |  |   |                        |
| 10. AVAILABILITY/LIMITATION NOTICES<br>None  |  |   |                        |
| 11. SUPPLEMENTARY NOTES<br>None  |  | 12. SPONSORING MILITARY ACTIVITY<br>AFFDL (FDCC)<br>Wright-Patterson AFB, Ohio      |                        |
| 13. ABSTRACT This report is a codification in two parts of conventional aircraft handling qualities criteria. The results of this effort are to serve as an intermediate design guide in the areas of lateral-directional oscillatory and roll control. All available data applicable to these problem areas were considered in developing the recommended new criteria. Working papers were sent to knowledgeable individuals in industry and research agencies for comments and suggestions, and these were incorporated in the final version of this report. The roll handling qualities portion of this report uses as a point of departure the concept that control of bank angle is the primary piloting task in maintaining or changing heading. Regulation of the bank angle to maintain heading is a closed-loop tracking task in which the pilot applies aileron control as a function of observed bank angle error. For large heading changes, the steady-state bank angle consistent with available or desired load factor is attained in an open-loop fashion; it is then regulated in a closed-loop fashion throughout the remainder of the turn. For the transient entry and exit from the turn, the pilot is not concerned with bank angle per se, but rather with attaining a mentally commanded bank angle with tolerable accuracy in a reasonable time, and with an easily learned and comfortable program of aileron movements. In the lateral oscillatory portion of this effort, in defining requirements for satisfactory Dutch roll characteristics, a fundamental consideration is the fact that the motions characterizing this mode are ordinarily not the pilot's chief objective. That is, he is not deliberately inducing Dutch roll motions in the sense that he induces rolling and longitudinal short-period motions. |  |   |                        |

DD FORM 1 JAN 64 1473

UNCLASSIFIED

Security Classification

# *Contrails*

13. (Continued) Dutch roll oscillations are side products of his attempts to control the airplane in some other mode of response, and they are in the nature of nuisance effects which should be reduced to an acceptable level. In spite of its distinction as a side effect, adequate control of Dutch roll is a persistent handling qualities research area and a difficult practical design requirement. The difficulties stem from the many maneuver and control situations which can excite the Dutch roll, and from its inherently low damping. Since any excitation of the Dutch roll is undesirable, the effects of disturbance inputs are almost uniformly degrading to pilot opinion rating. Nevertheless, removal of such influence does not eliminate the need for some basic level of damping. A worthwhile approach to establishment of Dutch roll damping requirements is to first establish the basic level, and then to study the varied influences of the disturbance parameters. This approach provides the basis for the material contained in this report.



|    |           |        |        |        |
|----|-----------|--------|--------|--------|
| 14 | KEY WORDS | LINK A | LINK B | LINK C |
|    |           | ROLE   | WT     | ROLE   |
|    |           | ROLE   | WT     | ROLE   |
|    |           | WT     | WT     | WT     |

Handling Qualities  
 Lateral-directional Handling Qualities  
 Roll Handling Qualities  
 Handling Qualities Requirements  
 Airplane Handling Qualities

### INSTRUCTIONS

1. **ORIGINATING ACTIVITY:** Enter the name and address of the contractor, subcontractor, grantee, Department of Defense activity or other organization (*corporate author*) issuing the report.
- 2a. **REPORT SECURITY CLASSIFICATION:** Enter the overall security classification of the report. Indicate whether "Restricted Data" is included. Marking is to be in accordance with appropriate security regulations.
- 2b. **GROUP:** Automatic downgrading is specified in DoD Directive 5200.10 and Armed Forces Industrial Manual. Enter the group number. Also, when applicable, show that optional markings have been used for Group 3 and Group 4 as authorized.
3. **REPORT TITLE:** Enter the complete report title in all capital letters. Titles in all cases should be unclassified. If a meaningful title cannot be selected without classification, show title classification in all capitals in parenthesis immediately following the title.
4. **DESCRIPTIVE NOTES:** If appropriate, enter the type of report, e.g., interim, progress, summary, annual, or final. Give the inclusive dates when a specific reporting period is covered.
5. **AUTHOR(S):** Enter the name(s) of author(s) as shown on or in the report. Enter last name, first name, middle initial. If military, show rank and branch of service. The name of the principal author is an absolute minimum requirement.
6. **REPORT DATE:** Enter the date of the report as day, month, year, or month, year. If more than one date appears on the report, use date of publication.
- 7a. **TOTAL NUMBER OF PAGES:** The total page count should follow normal pagination procedures, i.e., enter the number of pages containing information.
- 7b. **NUMBER OF REFERENCES:** Enter the total number of references cited in the report.
- 8a. **CONTRACT OR GRANT NUMBER:** If appropriate, enter the applicable number of the contract or grant under which the report was written.
- 8b, 8c, & 8d. **PROJECT NUMBER:** Enter the appropriate military department identification, such as project number, subproject number, system numbers, task number, etc.
- 9a. **ORIGINATOR'S REPORT NUMBER(S):** Enter the official report number by which the document will be identified and controlled by the originating activity. This number must be unique to this report.
- 9b. **OTHER REPORT NUMBER(S):** If the report has been assigned any other report numbers (*either by the originator or by the sponsor*), also enter this number(s).
10. **AVAILABILITY/LIMITATION NOTICES:** Enter any limitations on further dissemination of the report, other than those

imposed by security classification, using standard statements such as:

- (1) "Qualified requesters may obtain copies of this report from DDC."
- (2) "Foreign announcement and dissemination of this report by DDC is not authorized."
- (3) "U. S. Government agencies may obtain copies of this report directly from DDC. Other qualified DDC users shall request through \_\_\_\_\_."
- (4) "U. S. military agencies may obtain copies of this report directly from DDC. Other qualified users shall request through \_\_\_\_\_."
- (5) "All distribution of this report is controlled. Qualified DDC users shall request through \_\_\_\_\_."

If the report has been furnished to the Office of Technical Services, Department of Commerce, for sale to the public, indicate this fact and enter the price, if known.

11. **SUPPLEMENTARY NOTES:** Use for additional explanatory notes.
12. **SPONSORING MILITARY ACTIVITY:** Enter the name of the departmental project office or laboratory sponsoring (*paying for*) the research and development. Include address.
13. **ABSTRACT:** Enter an abstract giving a brief and factual summary of the document indicative of the report, even though it may also appear elsewhere in the body of the technical report. If additional space is required, a continuation sheet shall be attached.

It is highly desirable that the abstract of classified reports be unclassified. Each paragraph of the abstract shall end with an indication of the military security classification of the information in the paragraph, represented as (TS), (S), (C), or (U).

There is no limitation on the length of the abstract. However, the suggested length is from 150 to 225 words.

14. **KEY WORDS:** Key words are technically meaningful terms or short phrases that characterize a report and may be used as index entries for cataloging the report. Key words must be selected so that no security classification is required. Identifiers, such as equipment model designation, trade name, military project code name, geographic location, may be used as key words but will be followed by an indication of technical context. The assignment of links, rules, and weights is optional.

# *Contrails*