

WADC TECHNICAL REPORT 54-160

**VISUAL PRESENTATION OF INFORMATION**

*Charles A. Baker  
Walter F. Grether*

*Aero Medical Laboratory*

*August 1954*

**Project No. 7180**

**Wright Air Development Center  
Air Research and Development Command  
United States Air Force  
Wright-Patterson Air Force Base, Ohio**

Carpenter Litho & Prtg. Co., Springfield, O.  
1100 - 7 October 1954

# Contrails

## FOREWORD

This report was prepared under Research and Development Project Number 7180, Human Engineering Applications to Equipment Design, of the Psychology Branch, Aero Medical Laboratory, Directorate of Research, Wright Air Development Center, with Dr. Walter F. Grether as Project Scientist.

This report is being issued as a preliminary draft of a part of the Human Engineering Guide to Equipment Design being prepared under the direction of the Joint Services Steering Committee for this guide. After further review and revision it is planned that this material will become the part of that guide which deals with the visual presentation of information. The purpose of the Human Engineering Guide to Equipment Design is to provide designers of military equipment with human engineering data and general design recommendations for maximizing efficiency of human operation and use.

Users of this report are invited to submit to the authors comments which would be useful in revising or adding to this material prior to its publication in the Joint Services Human Engineering Guide to Equipment Design.

This report has been released to the Armed Services Technical Information Agency, Knott Building, Dayton 2, Ohio. This report has further been released to the Office of Technical Services, Department of Commerce, Washington 25, D.C. for sale to the general public.

The authors are especially grateful to Dr. Alphonse Chapanis of the Johns Hopkins University for his technical review of this report in draft form. On the basis of his suggestions many changes were made. Similarly, many helpful suggestions were incorporated from other members of the Psychology Branch of the Aero Medical Laboratory, and from engineers from other Wright Air Development Center laboratories. The art work was provided by Mrs. Jane McCulloch and Mr. Jerry Acton of the Psychology Branch. Dr. Dean Chiles, Psychology Branch, and Mr. Lee Jones, Services Branch, assisted in the editing of the final manuscript.

An important factor in the design of equipment for maximum efficiency of human operation is the design, illumination, and arrangement of visual displays which provide information to the human operator. This report provides a compilation of general human engineering recommendations and presents some of the supporting data which should aid the engineer in providing the most satisfactory visual presentations of information. The report is divided into seven chapters entitled: Mechanical Indicators, Warning Devices, Cathode-Ray Tubes and Signal Coding, Printed Materials, Instrument Panel Layout, Lighting, and Visual Detection and Identification. Liberal use is made of pictorial, graphic, and tabular presentations to illustrate the data and design recommendations. A table of contents, subject index, and a selected bibliography are included as an aid to the user.

## PUBLICATION REVIEW

This report has been reviewed and is approved.

FOR THE COMMANDER :

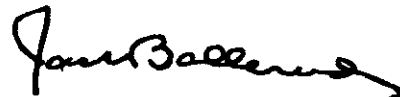

JACK BOLLERUD  
Colonel, USAF (MC)  
Chief, Aero Medical Laboratory  
Directorate of Research

**TABLE OF CONTENTS**

1. **Mechanical Indicators** . . . . . 1  
    General considerations . . . . . 1  
    Selection of mechanical symbolic indicators . . . . . 3  
    Selection of mechanical pictorial indicators . . . . . 7  
    General design recommendations . . . . . 10  
    Scale design . . . . . 14  
    Instrument zone markings . . . . . 21  
    Pointer design . . . . . 22  
    Instrument identification . . . . . 23  
    Numerals and letters . . . . . 24

2. **Warning Devices** . . . . . 25  
    Warning lights . . . . . 25  
    Caution indicators . . . . . 26  
    On-off indicators . . . . . 26

3. **Cathode-Ray Tubes and Signal Coding** . . . . . 27  
    Introduction . . . . . 27  
    Cathode-ray tube resolution . . . . . 29  
    Cathode-ray tube visibility . . . . . 30  
    Workplace lighting and cathode-ray tube displays . . . . . 37  
    Methods for indicating range on radar displays . . . . . 40  
    Methods for indicating bearing on radar displays . . . . . 43  
    Three coordinate information displays . . . . . 45  
    Visual coding - The display of additional target data . . . . . 46

4. **Printed Materials** . . . . . 56  
    Legibility of printed matter . . . . . 56  
    Books, pamphlets, and detailed instruction cards . . . . . 56  
    Decals, check lists, and labels . . . . . 57  
    Graphs, tables, and scales for numerical data . . . . . 58

# Contrails

5. Instrument Panel Layout . . . . .	59
Check list for good panel layout . . . . .	59
Representation of planes in space . . . . .	59
Instrument priority, position, viewing angle, and distance . . . . .	64
Instrument arrangement and pointer alignment . . . . .	65
Combination of instruments . . . . .	66
6. Lighting . . . . .	69
Definition of terms . . . . .	69
General workplace lighting . . . . .	75
Instrument and control console lighting . . . . .	81
7. Visual Detection and Identification . . . . .	87
Visual acuity . . . . .	87
Detection and recognition of colored targets . . . . .	96
Pattern recognition and identification . . . . .	98
Magnification aids to vision . . . . .	99
Visual estimation of size, range, velocity, and acceleration . . . . .	100
Appendix . . . . .	101
Subject Index . . . . .	103
Bibliography . . . . .	106

# *Contrails*

*Controls*  
chapter 1  
mechanical indicators

## GENERAL CONSIDERATIONS

Mechanical indicators are those instruments in which there is motion of a mechanical indicating element. There may or may not be a numerical scale. The moving element may be a pointer or other reference marker, or it may be a fluid column. The scale may be the moving element, with the pointer or reference marker fixed. In some cases both the scale and pointer may move. Where the information is nonquantitative, as on a landing gear position indicator, the moving element may give a pictorial representation. The following are examples of the types of mechanical indicators: Moving pointer with a fixed scale, moving scale with a fixed pointer, direct reading counter, liquid column instrument (thermometers), slide rules and similar computing devices, pictorial indicators (landing gear position, aircraft attitude), and rotary selection switches.

**METHODS OF USE:** In designing any type of visual indicator it is of utmost importance to consider the ways in which the operator will use the information being presented. This will normally require an analysis of the types of action the operator will be expected to take during or after his viewing of the indicator. Generally, the use of any indicator can be classified on the basis of one or more of the following categories.

**Quantitative reading:** Reading to an exact numerical value.

**Qualitative reading:** Judging in a qualitative way the approximate value, the approximate deviation from a normal or desired value, and the direction from a normal or desired value.

**Check reading:** Verifying that a normal or desired value is being indicated.

**Setting:** Adjusting an indicator to a desired value, usually to an exact numerical value, or to match another indicator.

**Tracking:** Intermittent or continuous adjustment of an instrument to maintain a normal or desired value (compensatory tracking) or to follow a moving reference marker (pursuit tracking).

The first three of these categories, quantitative, qualitative, and check reading, refer to the reading of the instruments without consideration of the type of control over the readings. The remaining two categories refer to the way in which the operator will control the instrument settings. Any single instrument will usually be used in more than one of the categorized ways. To apply properly the design recommendations which follow, an analysis should be made of how the instrument will be used, in terms of the above categories. Most instruments are designed primarily for quantitative reading. In most cases, however, this represents a rather minor part of the use to which the instrument is put. An instrument designed for quantitative reading may handicap the operator for other types of use.

**CONDITIONS OF USE:** The working conditions under which an operator will read instruments must be considered in the design. In order to provide for proper instrument design one must consider the following conditions.

**Reading distance:** Many instruments (as in aircraft) are designed for reading at arm's length to permit the operator to operate switches or adjust controls. This distance is generally set at 28 inches.

**Angle of view:** The preferred viewing angle is normal ( $90^{\circ}$ ) to the plane of the indicator. On large panels, or where more than one operator views the same indicator, there may be considerable deviation from the  $90^{\circ}$  viewing angle. This may introduce excessive parallax or obscuration of portions of the instrument, unless such offset viewing has been allowed for in the design.

**Illumination:** A consideration of utmost importance in design is the illumination under which an instrument is viewed. In many situations, as in aircraft cockpits, instrument illumination must be very low at night to permit adequate outside vision. This influences the requirements for size and spacing of instrument markings. The additional use of red lighting to preserve dark adaptation places restrictions on the use of colored markings for coding purposes.

**Presence of other instruments:** Generally an operator has a number of instruments among which he divides his attention. Inconsistencies in the manner of presentation may confuse the operator and invite reading errors. On the other hand, if instruments serving different functions are similar in appearance the operator may read the wrong instrument.

**Location and method of actuation of related controls:** The design of an indicator is often affected by the location and method of actuation of a knob, switch, or other device used to control the setting. The relation between the indicator and the control should be such that the operator with little or no training will select the correct control and operate it in the proper manner.

**CHECK LIST FOR A GOOD INDICATOR:** Listed below are the characteristics of a good indicator. (Senders and Cohen, 1953) These may serve as a check list for the designer. The sections which follow provide design recommendations for obtaining these characteristics.

It can be read quickly in the manner desired (i.e., quantitative, qualitative, and check).

It can be read as accurately as demanded by the operator's needs, and preferably no more accurately.

It is free of features which produce ambiguity or invite gross reading errors.

The information is provided in the most immediately meaningful form, not requiring mental translation into other units.

Changes in indication are easy to detect.

The indicator is easily identified and distinguished from other instruments.

It tells the operator which controls to use in changing its reading.

It tells the operator in which direction to operate the controls.

The information is current, i.e., lag is minimized.

If inoperative, the instrument cannot be read or the operator is properly warned.



SELECTION OF MECHANICAL SYMBOLIC INDICATORS

DISTINCTION BETWEEN SYMBOLIC AND PICTORIAL INDICATORS

**Symbolic displays:** Instruments that display information symbolically are the most commonly used. They present an abstract representation of existing conditions such as speed, altitude, or heat, in terms of knots, feet, or degrees. These displays need no pictorial resemblance to the conditions they represent.

**Pictorial displays:** Any instrument which simulates the actual visual observation of the event occurring is referred to as a pictorial display. Examples of symbolic and pictorial displays are illustrated at the right. (See Grether, 1947b)

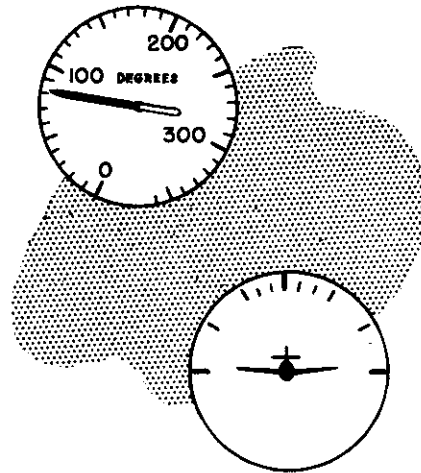

BASIC SYMBOLIC INDICATOR TYPES

There are three basic types of symbolic mechanical indicators which are most commonly used. These are:

Direct reading counter



Moving pointer with a fixed scale

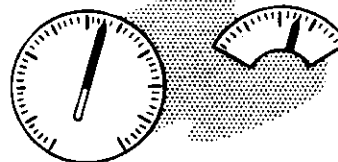

Moving scale with a fixed pointer

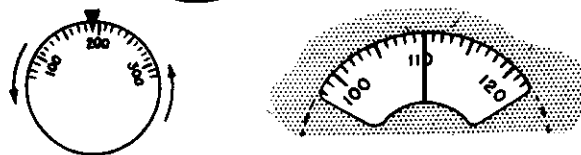

**Selection of a symbolic indicator type:** The selection of one of these various indicators depends upon the particular use to which the instrument is to be put. The following table lists the relative advantages and disadvantages of the three basic indicator types with reference to the method of use. It is apparent from the table that for general purposes the moving pointer offers the greatest number of advantages. The counter is best when purely quantitative readings are required. The counter and moving scale require less exposed area (opening in the panel) than the moving pointer.

TABLE OF RECOMMENDED INDICATORS ACCORDING TO USE

METHOD OF USE	MOVING POINTER	MOVING SCALE	COUNTER
1. Quantitative Reading.	Fair	Fair	Good Minimum time and error in obtaining exact numerical value.
2. Qualitative and Check Reading	Good Location of pointer easily detected. Numbers and scale need not be read. Change in position easily detected.	Poor Difficult to judge direction and magnitude of deviation without reading numbers and scale.	Poor Numbers must be read. Position changes not easily detected.
3. Setting	Good Simple and direct relation of pointer motion to motion of setting knob. Pointer position change aids monitoring.	Fair Somewhat ambiguous relation to motion of setting knob. No pointer position change to aid monitoring. Not readable during rapid setting.	Good Most accurate monitoring of numerical setting. Relation to motion of setting knob less direct than for moving pointer. Not readable during rapid setting.
4. Tracking	Good Pointer position readily monitored and controlled. Most simple relation to manual control motion.	Fair No pointer position changes to aid monitoring. Somewhat ambiguous relation to control motion. Not readable during rapid changes.	Poor No gross position changes to aid monitoring. Ambiguous relation to control motion. Not readable during rapid changes.
Comments	Requires greatest exposed and illuminated area on panel. Scale length limited unless multiple pointers are used.	Offers saving of panel space. Only small section of scale need be exposed and illuminated. Long scale possible by use of tape.	Most economical of space and illuminated area. Scale length limited only by number of counter drums.

**VARIATIONS IN BASIC INDICATOR TYPES**

**Circular and curved scales, moving pointer:** This design is generally recommended. The circular scale permits the maximum exposed scale length in a limited panel space. It provides for a compact instrument case. The long pointer and rotational movement aid in check and qualitative reading. The circular scale is preferred to the curved scale for most applications.

**Vertical and horizontal straight scales, moving pointer:** This design is not recommended for general use. It is less compact than circular scales. The shorter pointer and lack of angular movement are less favorable for check reading.

**Circular and curved scales, moving scale:** The use of a fully exposed scale is usually not necessary. The partially exposed scale is generally recommended. This permits a large range of values in a limited panel space. Overlapping the covered scale portions also saves panel space as illustrated in the diagram. Instruments used in tracking, such as magnetic heading indicators, should have the full scale exposed.

**Vertical and horizontal straight scales, moving scale:** A moving scale behind an open window may be a moving straight scale, drum, or tape. The moving tape is suitable for presenting a large range of values that are to be read quantitatively. Moving scale designs are, however, not recommended for general use.

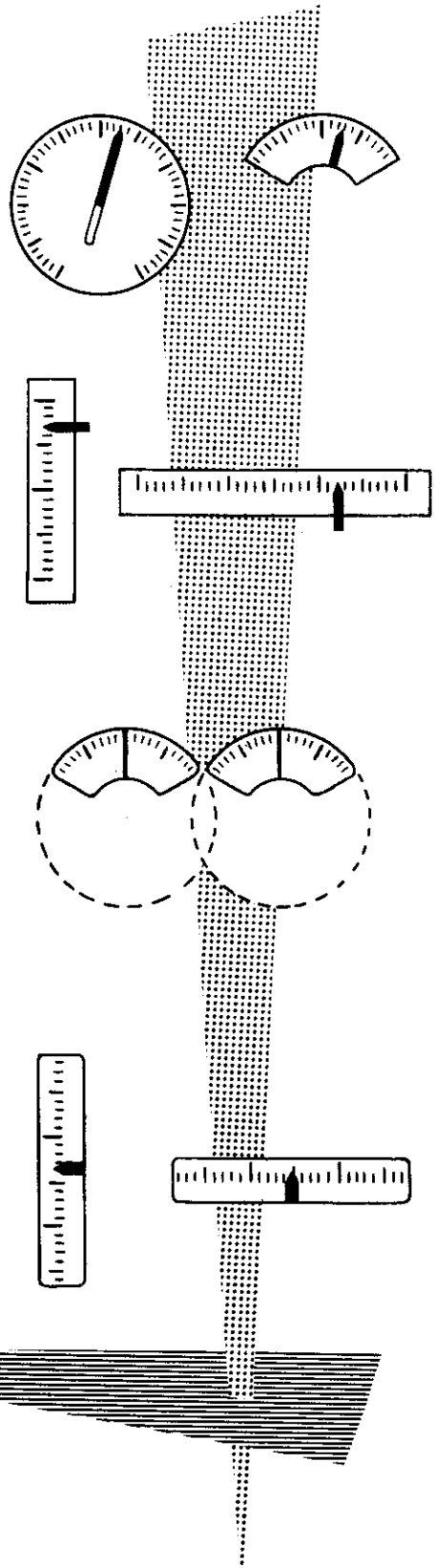

**LONG SCALE INDICATORS**

When a great range of values must be displayed on one instrument the conventional methods of presentation are usually inadequate. The presentation of altitude will illustrate the application of long scale instruments. We will assume the need for an altimeter with a range from zero to 70,000 feet. We will also assume that the operator requires reading precision that necessitates graduated intervals every 20 feet throughout the entire range. An indicator with a moving pointer and a fixed scale would require a scale length of about 245 inches to provide altitude information with this precision. The indication of time in hours, minutes, and seconds presents a similar problem. Several solutions to the problem of long scale indication are evaluated below.

**Multiple pointers:** There is one sensitive multirevolution pointer and one or more other pointers to give gross readings. The reader must mentally combine several separately indicated values. The probability of gross reading errors is high. (Grether, 1947a) This method of indication is acceptable for indicating time, but is not recommended for general use.

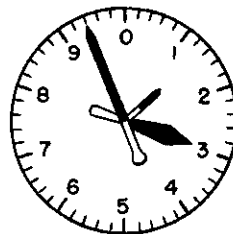

**Subdial:** When a limited scale range is to be presented, the indicator illustrated at the right is satisfactory, if for most purposes gross readings of the main pointer are adequate. The subdial is only used on those occasions requiring more precise readings. One revolution on the subdial should cover a range equal to a numbered interval on the main dial.

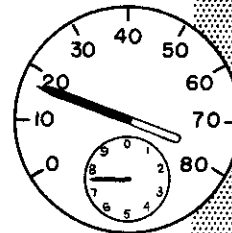

**Direct reading counter:** This is an excellent means of presenting a large range of quantitative values. It requires very little panel space. It is not satisfactory for qualitative reading or tracking. It is recommended when purely quantitative information is needed.



**Sensitive pointer-moving scale combination:** Not recommended. The error probability is high in combining these two indications.

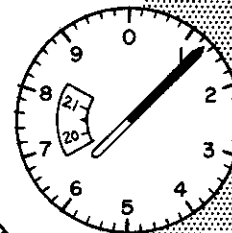

**Sensitive pointer-counter:** This is a generally recommended solution for long scale indicators for check and qualitative reading. It is slightly inferior to counters for purely quantitative reading. (Grether, 1947a)

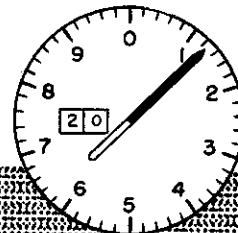

**SELECTION OF MECHANICAL PICTORIAL INDICATORS**

Purely pictorial indicators have limited value and are rarely used. (Grether, 1947b) The pictorial element is usually a simplified replica of the situation it depicts. In most cases the pictorial element is combined with symbolic quantitative indications. However, the addition of pictorial elements to symbolic indicators can be of considerable aid to their interpretation and use. Pictorial elements are usually limited to indicators which display information relative to positions in space. They may refer to components of the aircraft, the ground, or other outside references. Examples of pictorial types of indication are landing gear position, flap position, attitude, IAS cross pointer, rate of climb, and magnetic and radio compass.

**PICTORIAL REPRESENTATION OF AIRCRAFT ATTITUDE, DIRECTION, AND POSITION IN SPACE**

**Airplane reference vs. earth reference:** In the pictorial representation of the aircraft's position in space, two mutually contradictory frames of reference are possible. Movements of the indicator can represent movements of the horizon, radio beam, or magnetic flux lines relative to the aircraft. This is called an 'earth reference' type of indication. It is also called a 'fly to' indication since the pilot flies toward the moving element to neutralize a deviation. The alternate frame of reference is one in which the moving element simulates the movement of the aircraft relative to the earth or radio beam. This is called 'aircraft reference' or 'fly from'. In this presentation the operator flies from the indicating element to neutralize a deviation. The difference between these two principles of indication is illustrated in the following examples of pictorial indicators.

**Aircraft attitude - pitch and roll:** Aircraft attitude may be displayed on either a 'fly from' or 'fly to' orientation as illustrated below:

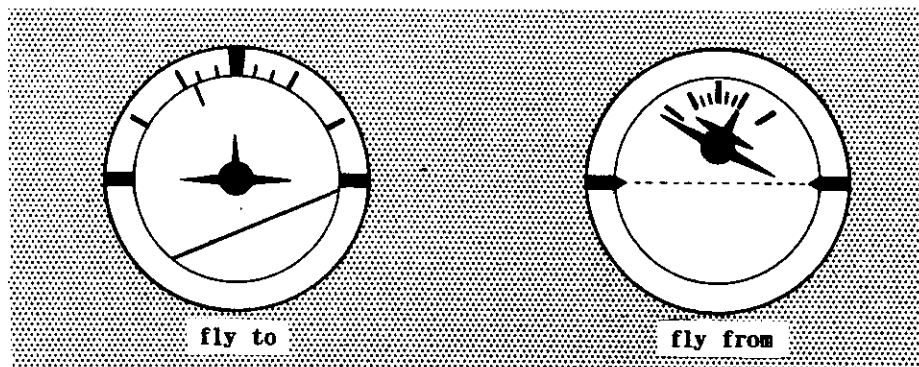

Both indicators show a right roll and nose up attitude. Both instruments are considered pictorial and are supplemented with quantitative scales. The airplane reference or 'fly from' type of indication is the easiest to learn to use and interpret. \* (Browne, 1945; Loucks, 1947; Gardner, 1954.)

\*Most current aircraft gyro horizon or attitude indicators are of the earth reference type and give a 'fly to' indication. A change in these instruments would cause a conflict with established reading habits of already trained pilots.

**Cross Pointer Indicator:** The cross pointer gives the pilot information concerning the relative amount and direction of error that exist between his desired flight path, defined by a radio beam, and his actual flight path. The horizontal pointer moves vertically to indicate whether the aircraft is above or below the desired flight path. The vertical pointer moves horizontally to indicate whether the aircraft is to be to the right or left of the desired flight path. Below are examples of earth reference and aircraft reference indicators.

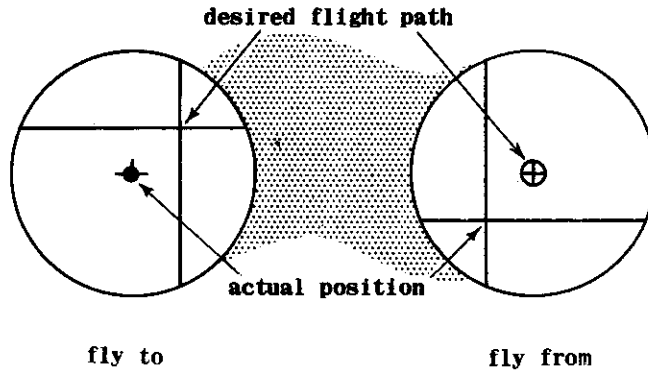

In both cases the aircraft is to the left and below the desired flight path. The aircraft reference or 'fly from' type of indication is the easiest to learn to use and interpret.\* (Loucks, 1949; Gardner, 1950.)

**Heading Indicators:** Most heading indicators are designed with either a fixed pointer (or lubber line) and a moving scale, or a moving pointer with a fixed or settable scale. In either case the entire scale should be exposed to aid selection of new headings.

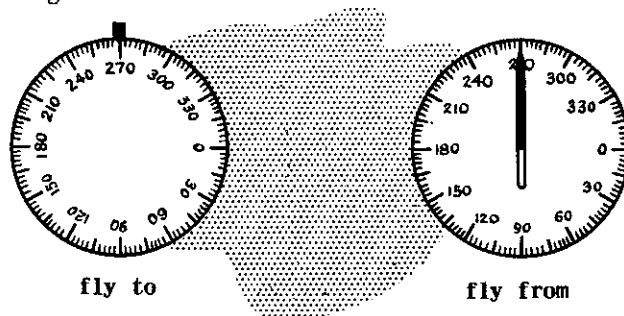

Most current Air Force heading indicators use a moving pointer combined with a settable dial for placing the desired heading at the top of the instrument. This arrangement permits a consistent aircraft-control-instrument movement relationship, and retains the inherent advantages of the moving pointer for check reading and tracking types of use. This arrangement does, however, require frequent resetting by the pilot. The rotating card type of heading indicator avoids this need for resetting.

\*Current ILAS cross pointers, flight path computers (zero readers), and omnirange indicators use the 'fly to' type of indication. A change in these instruments would cause a conflict with established reading habits of already trained pilots.

**Component position indicators:** Position or changes in position of aircraft components should be represented with the indicator as the fixed frame of reference. It is recommended that the location and action should have the same orientation as the instrumented components, as illustrated in the following example:

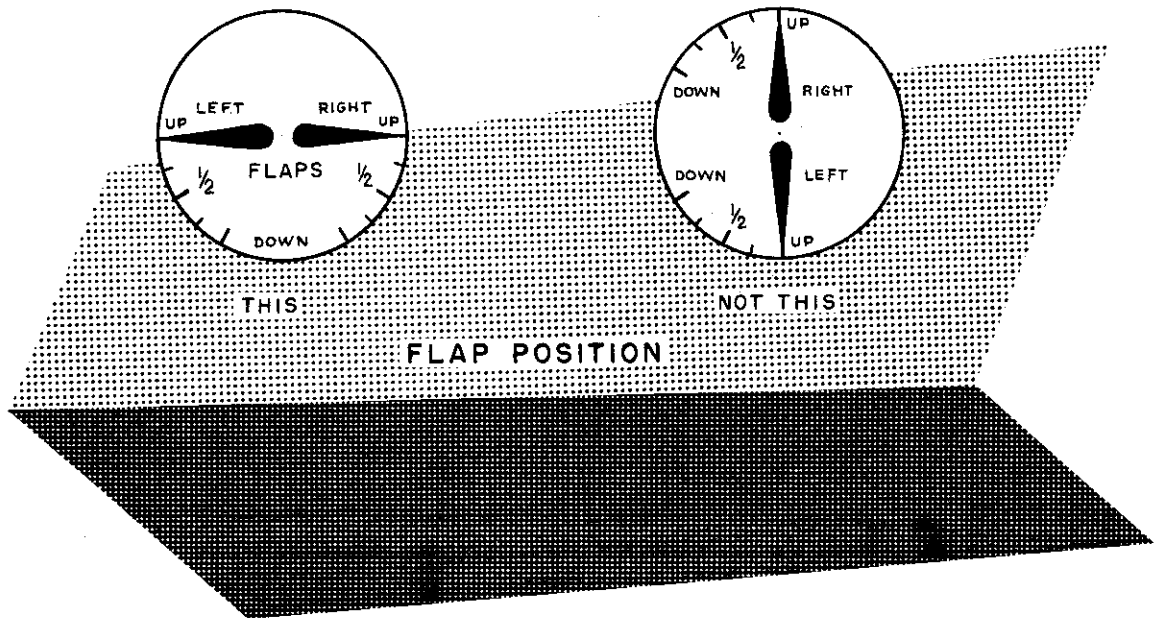

**DISTINCTION BETWEEN FLIGHT (TRACKING) AND NAVIGATION (ORIENTATION) DISPLAYS:** Pictorial indicators for representing direction and position in space can be separated into two types according to their primary method of use:

**Flight Instruments:** These are used for continuous control or tracking of the aircraft to maintain the desired flight conditions (examples: pitch, bank, heading). The best type of pictorial indicator for this purpose is the 'airplane reference' or 'fly from' type.

**Navigation Instruments:** These are used to maintain orientation in space in relation to ground references. Usage of the instrument is usually intermittent, and actions are in the nature of decisions rather than immediate control movements. Instruments of this type are the Radio Compass, (except when used for homing) the Radio Magnetic Indicator (combining two radio compass pointers with a moving scale indication of heading), and recently developed map-type ground position displays. For navigational or orientational purposes, either the 'earth reference' or 'airplane reference' principles may be satisfactory. In actual practice it is often difficult to judge whether an instrument is primarily a flight or an orientation instrument, nor is it always possible to make the 'earth vs. airplane reference' distinction. Also, in cases where pilots or other crew members are already habituated to a less desirable 'earth reference' indication, it may be unwise to make a change because of interference with well established instrument reading habits.

## GENERAL DESIGN RECOMMENDATIONS

There are several considerations that enter into the proper design of mechanical indicators. Some of these considerations deal with the direction of indicator motion. These are the direction of movement of the moving element in relation to (1) the numerical value being indicated, (2) the direction of the associated control movement, and (3) the direction of motion of the vehicle or component to which the instrument refers.

### MOVING POINTER AND FIXED SCALE INDICATORS: RECOMMENDATIONS

#### Circular scales:

Clockwise movement of the pointer should increase the magnitude of the reading.

In cases where positive and negative values around a zero value are being displayed the zero should be located at the nine or twelve o'clock position. The positive values should increase with clockwise movement of the pointer and the negative values increase with counterclockwise movement.

Clockwise movement of the pointer should result from (1) clockwise movement of the associated knob or crank, (2) movement forward, upward, or to the right of an associated lever, or (3) movement upward or to the right of the vehicle or component.

Except on multirevolution instruments, such as the clock, there should be a scale break between the two ends of the scale. ( Kappauf, 1951.)

For ease of check reading quantitative values ( engine instruments ) or for up-down orientation, the area of most frequent or critical reading should be located at the nine o'clock position on the dial face. ( Warrick and Grether, 1948; Kappauf and Smith, 1950; Kappauf, 1951.)

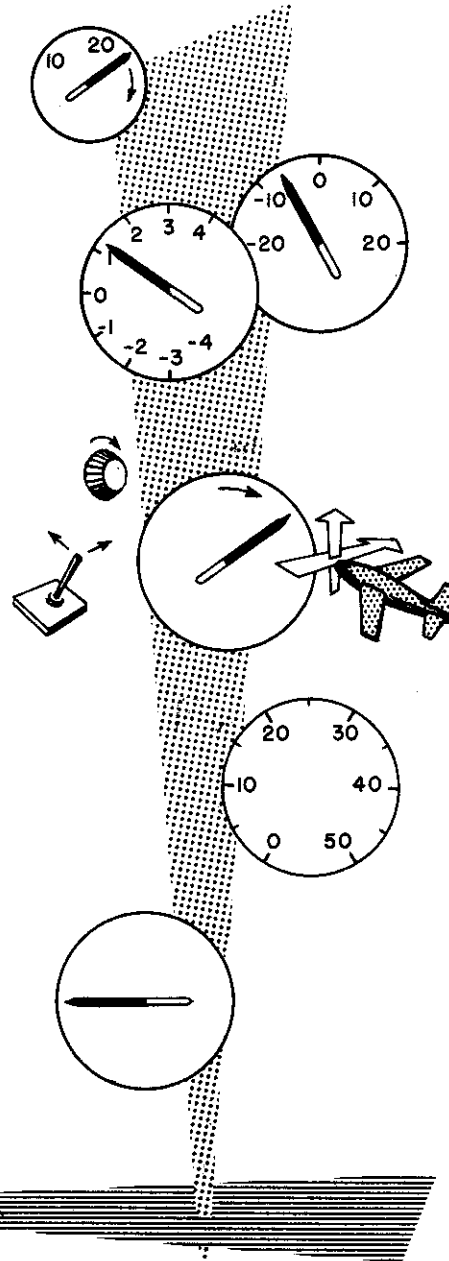



For ease of check reading bearing or course indication ( or other right-left information) the area of most frequent or critical reading should be located at the twelve o'clock position. This may be accomplished by having a dial face that can be rotated manually.

In general it is better to place the numerals inside of the graduation marks to avoid constriction of the scale and hiding of numbers by the bezel. If space is not limited the numbers may be placed outside of the marks to avoid having the numbers covered by the pointer.

**Vertical and Horizontal Straight Scales:**

The pointer should move up or to the right to indicate an increase in magnitude.

Movement of the pointer upward or to the right should result from (1) clockwise rotation of the associated knob or crank, (2) movement forward, upward, or to the right of a lever, or (3) movement upward or to the right of the vehicle or component.

The numbers should be located on the side of the graduation marks opposite the pointer. The graduation marks should be aligned on the side of the pointer and stepped on the side of the numbers.

It is recommended that the pointer be to the right of vertical scales and at the bottom of horizontal scales.

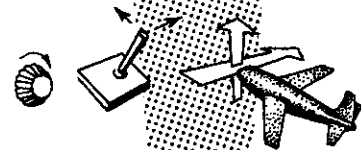
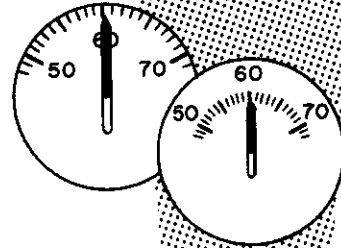
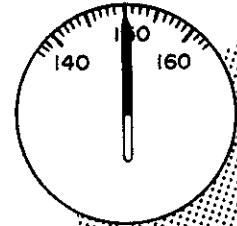

**MOVING SCALE AND FIXED POINTER INDICATORS**

**Circular scales:** There exist certain ambiguities with moving circular scales and the associated control movement. One of the following three recommended practices must be violated in the design of circular moving scales:

- (1) Scale numbers should increase in a clockwise direction around the dial. Values on moving circular scales, therefore, increase with counter-clockwise rotation of the dial face.
- (2) The direction of movement of the associated control should be compatible with the direction of movement of the dial. (Clockwise movement of the control should result in clockwise movement of the dial.)
- (3) Clockwise movement of a control should result in an increase in function.

If principle one above is compromised (numbers on the scale increase in a counterclockwise direction) operators tend to make final setting errors. If principle two above is compromised (clockwise movement of the control results in counter-clockwise movement of the dial) operators err in the initial direction of turn. (Bradley, 1954.) If principle three above is compromised a standardized control movement-system relationship is violated. The following recommended practices in the design and use of circular moving scales will minimize the effects of these incompatibilities.

The numbers should progress in magnitude in a clockwise direction around the dial face. Therefore, counterclockwise movement of the dial face increases the readings.

If the associated control has no direct effect on the behavior of the vehicle ( tuning in radio stations, monitoring electronic equipment ) the scale should rotate counterclockwise ( increase ) with counterclockwise movement of the associated knob or crank.

If the associated control has a direct effect on the behavior of the vehicle ( speed, direction, etc. ) the scale should rotate counterclockwise ( increase ) with (1) clockwise movement of the associated knob, wheel, or crank, (2) movement forward, upward, or to the right of a lever, or (3) movement forward, upward, or to the right of the vehicle or component. Because of these ambiguities it is recommended that a moving pointer indicator be used in preference to moving scale indicators for flight indications.

The pointer or lubber line position should be at twelve o'clock for right-left directional information, and at nine o'clock for up-down information. For purely quantitative information either position may be used.

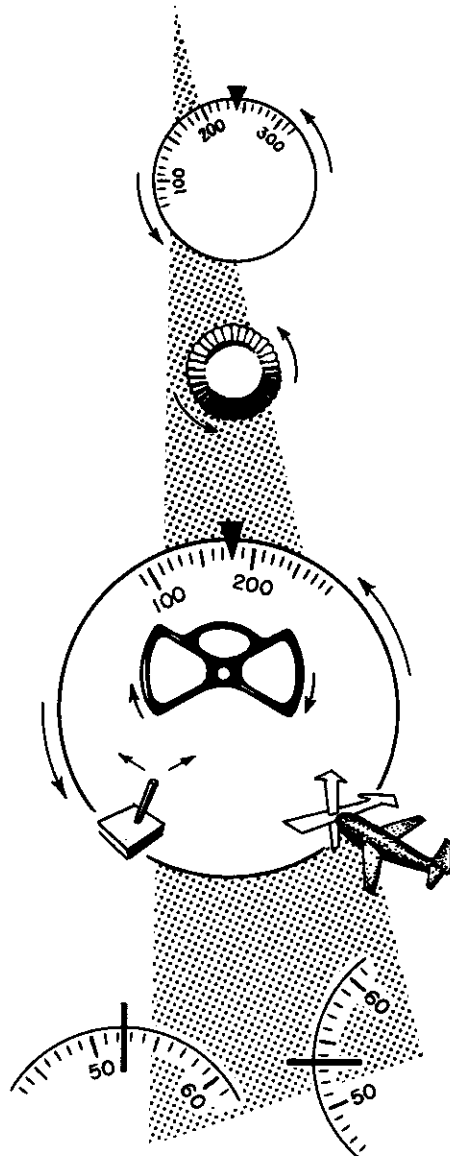

If the display is used for setting, such as tuning in a desired wavelength, it is usually advisable to cover the unused portion of the dial face. The open window should be large enough to permit at least one numbered graduation to appear at each side of any setting.

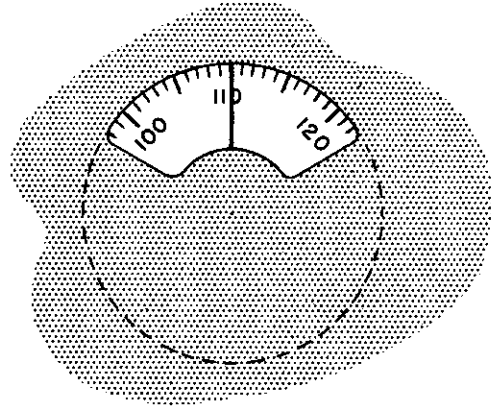

If the display is used in tracking, as in the case of heading indicators, the whole dial face should be exposed.

## Vertical and horizontal moving straight scales

The same direction-of-motion ambiguities exist as in circular moving scales. The numbers should increase from bottom to top or from left to right.

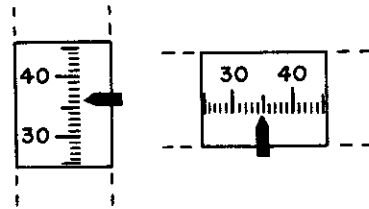

The scale should move down or to the left ( increase ) when (1) the associated knob or crank is moved clockwise, (2) when the associated lever is moved forward, upward, or to the right, or (3) the vehicle or component moves up or to the right.

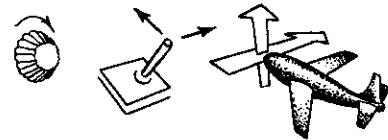

See also the recommendations for straight scales with moving pointers.

## COUNTER TYPE INDICATORS

The numbers should change by snap action in preference to continuous movement.

Clockwise rotation of a knob or crank should increase the counter indication.

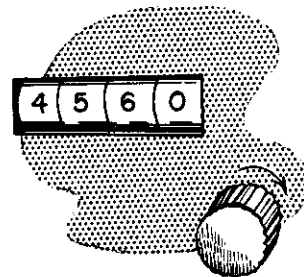

**SCALE DESIGN**

This section offers recommendations concerning design principles for scales used on mechanical indicators.

**DEFINITION OF TERMS**

**Scale range:** The numerical difference between the highest and lowest value represented on a scale.

**Numbered interval value:** The numerical difference between adjacent numbers on a scale.

**Graduation interval value:** The numerical difference represented by adjacent graduation marks.

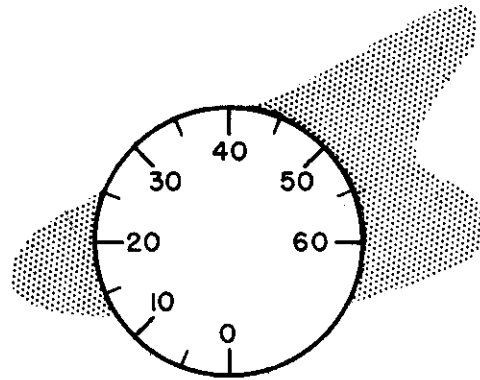

Scale range .....60  
Numbered interval value .....10  
Graduation interval value ..... 5

**SCALE NUMBERING AND GRADUATION INTERVAL VALUES:**

Some combinations of graduation interval values and scale numbering systems are more satisfactory than others. The recommendations below will assist in the selection of the most readable scales. (Vernon, 1946; Chapanis and Leyzorek, 1950.)

The graduation interval values should be 1, 2, or 5 or decimal multiples thereof; no other values are acceptable

Any scale should be represented as a part of a scale which starts at zero, with the numbered marks progressing by ones, twos, or fives, and with the appropriate number of zeros after each digit. Below are examples of good, fair, and poor numerical progressions for scale numbering.

**SCALE NUMERICAL PROGRESSION**

good	fair	poor
1 2 3 4 5	2 4 6 8 10	40 80 120 160
10 20 30 40	20 40 60 80	0 2.5 5 7.5
100 200 300	200 400 600	0 15 30 45
5 10 15 20		30 60 90 120*
50 100 150		0 60 120 180

\* See page 17 for special application of this numerical progression.

The numbered graduation marks should be major graduation marks. See page 18.

The number of graduation marks between numbered graduation marks should not exceed nine, i.e., ten graduation intervals.

**Scale selection:** Before a designer selects a scale for a mechanical indicator he should decide on the appropriate scale range and should study the operator's task to estimate the precision required of the instrument reading. In this connection, the designer should keep in mind the second item of the check list on page 2. The scale should be designed to be read as accurately as demanded by the operator's needs, and preferably no more accurately. With this information in mind the designer may select from the table on the next page the most suitable scale. For special cases, such as logarithmic scales and long range scales, consult the pages following the table.

It is generally recommended that scales be designed so that interpolation between graduation marks is not necessary. However, when space is limited it is better to require interpolated readings than to clutter the dial with crowded graduation marks. (See page 19.) Assuming sufficient space, a scale that is to be read to the nearest 1, 10, or 100 pounds of pressure should be selected from those scales on the following table with graduation interval values of 1, 10, or 100. If accuracy to the nearest .5, 5, or 50 units or .2, 2, or 20 units is required, scales with the appropriate graduation interval values should be selected.

In general it may be said that scales numbered by intervals of 1, 10, 100, etc. and subdivided by ten graduation intervals are superior to other acceptable scales.

**Poor scales:** The scales illustrated below have been constructed with one or more violations of the previously listed design recommendations. Scales like these are difficult to read and should not be used.

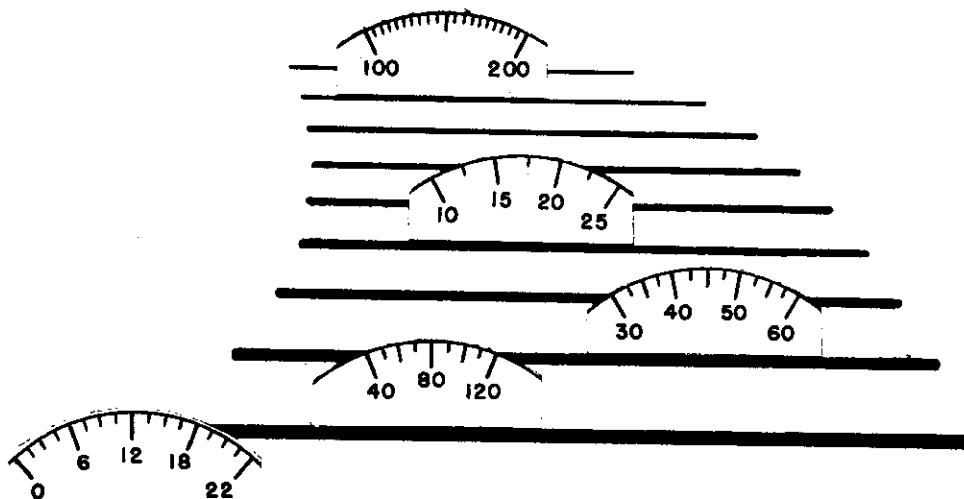

TABLE OF RECOMMENDED SCALE DESIGNS

Graduation Interval Value	Recommended Scales	Numbered Interval Value	Graduation Marks Used		
			Major	Minor	Intermediate
.1, 1, 10.		1, 10, 100.	X	X	X
		5, 50, 500.	X	X	
		2, 20, 200.	X		X
.2, 2, 20.		1, 10, 100.	X	X	
		2, 20, 200.	X	X	X
.5, 5, 50.		1, 10, 100.	X		X
		2, 20, 200.	X	X	X
		5, 50, 500.	X	X	X

EXCEPTIONS TO SCALE PRINCIPLES

It is acceptable to deviate from the previously listed scale design principles when other primary considerations must be met. Certain unique applications of scales require other design features, and compromises with the principles listed above must be made.

**Heading indicators:** The heading indicator to the right violates our recommendations inasmuch as the numerical progression of 30, 60, 90, etc. is less satisfactory than those recommended. This represents a compromise between the best numbering progression and a manageable size of dial. The heading indicator is a small dial and since the numbered cardinal points (north, east, south, and west) serve as anchoring points in the interpretation of this indication, a progression by 30's appears a good solution. When the dial can be made large enough, the major intervals should be marked by 10's. Examples of such usages are the bearing dials surrounding many types of radar scopes.

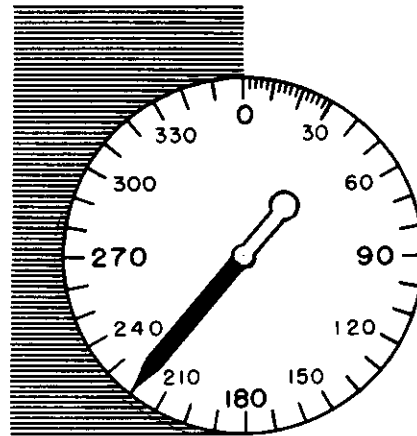

**Nonlinear scales:** Nonlinear scales condense a large range into a relatively small space and yet permit sensitive readings at certain critical ranges of the scale. In situations where error tolerances are a constant percentage of the indication, a logarithmic scale is very suitable. However, logarithmic scales should contain as many numbered graduation marks as possible, to minimize errors as a result of linear reading habits. The scale to the right illustrates such a scale.

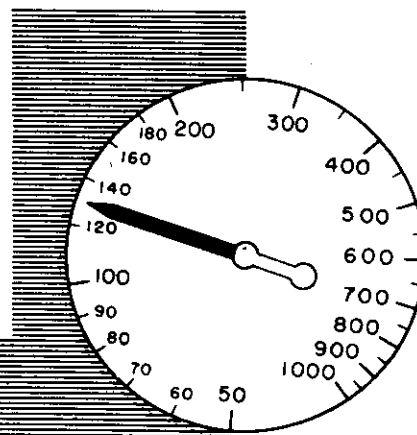

**mechanical indicators  
scale design**

**TRANSFORMED SCALE VALUES:** Any display, if possible, should provide the information in an immediately useful form. The operator should not be required to make mental conversions of the indicated values in order to make them useful.

Jet aircraft engine tachometers are now calibrated in percent RPM rather than actual RPM. This has several advantages. Maximum RPM differs for different engine models and types. The transformation of the scale values into percent relieves the pilot of the need for remembering operating RPM values for different engines. The range from 0 to 100 percent is more easily interpreted than would be a range of true values, such as 0 to 8,000 RPM. Also, the smaller numbers or the lack of scale number multipliers on the dial make a more readable scale. This is evident by observation of the two tachometers illustrated at the right.

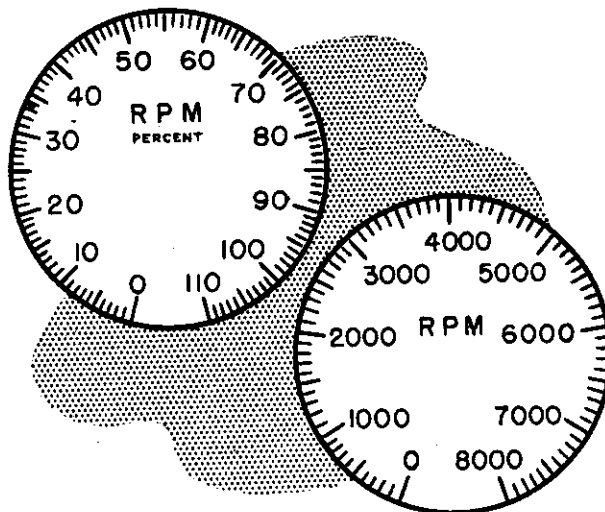

**SCALE DIMENSIONS - LOW BRIGHTNESS REQUIREMENTS:** The following recommendations apply to instruments in which the primary requirements are for accurate and rapid reading under a wide range of illumination conditions. For example, in aircraft the instruments are read over brightnesses from daylight levels to low brightness lighting levels (as low as .003 foot-lamberts) at night. A reading distance of 28 inches is assumed. For other reading distances (x) the recommended scale dimensions should be multiplied by x/28.

**Graduation mark dimensions:** Although the values in the following diagram of recommended graduation mark dimensions will apply to many aircraft instruments, they are not to be considered as fixed values that apply to all aircraft instruments. Factors such as scale size and number of graduation marks, and importance of the indication will have to be considered. Instead, these recommended dimensions should be used as models for the relative dimensions of major, minor, and intermediate graduation marks.

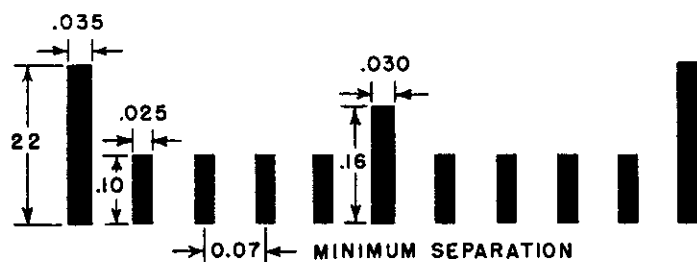

**Graduation mark spacing:** The absolute distance between adjacent graduation marks should not be less than .07 inches. This distance is measured from the graduation mark midpoints. (White and Sauer, 1954.)



**GRADUATION MARK DIMENSIONS - LOW BRIGHTNESS NOT REQUIRED:** The following recommendations apply to instruments that are reasonably well illuminated such as navigation and monitoring instruments operated by personnel not requiring dark adaptation. Assuming high contrast between the graduation marks and scale surface, illumination on the scaled surface above one footcandle, and more time to read indications than one normally has in the cockpit, the following recommendations apply:

The graduation marks may be smaller than those recommended on the previous page but the same general proportions should be maintained.

The separation between graduation marks should not be less than .035 inches.

When the graduation mark separation is less than .07 inches, the graduation mark thickness should be about 25% of the graduation mark separation distance.

**SCALE INTERPOLATION:** In general it is recommended that scales that are to be read quantitatively be designed so that interpolated readings between graduation marks is not necessary. Scales should be designed to be read to the nearest graduation mark. If we assume a scale range of 50 that is to be read to the nearest unit, the preferred scale would be numbered by tens with a graduation mark for each unit as in the example below.



However, if one is limited by space the scale may have to be designed so that interpolation is necessary. If the space available for the scale mentioned above is restricted to two inches the same scale would appear as follows:

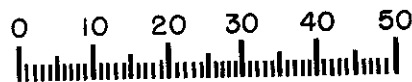

The graduation marks on this scale are too crowded to be read accurately and rapidly under low illumination. The midpoints are .04" apart. This is .03" less than the recommended minimum for cockpit instruments. In situations such as this one must then design a scale in which interpolation is necessary. A satisfactory solution is shown below.

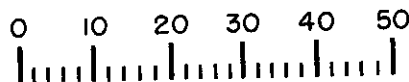

This scale has a graduation mark spacing of .08 inches, which is acceptable. Also, this scale requires only a simple interpolation of one unit between graduation marks. When space is greatly limited it may be necessary to interpolate in fifths, or even tenths. However, interpolation in tenths can be used only if errors as large as 10% of the interval can be tolerated in 50% of the readings. (Grether, 1947c)

**ADDITIONAL RECOMMENDATIONS**

Do not present more information on a scale than is usable by the operator. Below are examples of different levels of scale complexity. Select the least complex scale that fulfills the needs of the operator.

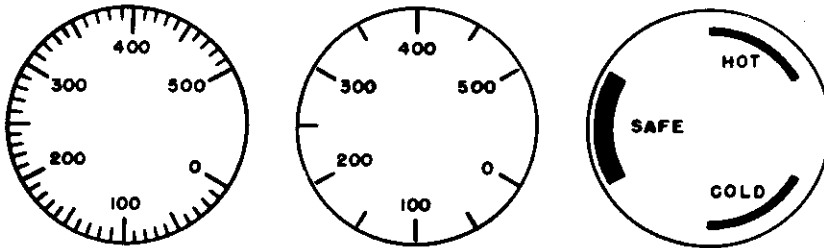

When the scale has a break, the zero location should be at the bottom of the scale. However, when pointer alignment is desired (See page 65) the zero or starting value should be positioned so that the desired value is located at the nine o'clock position.

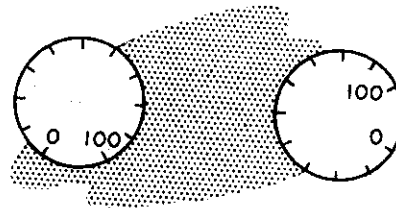

The zero location on multirevolution indicators should be at the top of the scale to conform with habits in reading conventional clocks.

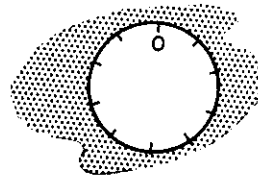

It must be remembered that on circular scales the numbers increase in a clockwise direction, on vertical scales from bottom to top, and on horizontal scales from left to right.

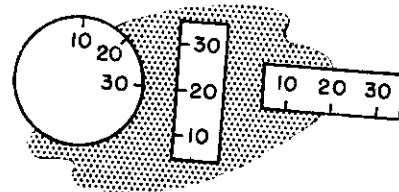

**INSTRUMENT ZONE MARKINGS**

On many aircraft instruments, zone markings are employed to indicate the various zones of operating conditions. These markings are usually placed on the instrument windows in preference to permanent placement on the dial face because of the frequent need for relocation of these markings as a result of varying engine maintenance and structural conditions of the aircraft. The zone markings can be coded to convey such information as (1) desirable operating range, (2) danger - lower limit, (3) danger - upper limit, (4) caution, (5) dangerous vibration, (6) undesirable - inefficient, etc.

**CODING METHODS**

**Color coding:** The table below shows the recommended operating conditions to be associated with various colors of zone markings. The diagram below illustrates how color coded zone markings can be used. Color coding should not be used if the instrument is illuminated with a colored light source such as red lighting because colors are not distinguishable when illuminated by colored sources.

Color	Condition
red.....	danger
yellow.....	caution
green.....	desirable - auto rich
blue.....	desirable - auto lean
no marking.....	inefficient

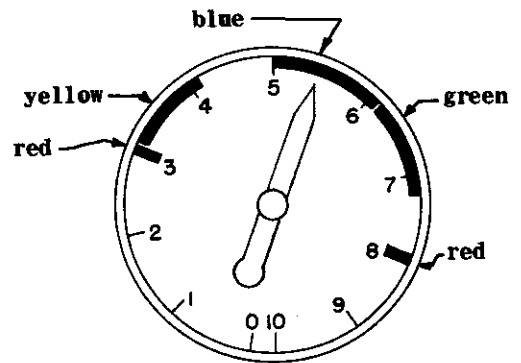

**Shape coding:** The shape or configuration of the zone markings can be coded to indicate various operating conditions. The shapes illustrated below are recommended because (1) they are easily learned associations, (2) they are distinguishable under low illumination, and (3) they are distinguishable under any color of illumination. (Sabeh, Jorve, and Vanderplas, In preparation.)

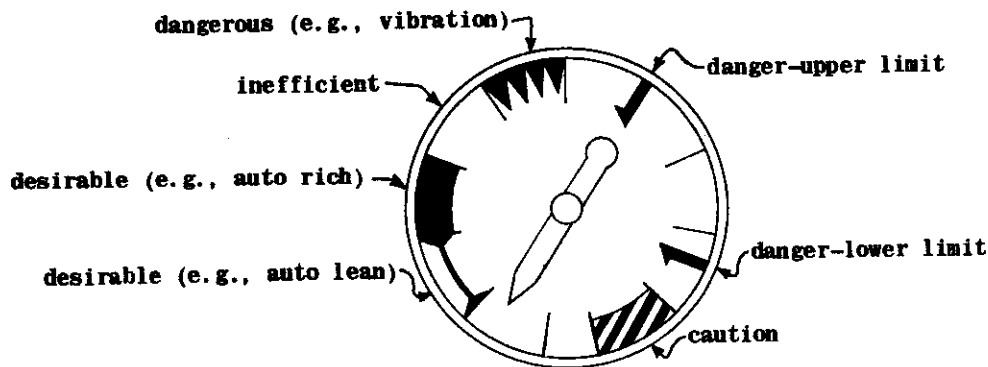

POINTER DESIGN

The pointer should extend so that the point will just meet, but not overlap, the shortest graduation mark.

The pointer tip should be as close as possible to the dial face, to minimize parallax.

For most applications the pointer section from the center of rotation to the point should be painted the same color as the dial markings. The balancing portion of the pointer should be painted the same color as the dial background.

For engine instruments, designed for horizontal pointer alignment, the contrasting portion of the pointer should extend beyond the center of rotation by an amount equal to about one half of the pointer radius. (White, 1951.)

In cases where reciprocal readings are required ( heading indicators ), the contrasting portion of the pointer should extend beyond the center of rotation by an amount equal to about three fourths of the pointer radius. The reciprocal end should be blunt rather than pointed to avoid confusion with the pointer tip.

The recommended pointer style for aircraft instruments is illustrated in the diagram.

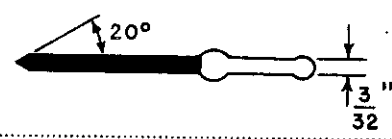
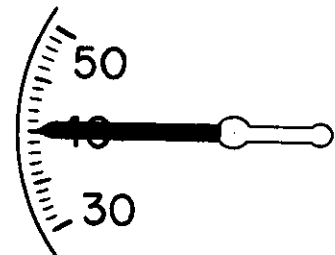
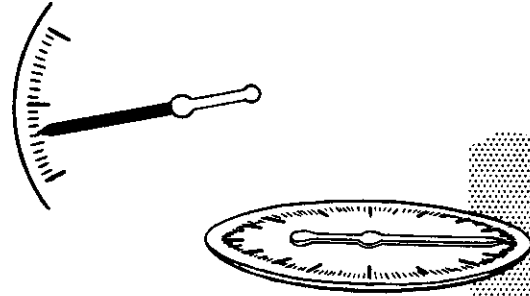

**INSTRUMENT IDENTIFICATION**

It is important that the operator have as many cues as possible to identify instruments. Identification may be assisted by name plate labels, position, size, shape, color, and the unique configuration of the particular instrument. Size and total configuration assist identification, but these cues result from other considerations that are not primarily concerned with identification.

**Instrument Labeling:** Instruments should be labeled in the most simple and direct manner possible. The following apply to instrument labeling.

It is usually best to label the instruments in terms of what is being measured and not by the name of the instrument.

Altitude	Not	Altimeter
RPM	Not	Tachometer
Acceleration	Not	Accelerometer

Make labels as brief as possible, but do not abbreviate words unless the abbreviated form is familiar to the operators.

Climb	Not	Rate of Climb
RPM	Not	Revolutions per minute
Man. Press.	Not	MP

Position the label so that the numerical designations or graduation marks are not crowded or occluded. In a circular fixed scale display, the center of the dial face is usually the most appropriate location for the label.

Company trade names or labels should not appear on the visible portions of the display.

**Instrument Color Coding:** It is possible to use different schemes for various instruments to assist in identification. However, aircraft instruments are illuminated by red light at night and under these conditions colors become much less discriminable. It is recommended that if instruments have to be read at any time under an illuminant other than white, color coding should not be used.

**Instrument Shape Coding:** The research on shape coding has been inconclusive. It is not recommended that shape coding be attempted at this time.

**Position Coding:** One of the best means to assist instrument identification is to maintain consistent instrument positioning among various craft. This topic is handled under instrument panel arrangement.

**Instrument Configuration:** The standardization of instruments serving the same function will assist identification from one craft to another. It has also been suggested that all instruments be reduced to common scales in an effort to maintain consistent scale reading habits. This may, however, destroy the most valuable cue of unique configuration of particular instruments. Until more data are available, it is definitely not recommended that various instruments be reduced to common scales.

**mechanical indicators  
numerals and letters**

**NUMERALS AND LETTERS**

The numerals and letters on instrument dials, panels, and consoles should be designed to afford maximum legibility for all conditions of use. In the aircraft the space restrictions and wide range of illumination levels must be considered. The following recommendations apply to general flood illuminated, indirect illuminated, and transilluminated numerals and letters.

**NUMERAL STYLE**

The numeral style shown on page 102 (Atkinson, Crumley, and Willis, 1952) is preferred. The AND 10400 numerals shown on page 101 and other numerals of the same simple style are also acceptable.

The width of the numerals should be 3/5 of the height except the '4', which should be one stroke width wider and the '1', which is one stroke width.

The stroke width should be from 1/6 to 1/8 of the numeral height.

**LETTER STYLE**

All letters should be capitals in preference to lower case. The AND 10400 letters (See page 101) or those recommended by NAMEL (Brown, 1953) are satisfactory. However, commercial types may also be used if they are of the same simple style.

The width of the letters should be 3/5 of the letter height except for the 'i', which is one stroke width, and the 'm' and 'w', which should be about 20% wider than the other letters.

The stroke width should be from 1/6 to 1/8 of the letter height.

**NUMERAL AND LETTER SIZE**

The table below gives recommended numeral and letter heights for a 28 inch viewing distance. For other viewing distances multiply the given values by distance in inches /28.

Nature of Markings	Height of Numerals and Letters in Inches ( 28 inch viewing distance )	
	Low Brightness (Down to .03 ft.-L)	High Brightness (Down to 1.0 ft.L)
Critical markings, position variable. ( Numerals on counters and settable or moving scales.)	.20 to .30	.12 to .20
Critical markings, position fixed. ( Numerals on fixed scales, control and switch markings, emergency instructions.)	.15 to .30	.10 to .20
Non-critical markings. ( Instrument identification labels, routine instruc- tions, any markings required only for initial familiarization.)	.05 to .20	.05 to .20

# Contrails

## chapter 2

### warning devices

It is frequently desirable to supplement conventional displays with warning, caution, and on-off indications. Such indications can be displayed by means of lights, electro-mechanical means, or both. The design recommendations for these indications follow.

#### WARNING LIGHTS

Warning lights are defined as those lights which serve as attention-getting devices to alert the operator to some existing dangerous condition requiring immediate attention. Warning lights should not be used for denoting routine or minor deviations from normal operation. Also, they should not be used for indicating malfunctions which require attention but do not necessarily require immediate action. (See caution signals.)

**Location:** The effectiveness of warning lights as attention-getting devices decreases with distance from the center of the visual field. For critical functions (killer warnings) the warning light should be within  $30^{\circ}$  of the normal line of sight. In addition it is desirable to have the warning light integral with or adjacent to the function lever, switch, or other control device by which the operator is to take action.

**Color:** All warning lights should be red to take advantage of the association value of this color with dangerous indications.

**Brightness:** Warning lights should be at least as bright as the brightest source on the panel, and several times as bright as the background against which they appear. Warning lights should not be so bright as to dazzle the operator. Two brightnesses should be used, one for daylight and one for night. The selection of brightnesses may be tied in with the instrument panel light switch.

**Identification:** It is important that the warning lights indicate the nature of the hazardous condition immediately in order to facilitate appropriate action. An illuminated identification label should appear simultaneously with and immediately adjacent to the warning light. When feasible, the warning light should be located on the appropriate control to assist in identification. See diagram below.

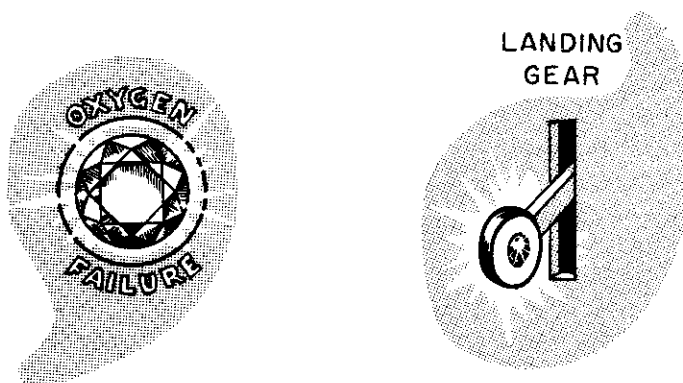

**Intermittent Light:** An intermittent light is considered somewhat more effective than a steady light, but is not generally recommended since it is more disturbing to the operator. If used, a rate of four flashes per second is recommended, with equal time for the light and dark intervals.

**CAUTION INDICATIONS**

Caution indicators are defined as those indicators which serve to alert the operator to an impending dangerous condition requiring attention, but not necessarily immediate action. Caution indicators should not be used to denote minor or routine deviations from normal.

**Master caution light - auxilliary panel:** A caution indicator system should incorporate a single red light as an attention-getting device, and an auxilliary panel to indicate the nature of the malfunction. The labeled auxilliary panel indicators may have illuminated flag type signals and transilluminated legends as shown in the diagram below. The master caution light should be located on the instrument panel where it will not be confused with warning lights. The brightness of the caution light should be the same as that for the warning lights.

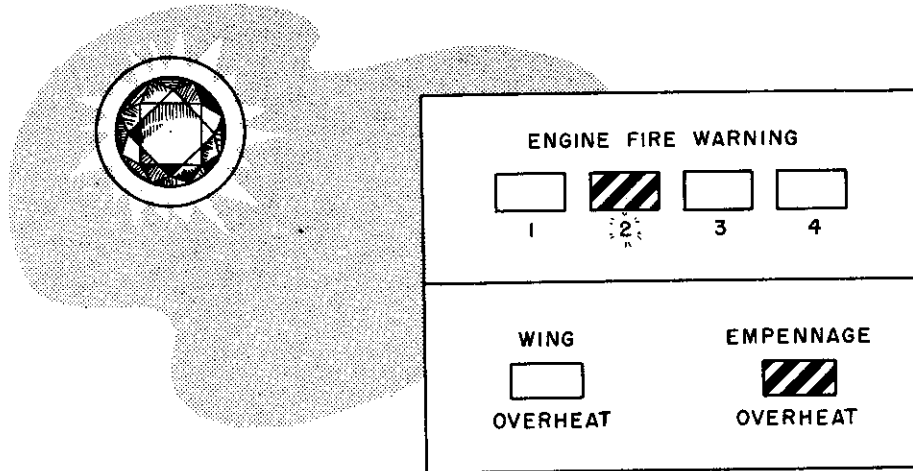

**ON-OFF INDICATORS**

On-off indicators are defined as those indicators in which the 'on' or 'off' position of the indicator denotes the operating condition of some function. In many instances such indications are superfluous, and they should be kept at a minimum. However, in some situations it is desirable to indicate by a positive signal that some component of a system is in operation, or that it is not in operation, so that the operator can react accordingly. It is recommended that mechanical or electro-mechanical indications be used as illustrated below.

Inoperative or caged instruments should be clearly identified as such if mechanical or electronic detection of the failure is possible. The operator may be alerted to such events by means of a flag or shutter that moves into view over the instrument face when the instrument is caged or inoperative due to some failure.

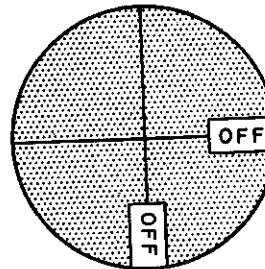



## chapter 3

# cathode ray tubes & signal coding

### INTRODUCTION

Cathode ray tubes (CRT's) provide a convenient means of presenting many types of information visually. The most common military applications are in various types of radar displays used for tactical evaluation, fire direction, air traffic control, navigation, and bombing. Another common use is in electronic test and monitoring instruments. This chapter is concerned primarily with the use of CRT's for displaying radar data. However, many of the recommendations will apply to plotting boards and other similar displays used in air defense centers, combat information centers, etc.

### DEFINITION OF TERMS

**Target:** An operationally significant object in space that reflects radio energy.

**Signal:** Those lighted areas on the tube face which indicate the presence of objects in space capable of reflecting radio energy. Other terms which are frequently used by radar operators and radar engineers to refer to signals are radar echo, image, blip, and pip.

**Trace:** The lighted area which persists and decays with time after the displayed signal has moved elsewhere. Trace gives target history.

**Noise:** Those lighted areas on the tube face that do not represent reflecting objects in space. Noise is usually random and usually appears as bright spots which change in location from sweep to sweep.

**Clutter:** Signal returns from nonoperationally significant objects such as clouds, the sea, etc.

**Background:** That portion of the scope that includes noise and clutter, but no actual signal.

**Surround:** The area immediately adjacent to the scope face which is visible to the operator while viewing the scope.

**Brightness contrast:** The difference in brightness between two objects expressed as the ratio of the brightness difference to the greater brightness. As applied to CRT displays, brightness contrast usually refers to the contrast between the signal and the background.

**Scan line:** The sweep line that is synchronized with the antenna sweep. The phosphor is excited by potential changes along the scan line.

### COMMON TYPES OF RADAR PRESENTATION

**A-Scan:** The signal is deflected vertically from the horizontal sweep path when a return is received. The distance from the start of the sweep to the signal is an indication of the range of the reflecting object. The magnitudes of the vertical deflections indicate the relative strengths of the signals.

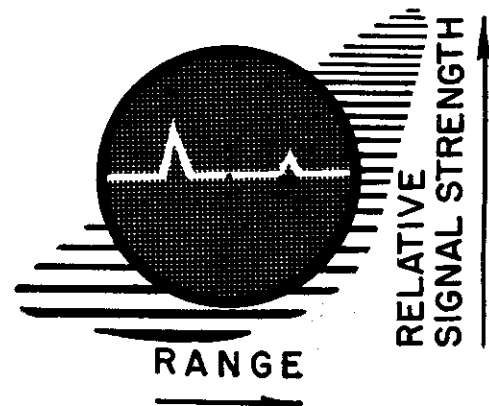

**cathode ray tubes  
general types**

**B-Scan:** A type of radar indication in which the azimuth is presented as a horizontal deflection of the cathode ray beam and the range is presented as a vertical deflection. The vertical scanning begins as the pulse is transmitted. When a signal returns, its azimuth and range can be read from the display. A disadvantage is the spatial distortion that results from this type of coordinate display. The distortion makes scope interpretation difficult. (Van Saun, 1946)

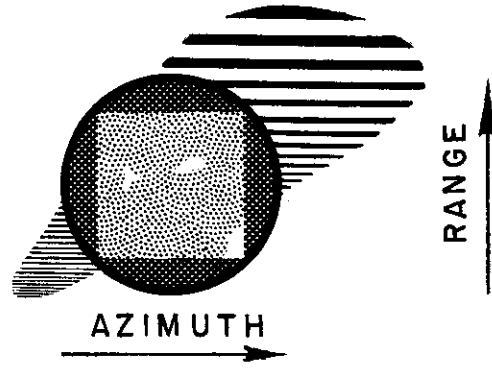

**C-Scan:** An indicator similar to the B-scan. However, the vertical axis displays altitude instead of range.



**F-Scan:** A radar indicator in which azimuth error is plotted horizontally and elevation error is plotted vertically. Cross hairs on the scope face assist in bringing the system to bear on the target.

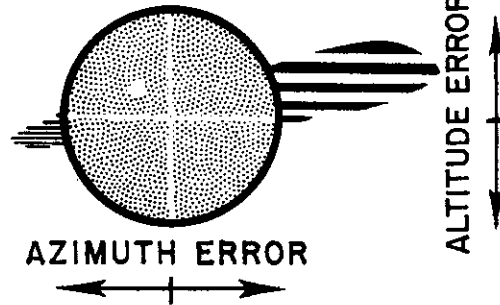

**PPI-Scan:** The plan-position-indicator plots range and azimuth in polar coordinates. The signal appears as a spot at a radial distance from the center of the display proportional to range. The position of the signal with respect to the angular location of the scan line corresponds to the azimuth of the target. The intensity of the signal corresponds roughly to the strength of the return.

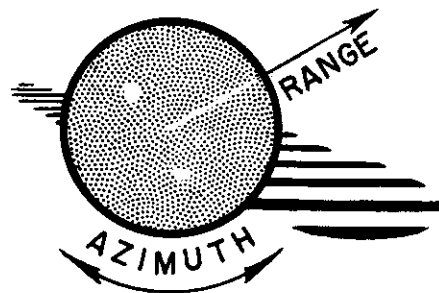

**Sector scan:** A sector of the PPI may be scanned for the purpose of concentrating search or tracking in one enlarged portion of the display.

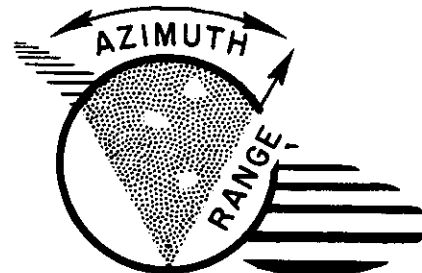

**CHECK LIST FOR GOOD DESIGN PRACTICES IN CATHODE RAY TUBES**

The display should resolve as much detail as is required for adequate interpretation of the displayed information. See page 29.

The brightness contrast relationship between the signal and background should be sufficiently high to afford good visibility. See pages 30-35.

The viewing distance should be such that visual fatigue is minimized, and the viewing angle, i.e., the angle between the tube face and normal line of sight, should be such that visibility is maximized. See page 35.

The ambient illumination in the CRT area should be sufficiently high for other visual functions (setting controls, reading instruments, maintenance, etc.) but should not interfere with the visibility of the signals on the CRT display. See pages 37-39.

The design of scales and other devices used to get quantitative data from the display should be such as to maximize accuracy and speed. See pages 40-45.

If information is to be coded, the coding methods used should provide a display that is easily interpreted. See pages 46-55.

**CATHODE RAY TUBE RESOLUTION**

A major difficulty encountered in interpreting CRT displays arises from the fact that they present an indistinct picture of the objects in space. This lack of distinctness, or definition, arises from a definite limitation in the resolving power of the radar. The amount of detail that may be displayed is roughly proportional to the resolving power of the radar system. If the resolution is poor, a ground target, such as a lake or river, may not be seen on the display, or separate buildings may be seen as one signal. This lack of detailed representation makes scope interpretation and target identification difficult.

There are many electronic variables that affect CRT resolution. The ways in which a CRT is affected by changes in beam width, pulse length, spot size, etc., are well known. (Radar Intelligence, 1945.)

**EYE VERSUS RADAR RESOLUTION**

It is possible to compare the resolving power of a radar system with that of the eye. The resolving power (visual acuity) of the eye for various conditions of seeing is discussed on page 87 and following. These data apply generally to the capabilities of an operator to see detail displayed on a radar scope. Under good viewing conditions the eye is capable of resolving detail which subtends a visual angle of less than one minute of arc.

Radar 'acuity' can be defined in the same manner as visual acuity. Namely, the resolution of a radar system may be expressed as the minimum angle subtended at the radar antenna by two point reflectors that are displayed as two signals. A radar system with a beam width of  $2^\circ$  is unable to resolve detail subtending less than  $2^\circ$  at the antenna. (See Radar Intelligence, 1945) In the examples cited the eye is capable of resolving detail 120 times smaller than the minimum size detail resolved by the radar system. The degree to which scope interpretation would be improved by increased resolution is not fully understood. However, it is generally believed that the most important variable in scope intelligibility is one involving target resolution.

### CATHODE RAY TUBE VISIBILITY

Although the term visibility has a more general meaning in visual science, we shall restrict its meaning in this section to refer to the detection of a signal on a CRT screen. We do not include under the problems of visibility such things as identification and classification of a signal. Visibility problems are, therefore, restricted to a few particular uses of radar systems, i.e., to those situations where large areas are scanned to detect the presence of relatively small targets such as those in air search and sea search radar. Problems of visibility are not prominent when radar systems are used for bombing and navigation. In such usages, large land areas are usually scanned and the problem is chiefly one of scope resolution.

#### VISUAL FACTORS IN VISIBILITY

The visibility, or probability of detection, of cathode ray tube signals depends upon five visual factors:

- (1) The size, in visual angle, of the pip or signal.
- (2) The brightness of the background, including noise and clutter.
- (3) The brightness of the pip.
- (4) The length of time the signal is present.
- (5) The state of adaptation of the eye.

#### SIGNAL SIZE AND BRIGHTNESS RELATIONSHIPS

The graph below shows the signal-to-background contrast required for 99% probability of detection for:

- (1) Signals of various sizes stated in visual angle. (See page 72)
- (2) Various background brightnesses. (Contrast is defined on page 72)

These data apply to situations where:

- (1) The operator is adapted to the brightness level of the task.
- (2) The signal is either brighter or darker than the background.
- (3) The background brightness (noise) is distributed evenly.
- (4) The operator has several seconds to detect the signal and is alerted to the task.

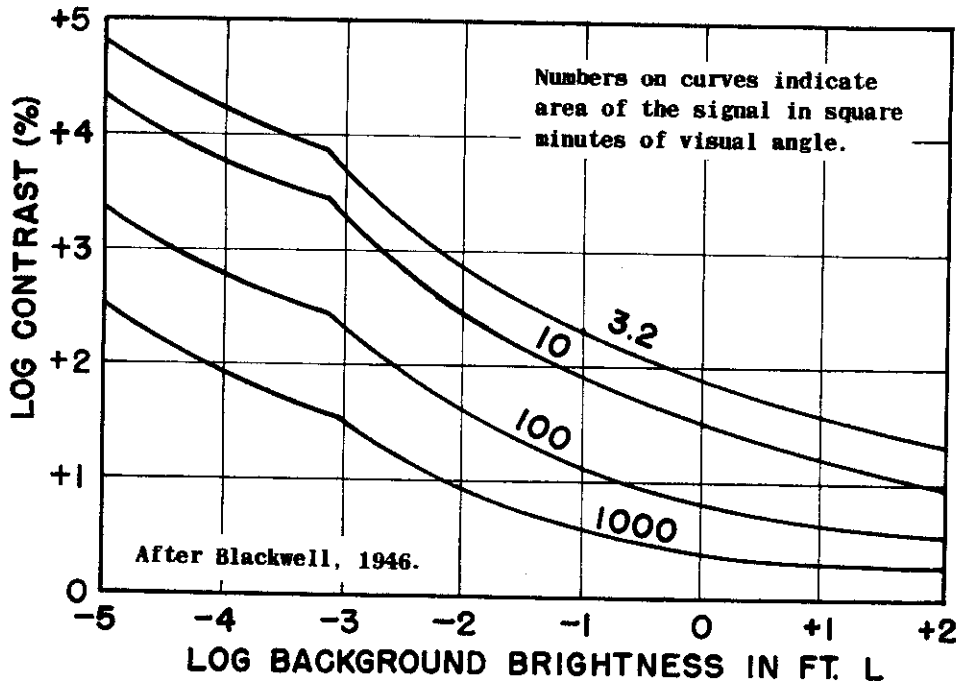

The graph reveals:

- (1) With larger signals the brightness contrast may be less and still maintain the 99% probability of detection.
- (2) With brighter backgrounds the contrast may be lower and still maintain the 99% probability of detection. However, the absolute brightness increment (or decrement) must be greater with higher background brightnesses.

#### DESIGN FACTORS THAT AFFECT VISIBILITY

The ideal way of specifying the design factors that affect visibility would be to give a series of curves showing how each of the physical variables affects human performance. It is possible to do this with machine controls, for example, where we can give human performance in terms of gear ratios and show clear optima. In the case of radar systems, it is impossible to give this kind of quantitative data for three reasons:

- (1) The number of variables is so great. It has been estimated that there are at least fourteen electronic variables that affect radar detection. To these must be added a number of other physical variables, those concerned with phosphor, for example. We still have not adequate data on the ways these variables act singly, much less in combination.
- (2) No one has yet figured out how to translate the electrical variables into visually significant ones, e.g., what is the equation to get from 'volts' to 'millilamberts'?
- (3) There is an enormous amount of variation from one radar to another, from one tube to another, and in one radar from time to time. A translation from 'volts bias' to 'millilamberts' might hold for a particular radar for a limited time, but it almost certainly would not apply as soon as the tube were replaced.

These considerations limit greatly what we can say about design factors in radar systems. It also accounts for the rather unusual recommendation given in item (3) below— that a signal generator be built into the radar system. It is believed that the human on-the-spot calibration of radar systems is the only feasible way of dealing with the complexities of the situation. The design factors that affect visibility are enumerated below.

- (1) **Signal size:** The signal size may be increased by increasing such electronic variables as beam width and pulse length. However, increases in pip size proportionately degrade scope resolution, and in this way limit the use of the display.
- (2) **Scope brightness:** Since the eye is most sensitive to brightness contrasts at higher brightnesses (above 1 ml.), an optimally constructed CRT should have characteristics such that maximum signal to background contrast is obtained when the background brightness is about 1 ml. or above.
- (3) **Scope brightness adjustment:** The optimum CRT bias setting for any piece of equipment depends upon video gain, antenna rotation rate, pulse repetition frequency, and random noise levels. It is recommended that a signal generator be provided with the equipment so that the operator can conduct visibility tests during operation. For any given set of operating conditions the operator can then adjust the CRT bias and other electronic variables so that the settings permit detection of the weakest signal that is simulated. This is particularly helpful in air search radar where the targets may not be available for such adjustments.
- (4) **Contrast direction:** The signals may be made to appear as bright spots on a dark background or as dark spots on a bright background. The visibility data immediately above apply to both contrast directions.
- (5) **Scope brightness distribution:** The scope brightness should be as uniform as possible over the entire scope face. In conventional radar the center of the scope usually gives a much brighter signal and background than the other portions of the scope. This impairs target detection and makes scope photography difficult.

### ADAPTATION LEVEL AND VISIBILITY

The dark adaptation curves on page 81 show that immediately after the eye has been exposed to high brightnesses (see brightness table on page 74), its sensitivity to dim visual stimuli is reduced. After a period of time in relative darkness this sensitivity is regained.

The graph below shows the time lost in the detection of a signal on a cathode ray tube screen as a function of the preadaptation brightness for various screen brightnesses. The signal, which subtended a visual angle of 1200 square minutes of arc at the eye, was about at the 99% probability of detection for an eye adapted to the brightness level of the task. In this experiment a detection time of five seconds is equivalent to immediate detection because it took five seconds for the subjects to move from the adaptation screen to the CRT screen.

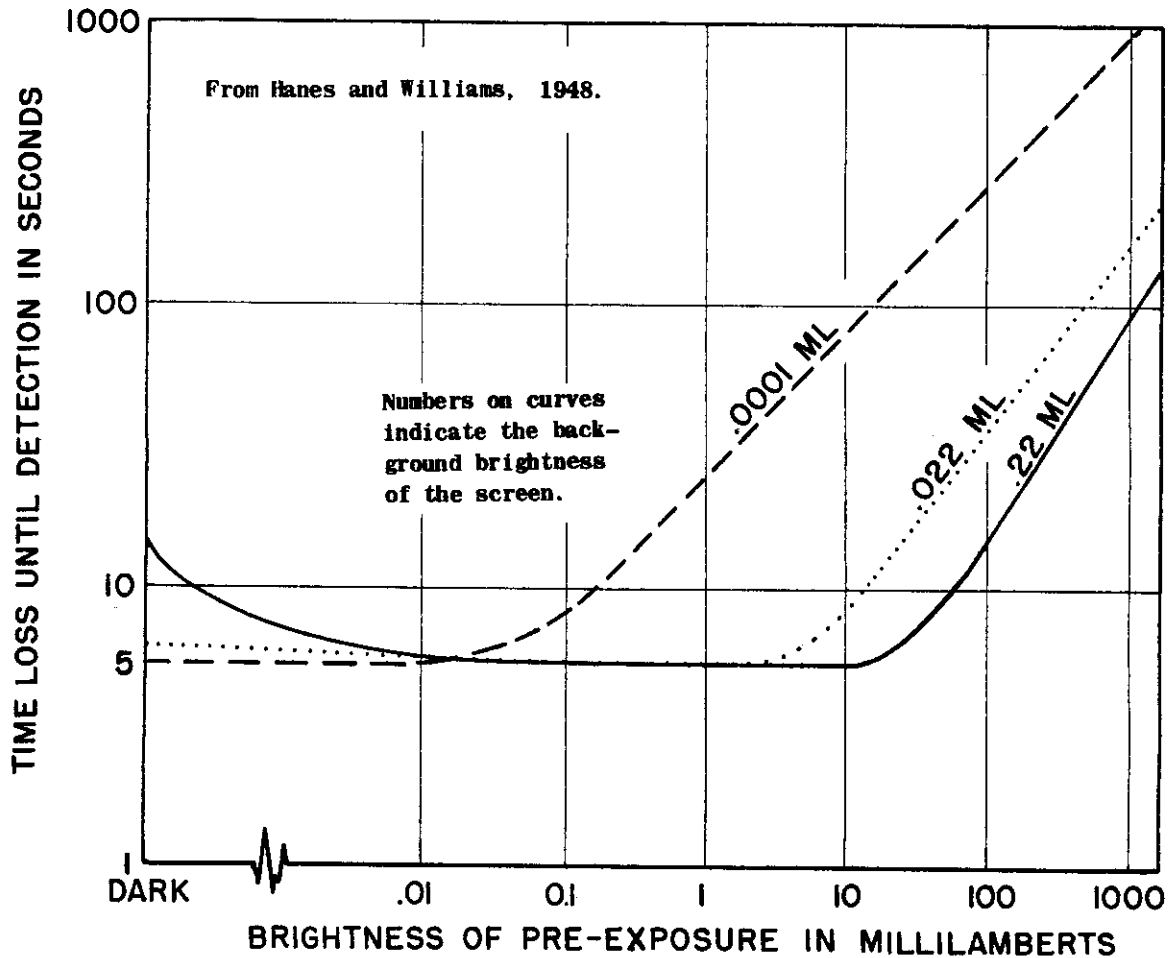

The graph reveals:

- (1) For very dim scopes (.0001 ml. background brightness) the operator may be pre-exposed to brightnesses of .01 ml. without impairing signal visibility.
- (2) For dim scopes (.022ml. background brightness) the operator may be pre-exposed to 2 ml. without impairing signal visibility.
- (3) For moderately bright scopes (.22ml. background brightness) the operator may be pre-exposed to brightnesses of 20ml. without impairing signal visibility.
- (4) A completely dark adapted observer will suffer a slight loss in detecting threshold targets on scopes with background brightnesses of about .02 ml. and above.

**GENERAL RECOMMENDATIONS**

- (1) Visibility of threshold radar signals is best when the operator is adapted to the level of the scope brightness.
- (2) If the operator must do other visual tasks at higher brightness levels, visibility will not be seriously affected if the higher brightnesses are not more than 100 times as bright as the average brightness of the radar screen. Therefore, if the operator must scan daylight skies (about 2,000 ml.) the average screen brightness should be set up to 20 ml. or more to maximize visibility under these conditions.

**SIGNAL STRENGTH**

We have seen how high pre-exposure brightnesses have affected the visibility of signals that were seen nearly 100% of the time for operators adapted to the level of the task. It was noted that with higher scope brightnesses the intensity of the pre-exposure could be greater without affecting the detectability of signals. However, it might be impossible to get maximum signal-to-background contrast ratio if the screen is required to be 1/100 as bright as the pre-exposure brightness. This is particularly true if the pre-exposure brightness is 100 ml. or more. It is then of interest to know what the signal strength must be in order to be immediately visible to an operator who has been pre-exposed to high brightnesses.

The graph below shows the time required until a signal is detected as a function of the pre-exposure brightness for signals of various intensities. In every case the background screen brightness is .022 ml. The signal subtends a visual angle of 1200 square minutes of arc. As before, the detection time of five seconds represents immediate detection. The lowest contrast (13%) is a signal at about the 99% probability of detection for operators adapted to the brightness level of the task. The other signals are, therefore, above this threshold level.

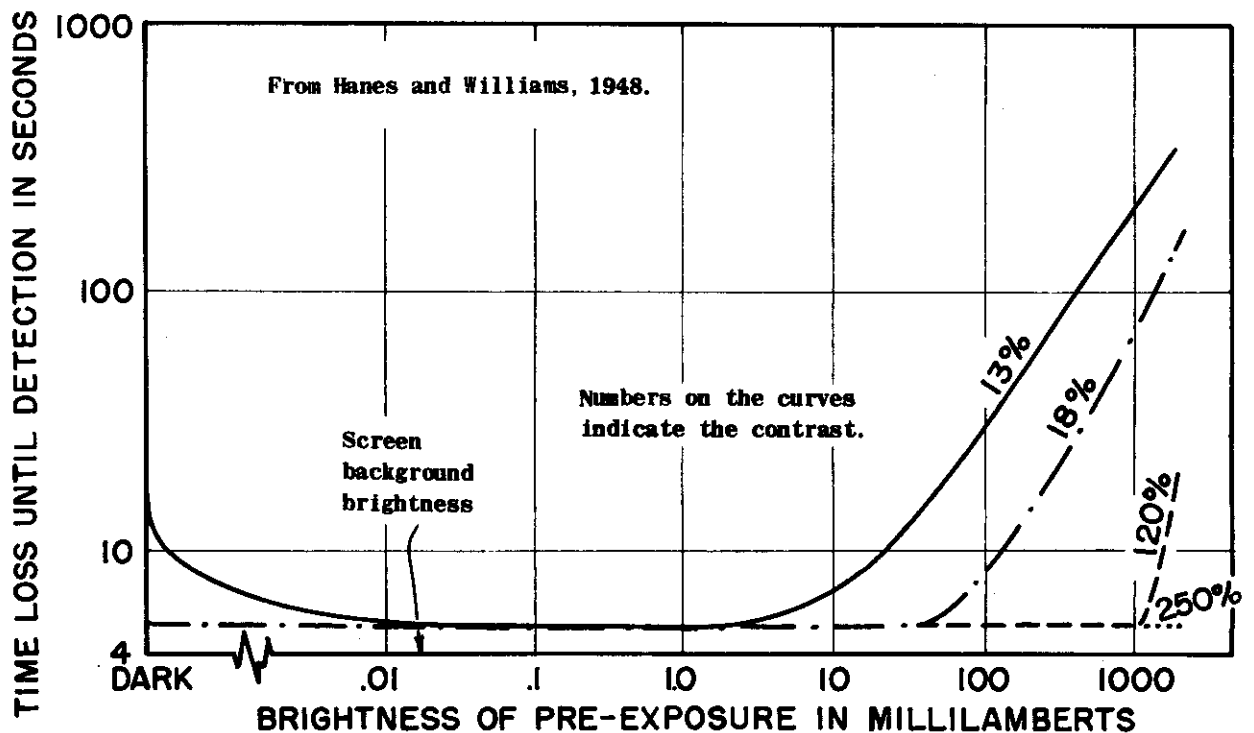

Time for detection of a signal as a function of pre-exposure brightness for various degrees of signal-to-background brightness contrast.

It is evident that with stronger signals (higher contrasts) the range of tolerable adapting brightnesses is much greater. Indeed, for this background brightness (.022 ml.) a signal which is 2½ times as bright as the background can be seen immediately after the operator has adapted to 2,000 ml. Therefore, if a given radar operation does not require the detection of weak signals, greater tolerances in the operator's brightness adaptation are permissible.

**DURATION OF PRE-EXPOSURE BRIGHTNESS**

We have seen that the eye is less sensitive to dim visual stimuli for some period after having been exposed to relatively high brightnesses. The data given above and on page 81 show the effect on visual sensitivity of adapting the eye to high brightnesses for five minutes or more. After the eye has been exposed to relatively high brightnesses for about 2½ minutes it reaches, for all practical purposes, a 'steady state' of adaptation. This means that longer periods of pre-exposure have little further effect upon the immediate subsequent sensitivity of the eye. However, if shorter periods of pre-exposure are used, the sensitivity is affected proportionately less. These relationships are shown below.

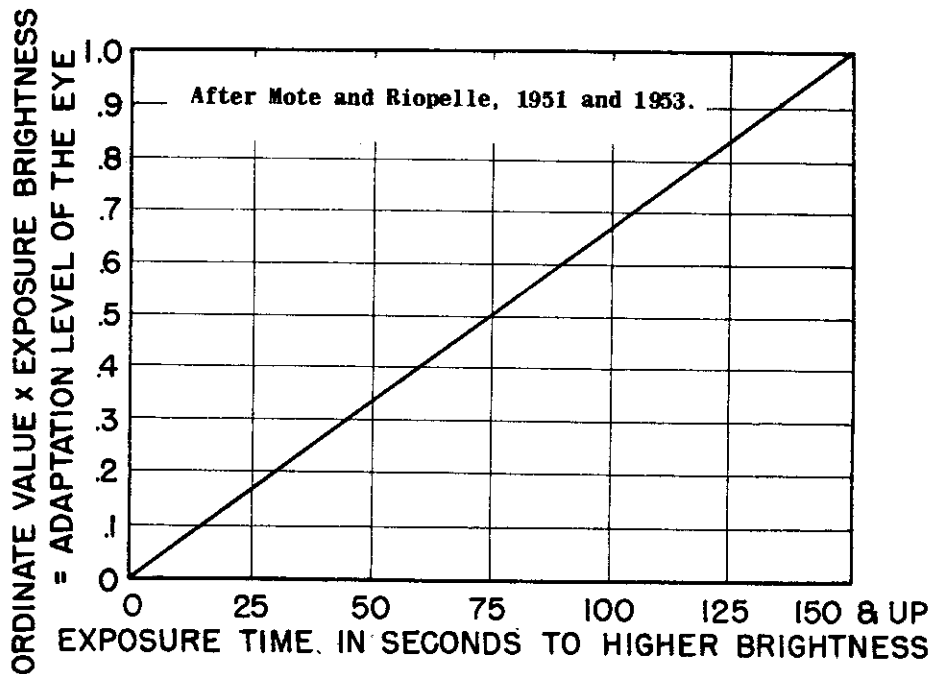

For any given exposure duration the value on the ordinate is used as a multiplier of the exposure brightness to give the steady state adaptation level of the eye.

This means that if the eye is exposed to 2,000 ml. (daylight brightness) for 15 seconds, the eye has a sensitivity loss equivalent to that of being exposed to 200 ml. ( $15/150 \times 2,000$  ml.) for 150 seconds or more. These adjusted values may then be used for the data above and on page 81. (See the table of approximate brightnesses on page 74.)



**VISIBILITY AND SIGNAL DURATION**

The visibility of dim signals is partially a function of the length of time for which they are exposed. The relationship between the duration of a flash of light and the relative intensity of the flash required to be seen is shown below.

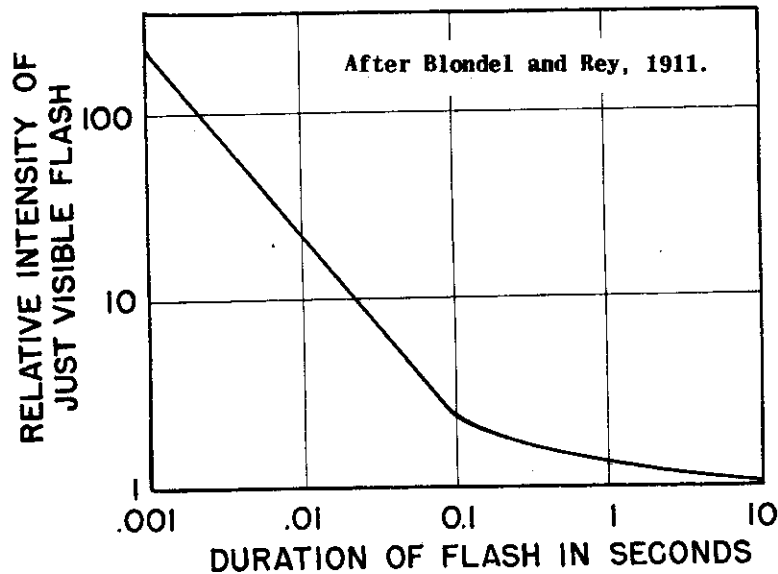

Relative intensity of just visible flashes of light as a function of the duration of the flashes.

It is seen from the above graph that the eye apparently summates energy fairly well up to about .2 seconds and that further exposure has little effect upon visibility. These data hold only for conditions where the observer knows the position of the signal. However, Bartlett and Sweet, 1949, found that the above relationships hold for target detection on cathode ray tubes; namely, it took about one second for an observer to have maximum ability to detect signals, but detection of signals was only slightly impaired for durations as short as .1 seconds.

**VISIBILITY AND VIEWING ANGLE**

Whenever possible the scope face should be in a plane which is perpendicular to the operator's normal line of sight. However, space for the equipment and personnel, and special lighting conditions may necessitate viewing the scope obliquely. Since oblique viewing of the scope would reduce the visual angle of the signal there would be a resultant loss in visibility for threshold targets. However, Williams, 1949, found that the scope could be tilted 30° from a position normal to the line of sight without noticeably affecting the detection of weak signals.

**VISIBILITY AND VIEWING DISTANCE**

Since it is generally agreed that 16 inches is a minimum viewing distance for prevention of visual fatigue, it is recommended that this viewing distance be used whenever practical. However, shorter viewing distances increase the visual angle subtended by signals and visibility can be improved by close viewing. Therefore, if periods of scope observation are short, and where it is important that dim signals be detected, the recommended 16-inch viewing distance can be reduced to ten or twelve inches. (See Bartlett and Williams, 1947; Craik and McPherson, 1945; McFarland, Holway, and Hurvich, 1942.)

### CATHODE RAY TUBE SCREEN SIZE

The solutions to the problem of 'optimal' scope size depend upon many complex factors. Some of the more important considerations deal with such things as what is being displayed, what the observer must 'see' in the display, the viewing distance, etc. Many of the factors involved in determining the solution to the problem of scope size are not fully understood. Nevertheless, some general statements can be made.

**Scope size and visibility:** If, when increasing scope size, the resolving power of the radar system is essentially unchanged (scope resolution is defined on page 29), signal detectability would be improved as a result of the increase in signal size. The extent of improved detection can be determined from the graph on page 30. Optical magnification of the CRT screen would result in about the same improvement. If signal size does not increase with scope size visibility will be unaffected.

**Scope size and resolution:** If the major electronic variables are held constant, increases in scope size do little to enhance the radar system resolution. However, the displayed detail will be larger and, therefore, more discernible to the eye. Scope magnification would have about the same effect.

If resolution is increased with scope size, scope interpretation of complex target areas might be considerably enhanced. Generally speaking, as scope resolution is increased the scope size will have to be increased (actually or optically) so that the increase in fine detail will be enlarged sufficiently to be seen by the operator. The ability of the eye to discriminate detail is discussed on pages 87-95.

**WORKPLACE LIGHTING AND CATHODE RAY TUBE DISPLAYS**

Many problems encountered in illuminating areas containing CRT displays are unique and are therefore considered here rather than in Chapter 6 on lighting. However, definitions of lighting terminology used here will be found in Chapter 6.

Conventionally, CRT displays are observed in rooms which are darkened to provide maximum visibility of the CRT signals. Room illumination can reduce the probability of detection of a weak signal in three ways:

- (1) Specular reflections (bright glare spots) from the glass surfaces of the scope face or from glossy surfaces in the area surrounding the scope face.
- (2) Excitation of the phosphor in the tube reduces the signal-to-background brightness contrast.
- (3) Loss of sensitivity of the eye by causing too high a level of adaptation.

Unfortunately, the darkened workspace, although desirable for scope visibility, is undesirable for other reasons. In aircraft it may be necessary for the scope observer, who may be the pilot, to look out at bright daylight skies. Moreover, the scope observer usually has other equipment, maps, instruments, and printed material which he must be able to see. In addition to this, other persons who must have adequate light for performance of their duties may be working in the same area. For these reasons it often becomes necessary to control the lighting in workplaces where radar scopes are used.

**GENERAL RECOMMENDATIONS**

Do not allow the ambient room illumination to contribute more than 25% of the screen brightness through diffuse reflection and phosphor excitation. (Williams and Hanes, 1949; Williams, 1947.) The visibility loss from ambient room illumination is a result of lowered contrast between the signal and the background.

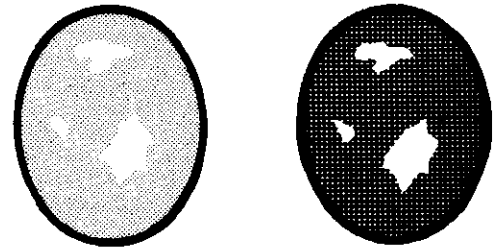

Room illumination may be sufficiently high for other visual tasks if the scopes are adequately hooded or shielded from the light. However, the use of these devices restricts the number of observers to a scope at any one time. When possible, assign tasks requiring high levels of illumination to other rooms. See also the next page on the topic of selective spectrum and polaroid lighting.

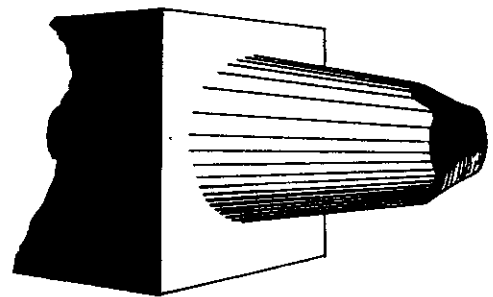

Surfaces immediately adjacent to the scope should be in a brightness range from equal to the brightness of the screen to 10% of this brightness. (see pp 76-78.) No light sources brighter than the radar signals should be in the immediate surrounds.

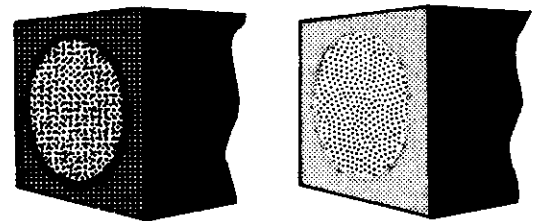

Surfaces immediately adjacent to the scope should have a dull matte finish. The reflectances of the surfaces should be such that the resultant brightnesses are consistent with the recommendations above.

Do not place light sources or glossy surfaces in a position which will permit specular reflections from the screen into the observer's eyes. The cone of reflectance is diagrammed at the right. See also the section on glare on page 76 and following.

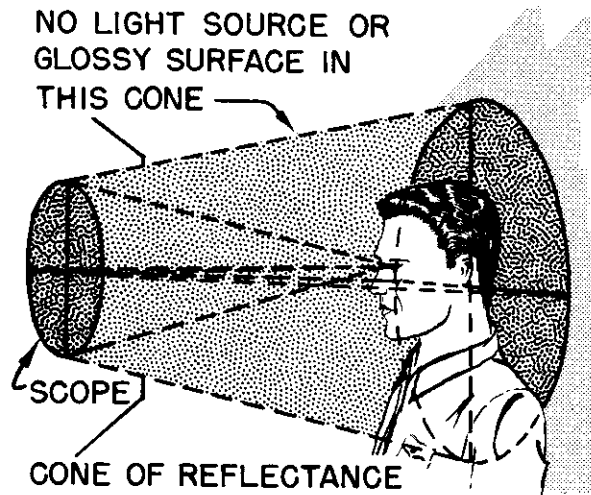

#### SELECTIVE SPECTRUM AND POLAROID LIGHTING

It is frequently desirable to have radar displays visible to several observers who are located at various positions in a room. A combat information center or an air traffic control center is an example of such radar usage. Because several people must view the radar display, the use of hoods or shields is undesirable. Yet a minimum level of illumination is necessary for visual tasks other than scope viewing. One method of permitting adequate room illumination without seriously impairing scope visibility is through the use of selective spectrum or polaroid lighting. These methods employ filters over the light sources and radar scopes. The arrangement of filters (or light sources independent of filters) is such that the light from the sources is absorbed by the filters over the displays. By this means the contrast of signal to background remains unaffected, and adequate room illumination may be maintained for other visual tasks in the room. The general principle is schematized below.

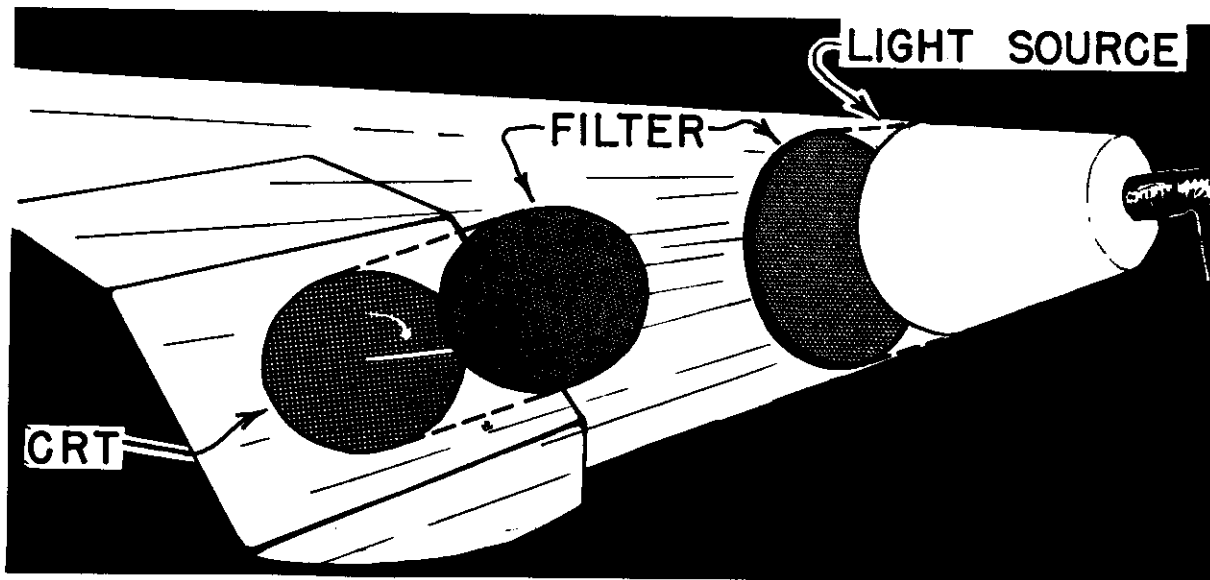

Various combinations of filters and light sources can be used. The following table summarizes various possible systems. Note that one column in the table shows the percent radar screen brightness loss as a result of the absorption of the filter. The graph on page 30 shows that for lower background brightnesses the contrast must be increased to maintain the same probability of detection. A filter over a radar screen does, therefore, affect the probability of detection for weak signals.

SUMMARY TABLE OF LIGHTING SYSTEMS

Ambient Light Sources And Filters	CRT Scope Filters	Scope Phosphor	Approximate Brightness Loss *	Advantages	Disadvantages
Sodium yellow source with no filter. Energy emission 5900 A.	Didymium filter- Absorbs 5900 A.	P-7	60%	No filter required over source.	Color coding limited. Yellow light disturbing.
		P-19	63%		
Mercury light with no filter. Emission below 5900 A.	Red filter which absorbs energy below 6,000 A.	P-7	90%	No filter required over source.	Screen brightness loss great. Color coding limited.
		P-19	77%		
Fluorescent with blue filter. Emission below 5400 A.	Orange filter which absorbs energy below 5400 A.	P-7	38%	Screen brightness loss small.	Color coding limited. Blue light is unpleasant.
		P-19	15%		
Any light source with a polaroid filter.	Polaroid filter oriented perpendicularly to source filter.	P-7	65%	Natural lighting. Color coding unaffected.	Reflected light is depolarized. Much light control necessary.
		P-19	65%		

\* The screen brightness loss values are for conditions where the operators do not wear goggles with filters of the same type used over the CRT display. If such goggles are worn the screen brightness loss is greater than the values given. The percent brightness loss for other phosphor and filter combinations can be easily determined by superimposing the filter transmission curve and the phosphor emission curve (both plotted in percent relative energy as a function of wavelength) and calculating from these curves the total loss in brightness. (The phosphor emission curve should be in terms of percent relative photometric energy.)

For more detailed information concerning the above lighting systems see Kraft and Fitts, 1954, and Lund, 1952.

## METHODS FOR INDICATING RANGE ON RADAR DISPLAYS

The various methods for indicating range can be evaluated in terms of (1) the accuracy of the estimates, and (2) the speed in making range estimates. In the evaluation of the range indicating methods we will consider the optimal design within a method and also make comparisons among the various methods.

### RANGE MARKERS

The diagrams to the right illustrate the arrangement of range markers on polar coordinate and rectangular coordinate displays. The recommendations that follow apply primarily to the range markers on the polar coordinate display. However, they probably apply fairly well to the rectangular coordinate display.

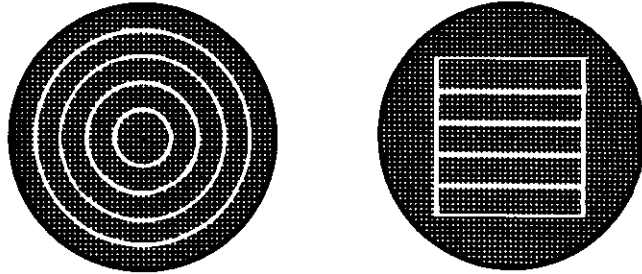

**Range mark interval:** The range mark interval scale should be represented as part of a scale which starts at zero, with the numbered marks progressing by ones, twos, or fives, and with the appropriate number of zeros after each digit. Examples of good numbering systems are shown below:

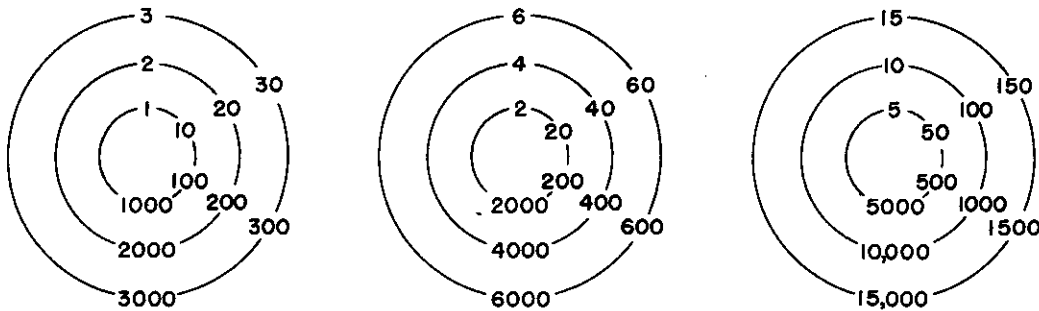

No other range mark numbering system is acceptable. In general, progression by ones (1, 2, 3, or 10, 20, 30, etc.) is superior to the other two acceptable numbering systems. (Chapanis and Leyzorek, 1950; Barber and Garner, 1951.)

### RANGE RING SEPARATION DISTANCE

Two tasks are involved in the estimation of range values. These are (1) identification of the nearest inner range mark value, and (2) interpolation of the signal position between the range marks. For a given scope size, the number of range marks used affects the range mark spacing. If the scope size is also fixed, a change in the number of range marks affects the numbering system of the range marks. The affect of range mark spacing on speed and accuracy is as follows:

**Interpolation accuracy:** An operator is able to interpolate the position of a signal between two range marks with the following accuracy:

- (1) Approximately 50% of the range estimates will be in error by less than 4.1% of the distance between the range marks.
- (2) Approximately 95% of the range estimates will be in error by less than 14.1% of the distance between range marks.
- (3) Operators tend to overestimate the target range by 2% of the interval distance, i.e., there is a positive constant error of 2% of the interval.

These values apply to situations where:

- (1) The distance between the range marks subtends a visual angle greater than 22 minutes of arc.
- (2) The signal is a relatively small, well defined spot.
- (3) The operator proceeds as rapidly and accurately (attempts to read to the nearest one percent of the interval) as possible.

**Range mark identification:** Errors occur in the identification of the range marks adjacent to the signal. Such errors are gross errors and are multiples of the range mark interval value. For example, if the range marks represented intervals of 1000 yards, the gross errors would be of this value or multiples of this value. The frequency with which gross errors occur depends upon the number of range marks used on a display. The graph below shows the percent of the readings in error as a function of the number of range rings used. These data apply to operators who are reading ranges as rapidly and accurately as possible. The range rings were optimally scaled, i.e., every fifth ring was discriminably different (thicker) from the others. The time required to determine the range of each signal is also included on the graph. (Baker and Vanderplas, 1954.)

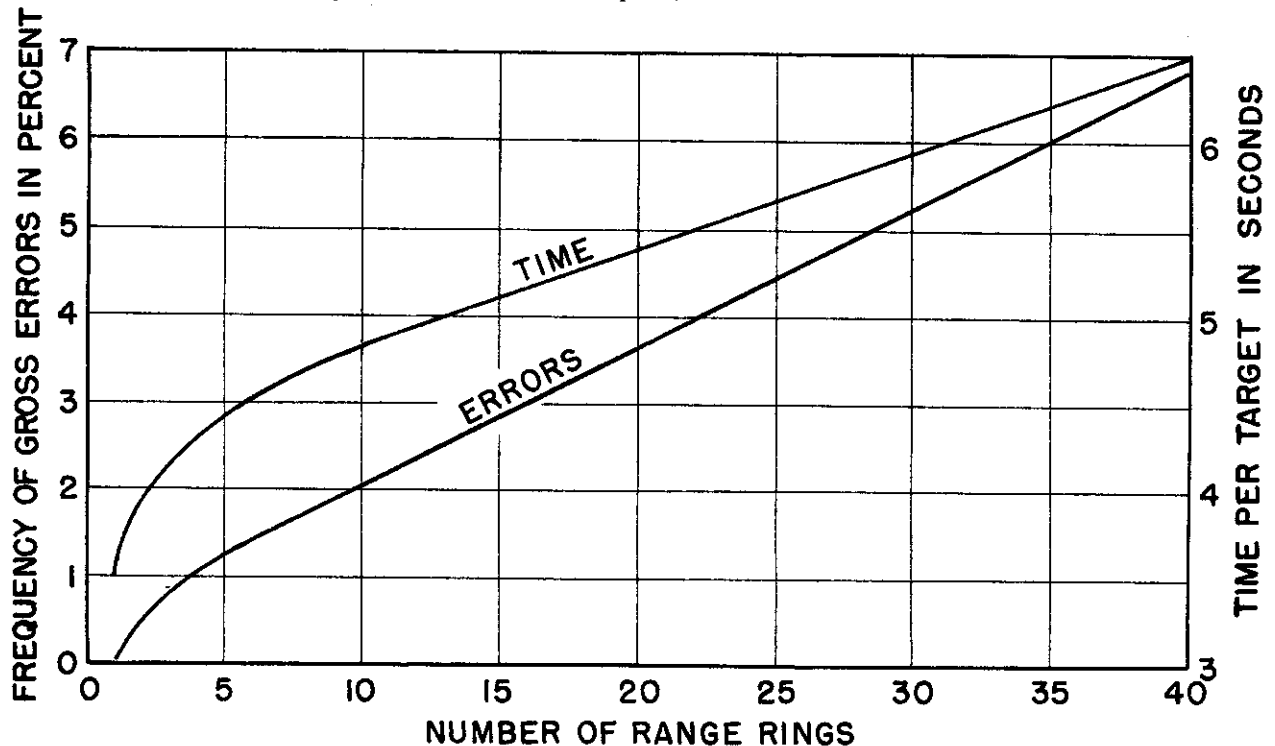

**Coding range marks:** If more than five range marks appear on a radar display, every fifth mark should be brighter than the others. This assists the operator in the identification of any particular mark. (However, see also Garner, Saltzman, and Saltzman, 1949.)

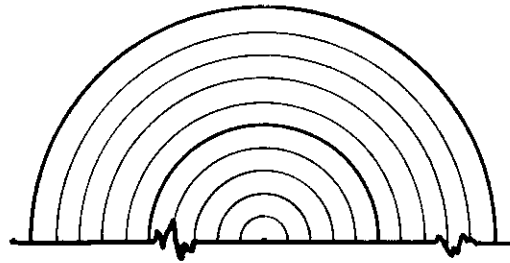

**ELECTRONIC RANGE CURSOR**

This method of range indication is by means a movable range marker. The marker or cursor moves with the antenna sweep and leaves a decaying trace as illustrated in the diagram to the right. The operator moves the position of the cursor radially by means of a crank or knob. When the signal is bisected the range value is read from the counter. The operator should be able to control the cursor brightness so that the cursor trace does not completely decay in the time required to make one revolution.

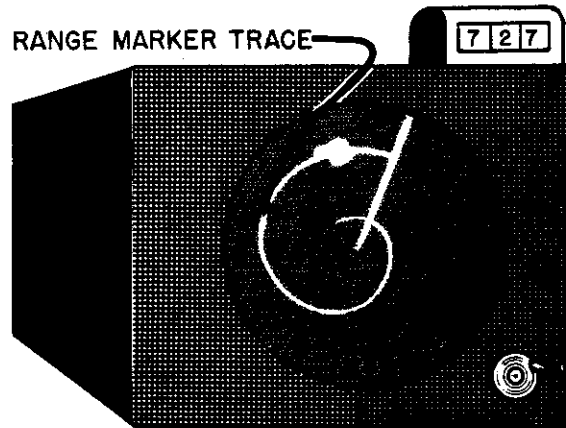

**PANTOGRAPHIC METHOD OF INDICATING RANGE**

The position of a radar signal may be determined by the use of a pantographic tracking device. The operator positions the point or cross hair cursor over the signal on the scope and reads the coordinate information from counters geared with the pantographic arm movement. The diagram at the right illustrates the pantographic device. (Ford et.al., 1949 and 1950.)

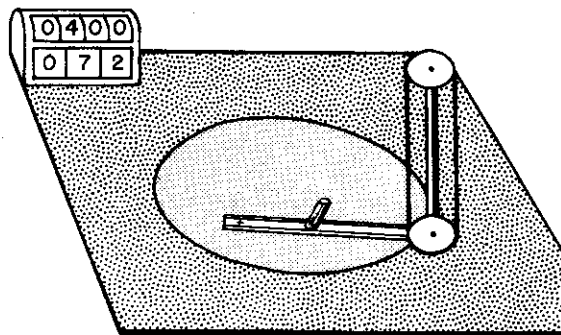

**EVALUATION OF RANGE AID METHODS**

**Speed:** The graph below shows the amount of time required for an operator to determine the range and bearing of one target for various range aid methods. The operators were instructed to proceed as accurately and rapidly as possible. The bearing in each case was estimated (no cursor). Reports were oral.

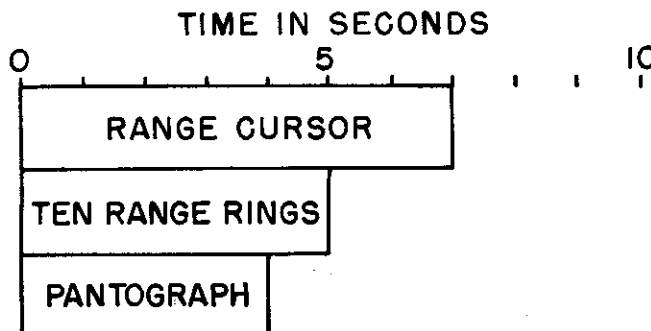



**Accuracy:** It was noted above that 50% of the range estimates were in error by 4.1% of the range mark interval distance. Therefore, interpolation error, expressed as the percent of the total range in error, is inversely proportional to the number of range marks used. However, it was also noted that as the number of range marks is increased the number of gross errors increases and more time is required to make the reading.

The accuracy of determining range by use of a range cursor or pantograph is dependent upon the operator's ability to bisect a signal or to center a point on a signal. For a signal .261 inches in diameter, 50% of the readings will err by less than .002 inches (less than 1% of the diameter) and 95% will err by less than .006 inches. (Ford et al., 1949.) These accuracies are possible with the pantograph if only two seconds of time are allowed. The range cursor method requires about 15 seconds to acquire this level of accuracy. When the operator proceeds more rapidly (one target every seven seconds) the range cursor errors become ten times greater. (Chapanis, 1949; Gebhard, 1948; Gebhard and Bilodeau, 1947.)

### GENERAL CONCLUSIONS

When accuracy alone is essential (speed not important) the range rings are inferior to the other methods. However, when speed and accuracy are both stressed; the range marks are superior in both speed and accuracy to the range cursor method. The pantographic method is superior to the other two methods in both speed and accuracy.

### METHODS OF INDICATING BEARING ON RADAR DISPLAYS

The various methods for indicating bearing may be evaluated in terms of the speed and accuracy with which the operator is able to read or relay the information. Bearing may be indicated by the following methods:

**Bearing dial and cursor:** A mechanical or electronic cursor is moved by a crank or knob until the signal is bisected. The bearing value is read from a bearing dial that is around the scope.

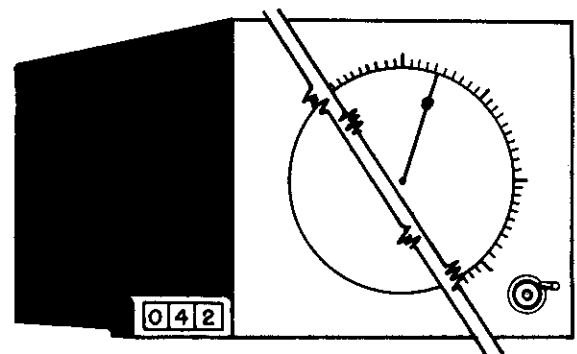

**Bearing counter and cursor:** This method is the same as the one above except the bearing is read from a counter.

**Bearing dial estimate:** The operator sights along the target to the bearing dial and in this way estimates the value. No cursor is used.

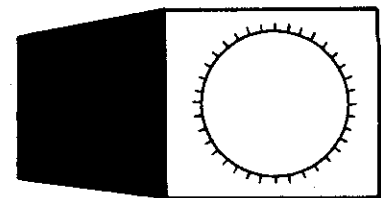

**Pantograph:** The operator manually places a cross hair over the target and the bearing is then read from a counter.

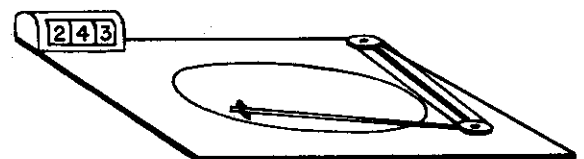

**Overlay - radial lines:** A transparent overlay is placed over the scope face. It may be designed as shown in the diagram. The radial lines assist in estimating the bearings.

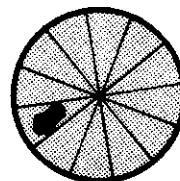

#### EVALUATION OF BEARING AIDS

**Accuracy:** The graph below shows the approximate accuracy scores for the various methods. These data apply when the operator is performing rapidly. (Data from Reed and Bartlett, 1947; Gebhard and Bilodeau, 1947; Chapanis, 1949; Bartlett, 1947; Gebhard, 1948; Ford, et al., 1950.)

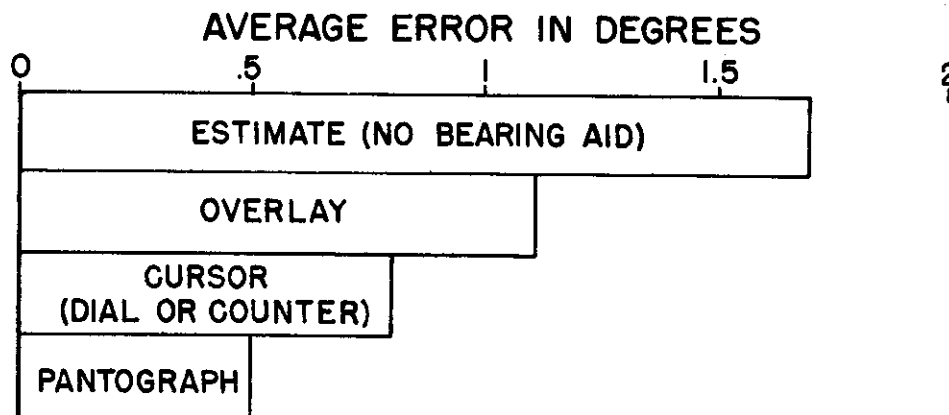

**Speed:** There is a saving in time of about one second in estimating bearing (no aids) and with the use of overlays over the bearing cursor methods. However, the pantograph is superior in both speed and accuracy to the other methods considered.

#### TIME DELAY IN DATA TRANSMISSION

Since radar signal information deals almost exclusively with moving targets (i.e., ground radar observing moving aircraft, moving aircraft observing ground targets, and moving aircraft observing moving aircraft) the delay from the time the signal appears on the scope until the position of the target is clearly defined and transmitted is sometimes extremely critical. For example, if a target is closing at 500 knots and the time delay is five seconds, the 'present' range report will be in error by about 1600 yards purely as a function of delay in the data transmission. Because of large errors introduced into a system by time delays it is recommended that the most rapid data transfer system be used. (See Garner, et al., 1947.)

#### SYSTEM CONSIDERATION IN RADAR DESIGN

When the designer comes to think about range and bearing readings from radar scopes, perhaps the most important thing for him to think about is the system design problem - should a man be reading bearing and range at all? Since this method is time consuming and inaccurate why have a man read these data? In many systems, radar operators read bearing and ranges for the purpose of relaying the numbers to another man who plots them on a wall type plot. If this is the only function man serves, it is much better to design an automatic transfer link for data transmission. If, however, some typically human function will be applied to the data, the above methods of reading bearing and range may have to be used.

### THREE COORDINATE INFORMATION DISPLAYS

To determine the position of an aircraft in space it is necessary to display three coordinates to the operator. These are usually bearing, range, and altitude. A conventional method for displaying three coordinates on two scopes is shown below.

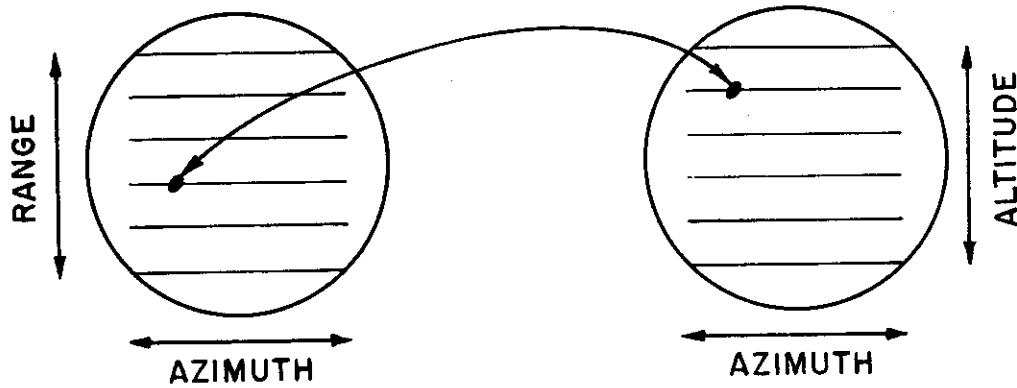

Attempts have been made to display three coordinates of information (e.g., range, bearing, and altitude) in a single integrated display. It is believed that if this is properly done there will be greater ease of interpretation and a savings on equipment space. One proposed method of displaying three coordinates on a single display is shown at the right. Two signals appear on one bearing for a single target. The range is displayed in the inner annulus and the altitude is displayed in the outer annulus. When the bearing is estimated and range rings are used the bearing, range, and altitude can be orally reported in 8.8 seconds per target. (Gebhard and Bilodeau, 1947.) This method requires 1/3 less time than the two scope presentation.

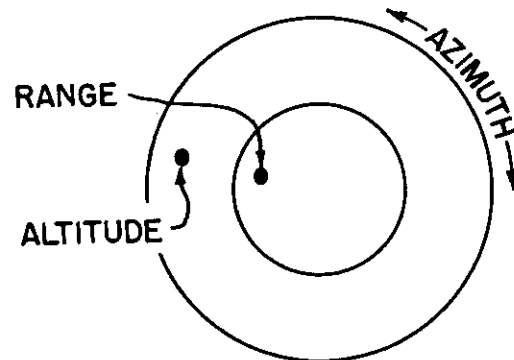

It should be noted that although this display allows for rapid reading of the space coordinates in quantitative terms (yards and degrees) it does not result in an accurate 'perception', i.e., the spatial positions are not easily visualized.

#### CODING OF THE THIRD COORDINATE

The value of a third (or fourth etc.) coordinate can be displayed by some method of signal coding. For example, range and bearing can be displayed as on the conventional PPI display, and the third coordinate, altitude, could be coded by some characteristic of the signal. Various methods of coding are discussed on pages 46-55.

## VISUAL CODING -- THE DISPLAY OF ADDITIONAL TARGET DATA

The conventional scaling methods used on radar scopes or wall plotting boards usually present two dimensions of information. These two dimensions are usually range and bearing (PPI display), but they may be altitude and bearing (C-scan.) If three dimensions, e.g., range, bearing, and altitude, must be displayed, and be quickly and easily interpreted, display problems arise. Several methods of displaying three dimensions of information have been discussed on page 45. These conventional display methods code information by angular orientation of the signal ( bearing ) and interpolated distance between lines (range and altitude.) However, more target information is usually required. This section is concerned with additional means of coding target information in such a manner that the display is quickly and easily interpreted. If appropriate coding methods are used, more information can be presented on a single display.

### WHAT MAY BE CODED

In addition to the conventional display of range and bearing the following information, for example, might be given on the same display by several coding methods:

- (1) Friend or foe.
- (2) Type of target (missile, bomber, fighter, interceptor, etc.)
- (3) Speed and course of target.
- (4) Altitude of target.

The coding recommendations that follow are evaluated with consideration of the human operator's capabilities and not of the capabilities of the now available electronic equipment.

### VARIOUS CODING METHODS

Additional target information can be coded by varying the following conditions:

- |           |                         |                  |
|-----------|-------------------------|------------------|
| (1) color | (4) visual number       | (7) brightness   |
| (2) shape | (5) line length         | (8) flash rate   |
| (3) size  | (6) angular orientation | (9) stereo-depth |

The relative merits of the above coding methods depend upon:

- (1) The number of absolutely identifiable steps (such as the number of colors or sizes that can be identified without confusion) contained in a given code method.
- (2) The immediate interpretability of the code. This refers to the ease with which the operator is able to differentiate between friends and foes, or between bomber and cargo craft, etc.
- (3) Its affect upon operator fatigue and distractability, or its interference with other codes.
- (4) The space required to use the various codes.

**SUBJECTIVE SCALING**

When constructing a code scale which requires the observer to identify targets on the basis of the magnitude of some signal characteristic (such as signal area, brightness, length, etc.) certain recommended practices should be observed. Since a code is more efficient when each scale value is equally difficult (or easy) to identify, the scale values should be selected so that they are equally identifiable. A rough rule of thumb procedure to obtain such a scale is as follows: the individual scale values should be selected so that they progress in magnitude by a constant ratio, i.e., the values should be equally spaced on a logarithmic scale. For example, if five areas are to be used to code information in which the smallest area is .01 square inches and the largest area 1.0 square inch, the intermediate values should increase in magnitude by a constant ratio, i.e., .01, .032, .10, .32, and 1.0 square inches. If a linear scale is used the values will be .01, .257, .505, .752, and 1.0 square inches. The two scales are shown below. It is evident by mere observation that the linear scale values of 1 or 2 would be more easily identified than if they were 4 or 5.

**LOGARITHMIC AREA PROGRESSION**

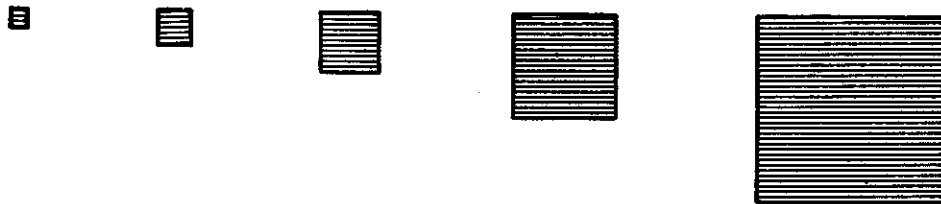

**LINEAR AREA PROGRESSION**

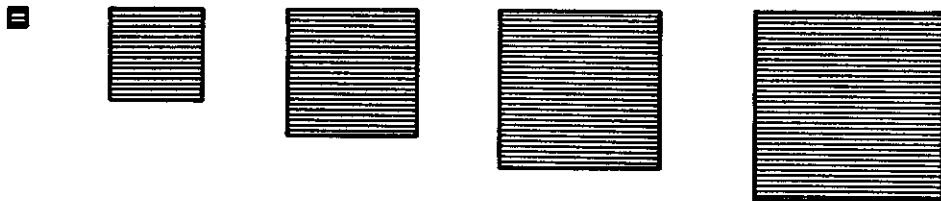

**CODE COMPATIBILITY**

Information may be considered to be quantitative, qualitative, or both. Qualitative information concerns kinds of objects or relationships such as friend or foe, bomber or fighter, etc. Quantitative information concerns the extent or magnitude of an object or relationship such as the speed of a missile, the altitude of a bomber, etc. Methods of coding information can also be considered as quantitative, qualitative, or both. Codes relying on geometric shapes or colors are considered to be qualitative codes because the various colors and various shapes are qualitatively different. Codes relying on size, brightness, length, etc. are quantitative codes because these differences are solely quantitative. Number codes can be considered to be qualitative or quantitative. Codes are more easily interpreted when qualitative codes are used to code qualitative information and when quantitative codes are used to code quantitative information. This is what is meant by code compatibility.

### CODING METHODS

**Color coding:** The number of spectral hues that a normal observer can easily identify depends upon:

- (1) The brightness of the light source.
- (2) The size, in visual angle, of the light source.
- (3) The particular colors used.

The ten spectral hues shown below can be identified correctly nearly 100% of the time by relatively inexperienced observers if the:

- (1) Source has a brightness of one mL. or more.
- (2) Source subtends a visual angle of 45 minutes or more.

However, the brightness or size could probably be reduced by a factor of ten without seriously affecting the identification accuracy. If white is included the number of identifiable hues is increased to eleven.

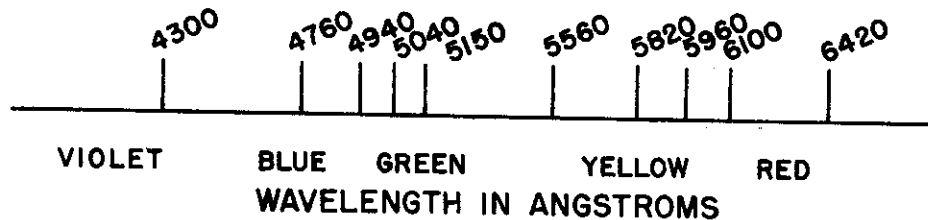

Approximately the same number of identifiable colors were found when using filters (varying in saturation as well as color). See Halsey and Chapanis, 1951 and 1953. See also Hill's data on page 97 and color coding for the color-blind on page 96.

**Shape coding, numerals and letters:** The number of shapes that an observer can correctly identify is extremely large. Letters and numerals and combinations of these are unlimited. The limiting factors in using letter and numeral coding are:

- (1) The space restrictions
- (2) The operator's ability to associate the symbols with the appropriate functions.

With good definition and high brightness contrast, numerals and letters are easily identified when they subtend visual angles as small as five minutes (1/40 of an inch-high symbols read at a 15-inch viewing distance). Because of relatively poor resolution on present-day radar, larger symbols would have to be used, and thus the space requirements will limit the usability.

Some data have been collected concerning the search time required to locate a signal coded by a numeral as a function of the number of other similarly coded signals on the same display. (Green, McGill, and Jenkins, 1953) The graph below shows the search time required to locate a specific numeral as a function of the number, or density, of the numerals on the display. Two numeral orientations were used. In one case the numerals were upright with respect to the observer; in the other case the numerals were randomly oriented. The displays are illustrated below.

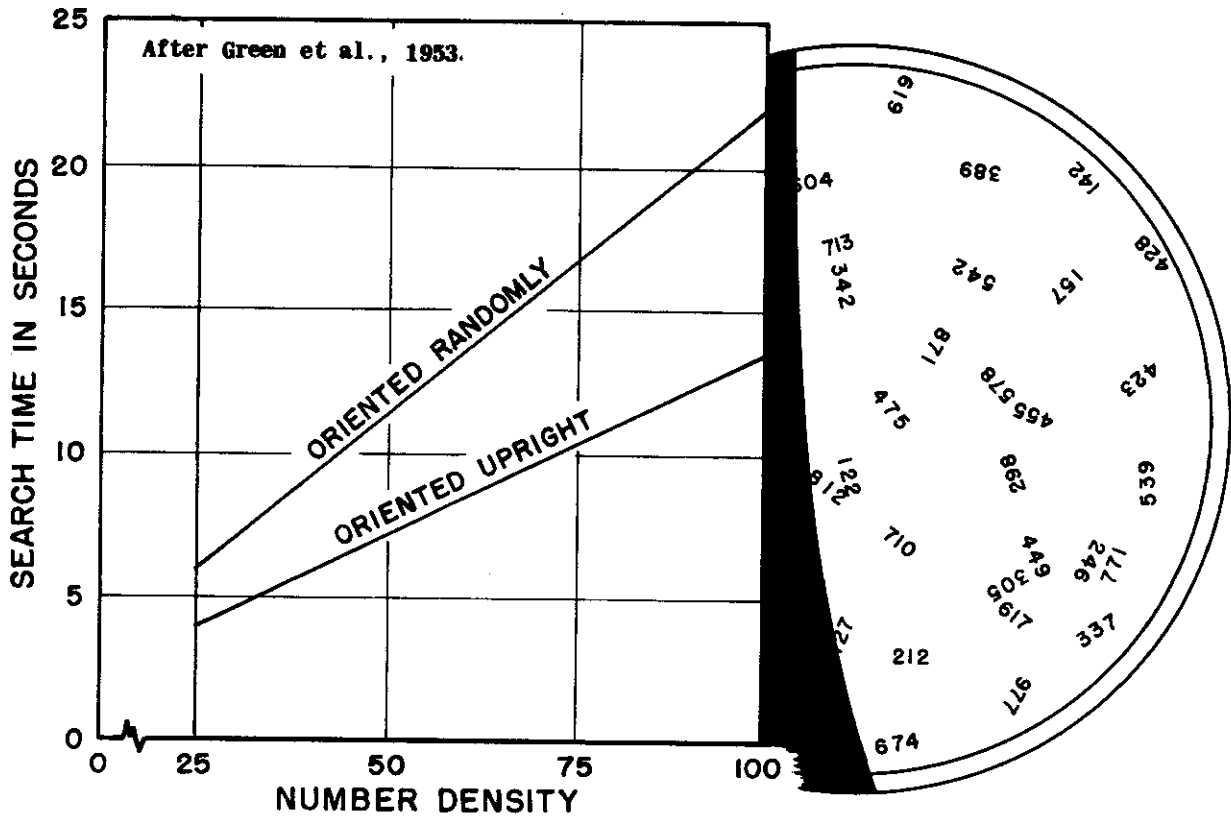

Conditions: (1) The visual angle subtended by the display was 20°. This is equivalent to the visual angle subtended by a radar scope seven inches in diameter at a viewing distance of 20 inches.

(2) The visual angle subtended by the numerals was 14 minutes. This is equivalent to the visual angle subtended by a 1/12-inch letter at 20 inches viewing distance.

Results:

(1) Search time is shorter when the numeral density is less.

(2) Search time is shorter when all of the numerals are upright with respect to the observer than when they are randomly oriented.

(3) When the numerals are clearly defined, the addition of moderate background clutter has little effect on search time.

(4) When the color of the numeral to be searched for is known, the presence of other colored numerals does not significantly affect search time. For example, if the numeral density is 50, of which 25 are red and 25 are green, the time taken to locate a given red number is equivalent to the situation where the number density is 25.

**Shape coding, geometric shapes:** The geometric shapes drawn below are easily identified. They are given in rank order on the basis of the time required to identify each from a complex field of shapes (Sleight, 1952).

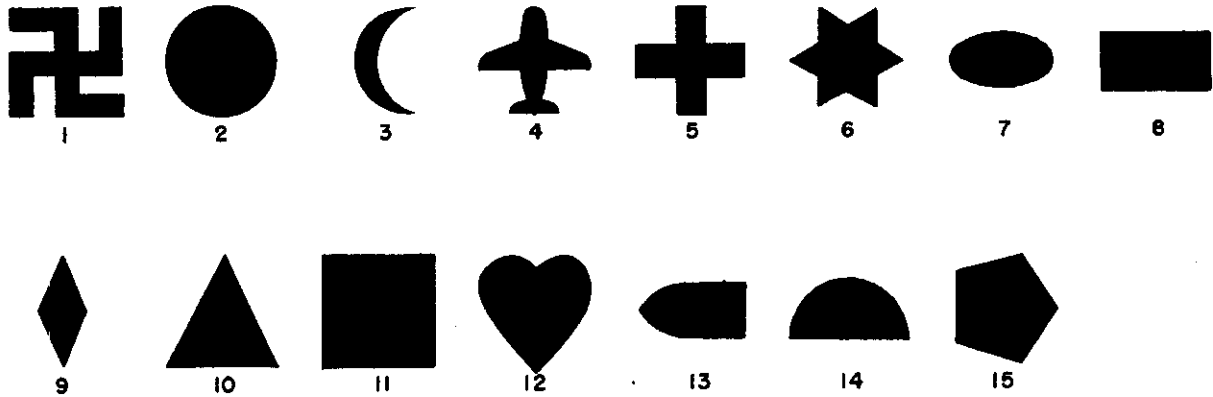

These forms can be identified correctly nearly 100% of the time if the:

- (1) Maximum dimension subtends a visual angle of 10 minutes or more.
- (2) Contrast and definition are near optimal values.

**Area coding:** Information can be coded by correlating signal area with some actual characteristic of the target. The graph below reveals the percentage of readings in error as a function of the number of areas the observers had to identify.

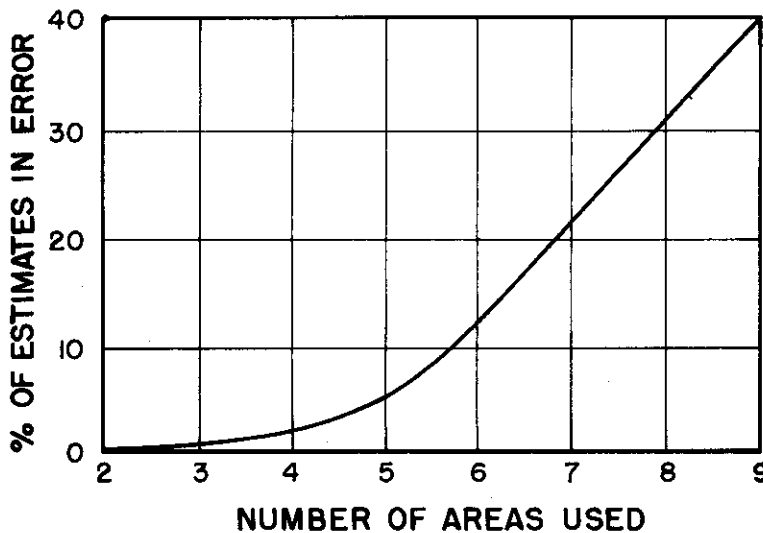

After Reese et al., 1953.

The signals were isosceles triangles with a base-altitude ratio of 5/3. The smallest triangle subtended a visual angle of 10' (base) by 16' (altitude), and the largest triangle 48' by 1°20'. The areas of the intermediate size triangles were equally spaced on a logarithmic scale. (At 18 inches viewing distance these triangles range in altitude from .09 inches to .42 inches.) It is evident that if more than five size-steps are used within this range of sizes, the errors of identification of any particular size become intolerable.



**Visual number coding:** A target can be coded by correlating some dimension of information with the number of dots comprising the target signal. For example, a one dot signal would represent a target value that is different from a two or three dot signal. The graph below shows the percent errors made in estimating the number of dots as a function of the number of dots displayed. The signals were exposed for less than 1/10 of a second so that the observers were unable to count but had to estimate the number of dots exposed.

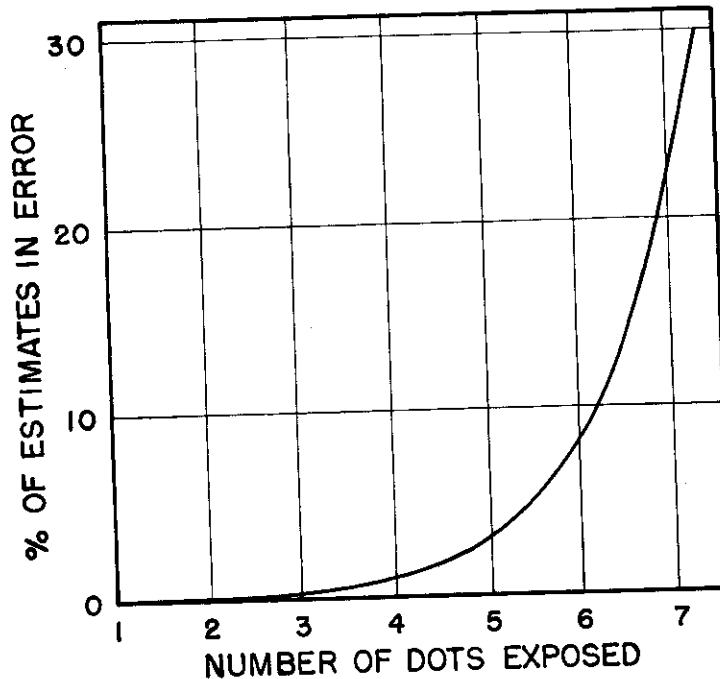

After Oberly, 1924.

The graph reveals:

- (1) Errors are negligible for identification of signals coded by five dots or less.
- (2) Above six dots, errors rise rapidly.

The above graph is for "immediate identifiability" of the number of dots. If more time were allowed for observation, the accuracy would be greater. However, the time required for identification is usually critical. If immediate identification is required, it appears that five or six coding steps could be used to code signals. It should be pointed out that the above number (6) of usable coding steps applies to a display on which the dots are randomly located. Uniform spacing, symmetrical configurations, or recognizable patterns, if used, would increase the number of usable coding steps. The use of patterns of dots, however, is actually a problem of shape coding.

**Line length coding:** In using line length to code information one needs to know the accuracy of identifying any simple line length as a function of the number of line length values used. The number of line lengths, each of which can be correctly identified, depends, in part, upon the range of line lengths used. Assuming that a range of lengths from 0.1 inch to 1 inch (at 18 inches viewing distance) is practical for use on displays, the problem is to determine how many additional intermediate lengths can be used without resulting in confusion. The graph on the next page shows the percentage of identification errors as a function of the number of line lengths used. In each case the shortest line is 0.1 inch and the longest is 1.0 inch. The intermediate lengths are equally spaced on a logarithmic scale, i.e., they progress by equal ratios.

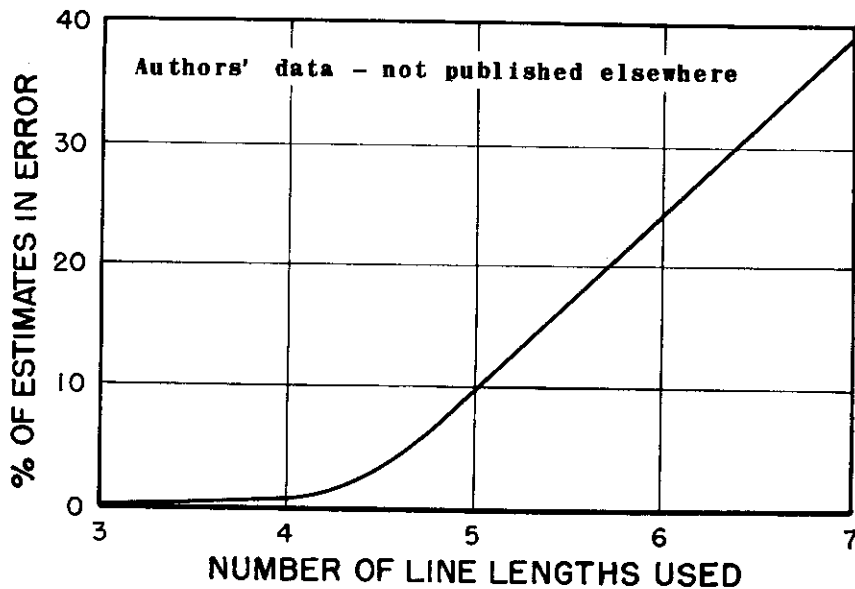

The graph reveals:

- (1) Up to four line lengths (ranging from 0.1 to 1.0 inch) can be identified without error when presented singly.
- (2) When five line lengths are used, errors of identification occur about 10% of the time.
- (3) When more than five line lengths are used, errors of identification increase rapidly.

A possible application of line lengths in coding information is discussed immediately below.

**Coding by angular orientation:** The value of using angular orientation of lines to code such information as target course depends upon:

- (1) Target course accuracy requirements.
- (2) Space available on the display.

The display below illustrates how such a coding method could be used. The angular orientation (bearing) of a line indicates the direction of movement, and the length of the line is directly proportional to the velocity of the target. Line length coding is discussed above.

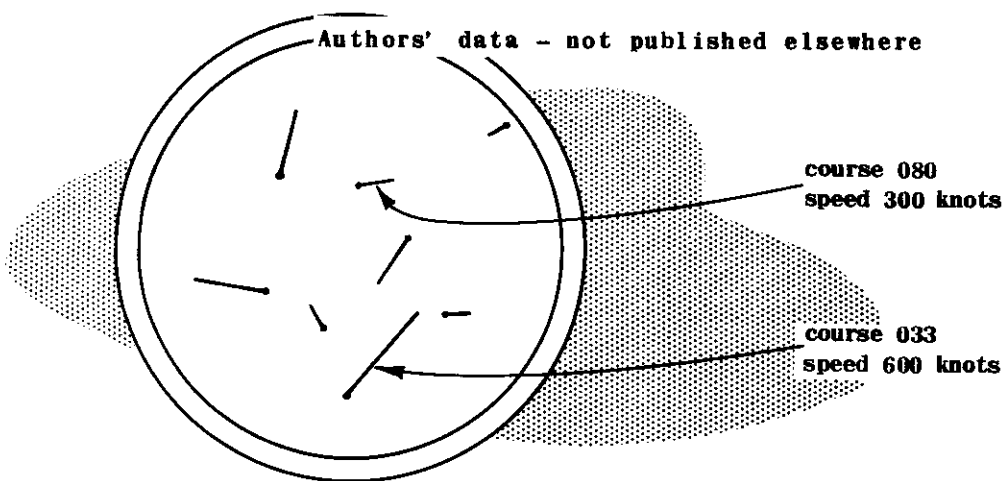

The accuracy of estimating target course by this coding method is as follows:

- (1) 50% of the course estimates will be in error by less than 6°.
- (2) 95% of the course estimates will be in error by less than 15°.
- (3) These values are approximately correct for line lengths as short as 0.1 inch (visual angle of 12 minutes of arc at 28 inches viewing distance) and for untrained observers.
- (4) The errors are 55% greater for courses from 180° to 360° than for courses from 0° to 180°. This error might be reduced if the 180° to 360° courses were expressed in minus values of 0° to 180°.

**Brightness coding:** The number of brightness steps that an observer can correctly identify depends, in part, upon the range of brightnesses available. Assuming that a range from 1 to 50 mL is practical, an observer, at best, can probably use not more than 3 or 4 brightness steps.

Brightness coding is generally unsatisfactory because it results in poor contrast effects. The less bright signals tend to be obscured by brighter surrounding signals. Also, such uneven brightnesses are frequently distracting and fatiguing.

**Flash rate:** Little applicable data exist on this particular coding method. However it appears as though no more than five identifiable flash rates could be used even under the best conditions. In general, flicker coding is unsatisfactory because fairly high brightnesses are required if higher flicker rates are to be seen as flicker. The task of selecting signals of particular flickering rates from a field of flickering signals is difficult and annoying.

**Stereo-depth coding:** The use of stereoscopic depth has been considered as a method of coding information. Stereoscopic depth results from binocular disparity, i.e., a slightly different picture is given to each eye. When the degree of disparity is not very great the images are fused, that is, the two images are seen as one. It is the fusion of these disparate images that produces stereoscopic depth perception. The diagram below illustrates the nature of a display that results in stereo-depth perception.

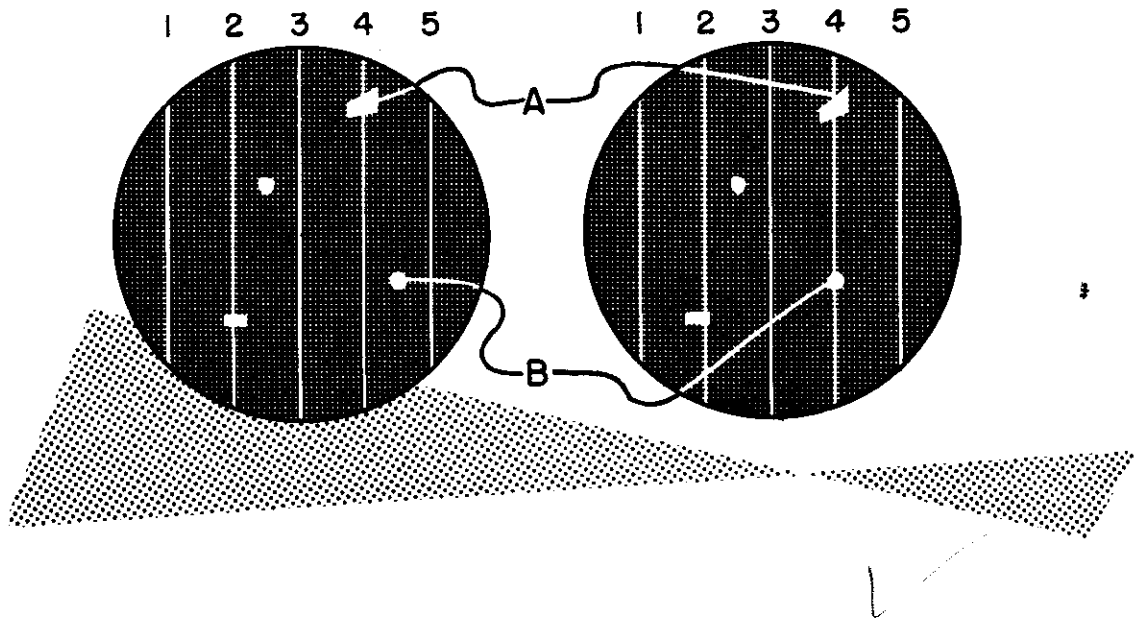

The display to the right is viewed by the right eye and the display to the left is viewed by the left eye. Target A is in the same location on both displays (not disparate) and will therefore be seen at a depth equal to the depth of the reference plane, i.e., the plane on which the lines are placed. Target B, however, is displaced to the left on the right hand display and to the right on the left hand display. The resultant disparity causes the target to appear above the reference plane when viewed stereoscopically. On the display illustrated above, therefore, the range and bearing of the target is displayed as on the conventional PPI, but the altitude (or any other desired dimension) is coded by the apparent depth of the target.

Little is known about the ability of observers to use stereoscopic coding. It is known that stereoscopic acuity (minimum disparity differences that observers can detect in apparent differences in depth) is affected by field brightness (Berry, Riggs, and Duncan, 1950), and by the size of the objects viewed (Mead, 1943). However, the number of stereo-depth steps that observers can learn to identify is unknown. It is certain that the number of absolutely identifiable stereo-depth steps will depend, in part, upon the size, definition, and brightness of the disparate images. For some practical considerations on this problem see Berkley, 1948; Schmitt, 1947; Parker & Wallis, 1948; and MacKay, 1949.

**Compound coding:** A singly coded signal is one that is coded by only one dimension such as by colors, shapes, or sizes. A compound coded signal is one which is coded by two or more methods, such as by colors, shapes, and sizes. By using compound codes more dimensions of information may be put into a display, but the complexity of interpretation also becomes greater. The recommendations concerning compounding of codes are as follows.

**Recommendations - compound coding:**

- (1) If only one dimension (say friend vs foe) is to be coded it should be coded by one code dimension. Compound coding of one dimension is usually less satisfactory if the single code used is the best available. (For example, red vs green is as satisfactory as large red circles vs small green squares).
- (2) If two or more dimensions are to be coded (say friend vs foe, and bomber vs fighter) the same number of coding dimensions should be used. Namely, do not use one coding dimension to code two dimensions of information. For example, do not use color to code all this information (such as red - enemy bomber, yellow - enemy fighter, green - friendly bomber, blue - friendly fighter) but preferably use, for example, color for friend (green) and foe (red), and shapes for bomber (cross) and fighter (circle). This latter method of coding allows for easier interpretation of the displayed information.

**Summary:** The selection of a code is limited by the nature of the information to be coded. With the exception of shape coding using numerals and letters the coding methods are greatly limited with regard to the number of identifiable steps. The space available for coded information also limits the freedom in selection of codes. The table below gives a summary of the coding methods discussed above.

SUMMARY TABLE OF CODING METHODS

Code Dimension	Number of Code Steps	Evaluation	Comments
Color	11	good	Objects of a given color quickly and easily identified in a field of various colored objects. Little space required.
Numerals & Letters	Unlimited	good	Number of coding steps unlimited. Requires little space if there is good contrast and resolution.
Geometric Figures	15 or more	good	Certain geometric shapes are easily recognized. Little space required if resolution is good.
Area	5	fair	Requires considerable space on display.
Visual Number	6	fair	Requires considerable space on display.
Length	4-5	fair	Limited number of usable code steps. Will clutter a display with many signals.
Angular Orientation	12	fair	95% of the estimates will be in error by less than 15°.
Brightness	3-4	poor	Limited number of usable code steps. Poor contrast effects will reduce visibility of weaker signals. Fatiguing.
Flash Rates	5	poor	Distracting and fatiguing. Interacts poorly with other codes.
Stereoscopic Depth	?	fair	Realistic method of coding range or altitude. Requires complex electronic displays.

*Baselines*  
chapter 4  
printed materials

## LEGIBILITY OF PRINTED MATTER

This section will cover the practices to be employed in the design of printed materials. The recommendations apply to books, pamphlets, graphs, tables, and also detailed instruction cards and decals that may be attached to equipment. (See also Paterson and Tinker, 1940.)

### BOOKS, PAMPHLETS, AND DETAILED INSTRUCTION CARDS

**Style of type:** Modern type faces such as Cheltenham, Antique, Garamond, Bodoni, Scotch Roman, etc., are equally legible, and the use of any of these is recommended. Cloister Black, American Typewriter, and Kabel Light are less readable than the above styles.

**Type form:** Do not print long passages in capitals. In cases where emphasis is desired it is permissible to print short passages in capitals, bold face, or italics.

**Type size:** The use of ten or eleven point type is generally recommended. However, nine or twelve point type is very satisfactory. (One point = .0138 inches.)

**Line length:** The optimal line length is about 19 picas. Avoid line lengths less than 14 or more than 28 picas. Long line lengths can be avoided by using two or more columns to a page. (One pica = .166 inches.)

**Leading:** Leading refers to the distance between lines. With ten or eleven point type the lines should have not less than two point leading.

**Paper:** Use a highly reflective matte paper in preference to glazed paper. Avoid thin transparent paper.

**Contrast:** Use black print on a white background.

**Space between columns:** If two or more columns of print appear on one page, the distance between the columns should be at least one pica. There should be no ruled lines between columns.

**Margins:** The margins at the top, outer, and bottom edges of the page should not be less than  $\frac{1}{2}$  inch. Larger margins are no assistance to legibility and waste space. However, the inner margin should be large enough so that printed material does not become hidden in the contours of the page entering the binding.

**Illumination:** For reading over extended periods of time (one hour or more) the illumination falling on the printed page should be 25 footcandles or more. However, brief passages of ten point type can be read at illuminances less than one footcandle. Detailed instruction cards attached to equipment may have to be referred to under conditions of low illumination (less than three footcandles) or through glass protecting the face of the reader. When such adverse reading conditions prevail, printed matter should have print size increased to 14 point or more.

**DECALS, CHECK LISTS, AND LABELS**

The legibility of instruction decals, check lists, and labels becomes a critical consideration when the operator is pressed for time in emergencies, and when under these circumstances he must operate infrequently used equipment. The recommendations that follow apply to instruction lists attached to the equipment or display panel.

**Style of print:** Capital letters should be used in preference to lower case because capital letters are readable at greater distances. The AND 10400 letters (see page 101) or any similar commercial forms such as Futura, Airport Semi Bold, or Demi Bold are satisfactory. The stroke width to height ratio should be from 1/6 to 1/8. The width to height ratio should be from three to five.

**Size of print:** The recommended letter size depends upon the reading distance and illumination conditions. Assuming a reading distance of 28 inches or less and a wide range of illumination conditions (including illuminances below one foot candle), the letter height should be at least .20 inches. For less critical functions or when the illumination is always above one footcandle the letter height may be reduced to .10 inches.

**Contrast:** In a cockpit in which dark adaptation is required the letters should be white on a dark background. This contrast relationship reduces the amount of light entering the eye. At stations where dark adaptation is not essential the print should be black on a highly reflective white matte background.

**Word selection:** Words and sentences are more immediately recognized as a function of the degree of familiarity the reader has with the words read. (Howes and Solomon, 1951.) Therefore, decals, check lists, and labels should be composed of words that are relatively common to the reader. However, you should use the common words in preference to very infrequent words only if the common words will say exactly what you intend to say. The best estimate of general population word familiarity is based on the Thorndike and Lorge 1944 word count. (See reference.) For particular populations, such as military pilots, common technical terms may be used even though these words occur infrequently for other populations.

**Brevity:** Emergency instructions and check lists should be made as concise as possible without distorting the intended information. This saves reading time and panel space. Below are examples of good and poor emergency instructions.

*NOT THIS*

*THIS*

**FOR EMERGENCY EJECTION IN  
FLIGHT JETTISON CANOPY BY  
PULLING THE CANOPY JETTISON  
HANDLE. HOOK HEELS IN FOOT  
REST. RAISE BOTH ARM RESTS  
TO HORIZONTAL POSITION.  
ASSUME ERECT POSTURE.  
ACTUATE EJECTION TRIGGER  
FOR SEAT EJECTION.**

**TO EJECT  
JETTISON CANOPY  
FEET IN STIRRUPS  
RAISE ARM RESTS  
SIT ERECT  
SQUEEZE TRIGGER**

printed materials  
graphs, tables, and scales

DESIGN OF GRAPHS, TABLES, AND SCALES FOR NUMERICAL DATA

Flight personnel are frequently required to use different mathematical functions during flight for such operations as cruise control, navigation, and bombing. The general techniques for presenting such information are by use of tables, graphs, and scales. These methods are depicted below. The general recommendations that apply to these techniques are also enumerated below. (Carter, 1946; Connell, 1947.)

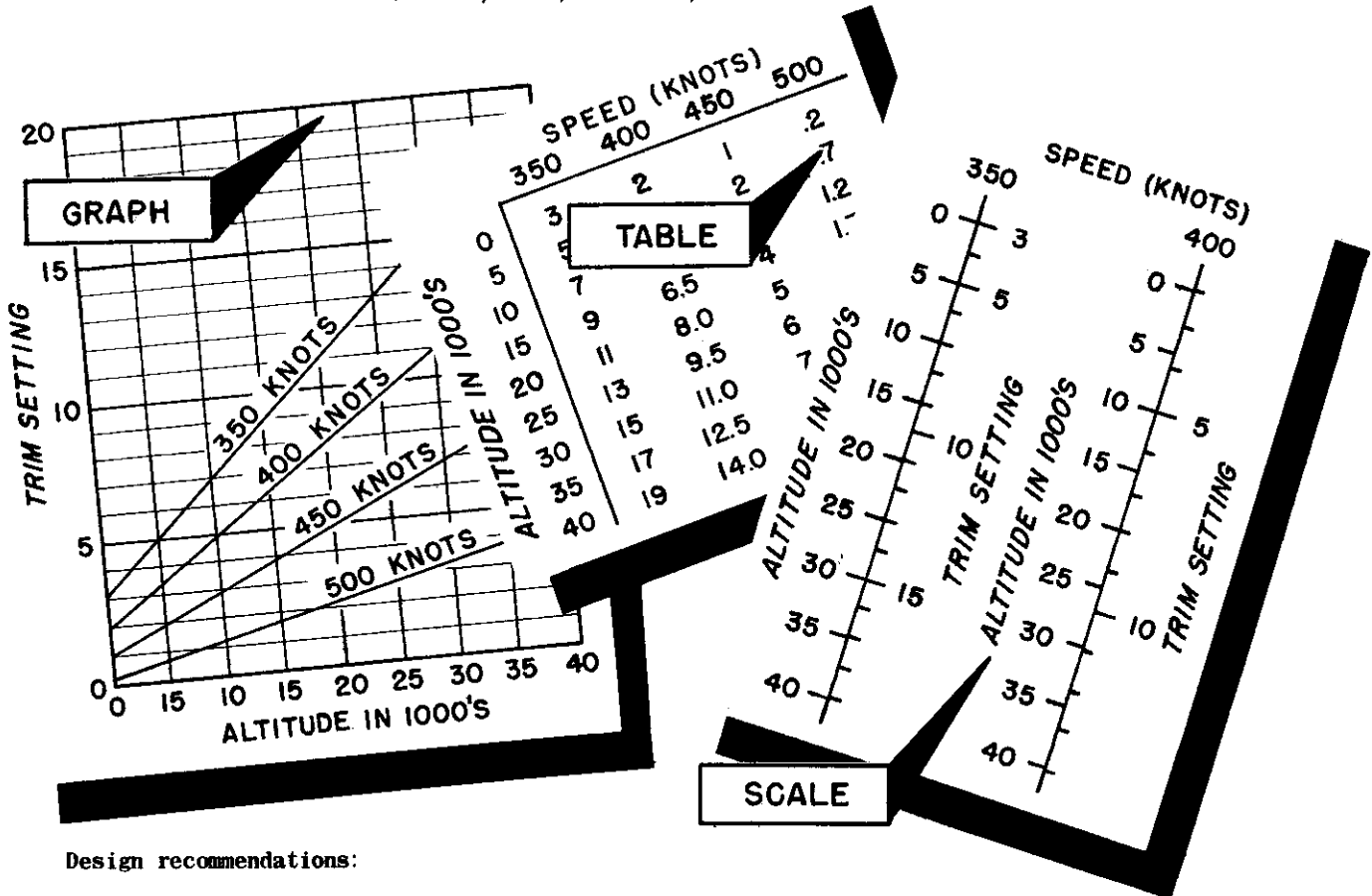

Design recommendations:

Tables should be reduced to the simplest form consistent with the degree of sensitivity required to permit reading without necessitating interpolation on the part of the reader. For example, if altitude steps of 5,000 feet (as shown above) are not sufficiently sensitive for the required accuracy, more altitude steps should be included in the table in preference to requiring the operator to interpolate values in the table.

Tables are preferred over graphs and scales for reading numerical data. However, if the general shape of the function is important in making decisions, a graph is superior. Also, if interpolation is necessary for any method selected, the graphic or scalar methods are superior to the tabular method. Graphs and scales are about equally good for reading numerical values.

The graphs should be constructed so that the numbered lines are bolder than the unnumbered lines. If ten line intervals are used between numbered lines, the fifth intermediate line should be less bold than the numbered lines but bolder than the unnumbered lines.

The recommendations that apply to scale numbering and graduation systems also apply to these types of scales and graphs. The scale recommendations are on pages 14-19.



**chapter 5**  
**instrument panel layout****CHECK LIST FOR GOOD PANEL LAYOUT**

The following list of desirable characteristics may be used as a check list for a well designed instrument panel.

**Any given instrument should be easy to find and identify.**

**The most important and frequently used instruments should have the most favorable position with reference to the normal line of sight.**

**Arrangement of the primary instruments should be consistent with other panels which the same operators may use in other aircraft or crew stations (standardized arrangement).**

**The instruments should be arranged in relation to one another to conform with the location of equipments to which they refer (engines, fuel tanks, etc.).**

**The manner of indication should be consistent for different instruments (for example, all pointers on circular scales move clockwise for increase).**

**All instruments should be readable from the normal head position of the operator, allowing for normal head rotation and restrictions imposed by helmets or other headgear. There should be no obstruction by other equipment, or occluding of dials because of oblique angle of view.**

**If control knobs are adjacent to the instrument they control (as is usually desirable) they should be so located that the hand normally used for setting will not obscure the indicator.**

**Instruments used most frequently should be grouped together to minimize eye movement distance in shifting from one instrument to another.**

The immediately following sections provide recommendations for achieving these desirable characteristics.

**REPRESENTATION OF PLANES IN SPACE**

Instrument panels are normally vertical and transverse to the longitudinal axis of the aircraft, although there may also be instruments on panels at other locations such as overhead, horizontal side panels, vertical side panels, and rearward facing panels. Regardless of the panel orientation, the relation of instruments to the location and motion of aircraft components must be that which is most natural to most operators. The relationship must also be standardized for all instruments and controls on the panel and for all panels for a given operator. This requires a standardized representation of three-dimensional relationships on two-dimensional panels. Some dimensions must be represented on planes of space which are rotated or translated up to 90° from the true planes.

#### TYPES OF SPACE RELATIONS TO BE REPRESENTED

**Linear:** Up-down, right-left, and fore-aft. This is important primarily for the position of instruments relative to one another so that they correspond with the position of aircraft components (engines, fuel tanks, flaps, generators, etc.).

**Rotational:** Right or left turn, right or left bank, and nose up or down. This is important primarily for the design and mounting of instruments (heading, bank, trim tab position, etc.).

#### REPRESENTATION OF SPACE RELATIONS FOR OPERATORS IN VARIOUS POSITIONS

The diagrams on the following pages show the recommended linear and rotational space representations for forward, right, left, and rearward facing operators. In general it may be stated that rearward facing operator positions are not recommended for complex stations, such as that for flight engineers where much equipment that directly affects the aircraft is controlled.

**Sloping and diagonal panels:** Panels may be sloping or mounted at angles deviating from the planes shown in the diagrams on the following pages. In such a case the plane (in the diagrams) which the panel most closely approximates should be used as the guide. In other words, the recommendations may be followed for deviations up to  $45^{\circ}$  from the true planes as shown in the diagrams. In cases where two or more portions of a single panel have different slopes, the average slope should determine the representations which are used.

**Ambiguous and undesirable rotation of space representation:** Whenever possible, two or more instruments should be arranged along a line which is approximately parallel to a line running through the aircraft components to which the instruments refer. Likewise an instrument movement which relates to aircraft motion should be in approximately the same plane as the aircraft motion. In both of these cases deviations up to  $30^{\circ}$  are acceptable. In many cases, however, deviations or rotations up to  $90^{\circ}$  are unavoidable. Indeed, for rearward facing panels,  $180^{\circ}$  rotations may be advisable. Some such rotations are more acceptable than others. In the following diagrams all  $90^{\circ}$  rotations are indicated. The  $90^{\circ}$  rotations and other representations that are considered least acceptable are indicated by question marks. Other possible representations not shown in the diagrams are not acceptable and should not be used. It is recommended that questionable representations be avoided by installing the equipment on panels in other planes whenever possible.

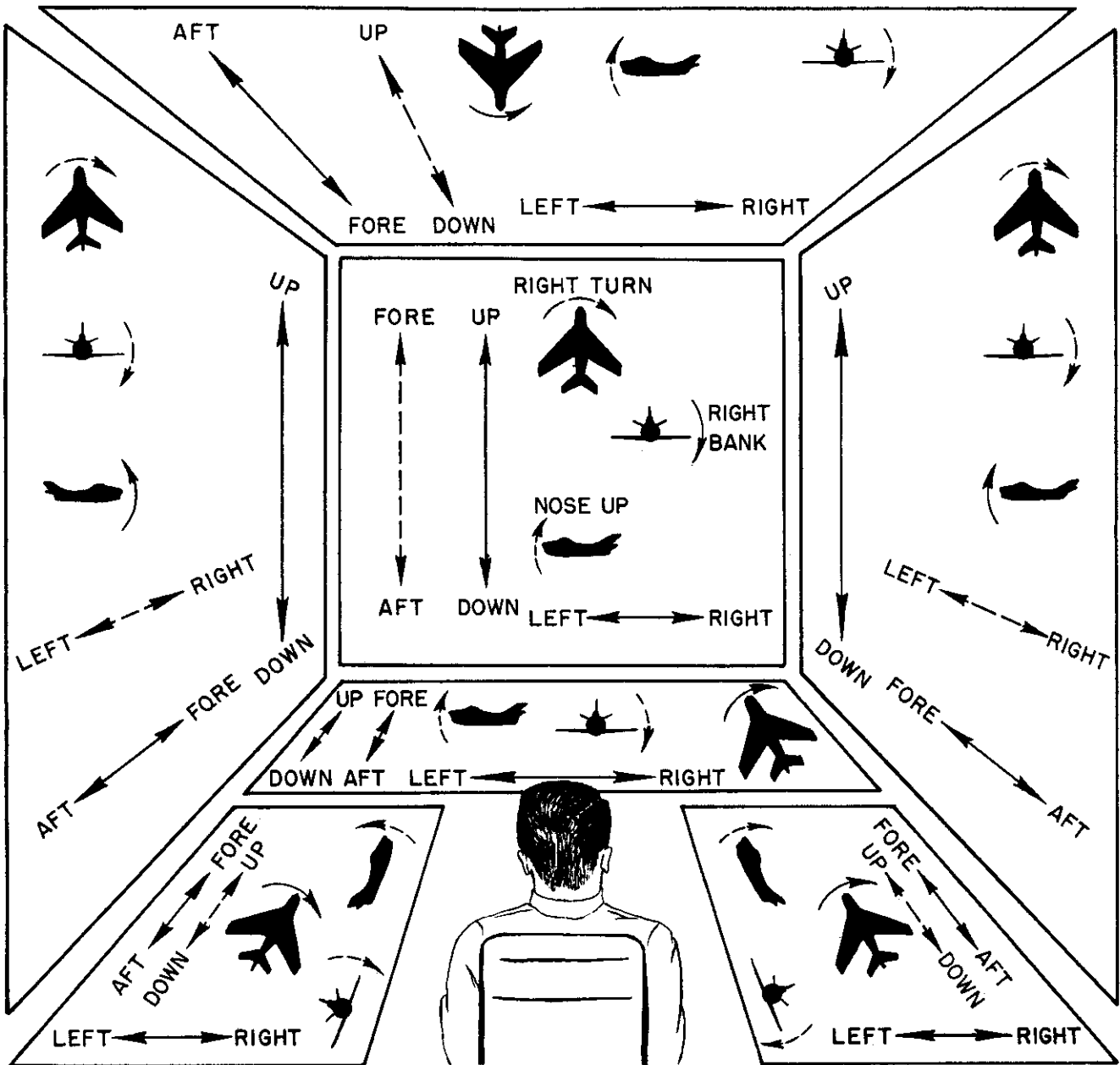

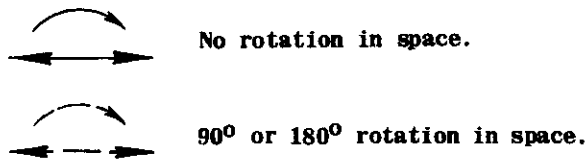

REPRESENTATIONS OF SPACE RELATIONS FOR FORWARD AND AFTWARD FACING OPERATORS\*

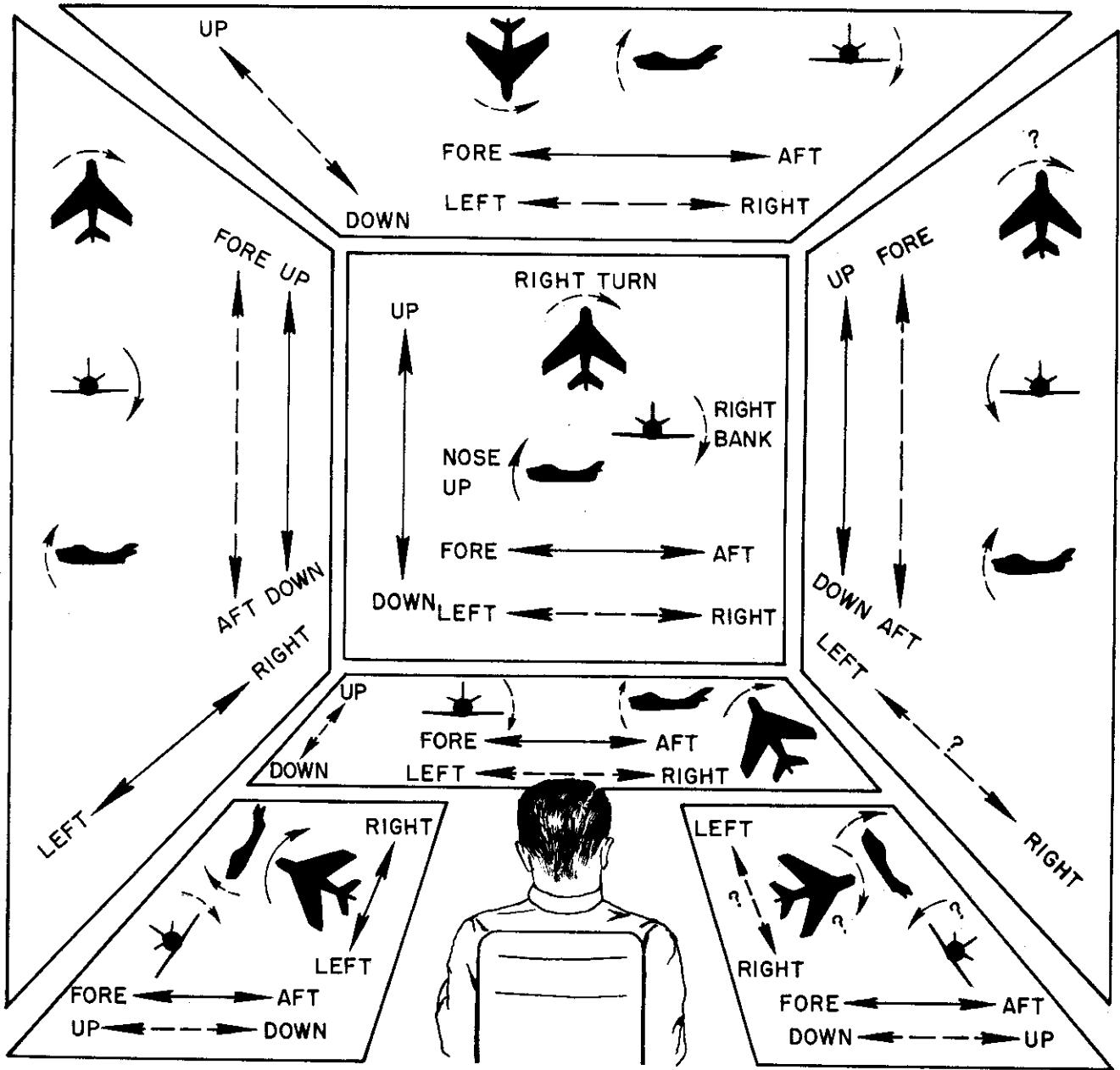

\*The vertical panel in front of the operator is identical for both forward and aftward facing operators. However, the fore-aft relation should be reversed for all other panels for the aft facing operator. It should be noted that the left-right relations are 180° rotated on some panels for the aft facing operator. Such rotations are highly questionable, and for this reason the aft facing stations should be avoided.



**REPRESENTATIONS OF SPACE RELATIONS  
FOR RIGHTWARD FACING OPERATORS**

-  No rotation in space.
-  90° or 180° rotation in space.
-  ? Questionable and should be avoided.

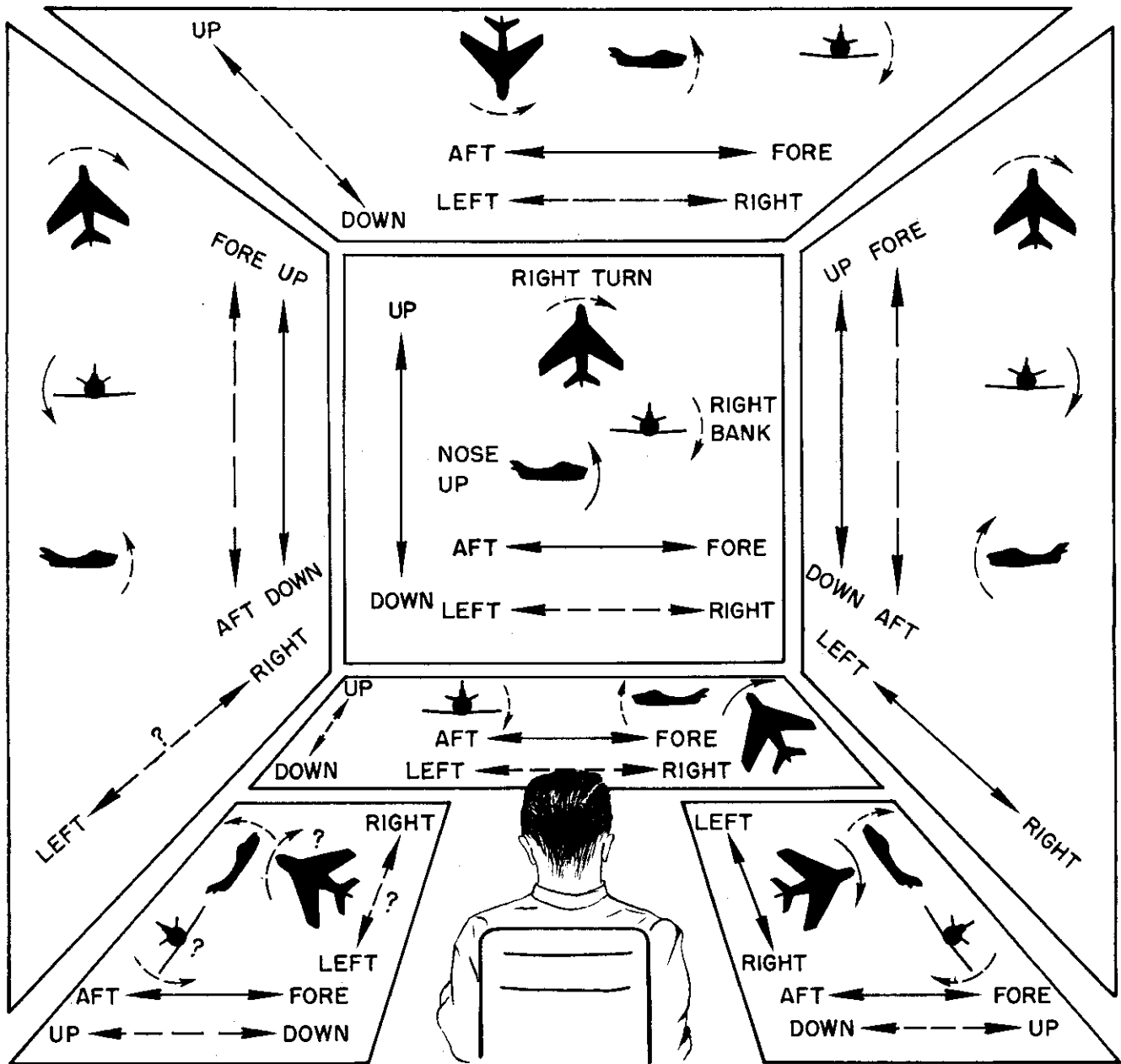

**REPRESENTATIONS OF SPACE RELATIONS  
FOR LEFTWARD FACING OPERATORS**

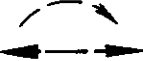
-  No rotation in space.
-  90° or 180° rotation in space.

? Questionable and should be avoided.

## INSTRUMENT PRIORITY, POSITION, VIEWING ANGLE, AND DISTANCE

**Optimum Position:** In general, the optimum location for instruments is directly before the operator from eye level to about  $30^\circ$  below eye level. For pilots or other vehicle operators, the optimum location is just below the windshield. The most important and frequently used instruments should be placed in this most favorable area. Instruments used for controlling direction (such as aircraft heading indicators) are preferably located directly ahead of the operator. If there are two or more such direction instruments they are preferably arranged along a vertical line.

**Viewing Angle:** The most favorable angle for viewing instruments is perpendicular to the dial faces. Extremely oblique viewing angles should be avoided by angling the ends, bottom or top of large panels. Viewing angles up to  $45^\circ$  are considered

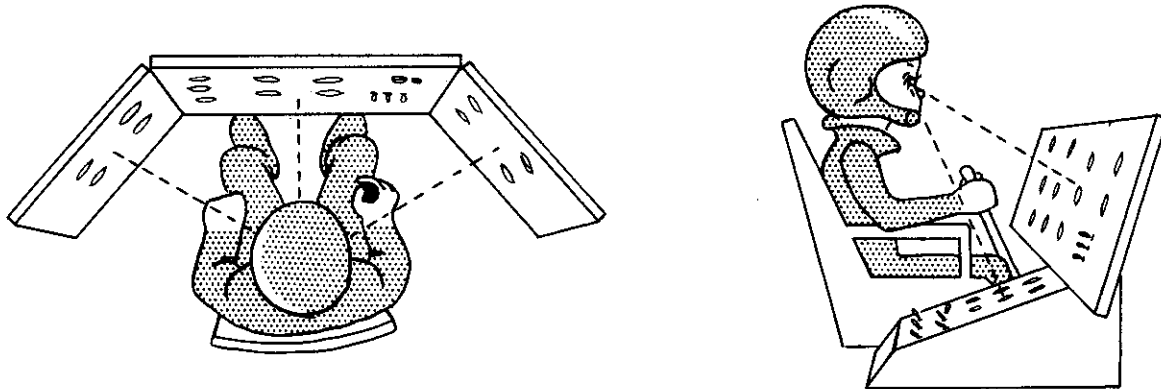

satisfactory, provided needed information on the dial is not obscured by the bezel, lighting shield, or other obstruction, and if some loss of reading precision due to parallax can be tolerated.

**Viewing Distance:** Viewing distance for instrument panels need be limited only if the operator is required to manipulate knobs or switches on the panel from his normal seated position. This distance is normally fixed at 28 inches from the eyes for vertical panels. The instrument size must be increased proportionally for longer viewing distances.

**Horizontal and Vertical Separation:** The difficulty of shifting between instruments increases with separation distance. Vertical eye movements are more difficult than horizontal shifts in fixation. Distance between instruments should be minimized. Horizontal separations are preferred to vertical separations. (Fitts and Simon, 1952.)

**Position of Adjusting Knobs and Switches:** Setting knobs and switches should be located so that (1) the operator's hand does not obscure the indicator being adjusted, and (2) the most natural control-indicator movement relationship is obtained (see pages 11 to 14).

**Right Handed Operation:** Knobs and switches most likely to be operated with the right hand (at center or right of panel) should be located below or to the right of the associated indicator.

**Left Handed Operation:** Knobs and switches most likely to be operated by the left hand (at extreme left of panel) should be located below the associated indicator.

**INSTRUMENT ARRANGEMENT AND POINTER ALIGNMENT FOR EASE OF CHECK READING**

Some indicators (such as engine instruments) maintain stable values for given operating conditions, and are used primarily for monitoring purposes. Readings are of special interest only when they deviate from desired values. Reading of such instruments is aided if they are arranged in rows and columns, with horizontal pointer alignment as shown below.

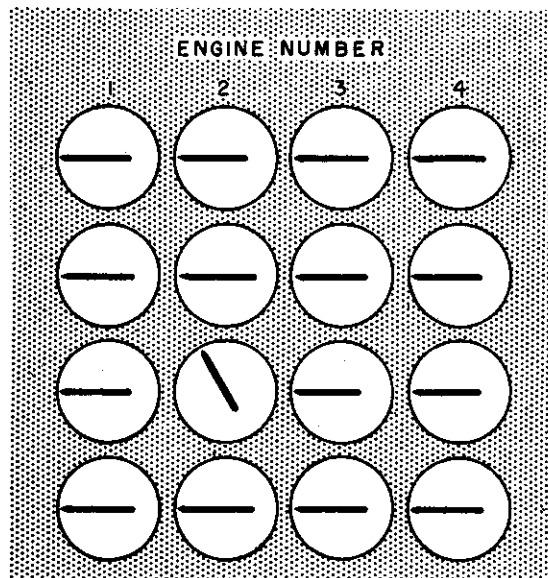

The pointer tips should be aligned at the 9 o'clock position for the most critical reading condition. For aircraft engine instruments the pointers should be aligned at take-off power. (Warrick and Grether, 1948; White, 1951.)

By making the instruments rotatable, and providing suitable adjusting knobs (one for each row of identical instruments) the pointers can be aligned for any desired operating condition. This is not recommended for general use because of (a) the complication of the panel construction, (b) the additional adjustment required of the operator, (c) the variability in pointer angle for a given numerical reading.

### COMBINATION OF INSTRUMENTS

Frequently more than one indication is presented within a single instrument. The advantages are saving of panel space, economy of eye movements, and simplification of interpretation. Although these are real advantages, there are also disadvantages which limit the number of indications which can profitably be combined. The disadvantages are: (1) compression of several indications into a small area, particularly if they are superimposed, makes identification of the desired information more difficult; (2) continued eye fixation on a single point or small area may produce an hypnotic effect and reduce the alertness of the operator; (3) some techniques of instrument combination, involving mirrors or optical projection, greatly restrict the eye position of the operator and require artificial lighting, even in daylight; and (4) many types of combinations introduce penalties in reliability, maintenance, and cost.

### RECOMMENDED TYPES OF COMBINATION

Aside from the obvious advantage of saving panel space, the primary consideration should be simplification of the operator's task in reading and interpreting the information being presented. Desirable and potentially successful types of combinations are described below.

**Combination of Related Types of Information:** In the example to the right, indicated airspeed, true airspeed and Mach number are combined. All of these are closely related. For flight control, indicated airspeed is used at slow speeds and Mach number at high speeds.

In the illustration to the right (Radio Magnetic Indicator), two radio compass needles are superimposed over a magnetically slaved rotating card. Magnetic heading to a station can be read directly under the radio compass needle tuned to that station. From the angles formed by the two radio compass needles the pilot can estimate his ground position and course in relation to the two ground stations.

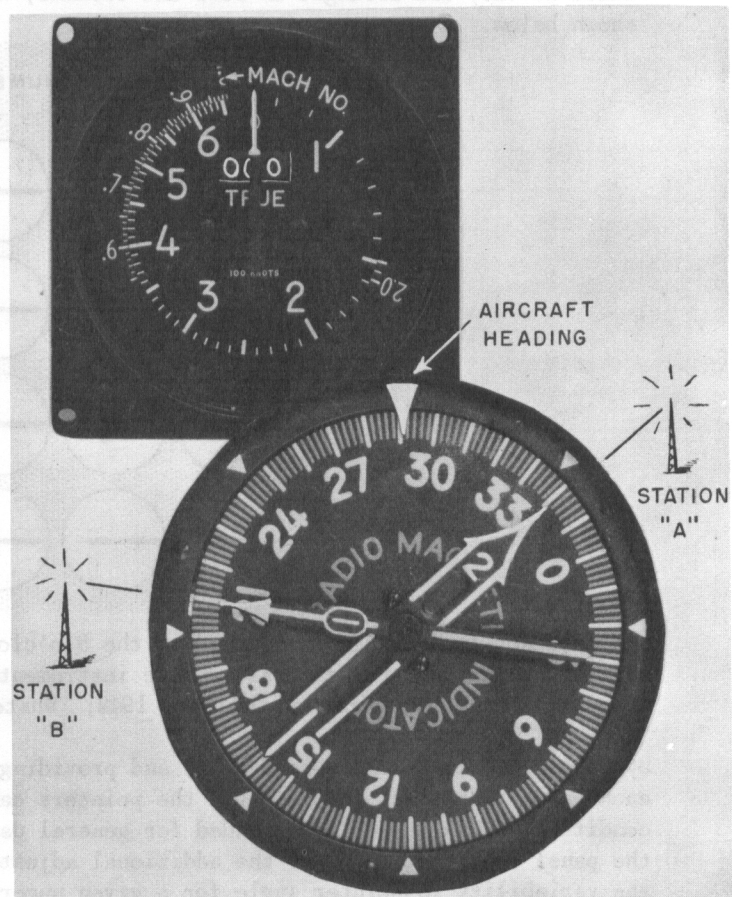



**Moving Reference Pointers:** It is sometimes possible to use one pointer as a moving reference for alignment of a second pointer. The ID-249 shown below illustrates such an application. If the pointer tip of the relative heading indicator is kept aligned with the localizer needle, aircraft will approach the desired localizer track in an asymptotic path. Matching of pointer positions is easier than integrating the two readings when presented on separate indicators.

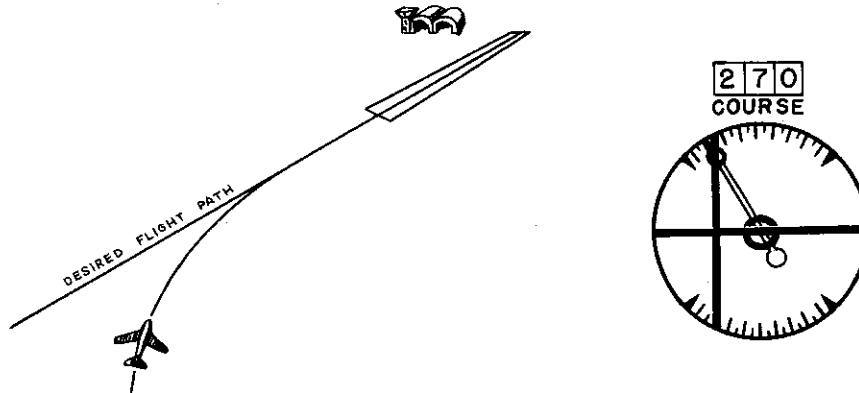

This type of combination is most applicable when one indication is the first derivative of the other. In the example above the localizer pointer shows aircraft position relative to a radio beam. The relative heading indicator defines the rate at which the aircraft approaches or leaves the localizer track. Thus relative heading is the first derivative of position, as shown by the localizer pointer. Rate, in this case heading, is more easily controlled by the pilot than position. The goal of the pilot is aircraft position. But this is accomplished by controlling heading, which is under more direct control and responds with much shorter lag. The result is improved performance with less effort by the operator. In applications of this type the pointer being controlled directly by the operator should present the first derivative of the data indicated by the moving reference. The success of such a combination will depend upon a proper movement ratio between the two values being indicated. This must be determined for each such application.

**Combination of Separate Values Into Single Indication:** In some cases it is possible to present a single computed indication which is an optimum combination of several separate values. The aircraft Zero Reader shown below is such a combination. In this instrument the vertical pointer presents an electrical combination

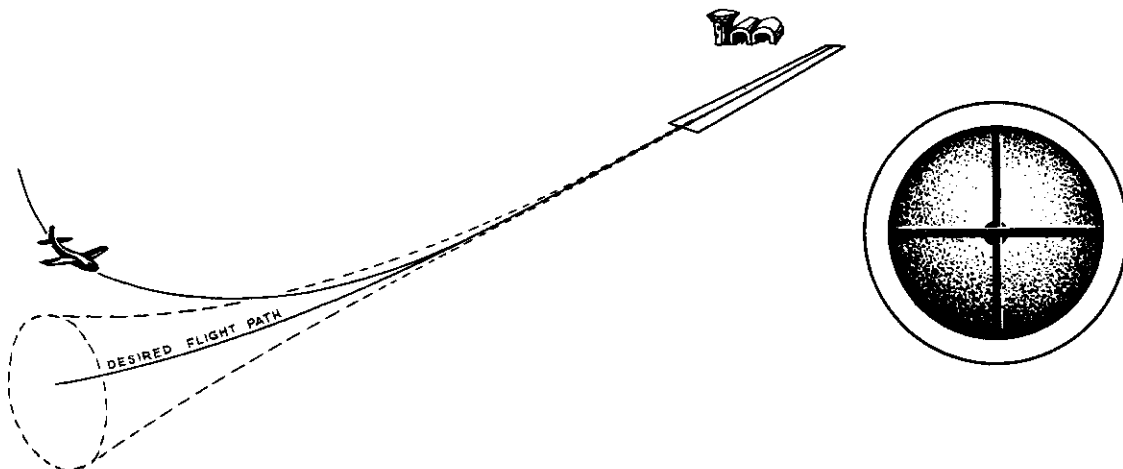

of position relative to the localizer path, relative heading (first derivative), and angle of bank (second derivative). The horizontal pointer presents a combination of position relative to the glide path and aircraft pitch (first derivative). By keeping the two pointers centered (zeroed) the operator flies the aircraft so as to make asymptotic approaches to the desired localizer and glide paths. The localizer pointer can be centered by controlling angle of bank, and the glide path pointer can be centered by controlling pitch. Both of these are rather easily controlled, and involve minimum lag. This simplifies the pilot's task considerably in flying an Instrument Landing System (ILS) approach, and results in improved performance on the landing approach.

This type of combination appears particularly suitable where the first and higher order derivatives can be combined with the basic value which the operator is trying to reach or maintain. The number of derivatives to be combined, and the ratios to be used in the combination must be determined for each application. Different types of aircraft, or different types of flight operation, may require different ratios.

A disadvantage of this type of combination is that the individual values are lost to the operator unless presented also as separate indications. By keeping the pointers zeroed the operator will achieve the desired end result, but he is not shown the details of how this is accomplished. In the case of the Zero Reader he does not know his exact flight path, as might be required for clearance of ground obstacles. Where necessary for safety reasons the operator must also be provided with the separate indications on other instruments, in addition to the electrically combined indication.

LIGHTING

Efficient use of vision in the operation of equipment dictates certain illumination requirements. These requirements vary from very low levels of illumination of a specified color, as on the bridge of a ship or in an aircraft cockpit, to high levels of white illumination found in offices and machine shops. The purpose of this section is to provide background information on illumination principles as well as specific lighting recommendations.

DEFINITION OF TERMS

**Photometry:** Photometry is the measurement of light, that is, the measurement of radiant energy in terms of its effect on the human eye. Photometric measures are made by comparing an unknown light source with a known light source using the eye (or photocell which has the same spectral sensitivity as the eye) as a null indicator. Radiometry, on the other hand, is the measurement of radiant energy in purely physical terms. This section on lighting is concerned only with photometric measures. The following photometric terms are those in current usage in the Illuminating Engineering Society Lighting Handbook, 1952.

**Illumination:** (Illuminance) The areal density of the light falling on a surface. The most common unit of measurement is the footcandle.

**Candle:** The unit of light intensity of a point source. It is an internationally agreed-upon standard which is the basis for all other illumination and brightness units.

**Footcandle:** The illumination falling on the inner surface of a sphere one foot in radius with an international candle at its center. The following inverse square relationship applies to point sources of light:

$$\text{Illumination (ft-c)} = \frac{\text{candles (point source)}}{\text{Distance (feet) squared}}$$

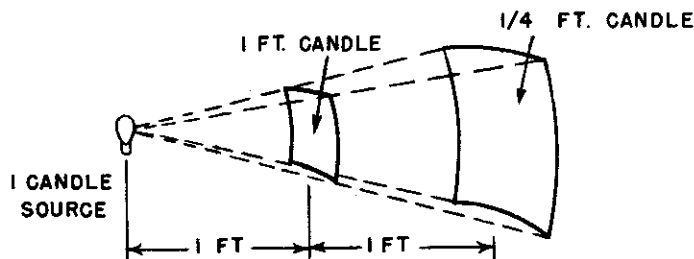

**Lumen:** The unit of light. It is defined as the flux per unit solid angle (steradian) emitted by a point source of one candle. One lumen per square foot is equivalent to one footcandle of illumination.

**Brightness:** (Luminance) Brightness refers to the amount of light emitted by or reflected from a surface in a specified direction. The brightness of a surface may be expressed by the following methods:

**Candles Per Unit Area:** The surface may be considered as a light source and its brightness expressed in terms of candles per unit area of surface. The recommended unit is candles per square centimeter but other dimensions of surface area are also permissible. (See conversion table on page 73.)

**Footlambert:** (ft.L., also apparent footcandle) A unit of brightness equal to the brightness of a perfectly diffusing and reflecting surface illuminated by one footcandle. This is the recommended unit of measurement for most purposes.

**Lambert:** A unit of brightness equal to the brightness of a perfectly diffusing and reflecting surface illuminated by one centimeter-candle, i.e., emitting one lumen per square centimeter.

**Millilambert:** A common unit of brightness equal to 1/1000 of a lambert. It is roughly equal to a footlambert. (See conversion table on page and see also the table of approximate brightnesses on page 74.)

**Luminous Reflectance:** When light beams incident to a surface are redirected we speak of reflectance. There are several kinds of reflectance:

**Diffuse:** If the surface is composed of rough, irregular particles the reflection of the incident light is diffuse.

**Specular:** Incident light on a polished surface such as a mirror will be reflected at an angle equal to the angle of incidence. Such reflection is specular.

**Compound:** Most surfaces actually encountered have both specular and diffuse reflectance characteristics. These surfaces are compound reflectors.

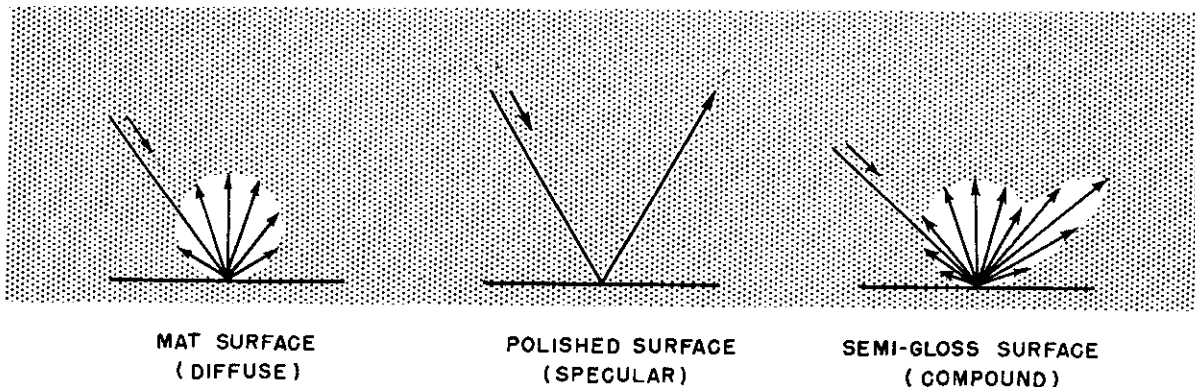

**Reflectance Factor:** The reflectance factor refers to the percentage of incident light that is reflected. Surfaces with compound reflectances may have reflectance factors for both diffuse and specular reflectance.

**Transmittance Factor:** As light passes through a medium some may be absorbed and some reflected back. The transmittance of such media (filters, etc.) is expressed as the percent of incident light transmitted.

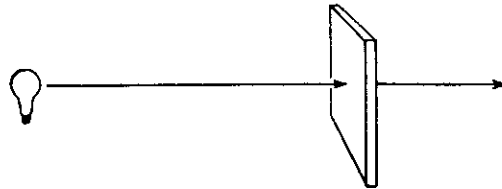

**Selective Reflectance:** Object color results from selective reflectance and selective absorption of particular wavelengths of incident light. A red object appears red because the longer wavelengths (red) are reflected and the shorter ones (blue) are absorbed in the surface. It is obvious, therefore, that perfect reflectors cannot have object color other than white. Selective or spectral reflectance is specified by the percent reflected light at arbitrary wavelength steps (usually 50 Angstroms) as seen in the diagram below.

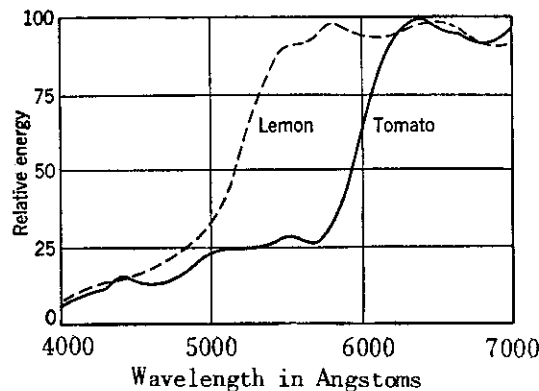

**Selective Transmittance:** A transparent or translucent medium may selectively absorb or transmit light as a function of wavelength. A red filter, for example, absorbs energy from the blue end of the spectrum and transmits the longer wavelengths. The spectral transmittance of a filter is usually plotted in a manner similar to the graph immediately above.

lighting  
contrast - visual acuity

**Brightness contrast:** Brightness contrast refers to the percent brightness difference between a viewed object and its immediate background. It is expressed as follows:

$$\text{Contrast (\%)} = \frac{B_1 - B_2}{B_1} \times 100 \text{ in which } B_1 \text{ is equal to the greater brightness.}$$

It is sometimes expressed as  $\frac{B_o - B_b}{B_b} \times 100$  in which case the  $B_o$  is the object brightness and  $B_b$  is the background brightness.

**Visual angle:** The visual angle is the angle subtended at the cornea of the eye by the viewed object. It is determined as follows:

Visual angle =  $2 \arctan \frac{L}{2D}$   
in which L is the size of the object measured perpendicularly to the line of sight. D is the distance from the eye to the object.

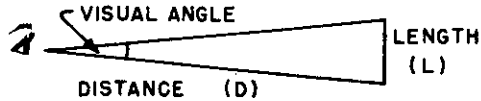

**Visual acuity:** The size of detail which the eye is capable of resolving is used as a measure of visual acuity. Visual acuity is measured by determining the smallest visual angle that can be resolved. It is usually specified as the reciprocal of the minimum visual angle expressed in minutes of arcs.

$$\text{Visual acuity} = \frac{1}{\text{visual angle}}$$

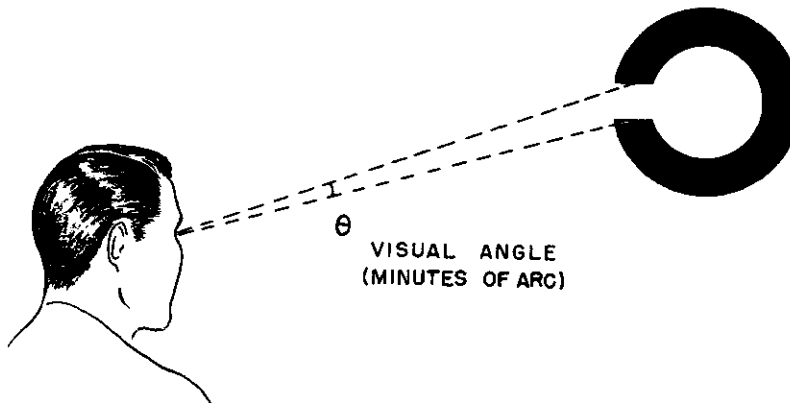

**CONVERSION FACTORS FOR BRIGHTNESS UNITS**

	<b>Ft.-L</b>	<b>L</b>	<b>mL</b>	<b>C/in<sup>2</sup></b>	<b>C/ft<sup>2</sup></b>	<b>C/cm<sup>2</sup></b>
<b>Foot-Lamberts</b> (Apparent or equivalent foot candles)	1.0	$1.076 \times 10^{-3}$	1.076	$2.210 \times 10^{-3}$	$3.183 \times 10^{-1}$	$3.426 \times 10^{-4}$
<b>Lamberts</b>	$9.290 \times 10^2$	1.0	$1 \times 10^3$	2.054	$2.957 \times 10^2$	$3.183 \times 10^{-1}$
<b>Millilamberts</b>	$9.290 \times 10^{-1}$	$1 \times 10^{-3}$	1.0	$2.054 \times 10^{-3}$	$2.957 \times 10^{-1}$	$3.183 \times 10^{-4}$
<b>Candles per Square Inch</b>	$4.524 \times 10^2$	$4.869 \times 10^{-1}$	$4.869 \times 10^2$	1.0	$1.440 \times 10^2$	$1.550 \times 10^{-1}$
<b>Candles per Square Foot</b>	3.142	$3.382 \times 10^{-3}$	3.382	$6.944 \times 10^{-3}$	1.0	$1.076 \times 10^{-3}$
<b>Candles per Square Centimeter</b>	$2.919 \times 10^3$	3.142	$3.142 \times 10^3$	6.45 <sup>2</sup>	$9.290 \times 10^2$	1.0

Value in Unit in Left Hand Column Times the Conversion Factor Equals the Value in Unit Shown at the Top of the Column.  
(See also the table of approximate brightnesses on page 74.)

lighting  
table of brightnesses

TABLE OF APPROXIMATE BRIGHTNESSES

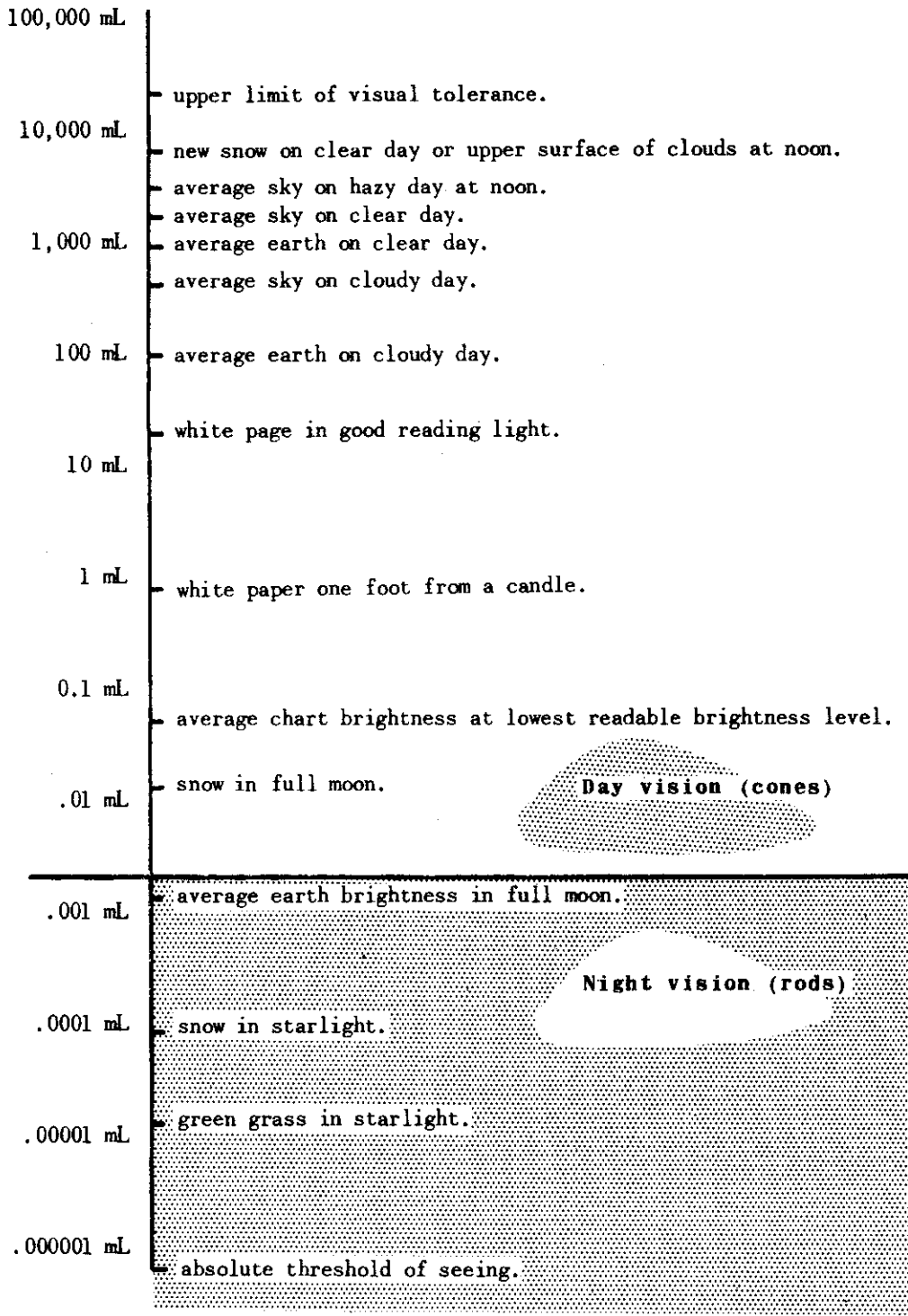



**GENERAL WORKPLACE LIGHTING**

Adequate lighting is essential for efficient vision. The most important considerations in lighting are (1) the absolute intensity of the illumination, (2) the distribution of light in the working areas, (3) the brightness contrasts of the viewed objects and their details, and (4) the quality and color of the illuminants and surfaces.

The literature in this area is considerable. Unfortunately, agreement on many points among workers in this field is lacking. Many of the following recommendations are compromises.

**ILLUMINATION LEVELS**

The desirable levels of illumination for various visual tasks are somewhat controversial. However, it is generally agreed that illumination requirements are greater with (1) smaller detail requiring greater visual acuity, (2) longer periods of visual work, (3) lower contrast of the viewed objects to be discriminated, and (4) lower reflectances of the viewed objects. The table below contains recommended illumination levels for various tasks. The IES Lighting Handbook, 1952, contains many specific task illumination recommendations.

<b>RECOMMENDED ILLUMINATION LEVELS</b>	
<b>Working Condition</b>	<b>Footcandles Illumination</b>
Very difficult and prolonged visual tasks with objects of low brightness contrast such as sewing and inspection of dark materials.	100 or more
Fine machine work, detail drafting, watch repairing, and inspection of medium materials.	50 or more
Prolonged reading, assembly, general offices, ordinary bench work, and laboratory work.	25 or more
Occasional reading, washrooms, power plants, waiting rooms, and kitchens.	10 or more
No detail vision, restaurants, stairways, and bulk supply warehouses.	5 or more

**GENERAL METHODS OF LIGHT DISTRIBUTION**

The distribution of light in the working areas should be planned with consideration to reducing glare and shadows and to providing optimal brightness ratios. The general methods of lighting are illustrated below.

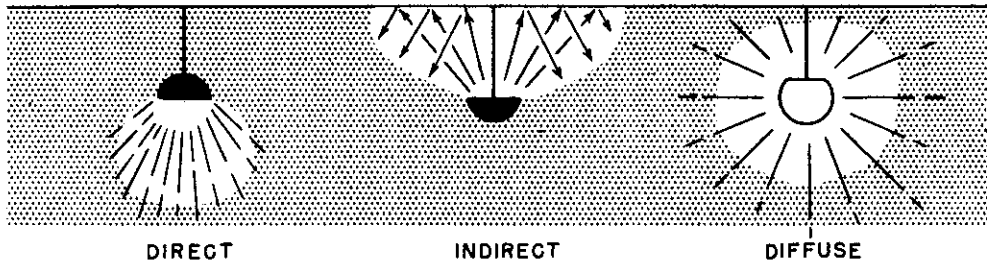

**Direct luminaires:** The light is directed upon the working surface. When used singly as the sole source of illumination they produce glare and undesirable shadows. Not recommended. However, such sources may be used to supplement diffused light from other sources. They may also be used with many other similar sources if located on a relatively high ceiling over the work area. This arrangement results in a general diffusion of light over the work surfaces.

**Indirect luminaires:** The lighting fixtures direct the light largely upon the ceiling and upper wall surfaces. With high reflectant, flat (non-glossy) paint on these surfaces diffuse lighting results. This system minimizes glare and undesirable shadows. Indirect luminaires are recommended for use when practicable.

**Diffuse luminaires:** Such sources give both direct and diffuse lighting. If they are spaced relatively close together on a high ceiling good illumination is obtained.

**GLARE**

When a relatively bright light source or its reflected image appears in the visual field decreased visibility results. Glare not only reduces visibility for objects in the field of view, but causes visual discomfort.

**Direct glare:** Refers to a light source within the visual work field.

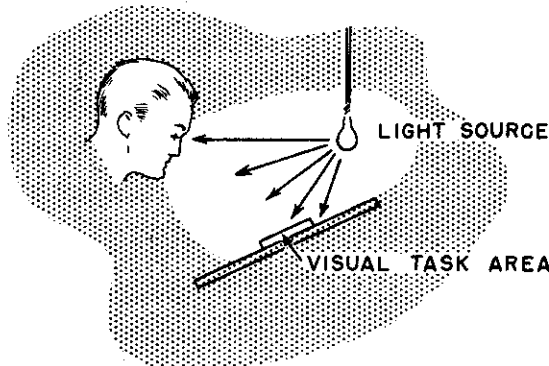

**Specular glare:** Refers to reflecting bright surfaces within the visual field.

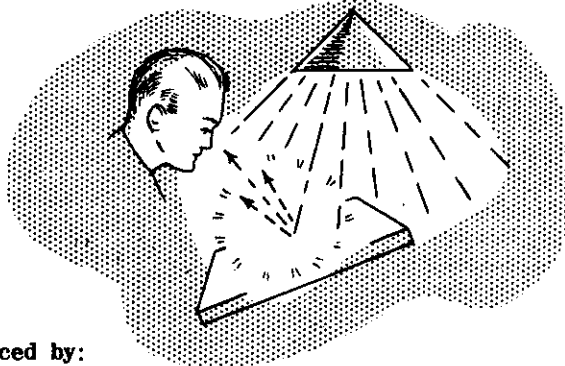

**Direct glare is reduced by:**

1. Avoiding bright light sources within  $60^\circ$  of the central visual field. Since most visual work is on or below a horizontal level from the eye direct luminaires placed high above the work area minimize direct glare.

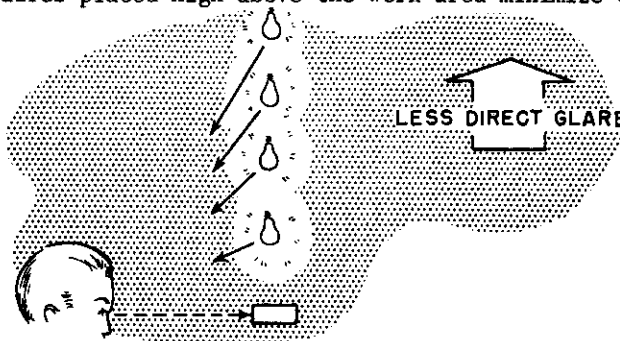

2. Using indirect lighting.
3. Using numerous low intensity sources rather than a few intense ones.
4. Using shields, hoods, and visors.

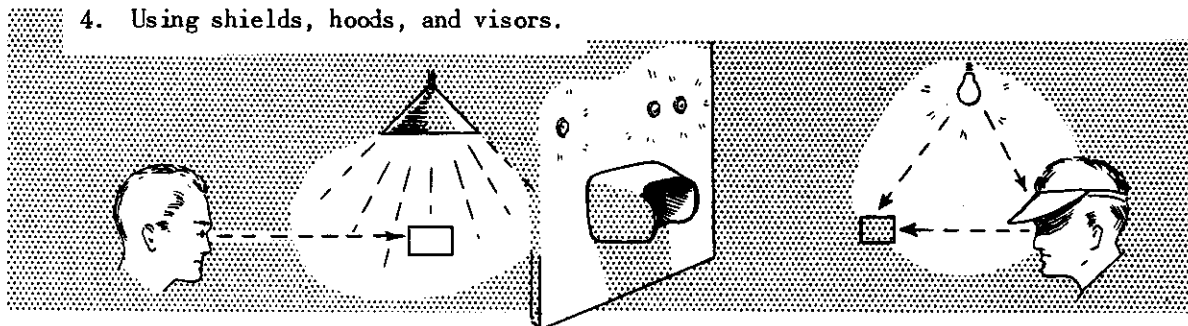

**Specular glare is reduced by:**

1. Using diffuse light.
2. Using surfaces that diffuse rather than specularly reflect incident light. Mat surfaces (flat paints, desk blotters, etc.) reduce specular glare.

3. Arranging direct light sources so that the viewing angle of the visual work area is not equal to the angle of incidence from the source.

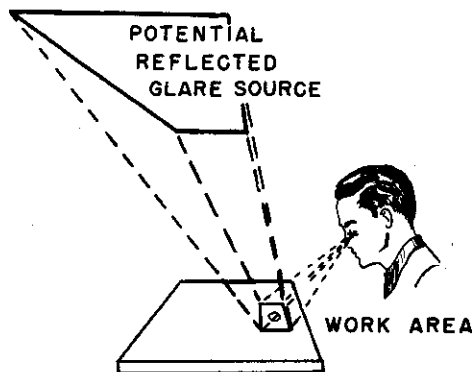

#### SURROUND BRIGHTNESSES

The surround brightness refers to the brightness of the areas immediately adjacent to the area of visual work. The page of this book is the present visual task area and the desk top is the immediate surround. (See diagram)

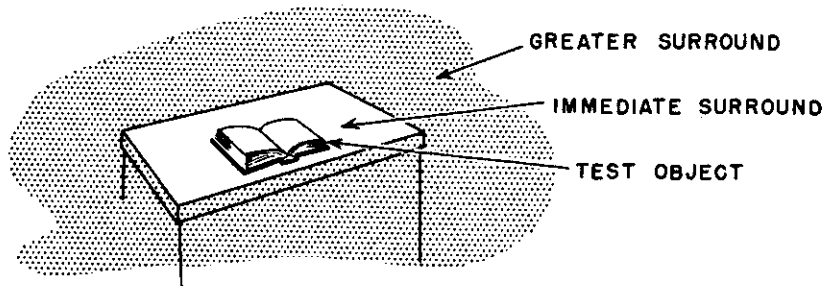

The surround brightness should not be brighter than the brightness of the visual task area.

The surround brightness should be at least 10 percent as bright as the visual task area brightness.

These recommendations imply that the sole source of illumination should not fall exclusively on the visual work area. There should be some illumination falling on the surrounding areas. It is more important that the surround should be no brighter than the central work field. The surrounding surfaces should have reflectance factors no higher than the objects in the central work field when both areas are equally illuminated.

#### TYPES OF ILLUMINANTS

The selection of an illuminant may be made from a number of commercially available ones. The most common types are tungsten-filament incandescent, mercury arc,

sodium vapor, and fluorescent luminaires. For all practical purposes they are equally effective for visual performance if exacting color discrimination is not required. However, some objections have been raised concerning fluorescent lighting. (Holway and Jameson, 1947) Individuals working under fluorescent lights complain that it is thin, harsh and cold. It is considered unpleasant and distracting.

In some cases it is desirable that the illuminant approximate daylight. This is particularly true when exacting color discrimination is required as in grading or sorting materials where color is a major cue. Consult the IES Lighting Handbook for daylight simulators.

**SURFACE REFLECTANCE AND COLOR**

The reflectance of ceilings, walls, floors, and furnishings or machinery contribute significantly to the general illumination level. For any specified level of illumination, a work space with highly reflecting surfaces requires less intense light sources than one with low reflecting surfaces. The following diagram illustrates the general recommendations concerning the reflectances for surfaces in offices, study rooms, machine shops, power stations, etc.

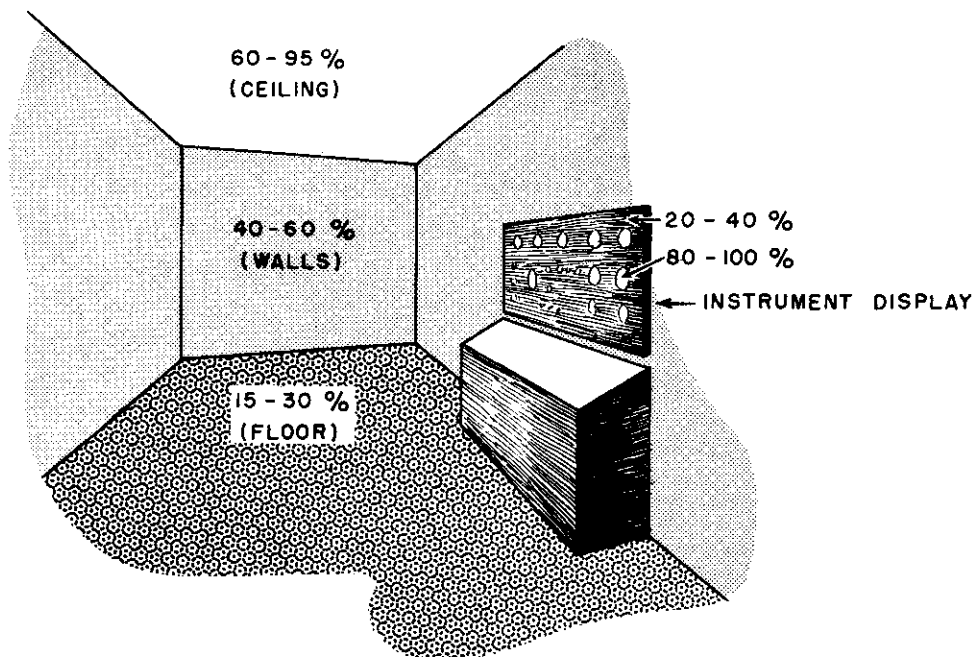

Large surfaces such as walls and desk tops should be non-glossy to reduce specular reflections. Smaller areas such as door frames and moldings may be glossy to permit easy cleaning.

Saturated colors should not be used on large surfaces. Tints, pastels, and warm grays are generally recommended.

**lighting  
equipment color coding**

**SPECIFIC COLOR CODING RECOMMENDATIONS**

The American Standards Association (Z53.1-1953) recommends the use of certain colors for coding physical hazards and certain equipment. Below is a summary of the recommendations. For a more detailed coverage consult the American Standard Z53.1-1953.

**Red:** The basic color for the identification of:

**Fire Protection Equipment.** (Alarm boxes, fire extinguishers, fire buckets, fire hose connections, sprinkling valves, industrial fire hydrants, etc.)

**Danger.** (Safety cans with flammable contents, barricades and obstructions, and danger signs.)

**Stop.** (Stop bars on hazardous machinery, stop switches for emergency stopping of equipment, etc.)

**Orange:** The basic color for designating dangerous moving parts of machines or starting switches and levers of machinery with exposed hazards. (Inside of guards for gears, pulleys, chains, exposed gears, cutting edges, and pulleys, safety starting buttons, etc.)

**Yellow:** The basic color for designating caution and for marking physical hazards that may cause stumbling, tripping, falling, collision, etc.; Yellow and black checks and stripes are usually recommended. (Mobile equipment, covering on guy wires, unguarded platforms, pillars and columns, caution signs, etc.)

**Green:** The basic color for designating safety and first aid equipment. (Safety bulletin boards, first aid kits, stretchers, gas masks, etc.)

**Blue:** The basic color for designating caution - limited to warning against starting or use of equipment under repair. (Barrier flags or signs for elevators, ovens, boilers, etc. under repair.

**Purple:** The basic color for designating radiation hazards. Yellow should be used with purple for tags, labels, and signs. (Rooms and containers storing radioactive material or containers and areas contaminated with radioactivity.)

**Black, white, and gray:** The basic color for designating traffic and housekeeping markings. Solid white, or black, or stripes or checks may be used. (Direction signs, stairways, dead ends, refuse cans, drinking fountains, large stationary equipment, etc.)

**COLOR SELECTION**

Particular reds, yellows, blues, etc. should be chosen to color code equipment in order that partially color blind individuals will be able to make the proper identifications. The specific colors that are least confused by partially color blind observers are designated on page 96. The American Standard Z53.1-1953 also has specified the particular colors to use.

## INSTRUMENT AND CONTROL CONSOLE LIGHTING

Aircraft pilots and other equipment operators must be provided with instrument and control console lighting systems which give minimum interference with outside vision through windshields and other transparent sections. At night it is important that the eyes maintain sensitivity for dim visual objects when outside vision is used. Also, there should be minimum obstruction of vision by windshield reflections and glare sources.

### DARK ADAPTATION

The increase in sensitivity of the eye which results from prolonged periods in the dark is known as dark adaptation. Increased dark adaptation results in increased ability to see dimly illuminated objects. The time course for dark adaptation following exposure to (1) white lights of varying intensities, and (2) lights of various colors are shown below. (See also the table of approximate brightnesses on page 74.)

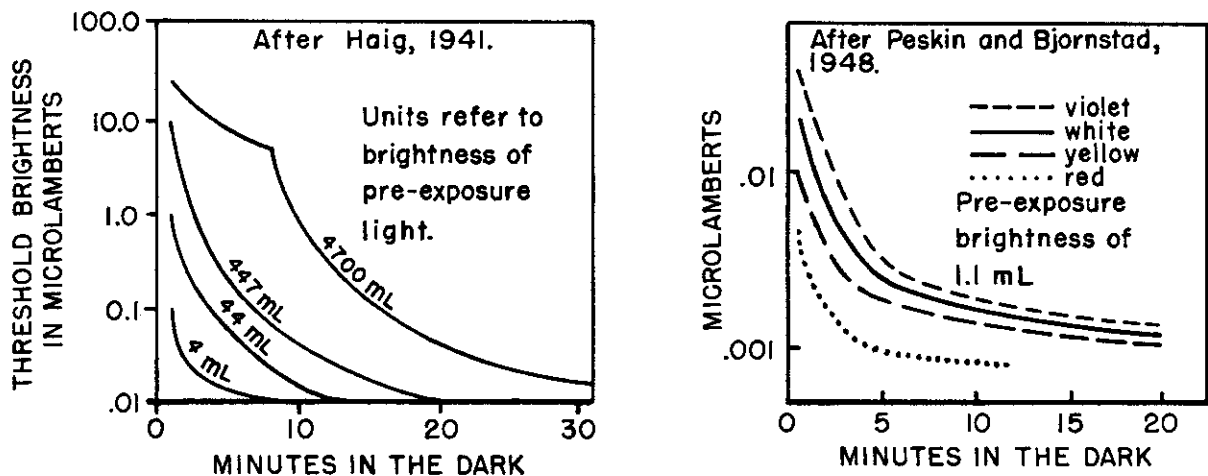

The above graphs reveal two important facts: (1) the time required to adapt to a given level of sensitivity is shorter when the pre-exposure brightness is less, and (2) the time required to adapt to a given level of sensitivity is shorter when the pre-exposure light is composed of longer wavelengths (red). It is also known that loss of sensitivity to dim visual objects is less as a function of (1) shorter durations of the pre-exposure light (see page 34), and (2) smaller areas, in visual angle, of the pre-exposure light.

Because of these characteristics of the human eye, low brightness red light is most satisfactory for instrument lighting in situations where maximum dark adaptation is required for outside vision. Such red light is normally obtained by use of a filter with a cut-off at 6000 A. This cut off point is rather arbitrary. A still higher cut-off would be slightly superior for dark adaptation, but would waste an excessive proportion of the available light energy. Cut-off at a lower wavelength would entail some sacrifice in dark adaptation, but would waste less light.

There are two other advantages in the use of red instrument lighting. These are: (1) At low brightness levels, visual acuity is slightly better for red than for white or other colors of equal brightness, (Brown and Grether, 1952) and (2) Sensitivity to red when compared with other colored lights or white of equal photometric brightness, is reduced

in the periphery of the visual field. Because of this, red light is least likely to be spotted by an enemy observer. Red, like any other highly colored light, has one significant disadvantage. Color discrimination is lost, and brightness relationships for colors are completely changed. This handicaps the use of color coding for range markers on instruments, for color shading on maps, and for similar purposes. It does not handicap the use of colored warning lights. These contain their own light and will be seen in very nearly their true colors.

**REFLECTIONS FROM WINDSHIELDS AND WINDOWS**

Any reflections from a windshield or window which reach the observer's eyes reduce outside vision. This loss in outside visibility results from the direct glare or the covering up or masking of objects by the windshield reflections. The recommendations to control such reflections are as follows:

Use glare shields placed in the light path so as to block any light that would otherwise fall upon the windshield.

Place the lights and lighted surfaces in such positions that reflections will not reach the eye.

Use dark matte surfaces on those areas which might be reflected.

Use a minimum illumination level consistent with adequate seeing of the instruments.

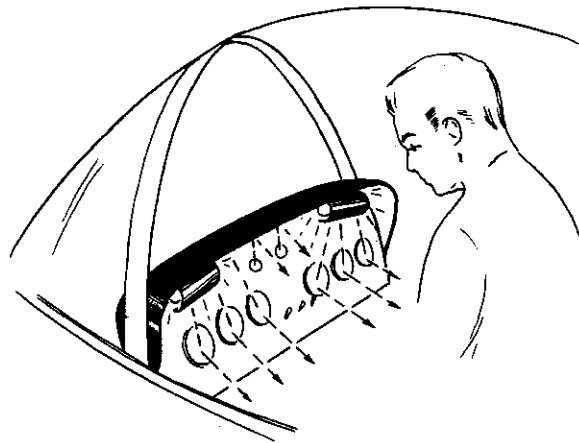

**BRIGHTNESS REQUIREMENTS FOR INSTRUMENT READING**

Both for maintaining dark adaptation and avoiding objectionable reflections it is necessary to use the minimum instrument illumination which will permit adequate instrument reading. The accompanying graph shows the relationship between the brightness of instrument markings and relative efficiency of instrument reading. (Chalmers, Goldstein, and Kappauf, 1950.)

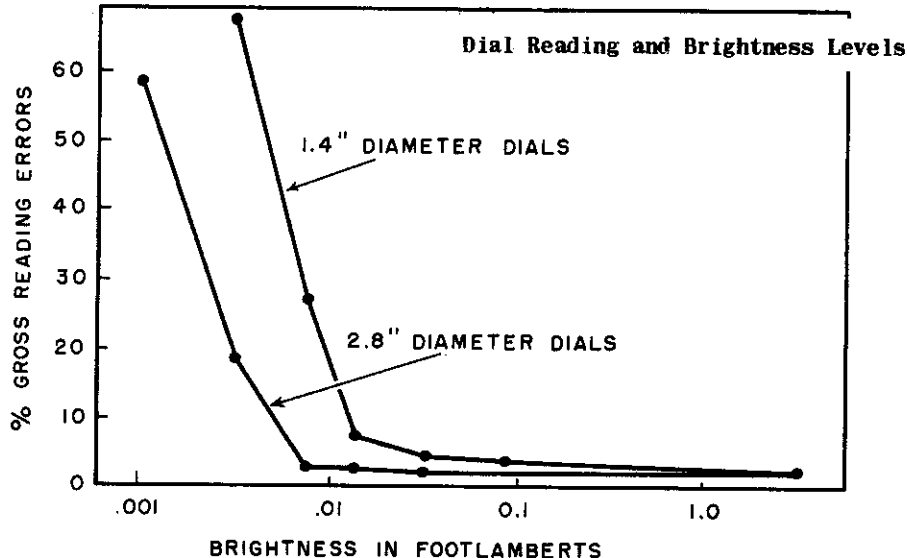



**Recommended Brightness Levels for Night Flying:** From these and other data (Cole, McIntosh, Grether, 1950), it is recommended that the brightness of the instrument markings have a continuously controllable brightness range from .02 to 1.0 foot-lamberts. Refer also to the table on page 86.

#### UNIFORMITY OF LIGHT DISTRIBUTION

The above recommendations assume a uniform distribution of light over all material which must be read. In practice this is impossible to achieve with known lighting techniques. Nevertheless, every possible effort should be made in the design and location of the lighting fixtures to provide for approximate equality of light distribution. Unless this is done, some details will not be legible, while others are too bright. A ratio of 7 to 1 between the brightest and dimmest instruments or portions of instruments is considered the maximum range which is tolerable. All direct or reflected viewing of the light sources must be avoided.

#### SPECIAL LIGHTING CONDITIONS

**Lightning Flashes, Searchlights, Rocket and Gun Flashes:** When the operator is exposed to lightning or other bright flashes of light he may temporarily lose his visual adaptation and be unable to read dimly lit instruments at night. For this contingency an auxilliary white light is recommended. This should provide an illumination of at least 10 footcandles on the instrument panel.

**Simulated Daytime Instrument Flight:** When the amber shield and blue goggles are used for instrument flying the effective brightness of the instruments is greatly reduced. Red instrument light is excluded by the blue goggles. A high intensity white light as recommended for lightning flashes in the paragraph above is recommended.

**High Altitude Daytime Flight:** Because of the less diffuse light at very high altitude, inadequate light may reach the instruments and consoles. This is likely to occur only in aircraft with restricted windshields and windows, and a glare shield over the instrument panel. A high intensity white light as recommended for lightning flashes in the paragraph above is recommended.

**Chart Reading:** For reading charts or other printed material at night, a supplementary light source is required. This is usually an overhead dome light or a lamp on a detachable bracket. Normally, this light should be red to preserve dark adaptation for outside vision. However, current aeronautical charts, because they are printed in color, are limited in readability under red light. White illumination should be used if such charts are used. For all detail to be visible on current charts an illumination of at least 0.1 footcandles on the chart is required. However, reading charts under such low levels of illumination is extremely fatiguing. An illumination of one footcandle or more may be used if the pilot covers one eye while reading the chart. The covered eye remains virtually unaffected, and the total loss in dark adaptation is slight.

#### SELECTION AMONG INSTRUMENT AND CONSOLE LIGHTING SYSTEMS

There are four basic types of instrument lighting systems: Flood, indirect, edge and rear lighting. These are illustrated below. Very often two of these are used in combination.

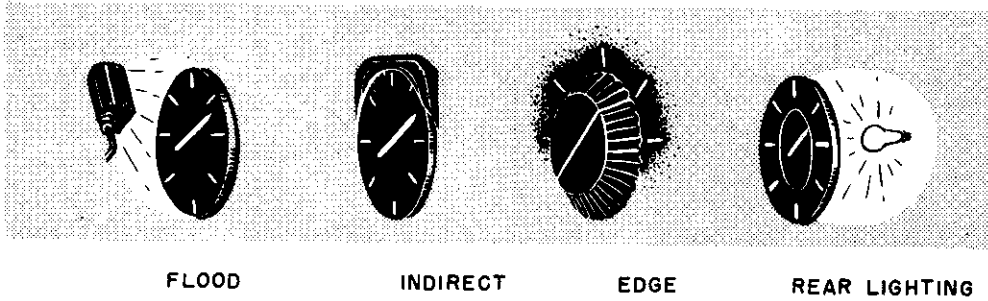

**Flood Lighting:** Light is provided by a fixture separated from the instrument or panel. The light rays have a fairly large angle of incidence. The light source is usually located above the instruments, so that all specularly reflected light will go downward, rather than up into the windshield or the observer's eyes.

**Advantages:**

- Light distribution can be made fairly uniform.
- Decals, knobs, and switches are illuminated, as well as the instruments.
- Illumination of space between instruments aids distance perception in cockpit.
- Number of lamps required is minimal, and they can be accessible for replacement.
- Fixtures do not obscure edges of instrument as in indirect systems.

**Disadvantages:**

- Considerable scatter of light to other areas of the cockpit.
- Often difficult to locate fixtures to light entire panel without obstructing vision.
- Shadows cast by instrument bezel, as angle of incidence is reduced.

**Indirect Lighting:** Light is provided around the rim of the instrument by reflection from a light shield or by transmission through a plastic sheet. The light arrives at a very shallow angle of incidence. Shields may be tailored to individual instruments, or a single shield may cover an entire panel.

**Advantages:**

- Minimum scattered light.
- Permits tailoring of light to individual instruments.
- Integral with instrument or panel. No separate fixtures in cockpit.

**Disadvantages:**

- Difficult to obtain uniform light distribution over single instrument.
- Shadows in depressions. (As on turn and bank, and attitude gyro instruments.)
- No light on decals, knobs or switches between instruments.
- Difficult to avoid occluding edge of instrument for oblique viewing.
- Difficult to eliminate direct or reflected view of light source.
- Pointer may be poorly illuminated.
- Requires tailoring of shields to fit each application.

**Edge Lighting:** Light is conducted through a sheet of transparent plastic, and escapes through markings in the otherwise opaque covering over the plastic. This is not suitable for lighting of conventional instruments, but is excellent for printed instructions, labels, and control knobs on panels and consoles. (For further details see mil spec P-7788.)

**Advantages:**

- Minimum scattered light.
- Integral with panel. No separate fixtures in cockpit.

**Disadvantages:**

- Not suitable for lighting of moving parts, (such as instrument pointers, toggle switches) unless these can be made of plastic and large enough to trap and conduct light.
- Difficult to obtain uniform light distribution.
- Must be tailored to fit each application.

**Rear Lighting:** Light is transmitted from the rear through translucent markings in an otherwise opaque sheet. The effect is very similar to that obtained by edge lighting.

**Advantages:**

- Minimum scattered light.
- Uniform distribution.
- No fixtures in cockpit.

**Disadvantages:**

Difficult to illuminate moving parts (instrument pointers and toggle switches) unless made of plastic and large enough to trap and conduct light.

Lamps inaccessible for replacement.

Requires unobstructed space behind surface to be lighted.

**GENERAL RECOMMENDATIONS**

General recommendations for instrument, cockpit and console lighting are consolidated in the accompanying table.

CONDITION OF USE	RECOMMENDED SYSTEM	BRIGHTNESS OF MARKINGS	BRIGHTNESS ADJUSTMENT
Instrument lighting, dark adaptation critical	Red flood, indirect, or both with operator choice	.02 to 0.1 ft.L	Continuous thru range
Instrument lighting, dark adaptation not critical	Red flood or low color temperature white, indirect or both with operator choice	.02 to 1.0 ft.L	Continuous thru range
Instrument lighting, no dark adaptation required	White flood	1 to 20 ft.L	May be fixed
Control console lighting, dark adaptation required	Red edge lighting, additional red flood lighting desirable.	.02 to 1.0 ft.L	Continuous thru range
Control console lighting, dark adaptation not required	white flood	1 to 20 ft.L	May be fixed
Possible exposure to bright flashes	White flood	10 to 20 ft.L	Fixed
Simulated instrument flying (blue amber)	White flood	10 to 20 ft.L	Fixed
Very high altitude, daylight restricted by cockpit design	White flood	10 to 20 ft.L	Fixed
Chart reading, dark adaptation required	Flood, operator's choice of red or white	0.1 to 1.0 ft.L on white portions of chart	Continuous thru range
Chart reading, dark adaptation not required	White flood	5 ft.L or above	May be fixed

chapter 7

visual detection and identification

This section reviews data on visual resolution as applied to the detection and identification of targets. The meaning of target as used here is any object, pattern, or marking which human beings are expected to detect or identify visually. The visibility of targets in most situations is not under the control of the equipment designer, but data on visibility functions are necessary for estimating human performance in operation of fire control, bombing, and other systems which rely on human vision. Other types of targets such as signalling devices and markings on vehicles, runways, and buildings are usually under the control of the designer. Recommendations for such design applications are included in this section. More data on human visual capacities can be found elsewhere. (Stevens, Ed., 1951; Tufts Handbook, 1949; Chapanis, Garner, and Morgan, 1949.)

VISUAL ACUITY

Visual acuity is an important limiting factor in all human detection and recognition of targets or other visually presented information. Acuity, like other visual capacities, is measured and defined in terms of thresholds. A visual threshold is a value determined statistically at which there is a 50% probability of the target being seen. In most practical situations a higher probability of seeing, such as 95 or 100%, is required. The general relation between threshold size and probability of detection is an ogive function of the general form shown in the graph below.

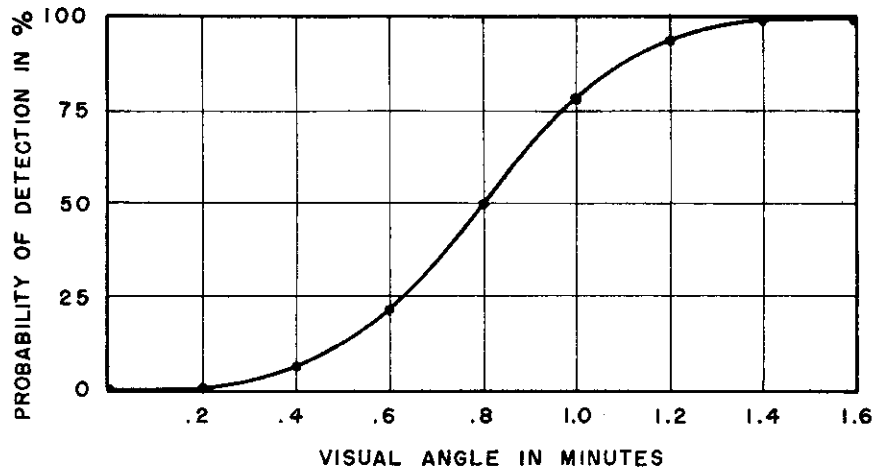

This curve may be used as a rough guide for estimating visual angles which will yield various probabilities of detection. It can be seen that doubling the visual angle for 50% probability of detection should give almost 100% detection if the location of the object is known. The threshold data that follow are based on the 50% probability of detection. As a rough rule of thumb, these visual angle values should be doubled to give near 100% threshold values.

There are several ways in which visual acuity has been defined and measured, each of which has significance for detection and recognition of detail. Various kinds of visual acuity measures are enumerated below. See page 72 for the definition of visual acuity.

**GAP RESOLUTION (MINIMUM SEPARABLE ACUITY)**

Gap resolution has been measured with a variety of visual acuity targets. Three typical types of targets are illustrated below.



Alternating black and white lines  
equally spaced

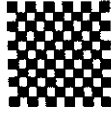

Black and white checkerboard



Landolt ring  
(Gap equal to width of ring)

**Visual acuity and illumination:** Visual acuity measured with such targets varies with the brightness of the targets and the background, and hence the illumination. The minimum visual angle that can be resolved as a function of brightness is illustrated below for a Landolt ring type target.

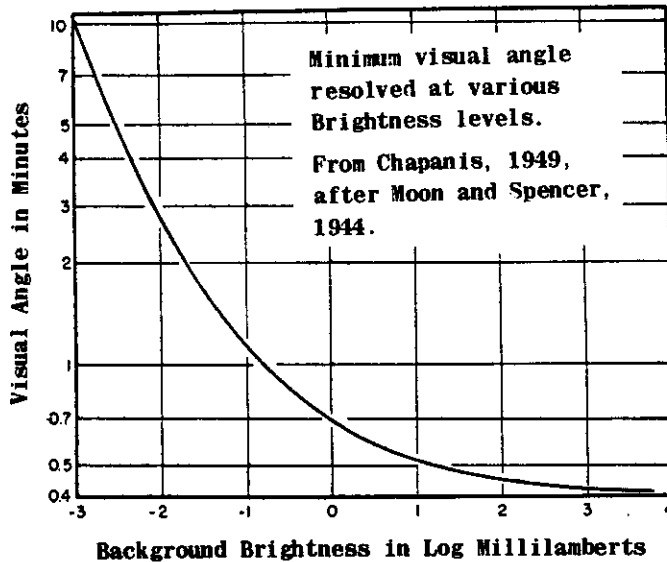

It is evident from this curve that smaller visual angles are resolved, i.e., visual acuity improves with increasing brightness until a level is reached beyond that normally found under artificial illumination. As a rough rule of thumb, the eye can resolve one minute of visual angle at normal working levels of illumination. This is limited, however, to persons with normal vision and to the viewing of detail of fairly high contrast (above 50%).

**Visual acuity and contrast:** As contrast is reduced, e.g., from black on white to gray on white, the minimum resolvable visual angle becomes greater. Contrast is defined by the following equation:

$$\text{Contrast (\%)} = \frac{B_1 - B_2}{B_1} \times 100 = \frac{\text{Brightness difference}}{\text{Background brightness}} \times 100.$$

The effect contrast has on minimum separable acuity is shown below for a dark Landolt ring at three background brightnesses.

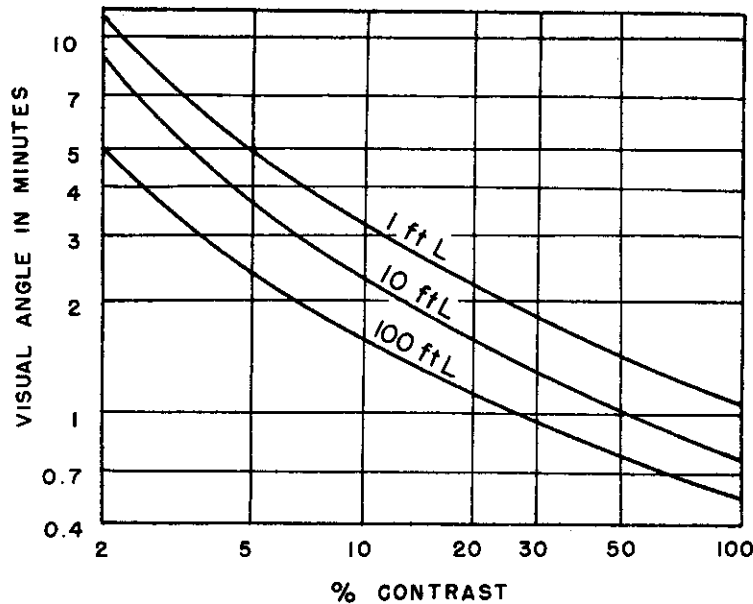

Minimum visual angles for various contrast ratios.

After Cobb and Moss, 1928.

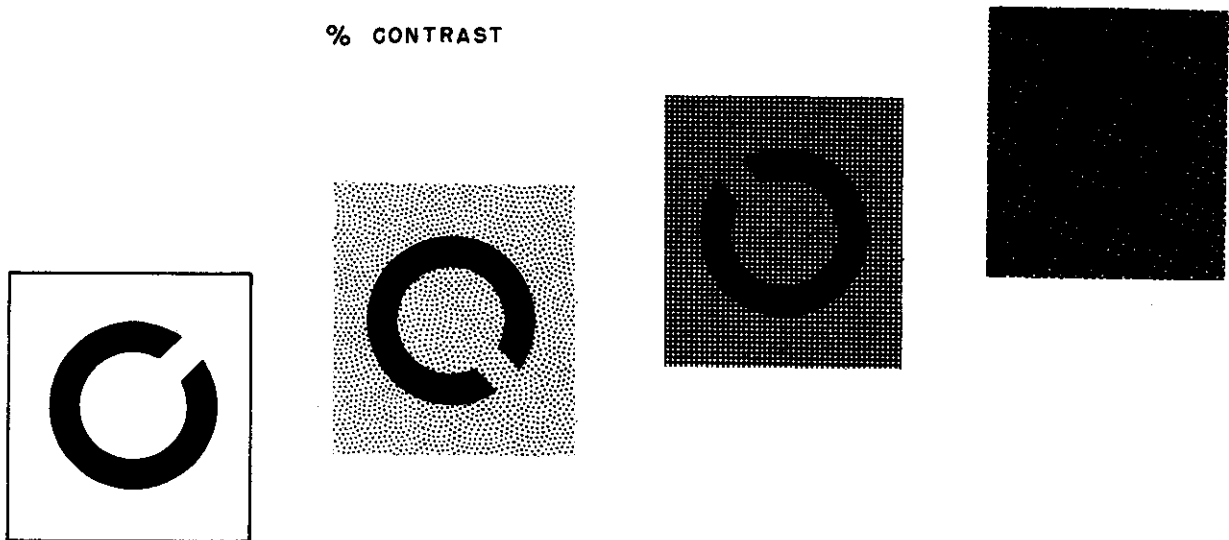

**SPOT DETECTION (MINIMUM PERCEPTIBLE ACUITY)**

The most applicable type of visual acuity data which pertains to target detection is data concerning minimum perceptible acuity, i.e., where a spot is seen against a uniform background. The spot may be lighter or darker than the background. From the contrast formula on page 72 it is evident that contrast can range from 0 to 100% for targets darker than the background and from 0 to infinity for targets brighter than the background. Variation in minimum perceptible acuity with both background brightness and contrast is shown below. The contrast curves from 0 to 100% apply to signals both brighter and darker than the background. The curves with contrast above 100% apply only to signals brighter than the background. The thresholds are for 99% probability of detection.

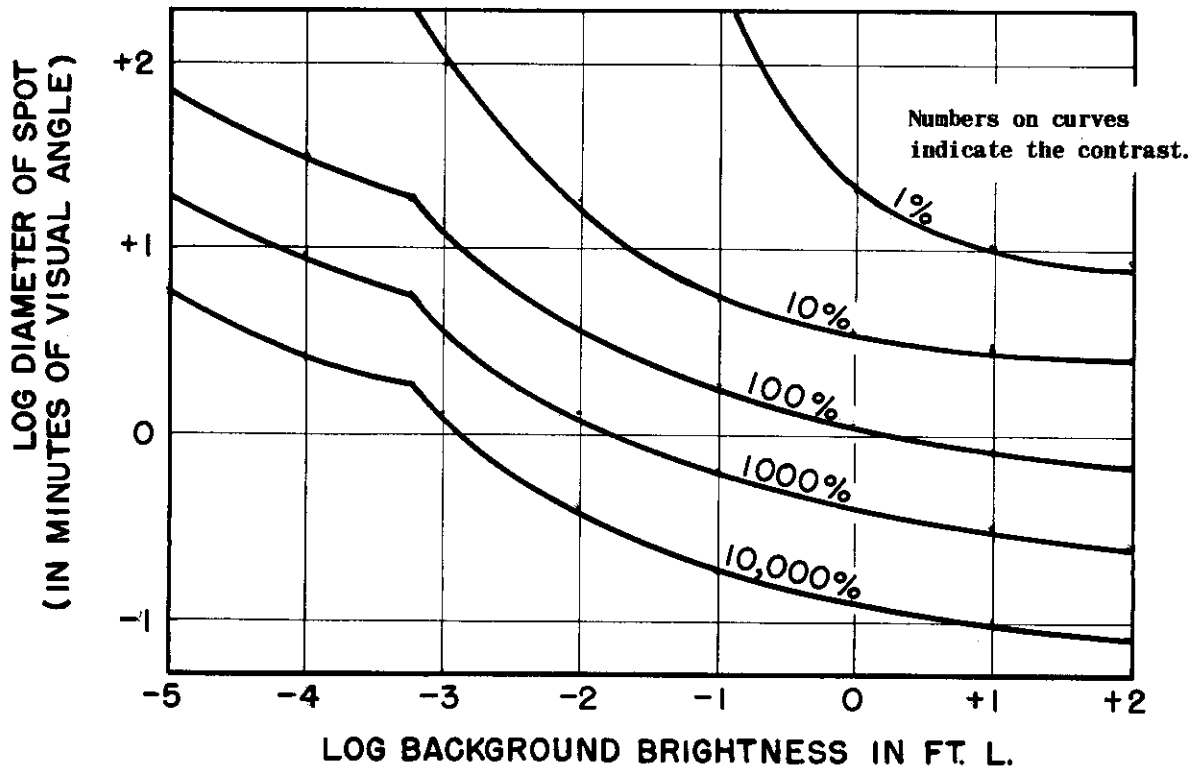

There is no known lower limit of visual angle for bright targets on a dark background. The star, Mira, for example, is clearly visible and subtends a visual angle of only .056 seconds of arc. The visual angle subtended by visible lines and squares against bright backgrounds may be much smaller than those in the above graph if the background brightness is greater and if there is high contrast. A wire one degree long against a bright sky (2000mL) is visible 75% of the time if it subtends a visual angle of only 0.43 seconds in width. A dark square against a bright sky is visible 75% of the time if it subtends a visual angle of only 14 seconds. (Hecht, et al., 1947.)

**DETECTION OF MISALIGNMENT (VERNIER ACUITY)**

Detection of misalignment is normally measured by the use of two lines, one of which is displaced laterally as shown on the next page. The threshold visual angle is the minimum lateral displacement which can be detected. This type of visual acuity is involved in reading instruments and in some types of sighting. Such acuity is relatively unaffected by the thickness of the lines used. Vernier acuity is very good, as is seen in the following graph.



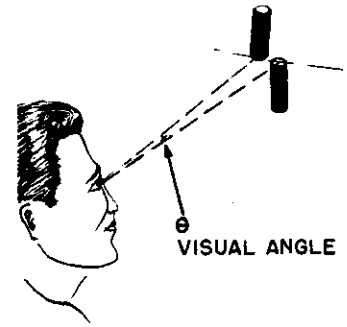
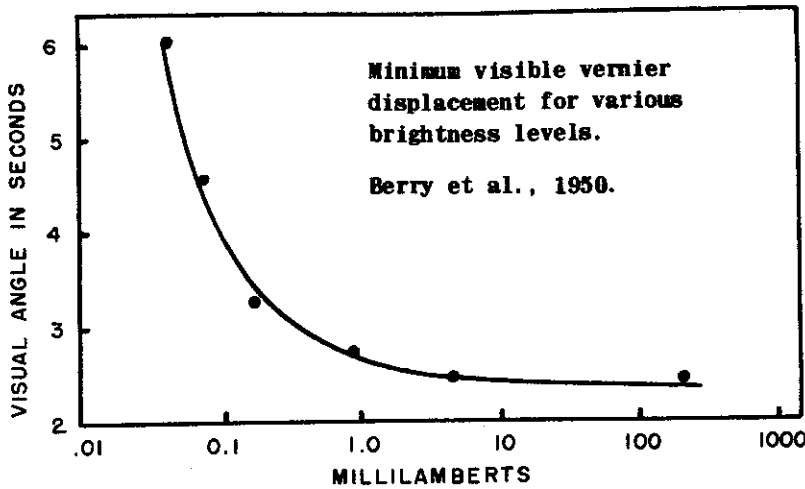

**STEREOSCOPIC ACUITY**

Because of the lateral separation of the two eyes, each receives a slightly different view of nearby objects. At the point of convergence, objects are seen singly. Objects at other distances are seen as double images. The disparity in the images reaching the two eyes provides stereoscopic perception of depth, and aids in judgment of relative distance. The stereoscopic acuity threshold is defined as the difference between the parallactic angles of two objects when one is judged just noticeably nearer or farther than the other object (see diagram). The graph below shows stereoscopic depth perception acuity as a function of the brightness of the viewed objects. (Berry, et al, 1950.)

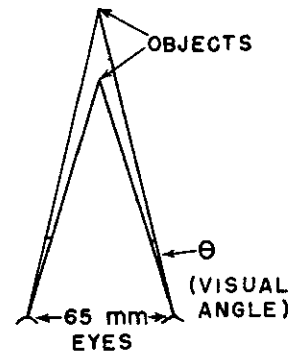
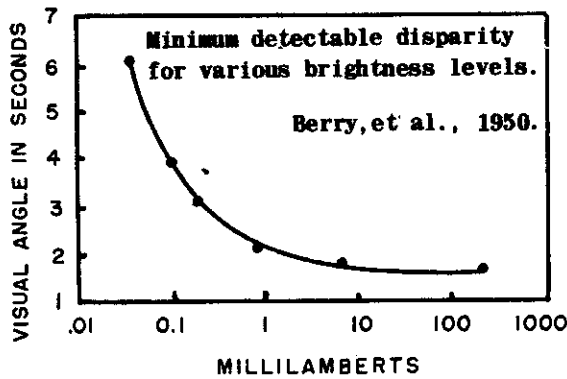

With greater distances between the observer and objects, the advantage of binocular vision (stereoscopic cues) over monocular vision decreases. The curve below shows the ratios of binocular to monocular depth perception thresholds as a function of the distance. (Hirsch and Weymouth, 1947.)

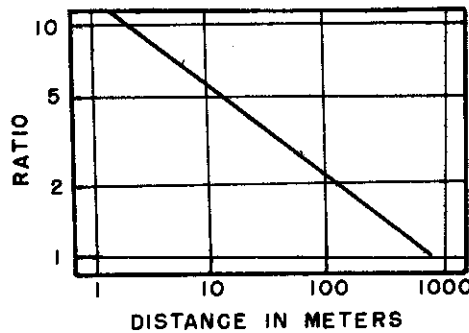

It is evident from this graph that binocular (stereoscopic) cues aid considerably in depth perception at near ranges (ten times lower thresholds), but at greater ranges monocular depth perception is equally as good. In general it may be stated that stereoscopic depth perception is relatively unimportant beyond distances of 500 yards.

### REDUCTION OF VISUAL ACUITY BY GLARE

Visual acuity is at a maximum when the eye is adapted to the brightness level of the target and immediate surround. A condition of glare occurs when the target and immediate surround are at a lower brightness than the greater surrounding area or background. An example of this is where the target is in shade, but most of the surrounding area is illuminated by bright sunlight. The general level of adaptation is raised by the sunlight, and any objects in the shade are poorly seen. Markings on the underside of aircraft usually are poorly seen, because they are in shadow and at much lower brightness than the sky background. Acuity is similarly reduced if the general background is considerably darker than the target, but this effect is very slight. The curve below shows the effect of surround brightness, for backgrounds both darker and brighter than the target and the immediate surround. The effect is much more serious under the condition of glare, where the surround is brighter. The area producing glare need not surround the target, or even adjoin it, although the effect will diminish as the glare source is displaced from the target. See also pages 76 and following.

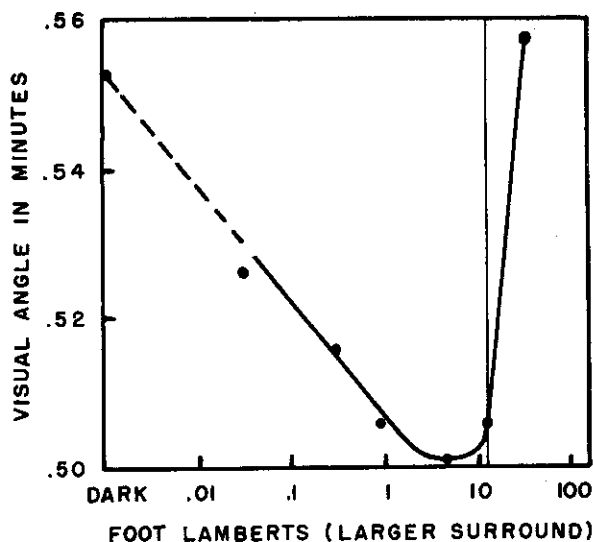

Minimum visible visual angle for various levels of surround brightness.

The brightness of the task area and immediate surround is indicated by the vertical line. (After Lythgoe, 1932.)

It is clear from the above that to be maximally visible, targets, or markings on a target, should not be in a shadow or near an area of much higher brightness.

**VISUAL ACUITY IN RELATION TO SCANNING FOR TARGETS**

In all of the foregoing discussion, it has been assumed that the observer knows the location of the target well enough to fixate it in the center of his visual field. In searching for targets this is rarely the case. Below we consider visual acuity for targets as a function of overall brightness levels and the retinal position of the target.

**Visual acuity and retinal location:**

Fine detail vision is possible only at the center of the retina at the back of the eye in an area called the fovea. The variation of acuity, as measured by the Landolt Ring, with distance from the fovea at various brightnesses is illustrated at the right. The curves reveal: (1) at usual levels of illumination (brightnesses of about .01 mL) and above) acuity is greatest in the fovea and falls off rapidly in the periphery, (2) at low brightness levels (below .01 mL) maximum visual acuity, though very low, appears to be from 4° to 8° peripherally, (3) at very low illumination levels (.00004 mL) visual acuity is constant and poor throughout the periphery. See the table of approximate brightnesses on page 74.

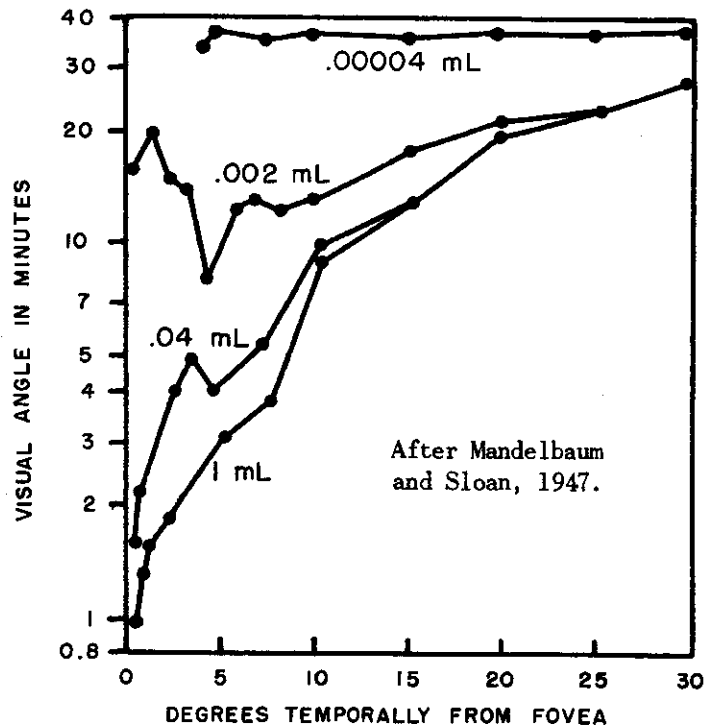

The graph indicates that at foveal brightness levels (above .01 mL) targets will be seen when fixated by the fovea. To be seen peripherally at the same brightnesses the target would have to be 10 to 20 times larger than the size required for detection in the fovea. If the area to be scanned is restricted, such as along the horizon, the probability of foveal fixation, and, therefore, detection, is high. If the area to be searched is large, such as the sky or a sector of the sky, the probability of foveal fixation is reduced, and rather large targets can be missed. Systematic patterns of visual scanning to insure adequate coverage of the area should be used to increase the probability of detection.

At very low levels of brightness the target cannot be seen centrally, i.e., foveal viewing. At low brightness levels (below .01 mL) the observer must look 4° to 8° off center to get maximum acuity.

Visibility and retinal location: The curve below shows the threshold of seeing a white light subtending a visual angle of  $1^\circ$  at various retinal positions.

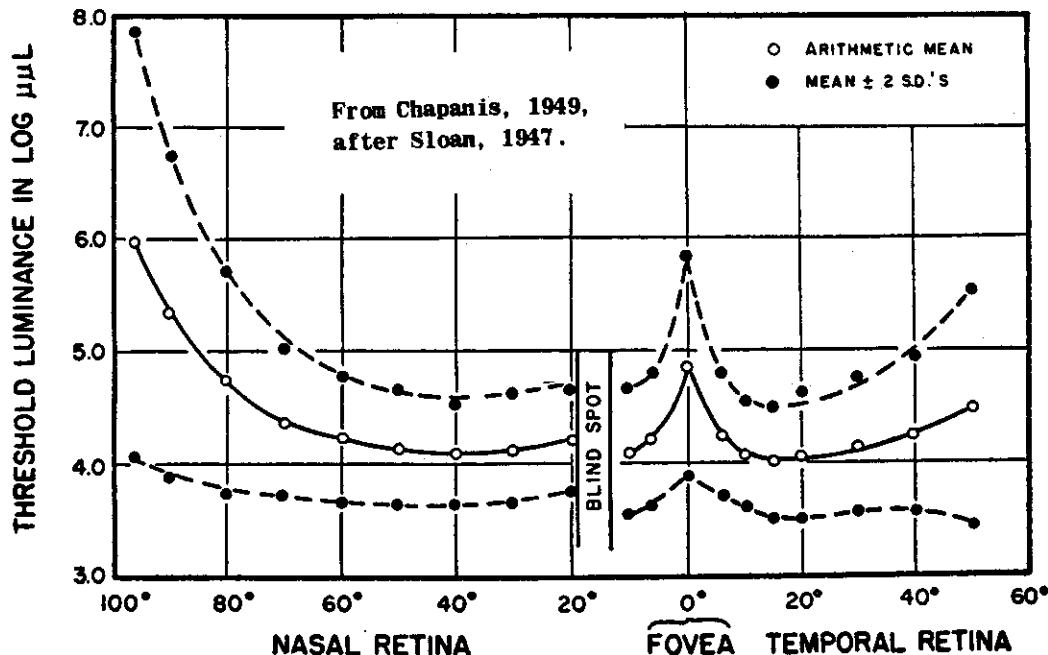

The solid line is the average curve for 101 subjects. Ninety-five percent of the subjects fell within the area inclosed by the dotted lines. The curve indicates that the most sensitive portion of the dark adapted retina is from  $10^\circ$  to  $30^\circ$  from the fovea. The previous curve for the Landolt ring indicated maximum acuity from  $4^\circ$  to  $8^\circ$  peripherally. The value  $4^\circ$  to  $8^\circ$  is the peripheral area that is most capable of resolving target detail whereas the  $10^\circ$  to  $30^\circ$  area is for detection of dim targets. In both cases night observers should be trained to use off-center fixation.

**VISUAL ACUITY AS A FUNCTION OF THE COLOR OF ILLUMINANT**

The color of the illuminant can be controlled either at the light source or by filters before the observers eyes. Both methods give the same effect. Two theoretical reasons have been advanced why visual acuity should be improved by the use of colored illuminants by comparison with white illumination: (1) chromatic aberration in the eye, and (2) greater optical scattering of the shorter wavelengths. Because of these two effects maximum acuity should be possible with monochromatic wavelengths from the long wavelength end of the spectrum. Experimental findings concerning visual acuity and color of the illuminant have been somewhat contradictory. (Ferree and Rand, 1931, and Baker, 1949.) The one consistent finding is that illumination from the short end of the spectrum (blue) is inferior to light of other monochromatic wavelengths or to white light.

Normally the use of colored illuminants, or viewing through colored filters, is not recommended when visual acuity should be maximized. The loss in brightness caused by a colored filter may decrease acuity. Under many conditions, where illumination is marginal, the light loss caused by the colored filter is definitely undesirable.

A further complication in the use of colored illuminants is the loss or reduction of color contrast and the distortion of the normal brightness relations. Objects of the same color as the illuminant will be increased, relatively, in brightness and may become invisible against a light background. Objects of complementary color will be darkened and may be invisible against a dark background. This effect can be used to advantage in some highly specific applications. In most cases this distortion of normal brightness and color relationships is a serious handicap, and greatly reduces the total information which can be resolved by the eye. In effect, the use of colored illuminants renders persons with normal vision color blind.

**DETECTION AND RECOGNITION OF COLORED TARGETS**

All of the foregoing apply to targets and backgrounds which are achromatic, that is, white, black, or some intermediate shades of gray. With high brightness contrast between target and background the addition of color contrast (target and background of different colors) will not appreciably improve acuity. At moderate and low levels of brightness contrast the addition of color contrast can improve acuity. The extent to which acuity can be improved depends upon the particular colors used. The highest color contrast possible produces visual acuity which is equivalent to the acuity produced by a brightness contrast of 35%. (Eastman Kodak, 1944.) In other words, acuity is increased much more by increasing brightness contrast than by increasing color contrast.

**Target detection by surface color:** There is a frequent need to see and to identify objects on the basis of the color of the objects' surfaces. One major consideration is the ability with which the object may be seen against its background. Detectability is increased when color and brightness contrast between the object and the background is increased. Therefore such objects as life rafts, parachutes, survival tents, highway markers, and other such objects should have carefully chosen colors and brightnesses. Generally speaking, orange (International Orange) is seen best at great distances. Detectability can be further increased by addition of fluorescence which increases brightness. Fluorescent orange, neon red, and red are recommended for survival equipment that must be seen at great distances. However, if the background is predominantly orange, red, or brown, objects should be green for maximum detectability. Against blue-green foliage or water, orange, red, or neon red of high brightness is best.

**Surface color coding for normal and color blind observers:** Another use of color is in coding, that is, the correct identification of an object by its color. For example, wires, resistors, pipe lines, gas cylinders, poker chips, and many other objects are color coded. However, a large proportion (6%) of our healthy male population possesses a significantly reduced ability to distinguish color differences. (Only .003% of the population are completely color blind, that is, they see only various shades of gray.) Since color coding is frequently used with unselected populations, at least with respect to color vision, the selection of the particular colors for coding becomes an important consideration. The four colors listed below are considered ideal for coding because color deficient individuals can also easily recognize them. The numbers refer to the Federal Specification TT-C-595, 'Colors for Ready Mixed Paints,' with the exception of blue (10B 7/6) which is a Munsell notation. (See reference.)

- Black.....1770
- White.....1755
- Yellow.....1310
- Blue.....10B 7/6

However, more than four colors will frequently be required to code objects. The nine colors listed below were selected to be the least confusing for individuals with normal and color defective vision. See page 80 for specific color coding applications.

- |                 |                  |                |
|-----------------|------------------|----------------|
| Red.....1110    | Blue.....10B 7/6 | White.....1755 |
| Orange.....1210 | Purple.....2715  | Black.....1770 |
| Yellow.....1310 | Gray.....1625    | Buff.....1745  |

**Colored lights:** Color coded signal lights are used on display panels, maintenance equipment, and in navigational aids to air, marine, and surface vehicles. The number of colored lights that can be absolutely identified by normal observers is about eleven. This is true only if the colors are chosen as indicated on page 48.

However, only three colors are recommended for signals if color defective observers are expected to respond correctly to these signals. These three colors are aviation red, aviation green, and aviation blue as defined by the Army-Navy Aeronautical Specification AN-C-56, 'Colors, Aeronautical Lights and Lighting Equipment.' Aviation blue is distinguished from red and green only at moderate distances. (It must be noted that the specific requirements for these colors must be adhered to if the code is to be used by color deficient personnel because there are many reds, greens, and blues that will be confused. Also, no attempt should be made to include white or yellow in conjunction with the three recommended colors because the color deficient individuals may confuse red with yellow and green with white.)

**Color recognition thresholds:** Signal lights used in air and marine navigation are viewed at great distances. The visual angles (see page 72) subtended by such sources are small and can be considered as point sources of light. The recognition of a signal light color depends upon (1) the intensity of the light source, (2) the brightness of the background, and (3) the particular colors observed. The graph below shows the intensity of a point source signal light for various colors viewed against various neutral background brightnesses that will be correctly identified 90% of the time.

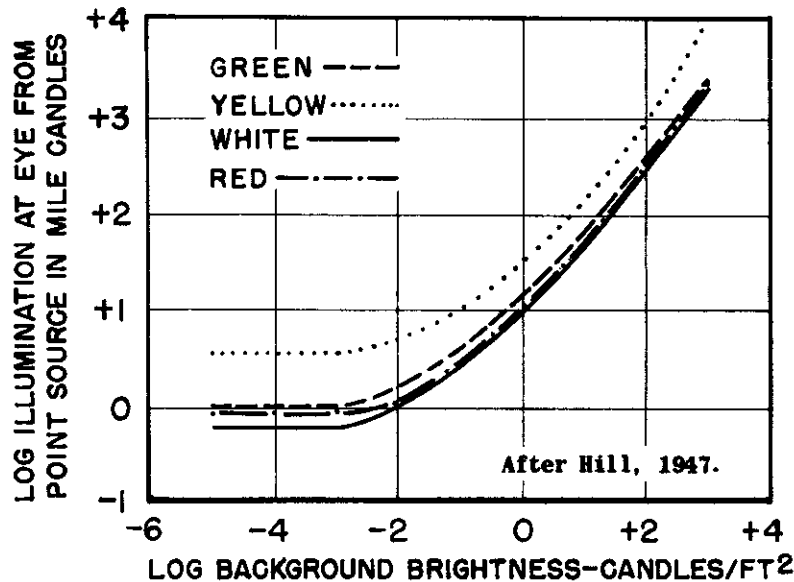

The findings indicate that yellow signal lights require the greatest intensity. The study also revealed that red and green signal lights were rarely interchanged, that is, red was rarely called green and green was rarely called red. On the other hand the yellow light was frequently confused with red.

These data apply to situations where the observer knows the location of the signal. In actual situations the observer usually knows only the general direction of a sought for signal light. For such situations the threshold recognition values should be doubled. The signals can be seen at lower intensities than shown on the graph, but the colors may not be identified correctly.

### TARGET DETECTION AGAINST NON-UNIFORM BACKGROUNDS

The difficulty of detection is greatly increased when the target appears against a mottled or patterned background. This is particularly true if there are objects in the background which resemble the target in size, color, and brightness. Under such circumstances a target will have to be considerably larger than would be predicted from visual acuity data. The threshold visual angle will be highly variable for different backgrounds. The following rules will aid in making targets most visible against non-uniform backgrounds.

Choose a color which contrasts most with all colors in the background.

Choose a brightness which differs maximally from the background, white or bright colors against predominantly dark backgrounds, and vice versa.

Use a fluorescent color, particularly against dark backgrounds.

Use as large an area of solid color as possible. Do not use stripes or checkerboards. At great distances such patterning is not visible and reduces the contrast of the target against the background.

If the background color cannot be predicted the target may be painted in two contrasting colors, dividing the target so as to give the two largest possible areas of solid color. One or the other of the two colors will contrast with any background. Good color pairs for such target markings are:

White - Red  
Bright Yellow - Black  
Bright Yellow - Blue  
Bright Green - Red

### PATTERN RECOGNITION AND IDENTIFICATION

Normally, a target can be detected at greater distances (smaller visual angles) than it can be recognized or identified. Identification normally requires the seeing of details not visible at initial detection. Just how much nearer or larger a target must be for identification cannot be stated in general terms, although it can be measured for specific targets and conditions. Several rules can be stated which aid in predicting threshold size for identification. These can also be used as a guide in designing patterns for ease of identification at maximum distance.

Identifying details must exceed the threshold for visual acuity. The applicable visual acuity measure depends upon the nature of the detail. A gap in silhouette must exceed the minimum separable acuity threshold. Superimposed pattern must exceed the minimum visible acuity threshold.

Corners become rounded at small visual angles and lose their identifying value. Thus a square, or triangle, may appear round at maximum viewing distance.



Large or gross variations in patterns will be seen at greater distances than numerous but smaller variations.

#### MAGNIFICATION AIDS TO VISION

Target detection and identification may be improved by the use of telescopes and binoculars or similar means of optical magnification. The gain, however, is never equal to the magnification ratio, because of several degrading factors.

Brightness of the target is reduced.

Contrast ratio of the target to background may be reduced.

The sharpness of the image is slightly reduced, depending upon the quality of the optical elements.

Movement of the target is amplified.

Any movement or vibration of the optics causes unsteadiness of the image in the eye.

The field of view is restricted.

All of these degrading factors increase with the magnification ratio. Because of this, high magnification ratios are unsatisfactory for most applications. If the location of the target is known, or if the area to be scanned is limited, a moderate to high magnification ratio will be helpful. If the area to be scanned is large, if the rates of relative movement are high, or if the time for detection is limited, magnification is more likely to be a hindrance than an aid. In most situations initial scanning is best done with unaided vision. After targets are detected or suspicious areas located, magnification can be used to verify and identify the target. General recommendations for magnification ratios of several optical devices are presented below.

For aircraft bombing telescopes provide one power for use in initial target location, 2-3 power for target study and bomb drop.

For aircraft fire control telescopes use 1-1.5 power. Movement rates and restrictions in field of view make higher powers unsuitable for general use.

For binoculars in aircraft or moving ground vehicles, hand held or mounted binoculars of 3-4 power may be of assistance after a potential target has been located by direct vision. Higher powers are not recommended because of restricted field and vehicle motion.

For hand-held binoculars on a stable base (ground or sea vessel), 6-8 power is generally recommended. Higher powers can be used successfully for binoculars or telescopes supported on a mount or stabilized in some other manner.

**VISUAL ESTIMATION OF SIZE, RANGE, VELOCITY, AND ACCELERATION**

The human eye has remarkable capacities for resolution of detail and for detection of small differences in various visual parameters. Judgment of values in an absolute sense, however, is comparatively poor. This shows up in the estimation of size, distance, velocity, and acceleration in absolute or numerical terms. Moreover, all of these variables are inter-related. That is, unless distance is known, size and velocity estimation are very inaccurate and unreliable. Estimates of changes in velocity (acceleration) become even more difficult and unreliable.

**Estimation of Size:** It is obvious that for an unfamiliar target, the size cannot be estimated independent of information concerning range or distance to the target. Any factors which distort range estimation will have a direct effect on judgement of size. If range is underestimated, the size will likewise be underestimated. In cases where there are no intervening objects to give distance cues, such as viewing across smooth water, the distance is underestimated, and, therefore, the size of the viewed object is underestimated.

**Estimation of Range or Distance:** The visual estimation of range is very much dependent upon the presence of intervening objects. If the distance (or size) of these other objects is known, the distance of an unfamiliar target can be estimated with fair accuracy. If, however, there are no intervening objects, as in viewing against the sky or across a large body of water (particularly smooth water) distance judgment is very inaccurate, and range is usually underestimated. Against a clear sky, except at very close range, distance estimation is impossible unless the observer has some information about the size of the target. For a more complete treatment of factors influencing distance judgment see Stevens, 1951, Gilinsky, 1951.

**Estimation of Velocity:** Visual estimation of velocity is extremely inaccurate, in the absence of known data about the probable velocity of familiar targets. Like size, estimation of velocity is directly related to the estimation of range. If range is underestimated, velocity is also. Probably because of overestimation of range, small objects (insects, birds) appear to move faster than large objects (airplanes).

**Estimation of Acceleration:** Rather little is known about human visual ability to estimate velocity change (acceleration) except that it is extremely inaccurate and unreliable.

It is evident from the foregoing that human beings are relatively ineffective in judging elevation and lead in visual fire direction at moving targets. Only in rather specific situations, such as skeet or trap shooting, can a human being become effective in elevation and lead estimation and then only after considerable training.

APPENDIX

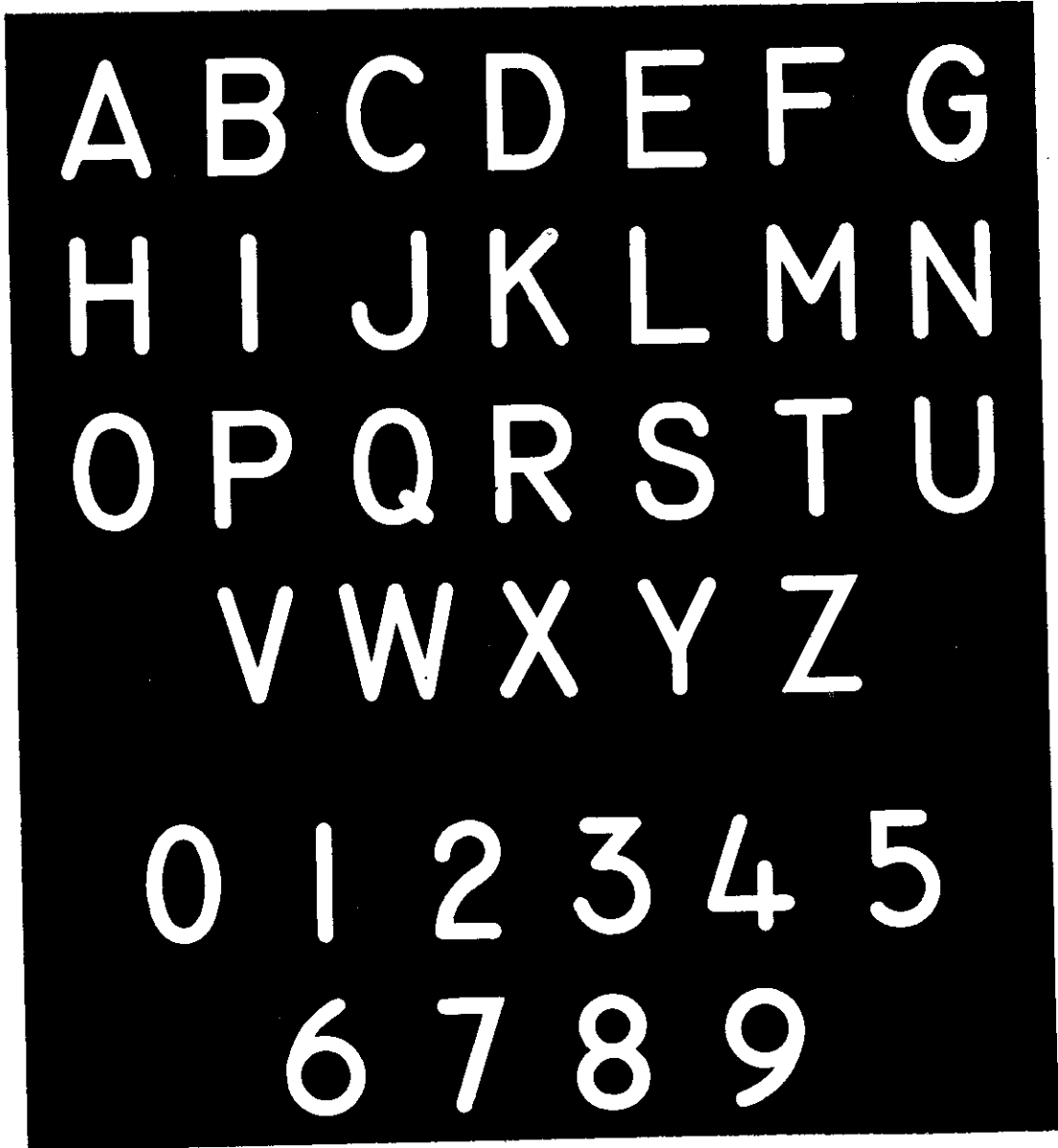

AND 10400 recommended numerals and letters. See page 24.

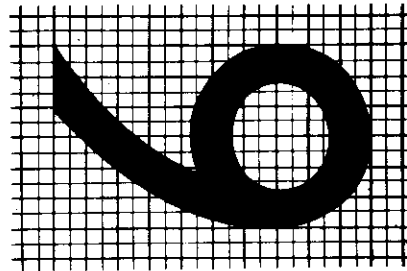
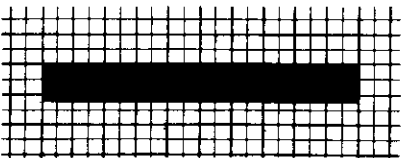
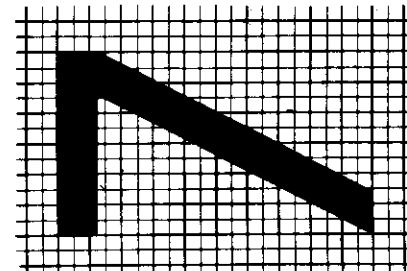
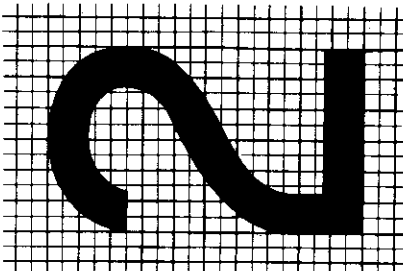
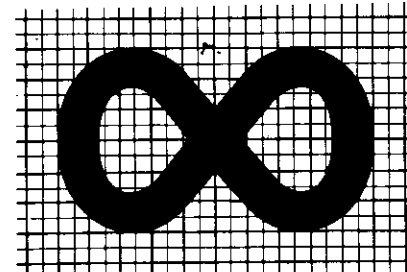
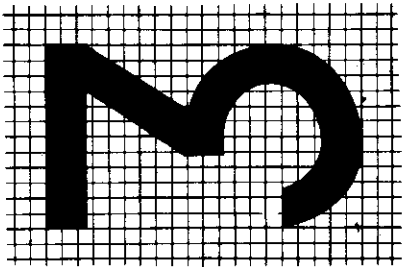
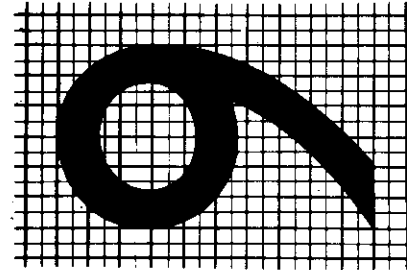
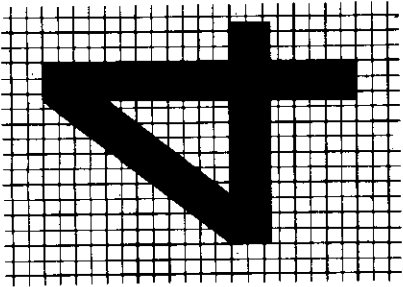
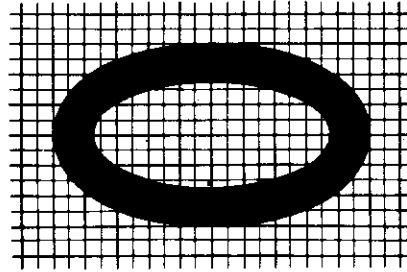
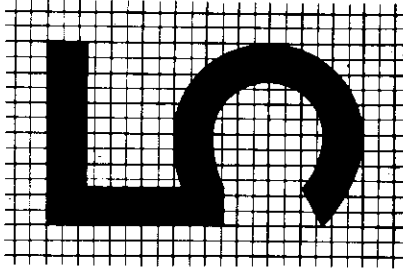

NAMEL recommended numerals. See page 24.

## SUBJECT INDEX

- Aircraft reference indicators, 7  
Aircraft attitude, 7  
Altimeters, 6  
Angular orientation coding, 52  
Area coding, 50  
A-scan, 27  
Attitude indicators, 7  
Bearing counter, 43  
Bearing dials, 43  
Bearing estimates, 43  
Bearing indication, 43-44  
Brightness  
    coding, 53  
    contrast, 30, 33, 72, 89-90  
    conversion table, 73  
    dark adaptation, 32-34, 81-82  
    definition, 70  
    instrument markings, 24, 82, 86  
    surround, 78  
    table of, 74  
    visibility, 30, 33-34, 90  
    visual acuity, 30, 87-91  
    warning lights, 25  
B-scan, 28  
Candle, 69  
Cathode-ray Tubes, 27-55  
    adaptation level and visibility, 31  
    angular orientation coding  
    area coding, 50  
    bearing indication methods, 43-44  
    brightness coding, 53  
    check list, design criteria, 29  
    code compatibility, 47  
    color coding, 48  
    common types of, 27  
    definition of terms, 27  
    design factors in visibility, 31  
    flash rate coding, 53  
    line length coding, 51  
    polaroid lighting, 38-39  
    range indication methods, 40-43  
    resolution, 29  
    selective spectrum lighting, 38-39  
    shape coding, 48-50  
    signal size and brightness, 30  
    signal strength and visibility, 33  
    scope size, 36  
    stereo-depth coding, 54  
    subjective scaling, 47  
    three coordinate displays, 45  
    visibility, 30  
    visibility and signal duration, 35  
    visibility and dark adaptation, 31  
    visibility and viewing angle, 35  
    visibility and viewing distance, 35  
    visual number coding, 51  
    workplace lighting, 37  
Caution indicators, 26  
Chart brightness requirements, 83  
Check lists  
    aircraft, 57  
    design criteria, 2, 29, 59  
Check reading, 1, 4  
Code compatibility, 47  
Coding, 46-55  
    angular orientation, 52  
    area coding, 50  
    brightness, 53  
    color, 21, 48, 79-80, 96-97  
    flash rate, 53  
    line length, 51  
    shape, 21, 48-50  
    stereo-depth, 54  
    table of, 55  
    visual number, 51  
Color  
    coding, 21, 48, 79-80, 96-97  
    contrast, 98  
    lighting, 38-39  
    visual acuity, 95  
Combined instruments, 66-68  
Contrast, (see brightness and color)  
Controls, location of, 2, 65  
    direction of movement, 10-13  
Counters, 3-6, 13, 43  
Cross pointer indicator, 8  
C-scan, 28  
Dark adaptation, 32-34, 81-82  
Decals, 57  
Dials, see mechanical indicators  
Diffuse lighting, 76  
Diffuse reflectance, 70  
Direct lighting, 76  
Earth reference indicators, 7  
Edge lighting, 85  
Emergency instructions, 57

- Filters, 38-39, 71
- Flag warnings; 25
- Flash rate coding, 53
- Flood lighting,
  - general methods, 76
  - of instruments, 84-85
- Fly to indicators, 7
- Fly from indicators, 8
- Footcandle, 69, 73, 75
- Footlambert, 70, 73
- F-scan, 28
- Gap resolution, 87
- Graduation marks, 14-19
  - definition of terms, 14
  - dimensions, 18-19
  - numbering, 14
  - spacing, 18-19
- Glare, 76-78, 92
- Graphs, 58
- Heading indicators, 8, 17, 66
- Illumination, 69-86
- Indicators, see mechanical indicators or cathode-ray tubes
- Interpolation, 19, 41
- Indirect lighting,
  - general, 76
  - of instruments, 84-85
- Instruments, see also mechanical indicators
  - brightness, 82, 86
  - identification, 23
  - labels, 23
  - panel layout, 59-68
- Labels, 58
- Lambert, 70, 73
- Letters and numerals, 24, 56-58
- Lighting, 69-86
  - brightness contrast, 72
  - color, 38-39, 79-80
  - conversion table, 73
  - dark adaptation, 81-83
  - definition of terms, 69-70
  - glare, 76-78
  - instruments, 81-86
  - light distribution, 76
  - special conditions, 12
  - surround brightness 78
  - table of brightnesses, 74
  - visual acuity, 72
- Lighting and cathode-ray tubes, 37-39
  - and light adaptation, 32
- Line length coding, 51
- Long scale indication, 6
- Magnification aids to vision, 99
- Mechanical indicators, 1-24
  - aircraft reference (fly from), 7
  - basic types, 5
  - check list of design criteria, 2
  - earth reference (fly to), 7
  - general consideration, 1-2
  - interpolation, 19
  - instrument identification, 23
  - instrument zone markings, 21
  - log scale indication
  - numerals and letters, 24
  - pointer design, 22
  - scale design, 14-20
  - scale dimensions, 18
  - scale numbering, 14
  - selection of pictorial indicators, 7-9
  - selection of symbolic indicators, 4-6,
  - table of recommended scales, 16
  - table of recommended indicators according to use, 4
- Millilamberts, 70, 73-74
- Moving pointer indicators, 3-6, 10, 11
- Moving scale indicators, 3-6, 12-13
- Multi-revolution scales, 6
- Non-linear scales, 17
- Numerals and letters, 24, 56-58
- Navigational displays, 9
- Numerical progression for scales, 14, 40
- On-off indicators, 26
- Panel layout, 59-68
- Pantograph, 42-44
- Pattern recognition, 98
- Peripheral vision, 93-94
- Pictorial displays, 3, 6-9
- Plan-position-indicators, 28
- Pointer alignment, 65
- Pointer design, 22
  - moving, 3-4, 10-11
  - multiple, 6
  - alignment, 65
- Polaroid lighting for CRTs, 38-39
- Position indicators, 9
- Pre-exposure brightness, 34

- Printed materials, 56
- Qualitative reading, 1, 4
- Quantitative reading, 1,4
- Radar, see cathode-ray tubes
- Range aid methods (CRT), 41-43
- Range cursor, 42
- Range estimation, 40
- Range markers, 40
- Range ring numbering, 41
- Range ring spacing, 40
- Rear lighting, 85
- Reflectance, 38, 70-71, 82
- Representation of planes in space, 59-63
- Resolution, 29
- Scale design, 14-20
  - break, 10, 20
  - dimensions, 18-19
  - interpolation, 19
  - numbering, 14-17, 40-42
  - range, 14
  - simplicity, 20
- Sector scan, 28
- Selective spectrum lighting, 38-39
- Setting, 1, 4
- Shape coding, 21, 48-50
- Signal, see cathode-ray tubes
- Size, estimation of, 100
- Sloping panels, 60
- Specular glare, 77
- Stereo-depth coding, 53-57
- Stereoscopic acuity, 91
- Subjective scaling, 47
- Switch, location of 65
- Symbolic displays, 3-6, 10-13
- Tables, construction of, 58
- Tracking, 1, 4, 9
- Transilluminated instruments, 85
- Three coordinate displays, 45
- Velocity, estimation of, 90
- Viewing angle, 2, 64, 35
- Viewing distance, 2, 35, 64
- Vernier acuity, 90
- Visibility, 30-39, 76-79, 81-82, 87-99
  - adaptation level, 31, 81-82
  - signal duration, 35
  - signal size and brightness, 30
  - signal strength, 33
  - viewing angle, 35
  - viewing distance, 35
- Visual acuity,
  - color and, 95
  - contrast and, 89, 97
  - definition of, 72
  - glare and, 92
  - minimum perceptible, 89-90
  - minimum separable, 87-88
  - retinal position and, 93
  - stereoscopic, 91-92
  - vernier, 90-91
- Visual angle, 72
- Visual number coding, 51
- Warning devices, 25-26
- Warning lights, 25-26
- Word selection, 57
- Zero reader, 67
- Zone markings, 21

# BIBLIOGRAPHY

- Atkinson, W.H., Crumley, L.M., and Willis, M.P. A study of the requirements for letters, numbers, and markings to be used on trans-illuminated aircraft control panels: Part V. The comparative legibility of three fonts for numerals. *Naval Air Material Center Report TED Number NAMEL-609 Part 5*, 1952.
- Baker, C.A. and Vanderplas, J.M. Speed and accuracy of scale reading as a function of the number of range rings. *USAF WADC Technical Report* (In Preparation).
- Baker, Katherine, E. Some variables influencing vernier acuity. I. Illumination and exposure time. II. Wavelength of illumination. *J. opt. Soc. Amer.*, 1949, 39, 567-576.
- Barber, J.L., and Garner, W.R. The effect of scale numbering on scale reading accuracy and speed. *J. exp. Psychol.*, 1951, 41, 298-309.
- Bartlett, N.R. Target indication from the PPI of SG-1b (Model 50) radar. Systems Research Laboratory, *The Johns Hopkins University Report Number 166-I-24*, 1947.
- Bartlett, N.R. and Williams, S.B. Signal mark size and visibility of radar signals on a plan position indicator. Systems Research Laboratory, *The Johns Hopkins University Report Number 166-I-30*, 1947.
- Bartlett, N.R. and Sweet, A.L. Visibility on CRT screens: Signals on P-7 screen exposed for different intervals. *J. opt. Soc. Amer.* 1949, 39, 470-473.
- Berkley, C. Three dimensional representation on cathode-ray tubes. *Proc. I.R.E.*, Dec., 1948, 1530ff.
- Berry, R.N., Riggs, L.A., and Duncan, C.P. The relation of vernier depth discrimination to field brightness. *J. exp. Psychol.*, 1950, 40, 349-354.
- Blackwell, H.R. Contrast thresholds in the human eye. *J. opt. Soc. Amer.*, 1946, 36, 624-643.
- Blondel, A. and Rey, J. Sur la perception des lumieres breves a la limite de leur portee. *J. Phys.*, Paris, 1911, 1, 530-550.
- Bradley, J.V. Desirable control-display relationships for moving-scale instruments, *WADC Technical Report 54-423*, 1954.
- Brown, F.R. A study of the requirements for letters, numerals and markings to be used on trans-illuminated aircraft control panels: Part IV. Legibility of uniform stroke capital letters as determined by size and height to width ratio and as compared to Garamond Bold. *Naval Air Material Center Report TED NAMEL 609-4*, 1953.
- Brown, K.T., and Grether, W.F. The effects of pure red and low color temperature white instrument lighting upon dark adapted visual thresholds. *WADC Technical Report No. 6470*, 1952.
- Browne, R.C. Comparative trial of two attitude indicators. *British Flying Personnel Research Committee Report No. 611A*, 1945.



- Carter, L.F. A study of the best design of tables and graphs used for presenting numerical data. *USAF Air Material Command Memorandum Report Number TSEAA 694-1c*, 1946.
- Chalmers, E.L., Goldstein, M., and Kappauf, W.E. The effect of illumination on dial reading. *USAF Technical Report No. 6021*, 1950.
- Chapanis, A. How we see. *Human factors in undersea warfare*, Chapter I, Washington: National Research Council, 1949.
- Chapanis, A. Some aspects of operator performance on the VJ remote radar indicator. Systems Research Center, *The Johns Hopkins University Report Number 166-I-91*, 1949.
- Chapanis, A., Garner, W.R., and Morgan, C.T. *Applied experimental psychology*. New York: Wiley & Sons, Inc., 1949.
- Chapanis, A. and Leyzorek, M. Accuracy of visual interpolation between scale markers as a function of the number assigned to the scale interval. *J. exp. Psychol.*, 1950, 40, 655-667.
- Cobb, F.W., and Moss, F.K. The four variables of the visual threshold. *J. Franklin Inst.*, 1928, 205, 831-847.
- Cole, E.L., McIntosh, B.B., and Grether, W.F. Brightness levels of three instrument lighting systems used by pilots flying at night. *USAF Technical Report No. 6031*, 1950.
- Connell, Shirley C. The relative effectiveness of presenting numerical data by the use of scales and graphs. *USAF Air Material Command Memorandum Report Number TSEAA 694-1m*, 1947.
- Craik, K.J.W. and Macpherson, S.J. The effect of certain operating conditions on the visibility of PPI radar echoes. *Med. Res. Council, APRU, Psychol. Lab., Cambridge. APU 16*, 1945.
- Eastman Kodak Co. Influence of color contrast on visual acuity. *National Defense Research Committee; U.S. Office Scientific Research and Development; Report 4541*, 1944.
- Ferree, C.E., and Rand, G. Visibility of objects as affected by color and composition of light. Part II. With lights equalized in both brightness and saturation. *Person, J.*, 1931, 10, 108-124.
- Fitts, P.M., and Simon, C.W. The arrangement of instruments, the distance between instruments and the position of instrument pointers as determinants of performance in an eye-hand coordination task, *USAF Technical Report No. 5832*, 1952.
- Ford, A., Olson, M.W., Rigler, D., Dugan, G.E., and Getz, M.H. Single-operator signal tracking on ground radar. *USAF Technical Report Number 6370*, 1950.
- Ford, A., Rigler, D., and Dugan, G.E. Pantograph radar tracking: Point centering experiments. *USAF Technical Report Number 5969*, 1949.
- Gardner, J.F. Direction of pointer motion in relation to movement of flight controls: Cross pointer type instrument. *USAF Technical Report No. 6016*, 1950.

- Gardner, J.F., and Lacey, R.J., An experimental comparison of five different attitude indicators, *WADC Technical Report No. 54-32*, 1954.
- Garner, W.R., Hanes, R.M. and Reed, J.D. Calculation of bearing and range errors due to delays in transmission of radar information. Systems Research Laboratory, *The Johns Hopkins University Report Number 166-I-11*, 1947.
- Garner, W.R., Saltzman, D.C., and Saltzman, I.J. Some design factors affecting the speed of identification of range rings on polar coordinate displays. Systems Research Laboratory, *The Johns Hopkins University Report Number 166-I-95*, 1949.
- Gebhard, J.W. Accuracy of aligning the movable range marker with blips on a PPI. Systems Research Laboratory, *The Johns Hopkins University Report Number 166-I-46*, 1948.
- Gebhard, J.W. and Bilodeau, E.A. Appraisal of an experimental PPI presenting simulated bearing, range, and height information. Systems Research Laboratory, *The Johns Hopkins University Report Number 166-I-37*, 1947.
- Gilinsky, Alberta S. Perceived size and distance in visual space. *Psychol. Rev.*, 1951, 58, 460-482.
- Green, B.F., McGill, W.J., and Jenkins, H.M. The time required to search for numbers on large visual displays. Massachusetts Inst. of Tech., *Lincoln Laboratory Technical Report Number 36*, 1953.
- Grether, W.F. The effect of variations in indicator design upon speed and accuracy of altitude readings. *USAF Memorandum Report No. TSEAA 694-14*, 1947a.
- Grether, W.F. Discussion of pictorial versus symbolic aircraft instrument displays. *USAF Air Materiel Command Memorandum Report No. MCREXD-694-8B*, 1947b.
- Grether, W.F. Speed and accuracy of dial readings as a function of dial diameter and spacing of dial divisions. *USAF Air Materiel Command Memorandum Report Number TSEAA 694-1e*, 1947c.
- Haig, C. The course of rod adaptation as influenced by the intensity and duration of pre-adaptation to light. *J. gen. Physiol.*, 1941, 24, 735-751.
- Halsey, Rita, Chapanis, A. On the number of absolutely identifiable spectral hues. *J. opt. Soc. Amer.*, 1951, 41, 1057-1058.
- Halsey, Rita, and Chapanis, A. Experiments on the selection of colors for color coding purposes. *Minutes and Proceedings 32 Armed Forces NRC Vision Committee, April, 1953*, 35-41.
- Hanes, R.M., and Williams, S.B. Visibility of cathode-ray tubes: The effects of light adaptation. *J. opt. Soc. Amer.*, 1948, 38, 363-377.
- Handbook of human engineering data for design engineers. Tufts College, 1949.
- Hecht, S., Ross, S., and Mueller, C.G. The visibility of lines and squares at high brightnesses. *J. opt. Soc. Amer.*, 1947, 37, 500-507.

- Hill, N.E.G. The recognition of colored light signals which are near the limit of visibility. *Proc. phys. Soc.*, London, 1947, 59, 560-574.
- Hirsch, M.J., and Weymouth, F.W. Distance discrimination. V. Effect of motion and distance of targets on monocular and binocular distance discrimination. *J. Aviat. Med.*, 1947, 18, 594-600.
- Holway, A.H., and Jameson, Dorothea. *Good lighting for people at work in reading rooms and offices*. Boston: Harvard Business School, Division of Research, 1947.
- Howes, D.H. and Solomon, R.L. Visual duration threshold as a function of word probability. *J. exp. Psychol.*, 1951, 41, 401-410.
- Illuminating Engineering Society Lighting Handbook (2nd Ed.). New York: Illuminating Engineering Society, 1952.
- Kappauf, W.E. Design of instrument dials for maximum legibility. Part V. Origin location, scale break, number location and contrast direction. *USAF Technical Report No. 6366*, 1951.
- Kappauf, W.E., and Smith, W.M. Design of instrument dials for maximum legibility. Part III. Some data on the difficulty of quantitative reading in different parts of a dial. *USAF Technical Report No. 5914*, 1950.
- Kraft, C.L. and Fitts, P.M. A broad-band-blue lighting system for radar air traffic control centers. *WADC Technical Report 53-416*, 1954.
- Loucks, R.B. An experimental evaluation of the interpretability of various types of aircraft attitude indicators. In P.M. Fitts (ed.), *Psychological research on equipment design*, AAF, *Aviat. Psychol. Prog. Res. Rep.*, Report No. 19, 1947.
- Loucks, R.B. An experimental study of the effectiveness with which novices can interpret a localizer-glidepath approach indicator. *USAF Technical Report No. 5959*, 1949.
- Lund, M.W. Selective spectral lighting for CIC areas. U.S. Navy Electronics *Laboratory Report No. 337*, 1953.
- Lythgoe, R.J. The measurement of visual acuity. *Spec. Rep. Sev. med. Res. Coun.*, London, 1932, 173, 85pp.
- Mackay, D.M. Projective three dimensional displays. *Electronic Engineering*, July, 1949, 281 ff.
- Mandelbaum, J., and Sloan, Louise. Peripheral visual acuity: with special reference to scotopic illumination. *Amer. J. Opthal.*, 1947, 30, 581-588.
- McFarland, R.A., Holway, A.H., and Hurvich, L.M. *Studies of visual fatigue*. Graduate School of Business Administration, Harvard University. Boston, Mass., 1942.
- Mead, L.C. The influence of size of test stimuli, interpupillary distance, and age on stereoscopic depth perception. *J. exp. Psychol.*, 1943, 33, 148-158.

- Moon, P., and Spencer, D.E. Visual data applied to lighting design. *J. opt. Soc. Amer.*, 1944, 34, 605-617.
- Mote, F.A. and Riopelle, A.J. The effect of varying the intensity and duration of pre-exposure upon foveal dark adaptation in the human eye. *J. gen. Physiol.*, 1951, 34, 657-674.
- Mote, F.A. and Riopelle, A.J. The effect of varying the intensity and duration of pre-exposure upon subsequent dark adaptation in the human eye. *J. comp. Psychol. and Physiol.*, 1953, 46, 49-56.
- Munsell, A.H. *Book of Color*. Baltimore, Md., 1942: Munsell Color Book Company Inc.
- Oberly, H.S. The range of visual attention, cognition, and apprehension. *Amer. J. Psychol.*, 1924, 35, 332-352.
- Parker, E. and Wallis, P.R. Three dimension cathode-ray tube displays. *J. inst. Elec. Eng.*, 1948, 95, 371 ff.
- Paterson, D.G., and Tinker, M.A. *How to make type readable*. New York: Harper & Bros., 1940.
- Peskin,, J.C., and Bjornstad, Jeanne The effect of different wavelengths of light on visual sensitivity. *USAF Air Materiel Command Memorandum Report No. MCREXD-694-93A*, 1948.
- Radar Intelligence. *Air Force Manual 205-15*. Washington D.C., Headquarters, USAF, 1945.
- Reed, J.D. and Bartlett, N.R. Comparison of manual and standard methods of target indication. Systems Research Laboratory, *The Johns Hopkins University Report Number 166-8-9*, 1947.
- Reese, E.P., Reese, T.W., Volkman, J., and Corbin, H.H. Psychological research summary report 1946-1952. *Mount Holyoke College SDC Report Number 131-I-5*, 1953.
- Sabeh, R., Jorve, W.R., and Vanderplas, J.M. Shape coding of instrument code markings. *WADC Technical Report* (In Preparation).
- Schmitt, O.H. Cathode ray presentation of three dimensional data. *J. appl. Phys.*, 1947, 18, 819 ff.
- Senders, V.L. and Cohen, J. The influence of methodology on research on instrument displays. *WADC Technical Report 53-93*, 1953.
- Sleight, R.S. The relative discriminability of several geometric forms. *J. exp. Psychol.*, 1952, 43, 424-328.
- Sloan, Louise Rate of dark adaptation and regional threshold gradient of the dark adapted eye: physiologic and clinical studies. *Amer. J. Ophthal.*, 1947, 30, 705-720.
- Spragg, S.D.S., and Rock, M.L. Dial reading performance as related to illumination variables: I. Intensity. *USAF Air Materiel Command Memorandum Report No. MCREXD-694-21*, 1948.
- Stevens, S.S.,(Ed.). *Handbook of experimental psychology*. New York: Wiley & Sons, Inc., 1951.
- Thorndike, E.L., and Lorge, I. *The teacher's word book of 30,000 words*. New York: Bureau of Publication, Teachers College, Columbia Univ., 1944.

Tuft's Handbook. Handbook of Human Engineering Data for design engineers. Tufts College SDC Report 199-I-1, 1949.

Van Saun, H.R. The comparative interpretability of two methods of presenting bombing information on radar. USAF Air Materiel Command Memorandum Report Number TSEAA 694-5, 1946.

Vernon, Magdeline D. Scale and dial reading. Medical Research Council Unit, University of Cambridge, England, Report No. A.P.U. 49, 1946.

Warrick, M.J., and Grether, W.F. The effect of pointer alignment on check reading of engine instrument panels. USAF Air Materiel Command Memorandum Report No. MOREXD-694-17, 1948.

White, W.J. The effect of pointer design and pointer alignment on the speed and accuracy of reading groups of simulated engine instruments. USAF Air Materiel Command Technical Report. No. 6014, 1951.

White, W.J. The effect of dial diameter on ocular movements and speed and accuracy of check reading groups of simulated engine instruments. USAF Technical Report No. 5826, 1949.

White, W.J., and Sauer, S. Scale design for reading at low brightness, WADC Technical Report Number 53-464, 1954.

Williams, S.B. The effect of certain illumination variables on the visibility of signals on cathode ray screens. Amer. Psychol., 1947, 2, 347. (abstract)

Williams, S.B. Visibility on radar scopes. Chapter 4 in Human Factors in Undersea Warfare, National Research Council, Washington, D.C., 1949.

Williams, S.B. and Hanes, R.M. Visibility on cathode-ray tube screens: Intensity and color of ambient illumination. J. Psychol., 1949, 27, 231-244.

WADC TR 54-160