

**USE OF DICHROMATIC EARPIECE DENSITOMETRY FOR
DETERMINATION OF CARDIAC OUTPUT**

*JOHN H. REED, JR.
EARL H. WOOD*

FOREWORD

The studies on which this report is based were accomplished in the cardiovascular and human centrifuge laboratories of the Mayo Graduate School of Medicine (University of Minnesota), Rochester, Minnesota under the direction of Dr. Earl H. Wood under Air Force Contract No. AF 33(657)-8899, NASA Interagency Transfer Fund R-43, Project No. 7222, "Biophysics of Flight".

Dr. Alvin S. Hyde, Multienvironment Division, Biophysics Laboratory, Aerospace Medical Research Laboratories was the contract monitor.

These studies were supported in part by research grants: Nsg-327 from the National Aeronautics and Space Administration, H-3532 from the National Institutes of Health of the United States Public Health Service, and CI 10 from the American Heart Association.

Dr. John H. Reed, Jr., Fellow, Mayo Graduate School of Medicine was supported during the period of this study by a Postdoctoral Research Fellowship from the National Institutes of Health. Work on this project started on October 1, 1963 and continued until November 1, 1964.

This study was made possible by the unstinting co-operation of many of our technical and professional colleagues in the Section of Physiology, among which Miss Lucille Cronin, Donald Hegland, Irene Donovan and Mrs. Jean Frank are deserving of particular mention. The valuable technical assistance of Mr. Robert Floyd and Mr. George Sedivy of the Medical Equipment Division of Waters Corporation, Rochester, Minnesota is also acknowledged.

This technical report has been reviewed and is approved.

J. W. HEIM, PhD
Technical Director
Biophysics Laboratory

ABSTRACT

In situations which forbid direct arterial sampling such as space flight, estimation of cardiac output by ear densitometer may be justifiable. Compensation for changes in blood content and saturation recommend dichromatic densitometry. Simultaneous dilution curves following injection of 5 milligrams indocyanine green into the superior vena cava of nine healthy subjects and five patients during rest and exercise were recorded by a dichromatic ear densitometer, a conventional ear oximeter and a cuvette coupled to the radial artery. Simultaneous single and double scale operation was used. Calibration of earpieces assumed linearity for extrapolation of the deflection at 90 seconds after injection on the basis of dye concentration estimated from hematocrits and spectrophotometry of plasma from simultaneous blood samples both from the radial artery and an upper arm vein. About 30% of monochromatic ear oximeter curves were unsatisfactory due to variations in blood content of the ear usually associated with respiration; these artifacts were absent in dichromatic earpiece curves. Using the cuvette as reference, cardiac output values gave no systematic variation when calibrated from arterial blood. The standard deviations of differences by ear oximeter was 31% and by dichromatic ear densitometer was 14%. When calibrated by venous blood, the standard deviations from cuvette were 31 and 22 per cent, respectively and the dichromatic densitometer values averaged 7% less than simultaneous cuvette values. With exercise, oxygen consumption increased an average of 654 ml./minute (452-793) from resting values with concurrent rise in cardiac output of 5.3 (3.9-7.2) by cuvette and 5.7 (5.0-6.8) L./minute by dichromatic earpiece. The dichromatic earpiece densitometer showed a linear relationship between its calibration factor for dye (cm. deflection/mg. dye/L. of blood) and the relative blood content of the ear determined by inflating its pressure capsule to 250 millimeters of mercury. It is concluded that dichromatic earpiece densitometry may be useful in situations where more reliable methods are impossible. Furthermore, by use of a previously calibrated earpiece, it appears possible, to obtain values for cardiac output without the necessity of withdrawal and spectrophotometric analysis of blood samples for calibration.

Contrails

USE OF DICHROMATIC EARPIECE DENSITOMETRY FOR DETERMINATION OF CARDIAC OUTPUT*

The determination of cardiac output from dye-dilution curves according to the method of Hamilton is accepted as a reliable technic (1). Early methodology required the analysis of blood samples withdrawn at short intervals from a systemic artery (1,2). Later the use of continuous recording photoelectric cells was introduced (3,4), thus simplifying the technic considerably. Cannulation of an artery for blood samples is not always advantageous and in some cases it is prohibitive. In situations where direct sampling is prohibitive, estimation of cardiac output by indirect earpiece densitometry may be justified. Earpiece densitometry has been reported intermittently since 1950 (5,6,9,10,11), but the use of the earpiece has not been widely accepted. This has been due to the difficulty in calibration of the device and because the reliability of the ear as a recording site has been questioned (7). Dichromatic densitometry has been suggested as a possible way to increase reliability (8). This paper describes the comparison of dye-dilution curves recorded simultaneously from a dichromatic earpiece densitometer, a monochromatic earpiece densitometer and a direct arterial sampling cuvette.

METHODS

Figure 1 is included for a review of the relationships between the transmission of light through blood and dye along with the relative sensitivity of the photocells used in these instruments as a function of wave length.

* Presented at the American Physiological Society, Providence, Rhode Island, September 5, 1964.

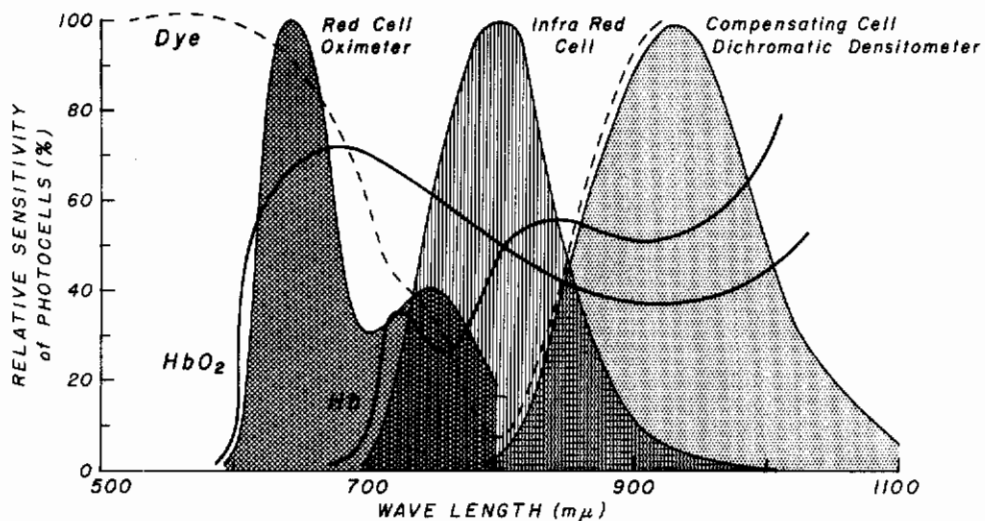

Figure 1 Comparison of the spectral sensitivities of photocell filter assemblies of earpiece oximeter and densitometers and the relative light transmission of hemoglobin and indocyanine green.

The spectral transmission of oxygenated and reduced blood with an isosbestic point at 800 millimicrons is shown in the dark heavy lines. Indocyanine green's transmission is shown as the dashed line and is minimal at about 800 millimicrons. The three peaks represent the spectral sensitivities of the photocells. The infrared cell has a sensitivity which is greatest where indocyanine green's transmission is least. This cell is referred to as the detecting cell. The dichromatic ear densitometer has a compensating cell whose spectral sensitivity peaks at 925 millimicrons. The monochromatic densitometer has a second photocell, the red cell, with a peak sensitivity at 640 millimicrons. This photocell serves as the detecting cell when the instrument is used as an oximeter and is not used for recording of dilution curves.

Two earpiece densitometers were used in this study, one being a dichromatic and the other a monochromatic instrument. The dichromatic earpiece densitometer contains two photocells, one of which is sensitive to dye (detecting cell) and one which is insensitive to dye (compensating cell). Both cells are approximately equally reactive to changes in transillumination of the ear caused by changes in blood content, hematocrit or other non-specific effects (12), but one is sensitive to dye; the other is not. Both cells are relatively insensitive to changes

Contrails

in oxygen saturation of the transilluminated blood. Compensation for non-specific changes in the ear unrelated to dye is obtained by using these cells in reverse polarity to each other. The "bucking" of the detecting cell against the compensating cell provides a stable baseline from which the "end-tail method of calibration" of a dye such as indocyanine green* can be measured even though the removal rate of dye from the arterial blood is rapid. The circuit diagram for the dichromatic earpiece densitometer is shown in the left panel of Figure 2.

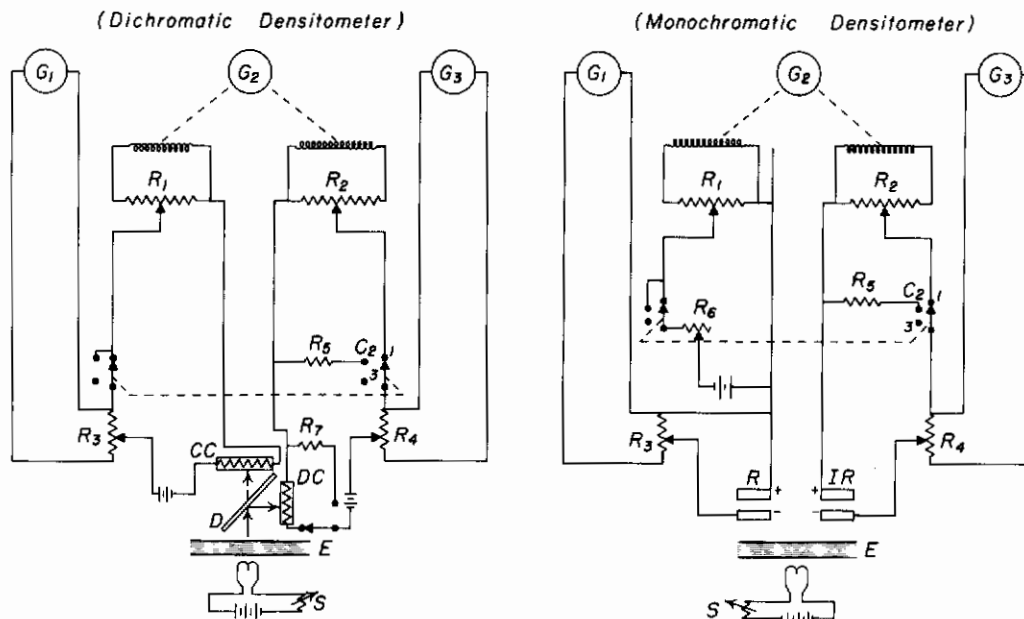

Figure 2 Diagram of circuits used for dichromatic earpiece densitometer (left panel) and monochromatic earpiece and cuvette densitometers (right panel). G_2 indicates the single-scale galvanometers which record dye concentration, G_1 and G_3 are the double scale galvanometers. D indicates the dichroic mirror and CC and DC, the compensating and detecting photo-resistive cells of the dichromatic earpiece, respectively. IR and R indicate the infrared and red photo-voltaic cells of the monochromatic densitometers. The output of the red cell is recorded by the double scale galvanometer (G_1) only and does not effect galvanometer G_2 which records dye concentration. E indicates the cartilaginous pinna of the ear or the lumen of the cuvette which are transilluminated by the light source which is regulated by potentiometer S. C indicates the control switch position for recording dye concentration for the two respective circuits, C_2 the switch position used for setting the sensitivity of the circuit to a standard value and C_3 the position for setting the mechanical zero position of the single scale galvanometer.

* The indocyanine green dye was supplied through the courtesy of Hynson, Westcott and Dunning under the trade name Cardiogreen.

Contrails

Note that the use of a dichroic mirror in this earpiece allows for both cells to view the same optical pathway of the ear, thus eliminating the assumption that two portions of the ear react equally. The dichromatic earpiece densitometer utilizes photo-resistive cells whose change in resistance with change in light intensity is nonlinear. It is, therefore, necessary that the initial resistance of the photocell be equivalent from subject to subject. This is accomplished by adjusting the light voltage until the resistance of the detecting cell matches a known resistance (see Figure 2, left panel).

The monochromatic earpiece densitometer circuit diagram is shown in the right hand panel of Figure 2. Note that in place of a compensating photocell a constant current from a battery source is used in opposite polarity in the single scale circuit. As long as the conditions within the transilluminated portion of the ear remain constant or change very little this method of compensation is adequate, but conditions in most ears do not remain stable; hence baseline instability is frequently encountered. The third densitometer is a cuvette coupled to the radial artery. The circuitry for this is similar to the monochromatic circuit shown in the left hand panel of Figure 2. The objections to the use of a monochromatic earpiece densitometer do not hold to the same degree when a monochromatic cuvette is used since blood flow is relatively stable and the depth of the optical pathway of the cuvette is fixed.

The earpieces were placed on the ear and switched on at least ten minutes prior to use to allow "system" thermal equilibrium. The only manipulation of the ear was to cleanse the pinna with an alcohol sponge, rubbing vigorously for 10 to 15 seconds prior to positioning the earpiece. A black cloth was used to eliminate extraneous light.

CALIBRATION OF EARPIECES

Calibration of the ear curves assumed linearity of deflection for dye concentration. The deflection from baseline at 90 to 100 seconds after each dye injection (see Figure 3) was assumed to be due to the concentration of indocyanine green dye determined independently on a Beckman Du Spectrophotometer, from blood samples withdrawn simultaneously from the right radial artery and from the left brachial vein.

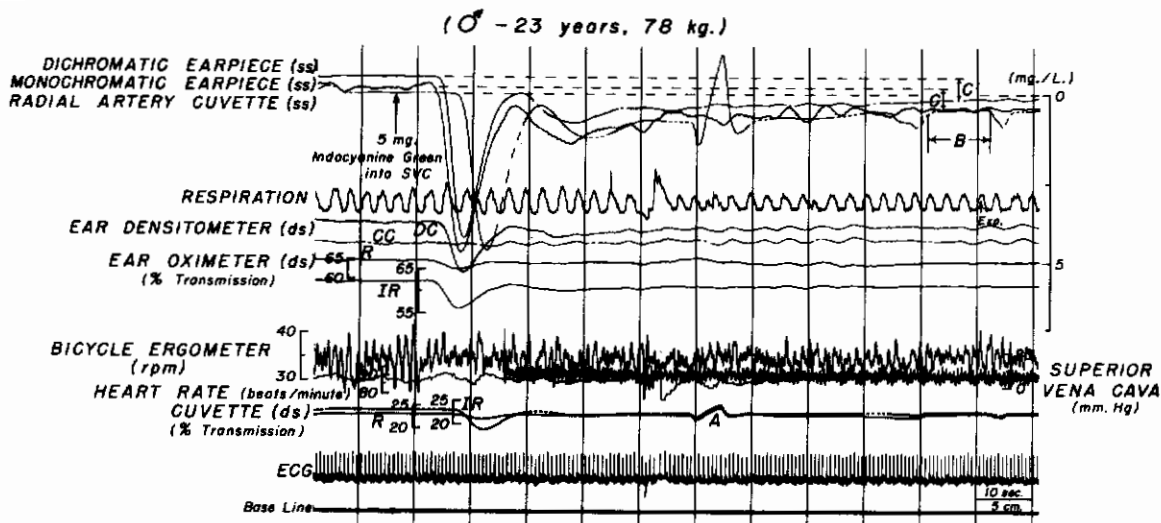

Figure 3 A photokymographic record showing from above downwards the dilution curves recorded simultaneously from the dichromatic and monochromatic ear densitometers and the radial artery cuvette. The double scale recordings (ds) from each cell are shown below. CC and DC indicate the recordings of the output of the compensating and detecting cells, respectively of the dichromatic earpiece while R and IR indicate the transmission of red ($640 \text{ m}\mu$) and infrared light ($800 \text{ m}\mu$) of the ear and arterial blood recorded by the monochromatic earpiece and the radial artery cuvette, respectively. B indicates the 10-second period starting one and one-half minutes after the indicator was injected during which arterial and venous blood samples were withdrawn for spectrophotometric determination of the concentration of indocyanine green. These concentration values were related to the deflections C and C¹ recorded during this period to establish the calibration factor for the dichromatic and monochromatic earpieces, respectively. (A) indicates a period of temporary interruption of blood flow through the radial artery cuvette during a change in sampling syringes. Note the unstable baseline in the uncompensated monochromatic ear dye curve due to changes in blood content of the ear, as compared to the stable baseline of the compensated dichromatic ear densitometer. Note also that the output of the compensating cell of the dichromatic earpiece is unaffected by the dye.

Contrails

The value for the concentration of dye in venous and arterial blood was determined from the difference in plasma optical density at 800 m μ of blood samples withdrawn immediately prior to injection of dye and 90 seconds after. Calibration curves for the Beckman Du Spectrophotometer for indocyanine green were based on measurements of the optical density of plasma from aliquots of the subject's blood in which known quantities of dye were diluted. Hematocrits were done and corrections of plasma to whole blood concentrations were computed. The ratio of the densitometer deflection in centimeters and the concentration of dye per liter of blood constituted the calibration factor then used in computing cardiac output by the standard Stewart-Hamilton formula. Figure 4 shows successive recordings from a subject and illustrates the experimental procedure.

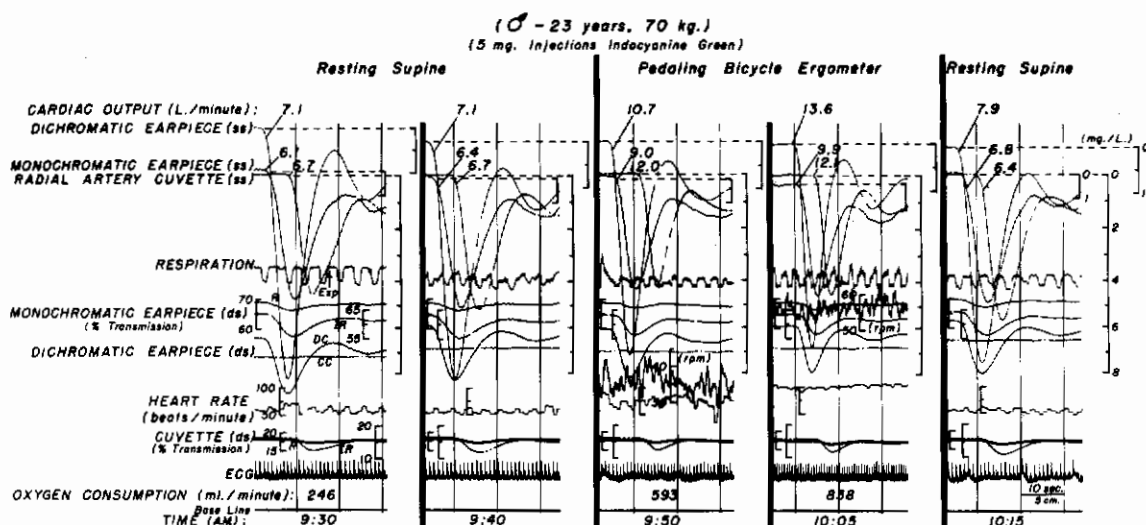

Figure 4 Comparison of dilution curves recorded simultaneously from the right radial artery and each ear following 5-milligram injections of indocyanine green into the superior vena cava of a healthy young man when at rest and while pedalling a bicycle ergometer from the supine position.

The time of each injection is given at the bottom of each panel along with the rate of oxygen consumption during the initial period of rest and during the last minute of two 5-minute periods of exercise at the two different rates indicated by the rate of rotation (rpm) of the bicycle. The estimated values for cardiac output from each dilution curve are given at the top of each panel. See legend of Figure 3 for definition of symbols.

The subjects were prepared by percutaneous insertion of a number 5 Lehman catheter into the superior vena cava via the right antecubital vein. A number 20 thin-wall needle was then inserted into the right radial artery and connected to a cuvette through which blood was withdrawn by a motor driven syringe at 25 ml./minute. A short polyethylene catheter was inserted percutaneously into the left brachial vein approximately 10 centimeters above the antecubital fossa for withdrawal of venous blood samples for calibration purposes. Dye curves were obtained at rest concomitantly with measurement of the rate of oxygen consumption as shown in the first two panels of Figure 4. Then curves were obtained at two levels of exercise with their associated oxygen consumption as shown in the next two panels of the figure. Then a resting curve was repeated 10 minutes after exercise as shown in the last panel of Figure 4.

RESULTS

Comparison of the cardiac output values obtained simultaneously from the three devices are depicted in figures 5 and 6. Figure 5 is a comparison of the values obtained by monochromatic earpiece densitometry and by direct arterial sampling via the cuvette densitometer.

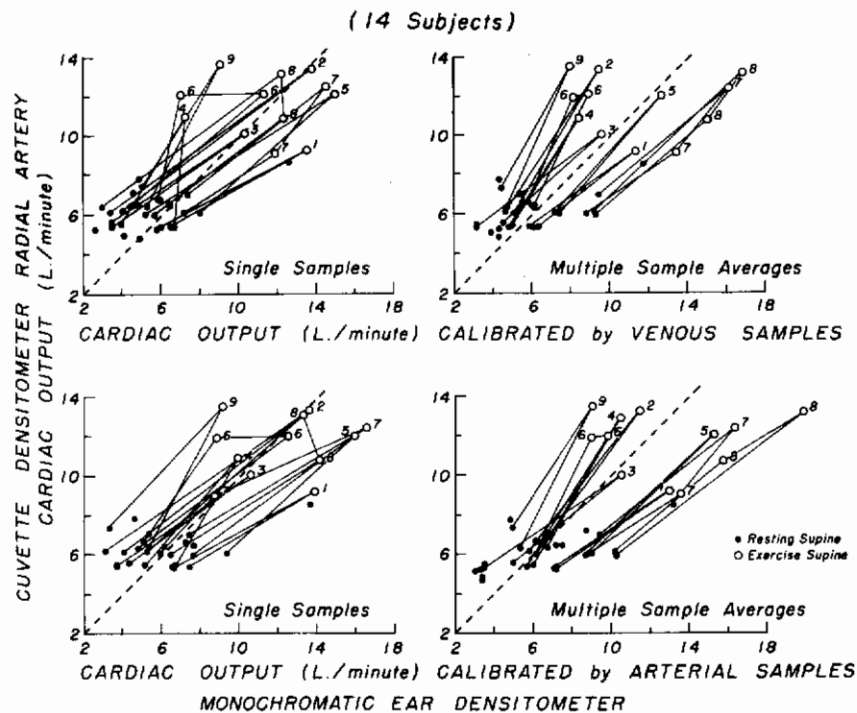

Figure 5 Comparison of cardiac output values estimated from dilution curves of indocyanine green recorded simultaneously from a radial artery cuvette and a monochromatic ear densitometer.

Contrails

The earpiece curves were calibrated on the basis of spectrophotometric determination of indocyanine green concentration in venous (top panels) and arterial blood samples (bottom panels) withdrawn one and one half minutes after injection of the dye. Each of the earpiece values in the left panels was based on the analysis of the respective arterial or venous blood sample withdrawn after each indicator injection. The values in the right panels were based on the average of the analysis of all arterial or venous blood samples withdrawn from each respective subject. The numerals indicate individual subjects. The dashed line is the line of identity.

Each point is based on simultaneous cardiac output values from a single 5-milligram injection of indocyanine green. Values from each earpiece curve were calculated in four ways as exemplified by the four panels of Figure 5. The earpiece cardiac output value shown in the lower left-hand panel was computed from a calibration factor derived from individual arterial blood samples. There was no systematic difference between paired earpiece and cuvette values; however, the standard deviation of ± 31 per cent is large. When individual venous blood samples were used to obtain the calibration factor as in the upper left-hand panel, the degree of variability was similar (i.e., standard deviation of ± 31 per cent). When the single arterial or venous calibration factors were averaged for each subject as shown in the right-hand panels, the degree of variability was again similar and no systematic difference was demonstrated. The thin lines connect individual rest and exercise values for each subject, so that the degree of correlation between the changes in output from rest to exercise as determined by the earpiece and direct arterial sampling can be seen.

Figure 6 shows the comparison of the cardiac output values by the dichromatic ear densitometer plotted against the values from the cuvette densitometer in a similar manner to the last figure.

Figure 6 Comparison of cardiac output values estimated from dilution curves recorded simultaneously from a radial artery cuvette and a dichromatic ear densitometer. See legend of Figure 5 and text for further details.

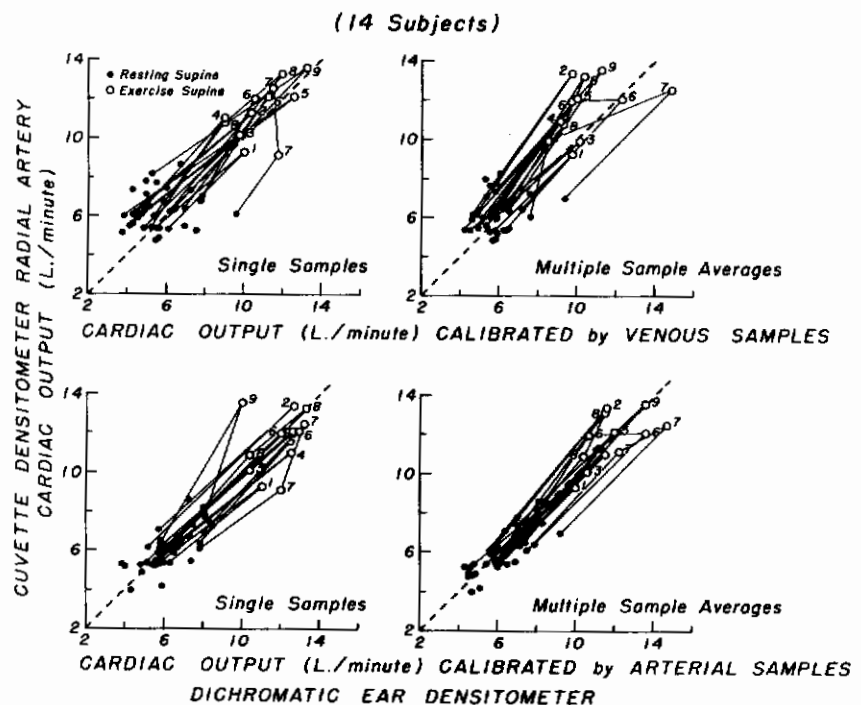

Contrails

The lower left-hand panel is the plot based on single sample arterial calibration. There was no systematic difference between the earpiece and the cuvette values, and the standard deviation of the differences of 14 per cent was less than half of that for monochromatic earpiece values. When single venous calibration blood samples were used, a systematic under-estimation of 7 per cent was obtained and the variability (SD of 22 per cent) was increased. When an average arterial or venous calibration for each subject was used (i.e., right panels) the calculated variabilities were somewhat decreased, the standard deviations being 12 and 17 per cent, respectively. The lines connecting individual rest and exercise values for each subject indicate a closer correlation between the changes in cardiac output by the dichromatic earpiece related to the direct arterial sampling than was obtained with the monochromatic device.

The monochromatic ear densitometer would show considerably less variability if only curves with stable baselines were used. This, however, would have necessitated dropping about 30 per cent of all curves recorded by the monochromatic device. In some individuals, changes in blood content of the ear with respiration caused baseline instability of such a degree that accurate measurements were precluded in all curves. For this reason dichromatic ear densitometry is necessary.

It would be highly desirable if a calibration factor for the dichromatic earpiece could be estimated for each subject without the withdrawal of a blood sample. It seemed reasonable that such a calibration factor might be related to the amount of blood being transilluminated in the optical pathway of the earpiece. An estimation of the blood content of the transilluminated portion of the ear of each subject was, therefore, obtained by measurement of the difference in output of the infrared cell when the ear was in the normal blood containing state and when the transilluminated portion was rendered essentially bloodless by inflating the pressure capsule to over 200 millimeters of mercury pressure.

Figure 7 shows the relationship of the relative blood content of the ear of each subject plotted on the abscissa to each subject's average arterial calibration factor plotted on the ordinate.

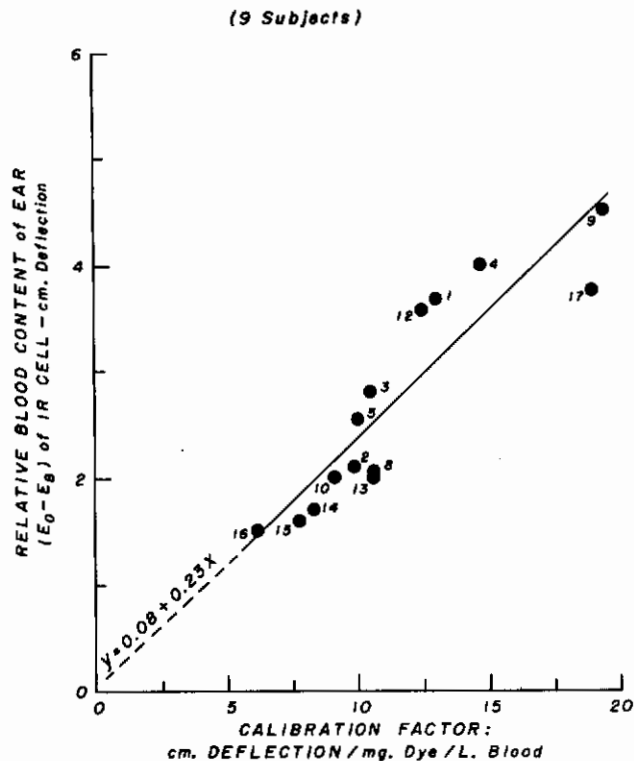

Figure 7 The relation of the calibration factor of a dichromatic ear densitometer for indocyanine green to the relative blood content of the ear in the optical path of the earpiece. E_0 indicates the galvanometer reading obtained when blood was excluded from the optical path of the earpiece by inflating its pressure capsule to 250 millimeters of mercury. E_B indicates the galvanometer reading obtained with the ear in the normal blood containing state. The calibration factor for each subject is based on the average of the analysis of the arterial samples withdrawn after each injection in this subject. The numerals designate the individual subjects.

The relatively close correlation between the calibration factors determined by analyses of arterial blood and the relative blood content of the ear determined by the earpiece is evident. The standard deviation of the differences in earpiece and arterial sample calibration factors was 12 per cent. A comparison of simultaneous cardiac output values using the earpiece calibration factor with conventional arterial cuvette densitometry values is shown in the left panel of Figure 8.

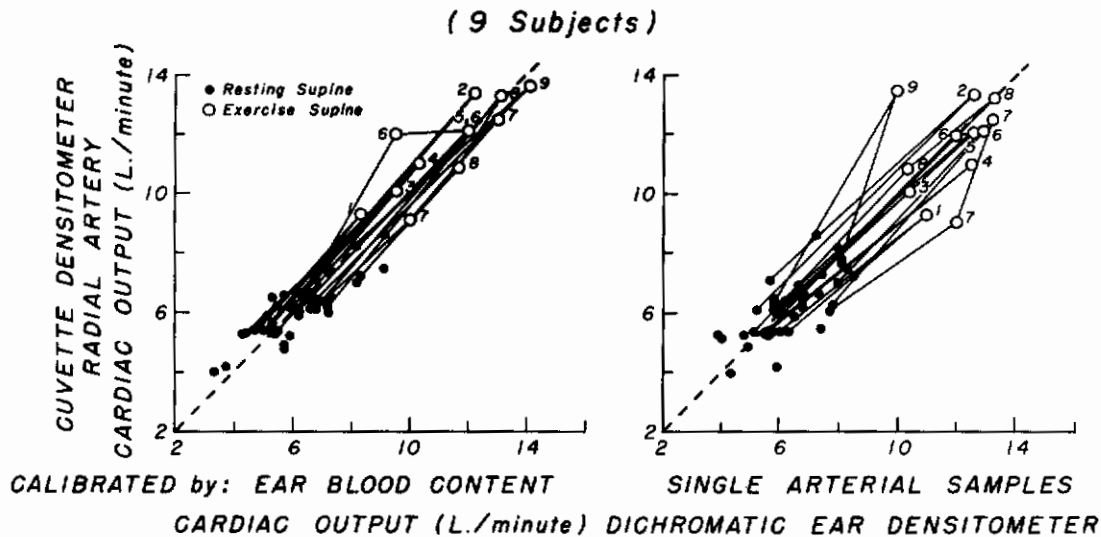

Figure 8 Comparison of cardiac output values estimated from dilution curves recorded simultaneously from a radial artery cuvette and a dichromatic ear densitometer.

The ear densitometer values in the left panel were calibrated on the basis of the relationship (Figure 7) between the blood content of the ear and the sensitivity of the earpiece to indocyanine green. Each value in the left panel is based on an analysis of an arterial blood sample withdrawn following each dilution curve. The numerals designate individual subjects. See Figure 5 and the text for further details.

The right panel of Figure 8, which is included for comparative purposes, is similar except that the earpiece cardiac output values are based on calibration factors determined from single arterial samples. The standard deviation of the differences between earpiece and cuvette densitometer values is 9 per cent when the earpiece blood content factor is used as compared to 14 per cent when an arterial sample calibration factor for each curve was used. It, therefore, appears that once the relationship has been established between the sensitivity of the earpiece to dye and relative blood content of the ear that further calibration factors can be estimated from the instrument itself without the necessity of withdrawing blood samples.

DISCUSSION

The pinna of the flushed ear provides an easily accessible site in which to view the optical events taking place in the circulating arterial blood. The use of the pinna of the ear for oximetry and densitometry has been studied and advocated by several investigators (6,9,10,11), yet the use of the photoelectric earpiece for quantitative purposes has not been widely accepted. This has occurred partly because of the fact that the methodology is indirect and partly

Contrails

because earpiece densitometry is difficult to quantitate. The disadvantage of indirect as opposed to direct methods is lessened if it could be shown that the indirect method provides reproducible and reliable results. The disadvantages lessen even more if the methodology in the indirect method is also simpler and time saving. It has been shown in this study that once the dichromatic earpiece densitometer has been calibrated by the end-tail method and compared to simultaneous cuvette dye dilution curves there is a relationship between relative blood content of the ear and calibration factor. With the use of this relationship, determinations of cardiac output can be accomplished without the necessity of withdrawing blood samples.

The necessity for good compensation for specific and non-specific changes in ear transillumination unrelated to dye is illustrated by comparison of results of the monochromatic earpiece to the dichromatic earpiece. It should be noted that all the curves from each instrument were analyzed regardless of quality and none were removed from the sample number. Selection of dye curves could improve the standard deviation of percentage differences, but would give only a false index of reliability and reproducibility.

REFERENCES

1. Hamilton, W. F., Riley, R. L., Attyah, A. M., Cournand, A., Fowell, D. M., Himmelstein, A., Noble, R. P., Remington, J. W., Richards, D. W., Wheeler, N. C. and Witham, A. C.: Comparison of the Fick and Dye Injection Methods of Measuring the Cardiac Output in Man. *Am. J. Physiol.* 153:309-321, 1948.
2. Werko, L., Lagerloff, H., Bucht, H., Wehle, B., Holmgren, A.: Comparison of the Fick and Hamilton Methods for the Determination of Cardiac Output in Man. *Scandinav. J. Clin. & Lab. Invest.* 1:109-113, 1949.
3. Wood, E. H. and Geraci, J. E.: Photoelectric Determinations of Arterial Oxygen Saturation in Man. *J. Lab. & Clin. Med.* 34:387-401, 1949.
4. Nicholson, J. W., III, Burchell, H. B. and Wood, E. H.: A Method for the Continuous Recording of Evan's Blue Dye Curves in Arterial Blood and its Application to the Diagnosis of Cardiovascular Abnormalities. *J. of Lab. & Clin. Med.* 37:353-364, (March) 1951.
5. Knutson, J. R. B., Taylor, B. E., Ellis, E. J. and Wood, E. H.: Studies in Circulation Time with the Aid of the Oximeter. *Proc. Staff Meet., Mayo Clinic* 25:405-412, 1950.
6. Beard, R. F., Nicholson, J. W., III and Wood, E. H.: Application of an Ear Oximeter to Estimation of Cardiac Output by the Dye Method in Man. *J. of Lab. & Clin. Med.* 36:798, 1950. (abstract)
7. Wood, E. H., Swan, H. J. C., Helmholtz, H. F., Jr.: Recording and Basic Patterns of Dilution Curves: Normal and Abnormal. *Proc. Staff Meet., Mayo Clinic* 32:464-477, (September 4) 1957.
8. Sutterer, W. F., Wood, E. H.: A Compensated Dichromatic Densitometer for Indocyanine Green. *IRE Trans. on Bio-Med. Elect., Vol. BMEQ, No. 2:* 133-137, (April) 1962.
9. Gilmore, H. R., Hamilton, M., Kopelman, H. and Sommer, L. S.: The Ear Oximeter. Its Use Clinically and in the Determination of Cardiac Output. *Brit. Heart Jour.* 16:301-310, 1954.
10. McGregor, W., Sekelj, P., Adam, W.: The Measurement of Cardiac Output Using Simultaneous Ear Oximeter and Whole Blood Cuvette Techniques. *Circulation Res.* 9:1083-1088, 1961.
11. Gabe, I. T. and Shillingford, J. P.: The Photoelectric Earpiece Techniques for Recording Dye Dilution Curves. *Brit. Heart Jour.* XXIII:271-280, 1961.
12. Sinclair, J. P., Sutterer, W. F., Fox, I. J. and Wood, E. H.: Apparent Dye-Dilution Curves Produced by Injection of Transparent Solutions. *J. Appl. Physiol.* 16:669-673, (July) 1961.

Contrails

UNCLASSIFIED
Security Classification

DOCUMENT CONTROL DATA - R&D		
(Security classification of title, body of abstract and indexing annotation must be entered when the overall report is classified)		
1. ORIGINATING ACTIVITY (Corporate author) The Mayo Clinic and Mayo Graduate School of Medicine Rochester, Minnesota	2a. REPORT SECURITY CLASSIFICATION UNCLASSIFIED	
	2b. GROUP N/A	
3. REPORT TITLE USE OF DICHROMATIC EARPIECE DENSITOMETRY FOR DETERMINATION OF CARDIAC OUTPUT		
4. DESCRIPTIVE NOTES (Type of report and inclusive dates) Final report, 1 October 1963 - 1 November 1964		
5. AUTHOR(S) (Last name, first name, initial) Reed, John H., Jr. Wood, Earl H.		
6. REPORT DATE December 1964	7a. TOTAL NO. OF PAGES 13	7b. NO. OF REFS 12
8a. CONTRACT OR GRANT NO. AF 33(657)-8899 b. PROJECT NO 7222 c. d.	9a. ORIGINATOR'S REPORT NUMBER(S) 9b. OTHER REPORT NO(S) (Any other numbers that may be assigned this report) AMRL-TR-64-134	
10. AVAILABILITY/LIMITATION NOTICES Qualified requesters may obtain copies of this report from DDC. Available, for sale to the public, from the Clearinghouse for Federal Scientific and Technical Information, CFSTI (formerly OTS), Sills Bldg, Springfield, Virginia 22151.		
11. SUPPLEMENTARY NOTES	12. SPONSORING MILITARY ACTIVITY Aerospace Medical Research Laboratories, Aerospace Medical Division, Air Force Systems Command, Wright-Patterson AFB, Ohio	
13. ABSTRACT Dye-dilution curves were recorded simultaneously by a monochromatic ear-piece densitometer, a dichromatic earpiece densitometer and a cuvette densitometer through which blood was sampled continuously from a radial artery. Comparison of cardiac output values were made using the direct coupled arterial cuvette as a standard in nine healthy subjects during three periods of rest and during two periods of pedaling a bicycle ergometer at different levels of work output. Data are also included from similar studies carried out in five cardiac patients in whom no great vessel or intracardiac shunts could be demonstrated. The results showed a high degree of variability for the monochromatic earpiece densitometer values (standard deviation of differences: $\pm 31\%$) because of baseline variations due to changing conditions in the ear. The dichromatic earpiece densitometer which compensates for dynamic changes in the ear showed satisfactory comparison with arterial cuvette densitometer (standard deviation of differences: $\pm 14\%$). The dichromatic earpiece densitometer showed a linear relationship between its calibration factor for dye (centimeters deflection/milligrams dye/liter of blood) and the relative blood content of the ear. A dichromatic ear densitometer appears feasible for estimating cardiac output where use of more direct methods is precluded. It also appears possible by use of a previously calibrated ear-piece to obtain such values without the necessity of withdrawal and spectrophotometric analysis of blood samples for calibration.		

DD FORM 1 JAN 64 1473

UNCLASSIFIED
Security Classification

UNCLASSIFIED
Security Classification

14.	KEY WORDS	LINK A		LINK B		LINK C	
		ROLE	WT	ROLE	WT	ROLE	WT
	Indicated diluted dye Cardiac output Acceleration Oximeter earpiece						

INSTRUCTIONS

1. ORIGINATING ACTIVITY: Enter the name and address of the contractor, subcontractor, grantee, Department of Defense activity or other organization (*corporate author*) issuing the report.

2a. REPORT SECURITY CLASSIFICATION: Enter the overall security classification of the report. Indicate whether "Restricted Data" is included. Marking is to be in accordance with appropriate security regulations.

2b. GROUP: Automatic downgrading is specified in DoD Directive 5200.10 and Armed Forces Industrial Manual. Enter the group number. Also, when applicable, show that optional markings have been used for Group 3 and Group 4 as authorized.

3. REPORT TITLE: Enter the complete report title in all capital letters. Titles in all cases should be unclassified. If a meaningful title cannot be selected without classification, show title classification in all capitals in parenthesis immediately following the title.

4. DESCRIPTIVE NOTES: If appropriate, enter the type of report, e.g., interim, progress, summary, annual, or final. Give the inclusive dates when a specific reporting period is covered.

5. AUTHOR(S): Enter the name(s) of author(s) as shown on or in the report. Enter last name, first name, middle initial. If military, show rank and branch of service. The name of the principal author is an absolute minimum requirement.

6. REPORT DATE: Enter the date of the report as day, month, year; or month, year. If more than one date appears, on the report, use date of publication.

7a. TOTAL NUMBER OF PAGES: The total page count should follow normal pagination procedures, i.e., enter the number of pages containing information.

7b. NUMBER OF REFERENCES: Enter the total number of references cited in the report.

8a. CONTRACT OR GRANT NUMBER: If appropriate, enter the applicable number of the contract or grant under which the report was written.

8b, 8c, & 8d. PROJECT NUMBER: Enter the appropriate military department identification, such as project number, subproject number, system numbers, task number, etc.

9a. ORIGINATOR'S REPORT NUMBER(S): Enter the official report number by which the document will be identified and controlled by the originating activity. This number must be unique to this report.

9b. OTHER REPORT NUMBER(S): If the report has been assigned any other report numbers (*either by the originator or by the sponsor*), also enter this number(s).

10. AVAILABILITY/LIMITATION NOTICES: Enter any limitations on further dissemination of the report, other than those

imposed by security classification, using standard statements such as:

- (1) "Qualified requesters may obtain copies of this report from DDC."
- (2) "Foreign announcement and dissemination of this report by DDC is not authorized."
- (3) "U. S. Government agencies may obtain copies of this report directly from DDC. Other qualified DDC users shall request through _____."
- (4) "U. S. military agencies may obtain copies of this report directly from DDC. Other qualified users shall request through _____."
- (5) "All distribution of this report is controlled. Qualified DDC users shall request through _____."

If the report has been furnished to the Office of Technical Services, Department of Commerce, for sale to the public, indicate this fact and enter the price, if known.

- 11. SUPPLEMENTARY NOTES:** Use for additional explanatory notes.
- 12. SPONSORING MILITARY ACTIVITY:** Enter the name of the departmental project office or laboratory sponsoring (*paying for*) the research and development. Include address.
- 13. ABSTRACT:** Enter an abstract giving a brief and factual summary of the document indicative of the report, even though it may also appear elsewhere in the body of the technical report. If additional space is required, a continuation sheet shall be attached.

It is highly desirable that the abstract of classified reports be unclassified. Each paragraph of the abstract shall end with an indication of the military security classification of the information in the paragraph, represented as (TS), (S), (C), or (U)

There is no limitation on the length of the abstract. However, the suggested length is from 150 to 225 words.

14. KEY WORDS: Key words are technically meaningful terms or short phrases that characterize a report and may be used as index entries for cataloging the report. Key words must be selected so that no security classification is required. Identifiers, such as equipment model designation, trade name, military project code name, geographic location, may be used as key words but will be followed by an indication of technical context. The assignment of links, rules, and weights is optional.