

WADC TECHNICAL REPORT 54-323

PART 1

**THE EFFECT OF SURFACE FINISHES ON FRICTION AND
FUSION OF PARACHUTE CLOTH AND LINE**

VASILIS LAVRAKAS

ADOLPH KATZ

LOWELL TECHNOLOGICAL INSTITUTE

RESEARCH FOUNDATION

DECEMBER 1955

MATERIALS LABORATORY

CONTRACT No. AF 18(600)-136

PROJECT No. 7320

TASK No. 73201

WRIGHT AIR DEVELOPMENT CENTER
AIR RESEARCH AND DEVELOPMENT COMMAND
UNITED STATES AIR FORCE
WRIGHT-PATTERSON AIR FORCE BASE, OHIO

Carpenter Litho & Prtg. Co., Springfield, O.
500 - April 1956

Contrails

FOREWORD

This report was prepared by the Lowell Technological Institute Research Foundation under USAF Contract No. AF 18(600)-136. The contract was initiated under Project No. 7320, "Air Force Textile Materials", Task No 73201, "Textiles Materials for Parachutes", formerly RDO No. 612-12, "Textiles for High Speed Parachutes", and was administered under the direction of the Materials Laboratory, Directorate of Research, Wright Air Development Center, with Mr. Jack H. Ross acting as project engineer.

The author wishes to express his gratitude for the excellent cooperation of all the individuals and companies (See Appendix F) involved in our project. In particular, his sincere thanks are extended to the Project Engineer, Mr. Jack H. Ross of the Textiles Branch, Materials Laboratory, Directorate of Research, Wright-Patterson Air Force Base, Ohio; Mr. Adolph Katz and Mr. Basil G. Skalkeas of the Lowell Technological Institute Research Foundation staff; and Mr. Milton Boches and Mr. Harry Damas, graduate students of the Lowell Technological Institute, for their wholehearted aid in all phases of this program.

This report is the first of a series to be issued on a study of the effect of lubricants and fabric structure on the frictional and fusional properties of parachute cloth and line. The work performed in this report was divided into two phases. Phase I consisted of the designing of an apparatus and devising of a method for the rapid identification of effective lubricants in the prevention of "line burns". Phase II dealt with an investigation of the effects of heat, oxygen, and fungi on lubricated parachute materials. Other reports in this series will present basic work undertaken on the relationship of speed and fabric structure toward fusion and friction.

This report covers work conducted from March 1952 to March 1955.

An attempt to find lubricating agents which would minimize or prevent the fusion of nylon parachute materials caused by frictional heat was the main objective of this program. A friction apparatus, based on the belt friction principle, was developed to evaluate lubricating materials. Scoured parachute materials possessed high frictional forces and fused at low speeds and loads, while lubricated materials possessed lower frictional forces and fused at higher speeds and loads.

Many lubricants were examined and ten were classed as highly effective in preventing fusion. In addition, nylon parachute line coated with these best lubricants was further subjected to breaking strength, fungus resistance, and aging tests. No one lubricant was determined to be superior in all respects. It is recommended that a selection be made among several of those lubricants possessing the most desirable attribute, resistance to fusion, and subjecting them to drop tests at the indicated percentage pickup level.

PUBLICATION REVIEW

This report has been reviewed and is approved.

FOR THE COMMANDER:

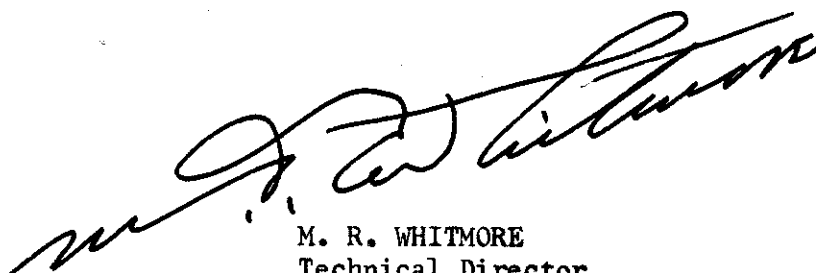

M. R. WHITMORE
Technical Director
Materials Laboratory
Directorate of Research

Contrails
TABLE OF CONTENTS

	<u>Page</u>
<u>PHASE I</u>	
AN EVALUATION OF THE FRICTION AND FUSION OF SCOURED AND LUBRICATED PARACHUTE MATERIALS.....	1
INTRODUCTION.....	1
INSTRUMENTATION.....	3
DESCRIPTION OF THE APPARATUS.....	4
METHOD OF TESTING.....	5
PARACHUTE MATERIALS AND LUBRICANTS USED.....	6
RESULTS AND DISCUSSION.....	7
<u>PHASE II</u>	
AN INVESTIGATION OF THE EFFECTS OF HEAT, OXYGEN, AND FUNGI ON PARACHUTE MATERIALS LUBRICATED WITH CLASS IV AGENTS.....	14
INTRODUCTION.....	14
A HEAT AND OXIDATIVE STUDY OF CLASS IV LUBRICANTS ON NYLON PARACHUTE MATERIALS.....	14
RESULTS AND DISCUSSION.....	15
SUMMARY OF RESULTS.....	18
BIBLIOGRAPHY.....	19
EXPLANATION OF SYMBOLS USED IN THE TABLES AND FIGURES.....	21
APPENDIX A.....	87
APPENDIX B.....	103
APPENDIX C.....	109
APPENDIX D.....	130

Continued
TABLE OF CONTENTS - continued

	<u>Page</u>
APPENDIX E.....	132
APPENDIX F.....	137
APPENDIX G.....	139

Continents
LIST OF ILLUSTRATIONS

<u>Figure No.</u>		<u>Page</u>
1	LINE BURN ON A PARACHUTE FABRIC.....	22
2	LINE BURN ON A PARACHUTE FABRIC PRODUCED BY THE LTIRF FRICTION APPARATUS.....	23
3	FUSION DAMAGE TO PARACHUTE SHROUD LINE PRODUCED BY LTIRF FRICTION APPARATUS.....	24
4	DIAGRAM OF HIGH SPEED FRICTION APPARATUS.....	25
5	LTIRF HIGH SPEED FRICTION APPARATUS.....	26
6	IDEALIZED SAMPLE CURVE FROM RECORDER WITHOUT FUSION OCCURRING.....	27
7	IDEALIZED SAMPLE CURVE FROM RECORDER WITH FUSION OCCURRING.....	27
8	THE EFFECT OF RELATIVE HUMIDITY UPON MAXIMUM AND MINIMUM TIGHT TENSION.....	28
9	THE EFFECT OF SLACK TENSION UPON TIGHT TENSION AND THE COEFFICIENT OF KINETIC FRICTION USING SCOURED CLOTH AND LINE	29
10	THE EFFECT OF SLACK TENSION ON THE TIGHT TENSION WITH VARYING ANGLE OF WRAP USING SCOURED CLOTH AND LINE.....	30
11	A COMPARISON OF THE EFFECT OF NORMAL AND BIASED CUTTING OF CLOTH ON TIGHT TENSION.....	31
12	THE EFFECT OF SLACK TENSION UPON TIGHT TENSION USING UNSCOURED CLOTH (SPINNING OILS PRESENT) AND LINE.....	32
13	THE EFFECT OF SLACK TENSION ON TIGHT TENSION AND THE COEFFICIENT OF SLIDING FRICTION USING CLOTH (SPINNING OILS AND CORONYL PRESENT) AND LINE AS RECEIVED FROM THE MANUFACTURER.....	33
14	THE EFFECT OF SLACK TENSION AND SPEED ON KINETIC FRICTIONAL FORCE USING CLOTH (CONTAINS CORONYL) AS RECEIVED FROM THE MANUFACTURER.....	34
15	THE EFFECT OF LUBRICATION ON SPEED AND FUSION LOAD.....	35

Contrails
LIST OF TABLES

<u>Table No.</u>		<u>Page</u>
1	THE EVALUATION OF LUBRICANTS IN THE PREVENTION OF THE FUSION OF PARACHUTE MATERIALS.....	36
2	CLASS IV LUBRICANTS.....	61
3	SOME PHYSICAL CHARACTERISTICS (ADHESION AND FLEXIBILITY) OF LUBRICANTS ON PARACHUTE SHROUDLINE.....	64
4	THE RESISTANCE TO FUSION OF SILICONE TREATED AND UNTREATED TWILL CLOTH AND SCOURED LINE.....	73
5	A COMPARISON OF THE DATA OBTAINED FROM LUBRICATING BOTH LINE AND CLOTH, AND LUBRICATING THE LINE ONLY.....	74
6	A COMPARISON OF DATA OBTAINED FROM RUBBING LUBRICATED CLOTH VS. SCOURED LINE, AND LUBRICATED LINE VS. SCOURED CLOTH.....	75
7	THE EFFECT OF HEAT-OXIDATIVE TREATMENT AT 225°F FOR 24 HOURS ON THE CLASSIFICATION OF CLASS IV LUBRICANTS.....	76
8	A LIST OF THE BEST LUBRICANTS AFTER HEAT-OXIDATIVE TREATMENT	78
9	THE EFFECT OF HEAT-OXIDATIVE TREATMENT AT 350°F FOR ONE HOUR UPON THE CLASSIFICATION OF A LUBRICANT.....	79
10	THE EFFECT OF CLASS IV LUBRICANTS AND OF HEAT-OXIDATIVE TREATMENT AT 225°F FOR 24 HOURS UPON THE BREAKING STRENGTH-ELONGATION OF NYLON SHROUD LINE.....	80
11	THE EFFECT OF EXPOSURE FOR ONE HOUR AT 350°F ON THE PERCENTAGE PICKUP, BREAKING STRENGTH, AND ELONGATION OF LUBRICATED SHROUD LINE.....	81
12	THE EFFECT OF FUNGUS GROWTH ON AGED AND UNAGED LINES AS MEASURED BY FUSION AND BREAKING STRENGTH TESTS.....	82
13	THE EFFECT OF AGING FOR 24 HOURS AT 225°F ON THE CLASSIFICATION OF LUBRICANTS.....	83
14	THE EFFECT OF AGING FOR 24 HOURS AT 225°F ON THE BREAKING STRENGTH OF NYLON PARACHUTE LINE.....	84

Centrair
LIST OF TABLES - continued

<u>Table No.</u>		<u>Page</u>
15	THE EFFECT OF FUNGUS GROWTH ON THE CLASSIFICATION OF UNAGED LUBRICANTS.....	85
16	THE EFFECT OF FUNGUS GROWTH ON THE CLASSIFICATION OF AGED LUBRICANTS.....	86

AN EVALUATION OF THE FRICTION AND FUSION
OF SCOURED AND LUBRICATED PARACHUTE MATERIALS

INTRODUCTION

The present study of the friction and fusion of parachute materials has been motivated by an interest on the part of the United States Air Force to minimize or prevent the so-called "line burns" which appear upon the canopy cloth of a parachute during a jump. Whenever line burns occur, a strong possibility exists that the panels of the parachute may tear.

The United States Air Force believes that two major causes exist for the appearance of line burns.

1. Friction of the nylon shroud line on the holding loop when the shroud line is pulled from the deployment bag.
2. Inversion or partial inversion of the parachute.

The ejection of the shroud line from the deployment bag involves a relative speed between the two nylon surfaces of approximately 60 ft/sec; while inversion involves a relative speed of approximately 140 ft/sec. These figures are merely estimates of the United States Air Force as no accurate data are known at the present time.

Under these functional conditions of rubbing, the relatively low melting point of nylon (482°F) may be reached as a result of frictional heat, leading in many instances to tearing of the fabric. Figure 1 shows an example of a line burn on a nylon parachute fabric.

Since frictional heat can be lowered by reducing the coefficient of sliding friction, the use of lubricants as a possible remedial measure becomes apparent. In addition, by interposing between the two rubbing surfaces a sufficiently thick layer of a lubricating agent of low coefficient of thermal conductivity, as many lubricants possess, the possibility of the melting point of nylon being reached may be further reduced.

Other possible methods of reducing the damage to nylon have been considered:

1. The use of parachutes under less severe frictional conditions.
2. The use of fibers in parachute construction with higher melting points than nylon.
3. Variation in fabric structure to reduce or minimize friction.

Contrails

It is obvious that the first method is not practicable, as the trend in parachute operation has been in the opposite direction. The second and third are both practical and promising. The use of fibers other than nylon will also affect the dynamic operating characteristics of the parachute and, therefore, will require a great amount of research. Insofar as fabric structure is concerned, a definite effect upon the occurrence of line burns may result if such parameters as cloth weight, thickness, and yarn twist are varied. A study of fabric structure* is part of this program and a basic investigation has been undertaken to investigate the effect of fabric structure upon frictional forces and the appearance of fusion.

Previous attempts have been made to solve the problem of parachute line burns.

In 1945 E. I. du Pont de Nemours Company investigated line burns using lubrication of the parachute cord as their basic approach to the problem.

Of some 150 lubricants tested, Opal Wax was selected as the best (Appendix A). Opal Wax was then applied to parachute shroud lines and a field trial performed at Fort Bragg.** Unlubricated lines were tested as controls.

The results indicated inconclusively that lubricated parachutes were less likely to cause line burns than those which were unlubricated.

Other work on the elimination of line burns was done in 1950 at the Naval Air Factory, Philadelphia, Pa. Both line and fabric of the parachutes were treated with Opal Wax and then drop tested. Inconclusive data were obtained which indicated a possible reduction of line burns.

From a study of both theoretical and experimental work*** which has been reported in the literature, little information is available for use in a solution of our unique problem. Such factors as high molecular weight and type of surface active agent are of importance in lubrication; but to determine whether or not these are the only factors entering into this phenomenon is difficult. Consequently, it was necessary to investigate many types of lubricants. An instrumental approach to the problem of measuring frictional forces was designed. This approach also identified the point of fusion which served as an adequate end-point of the effectiveness of a lubricant.

* WADC TR 54-570

** In Appendix B material from the Army report is presented in greater detail.

*** See Appendix C for a detailed survey of this study.

Several theoretical and experimental methods exist for the determination of the effect of various parameters, such as surface condition, lubricants, and temperature upon the friction between two sliding surfaces.

In certain specialized cases (mainly in metallic studies), reliable theoretical formulations are available. These, however, are quite complex in nature and require precise data concerning all the factors affecting friction.

Friction may also be studied under actual operating conditions. This would generally be considered the most reliable procedure, but in the particular case of shroud line burns on a parachute canopy, this procedure is both costly and hazardous.

However, the factors affecting friction can be readily controlled and evaluated on a laboratory basis. Suitable apparatus may be devised for such a study, and the results extrapolated to fit into the actual application. The true value of the laboratory study is finally determined by applying the results obtained to the actual end use conditions.

Two basic techniques are used in the study of friction: the first technique employs the motion between the sliding surfaces in a single plane as is the case in an inclined plane apparatus. The second technique utilizes the slipping of one material over a rotating cylinder having an appropriate covering on its surface. This second technique, called the belt friction apparatus, has been extensively used by many investigators in fiber research and is most applicable to textiles.

At the beginning of our project an apparatus was designed to simulate as closely as possible the conditions encountered in a parachute jump, which produced the phenomenon of fusion and resultant tearing of the nylon canopy cloth. This apparatus consisted of length of cord wrapped around a wheel. The wheel, at high speed, was allowed to come into contact with a piece of parachute cloth. The cloth was ballooned by means of air pressure. It was thought that as the spinning wheel and ballooned cloth came into contact fusion should occur. Such an apparatus, nevertheless, proved unsuccessful as the parachute cloth did not fuse, for neither the speed nor the load obtainable was great enough to cause fusion. The second drawback to this apparatus was the absence of a convenient method of measuring the frictional forces involved.

Upon further consideration, it was felt that a duplication of the real mechanical conditions producing line burns was not absolutely necessary. It is true, in the case of the actual parachute, that the area of contact would depend upon the depression made by the shroud line into the opened parachute. However, the character of the frictional phenomena should remain constant as long as the shroud line was sliding across the surface of the fabric. Hence, why would it not

Contrails

be practicable to simply bring the shroud line into a sliding contact with the fabric, and have the fabric supported on a solid surface? Furthermore, would not a lubricant which effectively reduced the friction between the shroud line and parachute on such an apparatus have a positive effect in reducing the friction in the operation of the actual parachute?

As a consequence of this reasoning, a machine utilizing the belt friction principle was designed by Prof. Edward Sabbagh of the Lowell Technological Institute faculty. By means of this apparatus the fusion of sliding parachute fabrics was easily produced. In addition, from a knowledge of tensions and angle of wrap, experimental data on the frictional forces involved were also obtainable.

In Figure 2 the damage produced to nylon cloth by the belt friction apparatus can be seen; the melted nylon of the cloth, which appears along the edges of the openings in the nylon, contrasts greatly with the appearance of the normal state of the parachute fabric and approximates the appearance of the fused sections of the damaged parachute samples presented in Figure 1.

The damage to the parachute line produced in the laboratory is shown in Figure 3 and is typical of the damage (i.e., a thick piece of nylon has fused to the test line) resulting whenever fusion occurs. In some respects it is similar to the damage caused to the actual line. However, other sections of the actual damaged line appear to have only a thin surface layer of the nylon fused to it, almost as if the nylon had vaporized and condensed on the line. This condition may be caused by the line running at extremely high speeds and low loads so that in a short time interval of contact only the surface nylon is fused.

DESCRIPTION OF THE APPARATUS

The apparatus (Figures 4 and 5) consisted of a cast iron pulley, A, five inches in diameter and two and one-half inches in width, with a slit cut across its width to accommodate the test fabric. A strip of parachute cloth is wrapped tightly around the pulley. The ends of the fabric are fastened securely to the underside of the pulley with masking tape. The shroud line, F, is attached to the strain gauge, B, drawn around the pulley, C, and wrapped around the pulley, A, to produce an angle of wrap of 360°. (The line may also be set up to produce an angle of wrap of 90°, 180°, or 270°.) The shroud line then passes over the pulley, D, and a weight, W, is suspended from the end of the line. The pulley, A, can be driven at peripheral linear speeds of 25, 36, 52, and 75 ft/sec (± 1 ft/sec) by means of a multiple pulley arrangement. The output of the strain gauge, B, is fed through an amplifier, and recorded on a Brown "Electronik" potentiometer strip chart recorder. From this chart the sliding frictional force at any given time may be found.

As the line has a tendency in some instances to flutter on top of the pulley, a simple holding device was constructed to prevent this action. A saddle-shaped piece of steel, E, was attached to the apparatus by means of a rod and

Contrails

frame. This holding piece just clears the shroud line and pulley, but is sufficiently close to the line to prevent excessive "fluttering."

METHOD OF TESTING

The sample of cloth is wrapped around the pulley. The parachute cord is then wrapped over the cloth for the desired angle of contact. Slack tensions on the same sample are progressively increased, after a running time of 1.5 minutes, until fusion finally occurs. The fusing of the parachute materials is detected by an instantaneous increase in frictional force registered on the recorder, as well as by the ripping of the cloth (see Figures 6 and 7). The slack tension at time of fusion is used as an end-point for the attainment of fusion and is referred to as the fusion load, FL , in grams. Once fusion has occurred, a new sample of cord and cloth are used for further testing. Atmospheric conditions of 65% R. H. and 70° F were used for all tests.

In the testing of lubricants, lengths of cord are dipped simultaneously into a solution of lubricant. The percentage pickup of lubricant on a length of cord is calculated by a determination of the conditioned weight of the line before and after dipping. Generally, unless otherwise indicated, the lubricated line is tested against scoured cloth.

The experimental data obtained from the apparatus are utilized in the belt friction formula,

$$\frac{T_2}{T_1} = e^{\mu_k \theta}$$

from which the coefficient of kinetic friction, μ_k , can be calculated. The tight tension, T_2 , occurring at sliding, is found from the minimum force** on the recorder, minus the weight of the line from the pulley, C , to the strain gauge. The slack tension, T_1 , is found by adding to the attached weight, W , the weight of the line from the pulley, D , to the attached weight. The angle of contact or wrap, θ , was determined by a protractor, and e is the base of the Napierian logarithm 2.718....

In the case of the unlubricated samples, to overcome the possible factor of the creep properties of the materials, each set of samples was allowed to stand mounted for twenty seconds before the test was run. The pulley was started and allowed to run for two minutes. Later on, in the final testing of lubricants,

* See Appendix D for the complete derivation of the formula.

** See Appendix E for a discussion of the types of curves obtained.

Contrails

a time interval of 1.5 minutes was used as it was felt that this period of time allowed the system sufficient time to reach steady state conditions. Still later, a further modification was also made in overcoming the creep properties of the materials. Instead of allowing twenty seconds to pass, the shaft (G) was given a slight twist which rotated the pulley (A) until the shroud line just started to slip over the nylon canopy fabric wrapped around pulley (A). This was repeated three or four times. The force registered just at the moment of slippage is the force associated with static friction. Data on static frictional force were obtained as a result of this procedure.

PARACHUTE MATERIALS AND LUBRICANTS USED

The materials (unless otherwise noted) used on all tests were:

1. Nylon suspension line, Specification MIL-C 5040, Type III, natural.
2. Nylon canopy cloth, Specification MIL-C-7020, Type I, (1.1 ounces per square yard, ripstop, natural).

Statistical sampling of the nylon cloth and line, insofar as frictional forces and fusion were concerned, showed that no significant difference existed between the sections of the cloth as well as the line. Therefore, in all the following work the line and cloth were used as needed without employing special precautions in selecting samples. It was also felt that because the parachute cloth and line are held to very close tolerances in their manufacture and, to avoid delay, it would not be necessary to sample continually all lots of line and cloth that were used. Actually, the cloth received when the main part of our program began was used throughout.

At the beginning of our program no data were available on the dependence of the fusion of a lubricated nylon surface upon the properties of a lubricant (e.g., coefficient of sliding friction or viscosity). Therefore, it was necessary to test as many compounds as possible.

Chemical concerns (Appendix F) were contacted to obtain possible lubricants. Specific compounds were requested as well as ones suggested by the manufacturer.

It should be strongly emphasized that no concern supplying compounds for this project represented them as being effective agents for preventing the friction-fusion of nylon. Our test results therefore should not be misconstrued in terms of the recommended uses of these products, but should only be considered in relation to our unique problem.

Specimen Preparation

Parachute cloth and line were scoured by the method usually employed in such work. The parachute cloth was generally used in a scoured condition. The parachute lines were simultaneously dipped for ten minutes* into a solution of lubricant, hung to dry from a bar, and then transferred to a conditioning room. Precautions were taken to avoid excessive handling and contact of the lines.

RESULTS AND DISCUSSION

To commence our program of parachute lubrication, the following points were investigated:

1. The effects of relative humidity on tight tension, frictional force, and the sliding coefficient of friction.
2. A study of the frictional forces and fusion effects of scoured and unscoured parachute materials.

As a consequence of the first investigation, basic information would be made available for a better understanding of the conditions needed to study parachute friction. A study of the second point would be of value in establishing data in regard to friction and fusion of scoured and slightly finished parachute materials. These data would also serve as a control for future work with higher amounts of lubricants present. Consequently, in the following sections results are presented of the effects of relative humidity and the amount of finish upon fusion and friction.

Effect of Relative Humidity on Tight Tension and the Coefficient of Sliding Friction

One of our first studies was made on the relationship between relative humidity and tight tension at 17 ft/sec. At initial time and at constant slack tension, a maximum point was always observed for tight tension, which decreased to a minimum after 2.0 minutes. The data for minimum and maximum tight tension values are plotted in Figure 8.

In Figure 8 the plotted values of maximum tight tension are higher by a significant amount than those at minimum tight tension. As the relative humidity increases, the values for maximum slack tension increase (μ_k increases from 0.17 to 0.20), while those for minimum slack tension stay essentially constant ($\mu_k = 0.16$).

* See Appendix G for details in regard to the establishment of the time of immersion.

Contrails

These two curves and their differences may be explained by assuming that frictional heat causes the fabric surface to dry, and that the frictional forces of the drier surface are less than that of the surface with the greater moisture content. Hence, after a time interval of two minutes, regardless of ambient R. H., the fabric surfaces have become the same in moisture content and therefore have the same frictional value.

A Study of the Frictional Forces and Fusion Effects of Scoured and Lubricated Parachute Material

To establish a basis for comparison with lubricated materials, as well as to determine friction forces and fusion effects, one of the initial investigations was directed toward a study of scoured line and cloth.^{*} The method employed was to run the line always parallel to the warp yarns. This was a standard procedure used throughout our program, unless otherwise noted.

The data obtained are plotted in Figure 9. It is observed that the coefficient of kinetic friction rises to a relatively high value at speeds of 24 and 35 ft/sec and at an angle of wrap of 90° as the slack tension is increased. At 24 ft/sec it is possible to obtain a maximum slack tension, T_1 , i.e., fusion load, FL, of 43 grams before fusion results, although some marks of abrasion appear at lower slack tensions at the rip stop sections of the cloth. This abrasion, without doubt, affects the forces of friction registered on the recorder. It was also noted that an angle of wrap of 360° could not be used as fusion and tearing immediately resulted. However, an angle of wrap of 270° was tested (Figure 10) and results showed that the fusion load was only 23 grams. Finally, an angle of wrap of 90° was used as it would allow a sufficient number of measurements to be made. At a speed of 35 ft/sec, the fusion load was 23 grams. At this tension, some samples fused and abraded noticeably after only a few seconds of running.

Scoured cloth, cut on a 45° bias, was tested against scoured line. This was done to determine whether or not the angle of contact of rubbing of the shroud line in relation to the cloth warp yarns is significant in the frictional process. The results of the determinations are given in Figure 11.

At 24 ft/sec the cloth cut parallel to the warp yarns appears to have higher value for tight tension. However, at 35 ft/sec a reversal of this occurs; i.e., cloth cut on a 45° bias has higher values. The difference in value of tight tension is probably not significant, as experimental error may be sufficiently great to produce these differences, as well as the anomalous shift in tight tension in the change from 24 to 35 ft/sec.

* The percentage of material extractable in ether from the canopy cloth was 0.009 and from the line was 0.01. The average breaking strength of the unscoured fabric was 45.4 lbs, of the scoured fabric 45.9 lbs.

Unscoured cloth* and line as received from the manufacturer were tested against unscoured line (Figure 12). Since a slight amount of surface finish** was present, it was possible to use an angle of wrap of 360° rather than the 90° angle of wrap which was used with the scoured material. The slack tension reached was also higher (approximately 2.4 times that of the scoured cloth and line). The speed was 24 ft/sec; unfortunately, it was not possible to run at higher speeds since the available supply of material was inadequate. The coefficient of sliding friction, it was found, stays essentially constant. However, the results again indicate the general trend; lubrication of the parachute materials allows more severe conditions to be withstood by the materials even though a small quantity of lubricant is present on the sliding surfaces.

The data on cloth and line*** as received from the manufacturer are given in Figure 13 of this report. The results indicate that with the anti-tear agent**** present on the cloth, in addition to the spinning oils on cloth and line, a still higher range of slack tension and speed can be reached before the onset of fusion. For example, at 24 ft/sec, the fusion load, FL, is 153 grams (in contrast to the cloth without the anti-tear agent, where FL reaches only 102 grams); at 35 ft/sec, the fusion load is 103 grams and at 52 ft/sec it attains a value of 33 grams. There is a marked trend toward reaching higher speeds and slack tensions if an appreciable amount of lubricant is on the cloth and line.

Figure 14 indicates that at lower slack tensions the kinetic frictional force does not vary appreciably with the speed. Only at the higher loads does there seem to be a slight difference between frictional forces.

From results obtained in this program, and summarized broadly in Figure 15, the effect of increasing surface finish is to increase the ability of the nylon materials to resist fusion at low speeds and slack tensions and, therefore, to permit a higher speed and load to be withstood by the nylon. In addition, data obtained indicated that for scoured materials the angle of wrap which could be used was 90° at a speed of 35 ft/sec with a fusion load of 23 grams. Any attempt to increase the angle of wrap to higher values resulted in immediate fusion. However, if the material was not scoured but used as it was received from the manufacturer, the angle of wrap before fusion was increased to higher values. Thus, the application of a lubricant prevents fusion of the nylon within certain limits of speed and load, and fusion occurs only when the speed and load or both become excessive.

* No Coronyl present.

** Percentage of material extractable in ether from the canopy cloth was 0.70 and from the line was 0.44.

*** Per cent extractables in chloroform of line was 0.60, and of cloth was 0.62.

**** Coronyl.

A Study of Parachute Lubricants

As preliminary results indicated, fusion was prevented by the presence of a surface finish; an investigation was begun to evaluate lubricants which, when applied to parachute materials, would prevent or minimize the fusion of nylon at high loads and speeds.

The method of lubrication employed in this investigation has been of necessity based on the concept that in order to quickly screen a large number of lubricants, a procedure as simple and effective as possible would have to be followed. It was soon determined that rapid and trustworthy results would be obtained by lubricating two samples of scoured shroud line and running the line against scoured cloth. This method would be most likely followed in practice as the effect of an excess of lubricant upon the canopy cloth might be to decrease its permeability to dangerously low levels.

The Separation of Lubricants into Classes

Effective and ineffective lubricants in our investigation can be separated by assuming that the ability of a lubricant in preventing fusion is measured through the use of slack tensions at the highest speed (75 ft/sec) attainable on our friction tester and at an angle of wrap (360°). Those that are classed as ineffective generally fail to prevent fusion at a slack tension of 52 grams or less; while those that are classed as effective lubricants support higher slack tensions. Four main classes have been established using as a foundation for these classes the following arbitrary criteria:

Class I

Lubricants which do not prevent the fusion of nylon at a slack tension of 52 grams, a velocity of 75 ft/sec, and an angle of wrap of 360° within a time interval of 1.5 minutes.

Class II

The experimental conditions of velocity and angle of wrap are the same as in Class I; the slack tension is increased to 102 grams.

Class III

The experimental conditions of velocity and angle of wrap are the same as in Class I; the slack tension is increased to 152 grams.

Class IV

The experimental conditions of velocity and angle of wrap are the same as in Class I; the slack tension is greater than 152 grams (generally at 202 grams).

Table 1 contains all the lubricants investigated and the classes into

Contrails

which they fall. This table also shows the effect of increasing percentage pickup on the classification of the finish or lubricant.

A total of 229 lubricants were tested and evaluated for their effectiveness in preventing fusion by the following procedure.

Class I lubricants are considered to be valueless in the prevention of fusion at high speeds. Class II, III, and IV are progressively better lubricants and are of value; however, Class IV lubricants, as they bear higher slack (ca. 202 gm) and tight tensions (ca. 420 gm), obviously offer the best protection against the fusion of nylon. These Class IV lubricants therefore have been studied further in preference to the other two classes.

At the 10 percentage pickup level, the maximum allowed by the United States Air Force, only 27 lubricants are in Class IV. Table 2 contains the names, percentage pickup, and chemical nature, if known, of these lubricants.

Before any Class IV finishes can be used in practice, data must be accumulated on heat and oxidative stability in the presence of atmospheric oxygen at 225° and 350° F. Results on heat and oxidative stability are presented in another section of this report. These temperatures may be encountered by the lubricant when placed on nylon and Dacron parachutes, respectively.

Table 1 also contains data indicating the effect of increasing percentage pickup upon the fusion-preventing qualities of the lubricant. Increasing percentage pickup often causes a material to increase its effectiveness in preventing fusion and thus the material advances to a better class. This is not always true as illustrated by such compounds as Monopol Oil 48 and Prestabit Oil V; although their percentage pickups are increased greatly, these materials remain in the same class (Class I).

In several cases the maximum percentage pickup was not obtainable, though high solution concentrations (80-100% by weight) were used. Because of the lack of time, further attempts to increase the percentage pickup to higher values were not performed. Other lubricants, which imparted to the line poor characteristics of adhesion or flexibility, also were not examined further.

Adhesion and flexibility were determined only qualitatively (Table 3). If the lubricant was a solid and flaked off as the line was flexed then it would be classed as poor. If the lubricant was a liquid, then it was categorically classed as satisfactory. The flexibility of the line was also determined qualitatively by flexing; if the line was limp and flexed easily, then the lubricant was classed as satisfactory; if, on the other hand, the line was stiff and flexed with difficulty, the lubricant was classed as poor.

Lastly, as many as possible of the lubricants were tested in pairs. However, toward the close of this phase of the program, because of limited time, only one sample was tested and is indicated in Table 1 by means of the parenthetical superscript above the percentage pickup.

The Fusional Testing of 0.9 and 1.6 oz Silicone Treated Twill Cloth

An Air Force program to evaluate formulations of silicone oil (Dow Corning Silicone Emulsion XE-112A) as a finishing material for parachute cloth which was performed by Cheney Bros., Connecticut, under Air Force Contract No. AF 33(038) 21866 had been completed (20). It was thought worthwhile to investigate the fusional characteristics of these materials to obtain some prior knowledge of the resistance to fusion of silicone treated cloth before field tests were run. Our testing procedure and results may eventually be further validated by comparison to the actual results in the field.

Samples of the materials were sent by the Wright Air Development Center to be tested for their resistance to fusion upon our friction and fusion tester. These samples consisted of the following materials:

1. Untreated twill cloth, 1.6 oz.
2. Silicone treated twill cloth, 1.6 oz.
3. Silicone treated twill cloth, 0.9 oz.

Five samples were cut, equally spaced, from selvage to selvage over the entire length of cloth in such a way as to obtain a random sampling of the cloth. Each sample was identified to indicate the location from which it had been obtained.

The samples were conditioned at 65% RH and 70° F for approximately twenty-four hours. Preliminary tests, run at a linear speed of 75 ft/sec and an angle of wrap of 360° indicated that, at a slack tension, T_1 , of 22 grams, the samples of silicone treated cloth did not fuse during the running time of approximately two minutes, while the untreated 1.6 oz cloth fused immediately. Therefore, a more careful determination of the slack tensions withstood by the fabric for 1.5 minutes was carried out upon each group of five samples. The experimental results are reported in Table. 4.

The results of these tests indicate that the silicone oil finish improves the fusion resistance of each fabric. The two treated samples appear to be slightly different in their ability to withstand fusion. The 0.9 oz twill cloth has an average fusion load of 38 gm, while the 1.6 oz cloth has a fusion load of 22 gm. This difference in fusion load probably results from the fact that the thicker (1.6 oz/sq yd) material retains the heat of friction to a greater extent than the lighter (0.9 oz/sq yd) twill. However, it should be realized that the difference is of a low order of magnitude, and that other considerations, such as resistance to tearing, may make the heavier material preferable in parachute construction. In addition, if higher speeds of rubbing are encountered, as may be the case in the actual operation of the chute, neither of the two materials would prove effective. The observation was made, for all cases studied, that frictional force tended to increase during each test. This may be caused by the possibility that insufficient silicone oil was present permitting a more intimate contact of line and cloth.

The effects of G. E. silicone oils, such as Fluids C, D, E, F and H (applied at the Lowell Technological Institute Research Foundation) have been reported in another section. The per cent pickup of silicone oils by scoured line was 15-20%, and the lubricated line was run against scoured ripstop material. Almost all of these agents were able to support a slack tension of 102 grams without fusion taking place. The treated twill cloth submitted for testing by Wright Air Development Center, however, contained approximately 0.5% extractables (20). It would, therefore, appear that the oil present upon the cloth was insufficient to achieve the maximum benefit from this oil as a parachute lubricating agent.

Consequently, in order to observe the effects of adding a higher percentage pickup of lubricant to the cloth, G. E. Silicone Oil **Fluid E** was added to two samples of each twill cloth at approximately the same percentage pickup for all samples. The results indicated a definite improvement occurred to an approximate maximum slack tension of 100 grams. As time was not available, it was not possible to lubricate both line and twill cloth. On the basis of other results, an improvement towards resistance to fusion should appear if this were done.

Some Results Concerning the Effect of Lubricating Both Line and Cloth, and Cloth Only

Both line and cloth were lubricated in order to compare the results of what is effectively the interposition of a greater thickness of lubricant between the two sliding fabric surfaces. Cosmol 1000, one of the better lubricants, and Fluorolube HO, a poor lubricant, were applied to the line and cloth. The results are averages of two tests on each lubricant and are shown in Table 5. For comparison, the results of tests on lubricated line and scoured cloth are also included.

These results appear to indicate that a slight increase in the case of both poor and good lubricants is effected if both rubbing surfaces are lubricated. The increase, it is believed, is not of a significant nature from the standpoint of an increase in slack tension, but in actual usage may be sufficiently significant to indicate that all potential rubbing surfaces should be adequately lubricated.

Several Class IV lubricants were tested to observe the effect of lubricating cloth only. The results are presented in Table 6; for comparison, the results obtained for lubricated line - scoured cloth are also presented.

The general trend observed is that somewhat of a lowering, although not a highly significant one, has occurred. Consequently, to achieve the maximum benefit from a lubricant both line and cloth ought to be lubricated, with a relatively high amount being placed on the line.

AN INVESTIGATION OF THE EFFECTS OF HEAT, OXYGEN,
AND FUNGI ON PARACHUTE MATERIALS LUBRICATED WITH CLASS IV AGENTS

INTRODUCTION

Class IV lubricants may be expected to encounter occasionally while in storage temperatures from 225° F to 350° F. Tests, therefore, were performed to determine the heat and oxidative stability of these lubricants, as well as their effect upon the strength of the nylon.

In addition, although nylon itself is resistant to mildew damage, the action of fungi and bacteria on lubricated parachute materials must also be investigated.

Class IV lubricants were therefore subjected as a final part of our testing program to fungus resistance tests by the Biochemical Section, Protective Processes Branch, Materials Laboratory, Wright Air Development Center. On the basis of these and other tests lubricants may be selected with a good degree of certainty which will operate most efficiently in their end use.

A HEAT AND OXIDATIVE STUDY OF
CLASS IV LUBRICANTS ON NYLON PARACHUTE MATERIALS

Experimental and Sample Preparation Procedure

A procedure was devised by which a separation of lubricants was possible in a twenty-four-hour interval at 225° F and a one-hour interval at 350° F, using an air circulating oven with an air flow over the sample of 250 ft/min. Four one-yard samples were used to determine percentage pickup by being placed uniformly throughout the bath when the main length of fourteen yards was dipped. Two of these four one-yard samples were used to determine percentage pickup before, and two after heat treatment. These values were then taken as representative of the values of the fourteen-yard length of line. In this manner, the time-consuming problem of determining the percentage pickup of a long length of cord and pieces cut from it was avoided.

The procedure used is contained in the following table:

<u>Number of Samples</u>	<u>Length of Each Sample (yd.)</u>	<u>Treatment of Lub. Sample</u>	<u>Test</u>
2	2	Not Exposed to 225° F (Control)	Fusion
3	1	" " " " " "	Breaking Strength
2	2	Exposed to 225° F for 1 Hour	Fusion
3	1	" " " " " "	Breaking Strength

From this procedure resistance to fusion after heat treatment was determined. Any deleterious effect of the lubricant before and after the heat treatment was found by breaking strength tests.

RESULTS AND DISCUSSION

The data presented in Table 8 show that only ten lubricants (taken from Table 7) out of twenty-six are resistant to the effects of heat and oxygen. The criterion used for selecting these ten lubricants is the following: if the lubricant fell to Class I after heat treatment, then regardless of percentage pickup present, the lubricant was considered of little value in the prevention of fusion and was not studied further.

It will be noted in Table 7 that many samples prior to heat treatment are not in Class IV even though previous tests had indicated they were. The cause or causes of this anomalous behavior probably are:

1. Percentage pickup used was lower than previously used. (e.g. Spermafol 45, Table 5, 11.1%, Class IV; and in Table 6, 10.0%, Class III-IV)
2. This work was done by several persons. It may reflect then a difference in technique of each person.
3. A lack of exactness in our testing procedure and instrument.
4. Finally, these results may be caused by the so-called inherent variability of textile materials and of commercial compounds.

In addition, the characteristics of flexibility and adhesion after exposure to 225° F for twenty-four hours, percentage pickup, and class, both before and after heat treatment, of these best ten fusion-preventing agents are included in Table 8. The only lubricant which appears to be somewhat poor from the standpoint of flexibility is Methacrol Lub K. However, as the test used to determine flexibility is highly subjective, this lubricant, being satisfactory in all other respects, was tested further with the others. A list of these compounds follows:

Alkaterge C
Ceresine-White-Ozokerite
Glaurin
Liquid Cosmol
Methacrol Lub K
Myvacet 5-00
Myvacet 9-40
Spermafol 45
Sperm Oil (NW) 45
Spermaceti

Contrails

In addition to exposure to 225° F, all lubricants from Table 8 have been exposed to 350° F for one hour and tested for loss in class and percentage pickup. The results are presented in Table 9. On the basis of the results of treatment at 350° F, the following lubricants are considered to be satisfactory in resistance to heat and oxygen:

Alkaterge C
Ceresine-White-Ozokerite
Glaurin
Liquid Cosmol
Spermaceti
Spermafol 45
Sperm Oil (NW) 45

Of these lubricants the most effective in preventing fusion of nylon is Spermafol 45, as it is in Class IV and only falls to Class III after exposure for one hour to 350° F.

The Effect of Lubricants on Heat-Treated Nylon as Measured by Breaking Strength and Elongation Tests

To find the effect of applied lubricant on nylon cord, lubricated line both before and after exposure to 225° F for 24 hours was subjected to breaking strength-elongation tests. Using this test the effect of the lubricant upon nylon was found.

The breaking strength-elongation data based on the average of three tests per sample of lubricant, are tabulated in Table 10. No lubricants, before and after heat treatment, improved the breaking strength-elongation properties of nylon cord. On the contrary, most lubricants decreased this property significantly before the heat treatment. None, however, decreased the breaking strength below the limit (550 lbs) specified in MIL-C-5040. After exposure to 225° F for 24 hours all lubricated lines, except Myvacet 5-00 and Alkaterge C, had values below the required breaking strength. It is also observed that scoured nylon line after heat treatment maintains a value (573 lbs) above that required in MIL-C-5040.

These lubricants were further subjected to a temperature of 350° F for one hour (Table 11). If the breaking strength of scoured nylon at 350° F is used as a basis for separating lubricants, some lubricants which were unsatisfactory at the lower temperature have become satisfactory, and in fact improved the resistance of nylon to degradation. At 225° F Alkaterge C was a satisfactory lubricant and at 350° F is well above scoured nylon, while Myvacet 5-00 is no longer effective. Other satisfactory lubricants are: Glaurin, Liquid Cosmol, Methacrol Lub K, and Sperm Oil (NW) 45.

The Resistance of the Best Class IV Lubricants to Fungi

Nylon is relatively unique among the more common textile materials in its high resistance to destruction by bacteria and fungi. Molds can be induced to grow upon nylon if an applied finish is suitable as a food. Therefore, each application of a lubricant was tested in order to establish whether or not it is resistant to mildewing.

Samples of lubricated nylon line and scoured line, both before and after exposure for 24 hours at 225° F, were sent to the Biochemical Section, Protective Processes Branch, Materials Laboratory, Wright Air Development Center. The fungus susceptibility of the various lubricants applied to the suspension lines was tested by this unit using the method described in Specification MIL-E-5272, Fungus Resistance Test, Procedure I, Paragraph 4.8.1. The Biochemical Unit concluded that all of the lubricants were susceptible to fungus growth, and that the aged and unaged scoured nylon line was not. In most instances the fungus growth was moderate and indicated the possible presence of mildew inhibitors. The manufacturers of the lubricants were contacted to ascertain the exact compositions of their products. All manufacturers stated that no mildew inhibitors were present in their compounds.

Not only was it necessary to determine the resistance of these lubricants to fungi but also the effect of fungus growth on fusion and breaking strength was found. Tests were performed on the aged and unaged samples and the results are presented in Table 12. Of the ten unaged samples exposed to fungi attack, only the following retained a high resistance to fusion as indicated by its class.

	<u>Class</u>	<u>Breaking Strength (lbs)</u>
Ceresine-White-Ozokerite	IV	523
Liquid Cosmol	III-IV*	555
Methacrol Lub K	III	570
Spermaceti	III-IV	547
Spermafol 45	III-IV	548

Of the aged samples exposed to fungi attack only Spermaceti retained the same value of III-IV for its resistance to fusion and a breaking strength of 435 lbs. The others were as follows:

	<u>Class</u>	<u>Breaking Strength (lbs)</u>
Ceresine-White-Ozokerite	II	449
Methacrol Lub K	II	493
Spermafol 45	II	453

* This notation indicates one sample is Class III, the other Class IV.

Conclusions

Liquid Cosmol declined in its ability to prevent fusion to Class I, and hence is considered to be of relatively little value in the prevention of fusion.

It is seen, however, that none of these compounds are useful if a breaking strength of 550 lbs is taken as a minimum value.

SUMMARY OF RESULTS

An instrument based on the belt-friction principle was constructed to study the frictional and fusional effects of scoured and lubricated parachute materials. The experiments were generally conducted over a range of velocities of 25 ft/sec to 75 ft/sec. The following results were obtained:

1. An increase in relative humidity results in an increase in the initial coefficient of sliding friction; however, at the end of a test run, the coefficients of sliding friction decrease and reach the same value regardless of ambient relative humidity.
2. Scoured parachute materials have high frictional forces and fuse at low loads and speeds.
3. In the presence of an adequate amount of lubricant, frictional forces are lower, and higher loads and speeds are used before the onset of fusion.
4. Parachute lubricants have been separated into four classes based upon their comparative ability to prevent fusion at specified loads. Twenty-six lubricants were found to be most effective (Class IV).
5. In order to observe the effect of lubricant on both rubbing surfaces, line and cloth were lubricated. A slight increase in resistance to fusion was observed. In addition, cloth was lubricated and run against scoured line. The results appeared to show that a decrease in resistance to fusion occurred.
6. Experimental silicone treated twill cloth was tested, and it was found that the tendency to fuse was diminished.
7. Class IV lubricants were subjected to aging tests for 24 hours at 225° F. Only ten remained as effective lubricants. These ten were also exposed for one hour at 350° F, and the majority still retained some effectiveness. In addition, breaking strength and fungus resistance tests on aged and unaged samples were performed. The results are arranged in decreasing order of effectiveness for each test in Tables 13, 14, 15, and 16. It is not possible to select a single lubricant as possessing the best overall characteristics, as no lubricant retains a high measure of resistance to breaking, fungi, and aging throughout all tests.

Cover
BIBLIOGRAPHY

1. Dreby, E. C.: A Friction Meter for Determining the Coefficient of Kinetic Friction of Fabrics, J. of Res. N. B. S., 31, 237-246 (1943)
2. Mercier, A. A.: Coefficient of Friction of Fabrics, J. of Res. N. B. S., 5, 243-246 (1930)
3. Hoffman, R. M. and Beste, L. F.: Some Relations of Fiber Properties to Fabric Hand, Text. Res. J., 21, 66 (1951)
4. Frishman, D., Smith, A. L., and Harris, M.: Measurement of the Frictional Properties of Wool Fibers, Text. Res. J. 43, 475-480 (1948)
5. Gralen, N. and Olofsson, B.: Measurement of Friction between Single Fibres, Proc. of the Swedish Inst. for Text. Res., Gothenburg, Sweden, Nr. 3 (1947)
6. Howell, H. G.: Inter-Fibre Friction, J. Text. Inst., 42, T 521-533 (1951)
7. Lincoln, B.: Frictional and Elastic Properties of High Polymeric Materials, J. of Appl. Physics (British), 3, 260-263 (1952)
8. Mercer, E. H. and Makinson, K. R.: The Frictional Properties of Wool and Other Textile Fibres, J. Text. Inst., 38, T 227-240 (1947)
9. Shooter, K. V. and Tabor, F. P.: The Frictional Properties of Plastics, Proc. Roy. Soc., B, LXV, 661 (1952)
10. Palmer, F.: What About Friction?, Pts. I, II, and III, Amer. J. Phys., 17, pp. 181-187, 327-335, 336-342 (1949)
11. Wolf, L.: Molecular-Physical Processes in Lubrication, Mitt. Dtsch. Akad. Luftfahrtforschung, pp. 325-348
12. Bowden, F. P. and Tabor, D.: The Friction and Lubrication of Solids, 1st Ed., Oxford University Press, New York (1950)
13. Rabinowicz, E.: Solid Film Lubrication, Product Engineering, 25, 188-192 (1954)
14. Bowden, F. P. and Tabor, D.: The Friction and Lubrication of Solids, 1st Ed., Oxford University Press, New York (1950)
15. Bondi, A.: Physical Chemistry of Lubricating Oils, 1st Ed., Reinhold Publishing Co., New York (1951)

Contrails

16. Kaswell, E. R.: Textile Fibers, Yarns and Fabrics, Reinhold Publishing Co., New York (1953)
17. Howell, H. G.: The General Case of a String Round a Cylinder, J. Text. Inst., 44, T 359-T 362 (1953)
18. Moss, E.: The Lubrication of Cotton and Other Textiles, British J. Appl. Phys., Suppl. No. 1, 19-23 (1951)
19. Røder, H. L.: Measurements of the Influence of Finishing Agents on the Friction of Fibres, J. Text. Inst., 44, T 247-265 (1953)
20. Bickford, H.: Evaluation of Silicone Oil Formulation as Finishing Material for Nylon Parachute Fabric, Final Report, Contract No. AF 33(038)-21886, United States Air Force, Air Materiel Command, April 24, 1952

Controls
EXPLANATION OF SYMBOLS USED IN THE TABLES AND FIGURES

Symbols Used

RH	Relative humidity (%)
T_1	Slack tension (gm)
T_2	Tight or taut tension (gm)
μ	Coefficient of friction
μ_k	Coefficient of kinetic or sliding friction
θ	Angle or wrap ($^{\circ}$)
$^{\circ}F$	Degrees Fahrenheit
v	Velocity (ft/sec)
F_k or F_S	Kinetic or static frictional force, i. e., slack tension
T	Temperature
%P	Per cent pickup
FL	Fusion load (gm), (slack tension at which fusion occurs)

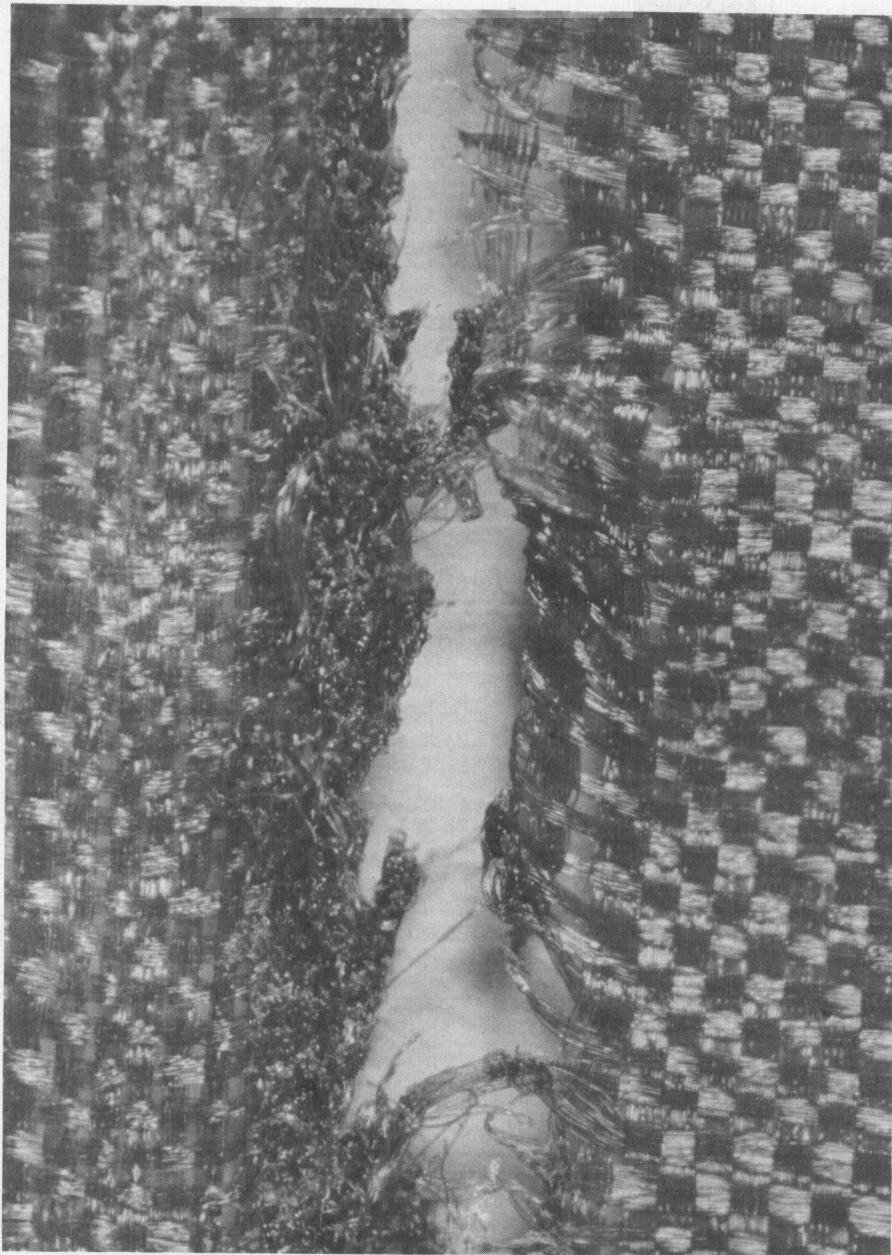

Figure 1

Line Burn on a Parachute Fabric

Contrails

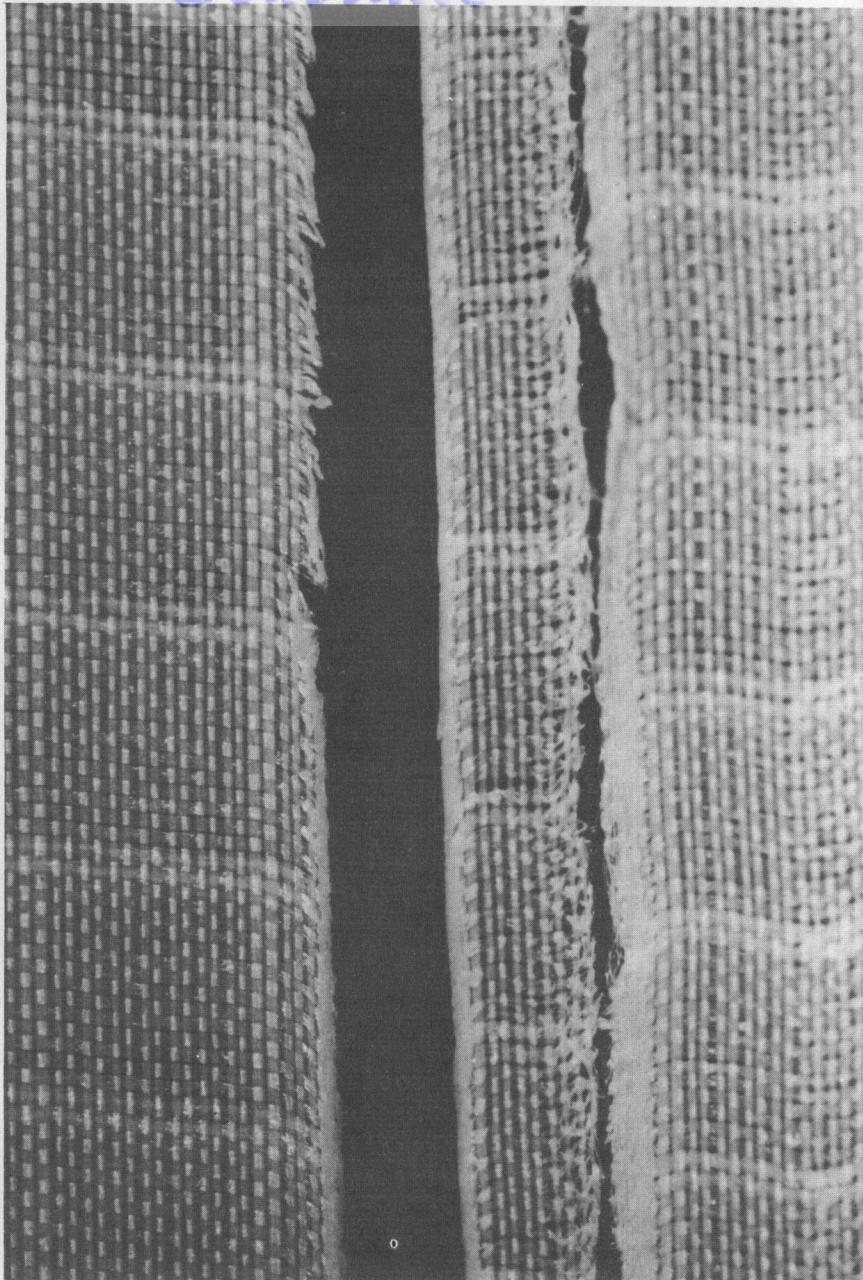

Figure 2

Line Burn on a Parachute Fabric

Produced by the LTIRF Friction Apparatus

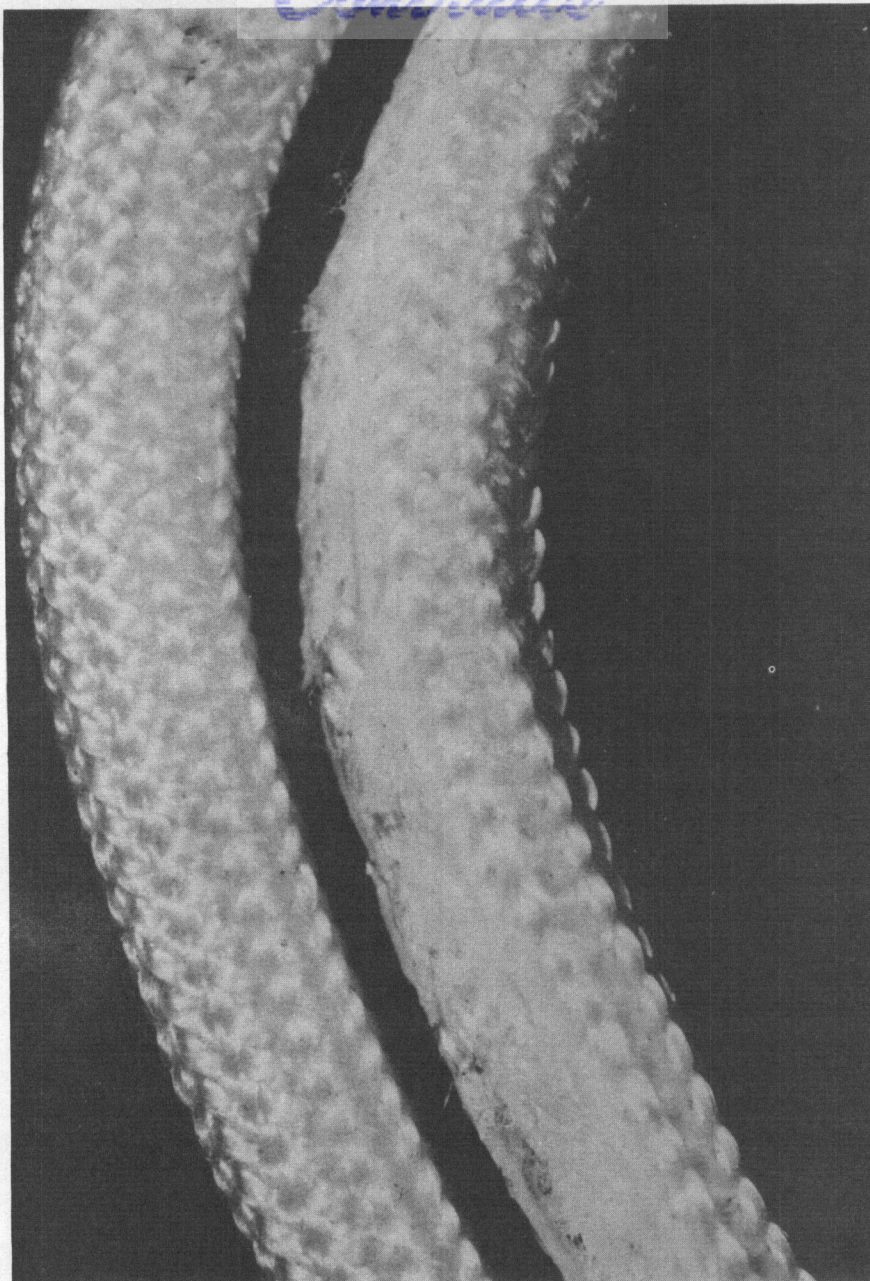

Figure 3

Fusion Damage to Parachute Shroud Line

Produced by LTIRF Friction Apparatus

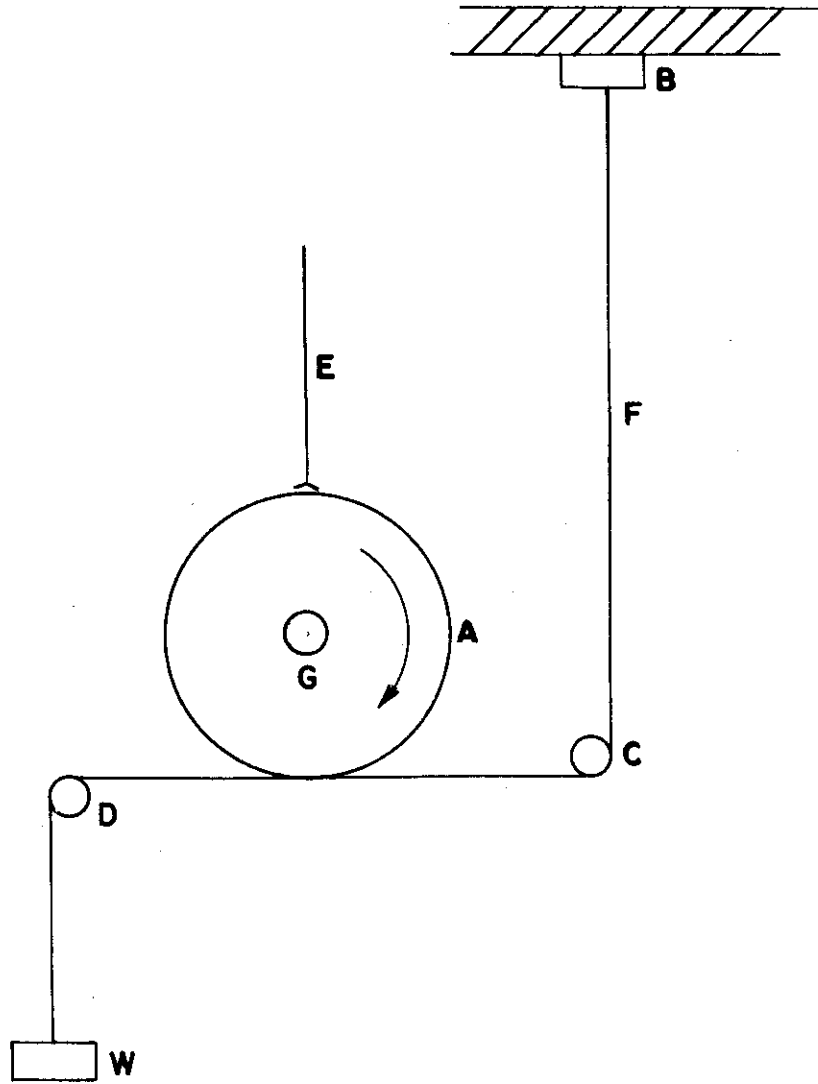

FIGURE 4. DIAGRAM OF HIGH SPEED FRICTION APPARATUS.

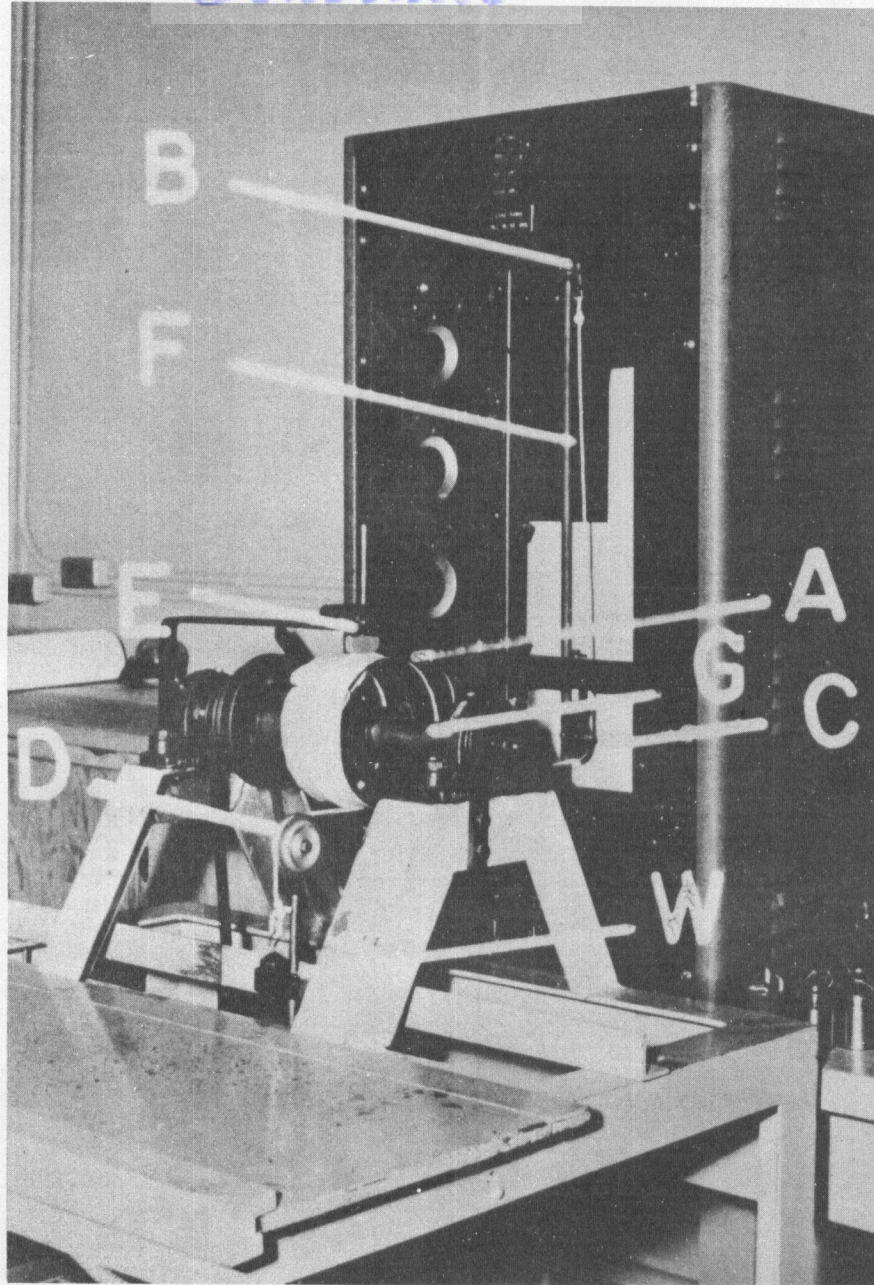

Figure 5

LTIRF High Speed Friction Apparatus

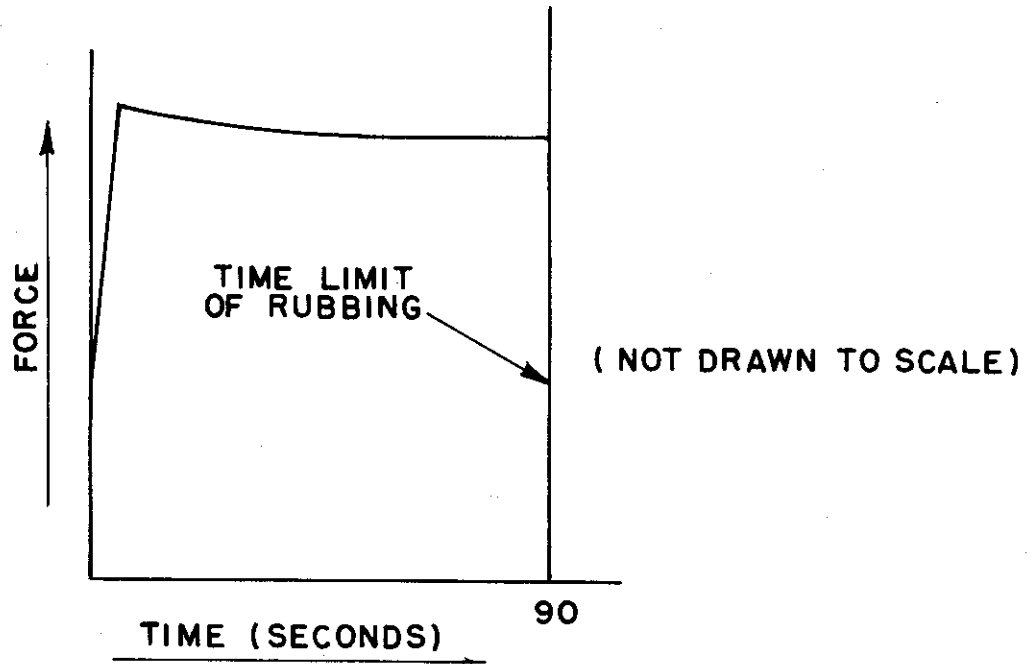

FIGURE 6 IDEALIZED SAMPLE CURVE FROM RECORDER WITHOUT FUSION OCCURRING

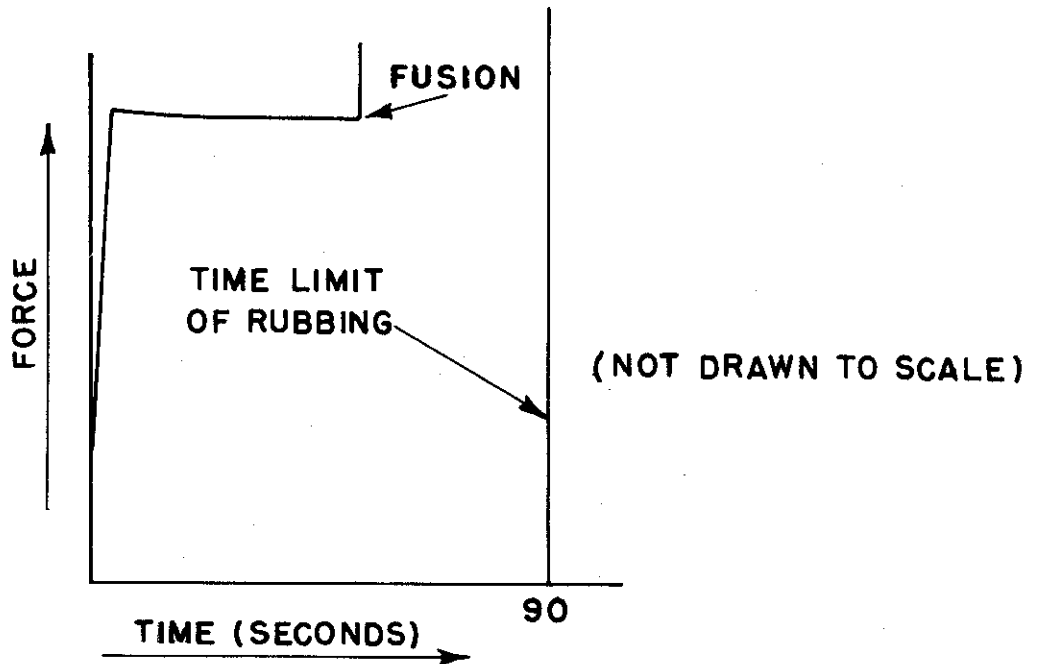

FIGURE 7. IDEALIZED SAMPLE CURVE FROM RECORDER WITH FUSION OCCURRING

$T_1 = 103 \text{ GM}$
 $V = 17 \text{ FT./SEC.}$
 $\theta = 360^\circ$
 $\text{TEMP} = 70^\circ\text{F.}$

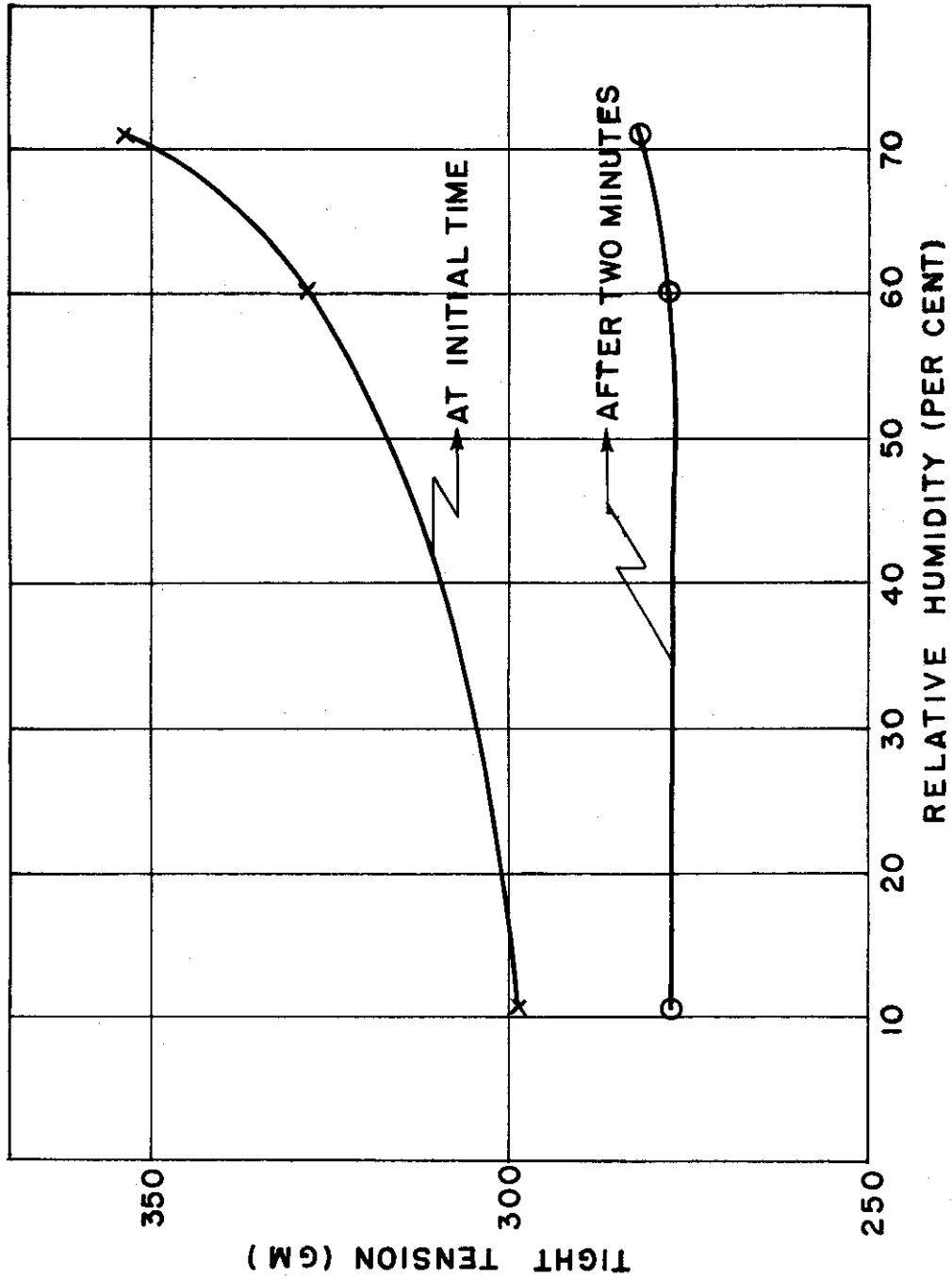

FIGURE 8. THE EFFECT OF RELATIVE HUMIDITY UPON MAXIMUM AND MINIMUM TIGHT TENSION.

Contrails

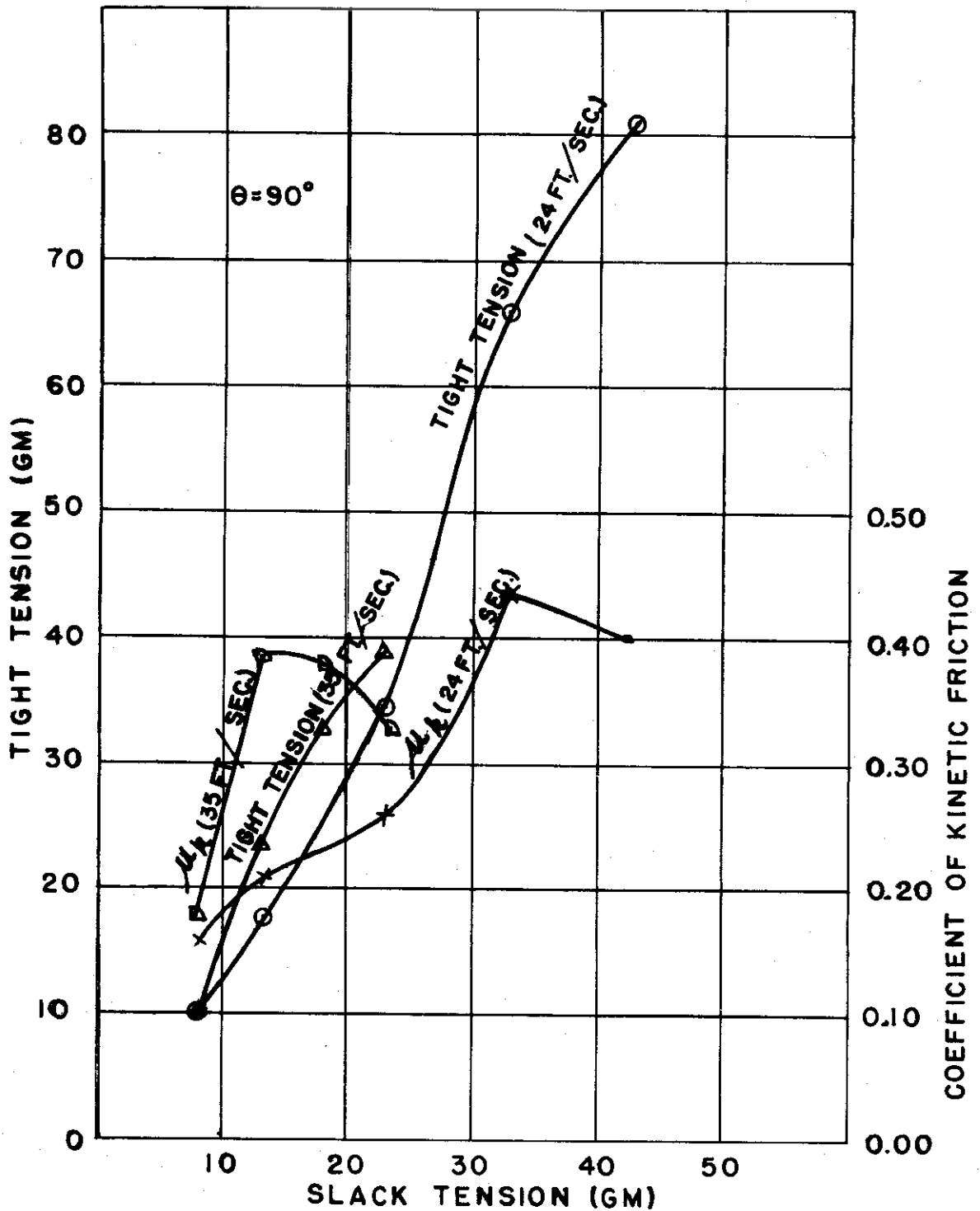

FIGURE 9. THE EFFECT OF SLACK TENSION UPON TIGHT TENSION AND THE COEFFICIENT OF KINETIC FRICTION USING SCOURED CLOTH AND LINE.

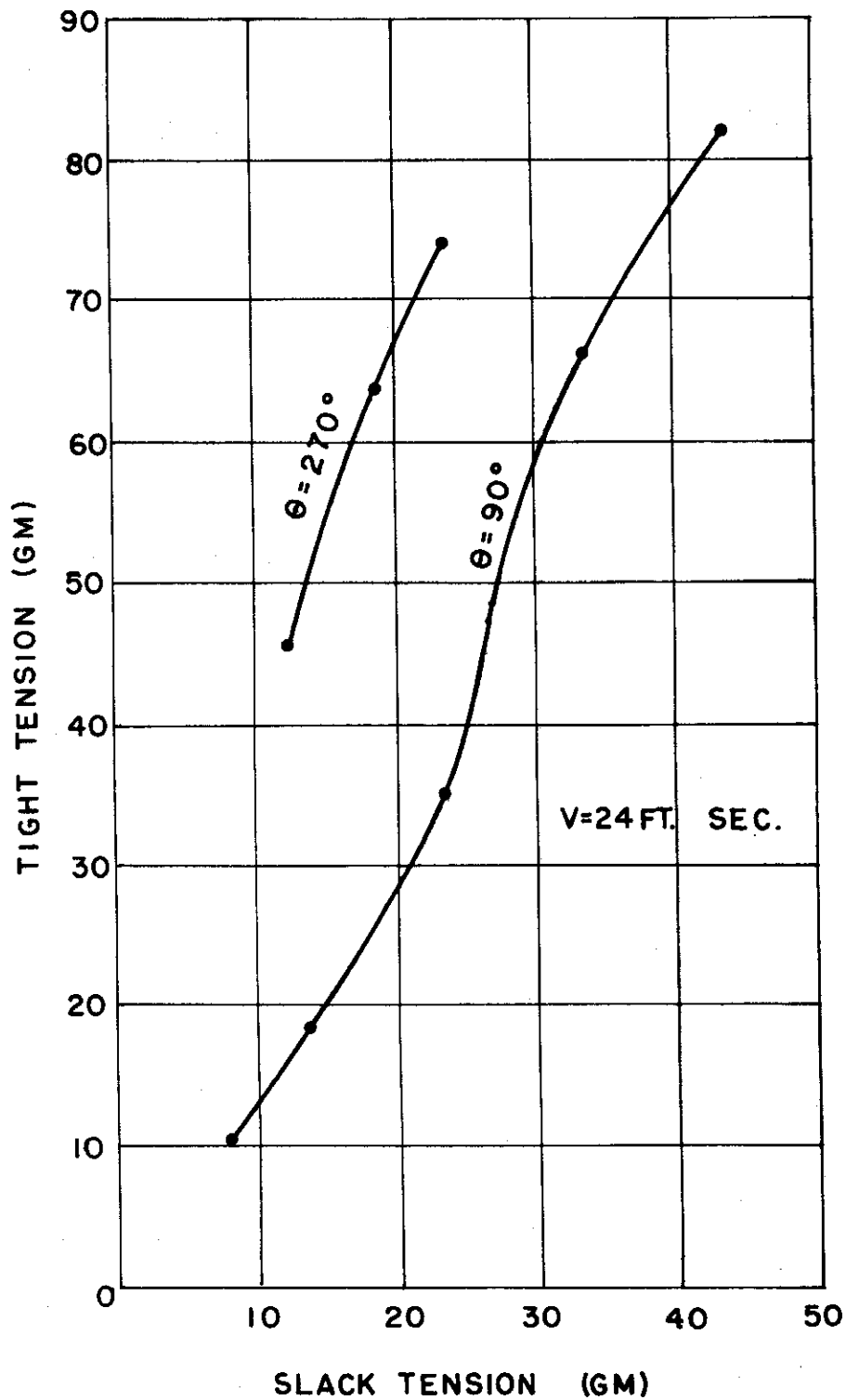

FIGURE 10. THE EFFECT OF SLACK TENSION ON THE TIGHT TENSION WITH VARYING ANGLE OF WRAP USING SCAURED CLOTH AND LINE.

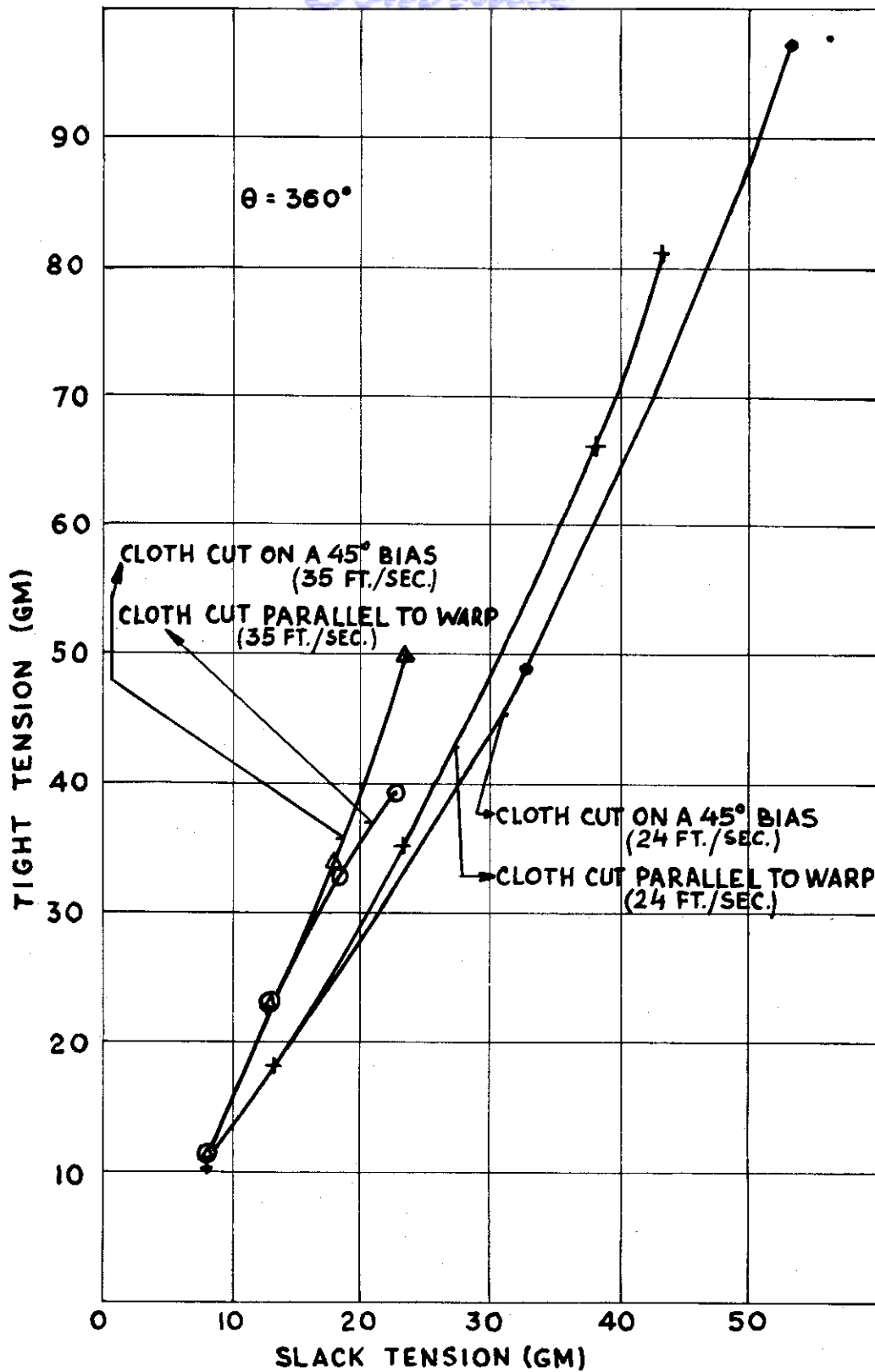

FIGURE II. A COMPARISON OF THE EFFECT OF NORMAL AND BIASED CUTTING OF CLOTH ON TIGHT TENSION.

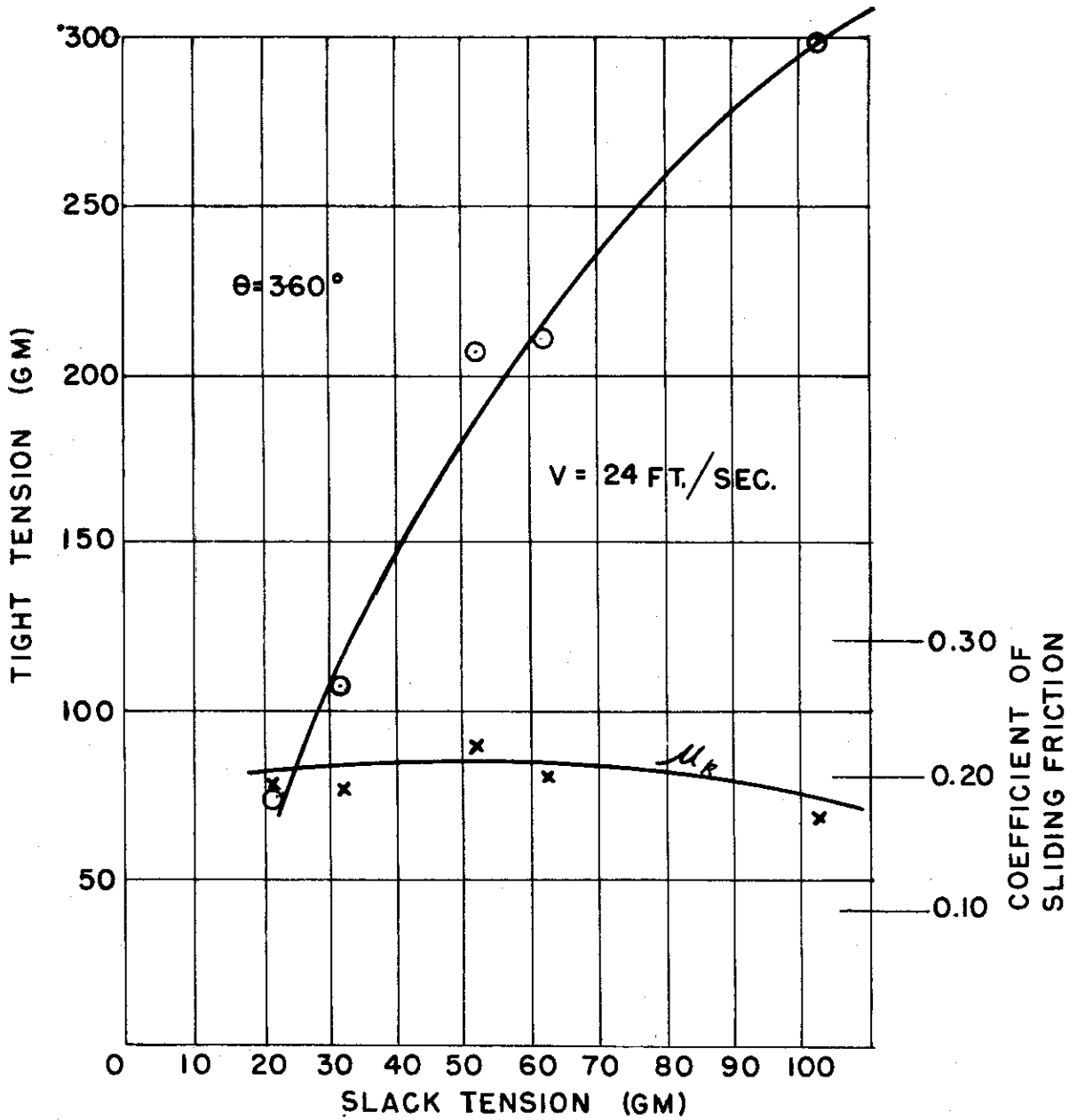

FIGURE 12. THE EFFECT OF SLACK TENSION UPON TIGHT TENSION USING UNSCOURED CLOTH (SPINNING OILS PRESENT) AND LINE.

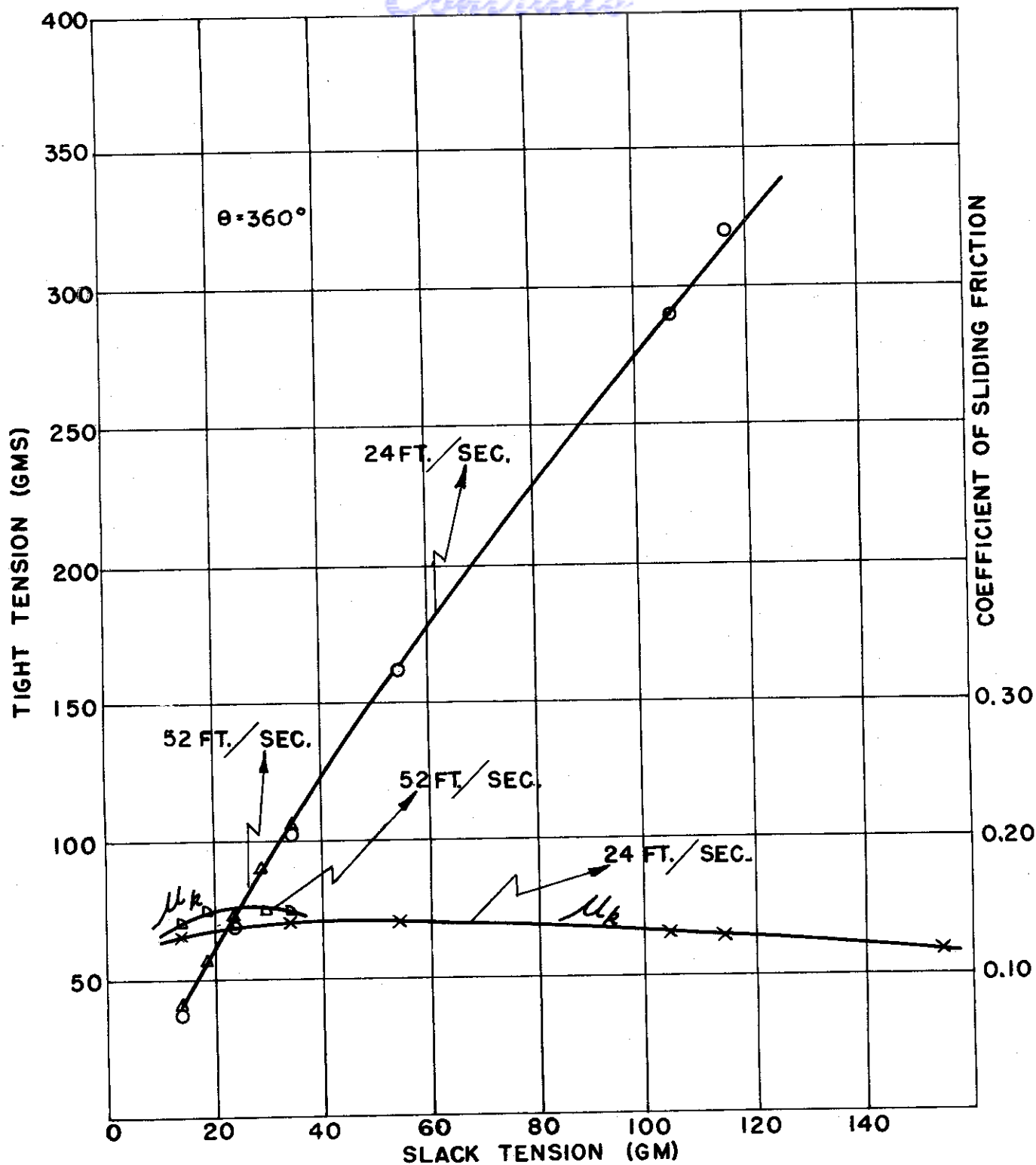

FIGURE 13. THE EFFECT OF SLACK TENSION ON TIGHT TENSION AND THE COEFFICIENT OF SLIDING FRICTION USING CLOTH (SPINNING OILS AND CORONYL PRESENT) AND LINE AS RECEIVED FROM THE MANUFACTURER.

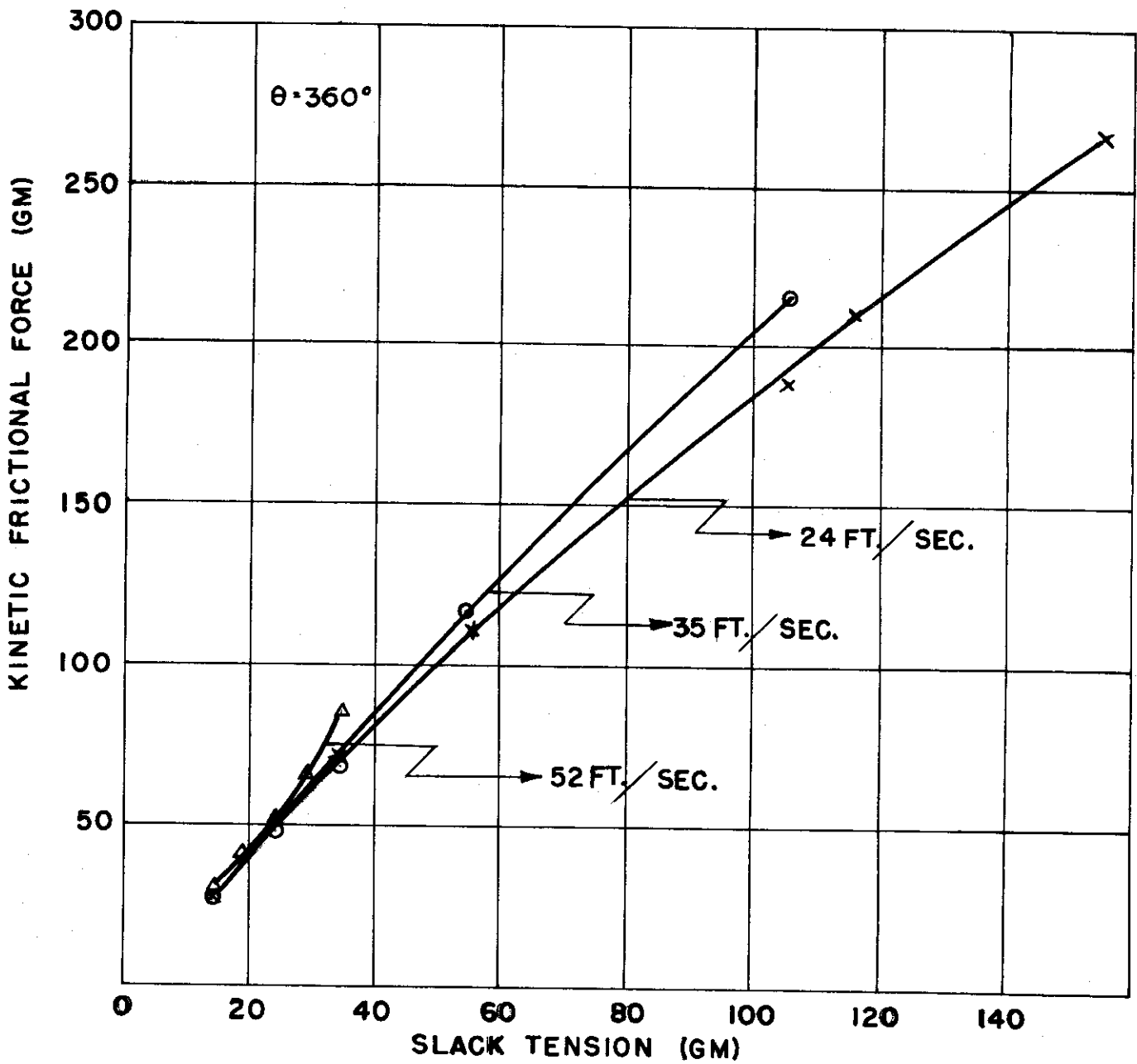
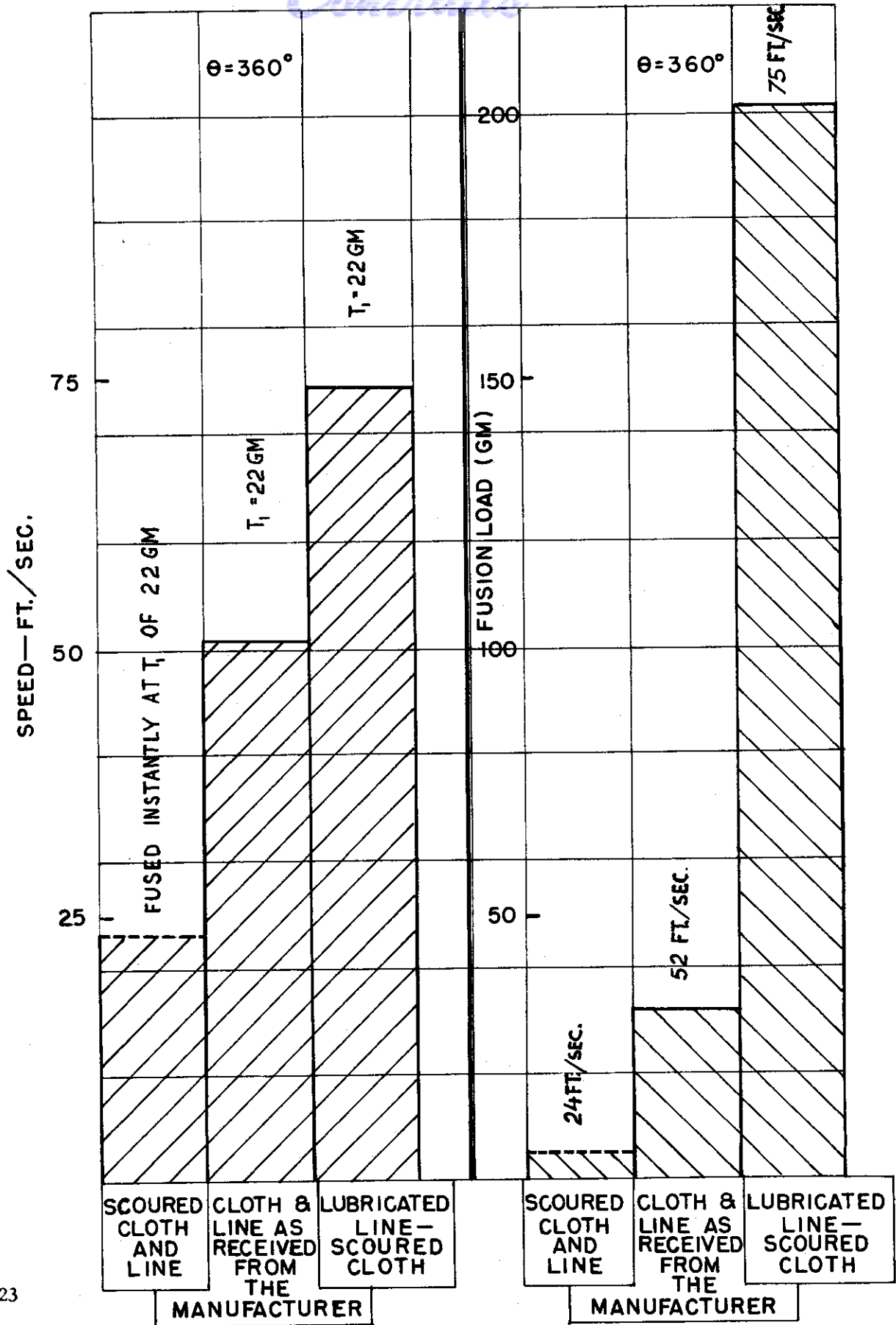

FIGURE 14. THE EFFECT OF SLACK TENSION AND SPEED ON KINETIC FRICTIONAL FORCE USING CLOTH (CONTAINS CORONYL) AS RECEIVED FROM THE MANUFACTURER.



wADC
TR 54,323
Part 1

FIGURE 15. THE EFFECT OF LUBRICATION ON SPEED AND FUSION LOAD.

TABLE 1
(Pages 37 - 60)

THE EVALUATION OF LUBRICANTS IN THE
PREVENTION OF THE FUSION OF PARACHUTE MATERIALS

Controls

	CLASS I	CLASS II	CLASS III	CLASS IV
ALPHA CORPORATION				
MOLYKOTE TYPE U	WIPE ON LINE			
MOLYKOTE SILICONE TYPE M-77	WIPE ON LINE			
ALROSE				
NONISOL 250	5.3			
NONISOL 250	21.4 ⁽¹⁾			
NONISOL 300	4.6 ⁽¹⁾			
NONISOL 300	4.9 ⁽¹⁾			
NONISOL 300	19.3			
ALROSOL	7.6			
ALROSOL	17.0 ⁽¹⁾			
AMERICAN ANILINE & EXTRACT CO.				
ORTHONYL	5.8 ⁽¹⁾			
ORTHONYL	6.3 ⁽¹⁾			
ORTHONYL	10.2			
ORTHONYL	21.9 ⁽¹⁾			
ORTHONYL STS	6.1 ⁽¹⁾			
ORTHONYL STS	5.7 ⁽¹⁾			
ORTHONYL STS	9.5			
ORTHONYL STS	18.3 ⁽¹⁾			

Controls

	CLASS I	CLASS II	CLASS III	CLASS IV
ANTARA CHEMICALS				
AGENT OC-O-151	1.5			
AGENT OC-O-151	5.3			
AGENT OC-O-151	34 ⁽¹⁾			
PRESTABIT OIL V	3.4			
PRESTABIT OIL V	27			
PRESTABIT OIL V	67			
MONOPOL OIL 48	3.3			
MONOPOL OIL 48	58.1 ⁽¹⁾			
SOROMINE FW	3.7			
SOROMINE FW	19.7 ⁽¹⁾			
EMULPHOR 719	5.2 ⁽¹⁾			
EMULPHOR 719	5.2 ⁽¹⁾			
EMULPHOR 719	25 ⁽¹⁾			
ARCHER-DANIELS-MIDLAND CO.				
SPERMAFOL 45		5.2 ⁽¹⁾		
SPERMAFOL 45		5.4 ⁽¹⁾		
SPERMAFOL 45		11.1		
SPERMOIL 45 (NAT. WINTER)		6.0		
SPERMOIL 45 (NAT. WINTER)		10.8 ⁽¹⁾		
SPERMOIL 45 (NAT. WINTER)		10.8 ⁽¹⁾		
SPERMOIL 45 (NAT. WINTER)		20.6 ⁽¹⁾		
SPERMOIL 38 (BLEACHED WINTER)		5.3 ⁽¹⁾		
SPERMOIL 38 (BLEACHED WINTER)		5.7 ⁽¹⁾		
SPERMOIL 38 (BLEACHED WINTER)		16.7 ⁽¹⁾		
COSMOL 1000		5.2		
COSMOL 1000		10.5		
COSMOL 1000		24.2 ⁽¹⁾		
LIQUID COSMOL		5.5		
LIQUID COSMOL		10.9		
LIQUID COSMOL	38	18.7 ⁽¹⁾		

WADC TR
54-323, Part
1

Controls

	CLASS I	CLASS II	CLASS III	CLASS IV
ARKANSAS CO. INC.				
SOLUBLE WOOL OIL	9.8			
SOLUBLE WOOL OIL		18.8 ⁽¹⁾		
ARKO KNITTING OIL F	7.2			
ARKO KNITTING OIL F		9.3		
ARKO KNITTING OIL F		17.3 ⁽¹⁾		
ARKOIL EMULSION	3.2 ⁽¹⁾			
ARKOIL EMULSION		3.4 ⁽¹⁾		
ARKOIL EMULSION		10.5		
ARKOIL EMULSION		20.1		
ARKOLUBE	6.9 ⁽¹⁾			
ARKOLUBE		7.1 ⁽¹⁾		
ARKOLUBE		17.4 ⁽¹⁾		
ARMOUR CHEMICAL DIVISION				
NEO FAT 140	6.3			
NEO FAT 140	17.7 ⁽¹⁾			
ARQUAD 2 HT	5.0			
ARQUAD 2 HT	12			
ARQUAD 2 HT	39			
ARQUAD 2 C	5.8			
ARQUAD 2 C	25.9 ⁽¹⁾			
NEO FAT 14	6.5			
ARMID 0		5.6		
ARMID 0		17.3 ⁽¹⁾		
ARMID 8	5.2			
ARMID 8	20.0			
ETHOMID HT/15		15.8		
ETHOMID HT/15		37.3 ⁽¹⁾		
ETHOMID C/15		19.9		

Controls

	CLASS I	CLASS II	CLASS III	CLASS IV
ARMOUR CHEMICAL DIVISION (CONT)				
ETHOMID RO/20	5.0			
ETHOMID RO/20		22.1		
ETHOMID HT/20	5.6			
ETHOMID HT/20		35.0 ⁽¹⁾		
RD 1882	5.0			
RD 1882		4.9 ⁽¹⁾		
RD 1882		10.5		
RD 1882		20.0 ⁽¹⁾		
RD 1893		10.1		
RD 1893		24.5		
RD 1894		10.1		
RD 1894		29.1		
NEO FAT 94-04	5.5			
NEO FAT 94-04		18.4 ⁽¹⁾		
ETHOFAT 60/60	16.0			
ETHOFAT 60/60		19 ⁽¹⁾		
ETHOMEEN T/60	15.5			
ETHOMEEN T/60		19.2 ⁽¹⁾		
ETHOMEEN 18/60	15.3			
ETHOMEEN 18/60		22.3 ⁽¹⁾		
ETHOFAT 242/60	12.6			
ETHOFAT 242/60		21.6 ⁽¹⁾		
ETHOMEEN S-60	14.0			
ETHOMEEN S-60		23.0 ⁽¹⁾		
ETHOMID HT-60	14.8			
ETHOMID HT-60		18.8 ⁽¹⁾		
ETHOMID RO/60	13.1			
ETHOMID RO/60		20.8 ⁽¹⁾		

Controls

	CLASS I	CLASS II	CLASS III	CLASS IV
ARNOLD HOFFMAN CO.				
EC - 203		19.8 ⁽¹⁾		
LISSAPOL N-380		19.0 ⁽¹⁾		
AHCO III PASTE		31 ⁽¹⁾		
AHCOVEL E & F		15.8 ⁽¹⁾		
AHCOVEL E & F		25.9 ⁽¹⁾		
AHCOTEX W-100		6.6		
AHCOTEX W-100		16.6 ⁽¹⁾		
TECHNICAL BUTYL STEARATE		5.7		
TECHNICAL BUTYL STEARATE		10.4 ⁽¹⁾		
TECHNICAL BUTYL STEARATE		10.4 ⁽¹⁾		
TECHNICAL BUTYL STEARATE		16.7 ⁽¹⁾		
DIST. BUTYL CELLOSOLVE STEARATE		5.8 ⁽¹⁾		
DIST. BUTYL CELLOSOLVE STEARATE		6.0 ⁽¹⁾		
DIST. BUTYL CELLOSOLVE STEARATE		9.1		
DISTILLED BUTYL STEARATE		5.6 ⁽¹⁾		
DISTILLED BUTYL STEARATE		5.7 ⁽¹⁾		
DISTILLED BUTYL STEARATE		11.5		
DISTILLED BUTYL STEARATE		17.7 ⁽¹⁾		
AHCOVEL R	12.8 ⁽¹⁾			
AHCOTEX W-100		16.6 ⁽¹⁾		
LISSAPOL N		11		
LISSAPOL N		32.0		

Controls

	CLASS I	CLASS II	CLASS III	CLASS IV
ATLAS POWDER CO.				
PYCAL 60	4.9			
PYCAL 60		23 ⁽¹⁾		
G-263	2.7			
G-263	7.7			
G-1300	4.3			
G-1300	18.8 ⁽¹⁾			
G-1300		19.6 ⁽¹⁾		
G-1300		23.3		
TWEEN 60	2.3			
TWEEN 60	1.7			
TWEEN 60	3.0			
TWEEN 60		18.3		
TWEEN 40	3.2 ⁽¹⁾			
TWEEN 40		4.5 ⁽¹⁾		
TWEEN 40		18.9		
TWEEN 40		5.0		
TWEEN 20	2.3			
TWEEN 20	5.6 ⁽¹⁾			
TWEEN 20		5.1		
TWEEN 20		16.9		
TWEEN 20		5.4 ⁽¹⁾		
SPAN 40	3.2			
SPAN 40	18.6 ⁽¹⁾			
SPAN 40		2.8		
SPAN 40		4.5		
G-3896	6.1 ⁽¹⁾	INSUFFICIENT SAMPLE		
G-3896	5.5 ⁽¹⁾			

Contrails

	CLASS I	CLASS II	CLASS III	CLASS IV
BAKER CASTOR OIL CO.				
CALCIUM RICINOLEATE	7.1			
CALCIUM RICINOLEATE	29.5			
BARIUM RICINOLEATE	6.8			
MAGNESIUM RICINOLEATE	5.3			
FLEXRICIN 9	5.8			
FLEXRICIN 9	10.8			
FLEXRICIN 9	18.8 ⁽¹⁾			
FLEXRICIN 13	6.1			
FLEXRICIN 13	19.0 ⁽¹⁾			
FLEXRICIN 15	5.6 ⁽¹⁾			
FLEXRICIN 15	5.2 ⁽¹⁾			
FLEXRICIN 15	12			
FLEXRICIN 15	16.6 ⁽¹⁾			
FLEXRICIN 15	16.9 ⁽¹⁾			
CASTORWAX (OPAL WAX)	5.5			
CASTORWAX (OPAL WAX)	17.9 ⁽¹⁾			
CASTORWAX (OPAL WAX)	19.7 ⁽¹⁾			
BARECO OIL CO.				
VICTORY WAX 155 AMBER	5.6			
ULTRACERA AMBER	6.2 ⁽¹⁾			
ULTRACERA AMBER	6.2 ⁽¹⁾			
VICTORY WAX 165 AMBER	3.0			
VICTORY WAX 165 AMBER	13.3			
BE SQUARE SPECIAL WAX	6.4			

Contrails

	CLASS I	CLASS II	CLASS III	CLASS IV
BURKART SCHIER CO.				
BURKEM 288-M0	3.0			
BURKEM 288-M0	9.8			
BURKEM 288-M0	20.9 ⁽¹⁾			
FIBACON L	4.0			
FIBACON L	9.4			
SYNACOL 305 N	4.2			
SYNACOL 305 N	10.0			
CREAMSOL EXTRA	1.7	INSUFFICIENT SAMPLE		
CREAMSOL EXTRA	3.6			
BURKSHIER FINISH 100	2.0			
BURKSHIER FINISH 100	10.1 ⁽¹⁾			
BURKESTER R-1499	6.1 ⁽¹⁾			
BURKESTER R-1499	11.7 ⁽¹⁾			
BURKESTER R-1499	6.6 ⁽¹⁾			
BURKESTER R-1499	11.7 ⁽¹⁾			
BURKESTER R-1499	17.6 ⁽¹⁾			
PARASOL L-1379	3.5			
PARASOL L-1379	9.1 ⁽¹⁾			

Confidential

	CLASS I	CLASS II	CLASS III	CLASS IV
CARBIDE & CARBON CHEMICALS				
POLYPROPYLENE GLYCOL (CARBOWAX) 150	1.3			
POLYPROPYLENE GLYCOL (CARBOWAX) 150	3.78 ⁽¹⁾			
POLYPROPYLENE GLYCOL (CARBOWAX) 425	7.0			
POLYPROPYLENE GLYCOL (CARBOWAX) 425	11.1			
POLYPROPYLENE GLYCOL (CARBOWAX) 425	19.0 ⁽¹⁾			
POLYPROPYLENE GLYCOL (CARBOWAX) 1025	5.6			
POLYPROPYLENE GLYCOL (CARBOWAX) 1025	20.8 ⁽¹⁾			
POLYPROPYLENE GLYCOL (CARBOWAX) 2025	5.2			
POLYPROPYLENE GLYCOL (CARBOWAX) 2025	16.3 ⁽¹⁾			
POLYPROPYLENE GLYCOL (CARBOWAX) 2025	16.4 ⁽¹⁾			
POLYETHYLENE GLYCOL (CARBOWAX) 1000	3.2			
POLYETHYLENE GLYCOL (CARBOWAX) 1000	18.0 ⁽¹⁾			
POLYETHYLENE GLYCOL (CARBOWAX) 1000	17.8 ⁽¹⁾			
POLYETHYLENE GLYCOL (CARBOWAX) 1500	4.0			
POLYETHYLENE GLYCOL (CARBOWAX) 1500	14.2			
POLYETHYLENE GLYCOL (CARBOWAX) 1500	24.8 ⁽¹⁾			
POLYETHYLENE GLYCOL (CARBOWAX) 1540	3.0			
POLYETHYLENE GLYCOL (CARBOWAX) 1540	16.4			
POLYETHYLENE GLYCOL (CARBOWAX) 4000	4.1			
POLYETHYLENE GLYCOL (CARBOWAX) 4000	18.0			

Controls

	CLASS I	CLASS II	CLASS III	CLASS IV
CARBIDE & CARBON CHEMICALS (CONT.)				
POLYETHYLENE GLYCOL (CARBOWAX) 6000	4.1			
POLYETHYLENE GLYCOL (CARBOWAX) 6000	15.4			
POLYETHYLENE GLYCOL (CARBOWAX) 200	3.5			
POLYETHYLENE GLYCOL (CARBOWAX) 200	17.0			
POLYETHYLENE GLYCOL (CARBOWAX) 300	3.7			
POLYETHYLENE GLYCOL (CARBOWAX) 300	17.7			
POLYETHYLENE GLYCOL (CARBOWAX) 400	3.9			
POLYETHYLENE GLYCOL (CARBOWAX) 400	15.7 ⁽¹⁾			
POLYETHYLENE GLYCOL (CARBOWAX) 400	15.7 ⁽¹⁾			
POLYETHYLENE GLYCOL (CARBOWAX) 400	11.3			
POLYETHYLENE GLYCOL (CARBOWAX) 600	4.9			
POLYETHYLENE GLYCOL (CARBOWAX) 600	10.3 ⁽¹⁾			
POLYETHYLENE GLYCOL (CARBOWAX) 600	10.2 ⁽¹⁾			
UCON LUBRICANT 50-HB-2000	3.9			
UCON LUBRICANT 50-HB-2000	18.0			
UCON LUBRICANT LB-1145	7.6			
UCON LUBRICANT LB-1145	22.4 ⁽¹⁾			
DIETHYLENE GLYCOL	2.0			
DIETHYLENE GLYCOL	17.6			

Controls

	CLASS I	CLASS II	CLASS III	CLASS IV
COLLOIDS INC.				
DELECTROL 374	3.9 ⁽¹⁾			
DELECTROL 374	10.4 ⁽¹⁾			
DELECTROL 374		3.9 ⁽¹⁾		
DELECTROL 374		10.4 ⁽¹⁾		
DELECTROL 374		20.6 ⁽¹⁾		
DELECTROL 379	5.1 ⁽¹⁾			
DELECTROL 379		5.3 ⁽¹⁾		
DELECTROL 379		17.7 ⁽¹⁾		
DELECTROL 376	4.7			
DELECTROL 376		18.2 ⁽¹⁾		
HYGROLIZED OIL 220	4.4			
HYGROLIZED OIL 220		21.3 ⁽¹⁾		
COMMERCIAL SOLVENTS CORP.				
ALKATERGE C		8.6		
GLUCATERGE R-12	6.5			
GLUCATERGE R-12	20.1 ⁽¹⁾			
GLUCATERGE R 28	6.0			
GLUCATERGE R 28	21 ⁽¹⁾			
DEXTER CHEMICAL CORP.				
DEXTROL 986	4.4			
DEXTROL 986		11.0		
DEXTROL 986		17.0 ⁽¹⁾		

Contrails

	CLASS I	CLASS II	CLASS III	CLASS IV
DISTILLATION PRODUCTS INDUSTRIES				
MYVACET 5-00		9.8		
MYVACET 5-00			12.6	
MYVACET 9-40		14.2 ⁽¹⁾		
MYVACET 9-40			11.7	
MYVACET 9-40			13.7 ⁽¹⁾	
MYVEROL 18-40	5.0 ⁽¹⁾			
MYVEROL 18-40		10.8		
MYVEROL 18-40		13.2 ⁽¹⁾		
MYVEROL 18-40			13.2 ⁽¹⁾	
MYVEROL 18-05	4.5 ⁽¹⁾			
MYVEROL 18-05		13.6		
MYVEROL 18-05			17.7 ⁽¹⁾	
MYVEROL 18-00		4.7		
MYVEROL 18-00		18 ⁽¹⁾		
MYVEROL 18-00			13.3	

Controls

	CLASS I	CLASS II	CLASS III	CLASS IV
DOW CHEMICAL CO.				
POLYGLYCOL E 200	8.9			
POLYGLYCOL E 200	4.4			
POLYGLYCOL E 200		25.4 ⁽¹⁾		
POLYGLYCOL E 300	4.8			
POLYGLYCOL E 300		10.8 ⁽¹⁾		
POLYGLYCOL E 300		11.1		
POLYGLYCOL E 300		22.2 ⁽¹⁾		
POLYGLYCOL E 400		4.8		
POLYGLYCOL E 400		19.7 ⁽¹⁾		
POLYGLYCOL E 400		20.3 ⁽¹⁾		
POLYGLYCOL E 600		4.5		
POLYGLYCOL E 600		10.7		
POLYGLYCOL E 600		23.2 ⁽¹⁾		
POLYGLYCOL E 600		22.6 ⁽¹⁾		
POLYGLYCOL P 2000	17.4 ⁽¹⁾			
POLYGLYCOL P 2000		18.0 ⁽¹⁾		
POLYGLYCOL P 3000	13.6			
POLYGLYCOL P 3000		30 ⁽¹⁾		
POLYGLYCOL P 4000	13.6			
POLYGLYCOL P 4000		16.8 ⁽¹⁾		
POLYGLYCOL E 600 METHYL ETHER		10.2 ⁽¹⁾		
POLYGLYCOL E 600 METHYL ETHER		9.9 ⁽¹⁾		
POLYGLYCOL P 600 METHYL ETHER	9.0 ⁽¹⁾			
POLYGLYCOL P 600 METHYL ETHER		9.5 ⁽¹⁾		
POLYGLYCOL P 600 METHYL ETHER		22.9 ⁽¹⁾		
POLYGLYCOL P 600 X-OCTYL ETHER		10.5 ⁽¹⁾		
POLYGLYCOL P 600 X-OCTYL ETHER		10.5 ⁽¹⁾		
POLYGLYCOL E 600 X-OCTYL ETHER		11.3 ⁽¹⁾		
POLYGLYCOL E 600 X-OCTYL ETHER		11.7 ⁽¹⁾		
POLYGLYCOL 15-200	49	19.4		

WADC TR
54-323,
Part 1

Controls

	CLASS I	CLASS II	CLASS III	CLASS IV
DREW, E.F., CO.				
DRUSTAT H	5.3			
DRUSTAT H	19.5 ⁽¹⁾			
DRUSTAT	6.8			
DRUSTAT	14.4			
DRUSTAT	24.5 ⁽¹⁾			
CORONYL	3.1			
CORONYL		8.5		
CORONYL		11.3		
CORONYL			25.0 ⁽¹⁾	
DRUSPIN A.D.	5.3			
DRUSPIN A.D.		16.1		
SOLUBLE LUXOLENE	3.0			
SOLUBLE LUXOLENE	9.9			
SOLUBLE LUXOLENE	20.2 ⁽¹⁾			

Contracts

	CLASS I	CLASS II	CLASS III	CLASS IV
DU PONT DE NEMOURS				
AVITEX R	19.5 ⁽¹⁾			
AVITEX R	1.6			
AVITEX R	5.4			
AVITEX R	19.9 ⁽¹⁾			
AVITEX C	9.4 ⁽¹⁾			
AVITEX C	1.4			
AVITEX C	5.0 ⁽¹⁾			
AVITEX C	5.0 ⁽¹⁾			
AVITEX C	10.1 ⁽¹⁾			
AVITEX C	30 ⁽¹⁾			
AVITONE A	5.3			
AVITONE A	13.3 ⁽¹⁾			
AVITONE A	34.5			
AVITONE AL	28.5			
AVITONE AL	3.5			
PRODUCT B C O	2.8			
PRODUCT B C O	7.9			
PRODUCT B C O	16.5 ⁽¹⁾			
METHACROL LUB C	5.6			
METHACROL LUB C	14.2			
METHACROL LUB K	2.9			
METHACROL LUB K	4.8			
METHACROL LUB K	11.4 ⁽¹⁾			
METHACROL LUB K	23.1			
METHACROL LUB K	11.4 ⁽¹⁾			
LOROL 28	5.4			
LOROL 28	21.4 ⁽¹⁾			
OCENOL	4.7			
OCENOL	17.8 ⁽¹⁾			
OCENOL	17.9 ⁽¹⁾			
LOROL 5	4.8			
TEFLON	11.4			

WADC TR
54-323,
Part 1

Controls

	CLASS I	CLASS II	CLASS III	CLASS IV
EMERY INDUSTRIES INC.				
EMERY 2302		9.5 ⁽¹⁾		
EMERY 2302		9.5 ⁽¹⁾		
EMERY 2302		19.0 ⁽¹⁾		
EMERSOL 233	11.1			
EMERSOL 233		21.9 ⁽¹⁾		
EMERY 955	21.5 ⁽¹⁾			
EMERY 2230		10.0		
EMERY 2230		20.0 ⁽¹⁾		
GENERAL ELECTRIC CO.				
FLUID A		9.2		
FLUID B		23.0 ⁽¹⁾		
FLUID C		16.4		
FLUID D		18.8 ⁽¹⁾		
FLUID E		17.2		
FLUID F		23.8 ⁽¹⁾		
FLUID G		13.2		
FLUID H		20.7		
FLUID I	11.0			
FLUID J	21.4			

Contrails

	CLASS I	CLASS II	CLASS III	CLASS IV
GLYCO PRODUCTS INC.				
AQUARESIN	3.4			
AQUARESIN	21.7			
ALBACER	17.5			
ALBACER	2.9			
DIGLYCOL OLEATE S	1.9			
DIGLYCOL OLEATE S	17.5			
ACROWAX C	1.8			
ACROWAX C	8.5			
STROBAWAX	1.6			
STROBAWAX	20.6			
DIGLYCOL STEARATE S	1.4			
DIGLYCOL STEARATE S	16.3 ⁽¹⁾			
DIGLYCOL STEARATE S	17.8 ⁽¹⁾			
ACROWAX B	3.5			
ACROWAX B	18.7			
GLYCERYL MONOLAURATE	10.7 ⁽¹⁾			
GLYCERYL MONOLAURATE	1.4 ⁽¹⁾			
GLYCERYL MONOLAURATE	10.7 ⁽¹⁾			
GLYCERYL MONOLAURATE	35.5 ⁽¹⁾			
GLYCOWAX S-932	1.9			
GLYCOWAX S-932	16.2			
POLYETHYLENE GLYCOL (MONO) ⁴⁰⁰ LAURATE	2.4			
POLYETHYLENE GLYCOL (MONO) ⁴⁰⁰ LAURATE	11.4			
FLEXOWAX C	2.8			
FLEXOWAX C	15.1			
FLEXOWAX C	14.1 ⁽¹⁾			
GLAURIN	1.4			
GLAURIN	1.5			
GLAURIN	16.9			
CERAMID	2.5			
CERAMID	53	13.9		

WADC TR 54-323
Part 1

Contrails

	CLASS I	CLASS II	CLASS III	CLASS IV
HERCULES POWDER CO.				
HERCOLYN	2.8			
HERCOLYN		18.6		
ABITOL	5.3			
ABITOL	13.5			
METALYN	5.3			
METALYN		8.0 ⁽¹⁾		
METALYN			7.7 ⁽¹⁾	
METALYN			18.1 ⁽¹⁾	
HEYDEN CHEMICAL CORP.				
FLEXIN P	4.9			
FLEXIN P	17.2			
HOOKER ELECTROCHEMICAL CO.				
FLUOROLUBE S	8.3			
FLUOROLUBE S		18.6 ⁽¹⁾		
FLUOROLUBE H.O.	9.6			
FLUOROLUBE H.O.		19.1 ⁽¹⁾		
FLUOROLUBE M.G.	9.4			
FLUOROLUBE M.G.		20.7 ⁽¹⁾		
HOWE & FRENCH CO.				
C-160 SPERM OIL			3.7	
C-160 SPERM OIL			15.3	
JACQUES WOLF & CO.				
MONOPOL OIL	2.1			
MONOPOL OIL		17.9 ⁽¹⁾		
MASURY YOUNG CO.				
SCOTCH NYLON COMPOUND 650		11.9		
SCOTCH NYLON COMPOUND 650			21.8	

Contrails

	CLASS I	CLASS II	CLASS III	CLASS IV
MATHESON CO.				
ETHYL OLEATE	8.4 ⁽¹⁾			
ETHYL OLEATE		8.7 ⁽¹⁾		
ETHYL OLEATE		8.4 ⁽¹⁾		
ETHYL OLEATE			8.6 ⁽¹⁾	
ETHYL OLEATE			9.4 ⁽¹⁾	
ETHYL OLEATE				9.4 ⁽¹⁾
ETHYL OLEATE				21.1 ⁽¹⁾
MINNESOTA MINING & M'F'G CO.				
F-126	8.0			
F-126	16.3 ⁽¹⁾			
PERFLUOROOCTANOIC ACID	3.9			
PERFLUOROOCTANOIC ACID	14.7 ⁽¹⁾			
PERFLUORODECANOIC ACID	3.9			
PERFLUORODECANOIC ACID	12.0 ⁽¹⁾			
FC-8215	4.8			
FC-804	4.0			
MONSANTO CHEMICAL CO.				
MERLON BR	10.2			

Contrails

	CLASS I	CLASS II	CLASS III	CLASS IV
NOPCO CHEMICAL CO.				
NOPCO IIII	8.9			
NOPCO IIII	22.0 ⁽¹⁾			
NOPCO RSF NO.7	11.9			
NOPCO RSF NO.7	20.4 ⁽¹⁾			
NOPCO RSF NO.15	13.4 ⁽¹⁾			
NOPCO RSF NO.15	13.7 ⁽¹⁾			
NOPCO RSF NO.15	38.0 ⁽¹⁾			
NOPCO C.P. SOLUBLE	9.0			
NOPCO C.P. SOLUBLE	21.8 ⁽¹⁾			
NOPCO 2067 X	8.7 ⁽¹⁾			
NOPCO 2067 X	9.4 ⁽¹⁾			
NOPCO 2152 X	8.2 ⁽¹⁾			
NOPCO 2152 X	8.8 ⁽¹⁾			
ORONITE CHEMICAL CO.				
DISPERSANT Ni-W	12.2			
DISPERSANT Ni-W	22.6 ⁽¹⁾			
DISPERSANT Ni-O	10.5			
DISPERSANT Ni-O	23.2 ⁽¹⁾			
POLYBUTENE NO. 24	9.3			
POLYBUTENE NO. 24	20.5 ⁽¹⁾			
POLYBUTENE NO. 32	9.9			
POLYBUTENE NO. 32	22 ⁽¹⁾			
POLYBUTENE NO. 128	10.7			
POLYBUTENE NO. 128	26 ⁽¹⁾			

Continued

	CLASS I	CLASS II	CLASS III	CLASS IV
PETROLITE CORPORATION				
CROWN WAX 1035		13.4		
CROWN WAX 700		7.8 ⁽¹⁾		
CROWN WAX 700		7.8 ⁽¹⁾		
CROWN WAX 700		28.5 ⁽¹⁾		
CROWN WAX 500		29.0 ⁽¹⁾		

ROHM & HAAS				
RHOTEX 200	5.7			
RHOTEX 200	19.8 ⁽¹⁾			
TRITON K-60	14.6			
SHARPLES CHEMICAL INC.				
AMYL STEARAMIDE		10.7		
SHERWOOD REFINERY CO.				
AMBER PETROLATUM		9.6		
AMBER PETROLATUM		20.8 ⁽¹⁾		
STARLIGHT 125 OIL		7.2		
SHEROWAX 40 YELLOW		14.8 ⁽¹⁾		
SHEROWAX 40 YELLOW		14.7 ⁽¹⁾		
SHEROLATUM RED VETERINARY		14.3		

Controls

	CLASS I	CLASS II	CLASS III	CLASS IV
STEPAN CHEMICAL CO.				
MAKANOL NO.1		9.2		
MAKANOL NO.1		21.0 ⁽¹⁾		
MAKANOL NO.2		8.7		
SYNTHETIC CHEMICALS INC.				
NEGAMINE 142 A		22.4 ⁽¹⁾		
INTRACOL R	23.6 ⁽¹⁾			
INTRACOL O		25.2		
INTRACOL OA		22.7 ⁽¹⁾		
THOMAS, A.T.				
CERESINE - WHITE - OZOKERITE		10.2		
VIRGINIA- CAROLINA CHEM. CORP.				
DIBUTYL BUTYL PHOSPHONATE	7.0			
DIBUTYL BUTYL PHOSPHONATE		21.6 ⁽¹⁾		
BIS(2 ETHYLHEXYL)2- ETHYLHEXYL PHOSPHATE		8.6 ⁽¹⁾		
BIS(2 ETHYLHEXYL)2- ETHYLHEXYL PHOSPHATE		8.3 ⁽¹⁾		
BIS(2 ETHYLHEXYL)2- ETHYLHEXYL PHOSPHATE		9.5		
BIS(2 ETHYLHEXYL)2- ETHYLHEXYL PHOSPHATE		23.8 ⁽¹⁾		

Contrails

	CLASS I	CLASS II	CLASS III	CLASS IV
WARWICK CHEMICAL CO.				
WARCO WAX NO 180 WHITE		13.8		
MEKON Y-20		11.4 ⁽¹⁾		
MEKON Y-20		11.3 ⁽¹⁾		
CARDIS NO. 262	12.5 ⁽¹⁾			
CARDIS NO. 262		12.9 ⁽¹⁾		
FORTEX		9.8 ⁽¹⁾		
FORTEX		11.4 ⁽¹⁾		
CARDIS NO. 320		11.4		
WARCOSINE		12.7		
WYANDOTTE CHEMICAL CORP.				
PLURONIC L 44	11.1			
PLURONIC L 44		23.1 ⁽¹⁾		
PLURONIC L 62	10.1			
PLURONIC L 62		27.8 ⁽¹⁾		
PLURONIC L 64	12.2 ⁽¹⁾			
PLURONIC L 64		11.7 ⁽¹⁾		
PLURONIC L 64		19.5 ⁽¹⁾		
PLURONIC F 68	11.2			
PLURONIC F 68		24.2 ⁽¹⁾		
PLURONIC L 62 (DISTEARATE)	10.2			
PLURONIC L 62 (DISTEARATE)		22.0 ⁽¹⁾		
PLURONIC L 64 (DISTEARATE)		9.2		
PLURONIC L 64 (DISTEARATE)		20.0 ⁽¹⁾		

Contrails

	CLASS I	CLASS II	CLASS III	CLASS IV
CHEMICALLY & TECHNICALLY PURE COMPOUNDS				
GLYCERINE U. S. P.	5.6			
GLYCERINE U. S. P.	22 ⁽¹⁾			
PALMITIC ACID C. P.	3.6			
RICINOLEIC ACID TECH.	4.6			
LINOLEIC ACID C. P.	4.1			
OLEIC ACID U. S. P.	5.4			
METHYL STEARATE C. P.	4.2			
DIBUTYL PHTHALATE	5.5			
DIBUTYL PHTHALATE	9.0			
DIBUTYL PHTHALATE			29.2 ⁽¹⁾	
BUTYL STEARATE	4.8 ⁽¹⁾			
BUTYL STEARATE	3.8 ⁽¹⁾			
SPERMACETI U. S. P.		6.4		
SPERMACETI U. S. P.		17.1 ⁽¹⁾		
SPERMACETI U. S. P.		9.7		
CYCLO HEXYL MALEATE	4.7			
CAPRYLIC ACID C. P.	9.2			
CAPRIC ACID C. P.	2.1			
CAPRIC ACID C. P.	10.8			
LAURIC ACID C. P.	4.9			
LAURIC ACID C. P.	10.8			
MYRISTIC ACID C. P.	4.3			
MYRISTIC ACID C. P.	10.4			
STEARIC ACID C. P.	3.0			
STEARIC ACID C. P.	9.6			
DODECYL ALCOHOL C. P.	4.6			
DODECYL ALCOHOL C. P.	9.3			
MYRISTYL ALCOHOL C. P.	5.8			
MYRISTYL ALCOHOL C. P.	10.9			
1-OCTADECANOL C. P.	9.3			
ETHYL LAURATE C. P.	9.6			
ETHYL MYRISTATE C. P.		10.8		
ETHYL STEARATE C. P.		10.3		
SODIUM OLEATE TECH.	4.2			
SODIUM RICINOLEATE TECH.	4.4			

TABLE 2

CLASS IV LUBRICANTS

	<u>Company</u>	<u>Percent Pickup</u>	<u>Type of Compound</u>	<u>Molecular Weight or No. of C</u>
1.	Alkaterge C	8.6	Substituted Oxazoline, nonionic	
2.	Arko Emulsion	11.4	Not Available	
3.	Arko Knitting Oil F	9.9	Not Available	
4.	Ceresine-White-Ozokerite	9.0	Mineral Wax, Hydrocarbon type	
5.	Distilled Butyl Cello-solve Stearate	9.1	$C_4H_9-O-CH_2-CH_2-OCO-(CH_2)_{16}CH_3$	24
6.	Distilled Butyl Stearate	11.5	$C_4H_9OCO (CH_2)_{16}CH_3$	22
7.	Emory 2302	9.5	Propyl Oleate, $CH_3(CH_2)_7-CH=CH (CH_2)_7COOCH_2C_2H_5$	21
8.	Ethyl Oleate, Tech.	9.4	$CH_3(CH_2)_7-CH=CH(CH_2)_7COO C_2H_5$	20
9.	Glaurin	8.9	Diethylene Glycol (Mono) Laurate	16

TABLE 2 - continued

	<u>Company</u>	<u>Percent Pickup</u>	<u>Type of Compound</u>	<u>Molecular Weight or No. of C</u>
10.	Liquid Cosmol Archer Daniels Midland	9.9	Esters of Highly Unsaturated Fatty Acids and Alcohols (C12-C20)	12-20
11.	Methacrol Lub K du Pont	11.4	Not Available	
12.	Myvacet 5-00 Distillation Products Industries	12.6	Derived from monoglyceride of hydrogenated lard monoester	
13.	Myvacet 9-40 Distillation Products Industries	9.5	Derived from monoglyceride of hydrogenated lard monoester	
14.	Nopco 2L52-X Nopco	8.8	Not Available	m.w. = 600
15.	Polyglycol E600 Methyl Ether Dow	9.9	$H-(O-CH_2-CH_2)_n-O-CH_3$	
16.	Polyglycol E600-X- Octyl Ether Dow	11.7	$H-(-O-CH_2-CH_2)_n-OH$	m.w. = 600
17.	Polyglycol P600-X- Octyl Ether Dow	10.5	$ \begin{array}{c} H & H & H & H \\ & & & \\ HO-C & -C & -C & -C-O \\ & & & \\ CH_3 & & & CH_3 \end{array} $	m.w. = 600
18.	Polyethylene Glycol 400 Carbide and Carbon Chemical Co.	11.3	$H(O-CH_2-CH_2)_n-OH$	m.w. = 400

TABLE 2 - concluded

	<u>Company</u>	<u>Percent Pickup</u>	<u>Type of Compound</u>	<u>Molecular Weight or No. of C</u>
19.	Polyethylene Glycol 400 (Mono) Laurate Glyco	11.3	H-(O-CH ₂ -CH ₂) _n OOC (CH ₂) ₁₀ CH ₃	m.w. = 400
20.	RD 1882 Armour Chemical	10.5	Principally lard oil; a glyceryl ester	
21.	Spermaceti, U.S.P.	9.7	Cetyl palmitate, C ₁₅ H ₃₁ COO C ₁₆ H ₃₃	32
22.	Spermafol 45 Archer Daniels Midland	9.7	Chiefly Esters of C ₁₂ to C ₁₈ chain length fatty acids and C ₁₄ to C ₁₈ chain length fatty alcohols	12-18
23.	Sperm Oil 45 (NW) Archer Daniels Midland	10.8	Chiefly Esters whose average molecular structure is C ₁₅ H ₂₉ COOC ₁₆ H ₃₁	32
24.	C-160 Sperm Oil Howe and French	3.7	Not Available	
25.	Starlight 125 Oil Sherwood Refinery	7.2	Not Available	
26.	Technical Butyl Stearate Arnold Hoffman	10.4	C ₄ H ₉ OCO (CH ₂) ₁₆ CH ₃	22

TABLE 3

SOME PHYSICAL CHARACTERISTICS (ADHESION AND FLEXIBILITY)
OF LUBRICANTS ON PARACHUTE SHROUDLINE

	<u>Physical Characteristics of Lubricated Line</u>	
	<u>Adhesion</u>	<u>Flexibility</u>
Alpha Corporation		
Molykote Type U	Very Poor	OK
Molykote Silicone Type M-77	Very Poor	OK
Alrose		
Nonisol 250	OK	OK
Nonisol 300	OK	OK
Alrosal	OK	OK
American Aniline and Extract Co.		
Orthonyl	OK	OK
Ortholube STS	OK	OK
Antara Chemicals		
Agent OC-O-151	OK/Fair	OK/Fair*
Prestabit Oil V	OK	OK
Monopol Oil 48	OK/Poor	OK/Poor
Soromine FW	OK	OK
Emulphor 719	OK	OK
Archer-Daniels-Midland Co.		
Spermafol 45	OK	OK
Spermoil 45 (Nat. Winter)	OK	OK
Spermoil 38 (Bleached Winter)	OK	OK
Cosmol 1000	OK	Fair
Liquid Cosmol	OK	OK

* Satisfactory at low percentage pickup, fair at higher percentage pickup.

Physical Characteristics of Lubricated Line

	<u>Adhesion</u>	<u>Flexibility</u>
Arkansas Co., Inc.		
Soluble Wool Oil	OK	OK
Arko Knitting Oil F	OK	OK
Arkoil Emulsion	OK	OK
Arkolube	OK	OK
Armour Chemical Division		
Neo Fat 140	OK	OK
Arquad 2HT	Poor	OK
Arquad 2C	OK	OK
Neo Fat 14	Very Poor	Very Poor
Armid 0	OK	OK
Armid 8	OK	OK
Ethomid HT/15	OK/Poor	OK/OK
Ethomid C/15	OK	OK
Ethomid RO/20	OK	OK
Ethomid HT/20	OK	OK
RD 1882	OK	OK
RD 1893	OK	OK
RD 1894	OK	OK
Neo Fat 94-04	OK	OK
Ethofat 60/60	OK	OK
Ethomeen T/60	OK	OK
Ethomeen 18/60	OK	OK
Ethofat 242/60	OK	OK
Ethomeen S-60	OK	Fair
Ethomid HT-60	OK	Fair
Ethomid RO/60	OK	OK
Arnold Hoffman Co.		
EC-203	OK	OK
Lissapol N-380	OK	OK
Ahco III Paste	Fair	Fair
Ahcovel E & F	OK	OK
Ahcotex W-100	OK	OK
Technical Butyl Stearate	OK	OK
Distilled Butyl Cellosolve Stearate	OK	OK
Distilled Butyl Stearate	OK	OK
Ahcovel R	OK	Fair
Ahcotex W-100	OK	OK
Lissapol N	OK	OK

Contrails
TABLE 3 - continued

<u>Physical Characteristics of Lubricated Line</u>		
	<u>Adhesion</u>	<u>Flexibility</u>
Atlas Powder Co.		
Pycal 60	Very Poor	Poor
G-263	OK	OK
G-1300	OK	OK
Tween 60	OK	OK
Tween 40	OK	OK
Tween 20	OK	OK
Span 40	OK	OK
G-3896	OK	OK
Baker Castor Oil Co.		
Calcium Ricinoleate	Very Poor	Very Poor
Barium Ricinoleate	Very Poor	Very Poor
Magnesium Ricinoleate	Poor	Poor
Flexricin 9	OK	OK
Flexricin 13	OK	Poor
Flexricin 15	OK	OK
Castorwax (Opalwax)	Fair	Poor
Bareco Oil Co.		
Victory Wax 155 Amber	Very Poor	Very Poor
Uetracera Amber	Very Poor	Very Poor
Victory Wax 165 Amber	Poor	Poor
Be Square Special Wax	Poor	Poor
Burkart Schier Co.		
Burkem 288-MO	OK	OK
Fibacon L	OK	OK
Synacol 305N	OK	OK
Creamsol Extra	Poor	OK
Burkschier Finish 100	OK	OK
Burkester R-1499	OK	OK
Parasol L-1379	OK	OK
Carbide & Carbon Chemicals		
Polypropylene Glycol (Carbowax) 150	OK	OK
Polypropylene Glycol (Carbowax) 425	OK	OK
Polypropylene Glycol (Carbowax) 1025	OK	OK
WADC TR 54-323 Pt. 1	66	

<u>Physical Characteristics of Lubricated Line</u>		
	<u>Adhesion</u>	<u>Flexibility</u>
Polypropylene Glycol (Carbowax) 2025	OK	OK
Polyethylene Glycol (Carbowax) 200	OK	OK
Polyethylene Glycol (Carbowax) 300	OK	OK
Polyethylene Glycol (Carbowax) 400	OK	OK
Polyethylene Glycol (Carbowax) 600	OK	OK
Polyethylene Glycol (Carbowax) 1000	OK	OK
Polyethylene Glycol (Carbowax) 1500	OK	OK
Polyethylene Glycol (Carbowax) 1540	OK	OK
Polyethylene Glycol (Carbowax) 4000	OK	OK
Polyethylene Glycol (Carbowax) 6000	Poor	OK
Ucon Lubricant 50-HB-2000	OK	OK
Ucon Lubricant LB-1145	OK	OK
Diethylene Glycol	OK	OK
Colloids Inc.		
Delectrol 374	OK	OK
Delectrol 379	OK	OK
Delectrol 376	OK	OK
Hygrolized Oil 220	OK	OK
Commercial Solvents Corp.		
Alkaterge C	OK	OK
Glucaterge R12	OK	OK
Glucaterge R28	OK	OK
Dexter Chemical Corp.		
Dextrol 986	OK	OK
Distillation Products Industries		
Myvacet 5-00	OK	OK
Myvacet 9-40	OK	OK
 WADC TR 54-323 Pt. 1	 67	

Contrails
TABLE 3 - continued

<u>Physical Characteristics of Lubricated Line</u>		
	<u>Adhesion</u>	<u>Flexibility</u>
Myverol 18-40	OK	OK
Myverol 18-05	OK	OK
Myverol 18-00	OK	OK
Dow Chemical Co.		
Polyglycol E 200	OK	OK
Polyglycol E 300	OK	OK
Polyglycol E 400	OK	OK
Polyglycol E 600	OK	OK
Polyglycol P 2000	OK	OK
Polyglycol P 3000	OK	OK
Polyglycol P 4000	OK	OK
Polyglycol E 600 Methyl Ether	OK	OK
Polyglycol P 600 Methyl Ether	OK	OK
Polyglycol P 600 X-Octyl Ether	OK	OK
Polyglycol E 600 X-Octyl Ether	OK	OK
Polyglycol 15-200	OK	OK
E. F. Drew Co.		
Drustat H	OK	OK
Drustat	OK	OK
Coronyl	OK	OK
Druspin A. D.	OK	OK
Soluble Luxolene	OK	OK
E. I. du Pont de Nemours		
Avitex R	Ok (Yellowing of line)	OK
Avitex C	Fair	OK
Avitone A	OK	OK
Avitone AL	OK	OK
Product BCO	OK	OK
Methacrol Lub C	OK	Fair
Methacrol Lub K	OK	Poor
Lorol 28	Poor	Poor
Ocenol	OK	OK
Lorol 5	OK	OK
Teflon	OK	OK
Emery Industries, Inc.		
Emery 2302	OK	OK
Emersol 233	OK	OK

<u>Physical Characteristics of Lubricated Line</u>		
	<u>Adhesion</u>	<u>Flexibility</u>
Emery 955	OK	OK
Emery 2230	OK	OK
General Electric Co.		
Fluid A & B	OK	OK
" C & D	OK	OK
E & F	OK	OK
G	OK	OK
H	OK	OK
I & J	OK	OK
Glyco Products Inc.		
Aquaresin	OK	Fair
Albacer	OK	Poor
Diglycol Oleate S	OK	OK
Acrawax C	Poor	Poor
Strobawax	Poor	OK
Diglycol Stearate	OK	OK
Acrawax B	OK	OK
Glyceryl Monolaurate	OK	OK
Glycowax S-932	Poor	Poor
Polyethylene Glycol 400 (Mono) Laurate	OK	OK
Flexowax C	Poor	OK
Glaurin	OK	OK
Ceramid	Poor	OK
Hercules Powder Co.		
Hercolyn	OK	Poor
Abitol	OK	Poor
Metalyn	OK	OK
Heyden Chemical Corp.		
Flexin P	OK	OK
Hooker Electrochemical Co.		
Fluorolube S	OK	OK
Fluorolube H. O.	OK	OK
Fluorolube M. G.	OK	OK

Contrails
TABLE 3 - continued

	<u>Physical Characteristics of Lubricated Line</u>	
	<u>Adhesion</u>	<u>Flexibility</u>
Howe and French Co. C-160 Sperm Oil	OK	OK
Jacques Wolf & Co. Monopol Oil	OK	OK
Masury Young Co. Scotch Nylon Compound 650	OK (Light Brown Color)	OK
Metheson Co. Ethyl Oleate	OK	OK
Minnesota Mining & Mfg. Co. F-126	OK	OK
Perfluorooctanoic Acid	OK	Poor
Perfluorodecanoic Acid	OK	OK
FC-8215	OK	Poor
FC-804	OK (Green Color)	Poor
Monsanto Chemical Co. Merlon BR	OK	OK
Nopco Chemical Co. Nopco IIII	OK	OK
Nopco RSF #7	OK	OK
Nopco RSF #15	OK	OK
Nopco C. P. Soluble	OK	OK
Nopco 2067-X	OK	Fair
Nopco 2152-X	OK	OK
Oronite Chemical Co. Dispersant Ni-W	OK	OK
Dispersant Ni-O	OK	OK
Polybutene No. 24	OK	OK
Polybutene No. 32	OK	OK
Polybutene No. 128	OK	OK
Petrolite Corp. Crown Wax 1035	OK	Fair
Crown Wax 700	OK	Fair
Crown Wax 500	OK	Fair
WADC TR 54-323 Pt. 1	70	

Contrails
TABLE 3 - continued

	<u>Physical Characteristics of Lubricated Line</u>	
	<u>Adhesion</u>	<u>Flexibility</u>
Rohm and Haas		
Rhotex 200	OK	OK
Triton K-60	Poor	OK
Sharples Chemical, Inc.		
Amyl Stearamide	Poor	OK
Sherwood Refinery Co.		
Amber Petrolatum	OK	OK
Starlight 125 Oil	OK	OK
Sherowax 40 Yellow	Tacky	OK
Sherolatum Red Veterinary	OK (Yellow Color)	OK
Stepan Chemical Co.		
Makanol #1	OK	OK
Makanol #2	Fair	OK
Synthetics Chemicals, Inc.		
Negamine 142A	OK (Yellow Line)	OK
Intracol R	OK (Yellow Line)	OK
Intracol O	OK (Yellow Line)	OK
Intracol OA	OK (Yellow Line)	OK
Intracol S	Not tested-Line stiff and harsh	
A. T. Thomas		
Ceresine-White-Ozokerite	OK	OK
Virginia-Carolina Chemical Corp.		
Dibutyl Butyl Phosphonate	OK	OK
Bis (2 ethylhexyl)2-ethylhexyl phosphonate	OK	OK

Contrails
TABLE 3 - concluded

Physical Characteristics of Lubricated Line

	<u>Adhesion</u>	<u>Flexibility</u>
Warwick Chemical Co.		
Warco 741A	Fair	Poor
Warco Wax #180 White	Fair	Poor
Mekon Y-20	Ok	Fair
Cardis #262	OK (Yellowing of Line)	Poor
Fortex	OK	Fair
Cardis #320	Ok (Yellowing of Line)	Fair
Warcosine	OK	OK
Wyandotte Chemical Corp.		
Pluronic L44	OK	OK
Pluronic L62	OK	OK
Pluronic L64	OK	OK
Pluronic F68	OK	OK
Pluronic L62 (Distearate)	OK	OK
Pluronic L64 (Distearate)	OK	OK
Chemically and Technically Pure Compounds		
Glycerine, U. S. P.	OK	OK
Palmitic Acid, C. P.	Poor	OK
Ricinoleic Acid, Tech.	OK	OK
Linoleic Acid, C. P.	OK	Fair
Oleic Acid, U. S. P.	OK	OK
Methyl Stearate, C. P.	Poor	OK
Dibutyl Phthalate, C. P.	OK	OK
Butyl Stearate	OK	OK
Spermaceti, U. S. P.	OK	OK
Cyclo Hexyl Maleate	Poor	OK
Caprylic Acid, C. P.	OK	OK
Caprie Acid, C. P.	OK	OK
Lauric Acid, C. P.	Poor	Poor
Myristic Acid, C. P.	Poor	Poor
Stearic Acid, C. P.	Poor	Poor
Dodecyl Alcohol, C. P.	OK	OK
Myristyl Alcohol, C. P.	OK	OK
1-Octadecanol, C. P.	Poor	Poor
Ethyl Laurate, C. P.	OK	OK
Ethyl Myristate, C. P.	OK	OK
Ethyl Stearate, C. P.	OK	OK
Sodium Oleate, Tech.	OK	Fair
Sodium Ricinoleate, Tech.	OK	Fair

TABLE 4

THE RESISTANCE TO FUSION OF SILICONE TREATED
AND UNTREATED TWILL CLOTH AND SCAURED LINE

$v = 75 \text{ ft/sec}$
 $\theta = 360^\circ$

$RH = 65\%$
 $T = 70^\circ\text{F}$

<u>Samples*</u>	<u>T₁, gm</u>	<u>T₂, gm</u>	<u>Remarks</u>
1a			All samples fused immediately
1b			
1c			
1d			
1e			
2a	22	100 to 115	Fusion after approx. 37 secs.
2b	22	90 to 115	Fusion after approx. 120 secs.
2c	22	85 to 110	Fusion after approx. 185 secs.
2d	22	95 to 115	Fusion after approx. 33 secs.
2e	22	95 to 120	Fusion after approx. 115 secs.
3a	22 32 42	90 to 96 118 to 120 145	Fusion after approx. 15 secs. at T ₁ of 42 grams.
3b	22 42	90 to 95 150 to 170	Fusion after approx. 7 secs. at T ₁ of 42 grams.
3c	22 32	90 to 100 130 to 140	Fusion after approx. 50 secs. at T ₁ of 32 grams
3d	22 32 42	90 to 91 125 to 136 156 to 152	Fusion after approx. 34 secs. at T ₁ of 42 grams
3e	22 32	98 to 101 136 to 150	Fusion after approx. 28 secs. at T ₁ of 32 grams.

- * 1. Untreated twill cloth, 1.6 oz., a through e - individual samples cut, equally spaced, from selvage to selvage over the entire length of cloth.
2. Silicone treated twill cloth, 1.6 oz., a through e - cut as in 1.
3. Silicone treated twill cloth, 0.9 oz., a through e - cut as in 1.

TABLE 5

A COMPARISON OF THE DATA OBTAINED
FROM LUBRICATING BOTH LINE AND CLOTH, AND LUBRICATING THE LINE ONLY

$v = 75 \text{ ft/sec}$ $\theta = 360^\circ$ $RH = 65\%$ $T = 70^\circ F$

		Cosmol 1000		Fluorolube HO	
		Both Line (%P = 5.0) and Cloth Lubricated	Line Lubricated (%P = 5.2) Cloth Scoured	Both Line (%P = 8.6) and Cloth Lubricated	Line Lubricated (%P = 8.6) Cloth Scoured
T_1 , gms	T_2 , gms	T_1 , gms	T_2 , gms	T_1 , gms	T_2 , gms
22	57	22**	70	89	Fusion
52	115		141		
102	219		253		
132	-		327		
142	-		Fusion		
152*	313				

* One sample fused after 22 sec., the other after 100 sec.
** One sample fused after 70 sec., the other at two minutes.

TABLE 6

A COMPARISON OF DATA OBTAINED FROM RUBBING LUBRICATED
CLOTH VS. SCOURED LINE, AND LUBRICATED LINE VS. SCOURED CLOTH

 $v = 75 \text{ ft/sec}$ $\theta = 360^\circ$

RH = 65%

T = 70°F

	<u>Scoured Line Lubricated Cloth*</u>		<u>Lubricated Line** Scoured Cloth</u>	
	<u>%P</u>	<u>F. L.</u>	<u>%P</u>	<u>F. L.</u>
Alkaterge C	8.9	152	8.6	202
Spermafol 45	8.8	162	11.1	202
Ceresine-White-Ozokerite	9.1	172	10.2	225

* Based on five samples.

** Based on two samples.

TABLE 7

THE EFFECT OF HEAT-OXIDATIVE TREATMENT AT 225°F
FOR 24 HOURS ON THE CLASSIFICATION OF CLASS IV LUBRICANTS

	<u>Before 225°F</u>		<u>After 24 Hours at 225°F</u>	
	<u>%P</u>	<u>Class</u>	<u>%P</u>	<u>Class</u>
1. Alkaterge C	10.5	IV	6.9	II
2. Arko Emulsion	11.4	III	9.5	I
3. Arko Knitting Oil F	9.9	II-III*	4.0	I
4. Ceresine-White-Czokerite	9.0	III	5.6	II-III
5. Distilled Butyl Cellosolve Stearate	9.1	III	0.9	I
6. Distilled Butyl Stearate	9.6	II-III	0	I
7. Emory 2302	7.8	II	0.9	I
8. Ethyl Oleate	8.4	I-II	0.2	I
9. Glaurin	8.9	III	3.0	II
10. Liquid Cosmol	9.9	IV	8.3	I-II
11. Methacrol Lub K	9.6	II-III	7.1	II
12. Myvacet 5-00	7.7	III	6.5	II-III
13. Myvacet 9-40	9.5	III-IV	7.4	II
14. Nopco 2152-X	8.0	II	5.2	I
15. Polyglycol E600 Methyl Ether	10.4	III	1.9	I
16. Polyglycol E600 X-Octyl Ether	9.5	II-III	1.7	I
17. Polyglycol P600 X-Octyl Ether	9.3	III	0.7	I

* One sample is Class II, the other is Class III.

Contrails
TABLE 7 - concluded

	<u>Before 225°F</u>		<u>After 24 Hours at 225°F</u>	
	<u>%P</u>	<u>Class</u>	<u>%P</u>	<u>Class</u>
18. Polyethylene Glycol 400	9.5	II-III	1.5	I
19. Polyethylene Glycol 400 (Mono) Laurate	10.2	II-III	4.5	I
20. RD 1882	8.1	III	2.1	I
21. Spermaceti	9.7	IV	9.0	III-IV
22. Spermafol 45	10.0	III-IV	8.8	III
23. Sperm Oil 45 (NW)	9.2	III	7.5	II
24. C-160 Sperm Oil	8.8	III	7.3	I
25. Starlight 125 Oil	9.0	II-III	1.6	I
26. Technical Butyl Stearate	8.9	II-III	0	I

TABLE 8

A LIST OF THE BEST LUBRICANTS AFTER HEAT-OXIDATIVE TREATMENT

	<u>After 225° F for 24 Hours</u>		<u>Before 225° F</u>		<u>After 225° F (24 Hours)</u>	
	<u>Flexibility</u>	<u>Adhesion</u>	<u>%P</u>	<u>Class</u>	<u>%P</u>	<u>Class</u>
1. Alkaterge C	OK	OK	10.5	IV	6.9	II
2. Ceresine-White-Ozokerite	OK	OK	9.0	III	5.6	II-III*
3. Glaurin	OK	OK	8.9	III	3.0	II
4. Liquid Cosmol	OK	OK	9.9	IV	8.3	I-II
5. Methacrol Lub K	Fair	OK	9.6	II-III	7.1	II
6. Myvacet 5-00	OK	OK	7.7	III	6.5	II-III
7. Myvacet 9-40	OK	OK	9.5	III-IV	7.4	II
8. Spermafol 45	OK	OK	10.0	III-IV	8.8	III
9. Sperm Oil (NW) 45	OK	OK	9.2	III	7.5	II
10. Spermaceti	OK	OK	9.7	IV	9.0	III-IV

* This notation indicates one sample is Class II, the other Class III.

THE EFFECT OF HEAT-OXIDATIVE TREATMENT AT 350°F
FOR ONE HOUR UPON THE CLASSIFICATION OF A LUBRICANT

	<u>Before 350° F</u>		<u>After 350° F (1 Hour)</u>	
	<u>%P</u>	<u>Class</u>	<u>%P</u>	<u>Class</u>
1. Alkaterge C	9.2	III	2.9	I-II*
2. Ceresine-White-Ozokerite	7.8	III-IV	1.5	I-II
3. Glaurin	10.0	IV	1.7	I-II
4. Liquid Cosmol	8.8	III-IV	5.7	I-II
5. Methacrol Lub K	9.1	II-III	3.8	I
6. Myvacet 5-00	9.4	III	2.9	I
7. Myvacet 9-40	9.8	III	3.3	I
8. Sperm Oil (NW) 45	9.8	III-IV	6.9	II
9. Spermaceti	9.0	III-IV	4.6	II
10. Spermafol 45	10.5	IV	7.5	III

* This notation indicates one sample is Class I, the other is Class II.

TABLE 10

THE EFFECT OF CLASS IV LUBRICANTS AND OF HEAT-OXIDATIVE TREATMENT
AT 225° F FOR 24 HOURS UPON THE BREAKING STRENGTH-ELONGATION OF NYLON SHROUD LINE

T = 225° F

	Unaged		Aged 24 Hours		Unaged		Aged 24 Hours		Remarks*
	%P	Strength Lbs.	%P	Elong. %	Strength Lbs.	Elong. %	Strength Lbs.	Elong. %	
1. Alkaterge C	10.5	562.7	7.0	40.7	559.3	41.3	559.3	41.3	Satisfactory
2. Ceresine-White-Ozokerite	9.0	566.0	5.6	42.0	474.7	39.3	474.7	39.3	Unsatisfactory
3. Glaurin	8.9	591.3	3.0	42.7	504.0	39.3	504.0	39.3	Unsatisfactory
4. Methacrol Lub K	9.6	588.0	7.1	46.0	518.7	42.7	518.7	42.7	Unsatisfactory
5. Myvacet 5-00	7.7	550	6.5	38.7	554.7	39.3	554.7	39.3	Satisfactory
6. Myvacet 9-40	9.5	584.7	7.4	44.7	458.7	36.7	458.7	36.7	Unsatisfactory
7. Liquid Cosmol	9.9	599.3	8.3	48.0	419.0	38.7	419.0	38.7	Unsatisfactory
8. Scoured Nylon Shroud Line	-	595.2	-	48.0	573.0	44.3	573.0	44.3	Unsatisfactory
9. Sperm Oil 45 (NW)	9.2	579.3	7.5	48.0	437.0	39.3	437.0	39.3	Unsatisfactory
10. Spermaceti	8.6	551.3	8.0	48.0	292.7	34.7	292.7	34.7	Unsatisfactory
11. Spermafal 45	10.0	555.3	8.8	43.3	435.0	40.0	435.0	40.0	Unsatisfactory

* Satisfactory if above 550 lbs. Unsatisfactory if below 550 lbs.

TABLE 11

THE EFFECT OF EXPOSURE FOR ONE HOUR AT 350° F ON THE PERCENTAGE PICKUP, BREAKING STRENGTH, AND ELONGATION OF LUBRICATED SHROUD LINE

T = 350° F

	Unaged		Aged 1 Hour		Before Aging		After Aging 1 Hour		Remarks*
	%P	Strength Lbs.	%P	Strength Lbs.	Strength Lbs.	Elong. %	Strength Lbs.	Elong. %	
1. Alkaterge C	9.2	606.7	2.9	606.7	48.0	29.3	308.7	29.3	Satisfactory
2. Ceresine-White-Ozokerite	7.8	554.0	1.5	554.0	42.7	24.7	177.3	24.7	Unsatisfactory
3. Glaurin	10.0	609.3	1.7	609.3	46.0	28.0	245.3	28.0	Satisfactory
4. Liquid Cosmol	8.8	586.7	5.7	586.7	47.3	28.0	246.7	28.0	Satisfactory
5. Methacrol Lub K	9.1	581.3	3.8	581.3	46.7	36.0	277.3	36.0	Satisfactory
6. Myvacet 5-00	9.4	566**	2.9	566**	42.7	25.3	214.7	25.3	Unsatisfactory
7. Myvacet 9-40	9.8	588	3.3	588	46.7	27.3	210.7	27.3	Unsatisfactory
8. Nylon Shroud Line, Scoured	--	595.2	--	595.2	48.0	30.0	247.3	30.0	---
9. Spermaceti	9.0	568.7	4.6	568.7	45.3	22.7	166.7	22.7	Unsatisfactory
10. Spermafol 45	10.5	542.0	7.5	542.0	42.7	24.7	194.0	24.7	Unsatisfactory
11. Sperm Oil (NW) 45	9.8	572.7	6.9	572.7	44.7	32.0	286.0	32.0	Satisfactory

* Satisfactory if above the breaking strength value of 247 lbs. for aged scoured line.

** Two samples

TABLE 12

THE EFFECT OF FUNGUS GROWTH ON AGED AND UNAGED LINES
AS MEASURED BY FUSION AND BREAKING STRENGTH TESTS

	Lubricated Line, Unaged			Lubricated Line, Aged			Amount of Fungus Growth		
	%P	Class	Strength Lbs.	%P	Class	Strength Lbs.	High	Moderate	Low
1. Alkaterge C	9.3	I	592.1	1.2	I	554.7	Unaged		Aged
2. Ceresine-White-Ozokerite	8.7	IV	523.3	4.5	II	449.3		Aged & Unaged	
3. Glaurin	9.0	I	421.3	2.8	I	476.0	Aged	Unaged	
4. Liquid Cosmol	10.0	III-IV*	554.7	8.0	I	579.3		Unaged	Aged
5. Methacrol Lub K	9.3	III	570.0	6.4	II	492.7		Aged & Unaged	
6. Myvacet 5-00	10.0	II-III	552.0	7.8	I	542.0	Unaged	Aged	
7. Myvacet 9-40	8.3	I-II	534.7	5.8	I	456.0		Aged & Unaged	
8. Spermaceti	9.0	III-IV	546.7	8.5	III-IV	435.3		Aged & Unaged	
9. Spermafol 45	9.2	III-IV	548.0	7.9	II	452.7		Aged & Unaged	
10. Sperm Oil (NW) 45	9.5	II-III	560.7	7.8	I	462.7		Aged & Unaged	

* This notation indicates one sample is Class III, the other Class IV.

THE EFFECT OF AGING FOR 24 HOURS
AT 225°F ON THE CLASSIFICATION OF LUBRICANTS

	<u>Before Aging</u>			<u>After Aging</u>		
	<u>%P</u>	<u>Class</u>	<u>B. S.*</u>	<u>%P</u>	<u>Class</u>	<u>B. S.</u>
Scoured Nylon Line			595.2			573.0
<u>Lubricated Line</u>						
1. Spermaceti	8.6	IV	530.8	8.0	III	292.7
2. Spermafol 45	10.0	III-IV	555.3	8.8	III	435.0
3. Ceresine-White Ozokerite	9.0	III	566.0	5.6	II-III**	474.7
4. Myvacet 5-00	7.7	III	550.0	6.5	II-III	554.7
5. Alkaterge C	10.5	IV	562.7	6.9	II	559.3
6. Myvacet 9-40	9.5	III-IV	584.7	7.4	II	458.7
7. Glaurin	8.9	III	591.3	3.0	II	504.0
8. Sperm Oil (NW) 45	9.2	III	579.3	7.5	II	437.0
9. Liquid Cosmol	9.9	IV	599.3	8.3	I-II	419.0
10. Methacrol Lub K	9.6	II-III	588.0	7.1	II	518.7

* Breaking Strength

** This notation indicates one sample is Class II, the other Class III.

THE EFFECT OF AGING FOR 24 HOURS AT 225°F
ON THE BREAKING STRENGTH OF NYLON PARACHUTE LINE

	<u>Breaking Strength (Lbs.)</u>		<u>Δ = B.A.*-A.A.**</u>
	<u>Before Aging</u>	<u>After Aging</u>	
1. Scoured Nylon Line	595.2	573.0	22.2
2. Alkaterge C	562.7	559.3	3.4
3. Myvacet 5-00	550.0	554.7	-4.7***
4. Methacrol Lub K	588.0	518.7	69.3
5. Glaurin	591.3	504.0	87.3
6. Ceresine-White-Ozokerite	566.0	474.7	91.3
7. Myvacet 9-40	584.7	458.7	126.0
8. Sperm Oil (NW) 45	579.3	437.0	142.3
9. Spermafol 45	555.3	435.0	120.3
10. Liquid Cosmol	599.3	419.0	180.3
11. Spermaceti	530.8	292.7	238.1

* Before Aging

** After Aging

*** This indicates a gain in strength

THE EFFECT OF FUNGUS GROWTH
ON THE CLASSIFICATION OF UNAGED LUBRICANTS

<u>Compound</u>	<u>Lubricated Line - Unaged</u>	
	<u>Unaged</u> <u>%P</u>	<u>After Fungus Exposure</u> <u>Class</u>
1. Ceresine-White-Ozokerite	8.7	IV
2. Liquid Cosmol	10.0	III-IV**
3. Spermaceti	9.0	III-IV
4. Spermafol 45	9.2	III-IV
5. Methacrol Lub K	9.3	III
6. Myvacet 5-00	10.0	II-III
7. Sperm Oil (NW) 45	9.5	II-III
8. Myvacet 9-40	8.3	I-II
9. Glaurin	9.0	I
10. Alkaterge C	9.3	I

* Breaking Strength

** This notation indicates one sample is Class III, the other Class IV.

THE EFFECT OF FUNGUS GROWTH
ON THE CLASSIFICATION OF AGED LUBRICANTS

<u>Compound</u>	<u>Lubricated Line After Aging (225°F)</u>		
	<u>After Aging</u> <u>%P</u>	<u>After Fungus Exposure</u> <u>Class</u>	<u>B. S. *</u>
1. Spermaceti	8.5	III-IV**	435.3
2. Methacrol Lub K	6.4	II	492.7
3. Spermafol 45	7.9	II	452.7
4. Alkaterge C	1.2	I	554.7
5. Myvacet 5-00	7.8	I	542.0
6. Glaurin	2.8	I	476.0
7. Sperm Oil (NW) 45	7.8	I	462.7
8. Myvacet 9-40	5.8	I	456.0
9. Ceresine-White-Ozokerite	4.5	II	449.3

* Breaking Strength

** This notation indicates one sample is Class III, the other Class IV.

Contrails
APPENDIX A

As previous work had been performed by E. I. du Pont de Nemours & Company, Inc. concerning the problem of line burns, this company was contacted to obtain any available information. Excellent cooperation in obtaining this information was extended to us by Mr. J. W. Berkeypile, Supervisor, Customer Service Laboratory, by supplying us with an adequate account of all their work and results. This information, consisting of copies of letters, is given in the following sections.

Contracts
E. I. DU PONT DE NEMOURS & COMPANY, INC.
Wilmington 98, Delaware

September 19, 1952

Dr. Chapin A. Harris
Project Principal
Lowell Textile Institute Research Foundation, Lowell, Mass.

Dear Dr. Harris:

Mr. Atwood has forwarded your letter of August 25 to us. We have looked back through our files and are summarizing below the somewhat limited information available on the work which was done to prevent fusing of parachute canopy fabric by friction between it and the shroud lines.

In all, some 150 different finishing materials were examined and it was found that paraffin wax and "Opalwax" were the most efficient in preventing friction between the fabric and the lines. Each of the candidates was evaluated for strength, elongation, flammability, shrinkage and ease of soiling in addition to the test for ease of melting. All of these tests indicated no significant differences in the properties of lines treated with the two successful candidates and the untreated lines in all properties except melting.

The equipment (see Fig. 1) used to evaluate the friction between the line and fabric was built from a Foster coner head. The traverse bar was attached through a lever system to an arm pivoted in the center and moving back and forth in a vertical plane. The sample to be tested was attached in the form of a V to the ends of this arm and at the apex the sample was put through a loop of canopy cloth folded double and held in place by a flat clamp. This clamp was attached to a square rod extending through square bearings to prevent twisting and then to a cord running over a pulley to a 1960 g. weight. The tester was run at a speed of 136 oscillations per minute, 14" of shroud line being run back and forth through the canopy cloth loop on each stroke of the traverse. The time for the shroud line to break through the canopy cloth was the measure of melt and abrasion resistance. The precision on untreated shroud line was of the order of 10%.

This test was used as a measure of the effectiveness of certain finishes to reduce damage to parachutes when the shroud lines are drawn rapidly over the canopy cloth. Inspection of parachutes damaged by malfunctioning during opening had revealed that the fabric had been melted in spots. Inspection of the fabric failed on this tester showed that melting had similarly occurred at the ends of the individual filaments and that the braided cover of the shroud line was fused. However, the individual filaments and the individual threads were not fused together to the extent present in fabric from damaged parachutes. This test did,

Dr. C. A. Harris

Contrails
-2-

September 19, 1952

therefore, include an abrasion component as well as the fusing component.

If, after looking this over, you have any specific questions, we will be glad to try and locate the answers to them. Most of this work was done 8 or 9 years ago and the people who worked on it have since been transferred to other locations.

Very truly yours,

SALES SERVICE DIVISION

signed/J. W. Berkeypile, Supervisor
Customer Service Laboratory

JWB:mec

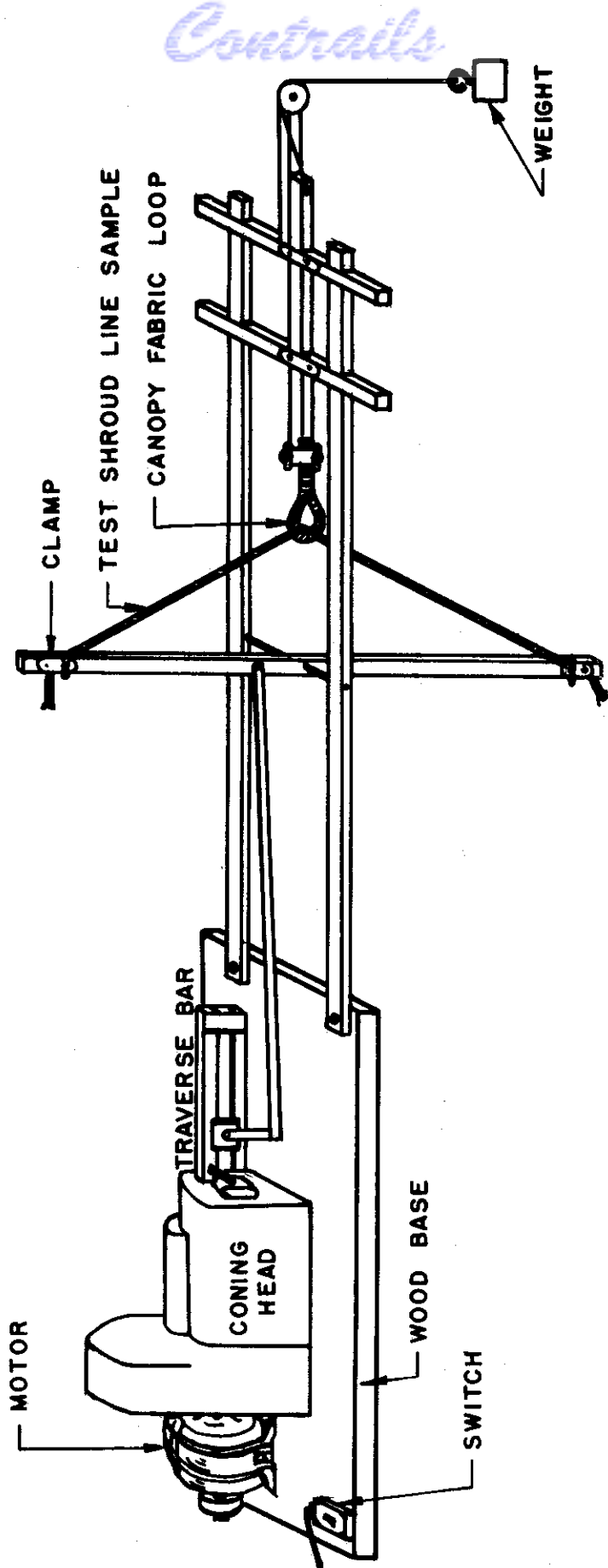

FIGURE 1. DU PONT DE NEMOURS FRICTION - FUSION TESTER



E. I. DU PONT DE NEMOURS & COMPANY, INC.
Wilmington 98, Delaware

October 8, 1952

Mr. Milton Boches
Lowell Textile Institute Research Foundation
Lowell, Massachusetts

Dear Mr. Boches:

In answer to your letter of September 24, all of our work on the fusing of parachute components was done on the shroud lines, since it appeared more practical to treat them than to treat the canopy cloth. The several lots of shroud line used in our tests gave values from 44 to 75 seconds without treatment, all against untreated commercial canopy cloth.

We have listed on the attached sheets most of the materials covered in our program. From the list of substances investigated, fifteen were chosen for further consideration. These were:

- potassium oleate
- "Stenol" (stearyl alcohol)
- N-amyl stearamide
- RH-81 (cyclohexanolamine stearate)
- RH-43 (abietyl alcohol)
- Rilan wax
- "Hallowax"
- petrolatum
- "Carbowax 1500"
- "Opalwax"
- ceresine
- cetyl alcohol
- RH-344 (acetylated abietyl alcohol)
- lead heptanoate
- paraffin

"Carbowax 1500" and potassium oleate proved to have too high water solubility. Cetyl alcohol increased the flammability to an undesirable degree. Petrolatum and RH-43 left the lines with a tacky, greasy surface. "Stenol" and Ceresine proved less effective than the others. "Hallowax" was questionable from a dermatitis standpoint, and N-amyl stearamide, RH-81, RH-344 and lead heptanoate were not available in commercial quantities, leaving "Opalwax" and paraffin as the best candidates at that time.

Mr. Milton Boches

Contrails

-2-

October 8, 1952

We trust that this is the information which you desire. If further questions occur to you during your work, we will be glad to try and answer them.

Very truly yours,

SALES SERVICE DIVISION

signed/ J. W. Berkeypile, Supervisor
Customer Service Laboratory

JWB/mec
Att.

WADC TR 54-323 Pt. 1

92

TREATMENT OF PARACHUTE SHROUD LINE

<u>Coating Substance</u>	<u>Source (if known)</u>	<u>Applied From</u>	<u>Characteristics</u>	<u>Time to Failure (sec)</u>
Ivory Soap	P. & G. Co.	Wet Smear	Slippery	208
Anhdrous Lanolin		Smear	Greasy	135
Graphite	Acheson #38	Dipped and rubbed		14
"Diolin"	du Pont Recrystallized	Hexane Mush	Somewhat stiff	182
"Diolin"	du Pont Recrystallized	2B Alcohol Solution	Smooth, not sticky	263
Butyl Palmitate		Dip	Oily, of course	268
Diglycol Stearate	Glyco Products	Hexane Soln.	Smooth, stiff	210
C ₁₈ Alcohol/C ₁₄ Alcohol (75:25)	Shell Development Company	MeOH Solution	Damp, not sticky	238
#3 Chalky Carnauba Wax	Chemical Dept. (Hoehn)	Hexane Solution	Adherence poor	162
Ketostearyl Alcohol	du Pont	MeOH Solution	Adherence poor	302
Amber Petrolatum	Sherwood Refinery	Smear	Greasy	396
Sorbitan Monostearate	Atlas, ARL-O-909		Stiff	250
"Duponol ME"		Water mush		117
Potassium Oleate	Eimer & Amend	Smear	Damp, not sticky	444
Castor Oil		Dip	Very wet	205

Contrails

TREATMENT OF PARACHUTE SHROUD LINE - continued

<u>Coating Substance</u>	<u>Source (if known)</u>	<u>Applied From</u>	<u>Characteristics</u>	<u>Time to Failure (sec)</u>
Cellulose Acetate	du Pont	Water soln.	Very stiff	352
"Carbowax 1500"		Water soln.	Fairly stiff	19
Boric Acid		Dip	Stiff	4
Butyl Acid Polysilicate		Hexane soln.	Adherence poor	269
Paraffin	Esso "Tavern"	Hexane soln.	Not sticky	117
Zinc Stearate		Hexane mush	Not sticky	142
Stearic Acid	Armour's "Neofat"	CCL ₄ soln.	Very stiff	34
Sodium Silicate	du Pont	Water soln.	Adherence poor	45
Aluminum Palmitate		CCL ₄ mush	Adherence poor	417
Rilan Wax	du Pont	CCL ₄ mush		
Lecithin	Wilson Labs. purified	Hexane soln.	Damp	188
"Potassium Palmolate R"	Glyco Products	Water emulsion	Damp	173
Aluminum Resinate		2B Alcohol mush	Very rough	18
Basic Ca Lignin Sulfate	Marathon	Water suspension	Very rough	6
"Acrax C"	Glyco Products	CCL ₄ soln.	Fairly stiff	263

TREATMENT OF PARACHUTE SHROUD LINE - continued

<u>Coating Substance</u>	<u>Source (if known)</u>	<u>Applied From</u>	<u>Characteristics</u>	<u>Time to Failure (sec)</u>
"Flexowax C"	Glyco Products	CCl ₄ soln.	Fairly stiff	315
"Stenol"	du Pont	2B alcohol soln.	Stiff	461
Hydrogenated China- wood Oil		CCl ₄ soln.	Adherence poor	115
Ethyl Cellulose		2B Alcohol soln.	Stiff	32
Type-6 Nylon		Isopropanol soln.	Stiff	49
Chloroparaffin	du Pont	CCl ₄ soln.	Stiff	232
"Cascolac 9228"	Casein Co. of America	Water	Stiff	266
Royce Resin		2B Alcohol soln.	Damp, sticky	305
Cetyl Betaine	du Pont	Dip	Stiff, damp, slick	334
Amyl Sillicate		Dip	Wet when warm	115
"Alkanol WXN"	du Pont	Dip		42
Orange Shellac		Benzene soln.		70
Agar-Agar				26
N-Butyl Lauramide	Sharples 4227	2B Alcohol soln.	OK	250
"Opalwax"	du Pont	CCl ₄ soln.	Stiff	363
Ceresine	A. H. Thomas	Hexane soln.	Not very stiff	373

TREATMENT OF PARACHUTE SHROUD LINE - continued

<u>Coating Substance</u>	<u>Source (if known)</u>	<u>Applied From</u>	<u>Characteristics</u>	<u>Time to Failure (sec)</u>
Montan Wax	"White-Ozokerite"	CCl ₄ soln.	Not very stiff	273
"Cascolac 9228/Sorbitol" (90:10)	Sorbitol from Atlas	Water soln.	Stiff	214
Sorbitol		Water soln.	Good	240
Cetyl Alcohol	du Pont	2B Alcohol soln.	Good	371
Bees Wax		Benzene	Med. stiff	300
"Crisco"	Proctor & Gamble	Smear	Greasy	147
Butyl-4-Keto Stearate		2B Alcohol soln.		265
Stearamide	du Pont	CCl ₄ soln.	Not very stiff	217
Butyl Stearate	Comm. Solvents	Dip	Oily	342
Amyl Oleate	Sharples Solv.	Dip	Oily	332
Calcium Resinate		Dry Dusted		5
Mannide Mono Oleate	Atlas	Dip	Oily	174
Ammonium Oleate	Eimer and Amend	Smear		170
"Alkanol WX"	du Pont	Dip	Damp	123
Bone Black	Fabricoid	Dry Dusted		4
Aluminum Oleate		Not soluble enough		

TREATMENT OF PARACHUTE SHROUD LINE -- continued

<u>Coating Substance</u>	<u>Source (if known)</u>	<u>Applied From</u>	<u>Characteristics</u>	<u>Time to Failure (sec)</u>
Calcium Stearate		CCl ₄ mush		82
Purified Talcum		Dry dust		8
Lead Oleate				157
Anthracene	C. P. Sublime	Benzene		28
Acenaphthene		2B Alcohol		21
Hydrogenated Castor Oil		CCl ₄ soln.		107
"RH-344"	du Pont	2B Alcohol soln.	Fairly stiff	369
"Aluminum Oilsolate"	Resinous Products	2B Alcohol soln.	Stiff	20
Lauric Dimer	RH-22	CCl ₄ soln.	Med. Stiff	226
"Avitex OB"		Smear		206
Ammonium Naphthenate		2B Alcohol soln.	Not stiff	217
Barium Benzyl Sulphonate	Berlin- Aldershof	Water		14
N-Amyl Stearamide	Sharples Solv.	2B Alcohol soln.	Med. stiff	474
Cashew Nut Oil		Dip	Very oily	57
Barium Oleate		CCl ₄ mush	Med. stiff	32

TREATMENT OF PARACHUTE SHROUD LINE - continued

Contrails

<u>Coating Substance</u>	<u>Source (if known)</u>	<u>Applied From</u>	<u>Characteristics</u>	<u>Time to Failure (sec)</u>
Acyl Urea from Coconut Oil		Benzene mush	Adherence poor	161
Ferrous Ricinoleate		2B Alcohol mush	Oily	262
C12 Saturated Alcohol	Shell Development	Dip		141
Diglycol Laurate	Glyco Products	Dip	Oily	268
Cobalt Linoleate		Benzene		56
N-Amyl Oleamide	Sharples Solv.	Dip	Oily	275
Ammonium Laurate	Glyco Products	Dip	Med. stiff	172
"Rhotex 200"	Rohm and Haas	Dip	Sticky	218
Powdered Chalk		Dry dusted		6
Sodium Benzene Sulphonate	Eimer and Amend	Water	Stiff, not adherent	14
Gum Shiraz	Thurston & Braidisch	Water	Not stiff	31
Stearyl (Oleyl) Diphthalate		Dip	Oily	270
Carbitol Ricinoleate	Glyco Products	Dip	Oily	198
Di-b-Naphthyl Ether		Acetone	Fairly stiff	324

TREATMENT OF PARACHUTE SHROUD LINE - continued

Contrails

<u>Coating Substance</u>	<u>Source (if known)</u>	<u>Applied From</u>	<u>Characteristics</u>	<u>Time to Failure (sec)</u>
Decalin		Dip		40
Diglycol Oleate		Dip	Oily	307
Copper Stearate		Hot Benzene	Slightly stiff	173
Sorbitol		Water dip		237
"Acimul"	Glyco Products	Benzene	Med. stiff	339
Wool Wax Alcohols	du Pont	2B Alcohol Alcohol	Sl. stiff, sl. tacky	223
"Daxad #11"	Dewey & Almy	Water	Stiff	8
Benzyl Stearate		2B Alcohol Alcohol	Slightly stiff	273
Mongli Wax		Benzene	Stiff	268
Balsan		Toluene	Very stiff	142
"Ammonium Linoleate R"	Glyco Products	2B Alcohol		142
"Ammonium Linoleate R"	Glyco Products	Paste		127
Gum Arabic		Water		13
Rilanit Wax		Benzene soln.	Fairly stiff	197
"Sunproof" Wax		Benzene soln.	Fairly stiff	316

TREATMENT OF PARACHUTE SHROUD LINE - continued

Contrails

<u>Coating Substance</u>	<u>Source (if known)</u>	<u>Applied From</u>	<u>Characteristics</u>	<u>Time to Failure (sec)</u>
"Aridex WP"	du Pont	Water	Very stiff	228
Graphite Flake	Dixon's Ticonderoga #2	CCl ₄ mush		9
"Avirol"		Water	Adherence not good	156
C ₁₄ Alcohol	du Pont	2B Alcohol	Adherence not good	120
C ₁₄ Alcohol	du Pont	2B Alcohol	Applied more Alc.	158
Ammonium Stearate Wax	Eimer and Amend	Hexane	Adherence poor	195
Carbitol Stearate		2B Alcohol	Adherence poor	219
"Carbowax 4000"		Water	Stiff	249
Ammonium Undecylenate	Naugatauk Chem.	40% paste	Damp	100
Stearic Anhydride		Ether	Very stiff	218
Zinc Oleate		Not easily soluble		
Lauryl Acid Succinate	du Pont	2B Alcohol	Adherence poor	110
Lead Keto Stearate		CHCl ₃ mush	Adherence poor	278
Lauramide		CCl ₄ mush	Adherence poor	140
Titanium Laurate		CHCl ₃ solution	Stiff	110

TREATMENT OF PARACHUTE SHROUD LINE - continued

<u>Coating Substance</u>	<u>Source (if known)</u>	<u>Applied From</u>	<u>Characteristics</u>	<u>Time to Failure (sec)</u>
"Cerese Wax AA"	Socony Vacuum	Hexane	Stiff	289
"Superla Wax Yellow"	Standard Oil of Ind.	Hexane	Stiff	268
Spermaceti Wax	Elmer and Amend	Ether	Stiff	232
Stearin		Ether	Stiff	227
Lead Heptanoate		CHCl ₃	Med. Stiff	379
"Aquaresin GB"	Glyco Products	Water		16
Low Vi. Black Wax	Pure Oil	CHCl ₃		103
"Glyco Wax B-430"	Glyco Products	Benzene	Stiff	244
Gelatine	Ucopco	Water	Very stiff	25
Bayberry Wax		Benzene	Stiff	235
Hydrogenated Ester Gum		2B Alcohol	Very stiff	37
Gum Mastic	A. H. Thomas	Benzene	Very stiff	135
"Dowicide A"	Dow Chemical	Water	Stiff	17
"Dowicide I"	Dow Chemical	MeOH	Very stiff	36
Glycerine		Dip	Wet	95
Ocenol		Dip	Wet	163

TREATMENT OF PARACHUTE SHROUD LINE -- concluded

<u>Coating Substance</u>	<u>Source (if known)</u>	<u>Applied From</u>	<u>Characteristics</u>	<u>Time to Failure (sec)</u>
Amo Wax (White 120)		Benzene	Greasy	259
"Halowax"		Benzene	Sl. Stiff, adherence NSG	444
Ozokerite		Benzene	Stiff	303
RH-81 (Cyclohexanol Amine Stearate)		2B Alcohol	Stiff	404 & 117
RH-43 (Abietyl Alcohol)		2B Alcohol	Tacky	540
Polydioxolane Stearate		2B Alcohol	Stiff	205
Polydioxolane Sebacate		2B Alcohol	Good	140
Diphenylol Propane		2B Alcohol	Very stiff	20

Contrails

Field Tests of Lubricated Parachutes

In 1945 at Fort Bragg, N. C., a total of 750 jumps were made with parachutes equipped with Opal Wax suspension lines, and were compared with 750 jumps made during the same period with parachutes having standard nylon suspension lines. All canopy or line damage attributable to the action of the suspension lines was recorded. Parachute jumps were made from C-47 airplanes flying at approximately 110 MPH indicated air speed and from an altitude of approximately 1000 feet. The results were reported as follows:

<u>Type of Parachute</u>	<u>No. of Jumps</u>	<u>Malfunction</u>	<u>Panel Sections Replaced</u>	<u>Lines Replaced</u>
Waxed line parachutes	750	19	84	7
Standard parachutes	750	24	134	13

The officer in charge of the jump reported that the waxed suspension lines reduced the frequency and amount of damage caused by malfunction. However, if one considers the number of panel sections and lines for each malfunction, the results obtained are as follows:

<u>Type of Parachute</u>	<u>Panel Sections Replaced per Malfunction</u>	<u>Line Replaced per Malfunction</u>
Waxed line parachute	4.4	0.37
Standard parachute	5.6	0.54

It would therefore appear that the results obtained from this field test are inconclusive; although it might be argued, especially from the results obtained for the panel sections, that the trend appears to favor the hypothesis that treated lines are better than untreated line parachutes.

No information was given as to the amount of lubricant used upon the field trial samples.

A copy of the original report is presented in the following sections.

Contrails
THE AIRBORNE BOARD
ARMY GROUND FORCES
Camp Mackall, North Carolina

452.161 - GNVBD

May 24, 1945

SUBJECT: Test of Parachutes with Experimental Suspension Lines,
Project No. 235

THRU: Commanding General, Airborne Center, Camp Mackall, N. C.

TO: Commanding General, Army Ground Forces, Army War College,
Washington 25, D. C.
ATTENTION: Requirements Section.

1. Authority

a. 2nd Indorsement, Headquarters Army Ground Forces, file 452.161 (15 Dec. 44) GNRQT-11/10122, dated 4 January 1945 to President, The Airborne Board, Camp Mackall, North Carolina through Commanding General, Airborne Center, Camp Mackall, North Carolina to letter Army Air Force, Air Technical Service Command, Wright Field, Dayton, Ohio, file TSEAL-5G, dated 15 December 1944, subject: "Request for Service Test by Parachute School, Fort Benning, Georgia", to Commanding General, Army Ground Forces, Army War College, Washington 25, D. C., through Commanding General, Army Air Forces, Washington, D. C. Attn: AC/AS, M&S, in which it was directed that The Airborne Board conduct the requested test and submit a report of test in thirty (30) days from receipt of material.

b. Letter, Headquarters Army Ground Forces, Army War College, Washington, 25, D. C., file 452.161 (27 Jan 45) GNRQT-11/ 13430, dated 27 January 1945, subject: "Request for Service Test by Parachute School, Fort Benning, Georgia" to President, The Airborne Board, Camp Mackall, North Carolina through Commanding General, Airborne Center, Camp Mackall, North Carolina, in which it was stated that the report of test would be submitted within sixty (60) days of receipt of material.

2. Factual Background

This project was initiated by the Air Technical Service Command due to high maintenance requirements on nylon parachutes. It was believed by the aforementioned agency that treatment of the nylon suspension lines with an emulsion of Opalwax would materially reduce the coefficient of friction and thus reduce the frequency and amount of damage caused by contact of suspension lines with the canopy.

3. Purpose of Test

To determine if the treatment of nylon suspension lines with an emulsion of Opalwax will reduce the incidence of parachute damage during opening.

4. Conclusions

The Airborne Board concurs in the conclusions as stated in paragraph 5 of the report of test.

5. Recommendations

It is recommended that:

a. Production of all troop type parachutes with nylon suspension lines include treatment of lines with an emulsion of Opalwax.

b. The possibility of treating the nylon lines of parachutes now in service, with an emulsion of Opalwax, be investigated and lines of these parachutes be so treated.

signed/CHESTER B. DEGAVRE
Colonel, Infantry
President

Continuity
THE AIRBORNE BOARD
ARMY GROUND FORCES
Camp Mackall, North Carolina

452.161 - GNVBD

17 May 1945

SUBJECT; Test of Parachutes with Experimental Suspension Lines,
Project No. 235.

To: The President, The Airborne Board, Camp Mackall, N. C.

1. Personnel

1st Lt. Robert L. Oakley of The Airborne Board conducted the test and prepared this report. He was assisted by Technical Sergeant John E. Borom, of The Parachute School, Fort Benning, Georgia. The parachute jumps made during this test were by students of The Parachute School.

2. Description of Materiel Tested

a. Fifty (50) Parachutes, Troop Type, T-7, with Opalwax treated suspension lines were furnished by the Parachute Branch, Personal Equipment Laboratory, Engineering Division, Air Technical Service Command, Wright Field, Dayton, Ohio.

b. The parachutes were manufactured by the Pioneer Parachute Company, Manchester, Connecticut.

c. The parachutes are T-7 nylon troop-type parachutes equipped with 550 lb. nylon O. D. suspension lines, Spec. AN-C-63a, Type III, manufactured by Cheney Brothers Manufacturers of Manchester, Connecticut and especially treated with an Opalwax emulsion developed by the E. I. du Pont de Nemours Company, Wilmington, Delaware.

d. Fifty (50) parachute assemblies, Troop Type, T-7 with standard nylon suspension lines were furnished by The Parachute School for comparison during tests.

3. Details of Tests and Results

a. Test No. 1

(1) Purpose:

To compare ease of stowing of waxed suspension lines with standard nylon suspension lines.

Contrails

- (2) Method:
Fifty (50) parachutes having wax treated suspension lines and fifty (50) parachutes having standard nylon suspension lines were packed by experienced qualified riggers. These parachutes were examined by the test officer and each rigger was questioned.
- (3) Results:
The waxed suspension lines were stowed as easily and accurately as standard nylon suspension lines.

b. Test No. 2.

- (1) Purpose:
To determine if the waxed line parachutes are satisfactory for personnel use with respect to strength and operation.
- (2) Method:
Thirty-five (35) parachutes having experimental suspension lines were dropped from C-47 airplanes flying at an indicated air speed of 160 MPH and at an altitude of approximately 500 feet. Each parachute carried a dummy load of 230 pounds.
- (3) Results:
All parachute openings were normal and no damage to lines or canopies of the parachutes was noted.

c. Test No. 3.

- (1) Purpose:
To determine if waxed suspension lines reduce the incident of parachute damage during opening.
- (2) Method:
A total of 750 jumps with parachutes equipped with waxed suspension lines were made and compared with 750 jumps made during the same period with parachutes having standard nylon suspension lines. All canopy or line damage attributable to the action of the suspension lines was recorded. Parachute jumps were made from C-47 airplanes flying at approximately 110 MPH indicated air speed and from an altitude of approximately 1000 feet.

Contrails

(3) Results:

<u>Type Parachute</u>	<u>No. of Jumps</u>	<u>Malfunction</u>	<u>Panel Sections Replaced</u>	<u>Lines Replaced</u>
Waxed line para- chutes	750	19	84	7
Standard para- chutes	750	24	134	13

4. Summary of Tests and Results

a. There was no apparent difference in the handling and stowing of the waxed suspension lines when compared with standard nylon suspension lines.

b. The strength of waxed suspension lines was at least equal to that of standard nylon suspension lines.

c. The waxed suspension lines did not affect the functioning of the parachute.

d. The waxed suspension lines reduced the frequency and amount of damage caused by malfunction.

5. Conclusions

Nylon troop type parachutes equipped with Opalwax Emulsion treated suspension lines should be considered by The Airborne Board for issue to airborne units.

signed/ROBERT L. OAKLEY
1st Lt., Infantry
Test Officer

Friction and Lubrication

A literature search of friction and lubrication in metallic and non-metallic materials (which included textile fibers, yarns, and fabrics) was made to obtain available theoretical and experimental information.

The study of the frictional properties of fabrics has received little attention in textile research (1, 2). Although some effort has been made to relate the hand of textiles to basic frictional phenomena (3), for the most part friction studies have been directed toward a better understanding of interfiber relationships rather than the behavior of the ultimate fabric (4, 5, 6, 7, 8). Fortunately, many of the basic concepts of friction, as evolved from a study of metallic and nonmetallic substances, can be applied toward a study of textile structures (9).

Many attempts have been made to understand static and kinetic friction and its causes from the very beginning of the scientific period to modern times. The work of DaVinci (1508), Amontons (1699), Coulomb (1785), Euler (1750), Morin (1831), and Bikerman (1941) led to the development of certain laws of friction. These laws, in the light of present day investigations, have been termed classical and are summarized as follows:

1. Frictional force is directly proportional to load, i.e., to the total force acting normal to the sliding surface.
2. Frictional force for a constant load is independent of the apparent Area of contact.
3. Frictional force for a constant load is independent of the velocity of sliding.
4. Frictional force depends upon the nature of the materials in contact.

Law number one is the well known law of Amontons which, expressed mathematically, is $\mu = \frac{F}{N}$, where μ is the coefficient of friction and is considered to be constant for a material, F is the frictional force and N is the load or total force acting normal to the sliding surfaces.

Recent investigations, however, have disclosed that these "classical" laws are not always valid, and according to Palmer (10) must be restated as follows:

1. Frictional force is independent of load.

Contrails

2. Frictional force is directly proportional to the actual area of contact.
3. Frictional force depends upon the velocity of sliding and in the higher range generally decreases with increasing velocity.

Thus the first three laws of friction have had to be considerably modified in order to account for recent experimental observations.

The mechanics of friction have only recently begun to be understood, and as yet our knowledge is far from complete. Again, according to Palmer, the phenomenon of friction has been attributed to such factors as:

1. The intermeshing of gross surface irregularities.
2. The action of molecular forces that may cause adhesion, cohesion, or local welding.
3. The plowing of harder projections through softer ones.
4. The action of electrostatic forces.

It is the belief of many authorities that all four of the mechanisms constitute the phenomena of friction, but the basic and most important cause is that which can be ascribed to the operation of molecular forces. It is obvious that the frictional process is complex, and that many further studies must be undertaken before an understanding of friction may be fully integrated into the main body of exact science.

Lubrication

Almost synonymous with friction is the problem of lubrication. Because of friction, energy and material losses occur, and any suitable substance which reduces these losses is termed a lubricant.

There are two basic divisions in friction (11). The first is dry friction in which there is no lubricant present and the approximate coefficient of friction is greater than 0.3. This is the most severe condition and seizing of the moving parts may occur, in addition to corrosion and high frictional and material losses.

The second division is that case where the rubbing surfaces are lubricated, and the coefficient of friction is less than 0.3. Energy and material losses are greatly lessened as a result of the lowering of the coefficient of friction and the protection afforded to the surfaces by the lubricant film.

The study of lubricated metallic friction has resulted in the discovery of two general types of lubrication (12). In the first type, which is called boundary lubrication, a molecular thickness of lubricant is present, and the

Contrails

coefficient of friction is between 0.1 and 0.3. The friction is influenced by the nature of the underlying surface as well as by the chemical constitution of the lubricant. The bulk viscosity plays little or no part in the frictional behavior.

The second type of lubrication is hydrodynamic or fluid film lubrication where the surfaces are separated by an appreciable thickness of lubricant. The resistance to motion is entirely due to the viscosity of the interposed layer, and the coefficient of friction is in the order of magnitude of .1 - 0.05.

It is difficult in practice to obtain fluid lubrication, especially if the speed of sliding is low or the load is high. Hence, boundary lubrication is of the greatest importance in engineering practice, and may for our particular problem also be of the greatest value.

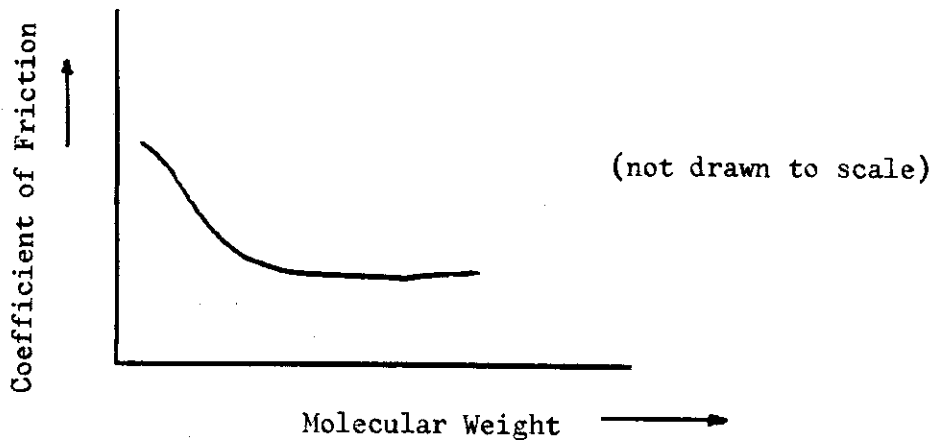

Figure 1*

* Bowden & Tabor, Friction and Lubrication of Solids, p. 179, Oxford University Press, New York (1950).

Contrails

The boundary lubricating properties of long-chain compounds have been investigated. Figure 1 illustrates the findings that the coefficient of friction will decrease and reaches a limiting value as the molecular weight increases (between 12 to 16 carbon atoms per chain length).

The effect of temperature upon the friction of boundary lubricated metallic surfaces has been studied, and data appear to indicate the friction of the sliding surfaces does not vary continuously with the temperature. At certain temperatures there is a sharp rise or transition in the friction to higher values. This relatively sudden change in the friction corresponds to the bulk melting point of the lubricant or of the chemical compound (metallic soap) formed between the lubricant and the metallic surface. It is clear that the main function of the lubricant film is to diminish the amount of intimate contact between the sliding surfaces. With hydrocarbon films the lateral contact is of the greatest importance in protecting the surfaces, for as the temperature increases, lateral cohesion is diminished and breakdown of the film becomes pronounced. With compounds capable of chemically reacting with the surface, the breakdown of the surface film does not occur at the melting point of the material but instead occurs at the melting point of the compound formed between the lubricant and the surface.

The wearing of lubricant layers is also important in boundary lubrication and is an index as to the effectiveness of a lubricant. A single molecular layer produces the same reduction in friction as a thick film but the monomolecular layer is worn away far more rapidly. Therefore, it was concluded that, as the thickness of the lubricant film increases, there is a gradual decrease in the rate at which this film wears off the surface. It is obvious that for adequate protection of the lubricated surface a sufficient amount of lubricant must be present.

Another important conclusion has resulted from boundary lubrication: that is, substances which give the same coefficient of friction are not necessarily equally efficient as lubricants. For instance, stearic acid and cholesterol both possess the same initial value for the coefficient of friction but after repeated slidings it is found that with cholesterol the lubricant film wears off more rapidly. Similar differences have been observed between the fatty acids. Results show that with monolayers of fatty acids there is a marked increase in the durability of the lubricant film with increasing chain length.

It appears on the basis of experimental data that in general the lubricating properties of boundary films are dependent upon the following factors:

1. The nature of the underlying surfaces.
2. The nature of the lubricant.
3. The quantity of lubricant present.

The influences of load and speed on the friction of boundary lubricated surfaces has been studied and, as this study is very pertinent to our work, will be considered in detail.

Controls

At high loads (500 to 6000 grams) frictional measurements show that Amontons' Law is accurately obeyed; as the load increases the whole friction process takes place on a proportionately increasing scale. At light loads (below 10 grams), when the penetration of the film may be avoided, the frictional force increases with decreasing load and therefore Amontons' Law is no longer valid.

The effect of low velocities (0.001 cm/sec to 2 cm/sec) upon frictional force has been shown to be negligible. However, if the speed of sliding is sufficient to initiate fluid lubrication, the coefficient of friction will decrease with increasing speed until at higher speeds the coefficient of friction may reach a fairly steady value.

Molecular forces, which operate only over a range of 10^{-8} to 10^{-7} cms, are believed to play a prominent role in the friction of "smooth" materials. It is, therefore, of interest to consider some conclusions resulting from a detailed consideration of this mechanism.*

When two smooth surfaces come together under load, contact occurs only at certain "high spots" or asperities in the surfaces. Because the pressure at these small areas is great, the elastic limit of the material is exceeded and plastic flow may occur at the points of contact. Plastic flow only ceases when the total sq. in. area of Contact A is represented by the equation

$$L = pA \quad (1)$$

where L is the load in pounds and p is the flow pressure of the metal which is about three times its ultimate tensile strength in lb per square inch. It has been found that the real area of contact is only a relatively small fraction of the apparent area of contact.

At these touching asperities welds, almost equal in strength to the bulk material, are formed at the surfaces in contact. These welds must be sheared off before sliding can occur, and the force to do this is the shear strength of the junction multiplied by A . The friction force F_m then becomes

$$F_m = As_m \quad (2)$$

Hence as

$$\mu = \frac{F}{L} = \frac{F_m}{L} = \frac{As_m}{pA} = \frac{s_m}{p} \quad (3)$$

* The main portion of this section of the appendix has been taken from E. Rabinowicz's article in Product Engineering, Vol. 25, p. 188-192, 1954, entitled "Solid Film Lubrication."

Since p and S_m are related properties of the same metal, their ratio will be of the same order of magnitude.

The application of a lubricant introduces an additional friction factor. (See Figures 2 and 3). If the lubricant has shear strength lower than that of the metal, the coefficient of friction will be reduced. Thus equation (1) becomes

$$F_1 = A [as_m + (1 - a)s_1] \tag{4}$$

Where a is the fraction of the real contacting area over which metal to metal contact exists. The reduction for very thin films becomes

$$\frac{F_1}{F_m} = a + (1 - a) \frac{s_1}{s_m} \tag{5}$$

The value of s , in equations (4) and (5) is the shear strength of the lubricant at the flow pressure of the metal, which is usually far greater than the shear strength at atmospheric pressure.

A lubricant is effective in reducing friction if it is able to achieve two conditions:

1. A small value of a , and
2. A low ratio of $\frac{s_1}{s_m}$

As a is a measure of the penetration of the lubricant film by the asperities the lubricant must adhere strongly to the surface and not flake off or wipe aside easily. To achieve a small ratio of $\frac{s_1}{s_m}$ (known as γ) the lubricant should be

much softer than the underlying surface.

It is of interest to consider the relationship between a and the wearing of a lubricated material. Metallic soaps often reduce a to as little as 1/750th and the wear to as little as 1/20,000th of the value for unlubricated surfaces. The friction, however, is reduced to only 1/14th, this being essentially the value of γ which is a function of shear.

Contacts

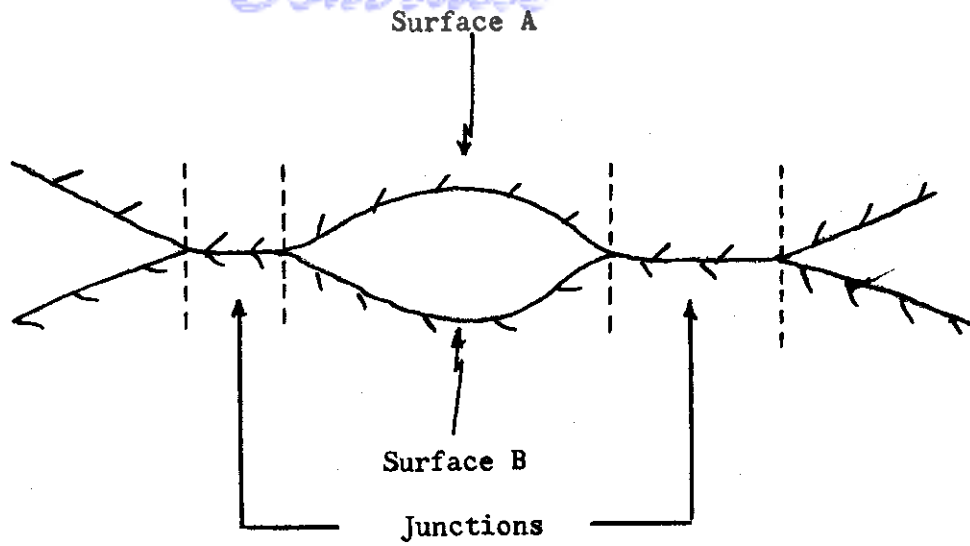

Figure 2

Conditions of Contact Between Metallic Surfaces

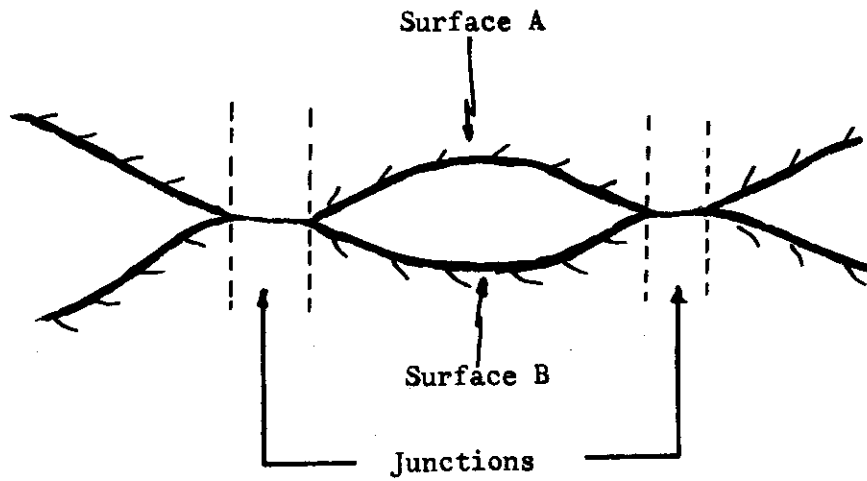

Figure 3

Conditions of Contact Between Lubricated Surfaces

Contrails

It should be noted that reduction of friction and reduction of wear do not necessarily go together. Friction is determined by two factors, α and γ , while wear is influenced by only one, namely $\alpha \frac{3}{2}$. For well lubricated surface,

α is much less than γ , indicating in this instance friction and wear are independent. However, for poorly lubricated surfaces when α is the main factor, friction and wear are closely related.

Soft metal films (e.g., thin lead film used in bearings of aircraft equipment) have found important uses in industrial applications. When the optimum film thickness is present, the values of α and γ can be made low (see Figure 4).

Soft metals lubricate well until their melting point is reached, and then fail.

Oils, greases, and soaps have been adopted for solid film usage as these materials strongly bond to metal surfaces by chemical forces reducing surface contact area. A resultant low value of the coefficient of friction occurs due to low shear strength of the lubricant. The ability to protect and lubricate a surface is a function of the polar and nonpolar components of the oily molecule, as most of these materials are long molecules with a long hydrocarbon chain (nonpolar) body and an active (polar), though small, head. The result may be firm, if not chemical, attachment to the surface resulting in a dense carpet of molecules extended at right angles to the lubricated surface. Synthetic lubricants such as silicones, fluorocarbons, polyalkylene glycols, etc., behave similar to natural substances. That is, because of the long chain and polar components, a relatively firm attachment occurs at the surface. As sliding speed increases, a softening results in the film. The actual area of contact may tend to increase, but the shear strength of the film decreases and usually the friction is lowered. When melting occurs, the lubricant film is easily wiped away, the actual area of contact increases sharply, and the friction once again reaches high values.

Heat of Friction

In addition to a consideration of the laws and understanding of friction per se, it is also necessary and important to our work to consider the fact that the work done in overcoming friction will appear as heat (14). The heat developed by friction between metallic surfaces will ordinarily be carried away by radiation, convection, and conduction; therefore, the temperature attained by sliding solids at fixed conditions of load and speed is dependent, among other things, upon the thermal conductivity of the materials. If the solid is a poor thermal conductor, as is true for textile materials, the frictional heat will not be quickly dissipated, and the surface temperature will attain a high value.

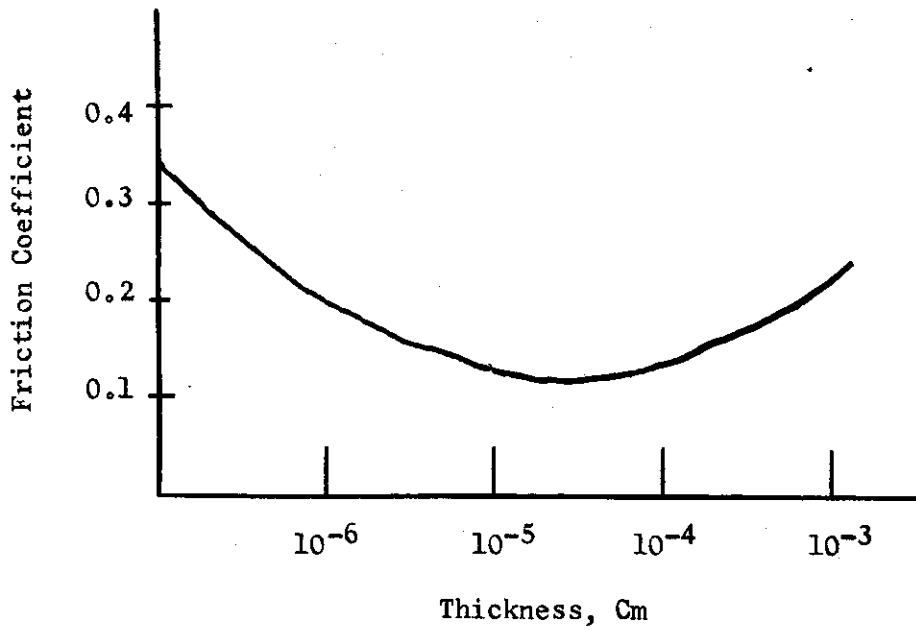

Figure 4

Friction Coefficient for Steel Rider Sliding Once Over Steel
as a Function of Thickness of the Medium Film Lubricant

An equation has been developed by Bowden and Tabor* based upon the apparent area of contact of a sliding cylinder in contact with a flat body. The equation is as follows:

$$T - T_0 = \frac{\alpha \mu W g v}{J \pi r} \sqrt{\left(\frac{1}{2 \sigma k r} \right)}$$

- μ = Coefficient of kinetic friction
- W = Load on the cylinder
- g = Constant of gravity
- J = Mechanical equivalent of heat
- k = Coefficient of thermal conductivity of cylinder
- σ = Cooling coefficient
- T = Temperature of emitting surface
- T_0 = Temperature of surroundings
- α = Fraction of heat going into top cylinder
- r = Radius of cylinder
- v = Velocity, cm per sec.

By inserting appropriate data into this equation, Bowden and Tabor calculated that the temperature rise of a constantan cylinder 1 mm. in diameter sliding over a steel surface with a velocity of 200 cm/sec is given by

$$T - T_0 \approx 200^\circ \text{ C}$$

However, as even with carefully prepared surfaces, the real area is only a small fraction of the apparent area of contact. The above calculation may be regarded as only a crude approximation and the true surface temperature must be considerably higher.

Experiments have been done relating surface temperature and thermal conductivity for cylinders of copper, nickel, lead, constantan, Wood's metal, and bismuth sliding on polished steel under identical conditions of load and speed. The rise in surface temperature is plotted against l in Figure 5.

* Material taken from Bowden and Tabor: The Friction and Lubrication of Solids, pp. 33-57, Oxford University Press, New York, 1950.

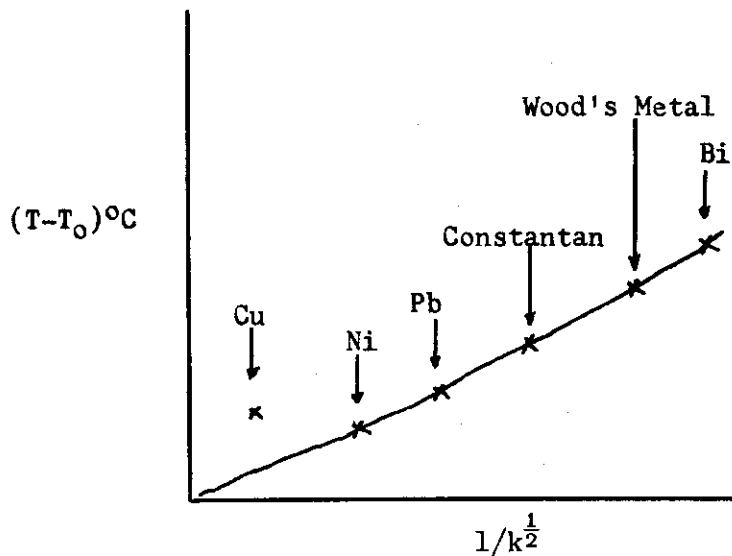

Figure 5

Temperature Rise of Rubbing Surfaces as a Function of Their Thermal Conductivity k (load 32 grams, sliding speed 20 cm/sec)

Contrails

Thus it is seen that bismuth, a poor thermal conductor, is at a level approximately five times as great as copper, which is a good conductor of heat. These results are of interest as they allow us to form some idea of the temperatures reached by nonconductors, such as glass ($k = 0.0017$), silk ($k = 0.0001$) or nylon (better than silk), as compared to surfaces which are better conductors.

Some experimental results indicate that for rubbing metals, transients or "hot spots" may be as high as 1000° C and approximately 10^{-4} seconds in duration. When metallic surfaces are lubricated (boundary), temperature transients are still observed, but the temperatures are somewhat reduced. There is strong evidence that this film of lubricant does not stay intact but is continually being destroyed and repaired during sliding. These high temperatures are attained across the layer of lubricant at points of intimate contact, and at such points marked deterioration occurs in the properties of the lubricant by means of volatilization and decomposition.

Obviously, for textile material, because of the high temperatures reached by sliding surfaces, heating of the surface may have a profound effect upon the physical and chemical condition not only of the surfaces but also of the bulk of the material. It is equally obvious that if an effective lubricating film is present such damage to the textile material could be minimized or prevented.

Consideration has been given to the influence of the size and shape of the slider upon the appearance of hot spots. For sliding surfaces the incidence of hot spots is determined primarily by the rate of liberation of frictional heat, that is by the product μWgv ; where μ is the coefficient of friction, W is the load, g is the constant of gravity, and v is velocity. According to Bowden and Tabor, "It (i.e., the rate of liberation of frictional heat) is not greatly influenced by the size and shape of the slider. If a large flat slider is used, the conditions of load and speed necessary are much the same as for a small curved one. The main difference is that with large flat surfaces the hot spots may be thinly distributed over a wide area instead of being concentrated into a smaller one. This is in harmony with the view that contact between the solids occurs only locally at the summit of the surface irregularities, so that the real area of contact is very small and bears little relation to the apparent area of the surfaces. It means that even with light loads the pressure at the points of real contact is high and it is just at these points that the rubbing and the liberation of frictional heat occurs. It is, of course, common knowledge that if the surfaces are rubbed hard enough they get hot, but a point brought out by these experiments is that the loads and speeds necessary to give detectable hot spots are very low. For example, with constantan sliding on glass with a load of about 1 kg, visible hot spots ($520-570^{\circ}$ C) can be seen when the sliding speed is as low as one or two feet per second. If the upper slider of metal is replaced by a poor conductor such as quartz ($k = 0.0035$), the hot spots may appear even more readily."

This would indicate that the melting point of a sliding object would be reached sooner, all other factors being kept constant, if a smaller slider is used. Such a consideration is of obvious importance to this study as the cylind-

rical line may be considered a slider possessing a small contact surface and because of this the hot spots produced are concentrated into a smaller area; hence, it would be expected that the attainment of the melting point of the nylon material will be more easily reached than if an oval or flat strip line were used.

Thus, both theory and experiment indicate that the high surface temperature produced by frictional heating increases with velocity and load. The surface temperature is also influenced by the thermal conductivity of the rubbing surfaces, and is a maximum if both of the surfaces have a low thermal conductivity. The limiting temperature is, in general, the melting point of the bodies. Even in the presence of lubricant films, high surface temperatures may be reached at small loads and speeds. It is believed that these high temperatures occur through the lubricant film at points of contact, and consequently may volatilize and decompose the lubricant at the very points where the surfaces are rubbing.

The heat effects of material rubbing on material have been considered previously. It is also of importance to this study to consider the available information in regard to the heat effects of fully lubricated surfaces. If one considers that a thick layer of lubricant is present on the nylon, thick enough to prevent contact between the two rubbing surfaces, we have in effect a fluid film condition. If this is so, then the ability of a finishing agent to lubricate is primarily determined by its viscosity. Viscosity is defined as the resistance of a liquid to flow by the equation

$$P = \eta \dot{\epsilon}$$

Where P is the shear stress (force per unit area), $\dot{\epsilon}$ the rate of change in velocity with distance from the wall (velocity gradient, strain rate, or rate of shear) t^{-1} , and η is the viscosity coefficient (usually called viscosity).

The amount of energy transformed into heat by viscous drag is given by

$$H = \eta \dot{\epsilon}^2$$

Bondi (15) states that "under ordinary conditions of viscometry where η is between 10^{-3} and 10^2 poise and $\dot{\epsilon}$ varies between 10 and $5 \times 10^2 \text{ sec}^{-1}$, the temperature increase within the flowing liquids is negligible. Under the conditions of high shear rate viscometry, where η is usually of the order of 10^{-1} to 10 poise and $\dot{\epsilon}$ varies between 10^4 and 10^6 sec^{-1} , the resultant temperature increase $\Delta T = \frac{H}{c\rho} = \frac{\Delta p}{c\rho}$ is by no means negligible. Where ΔT is the change in temperature, c is the specific heat of the liquid, Δp is change in pressure, H is the heat capacity, and ρ is the density of the liquid.

"A growing interest in the determination of the dependence of viscosity on rate of shear has been manifested recently. This interest has its origin in the increasing application of high polymer solutions as lubricants, and in the realization that many lubricants may show a lower viscosity under the high velocity gradients which prevail in bearings than under the conditions of ordinary viscometry...."

Contrails

Factors which affect the observed viscosity are temperature increase, "structural breakdown," and flow orientation (on a molecular scale). In order to arrive at valid conclusions concerning the last two factors, it is necessary to find a mathematical method which will allow estimation of the heat effect.

Only a few analytical and experimental attempts have been made for the case of heat effects in capillary flow. For the case of isothermal flow, no satisfactory solution of the obstinate differential heat balance has been formulated. Phillipoff, however, derived for adiabatic flow the formula

$$\frac{\eta}{\eta_0} = e^{-\beta \Delta p / \rho c}$$

when η is the apparent viscosity of the fluid flowing under the influence of the pressure differential Δp , β is its compressibility, η_0 is its viscosity at low flow rates, ρ is its density, C is its specific heat, and e is the base of the Napierian logarithm. The flow is not all adiabatic and it has been found that the above equation overcompensates slightly. Hersey and Zimmer have found that the observed temperature increase and viscosity decrease (of nonorienting fluids) are usually somewhat less than predicted by the equation of Phillipoff. From the work of these two experimenters, some conclusions may be drawn concerning the heat effects of inner friction and are as follows:

1. If the rate of shear is high, the temperature increase of the oil is also high.
2. If the rate of shear decreases, the tendency of the fluid to decrease in viscosity is also lowered.
3. With an increase in temperature, a corresponding decrease in viscosity occurs.

Thermal Properties of Textile Materials

In relation to our program, the thermal properties of fiber and fabric are of paramount importance. A search of the literature disclosed some information of value toward an understanding of the process of fusion. From a physical viewpoint, fusion involves the absorption of heat, as a result of the friction phenomenon, by the material, with a resultant rise in temperature. If the temperature rise is sufficiently high melting or decomposition of the material will eventually occur.

Absorption of heat and rise in temperature are related to several factors; such as, specific heat, thermal conductivity, heat of fusion, emissivity of the surface, and nature of the surface of the material. Obviously, some of these factors apply to the fibers only, whereas others will apply to both fiber and fabric.

Contrails

The specific heat capacity of most textile fibers is about 0.3 calories per gram per °C, and therefore should have little if any bearing on the heat insulation properties of textile fabrics. Nylon has an average heat capacity* of 0.555 between 20° C and 250° C, and hence has a value somewhat higher than that of the average textile fiber. Nylon also has a heat of fusion* of 22 calories per gram. These properties are undoubtedly of significance in the resistance of nylon to fusion; i.e., higher heat capacity would indicate a greater resistance of the nylon toward reaching its melting point; a moderately high heat of fusion also would be valuable in this respect.

Kaswell (16) states that "little data are available on the thermal conductivity of fibers because it is an accepted fact that the thermal insulation ability of a textile fabric is substantially independent of this inherent property. Rather, it is a function of the state of aggregation of the fibers in the textile structure. Cassie** states that the heat insulation of a fabric comes from the air entrapped in it." From the work done by Cassie it is shown that the conductivity of wool fibers is ten times that of air, silk is fifteen times that of air, plant fibers thirty times; with synthetic fibers acting more like plant fibers than protein fibers.

Some of the properties and factors which influence the thermal behavior of textile fabrics are:

1. Thermal conductivity - which is a function of the thickness of the fabric and is independent of the thermal insulation ability of the fiber per se.
2. Air velocity - the greater the air velocity through a fabric the poorer is its thermal insulation.
3. Nature of the fabric surface - smooth surface fabrics have high emissive power (radiation effects).

Therefore, it would appear that the nylon parachute (porous, thin, and smooth-surfaced) possesses more or less optimum qualities insofar as thermal properties are concerned; the only drawback to the use of nylon being its low melting point.

* du Pont Nylon Technical Service Bulletin.

** Cassie, A. B. D., Natural Fibres vs Man Made Fibres, J. T. I., 37, 556, (1946).

Contrails

The Laws of Friction and Lubrication in Textile Materials

Only within the past twenty years have studies been made to determine whether or not the classical or modern laws of friction apply to textile materials. At this date the information is far too scanty to allow for anything but general conclusions, which are often controversial, concerning the mechanisms involved between the rubbing of textile fibers, yarns and fabrics.

Friction may be studied either by an investigation of the forces operating between two rubbing flat surfaces, or between two curved surfaces. The first manner of rubbing employs in its study an experimental determination of the normal force and the frictional force. From these data the coefficient of friction may be calculated. This method of investigating fiber and yarn friction, for obvious reasons is not a very practical one, and has been little used in textile studies.

The second method employs the use of the so-called belt friction principle in which tension rather than load is used to obtain the coefficient of friction. The belt-friction principle has especially been used in fiber and yarn friction research.

In the use of the belt friction formula* where

$$\frac{T_1}{T_2} = e^{\mu \theta} \quad (1)$$

it is assumed that the string or cord is inextensible, which is not true for textile materials, and that the limiting frictional force F over any element of the cylinder, is related to the normal force R by Amontons' Law $F = \mu R$. Thus equation 1 contains the constant μ which is the coefficient of friction of the materials under study. At first sight this equation apparently offers a convenient method for the determination of the coefficient of friction of textile materials, for all fibers are strand- or rope-like and are flexible enough to be wound around a cylinder. Many investigators have initially used this relationship in obtaining the coefficient of friction. It was soon found that equation 1 is not exact for these materials, since $\frac{T_1}{T_2}$ is not constant but rather is a

function of T_1 . The relationship $\mu = A - B \log T_1$ where A and B are constants was discovered to be empirically more exact (Martino and Mittleman (1946), Breazeale (1947)).

At the present time, it is generally believed that the linear relation between F and R should be replaced by the relation

* See page 21 for a definition of each symbol.

Contrails

$$F = \alpha R^n \quad (2)$$

where n and α are dependent upon the material. For perfectly elastic solids in contact n is equal to 0.67, and for perfectly plastic solids, n is equal to 1.0. Only if n is equal to one is Amontons' Law valid, and for textile materials as n is always less than one, Amontons' Law will not be applicable. Howell in 1953, using the relationship $F = \alpha R^n$, derived a general form of the cylinder friction equation, which was successfully applied to data obtained from wool and rayon (17). This equation is as follows:

$$\frac{T_1}{T_2} = e^{\alpha \left(\frac{\rho}{T_1} \right)^{1-n} \theta} \quad (3)$$

T_1 = slack tension

T_2 = tight tension

α = constant (if $n = 1$, α is usual coefficient of friction)

n = constant, friction index

ρ = radius of cylinder

θ = angle of wrap

The ratio $\frac{T_1}{T_2}$ is no longer constant but, it is seen, depends upon the slack tension,

T_1 and also upon the radius of the cylinder, ρ .

An intelligent use of the simple belt friction formula requires the knowledge that the coefficient of friction calculated on the basis of this equation will not be an absolute value, but will only be a relative indication of the ratio of $\frac{T_1}{T_2}$, and is so used in this program.

$\frac{T_1}{T_2}$

The lubrication of textile fibers, yarns, and fabrics has received some attention in textile research. The excellent papers of Moss (18) and Röder (19) are of recent origin. Moss studied the lubrication of cotton and other textiles at a velocity of 3 ft. sec⁻¹, upon the Morrow friction tester which is based on the $e^{\mu \theta}$ law. He found that the coefficient of well-scoured cotton against mild steel before the addition of any lubricant is greater than 0.6; with the addi-

tion of small amounts of lubricant (0.1%) the coefficient of friction decreases to lower values (0.15-0.30). There does not seem to be any general relation, Moss states, between the lubricating effect and the chemical constitution. However, he is of the opinion that a relation may exist between the lubricating effect and some physical property of the lubricant at the high temperatures of the rubbing surfaces.

In Table 1 is presented a complete list of lubricants studied by Moss. Paraffin wax and methyl stearate and methyl oleate are best in their ability to lower the coefficient of friction while castor oil, sodium stearate, sodium oleate, and sodium ricinoleate were poorest and therefore, according to Moss, "the firm attachment of the lubricant to the surface by a polar group is not necessarily a requirement of a good lubricant. The double bond in the carbon chain seems to have little effect, for there is little difference between the minimum coefficients of friction reached with stearic acid and oleic acid or with their derivatives, although larger additions of oleic acid and the oleates are required to produce the lowest values. An hydroxyl group attached part way along the carbon chain in addition to a double bond as in ricinoleic acid and castor oil does reduce the lubricating effect which may also be important."

Within particular classes of compounds certain regular changes in lubricating effects are noted. For the fatty alcohols the coefficient of friction increases from 0.12 for lauryl (C₁₂) alcohol to 0.26 for octadecyl (C₁₈) alcohol, while the least addition in percentage decreases from 2.0 for lauryl alcohol to 0.1 for octadecyl alcohol. The same trend is observed for the methyl, ethyl, butyl, and cyclohexyl esters of oleic acid. In addition the coefficient of friction at a constant percentage of 0.1% was studied for lauryl, myristyl, cetyl, and octadecyl alcohols and the values were found to be 0.29, 0.26, 0.24, and 0.26, respectively. Moss does not venture any explanation for these results.

Values obtained in this study are taken from friction vs. addition curves of which the following Figure 6 shows typical examples.

Moss also observed that "the quantity of lubricant required to produce the lowest value of the coefficient depends to some extent on the distribution of the lubricant. Thus a surface coating of a solid lubricant, for example paraffin wax, produces the maximum decrease at a smaller addition than does penetrative addition, for example in a solvent, where the lubricant is spread throughout the yarn. On the other hand, there is little difference between the effects of additions made from solvents or emulsions or even as an undiluted liquid."

Röder, also using the $e^{-\mu}$ law, found that, as ethylene oxide groups were increased in stearyl alcohol from four to fifteen, the coefficient of sliding friction of viscose staple fibers at a speed of 90 cm per minute increased from 0.160 to 0.178 at a percentage pickup of 0.2; the same general effect was noted for stearic amide.

TABLE 1

LUBRICATING EFFECTS OF SUBSTANCES ON COTTON

<u>Lubricant</u>	<u>Lowest Value of Cotton Against Steel</u>	<u>Least Addition % to Produce Lowest Value</u>
Paraffin Wax	0.14	0.7
Mineral Oil	0.22	0.3
Octadecyl Alcohol	0.26	0.1
Stearic Acid	0.20	0.4
Oleic Acid	0.20	1.0
Ricinoleic Acid	0.29	0.15
Methyl Stearate	0.15	0.3
Methyl Oleate	0.14	1.5
Tallow	0.23	0.5
Castor Oil	0.35	0.2
Sperm Oil	0.20	1.0
Sodium Stearate	0.25	Less than 0.1
Sodium Oleate	0.26	0.15
Sodium Ricinoleate (castor oil soap)	0.33	3.0

TABLE 2

REGULAR CHANGES IN LUBRICATING PROPERTIES

<u>Lubricant</u>	<u>Lowest Value of Cotton Against Steel</u>	<u>Least Addition % to Produce Lowest Value</u>
Lauryl Alcohol, C ₁₂	0.12	2.0
Myristyl Alcohol, C ₁₄	0.17	1.5
Cetyl Alcohol, C ₁₆	0.20	0.25
Octadecyl Alcohol, C ₁₈	0.26	0.1
Methyl Oleate	0.14	1.5
Ethyl Oleate	0.16	1.0
Butyl Oleate	0.19	2.0
Cyclohexyl Oleate	0.23	0.5

Contrails

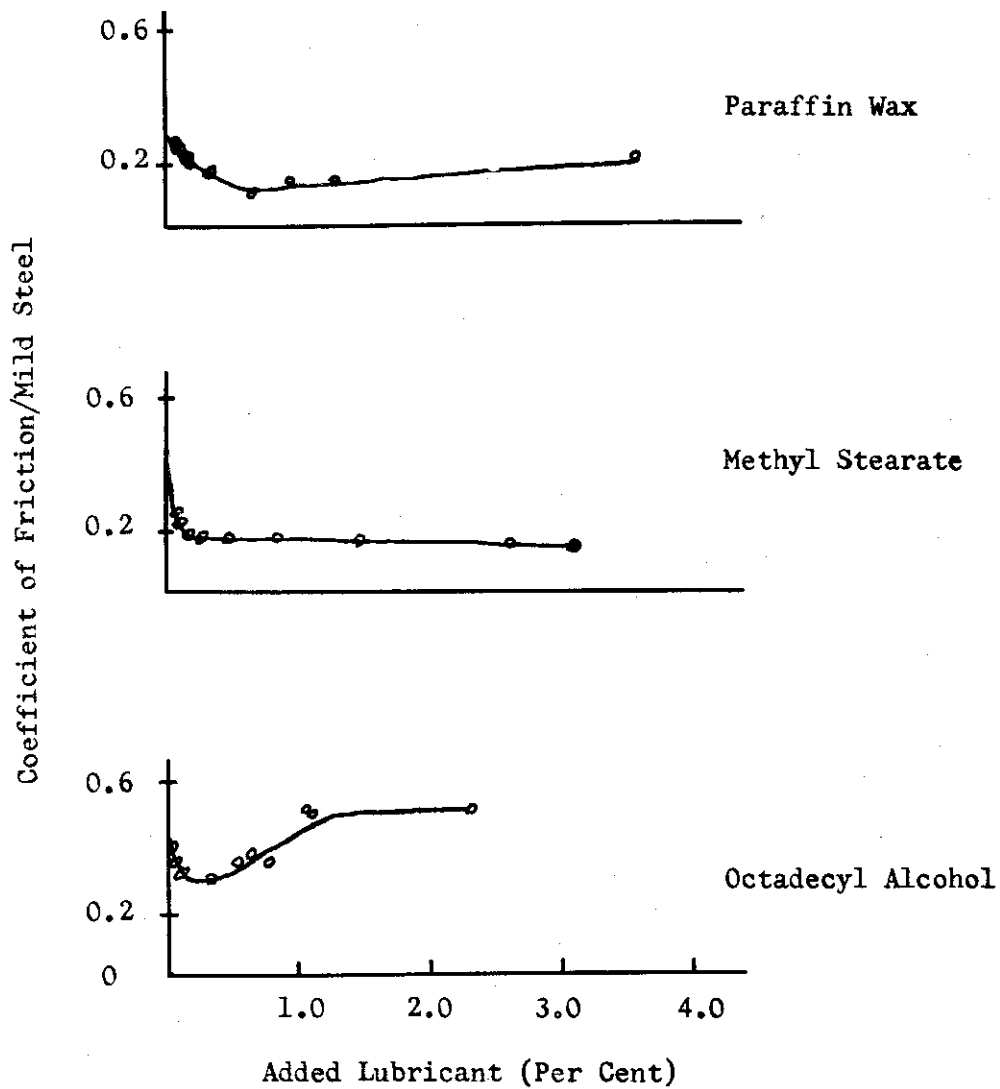

Figure 6

Effect of Lubricants on Frictional Properties of Well Scoured Cotton

Contrails

The amount of finish present is of importance in respect to the coefficient of sliding friction and when oily substances are present the frictional resistance of fibers generally first diminishes upon addition of a small amount of oil, passes through a minimum and then usually increases upon further application of oil.

The relationship of slack tension to the coefficient of friction was studied. The sliding coefficient of friction decreases as the slack tension increases; with an increase in speed an increase of the coefficient of friction is noted for both scoured and lubricated surfaces.

Of importance is the effect of relative humidity upon frictional force. The effect of relative humidity has been found negligible up to values of 70 per cent; however, once past this point the coefficient of sliding friction for scoured and lubricated surfaces greatly increases.

Röder studied various types of lubricants in relation to frictional force. A classification of finishing agents is presented based upon the type of surface active agent used. Three groups, classified by the differences between static and kinetic friction, are presented. Röder found that nonionic substances fell in Group I, anionics in II and cationics into III. Röder was successful in relating the groups to the handle of the fiber; Group I agents were generally scroopy, Group II were very slippery, whereas Group III were extremely slippery and possessed a "soft" handle.

The effect of increasing amounts of finishing agents of Group I, II, and III upon the coefficients of friction was determined. With finishing agents of Group I and II, both coefficients of friction decrease to a certain limit with the amount of finish applied; the agents of Group III, however, exhibit a steadily decreasing static coefficient of friction but the dynamic coefficient decreases to a certain point only and then remains constant. Röder claims that "this behavior points to a completely different mechanism of interfiber friction with the cationic type of finishing agents compared with the other types."

Belt Friction*

In Figure 1 is shown a belt or cord in contact with a rough, circular cylinder along a right section of its surface. Denote by T_1 and T_2 the tensions in the belt, T_2 being the greater. Let the belt be on the point of slipping to the right (in the direction of T_2). Let α be the angle subtended at the center of the section by the arc of contact, and let ϕ_m be the angle of friction.

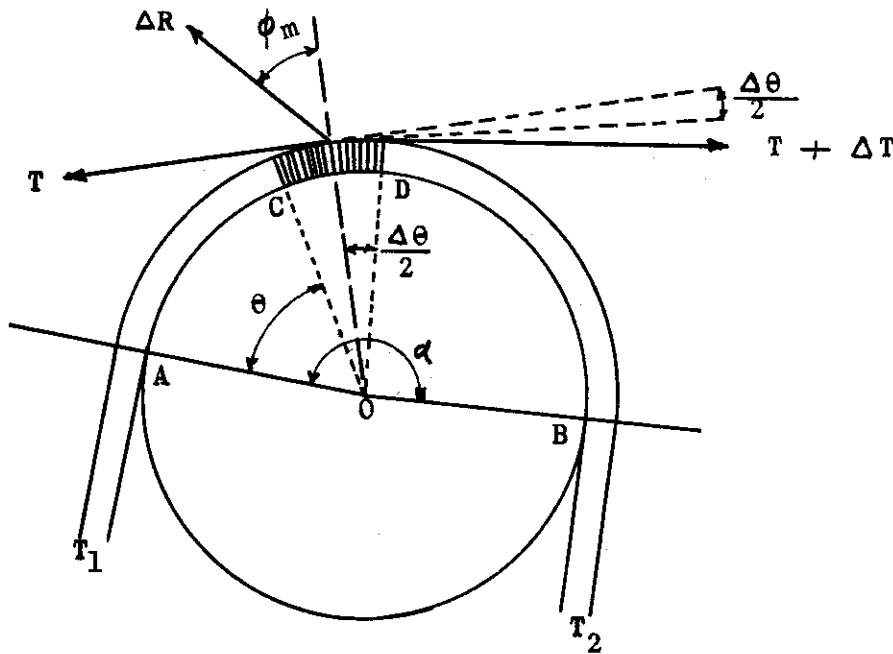

Figure 1

The Forces Acting on a Cord Wrapped around a Cylinder

The element CD of the belt is in equilibrium under three forces: the tension T at its left extremity, the tension $T + \Delta T$ at its right extremity, and the reaction ΔR of the cylinder on the element. The reaction ΔR makes the angle ϕ_m with the normal to the surfaces in contact. If $\Delta\theta$ is the angle subtended by CD , the angle between T and $T + \Delta T$ is $\Delta\theta$. From Lami's theorem we have

* Clements, G. R., and Wilson, L. T., Analytical and Applied Mechanics, pp. 73-74, McGraw Hill Book Co., Inc., New York, 1935.

Contrails

$$\frac{T}{\cos(\phi_m + 1/2 \Delta \theta)} = \frac{T + \Delta T}{\cos(\phi_m - 1/2 \Delta \theta)}$$

Therefore

$$T \left[\cos(\phi_m - 1/2 \Delta \theta) - \cos(\phi_m + 1/2 \Delta \theta) \right] = \Delta T \cos(\phi_m + 1/2 \Delta \theta),$$

whence

$$\Delta T = T \frac{2 \sin \phi_m \sin 1/2 \Delta \theta}{\cos(\phi_m + 1/2 \Delta \theta)}$$

and

$$\frac{\Delta T}{\Delta \theta} = \frac{T \sin \phi_m}{\cos(\phi_m + 1/2 \Delta \theta)} \frac{\sin 1/2 \Delta \theta}{1/2 \Delta \theta}$$

Then

$$\frac{dT}{d\theta} = \lim_{\Delta \theta \rightarrow 0} \frac{\Delta T}{\Delta \theta} = T \tan \phi_m = fT,$$

where f is the coefficient of static friction between the belt and the cylinder.

Separating the variables and integrating between corresponding limits for T and θ , we have

$$\int_{T_1}^{T_2} \frac{dT}{T} = f \int_0^{\alpha} d\theta ; \ln \frac{T_2}{T_1} = f \alpha$$

whence

$$T_2 = T_1 e^{f \alpha}$$

The angle α must be expressed in radians; and $e = 2.718\dots$, the base of natural logarithms.

The shapes of the curves obtained from test runs were not all alike. Information is presented in the following sections which will justify our selection of the minimum force reading for use in obtaining frictional data.

The force-time curves obtained with this apparatus appear to be divided into two general shapes characterized by the slack tension utilized. The first type of curve is illustrated in Figure 1 and is the type that generally occurs with low (12 grams) slack tensions.

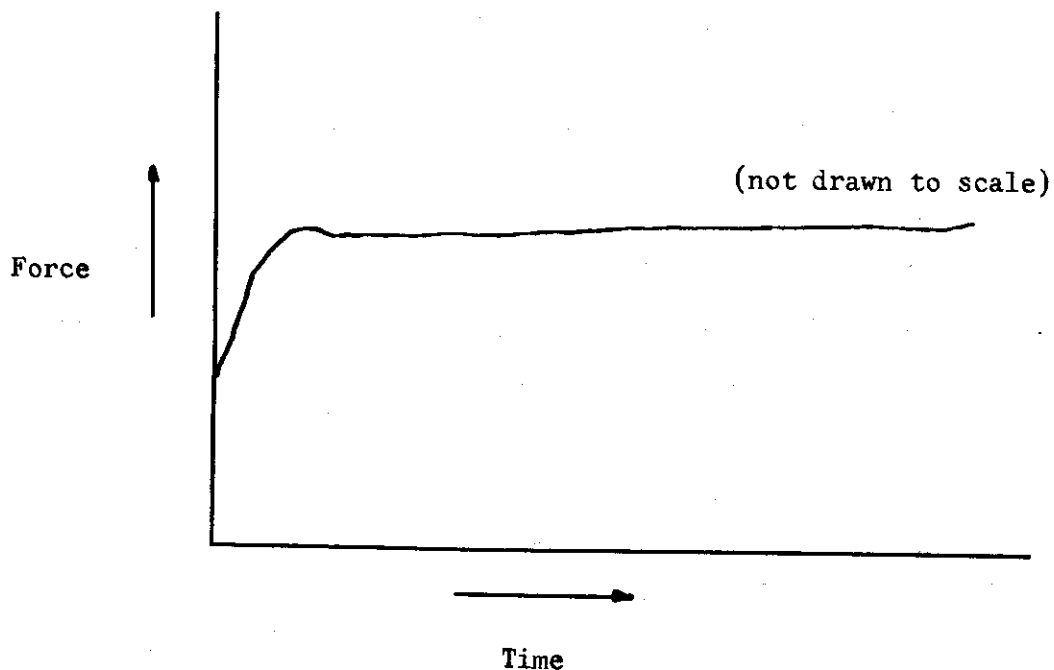

Figure 1

It is observed that no maximum peak is attained, and over the time interval studied, the forces of friction are essentially constant.

Contrails

The second type of curve is obtained with higher slack tensions, i.e., 20 grams and above. This curve is shown in Figure 2.

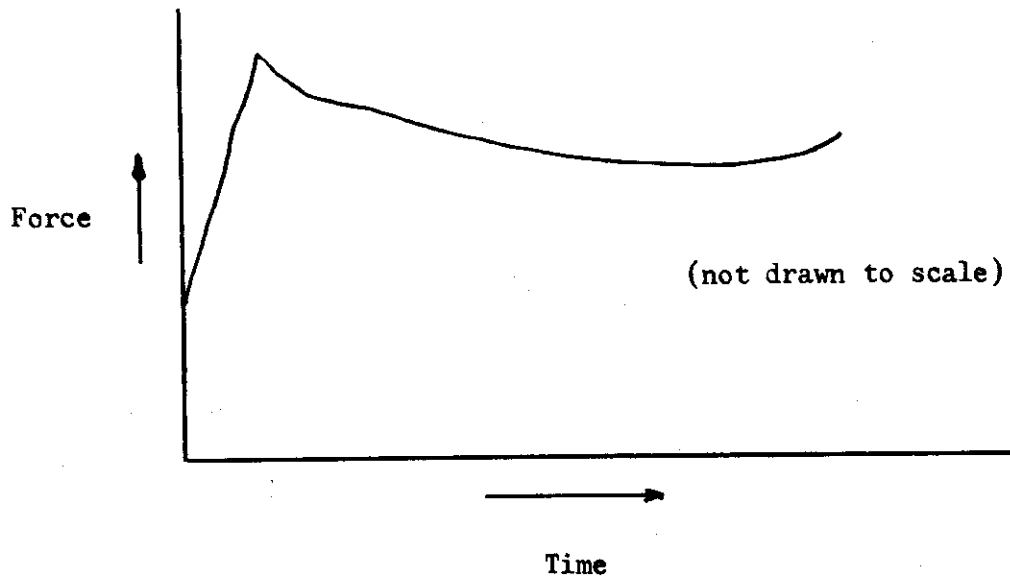

Figure 2

One observes with this type of curve that a peak in the frictional force is present at time approximately equal to zero. After this peak is reached, the frictional force decreases quite rapidly to a minimum value. Variations in the frictional force often result over the 1.5 minute interval which was used as the standard time of running.

Contrails

In the study of the scoured cloth and line at higher slack tensions, it was observed that a curve was obtained of the following type:

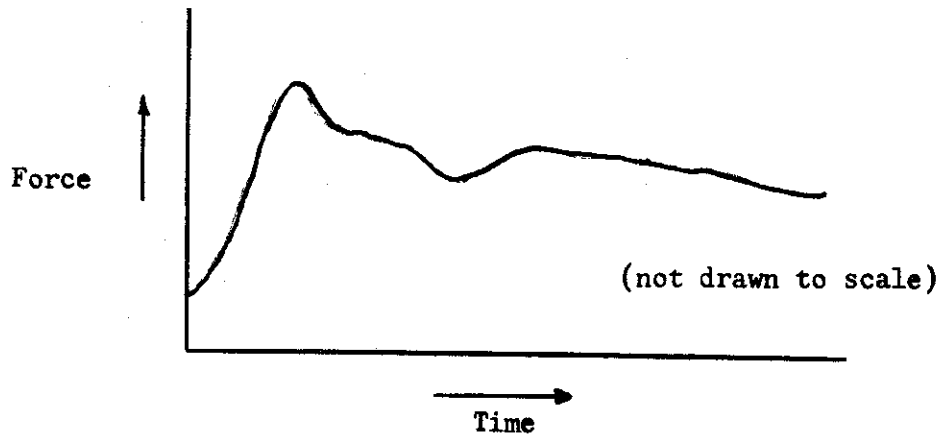

Figure 3

Under the same conditions the type of curve shown in Figure 4 was also observed:

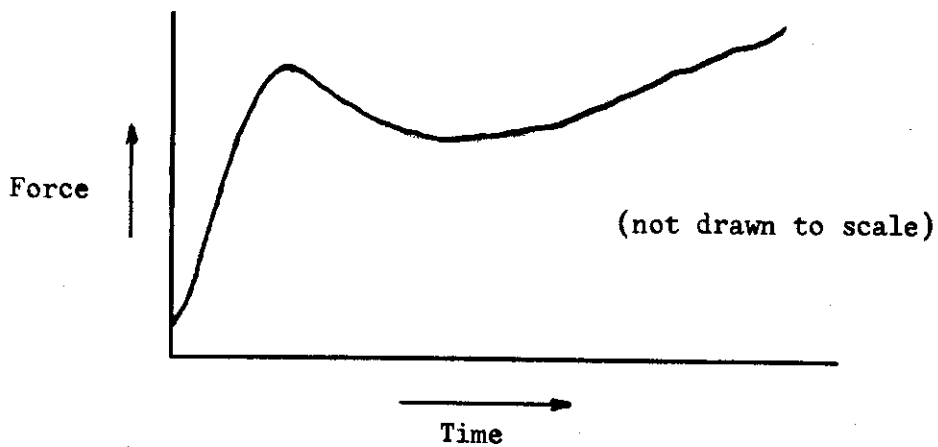

Figure 4

Contrails

In the case of the first curve (Figure 2), the curve reaches a maximum peak and then declines to a minimum value, but in the decaying process it may undergo relatively large fluctuations in frictional force. With the second type of curve (Figure 4), a maximum peak is reached initially followed by a drop, and then a marked and continued rise in the frictional force is noted. Lastly, in the investigation of lubricants, another type of curve was observed and is illustrated in Figure 5:

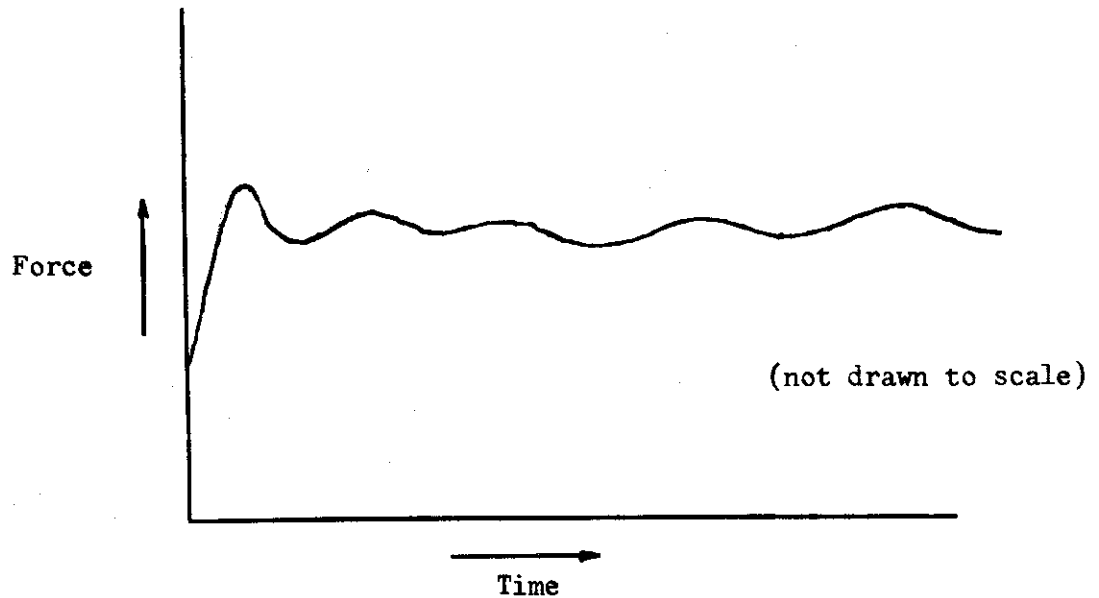

Figure 5

This curve consists of a maximum peak followed by a periodic variation in the frictional force over the entire time interval used. The peaks obtained after the maximum peak are always lower than the maximum peak itself.

Contrails

It was, therefore, decided early in our investigation that, since a minimum drop* in frictional force always occurs, this minimum would be used as the standard for the measurement of frictional force. This, of course, is not entirely satisfactory as a time relationship also exists which may be of significance. That is, the drop in frictional force to a minimum value does not necessarily occur in the same time interval for each sample studied. However, this time variation may for the present be overlooked, as the results are sufficiently reproducible upon the rather arbitrary basis of minimum frictional force.

* In the case of the type of curve which has no peak, the flat portion of the curve is taken as a minimum.

CONCERNS SUPPLYING LUBRICANTS

Alpha Corporation	Greenwich, Conn.
Alrose Chemical Co.	Providence, R. I.
American Aniline and Extract Co.	Philadelphia, Pa.
American Cyanamid Co.	New York, New York
Antara Chemicals	New York, New York
Archer-Daniels-Midland Co.	Cleveland, Ohio
Arkansas Company, Inc.	Newark, N. J.
Armour Chemical Division	Chicago, Ill.
Arnold, Hoffman and Co.	Providence, R. I.
Atlas Powder Co.	Wilmington, Del.
Baker Castor Oil Co.	New York, New York
Bareco Oil Co.	Philadelphia, Pa.
Burkart-Schier Chemical Co.	Chattanooga, Tenn.
Carbide and Carbon Chemicals Co.	New York, New York
Colloids, Inc.	Newark, N. J.
Commercial Solvents Corporation	New York, New York
Dexter Chemical Corp.	New York, New York
Distillation Products Industries	Rochester, New York
Dow Chemical Co.	Midland, Mich.
E. F. Drew Co.	New York, New York
du Pont de Nemours Corp.	Wilmington, Del.
Emery Industries, Inc.	Cincinnati, Ohio
General Electric Co.	Waterford, New York
Glyco Products, Inc.	Brooklyn, New York
Halocarbon Products Corp.	North Bergen, New Jersey
Hercules Powder Co.	Wilmington, Del.
Heyden Chemical Corp.	New York, New York
Hooker Electrochemical Co.	Niagara Falls, New York
Howe and French Co.	Boston, Mass.
Jacques Wolf & Co.	Passaic, New Jersey
Masury-Young Co.	Boston, Mass.
Minnesota Mining and Manufacturing Co.	Minneapolis, Minn.
Monsanto Chemical Co.	Everett, Mass.

Contrails

Nopco Chemical Co.

Harrison, New Jersey

Oronite Chemical Co.

New York, New York

Petrolite Corp.
Proctor and Gamble Co.

New York, New York
Cincinnati, Ohio

Rohm and Haas

Philadelphia, Pa.

Sharples Chemical, Inc.
Sherwood Refinery Co.
Standard Chemical Products
Stepan Chemicals Co.
Synthetic Chemicals, Inc.

Philadelphia, Pa.
Englewood, New Jersey
Hoboken, New Jersey
Chicago, Illinois
Paterson, New Jersey

A. H. Thomas Co.

Philadelphia, Pa.

Virginia-Carolina Chemical Corp.

Richmond, Va.

Warwick Chemical Co.
Wyandotte Chemical Corp.

Wood River Junction, R. I.
Wyandotte, Mich.

THE EFFECT OF THE SOLUTION CONCENTRATION OF THE LUBRICANT
AND TIME OF IMMERSION OF THE PARACHUTE LINE ON PERCENTAGE PICKUP

As a result of an investigation conducted on the effect of solution concentration and time of immersion upon percentage of the scoured line, it was found that time of immersion was a negligible factor upon the amount of lubricant deposited on the line (see Table 1). The concentration of the solution used, however, was significant and showed that the percentage pickup is directly proportional to the solution concentration. The time of immersion generally used was set at a minimum of ten minutes.

Contrails

TABLE 1

THE RELATIONSHIP OF SOLUTION CONCENTRATION AND TIME OF IMMERSION TO PERCENTAGE PICKUP

Compound	Concentration of Solution												Solvent		
	7 Per Cent By Weight				15 Per Cent By Weight				25 Per Cent By Weight						
	Immersion Time (min)		%P	%P	Immersion Time (min)		%P	%P	Immersion Time (min)		%P	%P			
G-3896 (nonionic)	5	30	4.5		5.5	5.5	13.2		14.0	13.5	5		30	60	5
Tween 60 (nonionic)	5	30	2.0	2.1	1.5	4.0	3.4	4.0	7.3	6.9	8.5	23.0	23.0	23.3	Water
Aerotex Softener H (cationic and anionic mixture)	5	30	2.5	2.5	2.5	4.0	5.3	6.9	11.8	11.9	11.9	12.3	11.4	12.2	Water
Prestabit Oil V (anionic)	5	30	5.2	5.5	5.5	6.4	6.3	6.9	12.3	11.4	12.2	12.3	11.4	12.2	Acetone
Arquad 2HT (cationic)	5	30	7.1	7.1	7.1	7.1	7.1	7.1	7.1	7.1	7.1	7.1	7.1	7.1	Ethanol
Ca Ricinoleate (polar)	5	30	5.9	5.9	5.9	5.9	5.9	5.9	5.9	5.9	5.9	5.9	5.9	5.9	Acetone

* %P = Percentage Pickup