

Unclassified

SECURITY CLASSIFICATION OF THIS PAGE (When Data Entered)

REPORT DOCUMENTATION PAGE		READ INSTRUCTIONS BEFORE COMPLETING FORM																				
1. REPORT NUMBER AFFDL-TR-78-115, Volume I	2. GOVT ACCESSION NO.	3. RECIPIENT'S CATALOG NUMBER																				
4. TITLE (and Subtitle) ANALYSIS OF DIGITAL FLIGHT CONTROL SYSTEMS WITH FLYING QUALITIES APPLICATIONS Volume I: Executive Summary	5. TYPE OF REPORT & PERIOD COVERED Final Report																					
	6. PERFORMING ORG. REPORT NUMBER TR-1101-1																					
7. AUTHOR(s) Richard F. Whitbeck	8. CONTRACT OR GRANT NUMBER(s) F33615-77-C-3026																					
9. PERFORMING ORGANIZATION NAME AND ADDRESS Systems Technology, Inc. 13766 South Hawthorne Boulevard Hawthorne, California 90250	10. PROGRAM ELEMENT, PROJECT, TASK AREA & WORK UNIT NUMBERS Program Element 61102F, Project 2307, Mechanics, Task 03, Flight Control Res																					
11. CONTROLLING OFFICE NAME AND ADDRESS Air Force Flight Dynamics Laboratory Air Force Systems Command Wright-Patterson Air Force Base, Ohio 45433	12. REPORT DATE September 1978																					
	13. NUMBER OF PAGES																					
14. MONITORING AGENCY NAME & ADDRESS (if different from Controlling Office)	15. SECURITY CLASS. (of this report) Unclassified																					
	15a. DECLASSIFICATION/DOWNGRADING SCHEDULE																					
16. DISTRIBUTION STATEMENT (of this Report) Approved for public release; distribution unlimited.																						
17. DISTRIBUTION STATEMENT (of the abstract entered in Block 20, if different from Report)																						
18. SUPPLEMENTARY NOTES																						
19. KEY WORDS (Continue on reverse side if necessary and identify by block number)																						
<table style="width: 100%; border: none;"> <tr> <td>Digital Control Systems</td> <td>Frequency Response</td> <td>Inter-Sample Ripple</td> <td>Servo Analy-</td> </tr> <tr> <td>Sampled Data</td> <td>Switch Decomposition</td> <td>Computational Delays</td> <td>sis</td> </tr> <tr> <td>z-Transforms</td> <td>Closed-Loop Systems</td> <td>Flying Qualities</td> <td>Closed-Loop</td> </tr> <tr> <td>w-Domain</td> <td>Linear Systems</td> <td>Tustin Transform</td> <td>Analysis</td> </tr> <tr> <td>Multi-Rate Sampling</td> <td>Data Holds</td> <td>Alias Response</td> <td>Root Locus</td> </tr> </table>			Digital Control Systems	Frequency Response	Inter-Sample Ripple	Servo Analy-	Sampled Data	Switch Decomposition	Computational Delays	sis	z-Transforms	Closed-Loop Systems	Flying Qualities	Closed-Loop	w-Domain	Linear Systems	Tustin Transform	Analysis	Multi-Rate Sampling	Data Holds	Alias Response	Root Locus
Digital Control Systems	Frequency Response	Inter-Sample Ripple	Servo Analy-																			
Sampled Data	Switch Decomposition	Computational Delays	sis																			
z-Transforms	Closed-Loop Systems	Flying Qualities	Closed-Loop																			
w-Domain	Linear Systems	Tustin Transform	Analysis																			
Multi-Rate Sampling	Data Holds	Alias Response	Root Locus																			
20. ABSTRACT (Continue on reverse side if necessary and identify by block number)																						
<p>Revisitation and extension of classical sampled data approaches for the analysis of discretely controlled continuous systems is the focus of this report. A review of basic linear analysis topics required to support later developments is given. These topics include Laplace, z- and advanced z-transform facts; partial fraction expansion; data holds and the switch decomposition technique. Extension of switch decomposition for the vector signal case is given.</p> <p style="text-align: right;">(continued)</p>																						

DD FORM 1473
1 JAN 73

EDITION OF 1 NOV 65 IS OBSOLETE

Unclassified

SECURITY CLASSIFICATION OF THIS PAGE (When Data Entered)

20. ABSTRACT (Continued)

The w' -domain is defined by a bilinear transformation of the z -domain. Properties of the w' -domain are developed. It is demonstrated that all analysis and synthesis techniques of the frequency and s -domains carry over directly for the w' -domain. This is with the one exception that the imaginary axis of the w' -plane is in terms of $(2/T) \tan (\omega T/2)$ rather than angular frequency, ω , as in the s -plane. (T is the sampling period.) Effects of sampling rate and data hold and algorithm-induced delays are readily assessed in the w' -domain.

A new direct transform domain approach for analyzing two-rate sampled systems is developed. This approach also applies for multi-rate sampled systems in restricted circumstances. Utility of this approach resides in its operator notation and conventions for manipulation in connection with vector block diagram algebra. This, in turn, expedites development of pulse transfer functions and of response recursion relations for multivariable, closed-loop systems. This is accomplished without resorting to the more complicated switch decomposition method.

Multi-rate sampling analysis procedures are used to sharpen the concept of "frequency response" for discretely excited, continuous systems. Frequency response, in this case, pertains to steady-state responses at the input frequency and its positive aliases. Simple expressions are developed for computing the amplitude ratios and phase angles as a function of these frequencies. Results are presented in terms of the familiar Bode plot. This Bode plot must be interpreted in a novel way, however. Similar expressions, appropriate for interpreting "frequency response" data obtained from sampled records of continuous responses, are also developed. These frequency response methods apply for analysis of both open-loop and closed-loop discretely controlled continuous system responses, and are useful for assessing intersample ripple effects.

All methods of analysis presented in this report are closed-form and exact in that no approximation is required in the mathematical development of any result.

Contrails

FOREWORD

The research described in this report was performed by Systems Technology, Inc., Hawthorne, California, under Air Force Contract F33615-77-C-3026. The AFFDL Task Number 03, Flight Control Research, was under Project Number 2307, Mechanics. This work was directed by the Control Criteria Branch, Flight Control Division, Air Force Flight Dynamics Laboratory, Air Force Systems Command, Wright-Patterson Air Force Base, Ohio. The work was administered by Frank L. George and Capt. Dennis G. J. Didaleusky.

Richard F. Whitbeck was the Systems Technology, Inc., Project Engineer under the direction of Duane McRuer. The Project Engineer was assisted by L. G. Hofmann.

The authors wish to express their appreciation to the Systems Technology publication staff for their efforts in preparing both this lengthy report and the notes for the short course (based on the material herein) given at WPAFB in June 1978.

The authors also wish to express their thanks to Mr. George for his appreciable efforts on this program. Captain Didaleusky's considerable facility with the technical concepts set forth in this report provided a significant impetus to the overall effort. In addition, he has authored Subsection V.K and Appendix G of Volume II.

This report covers work performed from March 1977 through June 1978. The report was submitted by the authors in October 1978.

Contrails

INTRODUCTION

Widening flight envelopes coupled with increasingly stringent operational demands on military aircraft have forced the use of more complex stability and control augmentation systems. This trend has created problems in interpreting the applicable military specification for the flying qualities of piloted aircraft, MIL-F-8785B(ASG). For example, the flight control system (FCS) may introduce additional dynamics which greatly alter the short-term response of the aircraft. The problem stems from the fact that, although the specification refers to "short period response in angle of attack," the requirement was based on configurations for which this response was defined by a natural short-period mode. The specification does not consider additional modes, which might be introduced by the FCS. Since the pilot senses the total response (sum of natural airframe modes plus FCS modes), specification of the short-period roots alone does not necessarily define the physical situation or insure acceptable flying qualities. Thus, if the specification is to be applied with any validity, parameters of an equivalent classical lower-order system must be found which will model the higher-order airplane dynamics and produce a good fit to the actual overall response.

AN ADDITIONAL CONCERN: PURPOSE OF THE STUDY

The criteria of MIL-F-8785 presume an analog augmentation system. There is now an additional concern for response characteristics which are unique to digital augmentation systems. It is the purpose of this study to identify those characteristics which are unique to the digitally controlled system, and to review the quantitative tools available which permit an assessment of the effects of these characteristics relative to the MIL-F-8785 requirements. The larger issue of what additional flying qualities criteria are required is outside the scope of this study.

DIGITAL EFFECTS

The results of this study indicate that two important characteristics are introduced by digital control laws. They are:

- The effective delay introduced by the A/D and D/A process, and also the delay introduced by the digital algorithms and computational frame time.
- The "control roughness" or inter-sample ripple introduced when the digital computer is coupled to the control actuators using data holds.

REASONS FOR CONCERN

The first characteristic is of great concern to the flying qualities community since even relative small delays are potentially important in certain closed-loop piloting tasks involving motion cues and/or pilot-induced oscillations.

The second characteristic is of concern since aircraft response resulting from control roughness is in effect an additional disturbance source.

EVALUATION TOOLS

Measures of the effective time delay introduced by the A/D computation, D/A conversion process can be computed using a variety of analytical techniques that apply at the sampling instants. For example, w' -, w -, or z -domain analyses and discrete frequency response techniques can be applied effectively to obtain both a quantitative and qualitative evaluation of the delay introduced.

The second characteristic is more difficult to assess since it involves the response of the continuous system during the

inter-sample interval. Therefore, analysis tools such as the "sampled spectrum" (sampled frequency response) are of little value.

REFINEMENT OF EVALUATION TOOLS

This leads to the other main objective of this study — to encourage the practicing engineer to gain working familiarity with three analytical tools well suited for the analysis of digitally controlled systems:

- 1) Analysis (and synthesis) in the w' -domain.
- 2) Multi-rate transform domain approach.
- 3) The continuous frequency response of a discretely excited system.

The first two tools are not new, having appeared in the literature at least fifteen years ago. However, the emphasis then was so different as to almost hide many of the properties that are most valuable in the analysis of multi-rate systems. The third tool is better described as "new," since the "old" tool on which it is based (the discrete frequency response) appears to have been very poorly understood and often improperly used.

w'-DOMAIN — BOTH AN ANALYSIS AND SYNTHESIS TOOL

The w'-domain is related to the well-known w-domain by a scalar transformation and to the z-domain by a bilinear algebraic transformation. We believe that those engineers skilled in frequency domain design procedures will immediately feel at home with analysis in the w'-domain, since all analog control system design technology transfers completely for digital control system design. In the w'-domain, the "analog" control system designer is transformed instantly into a "digital" designer.

A MULTI-RATE TRANSFORM DOMAIN APPROACH

The second item deals with a multi-rate transform domain approach that has been developed into an effective tool for analyzing the transient inter-sample response of discretely excited systems. That is, it yields recursion equations describing the inter-sample performance to any degree of fineness desired without increasing computer storage requirements.

CONTINUOUS FREQUENCY RESPONSE, A TOOL THAT CAN BE USED TO ASSESS BOTH DIGITAL EFFECTS (TIME DELAY AND RIPPLE)

It is tempting to describe this method of analysis as "frequency response" evaluation since it applies equally for continuously controlled systems as well as for multi-rate discretely controlled systems. However, this must be further qualified because of possible confusion with the concept of the "sampled spectrum." In computing the sampled spectrum one finds the lowest-frequency sine wave that fits the sampled response at the sampling instants. The sampled spectrum is commonly, but incorrectly, understood to be the frequency response of a discretely controlled system. For this reason it is preferable to describe the new method more precisely as the "continuous frequency response of a discretely excited system." Once a method is in hand for computing the spectral content of the continuous response, then one has the means for assessing both of the digital characteristics discussed above. The frequency response magnitude data can be used to quantify control roughness, while the phase data can be used to quantify the effective time delay.

SECTION I. INTRODUCTION

Discusses the artifacts introduced when a digital controller replaces an analog controller.

SECTION II. MATHEMATICAL PRELIMINARIES

The fundamentals of sampled-data control theory are reviewed to the extent necessary to "refamiliarize" the engineer with its terminology and background mathematics. No proofs are given; results are stated and illustrative examples are given to demonstrate viewpoints which will be needed at later points in order to develop an understanding of the three analytical tools mentioned above. This section also serves to introduce a multi-rate terminology.

SECTION III. DESIGN IN THE w' -DOMAIN

Section III is devoted to modest extensions of classical analysis and synthesis techniques for digitally controlled systems. Emphasis is upon analyses conducted in the w' -domain. The w' -domain offers the advantage that nonminimum-phase effects of the sampling and data-hold operations and of sampling rate can be accounted for directly without approximation while using conventional frequency domain design tools such as root locus and Bode plots. These conventional frequency domain design tools can be used to considerably greater advantage in the w' -domain than in the w - or z -domains because several more powerful analogies exist between the s -domain and the w' -domain. These analogies are, in a sense, the key to exploiting the w' -domain for design purposes, making direct design in the w' -domain an attractive alternative to design by emulation.

SECTION IV. MULTI-RATE TRANSFORMS

A basic transform domain approach, the "T/N method," which eliminates a variety of dimensional and indexing problems associated with state transition and switch decomposition methods, is developed in Section IV. The approach is very efficient for computing the response of discretely controlled continuous systems both at sampling instants and at equally spaced times during the inter-sample interval. The method also requires a minimum of information to define the system for the computer program.

SECTION V. CONTINUOUS FREQUENCY RESPONSE

The T/N method discussed in Section IV is used as a departure point in Section V to extend frequency response concepts to include the continuous frequency response of a discretely controlled system. The discrete frequency response concept has not been particularly productive for the analysis of discretely controlled systems, since it is limited to determining the amplitude and phase of the single sinusoid that fits the output samples of a single-rate system at the sampling instants. Development proceeds by first removing this restriction for open-loop systems and then extending the results to single-rate closed-loop systems. Finally, the solution for the multi-rate closed-loop case is developed using the results of Section IV.

SECTION VI. APPLICATION EXAMPLES

An application pertinent to the flying qualities/flight control system interface is taken up in Section VI.

SECTION VII. CONCLUSIONS AND RECOMMENDATIONS

Section VII contains the conclusions and recommendations.

OVERVIEW OF DESIGN IN THE w' -DOMAIN

BACKGROUND

A common design practice for digital flight control systems is to first develop a good analog design and then emulate it digitally. The dominant reasons for this approach are:

- Reliance on system design criteria developed for analog systems.
- Desire to preserve the large body of design experience built up using conventional design approaches.

The emulation design approach is diagrammed in the figure opposite. The primary signature of this technique is that the digitized version of the analog control law is evaluated on the basis of a "fidelity" criterion — that is, how closely does it approach the continuous design. This approach often leads to excessively high sample rates.

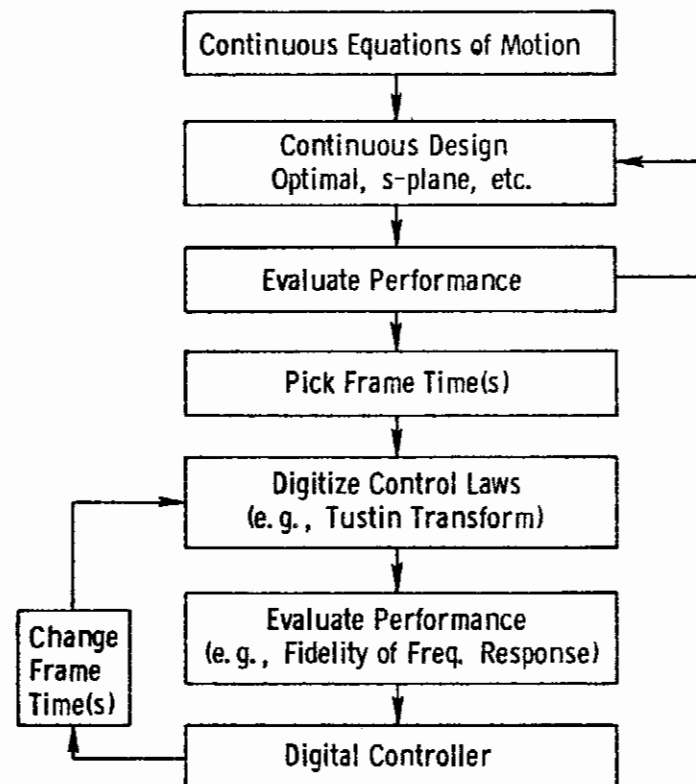

REVIEW OF THE DIRECT DIGITAL DESIGN PROCESS

The direct digital design process can be reviewed with the aid of the figure. The design procedure begins with the discretizing process wherein the (continuous) equations of motion are placed in a discrete format. This can be done using several approaches. For example, state transition or z-transform techniques may be used. The use of zero-order holds (ZOH's) to couple the output of the digital computer to the control actuators is usually implied.

After the equations of motion have been discretized, the direct digital design can be carried out using a wide variety of design aids and tools. For example, an "optimal" design might be attempted or one could carry through a w-domain approach, just to mention two possibilities. In particular, design in a modified w-plane, called the w'-domain, is a most effective tool that will be discussed in the next section.

Continuing on with the figure, it is seen that (whichever design tool is used) a candidate digital controller results whose performance must be evaluated. In this regard, care must be taken to evaluate the continuous system variables in response to the discrete control action (e.g., the "inter-sample" response must be evaluated).

It may well occur that the design specifications will not be satisfied on the first try, so that it becomes necessary to iterate in order to refine the design. Indeed, one may even find it necessary to select new frame times (sampling rates), in which event the discretized equations of motion will have to be recomputed. The figure presumes, however, that eventually the design technique is "successful" and the process stops with a definition of the digital controller.

The selection of the design procedure to be used will, of course, depend on the background and experience of the engineer(s)

who are charged with the responsibility for the control system design. Some will quite naturally prefer "modern" optimal approaches, while others will be better versed in the more classic frequency domain concepts. The skill of the designer and his familiarity with the design tools he has elected to use will determine the number of iterations that have to be carried through in the design cycle shown in the figure. In particular, the w'-domain approach is now emerging as a preferred technique for the direct synthesis of digital control laws. The reasons for this will be discussed in the next section.

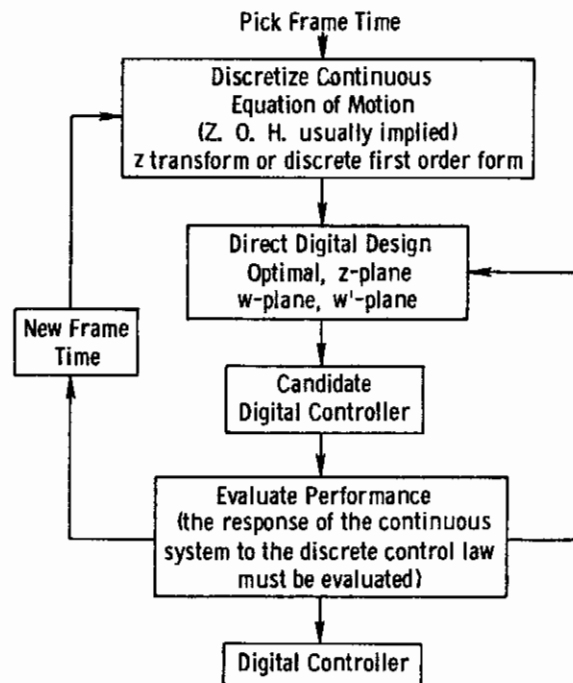

PROPERTIES OF w'

The definitions of the Tustin transform, the w-transformation, and the w'-transformation are given in the opposing equations.

Note the following:

- w' is scaled w.
- Equation for w' is identical in form to the Tustin transform.

The Tustin approach is a direct substitution for s, whereas w' requires a valid discretization of the continuous equations of motion.

w' is an effective domain for carrying out digital synthesis. The first reason for this is

$$w' \rightarrow s \quad \text{as} \quad T \rightarrow 0$$

For small values of T, the w'-domain has the attribute of approximating s. That is, at "low frequencies" it closely approximates the frequency domain. This is an attribute that the w-domain does not have.

Definitions

$$\text{Tustin: } s = \frac{2}{T} \frac{(z-1)}{(z+1)}$$

$$w: w = \frac{(z-1)}{(z+1)}$$

$$w': w' = \frac{2}{T} w = \frac{2}{T} \frac{(z-1)}{(z+1)}$$

where $z = e^{sT}$
(T is the sampling period)

$$w' = \frac{2}{T} \frac{(z-1)}{(z+1)} = \frac{2}{T} \frac{(e^{sT}-1)}{(e^{sT}+1)}$$

Apply L'Hôpital's rule once to obtain the limit as $T \rightarrow 0$

$$w' \left| \lim_{T \rightarrow 0} = \frac{2se^{sT}}{e^{sT} + Te^{sT} + 1} \right| \lim_{T \rightarrow 0} = s$$

$$w \left| \lim_{T \rightarrow 0} = \frac{e^{sT} - 1}{e^{sT} + 1} \right| \lim_{T \rightarrow 0} \equiv 0$$

Contrails

The second attribute of the w' -domain is:

- The nonminimum-phase effects of data holds become clearly evident.

This is demonstrated by considering the transfer functions which pertain in the various domains, for a second-order low-pass system. The equations assume the use of a zero-order hold for reconstructing the sampled input signal to the continuous system element.

Note the following, which are manifestations of more general results contained in Volume II.

- The z -domain transfer function bears almost no relationship to the s -domain transfer function. Even at the relatively low data rate corresponding to $T = 0.1$ sec, the z -domain poles are extremely close to the unit circle.
- The s -domain transfer function can be considered to be equal-order over equal-order if the zeros at infinity are included.
- The w' -domain transfer function is equal-order over equal-order. Zeros at infinity in the s -domain move to either $2/T$ or some other location, for example:
- The numerical values of gains and time constants in the w' -domain are very similar to their s -domain counterparts. (Although not demonstrated in this example, this observation holds only for modes having an s -domain modal frequency which is well below the folding frequency. The fact that this observation holds true only under the stated conditions does not limit validity of the w' -domain analysis techniques in any way when the stated conditions are not satisfied. That this is so is demonstrated in Volume II.)

Let $T = 0.1$

Therefore, $2/T = 20$

$$\text{If } H(s) = \frac{5}{s^2 + 2s + 5}$$

$$\text{then } H(z) = \frac{.023z + .022}{z^2 - 1.774z + .819}$$

$$\text{and } H(w') = \frac{5.03 \left(\frac{w'}{599} + 1 \right) \left(-\frac{w'}{20} + 1 \right)}{w'^2 + 2.02w' + 5.03}$$

$$5 \rightarrow 5.03 \left(\frac{w'}{599} + 1 \right) \left(-\frac{w'}{20} + 1 \right)$$

MULTILOOP ANALYSIS IN THE w'-DOMAIN

Another important property of w' can be investigated with the aid of the two figures shown. The top figure represents a simple continuous design problem, whereas the lower figure represents the equivalent implementation via a digital computer. In these figures x_1 and x_2 are the states of the system, δ_e represents the controller, and α_g represents a gust disturbance input. H_1 , H_2 , and H_3 are the compensation networks which are to be designed in such a manner that the closed-loop design objectives are achieved.

The set of equations given describes the matrix of closed-loop transfer functions which describe both systems. When dealing with the top figure, the argument is s ; when dealing with the lower figure the argument is w' . This matrix of closed-loop transfer functions is written with the aid of the multiloop analysis method. Although developed explicitly for the s -domain, the technique is equally applicable in the w' -domain, as are all the other s -domain design tools such as root locus, Bode plots, Nyquist diagrams, etc. These points are discussed more thoroughly in Volume II.

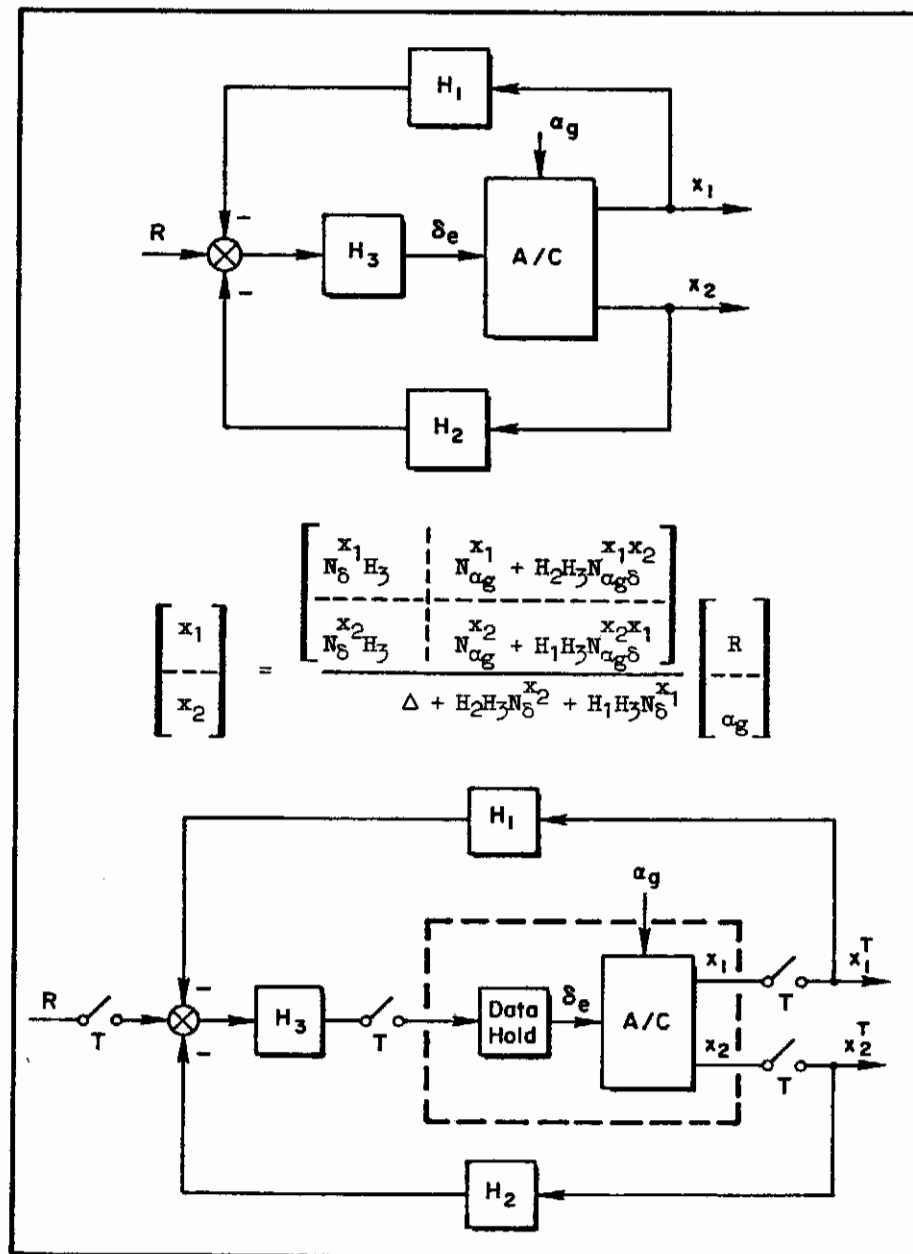

Contrails

The notation used in the closed-loop equations (either in z or w') involves numerators of the first and second kinds. In order to avoid a detailed discussion of the precise meaning of these terms, we will pick some particular numerical values and make the computations called for in the equation. The simplified numerical equations of motion are given by the top equations. The s , z , and w' implementations follows. From these equations we see:

- The closed-loop z -domain transfer function bears no numerical resemblance to the s -domain transfer function.
- The w' transfer functions do resemble the s -domain transfer functions.
- The w' -command input transfer functions pick up an additional nonminimum-phase zero at $2/T$ (20 rad/sec for this example).
- The w' disturbance input transfer functions pick up two additional nonminimum-phase zeros.

The last point is most important. It warns us that the introduction of a digital controller complicates matters pertaining to disturbance inputs to a far greater extent than it does for the command input paths.

Equations of Motion of Analog System

$$\begin{bmatrix} s+1 & 37 \\ -1 & s+3 \end{bmatrix} \begin{bmatrix} x_1 \\ x_2 \end{bmatrix} = \begin{bmatrix} -50 & -37 \\ 0 & -3 \end{bmatrix} \begin{bmatrix} \delta_e \\ \alpha_g \end{bmatrix}$$

s-Domain

$$\begin{bmatrix} x_1 \\ x_2 \end{bmatrix} = \frac{\begin{bmatrix} -3.75\left(\frac{s}{3} + 1\right)H_3 & -0.925s - 3.75H_2H_3 \\ -1.25H_3 & -1\left(\frac{s}{13.33} + 1\right) + 3.75H_1H_3 \end{bmatrix} \begin{bmatrix} R \\ \alpha_g \end{bmatrix}}{\begin{bmatrix} \frac{s^2}{40} + \frac{4}{40}s + 1 & \\ & -1.25H_2H_3 - 3.75\left(\frac{s}{3} + 1\right)H_1H_3 \end{bmatrix}}$$

z-Domain (T = 0.1)

$$\begin{bmatrix} x_1(z) \\ x_2(z) \end{bmatrix} = \frac{\begin{bmatrix} (-4.491z + 3.295)H_3 & (-2.851z + 2.851) + H_2H_3(-1.196) \\ (-.2127z - .1859)H_3 & (-.4013z + .0825) + H_1H_3(1.196) \end{bmatrix} \begin{bmatrix} R(z) \\ \alpha_g(z) \end{bmatrix}}{(z^2 - 1.352z + .6703) + H_2H_3(-.2127z - .1859) + H_1H_3(-4.491z + 3.295)}$$

w'-Domain (T = 0.1)

$$\begin{bmatrix} x_1 \\ x_2 \end{bmatrix} = \frac{\begin{bmatrix} -3.750000159\left(\frac{w'}{3.072} + 1\right)H_3\left(1 - \frac{w'}{20}\right) & -0.89404w'\left(1 - \frac{w'}{20}\right) - 3.75H_2H_3\left(1 - \frac{w'}{20}\right)^2 \\ -1.250000067\left(\frac{w'}{296.81} + 1\right)H_3\left(1 - \frac{w'}{20}\right) & -1.000000051\left(\frac{w'}{13.1823} + 1\right) + 3.75H_1H_3\left(1 - \frac{w'}{20}\right)^2 \end{bmatrix} \begin{bmatrix} R(w') \\ \alpha_g(w') \end{bmatrix}}{\left(\frac{w'^2}{42.2089} + \frac{4.3641}{42.2089}w' + 1\right) - 1.250000067\left(\frac{w'}{296.81} + 1\right)H_2H_3\left(1 - \frac{w'}{20}\right) - 3.750000159\left(\frac{w'}{3.0718} + 1\right)H_1H_3\left(1 - \frac{w'}{20}\right)}$$

w'-DOMAIN SUMMARY

To summarize, analogies between system formulations in the z- and w'-domains have been drawn. To arrive at the w'-domain formulation one must first discretize the problem by means of a valid mathematical technique if the effects of data holds are to be represented exactly. This leads to a statement of the discretized problem in the z-domain. The z-domain statement of the problem is then converted to a w'-domain statement by means of a bilinear algebraic transformation.

It is demonstrated in Volume II that direct digital control law synthesis in the w'-domain is a viable and practical alternative to design by emulation of a continuous system. Key properties of the w'-domain have been stated, and the "visibility" of data hold and sampling rate nonminimum-phase effects in the w'-domain have been demonstrated. More important is the fact that it has been pointed out that conventional frequency domain design procedures, such as multiloop analysis, Bode plots, root loci, etc., are valid and useful procedures in the w'-domain even in the presence of significant folding (s-domain modal frequencies greater than 1/2 sampling frequency). The impact of this is that in the w'-plane the controller designer can confidently synthesize digital controllers using considerably lower sampling rates than are required when an emulation design approach is used. Furthermore, the direct digital control law synthesis approach presented here requires no new analytical technique beyond those required by the emulation

design approach. The analytical techniques are merely applied and interpreted in the novel manner described in detail in Volume II.

COMMENTS ON THE UTILIZATION OF ENGINEERING EXPERTISE

"Analog" design procedures for the synthesis of flight control systems have been highly developed over the past two decades. It is for this reason that the "emulation" approach has been so widely used in the industry. By first designing the analog control law, the body of technology with respect to block diagram algebra, washout filters, limiters, etc., is preserved. This desirable situation is also true for direct digital design in the w'-domain.

The direct digital design method detailed in Volume II introduces a minimum of disruption into this process. Of course, the "analog" designer will no longer pass his design to a "digital" designer who specializes in the use of the Tustin transform for discretizing control laws. Rather, he will be supplied with data in terms of w'-domain transfer functions and therefore may proceed, using his analog tools, without regard to whether or not his data represent s-domain or w'-domain information. The main difference he perceives will be in terms of the nonminimum-phase zeros introduced by the particular sampling rate/data hold format being used. However, given his ability to cope with nonminimum-phase effects in the s-domain, it is apparent that he will be able to do the same in the w'-domain.

MULTI-RATE SYSTEMS AND COMPUTATIONAL DELAYS

The previous sections dealt with the synthesis of single-rate systems in the w' -domain; emphasis was on the fact that an "analog" system designer can use w' to literally transform himself instantly into a "digital" designer. In Volume II it is shown that the w' -domain design procedure can be applied for multi-rate sampled systems by using the "vector switch decomposition" concept. Further, since any viable digital theory must be capable of modeling computational delay, Volume II also includes a discussion of nonsynchronous sampling. The treatment of nonsynchronous sampling provides the basic theoretical structure for treating computational delays.

Vector switch decomposition will not be reviewed here since it is not a central feature of the three design tools being

discussed. However, we note that w' coupled with vector switch decomposition furnishes a powerful tool for the direct digital synthesis of multi-rate systems. It is a design tool capable of accounting for:

- 1) The finite time required for the computer to collect input data, compute the control algorithm and output to the controller.
- 2) The nonsynchronous data introduced by the use of a multiplexer/data bus for collecting input data.
- 3) Many different sampling rates.
- 4) Higher-order data holds, which can be used to smooth the outputs to the controllers.
- 5) Artifacts introduced by a distributed architecture.

MULTI-RATE TRANSFORM DOMAIN

A basic property of the transform domain algebra developed in Volume II is that a high sampling rate "operates through" a low one, provided that the ratio of the higher to the lower is an integer value (refer to the opposite equation for $C^{T/N}$). The superscript notation denotes the sampling rate involved. For example, $C^{T/N}$ indicates that the signal C is sampled at N/T samples/second.

For a given G and R, a recursion equation can be written in a manner that is similar to the single-rate case for which $N = M = 1$. To see this, consider a simple example, for which we define $z = e^{sT/N}$. If the running index of the recursion equation, n, is tied to the z^{-1} operator, the time domain recursion equation can be written directly using the fact that the input is set equal to $R(t)$ whenever n is an integer value of N/M , and set equal to zero whenever n is not an integer value of N/M .

These results are appreciably different in the presence of data holds. However, the results remain quite tractable and are detailed in Volume II for the zero-order hold as well as the slewer data hold. The slewer data hold is a coupler which produces a smooth ramp output over the inter-sample period and, in addition, provides a continuous output even at the sampling instants. Transfer functions for the zero-order and slewer data holds are contrasted in the opposite panel

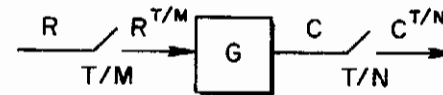

$$\text{If } C = GR^{T/M}$$

$$\begin{aligned} \text{Then } C^{T/N} &= [GR^{T/M}]^{T/N} \\ &= G^{T/N} R^{T/M} \end{aligned}$$

where N/M is an integer

$$G(s) = \frac{1}{s+1}$$

$$C^{T/N} = \frac{z}{z - e^{-T/N}}$$

Therefore,

$$C_n = e^{-T/N} C_{n-1} + \begin{cases} R_n & n/(N/M) = \text{Integer} \\ 0 & n/(N/M) \neq \text{Integer} \end{cases}$$

This agrees with the single-rate case when $N=M=1$

$$C_n = e^{-T} C_{n-1} + R_n$$

$$M_{\text{ZOH}} = \frac{1 - e^{-sT}}{s} = M_0$$

$$M_{\text{SLEW}} = \frac{(1 - e^{-sT})^2}{Ts^2} = \frac{M_0^2}{T}$$

The "T/N" approach is very useful in the analysis of closed-loop multi-rate systems since the transform domain equations can be written directly, without the need for computing an inverse. Using these equations, the time domain equations can be written in the same manner as in the single-rate case. An example is described in the opposite panel. Observe that two transform domain equations completely define the closed-loop fifth-order system (exclusive of data holds).

The T/N approach is developed in detail in Volume II. It serves as the basis for extending the concept of frequency response, from merely being the magnitude and phase of the sine wave that fits the sample points at the sampling instants, to the case of fitting N sine waves to the sample points and N-1 inter-sample points.

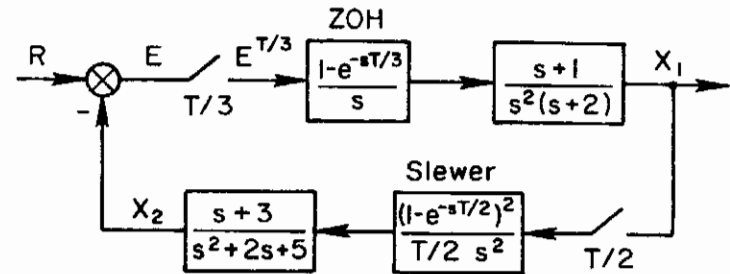

$$X_1^{T/N} = \left[\frac{(1 - e^{-sT/3})(s+1)}{s^3(s+2)} \right]^{T/N} (R^{T/3} - X_2^{T/3})$$

$$X_2^{T/N} = \left[\frac{(1 - e^{-sT/2})^2(s+3)}{(T/2)s^2(s^2+2s+5)} \right]^{T/N} X_1^{T/2}$$

Note:

N must be divisible by 2 and 3; it is otherwise arbitrary.

FREQUENCY RESPONSE OF A DISCRETELY EXCITED SYSTEM

THE OPEN-LOOP CASE

When a continuous (stable) linear system is excited by a sine wave, the steady-state waveform is comprised of a single wave at the same frequency as the input. It differs from the input wave only by a phase angle and a magnitude factor. Moreover, it is unnecessary to compute the actual transient response of the system when the behavior for large values of time is of interest, since both the magnitude factor and phase angle can be read from a Bode plot.

A similar but more complex situation pertains to a discretely excited system. Given that the system is stable, the continuous output waveform will contain much more than just a wave at the fundamental frequency; it will consist of the fundamental and all of its aliases. Thus, if the system is forced with $\sin bt$, the output will contain terms at b , $b + (2\pi/T)$, $b + (4\pi/T)$, The relative strengths and phase angles for these components will depend on the data hold employed as well as the system transfer function. Nevertheless, given a data hold and transfer function, the magnitude and phase angle of each and every component can be read from a particular "Bode plot." The situation which pertains in the open-loop case is summarized in the adjoining panel.

The finite N case is depicted in the adjoining panel. Here the objective is to find the magnitude and phase of the N sine wave which match the output waveform at the sampling instants and $N-1$ equally spaced inter-sample points. The equations which pertain are also summarized.

Note the following:

- The open-loop continuous frequency response case (above) requires only knowledge of the s -domain characteristics.
- The pulse transfer function, for a T/N sampling period, must be computed for the finite N case.

Detailed examples of both the finite and infinite N cases are given in Volume II.

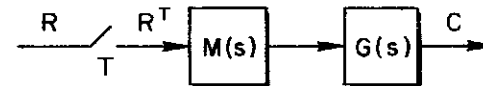

Let $R = \sin bt$

and $\omega_n = b + \frac{2\pi n}{T}$

for all n such that $n \geq (-bT/2\pi)$

$$C(t) \Big|_{t \rightarrow \infty} = \sum_{n=n_0}^{\infty} \left[A_n \sin \left(b + \frac{2\pi n}{T} \right) t + B_n \cos \left(b + \frac{2\pi n}{T} \right) t \right]$$

where

$$A_n + jB_n = \left. \frac{M(s)G(s)}{T} \right|_{s=j\omega_n}$$

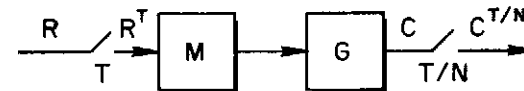

$$\left(C(t) \Big|_{t \rightarrow \infty} \right)^{T/N} = \left\{ \sum_{n=0}^{N-1} \left[A_n \sin \left(b + \frac{2\pi n}{T} \right) t + B_n \cos \left(b + \frac{2\pi n}{T} \right) t \right] \right\}^{T/N}$$

$$A_n + jB_n = \frac{1}{N} (GM)^{T/N} \Big|_{z=1 \pm j\omega_n(T/N)}, \quad z = e^{sT/N}$$

INTERPRETATION

Let $G(s) = 1/(s + 1)$ and $T = 1$ sec. Suppose that $R = 1 \sin t$ is the input, yielding the spectral components shown in the adjoining figure. The magnitude and phase angle (not shown) of the sine waves at $\omega = 1, 1 + (2\pi/T), 1 + (4\pi/T), \dots$, can be read from the Bode plot, with the assurance that the sum of the waves will be an exact match of the actual steady-state waveform.

The time response steady-state waveform is shown in the adjoining figure. "Traditional" Bode plot considerations would lead to the expectation of a relatively pure sinusoid, since the first "harmonic" component at $1 + (2\pi/T)$ is down in magnitude by something on the order of 30 dB. However, the transient response itself does not bear out this conjecture. The reason is that the higher-frequency terms are important; they are not "harmonic" terms but rather are modulation terms which must add to match conditions at the "T" switching boundaries. In this example, the input frequency does not bear an integer relationship to the sampling frequency, giving a "steady-state" waveform which is not periodic. Examples are given in Volume II which show that the steady-state waveform takes on the additional attribute of "periodicity" if the input sine wave bears an integer relationship to the sampling frequency.

It is most important to understand that the steady-state waveform shown would be exactly the same if $R = 1 \sin t$ or if

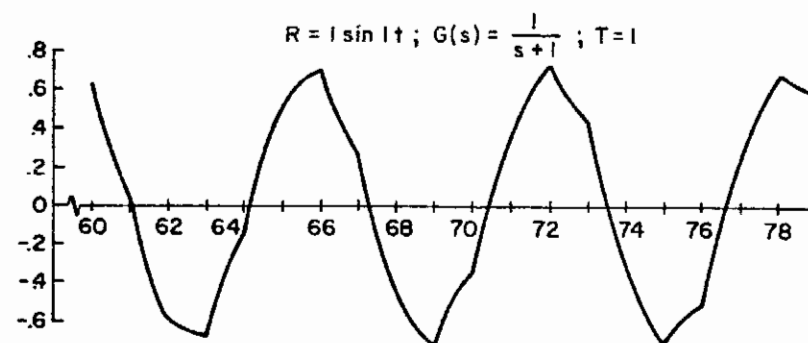
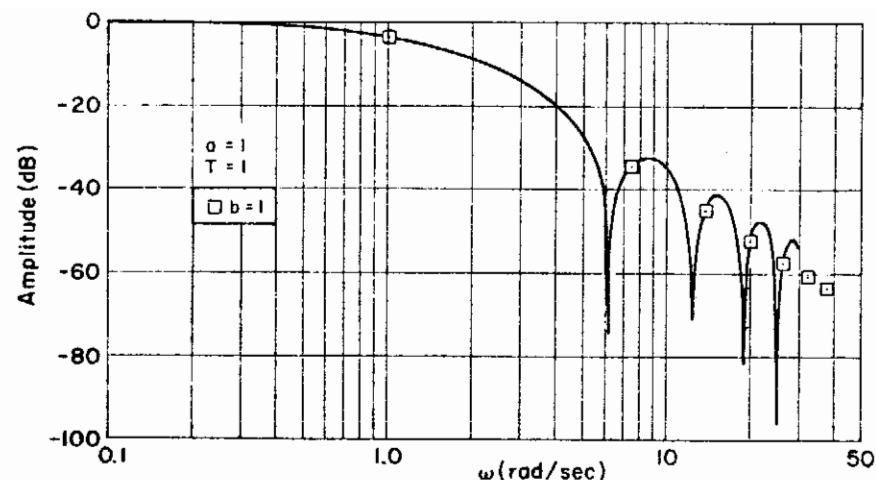

$R = 1 \sin [1 + (2\pi/T)]t$. That is, the sampler cannot tell the difference. Thus, the spectral components in the above figure would contain one sub-alias at $\omega = 1$ when R has an input frequency of $[1 + (2\pi/T)]$. In a like manner, if $b = 1 + (2\pi/T)$, the spectrum must contain sub-aliases at $\omega = 1, 1 + (2\pi/T), \dots, 1 + [2\pi(n-1)/T]$. This fundamental point is discussed in more detail in Volume II.

CLOSED-LOOP ANALYSIS

The closed-loop results will be configuration dependent. However, the mathematics are quite tractable and can be followed through on a case-by-base basis. What is more important is to have insight into the mathematical structure and the particular simplifications that surface in a closed-loop analysis. A particular closed-loop configuration will demonstrate the basic procedure .

The objective is to find the coefficients that describe the spectral components of the continuous output C. Since an equation can be written for $C^{T/N}$ in terms of E^T , the entire problem reduces to expressing E^T in terms of R^T . Then the open-loop results can be applied directly.

For finite N, the results are:

The limiting form as $N \rightarrow \infty$ is obtained directly by using the open-loop results.

The procedure demonstrated is a general one which is only mildly complicated in the multi-rate case. This point (together with a variety of illustrative examples) is elaborated on in Volume II.

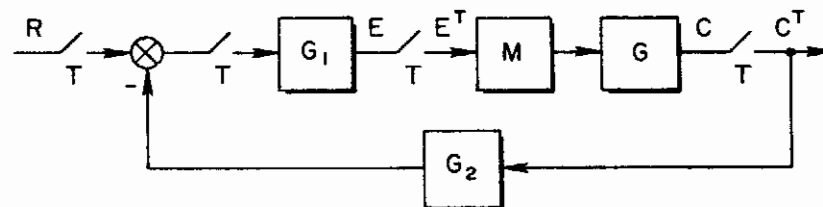

$$C = (GM)E^T$$

$$C^{T/N} = (GM)^{T/N} E^T$$

Via (vector) block diagram algebra

$$E^T = [I + G_1^T G_2^T (GM)^T]^{-1} G_1^T R^T$$

Let $G_A^T = [I + G_1^T G_2^T (GM)^T]^{-1} G_1^T$

so that $E^T = G_A^T R^T$

and $C^{T/N} = (GM)^{T/N} G_A^T R^T$

$$A_n + jB_n = \frac{1}{N} (GM)^{T/N} G_A^T \Big|_{z=1z\omega_n^T}$$

where

$$\omega_n = b + \frac{2\pi n}{T}, \quad n = 0, 1, \dots, N-1$$

$$A_n + jB_n = \frac{GM}{T} \Big|_{s=j\omega_n} G_A \Big|_{z=1z\omega_n^T}$$

AN ILLUSTRATIVE EXAMPLE

A simple example will be used to demonstrate the essential differences between the sampled spectrum and the continuous spectrum of a discretely excited system. Suppose the problem is to select the feedforward gain K_1 and the feedback gain K_2 so that a closed-loop pole at $z = e^{-.5T}$ is achieved. In addition, it is required that the steady-state response to a unit step input be unity.

These objectives are achieved with the gains shown in the table for two different values of the open-loop parameter a . In one case the open-loop system is "strongly" stable; in the other it is very unstable.

When the zero-order hold (M) is replaced by the slewer data hold, a lead filter is required in the forward path in order to satisfy the design objectives. Only the $a = 10$ case is shown for the slewer data hold.

The step input transient response shows that each design gives the same value at the sampling instant. Note the roughness in the zero hold responses and note the smoothness of the slewer design response.

The closed-loop frequency response (only the magnitude plot is shown) shows that the discrete frequency response spectrum ($N = 1$, all cases) cannot distinguish between the various combinations of open-loop plant and couplers (i.e., the zero-order hold or the slewer). On the other hand, the continuous frequency response spectrum (bottom three curves) distinguishes between the three designs.

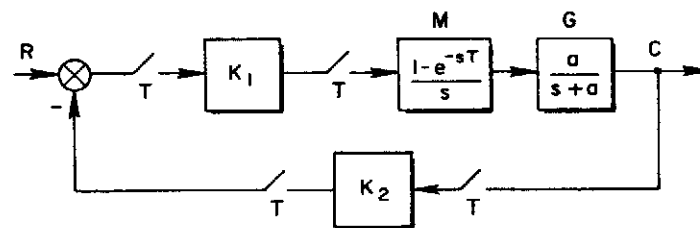

$T = 1.0$		
a	K_1	K_2
-4	-.00734	137.2
10	.393	-1.541

$a = 10$
Slewer

$K_1 = \frac{.437z}{z + .111}$

$K_2 = -1.541$

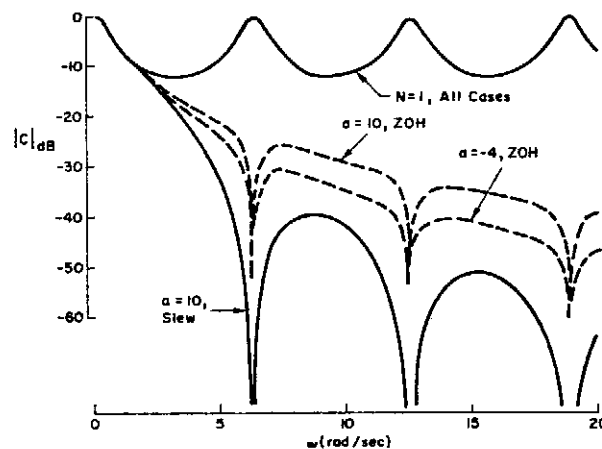
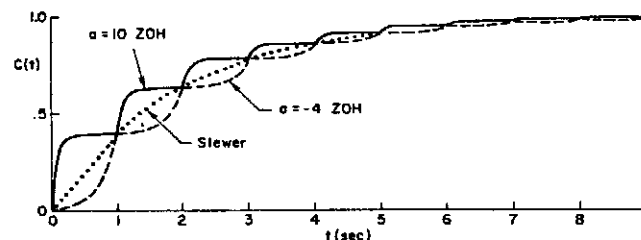

A FLYING QUALITIES APPLICATION

A continuous, closed-loop flying qualities example is reviewed. Then a digital implementation is considered in order to indicate the manner in which the continuous frequency response of a digitally controlled system concept can be used to modify the parameters of an equivalent model.

Current trends in fighter design frequently require some type of FCS to maintain the short-period frequency within acceptable limits at low speed. The airplane characteristics used in this example are typical of modern fighter aircraft in the power approach configuration. The attitude transfer function is given in the adjoining column. Since the phugoid frequency is only 1/5 as large as the short period, the two-degree-of-freedom constant-speed approximation is used for the example FCS shown.

Some type of compensation is desired because the low short-period frequency violates MIL-F-8785B and produces a sluggish pitch response. Feedback of lagged pitch rate results in an apparent increase in short-period frequency (and damping). This signal would be washed out to prevent the pitch damper from receiving low-frequency signals which might saturate the system.

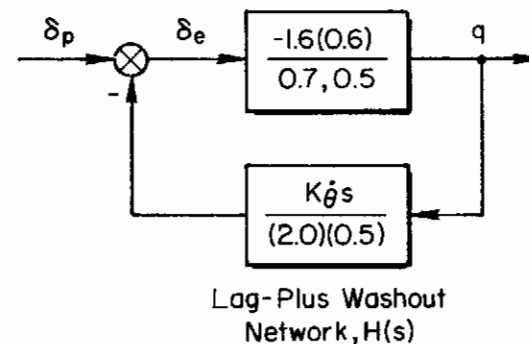

$$\frac{\theta}{\delta_e} = \frac{-1.6(0.1)(0.6)}{[0.05, 0.1][0.7, 0.5]} \doteq \frac{-1.6(0.6)}{s[0.7, 0.5]}$$

$$[\zeta, \omega] \Rightarrow s^2 + 2\zeta\omega s + \omega^2$$

$$(1/T) \Rightarrow s + 1/T$$

Contrails

Root locus techniques indicate that closing the loop at $K_{\theta} = -0.63$ results in short-period poles at 1.35 rad/sec.

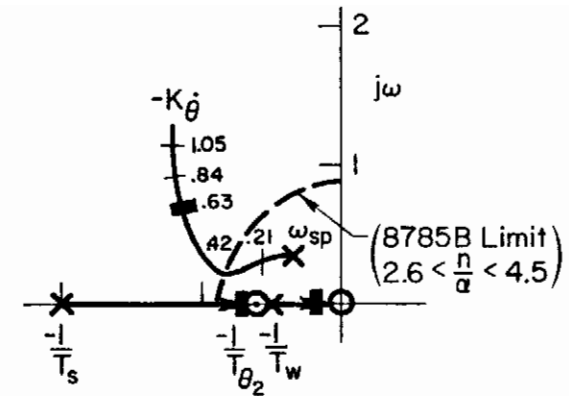

The augmented attitude dynamics are then given as:

$$\frac{\theta}{\delta_p} = \frac{-1.6(0.6)(0.5)(2.0)}{s(0.68)(0.2)[0.86, 1.35]}$$

It appears that the FCS increases the short-period undamped natural frequency and, apparently, specification compliance has been achieved. However, an equivalent lower-order system which gives approximately the same frequency response is shown as $(\theta/\delta_p)_{\text{eff}}$.

$$\left(\frac{\theta}{\delta_p}\right)_{\text{eff}} = \frac{-1.47(0.5)}{s[1, 0.5]}$$

This effective second-order system fitted to the actual system has a natural frequency of only 0.5 rad/sec and is critically damped. Plotting the apparent augmented ω_{sp} and the "effective ω_{sp} " on the MIL-F-8785B requirement illustrates the danger in considering only the short-period pole for specification compliance when a FCS is employed (see figure). Note that even though the FCS apparently increased ω_{sp} from 0.5 to 1.35 rad/sec, the effective response indicates that pitch rate feedback only increased damping. This vividly points out that an incomplete analysis can be misleading, i.e., specification of the short-period roots alone does not necessarily define the physical situation or insure acceptable flying qualities.

Comparing the augmented and effective short-period poles with the specification requirement indicates that:

- 1) The augmented short-period poles appear to meet Level 1, but
- 2) The "effective airplane" does not even meet Level 2,3 flying qualities.

Since the effective poles indicate the total response, this aircraft would very likely be rated poorly even though the actual short-period roots indicate specification compliance.

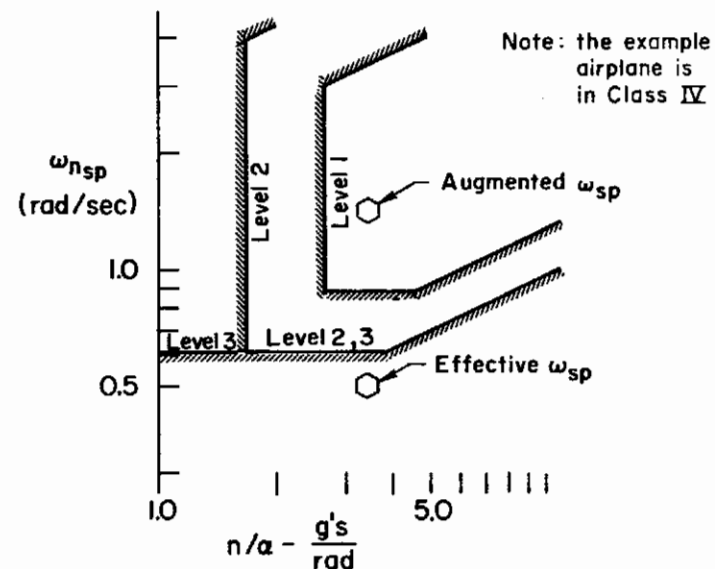

Comparison of Augmented and Effective Short-Period Roots
(Pitch Rate FCS)

The sluggish characteristics of the augmented airframe are indicated in the pitch rate time history to a step input of δ_p . Note that the time responses for the actual and effective transfer functions are in close agreement.

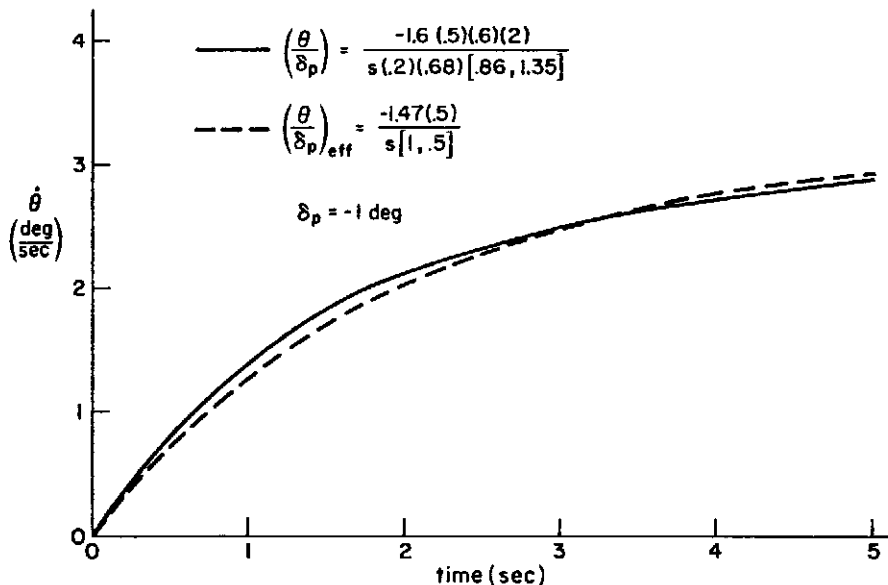

Comparison of Exact and Effective Time Responses

Next, a digital controller for the tactical fighter is considered. Here the Tustin transform (emulation) of the lag-plus-washout network, H, is used. Switch decomposition (e^{sT_0} , e^{-sT_0}) is used to model the nonsynchronous sampling that occurs due to a computational throughput delay of T_0 seconds. The associated timing diagram and switch decomposition procedures are covered in detail in Volume II.

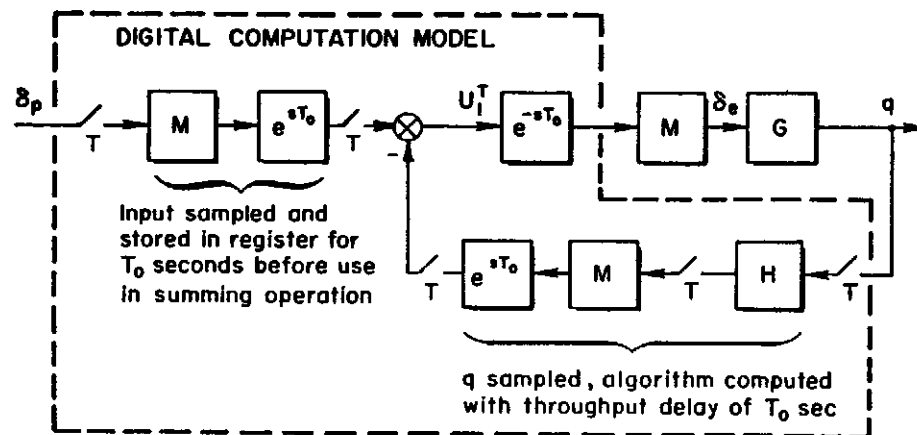

The closed-loop frequency response can be computed using the tools of Section IV, Volume II (only the first fold is shown). Notice at the relatively slow sample rate of 25 samples/sec that the difference between the magnitude plot for the "continuous" washout network and the discretized version only becomes significant at frequencies above 50 rad/sec. There is, however, a substantial difference between the phase angles of the continuous washout and the discretized version at frequencies above 2 rad/sec. This result is a typical one when the Tustin transform approach is used. The only recourse for decreasing the difference between the phase responses when the Tustin transform approach is used is to decrease the sampling period. This is the case because the Tustin transform does not account for the phase lag introduced by the A/D, D/A conversion process (i.e., the data holds).

The phase for the discretely controlled system is shown for three different values: $T_0 = 0$ ($\Delta = 1$), $T_0 = 0.3T$ ($\Delta = 0.7$), and $T_0 = T$ ($\Delta = 0$). Clearly, the closed-loop phase characteristic is sensitive to the through-put delay of T_0 seconds. The accuracy with which the lower-order system models the higher-order system would be improved by inclusion of a pure time delay term. However, specification of acceptable delay is not presently part of MIL-F-8785B. Therefore, further adjustments of the effective short-period damping and natural frequency in the lower-order model are required if the "digital" phase angle artifacts are to be accounted for in the format of MIL-F-8785B. The result will be an increase in the effective damping and a decrease in the effective short-period frequency. Either in this form or considering the lag shown in the figure, the result is further degradation of flying qualities due to the digital mechanization.

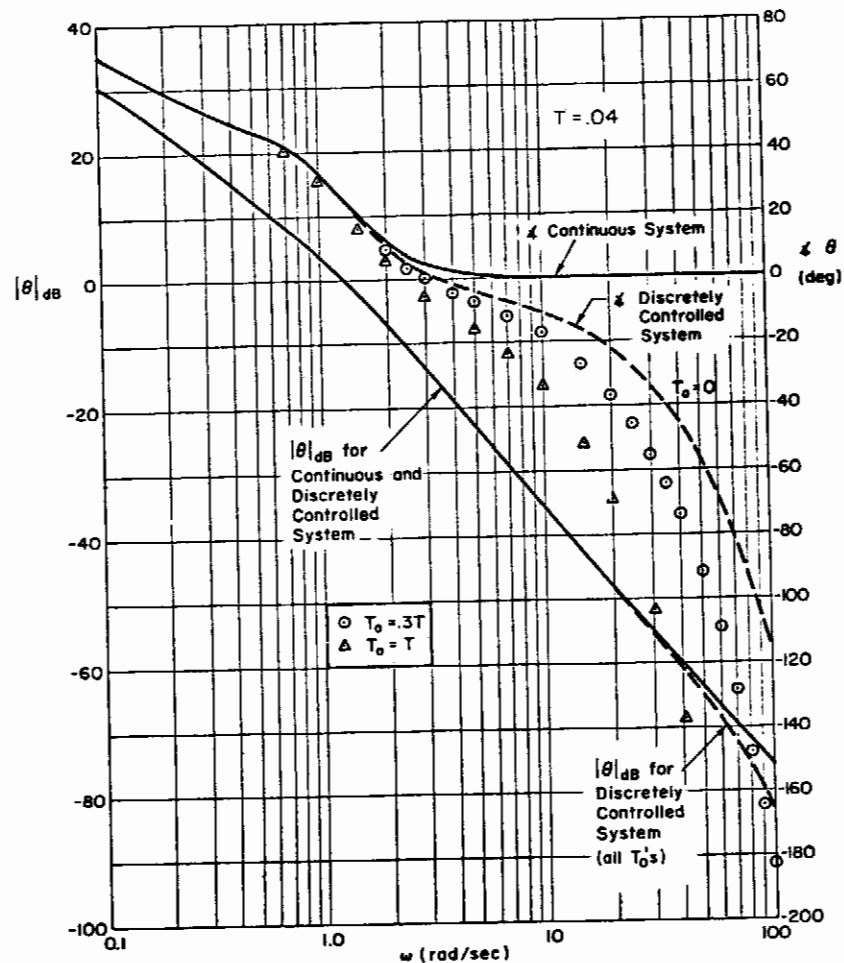

Fighter Attitude Dynamics (Digital Controller)

Contrails