

FDL TDR 64-112
Part I

FOREWORD

This report was prepared in-house under Project No. 1347, "Structural Testing of Flight Vehicles," Task No. 134703, "Structural Testing Criteria." The work was conducted by the Experimental Mechanics Branch, Structures Division, Air Force Flight Dynamics Laboratory, with Mr. W. R. Johnston acting as task engineer.

Contrails

ABSTRACT

This study was conducted to determine how accurately aerodynamic heating is simulated in the laboratory with radiant heat lamps under computer control. A study of aerodynamic heating theory resulted in the preparation of a digital computer program for calculating the parameters required as input data for the heat rate computer. The heat rate computer is used to control the heat input to an actual flight test specimen. Laboratory test results are compared with flight measured data to determine the degree of simulation. Test results indicate that aerodynamic heating may be adequately simulated up to 600°F. Laboratory simulation to higher temperatures are being studied for future programs.

This technical documentary report has been reviewed and is approved.



HOLLAND B. LOWNDES, JR.
Actg Chief, Structures Division
AF Flight Dynamics Laboratory

TABLE OF CONTENTS

SECTION	PAGE
INTRODUCTION	1
Aerodynamic Heating	1
THE HEAT BALANCE EQUATION	2
THE TEST PROGRAM	3
CONCLUSIONS	4
REFERENCES	10
APPENDIX I. IBM Digital Computer Program	11
APPENDIX II. Special Purpose Heat Rate Computer	19

SYMBOLS

<u>SYMBOL</u>	<u>DEFINITION</u>	<u>UNITS</u>
A	Area	Ft ²
B	Emissivity factor ($\epsilon\sigma$)	BTU/hr-ft ² -°R ⁴
B-h	B-h SCALE FACTOR potentiometer setting	---
c	Specific heat of the skin material	BTU/lb-°R
C _p	Specific heat of air	BTU/lb-°R
C _{pot}	C SCALE FACTOR potentiometer setting	---
C _{switch}	C SCALE FACTOR switch position	---
E	Voltage	Volts
Δe	Error signal	Volts
EI gain	Inherent gain associated with the EI RANGE switch position	---
G	Gain	---
G _{β}	Nocturnal irradiation	BTU/hr-ft ²
G _s	Solar irradiation	BTU/hr-ft ²
g	Acceleration due to gravity	Ft/sec ²
h	Convective heat transfer coefficient	BTU/hr-ft ² -°R
H _{aw}	Adiabatic wall enthalpy	BTU/lb
H _s	Skin enthalpy	BTU/lb
I	Current	Amperes
J	Conversion factor (778)	Ft-lb/BTU
K _D	Demand gain	---
K _{pot}	K SCALE FACTOR potentiometer setting	---

SYMBOLS (Continued)

<u>SYMBOL</u>	<u>DEFINITION</u>	<u>UNITS</u>
P.B. Offset	Proportional band offset	°R
q_e	Heat input from equipment	BTU/hr-ft ²
q_{loss}	Total heat losses due to internal convection, conduction, and radiation	BTU/hr-ft ²
r	Recovery factor	---
T_{aw}	Adiabatic wall temperature	°R
T_f	Local free stream temperature	°R
T_r	Effective temperature of space	°R
T_s	Skin temperature	°R
T_{stag}	Stagnation temperature	°R
T_{sp}	Programmed skin temperature	°R
T_{st}	Test skin temperature	°R
$T_{s \text{ range}}$	T_s RANGE switch position	°R
t	Time	Hr
V	Velocity	Ft/sec
w	Specific weight of the skin material	Lb/ft ³
Y	Conversion factor	BTU/hr-watt
α_β	Nocturnal absorbtivity	---
α_s	Solar absorbtivity	---
ϵ	Skin emissivity	---

SYMBOLS (Continued)

<u>SYMBOL</u>	<u>DEFINITION</u>	<u>UNITS</u>
η	Efficiency	---
σ	Stefan-Boltzmann constant (1.73×10^{-9})	BTU/hr-ft ² -°R ⁴
τ	Skin thickness	Ft

COMPUTER PROGRAM SYMBOLS

<u>SYMBOL</u>	<u>DEFINITION</u>	<u>UNITS</u>
H	Altitude	Feet
VA	Velocity of the vehicle	Ft/sec
THETA	Time	Sec
TS	Skin temperature	°R
DTS	Derivative of skin temperature with respect to time, $dT/d\theta$	°R/sec
XMN	Free stream Mach number	---
T2	Temperature of the air aft of the shock wave	°R
RN2	Reynolds number aft of the shock wave	---
TTS	Temperature values for table used to find skin emissivity and specific heat	°R
ES	Emissivity of the skin material	---
CPS	Specific heat of the skin material	BTU/lb-°R
DTSI	Derivative of skin temperature with respect to the time used in the Runge-Kutta calculations	°R/sec
ALFD	Angle of attack	Degrees
TAW	Adiabatic wall temperature	°R
HTC	Aerodynamic heat transfer coefficient	BTU/hr-ft ² -°R
Q	Total heat transferred	BTU/hr-ft ²
TAWP	Adiabatic wall temperature scaled for punching on tape for use on the heat rate computer	---
HP	Aerodynamic heat transfer coefficient scaled for punching on tape for use on the heat rate computer	---
TSP	Skin temperature scaled for punching on tape for use on the heat rate computer	---
K	Number of points	---

COMPUTER PROGRAM SYMBOLS (Continued)

<u>SYMBOL</u>	<u>DEFINITION</u>	<u>UNITS</u>
PRP	Prandtl Number raised to the $-2/3$ power	---
RNCR	Critical Reynolds number	---
D7	Wedge angle	Degrees
ELH	Distance from leading edge to the point in question	Feet
RHOS	Density of the skin material	Lbs/ft ³
DELTAS	Skin thickness	Feet
DELTAH	Time interval used in Runge-Kutta calculations	Sec
ESA	Average material emissivity	---
HGP	Altitude	Meters
A1, A2, A3	Constants for atmospheric calculations	---
TB	Atmospheric temperature constant	°R
PB	Atmospheric pressure constant	Lbs/ft ²
RHOB	Atmospheric density constant	Slugs/ft ³
HB	Altitude constant	Meters
P	Local atmospheric pressure	Lbs/ft ²
RHO	Local atmospheric density	Slugs/ft ³
TM	Local molecular-scale temperature of the atmosphere	°R
VS	Local speed of sound	Ft/sec
VIS	Local kinematic viscosity of the atmosphere	Ft ² /sec
T	Local temperature of the atmosphere	°R
A, B, C, D	Constants for finding the atmospheric temperature	---
ALFHD	Wedge angle plus angle of attack (D7+ALFD)	Degrees

COMPUTER PROGRAM SYMBOLS (Continued)

<u>SYMBOL</u>	<u>DEFINITION</u>	<u>UNITS</u>
P2	Pressure aft of the shock wave	Lbs/ft ²
RHO2	Density of the air aft of the shock wave	Slugs/ft ³
V2	Velocity aft of the shock wave	Ft/sec
ALFHR	(D7 + ALFD)/57.3	Radians
CP	Pressure coefficient	---
XMNN	Mach number normal to the shock wave	---
BETA	Shock wave angle	Radians
XMN2	Mach number aft of the shock wave	---
BMU2	Coefficient of viscosity aft of the shock wave	Lb/ft-sec
CH, YH, RH	Constants depending on Reynolds Number (RH is the recovery factor)	---
D1, D2, D3	Constants used in calculating enthalpies	---
H2	Enthalpy aft of the shock wave	BTU/lb
HAW	Adiabatic wall enthalpy	BTU/lb
HS	Skin enthalpy	BTU/lb
HR	Reference enthalpy	BTU/lb
D4, D5, D6	Constants used in calculating temperatures	---
TH	Temperature based on reference enthalpy	°R
BMUH	Coefficient of viscosity based on reference enthalpy	Lb/ft-sec
RHOH	Density based on reference enthalpy	Lb/ft ³
RNH	Reynolds Number based on reference enthalpy	---
SBC	Stefan-Boltzmann constant (4.758×10^{-13})	BTU/sec-ft ² - °R ⁴
TSA	Temperature used in Runge-Kutta calculations	°R

COMPUTER PROGRAM SYMBOLS (Continued)

<u>SYMBOL</u>	<u>DEFINITION</u>	<u>UNITS</u>
DTA, DTB, DTC	Derivative of temperature with respect to time used in Runge-Kutta calculations	$^{\circ}\text{R}/\text{sec}$
CPA	Specific heat of air	$\text{BTU}/\text{lb}-^{\circ}\text{R}$
BC	Average emissivity multiplied by the Stefan-Boltzmann constant	$\text{BTU}/\text{sec}-\text{ft}^2-^{\circ}\text{R}^4$
HMAX	Maximum aerodynamic heat transfer coefficient	$\text{BTU}/\text{hr}-\text{ft}^2-^{\circ}\text{R}$
TAWMAX	Maximum adiabatic wall temperature	$^{\circ}\text{R}$
BH	Calculated setting for the heat rate computer B-h potentiometer	---
DK	Demand gain obtained in scaling for the heat rate computer	---
TAWR	Adiabatic wall temperature range for the heat rate computer	$^{\circ}\text{R}$
TSMAX	Maximum skin temperature	$^{\circ}\text{R}$
TSR	Skin temperature range for the heat rate computer	$^{\circ}\text{R}$

Contrails

INTRODUCTION

This program was conducted to determine if elevated temperature test techniques used in the Structures Test Facility of the Air Force Flight Dynamics Laboratory provide an acceptable simulation of aerodynamic heating. A background study of aerodynamic heating theory was performed and a digital computer program was written to provide the necessary information for use on a heat control computer. Thermal simulation tests were conducted on a flight test article, and the laboratory test temperatures were compared with the flight test temperatures to determine the degree of simulation.

AERODYNAMIC HEATING

When a flight vehicle moves through the earth's atmosphere, the relative motion between the vehicle and the air creates a flow boundary layer (Reference 1). The frictional forces between the vehicle and the boundary layer convert the energy of the moving air into heat. The amount of heat transferred to the vehicle surface is dependent upon the difference between the boundary layer temperature and the skin temperature, and the coefficient of heat transfer. The rate of change of the skin temperature depends on the rate of heat exchange and the heat capacity of the skin structure. If steady-state aerodynamic conditions are maintained for a sufficient time, a condition will result wherein aerodynamic heat input equals the total heat losses, thus resulting in a constant surface temperature .

Some of the heat generated by the aerodynamic conditions is dissipated, or lost, from the vehicle's surface by radiation. At low velocities the skin temperatures are low and the resultant radiation losses are an insignificant portion of the total heat transferred. At large Mach numbers, and therefore high temperatures, the amount of heat radiated by the surface may be a large percentage of the heat transferred.

The aerodynamic heating properties are based on the local free stream conditions at the point of the vehicle under consideration. At velocities greater than the speed of sound, shock and expansion areas are produced that create local conditions different from the surrounding ambient atmospheric conditions. The changes that take place are dependent upon the shape of the vehicle. All of the calculations in this study are based on a wedge-shaped body. Although a large amount of the information in this report is applicable to any shape, many of the calculations in the digital computer program would require changing for use with any shape other than a wedge.

Manuscript released by author 7 July 1964 for publication as an RTD Technical Documentary Report.

THE HEAT BALANCE EQUATION

In order to investigate aerodynamic heating thoroughly, all possible heat inputs and losses must be recognized. For illustrative purposes, consider a flat plate insulated on all surfaces except the heated surface and subjected to an aerodynamic heating environment. The immediate environmental temperature will depend only on the vehicle altitude and velocity. The stagnation temperature is expressed by the following equation:

$$T_{stag} = T_f + \frac{V^2}{2g JC_p}$$

The temperature of the air stream next to the surface (the adiabatic wall temperature) is related to the ambient temperature and the stagnation temperature by the following expression:

$$T_{aw} = T_f + \frac{r V^2}{2g JC_p}$$

The amount of heat that reaches the surface of the vehicle is dependent upon the value of the convective heat transfer coefficient. This heat is represented by the expression $h(T_{aw} - T_s)$. Additional heat may be obtained by irradiation from surrounding bodies such as the earth and the sun. If the vehicle is radiating to space, the surface will lose heat according to the term $\epsilon\sigma T_s^4$. The heat capacity of the plate per unit time can be expressed as $cw\tau \frac{dT_s}{dt}$. The previous terms can be combined to form the following the

balance equation:

$$cw\tau \frac{dT_s}{dt} = h(T_{aw} - T_s) + \alpha_\beta G_\beta + \alpha_s G_s - \epsilon\sigma T_s^4$$

It must be emphasized that this expression represents the idealized case of a uniformly heated insulated plate with a unit area, constant thickness, and uniform material properties.

Since the idealized case seldom exists in actual flight, the basic heat balance equation must be modified to include other sources of heat inputs and losses. Additional heat inputs may be obtained from engines, electronic devices, electric motors, and other heat generating equipment. Heat may be lost by conduction to adjacent structure, internal convection and radiation, and through active cooling equipment. The heat balance equation can now be written as follows:

$$cw\tau \frac{dT_s}{dt} = h(T_{aw} - T_s) + \alpha_\beta G_\beta + \alpha_s G_s + q_e - \epsilon\sigma T_s^4 - q_{loss}$$

where q_e represents additional heat inputs, and q_{loss} represents additional heat losses.

During accelerated or decelerated atmospheric flight some of the terms become relatively insignificant. For instance, solar and nocturnal irradiation is significant only in space operations. Similarly, the heat generated by equipment is often a very small percentage of the heat generated by aerodynamic heating. By eliminating these insignificant factors the heat balance equation may be expressed as follows:

$$c_w \tau \frac{dT_s}{dt} = h (T_{aw} - T_s) - \epsilon \sigma T_s^4 - q_{loss}$$

This equation is the basis for the closed loop, computer controlled aerodynamic heating simulation tests.

THE TEST PROGRAM

When conducting elevated temperature tests, the philosophy is to simulate the external thermal environment and allow the structure to distribute the heat as it would in actual flight. This method is in contrast to the philosophy of adjusting the external test environment until some predicted internal temperature distribution is obtained. In addition, the specimen is used as a calorimeter, and the surface temperature is fed back from each control area to the computer which calculates any power change required. This instrumentation and control feature contrasts to the method in which heat flux gages were used by some French and British investigators.

It is obvious that radiant heating is different from convective heating and does not duplicate the mass flow encountered by a vehicle moving through the earth's atmosphere. The objectives of this program were to determine the validity of the laboratory's test philosophy and the accuracy of aerodynamic heating simulation using radiant heat lamps under computer control. If the temperature distribution obtained with radiant heating is the same as that obtained during flight, then it may be assumed that the aerodynamic thermal environment has been adequately simulated. In this study the laboratory test temperatures were compared with flight measured temperatures to determine the accuracy of laboratory simulation.

This study is also concerned with the adequacy of the design equations for the General Electric Heat Rate Computer, which is used for control of most elevated temperature tests conducted in this laboratory. Of particular interest is the computer limitation that constants be used for temperature dependent variables. For instance, the specimen emissivity and specific heat are known to vary with temperature, but a constant value must be used in setting up the computer (Reference 2). Similarly, the efficiency of a test setup will vary as the temperature and temperature rise rate change, but again the computer requires that the efficiency be considered a constant. In addition, since the computer's design equations were based on an idealized insulated plate, information was desired on what effect adjacent heat sources, heat sinks, and various structural members would have on the computer's control characteristics. The effects these factors have on thermal simulation tests are important for determining design requirements for future heat control computers.

Two test specimens, with complete flight data, were available. A nose cone specimen (a polished stainless steel truncated cone shell) was fabricated to be a duplicate of a Viking 10 rocket nose cone. Information for nose cone construction and test correlation was obtained from NRL Report 4531. "Flight Measurements of Aerodynamic Heating and Boundary-Layer Transition on the Viking 10 Nose Cone" (Reference 3). Care was taken in the laboratory setup, shown in Figures 1 and 2, to duplicate the flight conditions as closely as possible. Twenty-five thermocouples were installed on the specimen, nineteen internal data thermocouples and six external control thermocouples. The nose cone was divided into three thermal control areas, with maximum temperatures of approximately 300°F. Because of low temperatures and resultant low power requirements, the nose cone was abandoned in favor of the X-7A wedge-shaped wing.

The X-7A wing, shown in Figure 3, was originally designed to investigate the effects of transient aerodynamic heating on aircraft structures. The leading edge was ground to produce a knife-edge wedge with an included angle of nine degrees, insulative materials were applied to some areas, boundary layer trips were installed to produce turbulent flow, and some areas were etched to provide varying degrees of surface roughness. In addition to the skin thermocouples, thermocouples were installed on structural members to determine the internal temperature distribution. Construction details and flight test data are available in Reference 4.

The X-7A wing test setup is shown in Figure 4. The wing was placed between two polished aluminum reflectors, on which were installed 480 T-3 heating lamps (1000-watt). The wing was divided into eight thermal control areas, four for the top surface and four for the lower surface. The maximum skin temperature required was approximately 600°F. Temperatures were measured using the actual flight test thermocouples which consisted of 41 skin and 6 structural thermocouples installed inside the wing. Eight additional thermocouples were installed on the wing external surfaces for computer control purposes. The temperature was recorded, reduced and displayed "on-line" by means of ETSTF HSDAPS (Elevated Temperature Structural Test Facility's High Speed Data Acquisition and Processing System).

CONCLUSIONS

Satisfactory results were obtained in all tests controlled by the General Electric Heat Rate Computer. Laboratory temperatures were within 5 percent of the flight recorded temperatures. This is an acceptable accuracy when it is considered that the information originated with only the flight profile data, the calculations were performed by a digital computer, and the final test was controlled by a closed-loop computer.

The program test results have shown that aerodynamic heating can be accurately simulated up to 600°F with radiant heat lamps under computer control. However, some of the areas of original interest still require more study. For example, the temperatures reached to date are too low to reveal any significant information concerning the effect of using constants in place of temperature dependent variables. Also, in the X-7A wing test, no attempt was made to cool the wing to the sub-zero temperatures experienced at the beginning of the test flight. More accurate results would probably have been obtained if the wing had been initially cooled.

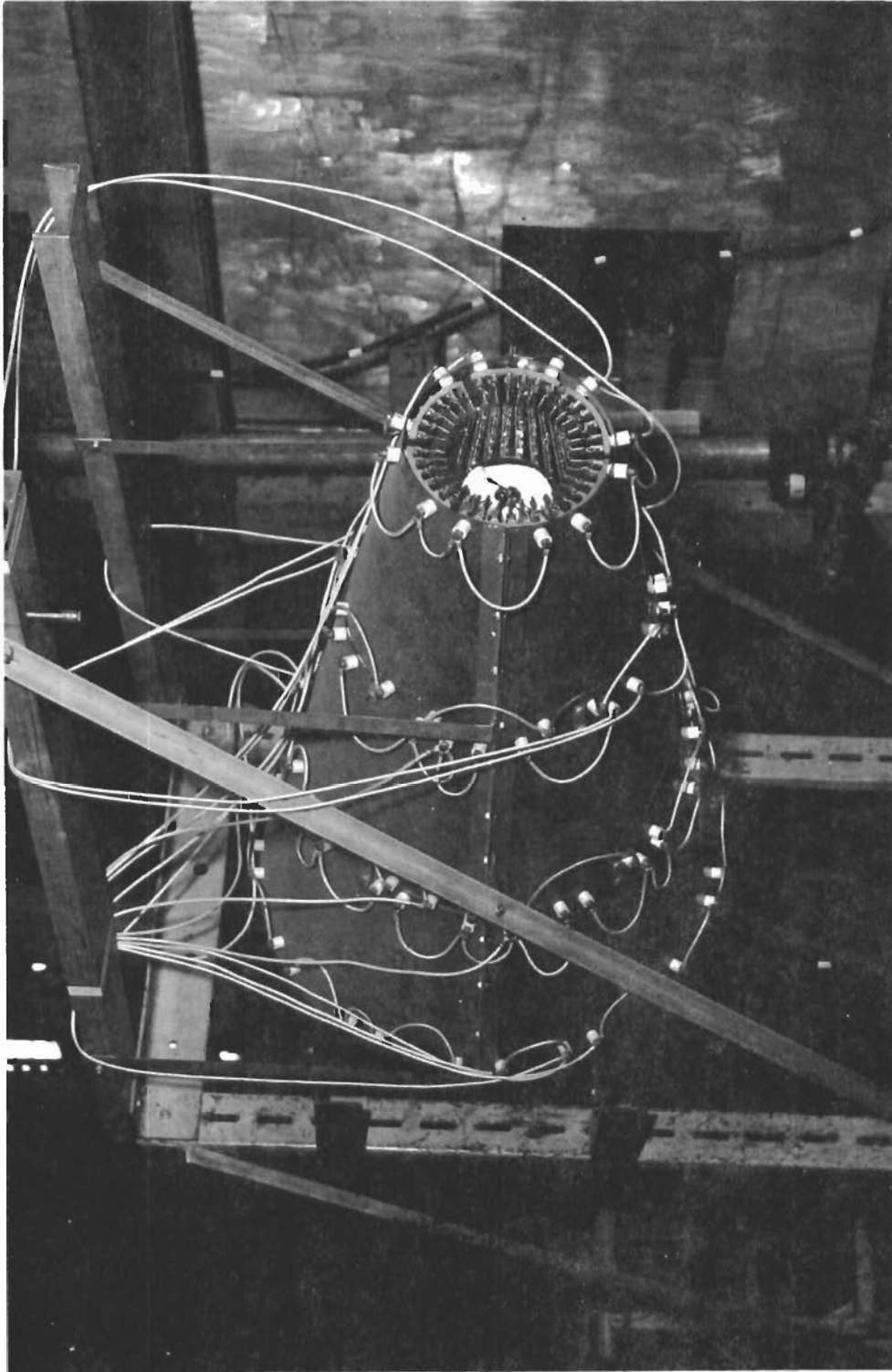

Figure 1. Front View of Nose Cone Test Setup



Figure 2. Rear View of Nose Cone Test Setup

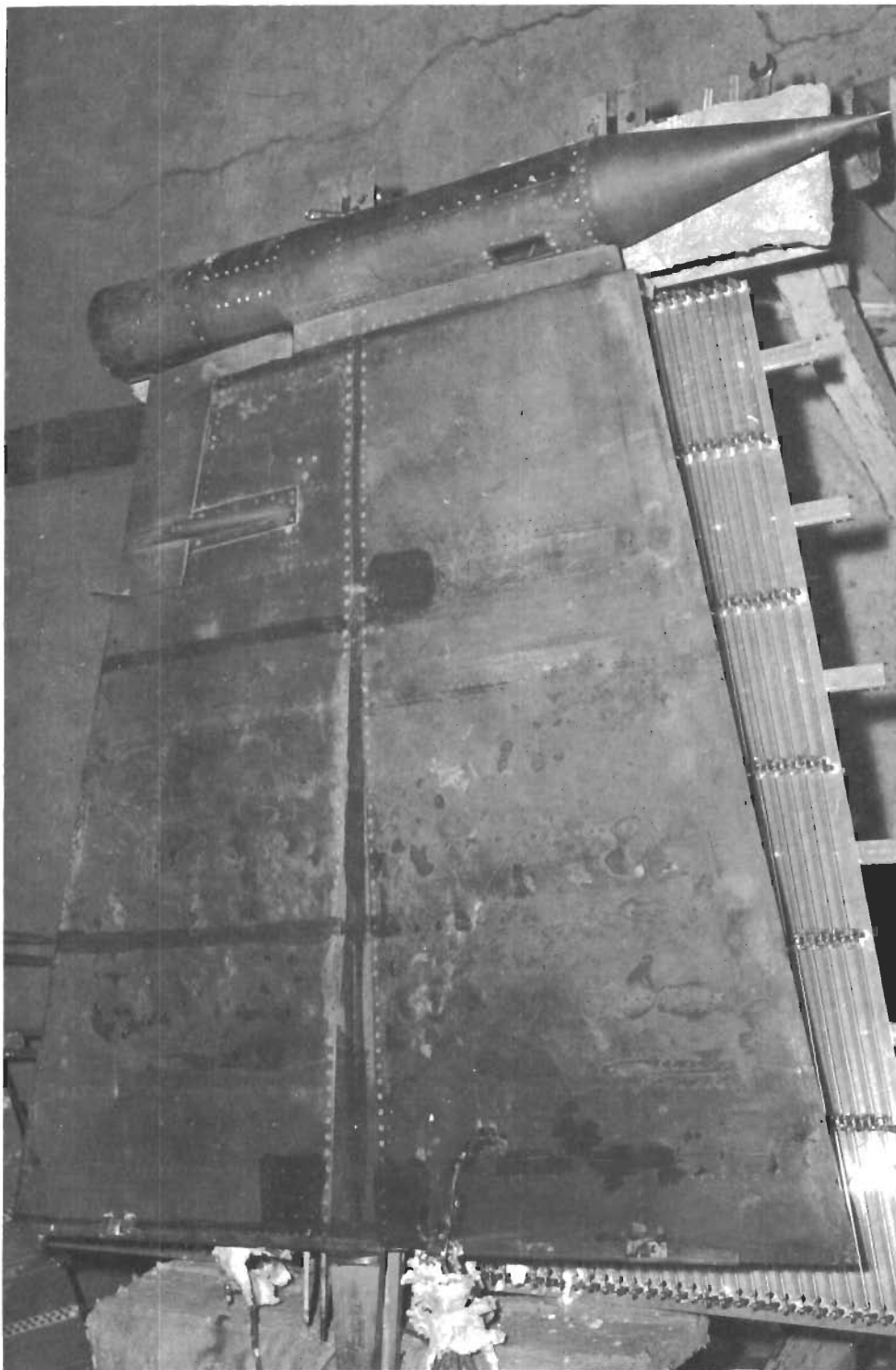

Figure 3. X-7A Wedge-Shaped Wing

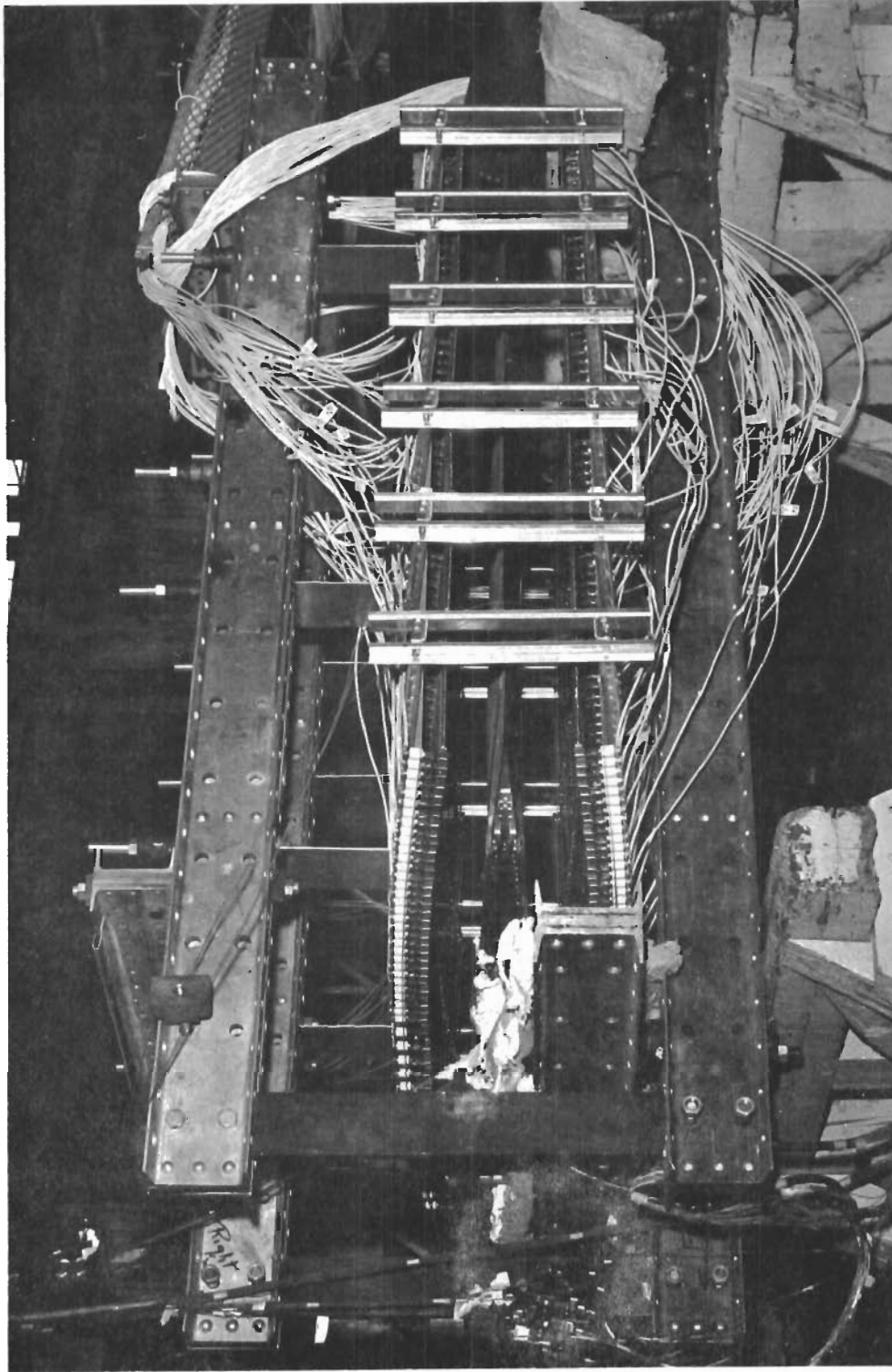

Figure 4. X-7A Wing Test Setup

Future programs are planned to study simulation techniques to higher temperatures where radiation losses and temperature dependent variables become more significant. The test programs will be controlled by a more versatile heat control computer and use a more elaborate test setup to duplicate the total flight environment as much as possible. It is anticipated that the information obtained will enable this laboratory to confidently and accurately simulate aerodynamic heating on any aerospace vehicle.

REFERENCES

1. Clark E. Beck. Handbook for Test Engineers (Radiant Heating). Aeronautical Systems Division Technical Memorandum, February 1963.
2. General Electric Heat Rate Computer for Wright Air Development Center. Instruction Manual, August 1959.
3. R. B. Snodgrass. Rocket Research Report No. XX, Flight Measurements of Aerodynamic Heating and Boundary-Layer Transition on the Viking 10 Nose Cone. Naval Research Laboratory Report 4531. June 16, 1955.
4. F. W. Buehl, L. C. Laaksonen, J. M. Lefferde. (UNCLASSIFIED TITLE) X-7 Thermal Data Program Final Report. WADD Technical Report 60-567. September 1960. (CONFIDENTIAL REPORT)
5. Robert C. Brown, Robert V. Brulle, Gerald D. Giffin. Six-Degree-of-Freedom Flight-Path Study Generalized Computer Program. Part I, Problem Formulation. WADD Technical Report 60-781. May 1961. pp. 89-91, 129-141.

APPENDIX I

IBM DIGITAL COMPUTER PROGRAM

More efficient performance of the many calculations required in this study were achieved by the digital computer program written for use on the IBM 7094 computer. The program is in the engineers computer language, FORTRAN, and is based on the aerodynamic heating subprogram given in Reference 5. The program shown as Table 1, has been designed to provide information peculiar to the operation of the General Electric Heat Rate Computer used in this laboratory, but it still retains its FORTRAN style and may be easily utilized by anyone with a knowledge of FORTRAN programming.

The calculations are based on the aerodynamic heating theory for a thin-skinned wedge at an angle of attack. By ignoring conduction into the structure, the heat energy stored in the skin is considered as the difference between the aerodynamic heat input and the heat radiated to space. From this theory the following differential equation is derived:

$$\frac{dT_s}{dt} = \frac{h}{c_w \tau C_p} (H_{ow} - H_s) - \frac{\epsilon \sigma}{c_w \tau} (T_s^4 - T_r^4)$$

where c and ϵ are properties of the skin material and surface condition, and h , C_p , and H_s are properties of the air flowing over the point under consideration. All of these items are functions of the skin temperature. Since the resulting differential equation has non-linear coefficients, the Runge-Kutta numerical method is used to obtain the solution. The calculations for determining the heat transfer properties are based upon a reference enthalpy method, and calculations for determining atmospheric conditions and local flow conditions are based upon the 1959 ARDC Model Atmosphere.

As it is written the digital computer program incorporates the following features:

1. Up to 300 time points for each location on the wedge
2. Altitudes up to 700,000 meters
3. Atmospheric properties calculated according to the 1959 ARDC Model Atmosphere
4. Provisions for the reading of multiple sets of data with easy variation of Prandtl Number, critical Reynolds Number, material, and location of each point in question
5. Provisions for a linear interpolation table for variation of material specific heat and emissivity with skin temperature
6. Runge-Kutta method of solving the non-linear differential equation

TABLE 1

IBM DIGITAL COMPUTER PROGRAM

```

C   SKIN TEMPERATURE PROGRAM
    DIMENSION H(300),VA(300),THETA(300),TS(301),DTS(300),XMN(300),T2(3
100),RN2(300),TTS(20),ES(20),CPS(20),DTSI(4),ALFD(300),TAW(300),HTC
2(300),Q(300),TAWP(300),HP(300),TSP(300)
4  READINPUTTAPE2,1,K
1  FORMAT (I3)
-  READ INPUT TAPE 2,2,(THETA(M),M=1,K)
  READ INPUT TAPE 2,2,(H(M),M=1,K)
  READ INPUT TAPE 2,2,(VA(M),M=1,K)
  READ INPUT TAPE 2,2,(ALFD(M),M=1,K)
  READ INPUT TAPE 2,2,(TTS(M),M=1,20)
  READ INPUT TAPE 2,2,(CPS(M),M=1,20)
  READ INPUT TAPE 2,2,(ES(M),M=1,20)
2  FORMAT (5E13,4)
5  READINPUTTAPE2,3,TS(1),PRP,RNCR,D7,ELH,RHOS,DELTAH,ESA
3  FORMAT (E11,4)
  DO 200 N=1,K
  HGP = .3048*H(N)/(1.+.3048*H(N)/6356766.)
  IF (HGP-700000.) 10,20,213
10 IF (HGP-200000.) 11,30,20
11 IF (HGP-170000.) 12,40,30
12 IF (HGP-160000.) 13,50,40
13 IF (HGP-105000.) 14,60,50
14 IF (HGP-90000.) 15,70,60
15 IF (HGP-79000.) 16,80,70
16 IF (HGP-53000.) 17,90,80
17 IF (HGP-47000.) 18,100,90
18 IF (HGP-25000.) 19,110,100
19 IF (HGP-11000.) 120,120,110
20 A1 = .222129E-05
  A2 = 9.76137
  TB = 2836.188
  PB = 2.9759E-06
  RHOB = 6.113E-13
  HB = 200000.
  GO TO 130
30 A1 = .350715E-05
  A2 = 6.83296
  TB = 2566.188
  PB = 5.8954E-06
  RHOB = 1.338E-12
  HB = 170000.
  GO TO 130
40 A1 = .754341E-05
  A2 = 3.41648
  TB = 2386.188
  PB = 7.5578E-06
  RHOB = 1.845E-12
  HB = 160000.
  GO TO 130
50 A1 = .886289E-04
  A2 = 1.70824
  TB = 406.188
  PB = 1.5562E-04
  RHOB = 2.232E-10
  HB = 105000.
  GO TO 130

```

TABLE 1 (CONT'D)

```

60 A1 = .241458F-04
   A2 = 8.5412
   TB = 298.188
   PB = 2.1809F-03
   RHOB = 4.261E-09
   HB = 90000.
   GO TO 130
70 A1 = 0.
   A3 = .206234E-03
   TB = 298.188
   PB = 2.108E-02
   RHOB = 4.1189F-08
   HB = 79000.
   GO TO 125
80 A1 = -.159202F-04
   A2 = -7.59218
   TB = 508.788
   PB = 1.2181
   RHOB = 1.39469E-06
   HB = 53000.
   GO TO 130
90 A1 = 0.
   A3 = .120869E-03
   TB = 508.788
   PB = 2.5155
   RHOB = 2.8804F-06
   HB = 47000.
   GO TO 125
100 A1 = .138466E-04
    A2 = 11.3883
    TB = 389.988
    PB = 51.979
    RHOB = 7.765E-05
    HB = 25000.
    GO TO 130
110 A1 = 0.
    A3 = .157689E-03
    TB = 389.988
    PB = 472.73
    RHOB = 7.062E-04
    HB = 11000.
    GO TO 125
120 A1 = -.225569F-04
    A2 = -5.25612
    TB = 518.688
    PB = 2116.21695
    RHOB = 2.37692E-03
    HB = 0.
    GO TO 130
125 P=PB*EXPF(-1.*A3*(HGP-HB))
    RHO = RHOB*EXPF(-1.*A3*(HGP-HB))
    GO TO 131
130 P = PB*EXPF(-1.*A2*LOGF(1.+A1*(HGP-HB)))
    RHO = RHOB*EXPF((-1.*(1.+A2.))*LOGF(1.+A1*(HGP-HB)))
131 TM = TB*(1.+A1*(HGP-HB))
    VS = 49.020576*SQRTF(TM)
    IF (HGP-90000.) 134,134,132
132 VS = 0.
    VIS = 0.
    IF (HGP-180000.) 135,135,133

```

TABLE 1 (CONT'D)

```

133 IF (HGP-120000.) 136,213,213
134 T = TM
    VIS = (T*SQRTF(T)*.0226988E-061/L(T+198.72)*RHO)
    GO TO 140
135 A = .759511
    B = .174164
    C = 220.
    D = 25.
    GO TO 137
136 A = .935787
    B = .273966
    C = 180.
    D = 140.
137 T = TM*(A-B*ATANF((HGP-C)/D))
140 IF (VS) 141,141,142
141 XMN(N)=0.
    GO TO 143
142 XMN(N)=VA(N)/VS
    ALFHD=D7+ALFD(N)
    IF (ALFHD) 143,143,144
143 P2=P
    RHO2=RHO
    T2(N) = T
    V2 = VA(N)
    GO TO 147
144 ALFHR = ALFHD/57.295
    CP=2.*ALFHR**2*(.6+SQRTF(.36+1./((XMN(N)*ALFHR)**2)))
    P2=P*(.7*CP*XMN(N)**2+1.)
    RHO2=RHO*(6.*P2/P+1.)/(6.+P2/P)
    T2(N)=T*P2*RHO/(P*RHO2)
    XMNN=SQRTF((6.*P2)/(7.*P)+1./7.)
    IF (XMNN/XMN(N)-1.) 146,146,143
146 BETA=ASIN(XMNN/XMN(N))
    XMN2=(1./SINF(BETA-ALFHR))*SQRTF(5./((6.*RHO2/RHO-1.)))
    V2=49.1*XMN2*SQRTF(T2(N))
147 BMU2 = 1.18E-05*716.*(T2(N)/500.)*SQRTF(T2(N)/500.)/(T2(N)+216.)
    RN2(N)=RHO2*V2*ELH*32.174/BMU2
    IF (RN2(N)-RNCR) 148,149,149
148 CH = .332
    YH = .5
    RH = .85
    GO TO 150
149 CH = .0296
    YH = .8
    RH = .9
150 D1 = -94.38
    D2 = .2331
    D3 = 8.4E-06
    H2 = T2(N)**2*D3+T2(N)*D2+D1
    HAW = V2**2*RH/5.012E+04+H2
    IF (TS(N)-TTS(20)) 151,151,217
151 I = 0
152 I = I+1
    IF (TS(N)-TTS(I)) 154,153,152
153 ES = ES(I)
    GO TO 155
154 ES = ES(I-1)+(TS(N)-TTS(I-1))*(ES(I)-ES(I-1))/(TTS(I)-TTS(I-1))
155 J = 0
156 J = J+1
    IF (TS(N)-TTS(J)) 158,157,156
157 CPS = CPS(J)
    GO TO 159

```

TABLE I (CONT'D)

```

158 CPS =CPS(J-1)+(TS(N)-TTS(J-1))*(CPS(J)-CPS(J-1))/(TTS(J)-TTS(J-1))
159 HS = TS(N)**2*D3+TS(N)*D2+D1
    HR = .22*(HAW-H2)+.5*(HS-H2)+H2
    D4 = 400.
    D5 = 3.829
    D6 = -1.978E-04
    TAW(N)=HAW**2*D6+HAW*D5+D4
    TH = HR**2*D6+HR*D5+D4
    BMUH = 1.18E-05*716.*(TH/500.)*SQRTF(TH/500.)/(TH+216.)
    RHOH = P2/(53.3*TH)
    RNH = RHOH*V2*ELH/BMUH
    SBC = 4.758E-13
    DTS(N) = (CH*BMUH*EXPF(YH*LOGF(RNH))*PRP*(HAW-HS))/(ELH*RHOS*DELTA
1S*CPS)-(SBC*ES*(TS(N)**4-T2(N)**4))/(DELTAS*RHOS*CPS)
160 DTSL(1) = DTS(N)
    DO 173 L=1,3
    TSA = TS(N)+DTSL(L)*DELTAH/2.
    HS = TSA**2*D3+TSA*D2+D1
    HR = .22*(HAW-H2)+.5*(HS-H2)+H2
    TH = HR**2*D6+HR*D5+D4
    BMUH = 1.18E-05*716.*(TH/500.)*SQRTF(TH/500.)/(TH+216.)
    RHOH = P2/(53.3*TH)
    RNH = RHOH*V2*ELH/BMUH
    DTSL(L+1) = (CH*BMUH*EXPF(YH*LOGF(RNH))*PRP*(HAW-HS))/(ELH*RHOS*DE
1LTAS*CPS)-(SBC*ES*(TSA**4-T2(N)**4))/(DELTAS*RHOS*CPS)
    IF (L-2) 170,171,172
170 DTA = DTSL(L+1)
    GO TO 173
171 DTB = DTSL(L+1)
    DTSL(L+1) = 2.*DTSL(L+1)
    GO TO 173
172 DTC = DTSL(L+1)
173 CONTINUE
    Q(N) = DTS(N)*CPS*RHOS*DELTAS*3600.
    CPA = .06856*(3.5+((5526./TS(N))**2*EXPF(5526./TS(N))/(-1.+EXPF(55
126./TS(N))))**2))
    HTC(N) = CPA*CH*BMUH*EXPF(YH*LOGF(RNH))*PRP*3600./ELH
200 TS(N+1) = TS(N)+(DELTAH/6.)*(DTS(N)+2.*DTA+2.*DTB+DTC)
    BC=ESA*SBC*3600.
    HMAX=HTC(1)
    DO204 I=2,K
    IF(HMAX-HTC(I))203,204,204
203 HMAX=HTC(I)
204 CONTINUE
    TAWMAX=TAW(1)
    DO206 I=2,K
    IF(TAWMAX-TAW(I))205,206,206
205 TAWMAX=TAW(I)
206 CONTINUE
    IF(TAWMAX-4000.)207,209,219
207 IF(TAWMAX-2000.)208,210,209
208 IF(TAWMAX-1000.)211,211,210
209 BH=EXPF(.25*LOGF(500./HMAX))*EXPF(.25*LOGF(BC/2.0E-09))
    DK=500./HMAX
    TAWR=4000.
    GOTO212
210 BH=EXPF(.25*LOGF(500./HMAX))*EXPF(.25*LOGF(BC/2.0E-09))*595
    DK=2.*500./HMAX
    TAWR=2000.
    GOTO212

```

TABLE 1 (CONT'D)

```

211 BH=EXPF(.25*LOGF(500./HMAX))*EXPF(.25*LOGF(BC/2.0E-09))* .354
    DK=4.*500./HMAX
    TAWR=1000.
212 TSMAX=TS(I)
    DO225 I=2,K
    IF(TSMAX-TS(I))224,225,225
224 TSMAX=TS(I)
225 CONTINUE
    IF(TSMAX-4000.)226,228,219
226 IF(TSMAX-2000.)227,229,228
227 IF(TSMAX-1000.)230,230,229
228 TSR=4000.
    GOTO231
229 TSR=2000.
    GOTO231
230 TSR=1000.
231 DO232 I=1,K
    TSP(I)=TS(I)*99.5/TSR
    TAWP(I)=TAW(I)*99.5/TAWR
232 HP(I)=HTC(I)*99.5/HMAX
    WRITEOUTPUTTAPE3,220,ELH
220 FORMAT(11HA,1X,5HELH =,E11.4)
222 WRITEOUTPUTTAPE3,223,BH
223 FORMAT(2X,5HBH =,E11.4)
    WRITEOUTPUTTAPE3,233,DK
233 FORMAT(2X,5HDK =,E11.4)
    WRITEOUTPUTTAPE3,201,(THETA(I),H(I),VA(I),ALFD(I),XMN(I),TS(I),
    1DTS(I),TAW(I),I2(I),RN2(I),I=1,K)
201 FORMAT(3X,8HTIME=SEC,6X,6HALT=FT,5X,7HVEL=FPS,5X,8HALFD=DEG,7X,2H
    1MN,9X,4HTS=R,6X,7HDTS=RPS,6X,5HTAW=R,8X,4HT2=R,8X,3HRN2/1HA,10E12.
    24/(1X,10E12.4))
    WRITEOUTPUTTAPE3,202,(THETA(I),HTC(I),Q(I),TAWP(I),HP(I),TSP(I)
    1,I=1,K)
202 FORMAT(1HA,2X,8HTIME=SEC,7X,3HHTC,10X,1HQ,10X,4HTAWP,9X,2HHP,9X,3
    1HTSP/1HA,6E12.4/(1X,6E12.4))
    GOTO5
219 WRITEOUTPUTTAPE3,221
221 FORMAT(23H TAW OR TS OUT OF RANGE)
    GOTO215
213 WRITE OUTPUT TAPE 3,214
214 FORMAT(28X,21HALTITUDE OUT OF RANGE)
    GO TO 215
217 WRITEOUTPUTTAPE3,218
218 FORMAT(40H SKIN TEMPERATURE EXCEEDS RANGE OF TABLE)
215 CALL EXIT
216 END

```

7. Error printout if an excess altitude is inadvertently entered with the data
8. Error printout if the skin temperature exceeds the maximum temperature of the interpolation table
9. Error printout if the adiabatic wall temperature (T_{aw}) or skin temperature (T_s) exceeds 4000°R
10. Scale measurements of the heat transfer coefficient (h), the adiabatic wall temperature (T_{aw}), and the skin temperature (T_s) for the heat rate computer

The following information is required as data for the program:

1. Number of time points, K
2. Flight profile information (inserted as five data points per card)
 - a. Time (THETA)
 - b. Altitude (H)
 - c. Velocity (VA)
 - d. Angle of attack (ALFD)
3. Material specific heat and emissivity versus temperature (20 points per curve, five data points per card)
 - a. Temperature range (TTS)
 - b. Material specific heat (CPS)
 - c. Skin emissivity (ES)

The previous data is required only once for each flight profile. The following data is required for each point under consideration:

1. Beginning skin temperature ($TS(1)$)
2. Prandtl Number raised to the $-(2/3)$ power (PRP)
3. Critical Reynolds Number (RNCR)
4. Wedge angle, which is one-half the total included angle (D7)
5. Distance from the leading edge to the point in question (ELH)
6. Material density (RHOS)

FDL TDR 64-112

Part I

7. Material thickness (DELTA S)
8. Time increment (DELTA H)
9. Average skin emissivity for expected temperature range (ESA)

The results of the computer program are printed in tabulated form with headings at the top of each column. The following results are printed adjacent to the corresponding time:

1. Time
2. Altitude
3. Velocity
4. Angle of attack
5. Local Mach Number
6. Skin temperature
7. Derivative of skin temperature with respect to time
8. Adiabatic wall temperature
9. Local atmospheric temperature aft of the shock wave
10. Local Reynolds Number aft of the shock wave
11. Heat transfer coefficient
12. Total heat transferred
13. Paper tape punch values for the adiabatic wall temperature, skin temperature, and the heat transfer coefficient

The tabulated results are headed by a printout of the location of the point in question, the B-h potentiometer setting, and the demand gain. All results are given to four significant digits.

The information obtained from the digital computer program is used to design the laboratory test setup for simulating the aerodynamic heating. The heat transferred and the temperature rise rate are used to determine power requirements, and the heat transfer coefficient and the adiabatic wall temperature are used as inputs to the heat rate computer.

APPENDIX II

SPECIAL PURPOSE HEAT RATE COMPUTER

The General Electric Heat Rate Computer can calculate the amount of energy required to simulate aerodynamic heating of forty airframe test areas and controls the flow of electrical energy used to simulate these effects. The computer has magnetic drum storage for 300 points per channel. Actual computing is accomplished by one closed loop analog computer which is shared with the forty information channels by means of multiplexing.

The heat rate computer is designed for three modes of operation: (1) the power feedback mode (YEI); (2) the derivative mode (dT_s/dt); and (3) the temperature versus time mode (T_s/t). In the power feedback mode the computer operates on the following equation:

$$\Delta e = G_1 \left[h (T_{aw} - T_s) - BT_s^4 - YEI \right]$$

In the derivative mode the computer operates on this equation:

$$\Delta e = G_2 \left[h (T_{aw} - T_s) - BT_s^4 - cw\tau \frac{dT_s}{dt} \right]$$

In the temperature versus time mode the computer does no calculation but operates only as a controller, comparing the test temperature with the desired temperature programmed on the computer drum. The equation for this mode is expressed as follows:

$$\Delta e = G_3 (T_{sp} - T_{st})$$

where T_{sp} is the programmed temperature and T_{st} is the specimen temperature.

The heat rate computer provides the error signal to the ignitron units, which provide electrical power for the test setup. The design of the power source is very important for good computer control and test results. The power source must provide sufficient power, but not an excess of power. An excess amount of power will usually result in poor computer control and a higher temperature than is desired. The power required is based on either the greatest temperature rise rate required or the power required to maintain the maximum temperature. Additional power is required to allow for the efficiency of the test setup. The efficiencies of most test setups in this laboratory range between approximately 20 and 50 percent. Therefore, a power availability of about two to five times the calculated required power will usually result in satisfactory computer control.

SCALING

In the power feedback (YEI) and derivative (dT_s/dt) modes the computer operates in a closed loop which consists of a demand side and a feedback side. The demand side is represented by the following portion of the design equations:

$$h (T_{aw} - T_s) - B T_s^4$$

The feedback side is represented by YEI for the power feedback mode, and $cw\tau \frac{dT_s}{dt}$ for the derivative mode. Both sides of the closed loop must be scaled properly for satisfactory test results. A schematic diagram of the power feedback and derivative modes is shown in Figure 5.

DEMAND SCALING

The demand scaling is identical for both the power feedback mode (YEI) and the derivative mode (dT_s/dt). The factors involved are the heat transfer coefficient curve (h), the adiabatic wall temperature curve (T_{aw}), the B-h SCALE FACTOR potentiometer, the skin temperature range selector switch, the thermocouple selector switch, the K SCALE FACTOR switch, the power range selector switch, and the mode selector switch.

The mode selector switch has three positions: (1) EI, for power feedback mode, (2) dT_s/dt, for derivative mode, and (3) T_s/t, for the temperature versus time mode.

The thermocouple selector switch is set to correspond with the type of thermocouple used on the test specimen. Positions are available for thermocouples of: Iron-Constantan; Chromel-Constantan; Chromel-Alumel; and Platinum-Platinum, 10-percent Rhodium.

The skin temperature range selector switch has positions of 1000°, 2000°, and 4000°R. This switch should be set on the closest range that exceeds the maximum adiabatic wall temperature stored on the drum or the maximum skin temperature, whichever is greatest.

The K SCALE FACTOR switch has settings of 1, 10, and 100 available. Although this switch is usually left at a setting of 1, it may be used to obtain more demand gain than is available in the inherent gain obtained in the scaling of the h and T_{aw} curves.

The EI RANGE switch has settings that represent an electrical load of 72, 144, 360, and 720 KW. In the derivative mode (dT_s/dt) this switch has no control feature and it should be set at the nearest range that exceeds the connected load when the full voltage (580 volts) is applied. Each power range also has a gain associated with it. These gains are important in the power feedback mode (YEI), where the EI RANGE switch is a part of the feedback mode circuitry. The manipulation of this switch in the power feedback mode will be discussed in the section on feedback scaling.

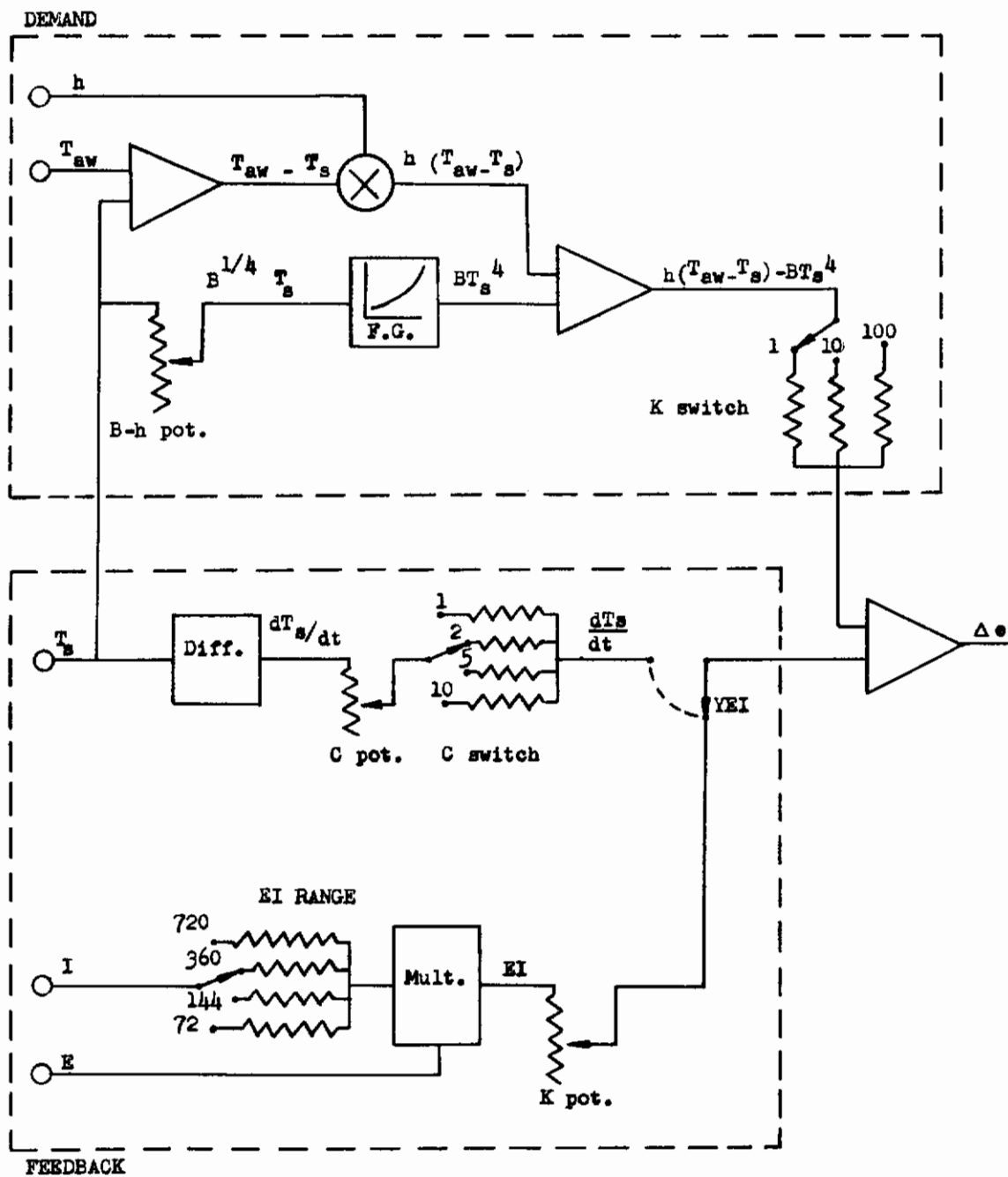

Figure 5. Schematic Diagram for Power Feedback and Derivative Modes

One heat transfer coefficient curve per channel is stored on the magnetic drum after being inserted by paper tape. The curve is scaled according to the following equation:

$$h \text{ tape value} = 99.5 \left(\frac{h}{h_{\max}} \right)$$

The IBM digital computer program performs this scaling operation with the exception of changing the third digit of each point to "0" or "5". The third digit of each point must be rounded off to 0 or 5 before the heat rate computer will properly accept the points.

The heat rate computer has provisions for as many as ten adiabatic wall temperature curves. These curves are also coded on paper tape and stored on the magnetic drum. The scaling performed by the IBM digital computer program follows this expression:

$$T_{\text{aw}} \text{ tape value} = 99.5 \left(\frac{T_{\text{aw}}}{T_s \text{ range}} \right)$$

Again the third digit must be manually rounded off to 0 or 5.

The maximum value of the heat transfer coefficient and the T_s range selection determine the inherent demand gain, K_D , obtained with the scaling of h and T_{aw} . The equation for determining the inherent demand gain is as follows:

$$K_D = \left(\frac{500}{h_{\max}} \right) \left(\frac{4000}{T_s \text{ range}} \right)$$

This calculation is also provided by the IBM digital computer program. Best results are obtained if h does not exceed 500 and the demand gain does not exceed 10.

The B-h SCALE FACTOR potentiometer is a ten-turn potentiometer that is designed to allow for the radiation losses from the test specimen. Each turn of this potentiometer represents a value of 1.0. The potentiometer setting is determined by the following expression:

$$B-h = \left(\frac{B}{2 (10)^{-9}} \right)^{1/4} \left(\frac{T_s \text{ range}}{4000} \right)^{3/4} \left(\frac{500}{h_{\max}} \right)^{1/4}$$

The term "B" in this expression is the product of the specimen emissivity and the Stefan-Boltzmann constant. The IBM digital computer program calculates the B-h SCALE FACTOR potentiometer setting using an average emissivity over the expected temperature range of the specimen.

FEEDBACK SCALING

Feedback scaling in the power feedback (YEI) mode requires proper manipulation of the EI RANGE switch and the K SCALE FACTOR potentiometer. Feedback gain is obtained through the use of the power range selector switch. The power ranges of 72, 144, 360, and 720 KW have associated gains of 10, 5, 2, and 1, respectively. Therefore,

the required gain, as well as the required power, must be considered in arriving at the power setting of the EI RANGE switch. The utilization of this switch will be discussed in the scaling examples.

The K SCALE FACTOR potentiometer is a ten-turn potentiometer with each rotation of the dial representing a value of 0.1. This potentiometer is used to attenuate the feedback signal to allow for the efficiency of the test setup. When the power range selector switch is set so the feedback gain is the same as the demand gain, the setting for the K SCALE FACTOR potentiometer is the efficiency of the channel (η) divided by the area (A) covered by the channel. However, the EI RANGE switch and the K SCALE FACTOR potentiometer may be combined in such a way that almost unlimited values of feedback gain may be obtained. The combination of these two controls is covered in the scaling examples.

In order to arrive at the proper K SCALE FACTOR potentiometer setting, the efficiency of the test setup must be known. This efficiency is usually determined by a constant power efficiency test. This test may be run on a simulated test setup, but should be conducted on the actual test setup, if feasible. The efficiency test should be designed to require a constant power that will give a specimen temperature rise rate that is comparable to that expected in the actual simulation test.

The efficiency test is conducted in conjunction with the data processing system. The data section has a program written for the CDC 1604 digital computer based on the following equation:

$$\frac{\eta}{A} = \left(\frac{c w \tau}{E I} \right) \left(\frac{\Delta T_s}{\Delta T} \right) (1.0542)$$

This equation is legitimate as long as it is applied to a portion of the temperature curve where the rise rate is relatively constant. To prepare the efficiency program, the data section must be provided the following information: material thickness (τ), material density (w), a curve of material specific heat versus temperature, thermocouple type, and the power range to be used. The 1604 computer is then operated on-line with the heat rate computer to provide the temperature, temperature rise rate, power absorbed by the specimen, total power required, and the efficiency per unit area. The efficiency per unit area is then used in setting the K SCALE FACTOR potentiometer.

Three examples of using the EI RANGE switch and the K SCALE FACTOR potentiometer in the feedback circuit of the power feedback mode (YEI) will now be shown. Only the feedback scaling will be given here. Examples of demand scaling are shown in the discussion of derivative mode (dT_s/dt) scaling.

Example 1:

Given: $K_D = 2$

Power required = 300 KW

$\eta/A = .312$ (determined from an efficiency test)

In this case the EI RANGE switch should be set on a power range of 360 KW since this is the nearest position available that exceeds the power requirement. The 360-KW position also has an associated gain of 2, which in this case matches the demand gain. Therefore, for this example, the K SCALE FACTOR potentiometer would be set at the value of η/A , or .312. This value is 3.12 turns of the potentiometer dial.

Example 2:

$$\text{Given: } K_D = 2$$

$$\text{Power required} = 100 \text{ KW}$$

$$\eta/A = .247 \text{ (determined from an efficiency test)}$$

In this example the EI RANGE switch may be placed at 144 or 360 KW. The 144-KW range would be sufficient, but the associated gain of 5 does not match the demand gain. If the 360-KW position were used, the gains would match and the K SCALE FACTOR potentiometer would be set at the value of η/A . Optimum utilization of the full power range would be obtained with the 144-KW setting. However, the K SCALE FACTOR potentiometer setting must be reduced to compensate for the difference between the demand gain and the feedback gain. This can be done by multiplying the η/A value for matched gains by the ratio of the demand gain to the gain associated with the chosen power range. The new setting for the K SCALE FACTOR potentiometer in this case would then become:

$$K_{\text{pot}} = \eta/A \left(\frac{K_D}{\text{EI gain}} \right)$$

$$= (.247) \left(\frac{2}{5} \right)$$

$$K_{\text{pot}} = .0988$$

Example 3:

$$\text{Given: } K_D = 4.72$$

$$\text{Power required} = 100 \text{ KW}$$

$$\eta/A = .417 \text{ (determined from an efficiency test)}$$

In this example the gain value is such that no power range selection will match it. A power range of 144 KW, with an associated gain of 5, may be used. The η/A value for matched gains must then be modified:

$$K_{\text{pot}} = .417 \left(\frac{K_D}{\text{EI gain}} \right)$$

$$= .417 \left(\frac{4.72}{5} \right)$$

$$K_{\text{pot}} = .394$$

Contrails

FDL TDR 64-112

Part I

A general expression for finding the proper K SCALE FACTOR potentiometer setting can be derived from the previous examples. This expression is:

$$K_{pot} = \frac{\eta}{A} \left(\frac{K_D}{EI \text{ gain}} \right)$$

where EI gain is the associated gain of the chosen power range. This equation may be used as long as the calculated value does not exceed 1.0. For instance if the demand gain is 5 and the η/A is .25, the EI RANGE switch may be set at 360 KW, or a gain of 2. The potentiometer setting would then become:

$$K_{pot} = (.25) \left(\frac{5}{2} \right)$$
$$K_{pot} = .625$$

However, under these conditions the EI RANGE switch could not be placed at 720 KW, or a gain of 1, because the potentiometer setting would then become:

$$K_{pot} = (.25) \left(\frac{5}{1} \right)$$
$$K_{pot} = 1.25$$

which is impossible to set on the potentiometer. Therefore, the power range and the demand gain must be combined in a way such that the K SCALE FACTOR potentiometer calculation does not exceed 1.0.

The feedback scaling for the derivative mode (dT's/dt) is very similar to that of the power feedback mode. In the derivative mode the C SCALE FACTOR switch and the C SCALE FACTOR potentiometer are used to obtain the required feedback gain. The C SCALE FACTOR switch is a four-position switch with gain settings of 1, 2, 5, and 34.125*. The C SCALE FACTOR potentiometer is a ten-turn potentiometer with each rotation of the dial representing a value of 1.0. When the C SCALE FACTOR switch is set on a gain that matches the demand gain, the proper setting for the C SCALE FACTOR potentiometer is $cw\tau$. However, the C SCALE FACTOR switch and the C SCALE FACTOR potentiometer can be combined to give almost any value of feedback gain. The use of these two controls is discussed in the scaling examples.

*This gain is obtained by setting the C SCALE FACTOR switch at 10. The switch was originally designed with a gain of 10, but a resistor was changed during computer modifications to give the new gain of 34.125. This position is now intended for the temperature versus time mode only, but it may still be used in the derivative mode.

Two examples of derivative mode scaling will now be given.

Example 4:

Given : $h_{max} = 200 \text{ BTU/hr-ft}^2\text{-}^\circ\text{R}$
 $T_{s \text{ range}} = 2000^\circ\text{R}$
 K SCALE FACTOR switch = 1
 $\epsilon = .6$
 $\sigma = 1.73 \times 10^{-9} \text{ BTU/hr-ft}^2\text{-}^\circ\text{R}^4$
 $c = .12 \text{ BTU/lb-}^\circ\text{R}$
 $w = 500 \text{ lb/ft}^3$
 $\tau = .06 \text{ in.} = .005 \text{ ft}$

First determine the inherent demand gain, K_D :

$$K_D = \left(\frac{500}{h_{max}} \right) \left(\frac{4000}{T_{s \text{ range}}} \right)$$

$$= \left(\frac{500}{200} \right) \left(\frac{4000}{2000} \right)$$

$$K_D = 5$$

Now determine the setting for the B-h SCALE FACTOR potentiometer:

$$B-h = \left(\frac{B}{2 \times 10^{-9}} \right)^{1/4} \left(\frac{T_{s \text{ range}}}{4000} \right)^{3/4} \left(\frac{500}{h_{max}} \right)^{1/4}$$

$$B = \epsilon \sigma$$

$$= (1.73 \times 10^{-9}) (.6)$$

$$B = 1.038 \times 10^{-9}$$

$$B-h = \left(\frac{1.038 \times 10^{-9}}{2 \times 10^{-9}} \right)^{1/4} \left(\frac{2000}{4000} \right)^{3/4} \left(\frac{500}{200} \right)^{1/4}$$

$$= (.519)^{1/4} (.500)^{3/4} (2.5)^{1/4}$$

$$= (.849) (.595) (1.258)$$

$$B-h = .635$$

Now the feedback side must be scaled. Since the demand gain, K_D , is 5, the C SCALE FACTOR switch can conveniently be set on a value of 5. Under these conditions the C SCALE FACTOR potentiometer is set at a value of $cw\tau$.

$$C_{pot} = cw\tau$$

$$= (12)(500)(.005)$$

$$C_{pot} = .300$$

Example 5:

Given :

$$h_{max} = 240 \text{ BTU/hr-ft}^2\text{-}^\circ\text{R}$$

$$T_{s \text{ range}} = 2000^\circ\text{R}$$

$$K \text{ SCALE FACTOR switch} = 1$$

$$\epsilon = .6$$

$$\sigma = 1.73 \times 10^{-9} \text{ BTU/hr-ft}^2\text{-}^\circ\text{R}^4$$

$$c = .12 \text{ BTU/lb-}^\circ\text{R}$$

$$w = 500 \text{ lb/ft}^3$$

$$\tau = .06 \text{ in.} = .005 \text{ ft}$$

The calculations for this example are as follows:

$$K_D = \left(\frac{4000}{2000} \right) \left(\frac{500}{240} \right)$$

$$K_D = 4.17$$

$$B = \epsilon\sigma = (.6)(1.73 \times 10^{-9})$$

$$B = 1.038 \times 10^{-9}$$

$$B-h = \left(\frac{B}{2 \times 10^{-9}} \right)^{1/4} \left(\frac{T_{s \text{ range}}}{4000} \right)^{3/4} \left(\frac{500}{h_{max}} \right)^{1/4}$$

$$= \left(\frac{1.038 \times 10^{-9}}{2 \times 10^{-9}} \right)^{1/4} \left(\frac{2000}{4000} \right)^{3/4} \left(\frac{500}{240} \right)^{1/4}$$

$$= (.519)^{1/4} (.500)^{3/4} (2.08)^{1/4}$$

$$= (.849)(.595)(1.201)$$

$$B-h = .607$$

$$cw\tau = (.12)(500)(.005)$$

$$cw\tau = .300$$

In this case there is not a convenient setting of the C SCALE FACTOR switch that will match the demand gain of 4.17. However, the C SCALE FACTOR switch may be set at 5. The $cw\tau$ calculation must now be modified so the feedback gain will match the demand

gain. This can be done by multiplying $cw\tau$ by the ratio of the demand gain to the C SCALE FACTOR switch position. Therefore, the setting for the C SCALE FACTOR potentiometer will be:

$$\begin{aligned}C_{pot} &= cw\tau \left(\frac{K_D}{C_{switch}} \right) \\ &= (.3) \left(\frac{4.17}{5} \right) \\ C_{pot} &= .250\end{aligned}$$

The C SCALE FACTOR switch could also be set at 1. In this case the C SCALE FACTOR potentiometer setting would be:

$$\begin{aligned}C_{pot} &= (.30) \left(\frac{4.17}{1} \right) \\ C_{pot} &= 1.251\end{aligned}$$

From the two previous examples the following general expression can be derived for determining the setting for the C SCALE FACTOR potentiometer:

$$C_{pot} = cw\tau \left(\frac{K_D}{C_{switch}} \right)$$

This expression may be used as long as the calculated setting does not exceed 10.

TEMPERATURE VS. TIME MODE

In the temperature versus time mode the heat rate computer is used only as a controller. The error signal is obtained from the difference between the programmed temperature and the specimen temperature. The error signal is proportional to the amount the specimen temperature drops below the desired temperature. The following proportional bands are available for the appropriate temperature range:

Scale	Proportional Bands
1000°R	10, 20, 30, 40, 50, 60, 70, 80, 90, 100°R
2000°R	20, 40, 60, 80, 100, 120, 140, 160, 180, 200°R
4000°R	40, 80, 120, 160, 200, 240, 280, 320, 360, 400°R

Each proportional band figure means that a specimen temperature lag of that value will result in the full error signal of 50 volts.

The power arrangement is extremely important in the temperature versus time mode. The temperature program should be designed so that no step increment will require more than one-fourth of the total available load. This means that for smooth computer control the ratio of the power output per volt of Δe should be held to a minimum. A

Contrails

FDL TDR 64-112

Part I

proportional band should be chosen such that the maximum step increment will demand not more than one-half kilowatt per lamp. If this proportional band is unsatisfactory, some trial runs may be necessary to decide which proportional band gives the best combination of good test results and smooth control.

The demand signal in the temperature versus time mode is obtained in the scaling of the specimen temperature by the digital computer program. The skin temperature is scaled according to the following equation:

$$T_s \text{ tape value} = 99.5 \left(\frac{T_s}{T_s \text{ range}} \right)$$

As in the previous cases the third digit of each point must be rounded off to 0 or 5.

The only controls in the feedback circuit of the temperature versus time mode are the C SCALE FACTOR potentiometer and the C SCALE FACTOR switch. With the K SCALE FACTOR switch in the demand side set at 10, and the C SCALE FACTOR switch set at a gain of 34.125*, the computer technicians set the C SCALE FACTOR potentiometer so that a temperature lag equal to the chosen proportional band will result in an error signal of 50 volts. This is accomplished by first inserting the maximum desired temperature in the demand circuit. A millivolt signal is then manually inserted in the feedback circuit to represent the thermocouple signal equal to the maximum desired temperature minus the chosen proportional band. The C SCALE FACTOR potentiometer is then adjusted until the error signal is 50 volts. The demand and feedback circuits are now considered "balanced."

To eliminate any lag in the temperature versus time mode, the amount of demand must be increased. This may be done in one of two ways. (1) each point of the demand curve may be multiplied by this factor:

$$\frac{T_s \text{ max} + \text{P. B. Offset}}{T_s \text{ max}}$$

Or, (2) the C SCALE FACTOR potentiometer setting at balanced conditions may be divided by this factor:

$$\frac{T_s \text{ max}}{T_s \text{ max} - \text{P. B. Offset}}$$

The proportional band offset may be determined from the power arrangement. However, if the calculated value does not give satisfactory test results, a new proportional band offset can be easily inserted by using the second method.

*This gain is obtained by setting the C SCALE FACTOR switch at the indicated value 10.

FDL TDR 64-112
Part I

The use of these two factors will be shown in the following example of temperature versus time scaling. In this case it is assumed that the proportional band offset is equal to the chosen proportional band.

Example 6:

Given Desired maximum $T_s = 1600^\circ R$
 T_s range switch = $2000^\circ R$
 Proportional band = P. B. Offset = $80^\circ R$

When using the first method, each point of the temperature curve would be multiplied by the following factor:

$$\begin{aligned}\frac{T_s \text{ max} + \text{P. B. Offset}}{T_s \text{ max}} &= \frac{1600 + 80}{1600} \\ &= \frac{1680}{1600} \\ &= 1.05\end{aligned}$$

In preparing the computer for this method, the technician would insert a voltage in the demand side that would represent $1680^\circ R$, and a voltage representing $1600^\circ R$ would be applied to the feedback circuit. The C SCALE FACTOR potentiometer would then be adjusted so the error signal would be 50 volts.

Suppose for illustration purposes the C SCALE FACTOR potentiometer setting was .495. If the second method was used, the C SCALE FACTOR potentiometer setting would be divided by this factor:

$$\begin{aligned}\frac{T_s \text{ max}}{T_s \text{ max} - \text{P. B. Offset}} &= \frac{1600}{1600 - 80} \\ &= \frac{1600}{1520} \\ &= 1.053\end{aligned}$$

The potentiometer setting would then become:

$$\begin{aligned}C_{\text{pot}} &= \frac{.495}{1.053} \\ C_{\text{pot}} &= .470\end{aligned}$$

By using the second method, the original temperature curve as scaled by the digital computer program can be used without alteration. This method also provides a method of easily changing from one proportional band offset to another if a trial and error system is used to determine the best proportional band offset.