

AFFDL-TR-66-91

**A PROTOTYPE PERIPHERAL VISION AIRCRAFT
ATTITUDE DISPLAY**

WILLIAM R. WILLIAMSON

**Distribution of this document
is unlimited**

FOREWORD

This report was prepared by Link Division, General Precision, Inc. for the Air Force on Contract Number AF 33(615)2895, Project 6190, "The Air Force Control-Display Program," for which Mr. John H. Kearns III served as Project Engineer. The effort was administrated under the direction of the Flight Control Division, Air Force Flight Dynamics Laboratory, Wright-Patterson Air Force Base, as a part of Task Number 619004, "Control-Display Evaluation". Mr. Robert R. Davis served as Technical Monitor. The contractor's assigned job number for this study is 64-132.

The System was designed and constructed by Mr. Wolfred Greenberg and Mr. H.G. Ledbetter. This report was prepared during April 1965 by Mr. W. R. Williamson, Senior Engineer, General Precision, Inc., Link Division.

This is one of a succession of reports presenting results achieved in a continuing heuristic investigation in the area of control-display being conducted under Project 6190.

Manuscript released by the author June 1966 for publication as an RTD Technical Report.

This technical report has been reviewed and is approved.

Loren A. Anderson

LOREN A. ANDERSON, Major, USAF
Chief, Control Systems Research Branch
Flight Control Division

ABSTRACT

An instrument is described for presenting attitude information to the pilot in such a manner that he may maintain an awareness of his attitude through Peripheral Vision without the necessity for looking directly at a specific instrument. The system does this by projecting a line of light on the aircraft instrument panel and moving it in a manner similar to the motion of the real horizon. A design criteria and a detailed engineering description of the working model are also presented.

Contrails

TABLE OF CONTENTS

SECTION	PAGE
I INTRODUCTION	1
II TECHNICAL DESCRIPTION	2
III DESIGN DETAILS	6
Pitch System	6
Roll System	6
Heading System	6
Optical System	6
IV SUMMARY AND CONCLUSION	9
Summary	9
Conclusion	9
V REFERENCES	10

ILLUSTRATIONS

FIGURE		PAGE
1	Peripheral Vision Display Block Diagram	3
2	Heading and Roll Mechanisms	4
3	Side View of Projector Assembly	7
4	Top View of Projector Assembly	8
5	Pitch System Schematic	11
6	Roll System Schematic	12

SECTION I

INTRODUCTION

Often during instrument flight, the pilot must look away from the instrument panel for short periods. Not infrequently the attitude of the aircraft changes gradually without the pilot's cognizance while his attention is diverted. Under contract conditions, the pilot can normally detect attitude changes through peripheral vision motion cues even if his attention is directed into the cockpit.

Early in 1960, this Laboratory began its first effort to extend peripheral vision motion cues into instrument flight. A system was designed and built which projects attitude information in the form of a movable light line on the aircraft instrument panel. The purpose of the light line was to extend the horizon line of the attitude director indicator (ADI). The movement of the light line in pitch and roll was made to coincide with that of the ADI horizon line. Although the feasibility of using a project light line to present peripheral vision motion cues was demonstrated, this early system had three severe shortcomings. First, the light source, a mercury vapor lamp, generated excessive heat. Second, the equipment, as originally conceived and built, was not sufficiently

sophisticated to determine the optimum light line dimensions. Finally, the motion cues were restricted to changes about the roll and pitch axis with no provision for the changes in yaw.

Encouraged by the feasibility demonstrated in the early effort, Control Systems Research Branch, Air Force Flight Dynamics Laboratory, began the development work described in this Technical Report. The result of this new work was a functional prototype Peripheral Vision Attitude Display. This display retained the pitch and roll presentations of the earlier system but added light line modulation to provide yaw motion cues.

Because the Simulation Facility is frequently visited by military and commercial pilots of friendly nations, a good cross section of pilot opinion about the value of this type presentation was obtained informally. Initial breadboard exploratory simulation efforts produced encouraging results. Consequently, a fully functional prototype was built and installed in a simulator. This was the system used to obtain subjective reactions of pilots concerning the desirability and requirements for such a device.

SECTION II

TECHNICAL DESCRIPTION

The optical portion of the Peripheral Vision Display was based upon a slide projector kit. The parts from this kit, and a servo-motor-driven mirror assembly, comprise the light beam projection and pitch motion portions of the display. The rest of the system was designed at the Simulation Facility.

Referring to the Block Diagram, Figure 1; the output of the light source is condensed into a beam which passes through a cylindrical lens forming a narrow line of light. This beam is further narrowed by passing it through a slit mask and another condensing lens. It then passes through the focusing projection lens to a mirror and is reflected onto the aircraft instrument panel. The line is rolled about a fixed point by rolling the cylindrical lens and slotted mask. Pitching motion is accomplished by rotating the mirror around an offset axis. The modulated horizontal lines are achieved by rotating a spoked wheel through the light at its source. The spoked wheel drive mechanism "rides" on the rotating cylindrical lens disc so that the modulated lines always appear to move along the projected light line regardless of its orientation.

The light source and beam forming apparatus is comprised of a 100-watt projection bulb, reflector, and two condensing lenses, all from the projection kit.

The line forming cylindrical lens and slotted mask are mounted on an edge driven unit consisting of a 4-in. gear and ring assembly and an offset 4-in. disc, (Figure 2). The lens is mounted on the disc and the slotted mask is mounted on the gear. The gear and ring are staked together, and the cylindrical lens mounting disc is attached by four bolted spacers, thus forming a rigid unit. The device was first attempted with just the gear and lens mounting disc, with small free rotating gears instead of rollers for support. This resulted in an excessive friction load for the roll motor drive unit. Later, when the ring and pulley support rollers were added, satisfactory results were achieved.

The heading synchro-receiver is mounted directly on the roll gear and extends back through a hole in the lens mounting disc. The synchro-receiver provides enough torque to drive the heading spoked wheel directly without a servo-motor. No brush and ring assembly is needed since it is seldom necessary to consider a roll requirement greater than 90 degrees either side of center. Wiring to the heading synchro has enough flexibility (extra length) to permit several continuous 360-degree roll-over maneuvers without winding up to the extent that it applies a load to the mechanism. This is a very unlikely occurrence in simulation equipment.

The edge drive for the roll mechanism is provided by a synchro-receiver servo-motor. The gearing from the motor output shaft to the edge drive gear is a 4:1 step down. The ratio from the edge drive gear to the roll gear is also 4:1 as is the ratio from the edge drive shaft to the roll synchro gear. This results in synchronous rotation of the roll gear and synchro gear. The servo amplifier for the roll system is built into the Universal Flight Trainer computer cabinet and consists of a d.c. operational amplifier, a general purpose 400 cps demodulator, a 3.5-watt magnetic amplifier, and a matching transformer.

The modulated light line is passed through a condensing lens and fast f/1.9 projection lens (both part of the slide projector kit) to the servo driven mirror. The mirror unit consists of a servo motor which drives a mirror tilt platform through a precision worm and wheel gear assembly. The mirror which is mounted approximately 4 feet from the instrument panel, may be positioned through an arc of approximately 45 degrees. Such angular displacement is adequate for normal pitch representation. The axis of rotation of the mirror is offset from the point of light line incidence. The purpose of the offset is to reduce distortion when the line is tilted in the roll plane. Thus, the focal distances of the ends of the tilted line are as equal as possible, consistent, with the

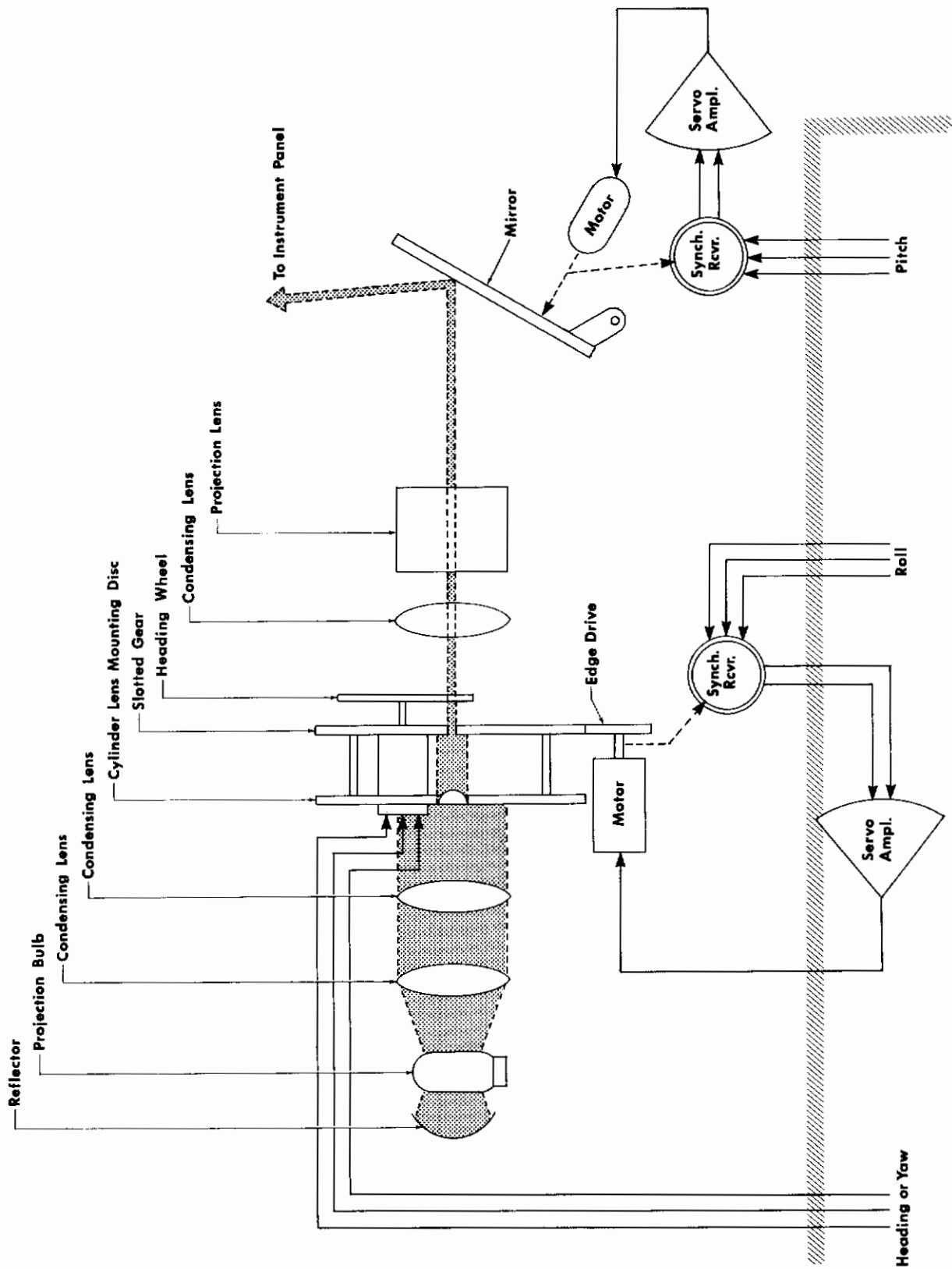

UNIVERSAL FLIGHT TRAINER COMPUTER CABINET

Figure 1. Peripheral Vision Display Block Diagram

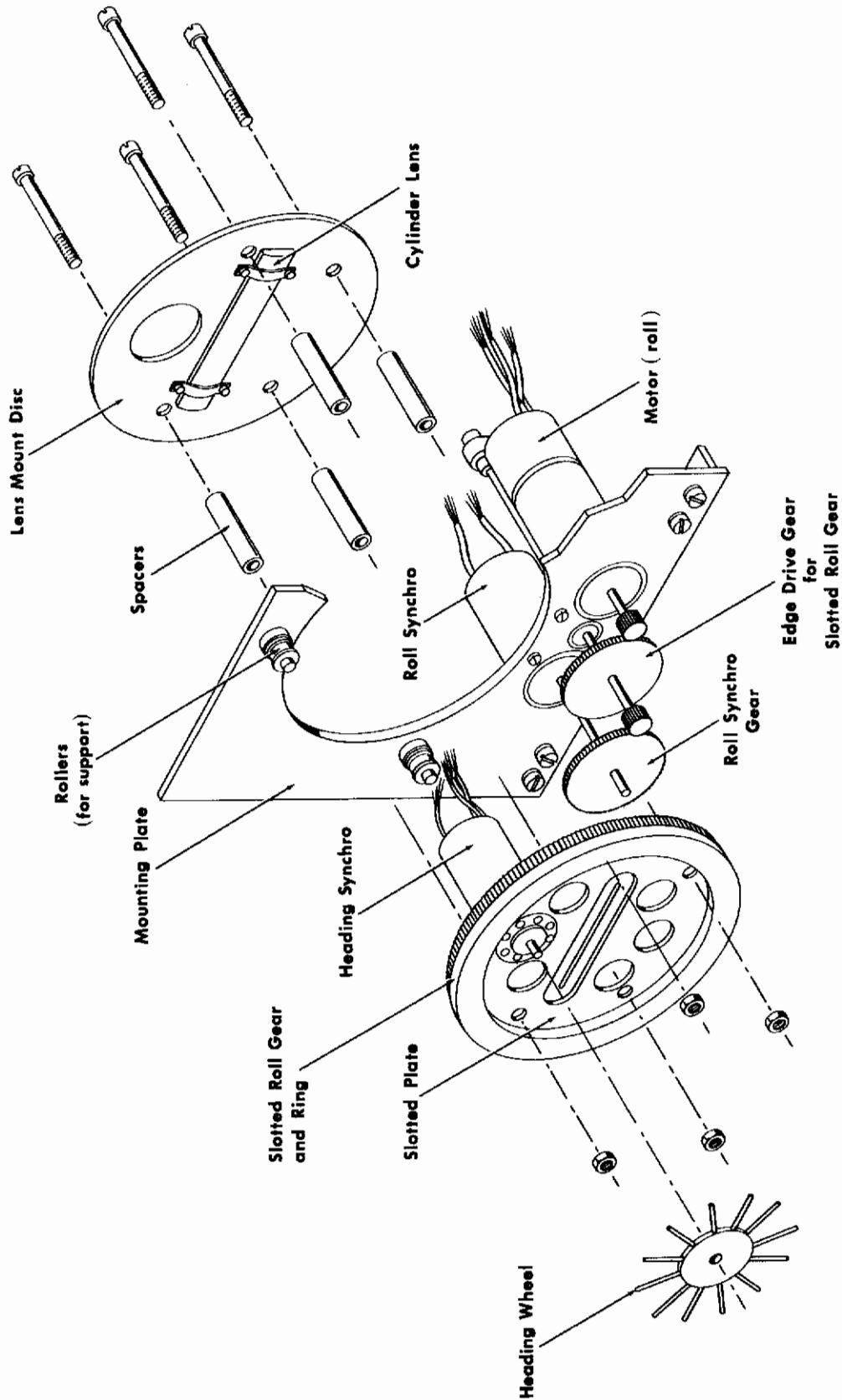

Figure 2. Heading and Roll Mechanisms

physical length of the projector. Ideally, the mirror would be an "infinite" distance from the projector.

The mirror drive, also a synchro servo-mechanism, accepts pitch information from the Universal Flight Trainer in 3-wire synchro form and produces a single phase error signal. A transistorized servo-amplifier is an integral part of the projector in the pitch system.

The overall Peripheral Vision Display is 8 in. wide, 6-1/4 in. high, and 19 in. long. It projects a line approximately two feet wide onto a flat black surface up to five feet away. Pitch movement, as set up in the Universal

Flight Trainer, is scaled so that five degrees is approximately equal to three inches vertical movement of the light line. Power requirements are 115 vac for the Display at 400 cps, 115 vac at 60 cps, and -28 vdc. Power requirements could be reduced somewhat since the 60-cycle power is used only for the projection light bulb and the 400-cycle power for the cooling fan and the servo control. The -28 vdc is for the pitch servo amplifier. Input requirements are for roll, pitch and heading signals. These three signals are in 11.8 vac, 400 cps, 3-wire synchro form. Two switches are used to turn the system on and off; one is for the projector, including heading and roll, and one is for the pitch system, which is external to the projector.

SECTION III

DESIGN DETAILS

PITCH SYSTEM

The servo-motor-driven mirror assembly unit (Figure 3) consists of a 400 cps servo motor, size 18, 115-volt fixed phase, 115/57.5 volt control phase, driving a mirror tilt platform through a precision worm-and-wheel gear assembly. The wheel shaft is fitted with three adjustable cams which operate limit switches. These were not used.

The optically flat mirror (Figure 3) is 3 in. wide, 3-3/4 in. high, and 3/8 in. thick. It may be positioned through an arc of approximately 45 degrees. Overall dimensions are 4-1/2 in. in width, 6 in. in length, and 6 in. in height when the mirror is at the highest point.

A synchro transmitter, size 8, single phase 26-volt rotor, three phase 11.8-volt stator, 400 cps, is used as a synchro control transformer in the mirror-drive servo loop (Figure 3). It accepts the three-wire pitch information from the Universal Flight Trainer. The trainer is a simplified aircraft simulator located in the Flight Dynamics Laboratory Simulation Facility. It is specifically intended for projects of this nature. The synchro transmitter develops an error signal for the motor-driven mirror assembly.

The transistorized servo amplifier, shown in Figure 1, was developed by the Link Group at the Flight Dynamics Laboratory (Reference 2).

ROLL SYSTEM

A 400 cps, servo motor, size 10, 115-volt fixed phase, 60-volt control phase, drives the

roll optics disc mechanism (Figures 2 and 4). This servo motor has a gear head as an integral attachment.

A 400 cps, Torque receiver, size 10, single phase 26 volt rotor, three-phase 11.8-volt stator, is used as the control transformer in the roll servo loop. It accepts the 3-wire roll information from the Universal Flight Trainer and provides the error signal for the roll optics mechanism (Figure 4).

The servo amplifier is composed of spare units existing in the Universal Flight Trainer; a d.c. operational amplifier, a general purpose 400 cps demodulator (Reference 1), a 115-volt, 3.5-watt, 400 cps magnetic amplifier, and a speaker matching transformer for impedance match of the motor (Figure 4).

HEADING SYSTEM

The heading system consists of a spoked wheel (shown in Figure 2 and also laying on top of black box in top view photo Figure 4.) driven by an Autosyn synchro receiver, 400 cps, 26-volt single phase, 11.8-volt 3-phase. There is no servomechanism; the synchro receiver produces enough torque to drive the wheel as a function of the 3-wire heading (or yaw) information from the Universal Flight Trainer.

OPTICAL SYSTEM

The optics in the Peripheral Vision Display (Figures 1 and 2) are composed of a Slide Projector Kit and a cylinder lens. A complete set of instructions for building the projector accompanies the kit.

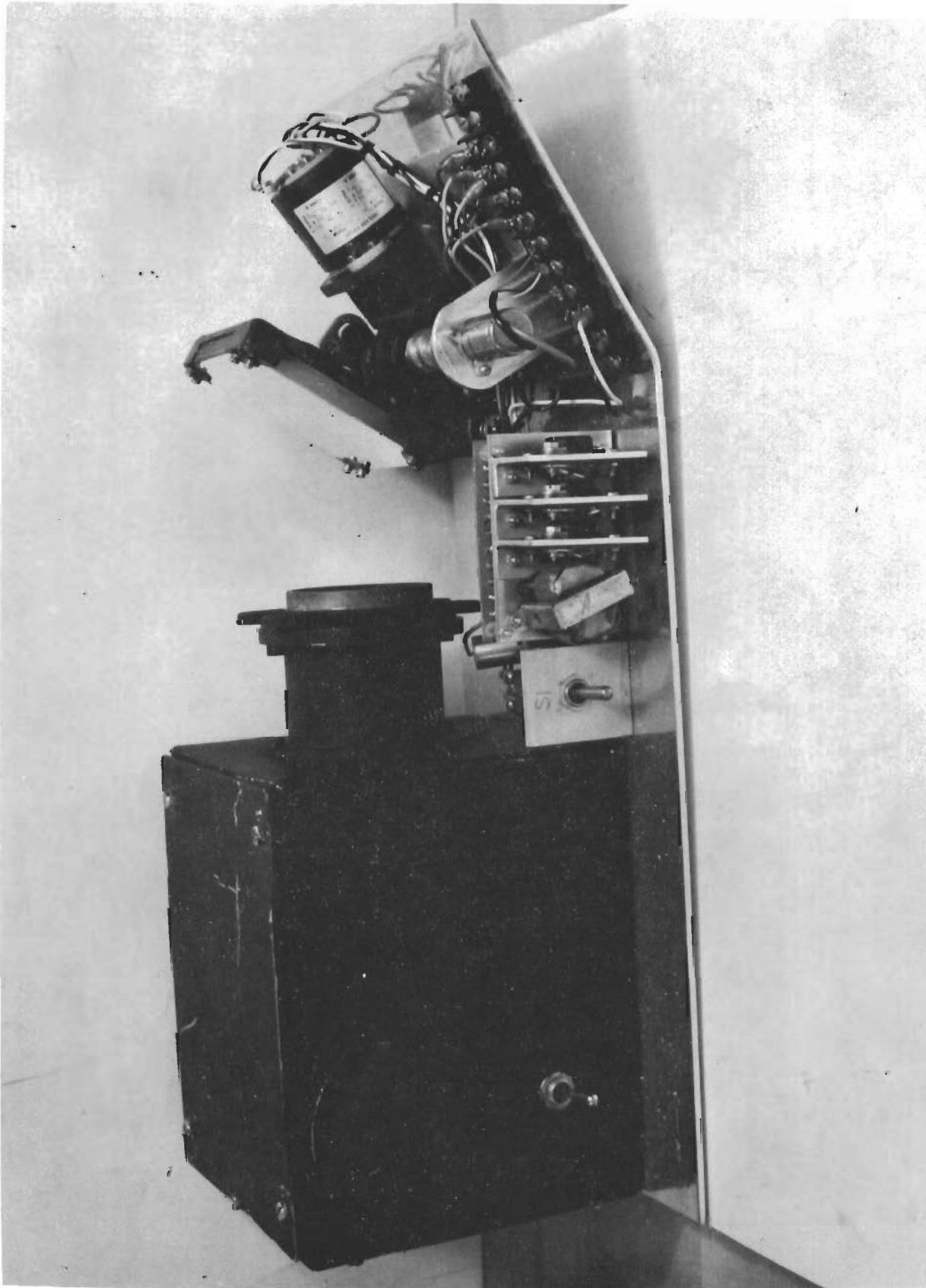

Figure 3. Side View of Projector Assembly

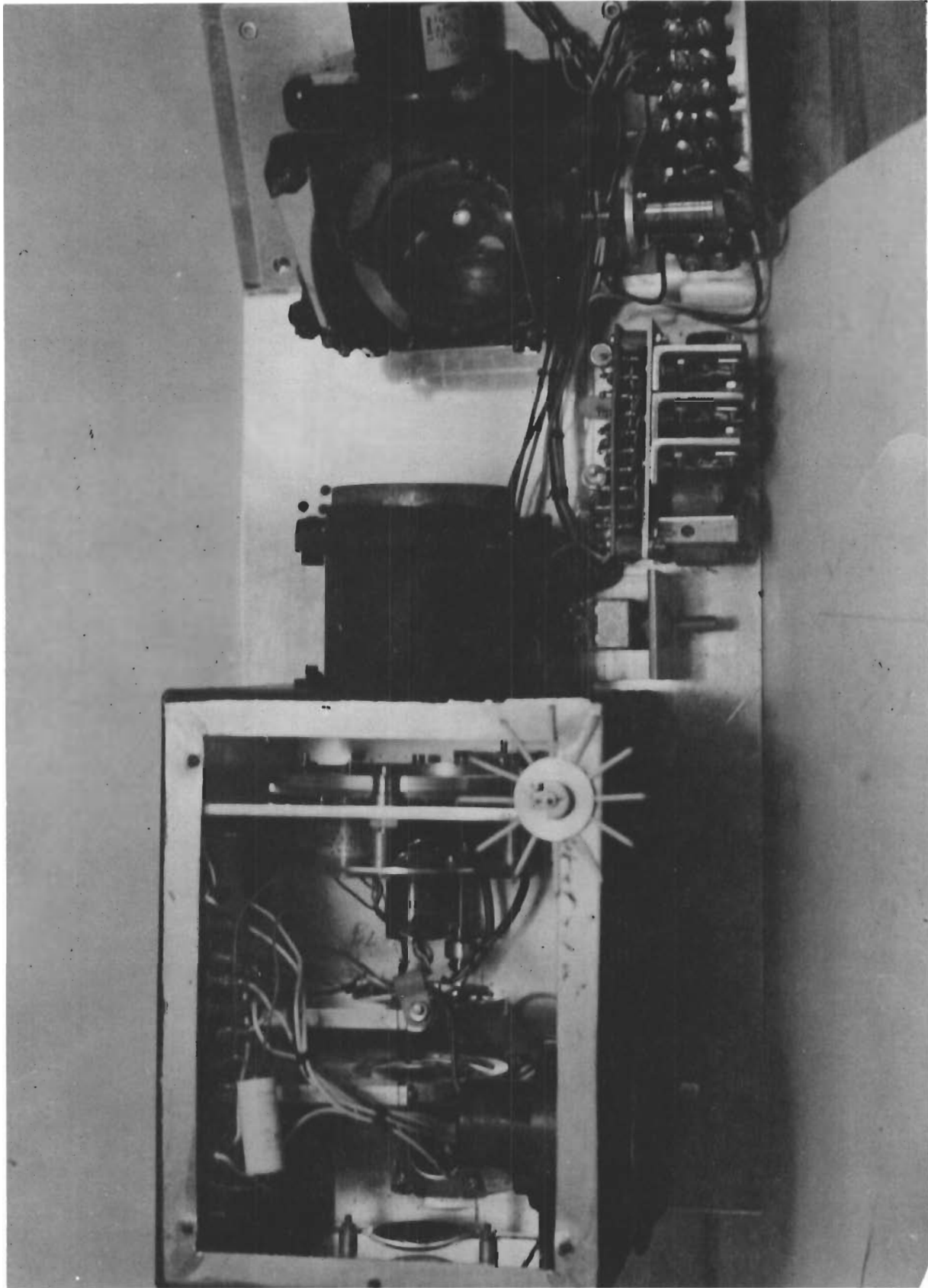

Figure 4. Top View of Projector Assembly

SECTION IV

SUMMARY AND CONCLUSIONS

SUMMARY

During instrument flight conditions, an aircraft's attitude can gradually change because the pilot's attention is diverted to operate a radio or navigation equipment. Under these conditions, the pilot, through his peripheral vision, is aware of these attitude changes even though his attention is directed away from the flight instruments. The concept of this project was to develop a prototype device which would present visual information to the pilot and make use of his peripheral vision.

Initial breadboard exploratory efforts were conducted to project a line of light across the instrument panel of a simulator. The light beam moved in the pitch and roll axis and was modulated to give the illusion of heading or yaw motion. A prototype instrument was developed which utilized a slide projection kit for the optical portion of the display. A light source was condensed into a beam and passed through a cylindrical lens. The light beam was reflected from a mirror assembly on to the instrument panel. Pitch and roll movement was accomplished by rotating the mirror assembly for the pitch axis, and rotating the cylindrical lens in the roll axis. The modulated horizontal lines were achieved by rotating a spoked wheel through the light line.

CONCLUSION

The first operational model of the Peripheral Vision Display was installed in the Universal Flight Trainer. The display operates satisfactorily and the light line is clear and bright, moves as desired, and

optical distortion is low. The display was demonstrated, on an informal basis, to approximately fifty people over a period of a few months. Based on the work conducted on the Peripheral Vision Display, and the comments received, the following conclusions were made:

1. Senior individuals in air line companies indicated that such a device is needed, and that this approach to presenting information would be a real aid to pilots.
2. The curved cowling in modern cockpit configurations no longer adequate for pilots to line up the horizon with the top of the instrument panel.
3. An artificial horizon line projected on the instrument panel reduces pilot fatigue, by reducing the quantitative instrument readings that are required.
4. Pitch and roll changes are shown immediately, even though the pilot's attention is directed away from the flight instruments.
5. A light line provides the transition from the instruments to the outside world, under contact conditions. This transition has long been lost due to the present design of cockpit windows.
6. The pitch display unit is permanently attached to the Universal Flight Simulator. On the basis of the favorable comments, the package should be redesigned and universalized so that it can be used on all simulators, or manually operated for demonstrations.

REFERENCES

1. W. Greenberg, Demodulator, 400 Cycle - General Purpose. Dayton Laboratory Tech. Memo. #3, Link Group/Systems Division, General Precision, Inc., 20 December, 1963.
2. E. D. Vinson, Transistorized Servo Amplifier. Dayton Laboratory Tech. Memo #2, Link Group/Systems Division, General Precision, Inc., 2 December, 1963.

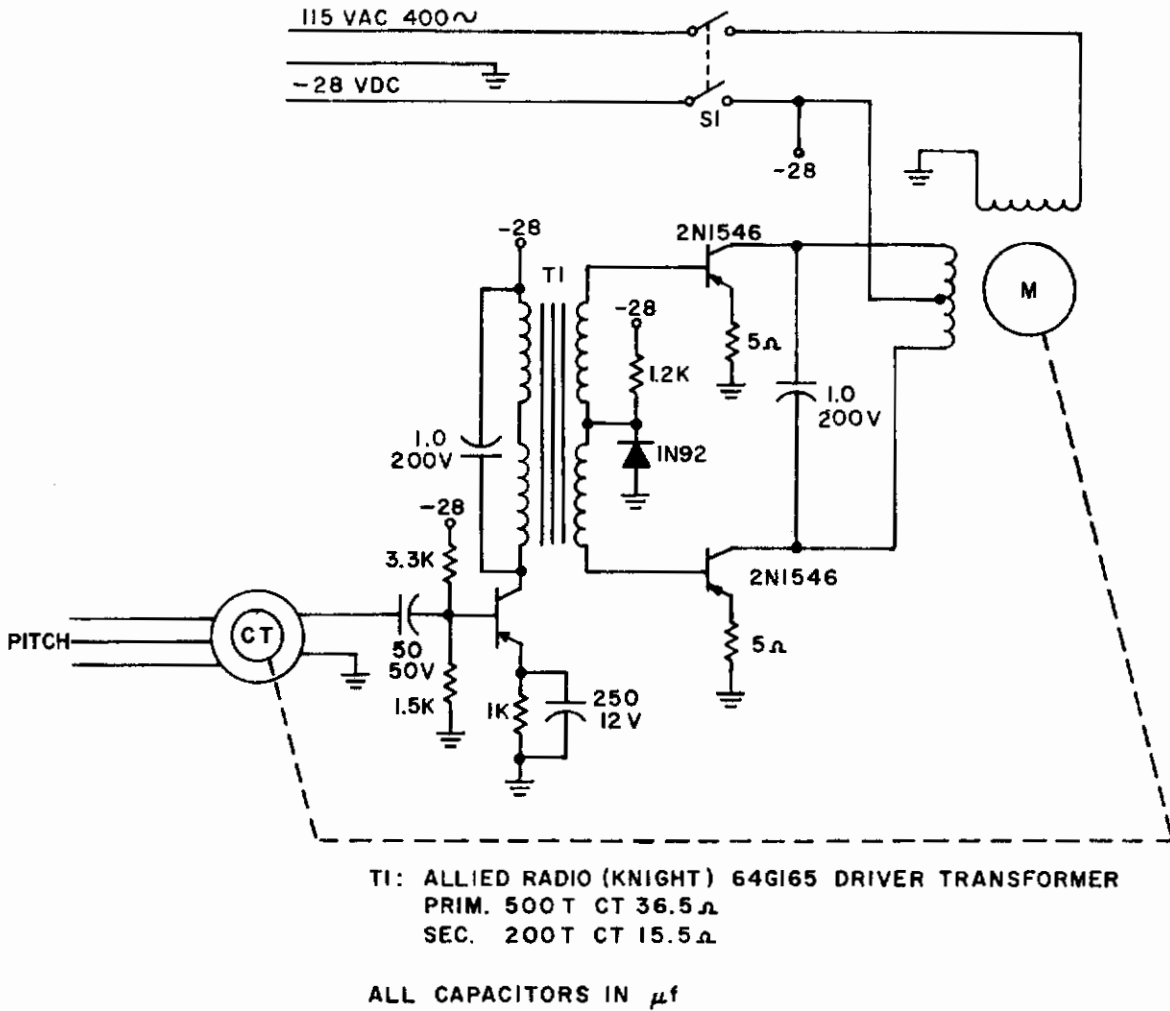

Figure 5. Pitch System Schematic

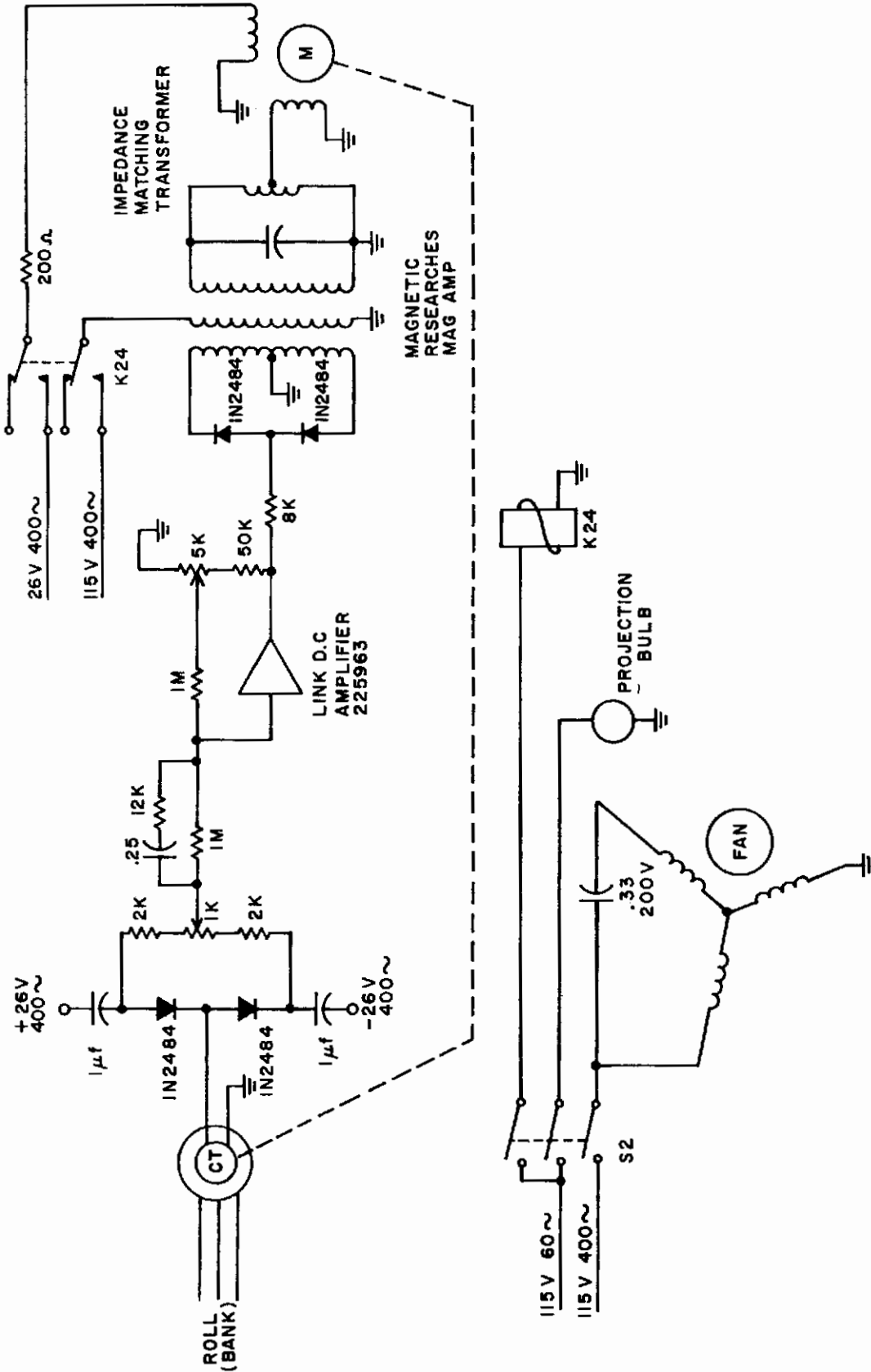

Figure 6. Roll System Schematic

UNCLASSIFIED
Security Classification

DOCUMENT CONTROL DATA - R&D		
<i>(Security classification of title, body of abstract and indexing annotation must be entered when the overall report is classified)</i>		
1. ORIGINATING ACTIVITY (Corporate author) Link Group, General Precision, Inc., Binghamton, New York		2a. REPORT SECURITY CLASSIFICATION Unclassified
		2b. GROUP
3. REPORT TITLE A PROTOTYPE PERIPHERAL VISION AIRCRAFT ATTITUDE DISPLAY		
4. DESCRIPTIVE NOTES (Type of report and inclusive dates)		
5. AUTHOR(S) (Last name, first name, initial) Williamson, William R.		
6. REPORT DATE October 1966	7a. TOTAL NO. OF PAGES 19	7b. NO. OF REFS 2
8a. CONTRACT OR GRANT NO. AF 33(615)2895	9a. ORIGINATOR'S REPORT NUMBER(S) AFFDL-TR-66-91	
b. PROJECT NO. 6190		
c. Task No. 619004	9b. OTHER REPORT NO(S) (Any other numbers that may be assigned this report) 64-132	
d.		
10. AVAILABILITY/LIMITATION NOTICES The distribution of this document is unlimited.		
11. SUPPLEMENTARY NOTES	12. SPONSORING MILITARY ACTIVITY Air Force Flight Dynamics Laboratory (FDCR) Wright-Patterson Air Force Base, Ohio 45433	
13. ABSTRACT An instrument is described for presenting attitude information to the pilot in such a manner that he may maintain an awareness of his attitude through Peripheral Vision without the necessity for looking directly at a specific instrument. The system does this by projecting a line of light on the aircraft instrument panel and moving it in a manner similar to the motion of the real horizon. A design criteria and a detailed engineering description of the working model are also presented.		

DD FORM 1473
1 JAN 64

UNCLASSIFIED
Security Classification

14.	KEY WORDS	LINK A		LINK B		LINK C	
		ROLE	WT	ROLE	WT	ROLE	WT
	Display Artificial Horizon Attitude Indicator Light Line Projection System						

INSTRUCTIONS

1. **ORIGINATING ACTIVITY:** Enter the name and address of the contractor, subcontractor, grantee, Department of Defense activity or other organization (*corporate author*) issuing the report.
- 2a. **REPORT SECURITY CLASSIFICATION:** Enter the overall security classification of the report. Indicate whether "Restricted Data" is included. Marking is to be in accordance with appropriate security regulations.
- 2b. **GROUP:** Automatic downgrading is specified in DoD Directive 5200.10 and Armed Forces Industrial Manual. Enter the group number. Also, when applicable, show that optional markings have been used for Group 3 and Group 4 as authorized.
3. **REPORT TITLE:** Enter the complete report title in all capital letters. Titles in all cases should be unclassified. If a meaningful title cannot be selected without classification, show title classification in all capitals in parenthesis immediately following the title.
4. **DESCRIPTIVE NOTES:** If appropriate, enter the type of report, e.g., interim, progress, summary, annual, or final. Give the inclusive dates when a specific reporting period is covered.
5. **AUTHOR(S):** Enter the name(s) of author(s) as shown on or in the report. Enter last name, first name, middle initial. If military, show rank and branch of service. The name of the principal author is an absolute minimum requirement.
6. **REPORT DATE:** Enter the date of the report as day, month, year, or month, year. If more than one date appears on the report, use date of publication.
- 7a. **TOTAL NUMBER OF PAGES:** The total page count should follow normal pagination procedures, i.e., enter the number of pages containing information.
- 7b. **NUMBER OF REFERENCES:** Enter the total number of references cited in the report.
- 8a. **CONTRACT OR GRANT NUMBER:** If appropriate, enter the applicable number of the contract or grant under which the report was written.
- 8b, 8c, & 8d. **PROJECT NUMBER:** Enter the appropriate military department identification, such as project number, subproject number, system numbers, task number, etc.
- 9a. **ORIGINATOR'S REPORT NUMBER(S):** Enter the official report number by which the document will be identified and controlled by the originating activity. This number must be unique to this report.
- 9b. **OTHER REPORT NUMBER(S):** If the report has been assigned any other report numbers (*either by the originator or by the sponsor*), also enter this number(s).
10. **AVAILABILITY/LIMITATION NOTICES:** Enter any limitations on further dissemination of the report, other than those

imposed by security classification, using standard statements such as:

- (1) "Qualified requesters may obtain copies of this report from DDC."
- (2) "Foreign announcement and dissemination of this report by DDC is not authorized."
- (3) "U. S. Government agencies may obtain copies of this report directly from DDC. Other qualified DDC users shall request through _____."
- (4) "U. S. military agencies may obtain copies of this report directly from DDC. Other qualified users shall request through _____."
- (5) "All distribution of this report is controlled. Qualified DDC users shall request through _____."

If the report has been furnished to the Office of Technical Services, Department of Commerce, for sale to the public, indicate this fact and enter the price, if known.

11. **SUPPLEMENTARY NOTES:** Use for additional explanatory notes.

12. **SPONSORING MILITARY ACTIVITY:** Enter the name of the departmental project office or laboratory sponsoring (*paying for*) the research and development. Include address.

13. **ABSTRACT:** Enter an abstract giving a brief and factual summary of the document indicative of the report, even though it may also appear elsewhere in the body of the technical report. If additional space is required, a continuation sheet shall be attached.

It is highly desirable that the abstract of classified reports be unclassified. Each paragraph of the abstract shall end with an indication of the military security classification of the information in the paragraph, represented as (TS), (S), (C), or (U).

There is no limitation on the length of the abstract. However, the suggested length is from 150 to 225 words.

14. **KEY WORDS:** Key words are technically meaningful terms or short phrases that characterize a report and may be used as index entries for cataloging the report. Key words must be selected so that no security classification is required. Identifiers, such as equipment model designation, trade name, military project code name, geographic location, may be used as key words but will be followed by an indication of technical context. The assignment of links, rules, and weights is optional.