

~~CONFIDENTIAL~~  
~~RESTRICTED~~  
~~SECRET~~

AFFDL-TR-73-21-Vol. VI

# STOL TACTICAL AIRCRAFT INVESTIGATION

VOLUME VI + AIR CUSHION AND GROUND MOBILITY STUDY

J. Hebert, Jr.  
H. Weber  
G. T. Draper  
C. Kerr, Jr.  
T. F. Reid

Convair Aerospace Division of  
General Dynamics Corporation

FOREWORD

The Air Cushion and Ground Mobility Study was conducted by the Convair Aerospace Division of General Dynamics Corporation under USAF Contract F33615-71-C-1754, Project 643A, "STOL Tactical Aircraft Investigation." This contract was sponsored by the Prototype Division of the Air Force Flight Dynamics Laboratory. The USAF Project Engineer was G. Oates (PT) and the Convair Aerospace Program Manager was J. Hebert. H. Weber, G. T. Draper, C. Kerr, Jr., T. F. Reed, and R. P. Alexander were the principal contributors.

The research reported was conducted during the period from 7 June 1971 through 31 January 1973. This report was submitted by the author on 31 January 1973 under contractor report number GDCA-DHG73-001.

This report has been reviewed and is approved.



E. J. CROSS, JR.  
Lt. Col. USAF  
Chief, Prototype Division

## ABSTRACT

The Tactical STOL transport design must consider forms of high flotation landing gear to operate effectively from unprepared fields. One configuration of particular interest is the Air Cushion Landing System (ACLS) which utilizes the ground effect principle to reduce ground overpressures. This system has been designed for the MST based on Air Force Flight Dynamics Laboratory development experience on model and full scale testing of the LA-4 (References 1 through 6). The configuration includes a rubber-nylon, torus-shaped trunk attached to the lower portion of the fuselage. Air is supplied to the trunk by turboshaft-driven fans. It is then exhausted through rows of holes along the trunk ground tangent. This creates a pressurized area (cushion) under the fuselage. Aircraft weight is distributed over the cushion area providing the desired low ground pressure. After liftoff, the trunk is deflated and retracts into the side of fuselage by elastic action of the trunk material. Braking is accomplished by expanding inflatable pillows against the ground and bleeding off cushion pressure. The aircraft skids on the sacrificial brake lining.

Assuming that LA-4 test data may be scaled to an aircraft of the MST size and configuration, the analysis presented in this report indicates the following MST/ACLS characteristics:

1. Ground pressures less than 2 psi.
2. Operating Weight (Empty) reduced by 1,908 pounds.
3. Obstacle negotiation ability on the order of 1.5-foot obstacle height.
4. Excellent energy absorption characteristics allowing sink rate of 15 fps with vertical load factor less than 4 g.
5. Favorable survivability, vulnerability and reliability compared to conventional gear.
6. Increased maintenance and crew workload due to addition of two turboshaft-fan sets.

7. Takeoff distance on CBR 6 runway is reduced by 425 feet if rolling friction is assumed to be zero.

The cargo delivery/loading capability of the MST can be greatly expedited by incorporating an onboard ground mobility system in conjunction with conventional landing gear. After viewing various wheel drive systems (pneumatic, electrical, hydraulic), a mechanical drive system is presented. A gas turbine APU is mounted to the shock strut over each bogie, driving the wheels through reversing gear, clutch and shafting. Sized for 5 mph on a 4-percent ( $\mu = 0.15$ ), the incremental weight is estimated to be 843 pounds.

TABLE OF CONTENTS

<u>Section</u>		<u>Page</u>
1	INTRODUCTION	xi
2	AIR CUSHION LANDING SYSTEM	2-1
	2.1 SYSTEM DESCRIPTION	2-1
	2.2 SIZING PROCEDURE	2-3
	2.3 DYNAMIC CHARACTERISTICS	2-13
	2.4 OPERATIONAL CHARACTERISTICS	2-16
3	POWERED LANDING GEAR	3-1
4	CONCLUSIONS AND RECOMMENDATIONS	4-1
5	REFERENCES	5-1

## LIST OF ILLUSTRATIONS

<u>Figure</u>		<u>Page</u>
2-1	Externally Blown Flap Configuration	2-2
2-2	Trunk Shape Parameters	2-4
2-3	ACLS Planform	2-5
2-4	Trunk Cross Section	2-7
2-5	Cushion Exhaust Pressure Distribution	2-8
2-6	ACLS Flow and Power Requirements	2-9
2-7	ACLS Weight Comparison	2-12
2-8	Horizontal Stabilizer $C_L$ Required for Takeoff Rotation vs Roll Velocity	2-14
2-9	Maximum Sink Rate vs Design $p_c/p_j$ Gross Weight = 135,000 Pounds	2-14
2-10	Maximum Sink Speed vs Gross Weight ( $p_c/p_j = 0.5$ )	2-15
2-11	Maximum Load Factor vs Sink Speed ( $p_c/p_j = 0.5$ )	2-15
2-12	ACLS Performance Comparison	2-17
3-1	Powered Landing Gear Configuration	3-5

LIST OF TABLES

<u>Table</u>		<u>Page</u>
2-1	Trunk Cross Section Dimensions	2-4
2-2	Fan/Drive System Parameters	2-11
2-3	ACLS Weight Estimate	2-12
2-4	Dimensional Similarity	2-16
2-5	Operational Advantages and Disadvantages of the ACLS Compared to CLG	2-20

## NOMENCLATURE

$A_c$	Cushion area, ft. <sup>2</sup>
$A_j$	Cross-sectional area of the trunk, ft. <sup>2</sup>
$a$	x coordinate of upper trunk attachment point, ft.
$b$	y coordinate of upper trunk attachment point, ft.
$C_D$	Coefficient of discharge for plenum chamber
$C_p$	Specific heat at constant pressure, Btu/lb. °F
$C_Q$	Flow coefficient for pressure distribution across the jets
$C_x$	Coefficient of discharge for the trunk nth row of orifices in the trunk
$d$	Jet height of trunk daylight clearance, ft.
$g$	Acceleration due to gravity, ft./sec. <sup>2</sup>
$g_o$	Constant from Newton's law, lbm - ft./lbf - sec. <sup>2</sup>
$P(p)$	Pressure, psfa (psfg)
$P_a$	Atmospheric pressure, psfa
$P_c(p_c)$	Cushion pressure, psfa (psfg)
$P_j(p_j)$	Trunk pressure, psfa (psfg)
$P_{T_2}$	Total pressure at fan face, psfa
$P_{T_3}$	Fan discharge total pressure, psfa
$p_c/p_j$	Cushion to trunk pressure ratio (both pressures in psfg)
$Q$	Flow rate, ft. <sup>3</sup> /sec.



# Contrails

$\bar{R}$	Universal gas constant, Btu/lb. °F
S	Cushion perimeter, ft.
T	Absolute temperature of air, °F
w	Mass flow of the gas, lb./sec.
$x_0$	x coordinate of minimum jet height point, ft.
$y_0$	y coordinate of minimum jet height point, ft.
	Greek letters
$\lambda_n$	Distance along the trunk from attachment point (a, b) to the nth row of orifices, ft.
$\pi$	Dimensionless ratio of trunk dimensions used in scaling
$\rho$	Density of the gas, lb./ft. <sup>3</sup>
	Subscripts
A	Aircraft
a	Atmosphere
c	Cushion
f	Fan
j	Trunk
0	Atmosphere

# *Contrails*

## SECTION 1 INTRODUCTION

Air Force interest in tactical STOL transport designs has emphasized a need to improve operations from unprepared fields. The present ground operational capability of high flotation landing gears relates directly to field conditions. For instance, a landing gear on an externally blown flap configuration designed to operate on a 2000 foot CBR 6 field would weigh 9521 pounds or approximately 10 percent of the basic operating weight (empty). Typical rolling and braking coefficients for the gear are 0.10 and 0.30, respectively.

A concept of particular interest for more effective operation from unprepared fields is the air cushion landing system (ACLS). It offers a potential reduction in gear weight and rolling coefficient that could result in a smaller aircraft operating at lower STOL gross weights. STOL operations could also be accomplished on unprepared CBR fields of less than 6.

Design of the ACLS for a STOL tactical aircraft was performed on the following basis:

1. Information presented in Air Force Flight Dynamics Laboratory reports (References 1 through 6) was used as a design basis for system sizing and performance analysis.
2. The ACLS was designed into the externally blown flap aircraft configuration, thus representing a typical MST design.
3. Complete redundancy was required of the ACLS air supply system so that one turboshaft-fan unit would provide acceptable smooth runway landing performance. A single unit was sized to provide that performance at contingency power at 2500-foot altitude on a 93.4° F day (MIL-STD-210A hot day). The additional power available under normal operation would be used for unprepared field conditions.

The requirement for an onboard ground mobility system in conjunction with a high flotation gear was investigated very briefly. Several systems were considered for driving the aircraft at five mph on a four percent grade.

# *Contrails*

## SECTION 2

### AIR CUSHION LANDING SYSTEM

#### 2.1 SYSTEM DESCRIPTION

The ACLS system is designed into an externally blown flap version of the MST, shown in Figure 2-1. The ACLS trunk is sixty feet long and attached to the lower fuselage from the aft loading door forward. The trunk is a rounded rectangle in planform with a 16-foot width between ground tangent lines. Two scaled T58 turboshaft engines, reduction gear, and fans are installed above the cargo compartment aft of the wing spar. Fan discharge is ducted to the trunks down both sides of the interior fuselage. Flow channels, formed by skinning over three spans between stringers, do not restrict walkway access. Engines and fans draw ambient air from the top of the fuselage through flush inlets which are closed off by remotely operated doors when not in use. The engine exhausts are flush with fuselage exterior and are directed sideways and aft to clear aircraft control surfaces.

The trunk includes provisions for attachment, parking bladder, brake pillows and tread similar to the configurations described in Air Force Flight Dynamics Laboratory reports.

The installation of the ACLS was governed by the following design constraints:

1. Except for the trunk, all elements of the ACLS to be installed within the airframe contour and outside the cargo bay envelope.
2. Maintain safety aisle.
3. High engine and fan inlets — propulsion engine inlet same level or higher.
4. Adequate access to engine and fans.
5. Overturn angle 63° maximum.
6. Minimum vulnerability

Figure 2-1 represents a design which is in accordance with the above constraints. The maximum overturn angle is 63 degrees based on the 16-foot tread and the maximum vertical cg. The selected location of the fans and fan engines resulted

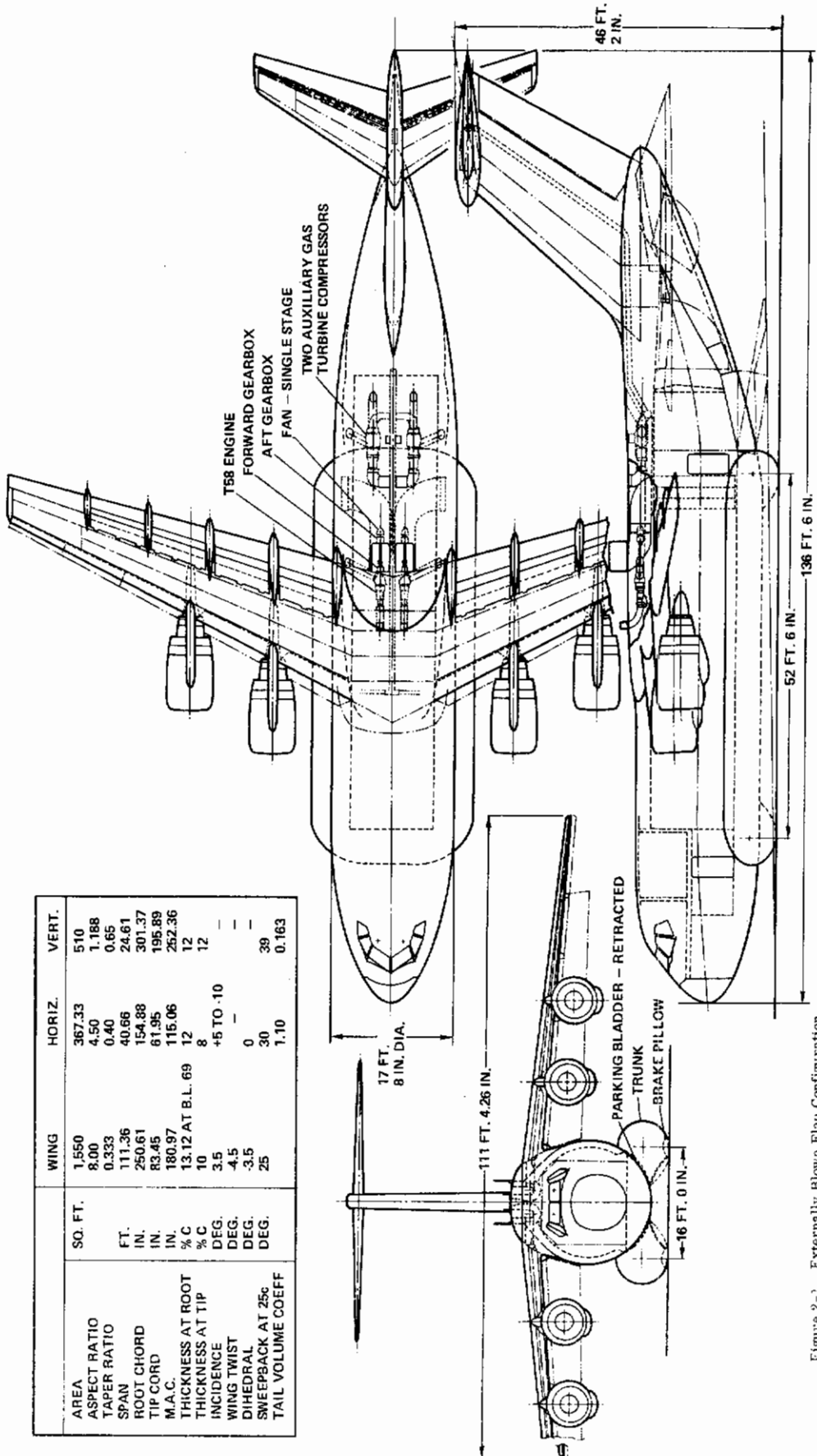

Figure 2-1. Externally Blown Flap Configuration

in the least weight and performance penalty. Weight considerations pertain to maintaining a circular fuselage to efficiently react internal pressure loads. Modifying the circular fuselage shape or depressurizing compartments adds weight. If the entire underfloor is depressurized the weight penalty is greater than depressurizing above the cargo box envelope. The difference is due to the weight load carried by the floor in addition to the pressure load. Therefore, the underfloor area is pressurized and the area above the cargo envelope local to the fan-engine installation is unpressurized. Another basic airframe constraint is the narrow passage between the lower corner of the cargo envelope and the fuselage contour. Any duct traversing this area is forced to a rectangular shape and occupies the space between frames.

Aside from weight penalties, an alternative extreme aft underfloor installation is also feasible. In this installation, fan outlet air ducts directly into the trunk and the engine exhaust ducts aft and out through the ramp. The entire underfloor area serves as fan and engine inlet requiring minimal ducting. The intake opening is located just aft of the radome. Since the entire area is pressurized, all fan and fan engine inlets and the forward intakes require pressure seal doors which have to be time sequenced with the fuselage pressurization. The underfloor engine-fan access is through the cargo floor since the trunk restricts all external access. The underfloor installations, especially mounted at the aft end of the cargo bay, are more vulnerable than the overhead installations.

## 2.2 SIZING PROCEDURE

Using the 1/3 scale C119 ACLS model, Table 4-1 of Reference 1, as a base, trunk size parameters scale as follows:

$$\text{At constant Froude No. } \left( \frac{v}{\sqrt{ql}} \right) \quad l \sim \sqrt[3]{W}$$

then:

$$\lambda = \sqrt[3]{\frac{GW_{MST}}{GW_{C119}}} \left[ \frac{l_{C119}}{l_{model}} \right] = \sqrt[3]{\frac{167,762}{60,000}} [3] = 4.3$$

Resulting parameters of trunk length, attachment point coordinates, and scale factors are listed in Table 2-1. These values were used as inputs to the computer program EQUI (Appendix II, Reference 1) to generate the remaining geometrical dimensions required to determine trunk cross-section, Figure 2-2.

Table 2-1. Trunk Cross Section Dimensions

PARAMETER	END TRUNK (ft.)		SIDE TRUNK (ft.)	
	MODEL	FULL SCALE	MODEL	FULL SCALE
	2.350	10.100	1.440	6.180
b	0.000	0.000	1.000	4.300
$l$	3.100	13.300	4.620	19.800
$\pi_1$	0.880	0.880	0.382	0.382
$\pi_2$	0.000	0.000	0.570	0.570
$\sqrt{a^2 + b^2}$	2.350	10.100	1.755	7.550

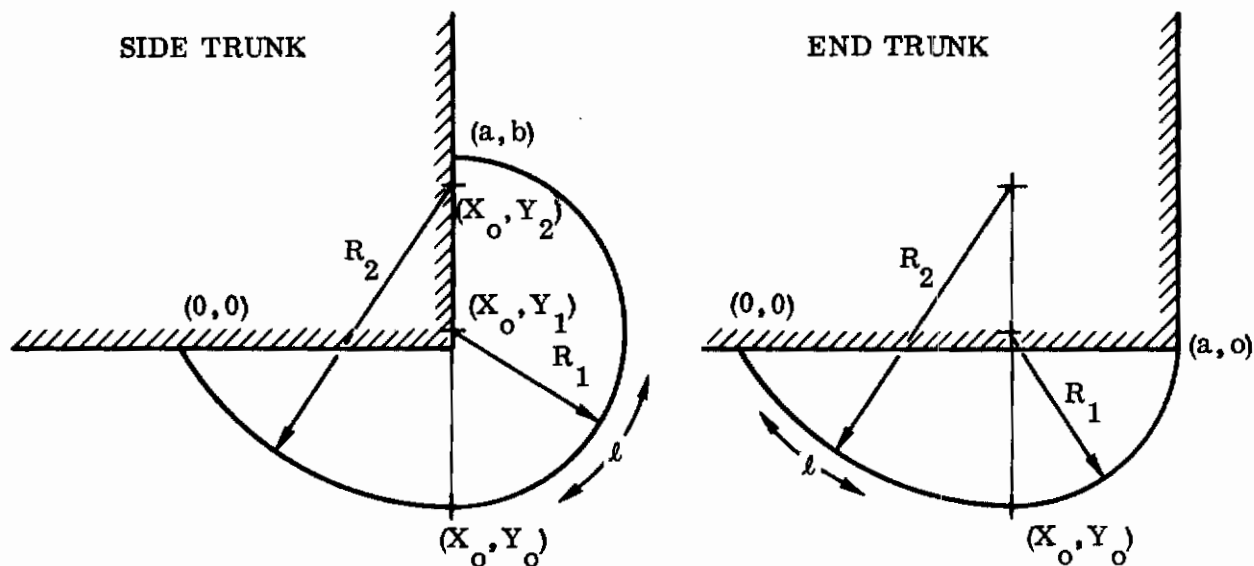

Figure 2-2. Trunk Shape Parameters

After fitting the trunk cross-section to the aircraft fuselage, the trunk planform, see Figure 2-3, is established to maximize cushion area within the attachment space available.

The trunk geometry and ambient operating conditions were used as inputs to the computer program PLMD to calculate daylight clearance flow and horsepower



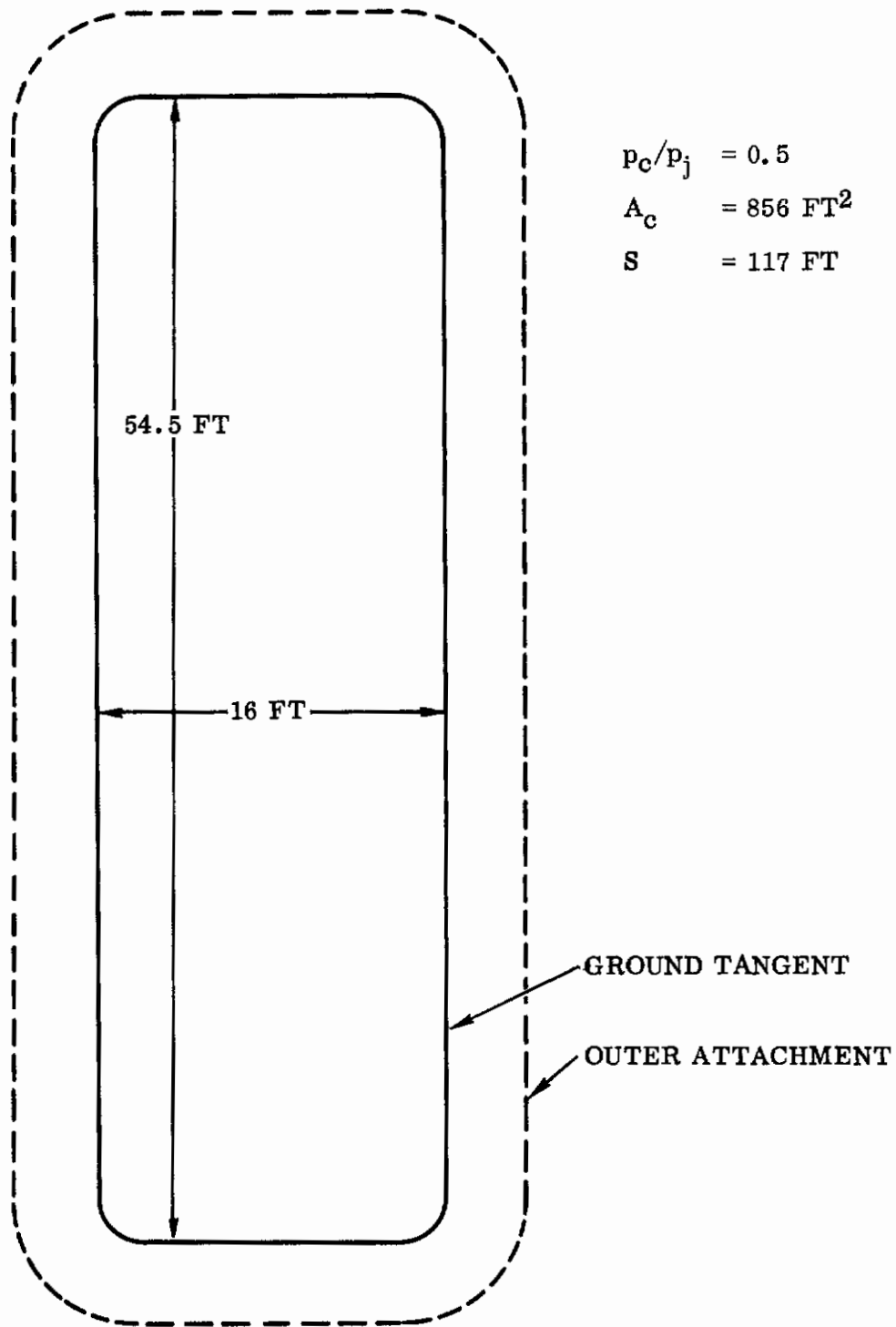

Figure 2-3. ACLS Platform

characteristics. The total effective jet thickness ( $t$ ) was adjusted to attain day-light clearance ( $d$ ) equal to that used on the LA-4 aircraft, (.25 in.) Reference 2. Two cases of cushion pressure ratio,  $p_c/p_j = 0.5$  and  $0.8$ , were evaluated representing the "hard" bag and "soft" bag conditions respectively, shown in Figure 2-4. The resulting cushion exhaust pressure distribution (see Figure 2-5) and flow/power requirements (see Figure 2-6) are presented for three gross weight conditions of the aircraft:

Maximum gross weight 167,762 lb.,  $p_c = 196$  psfg

Design gross weight 148,192 lb.,  $p_c = 173$  psfg

STOL gross weight 134,200 lb.,  $p_c = 157$  psfg

Minimum flying gross weight 120,200 lb.,  $p_c = 141$  psfg

2.2.1 Fan and Drive System Sizing — At overload gross weight, 2,500-ft. altitude, 93° F day, for  $p_c/p_j = 0.5$ :

$$HP_j = 1,060 \text{ HP}$$

$$Q_j = 1,485 \text{ cfs}$$

$$p_j = 392 \text{ psfg}$$

$$P_a = 1,932 \text{ psfa}$$

Assuming a fan inlet recovery of 0.997, total pressure at the fan face ( $P_{T2}$ ) equals 1,926 psfa. With an assumed fan exit Mach number of 0.3 and a loss of one dynamic head in delivery to the trunk, fan discharge total pressure ( $P_{T3}$ ) equals:

$$P_{T3} = \frac{P_j}{(0.941)} = 2,470 \text{ psfa}$$

$$\text{Fan pressure ratio } (r_F) = \frac{P_{T3}}{P_{T2}} = \frac{2,470}{1,926} = 1.285$$

With a fan efficiency,  $(\eta_F) = 0.85$ :

$$\Delta T_F = T_1 \frac{\frac{\gamma-1}{\gamma} (r_F^\gamma - 1)}{\eta_F} = 48.3^\circ \text{ F}$$

## INELASTIC TRUNK SHAPES

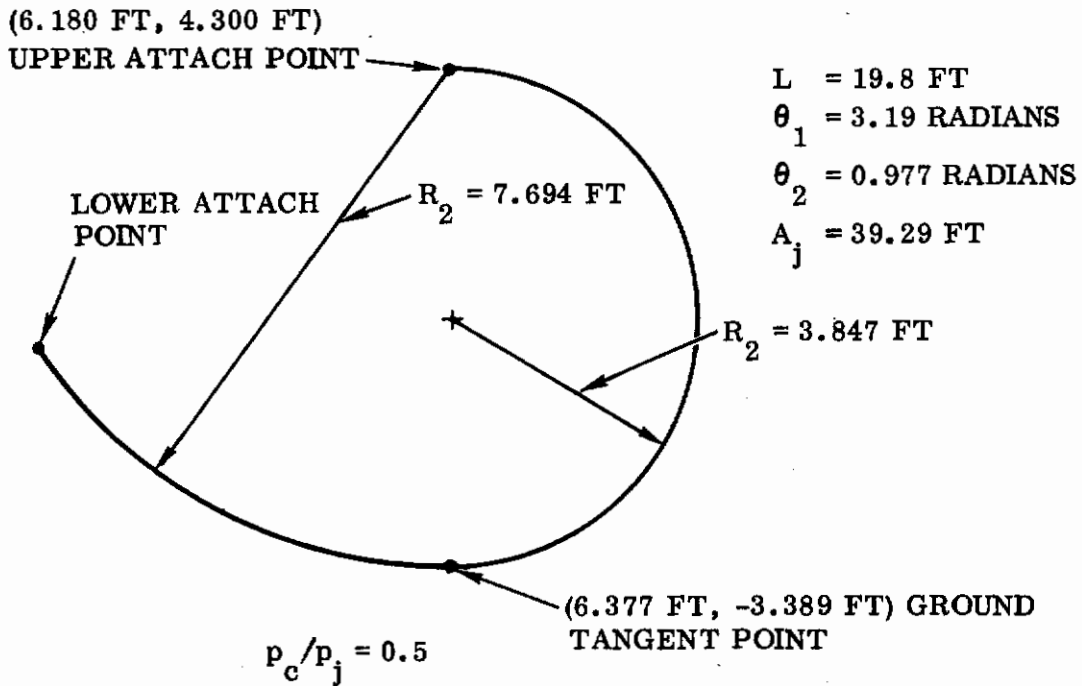
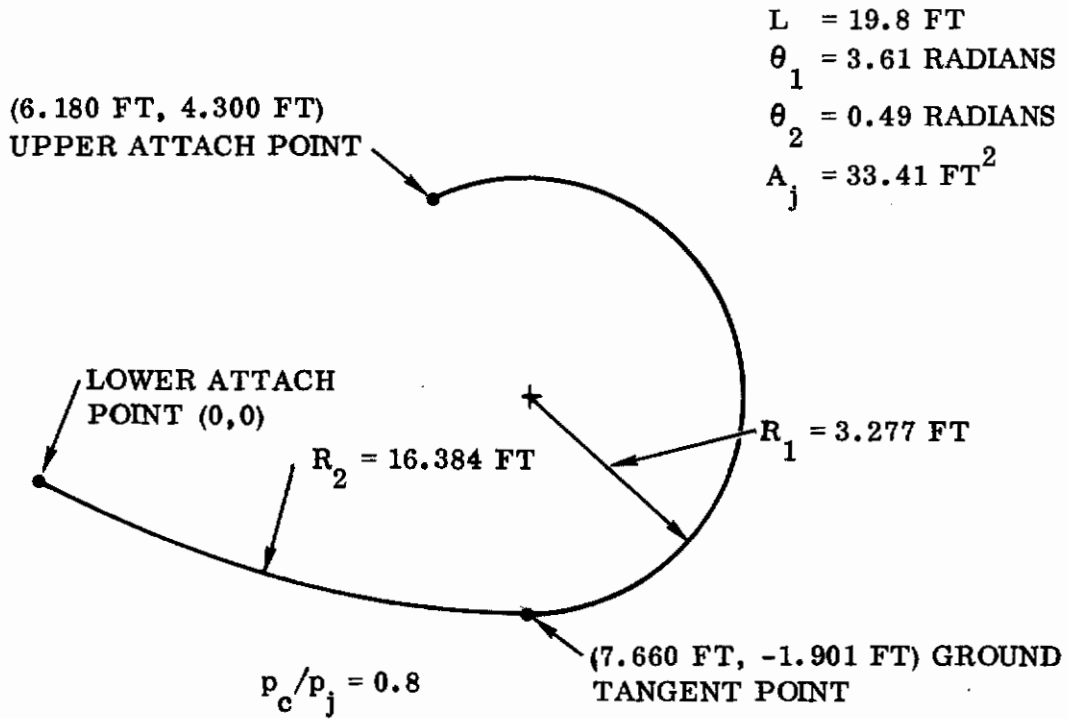

Figure 2-4. Trunk Cross Section

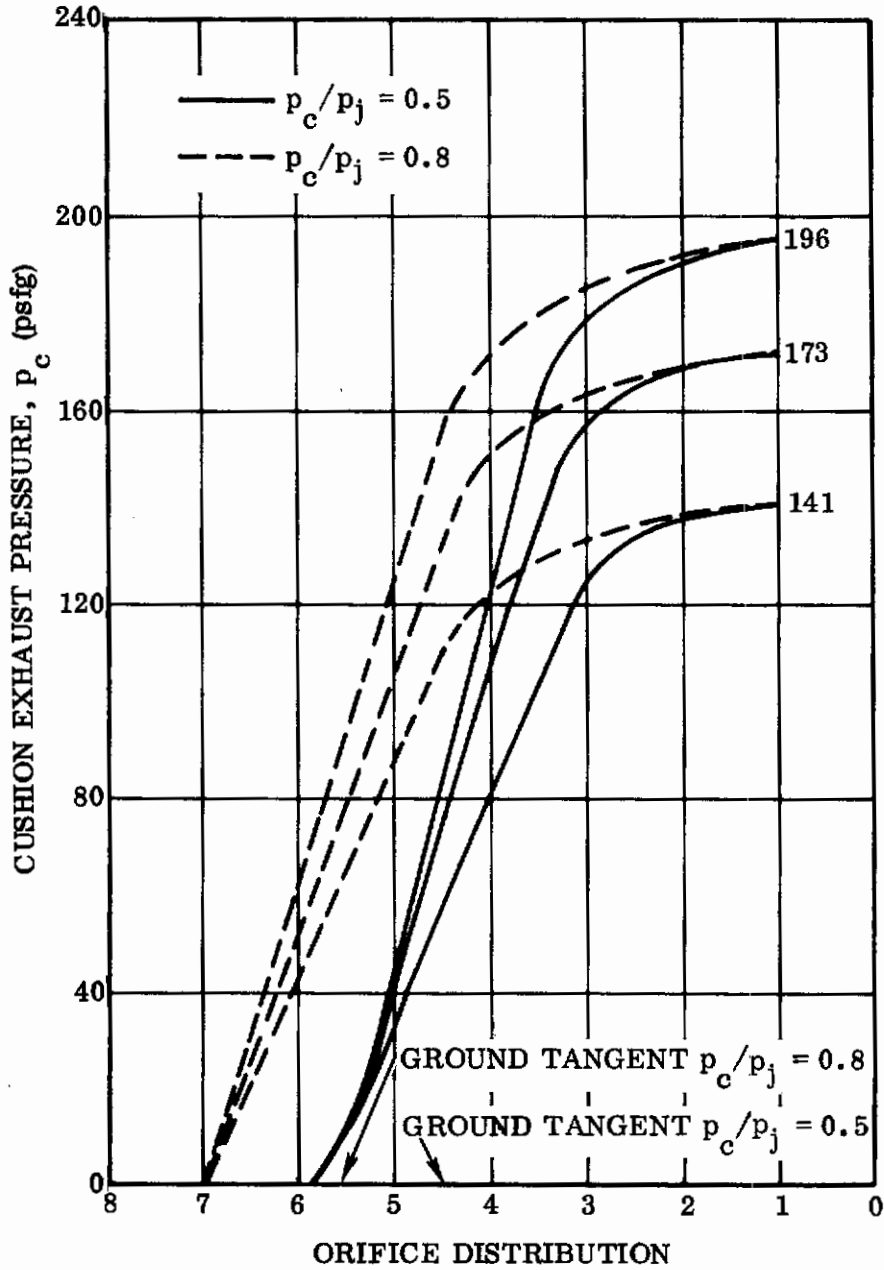

Figure 2-5. Cushion Exhaust Pressure Distribution

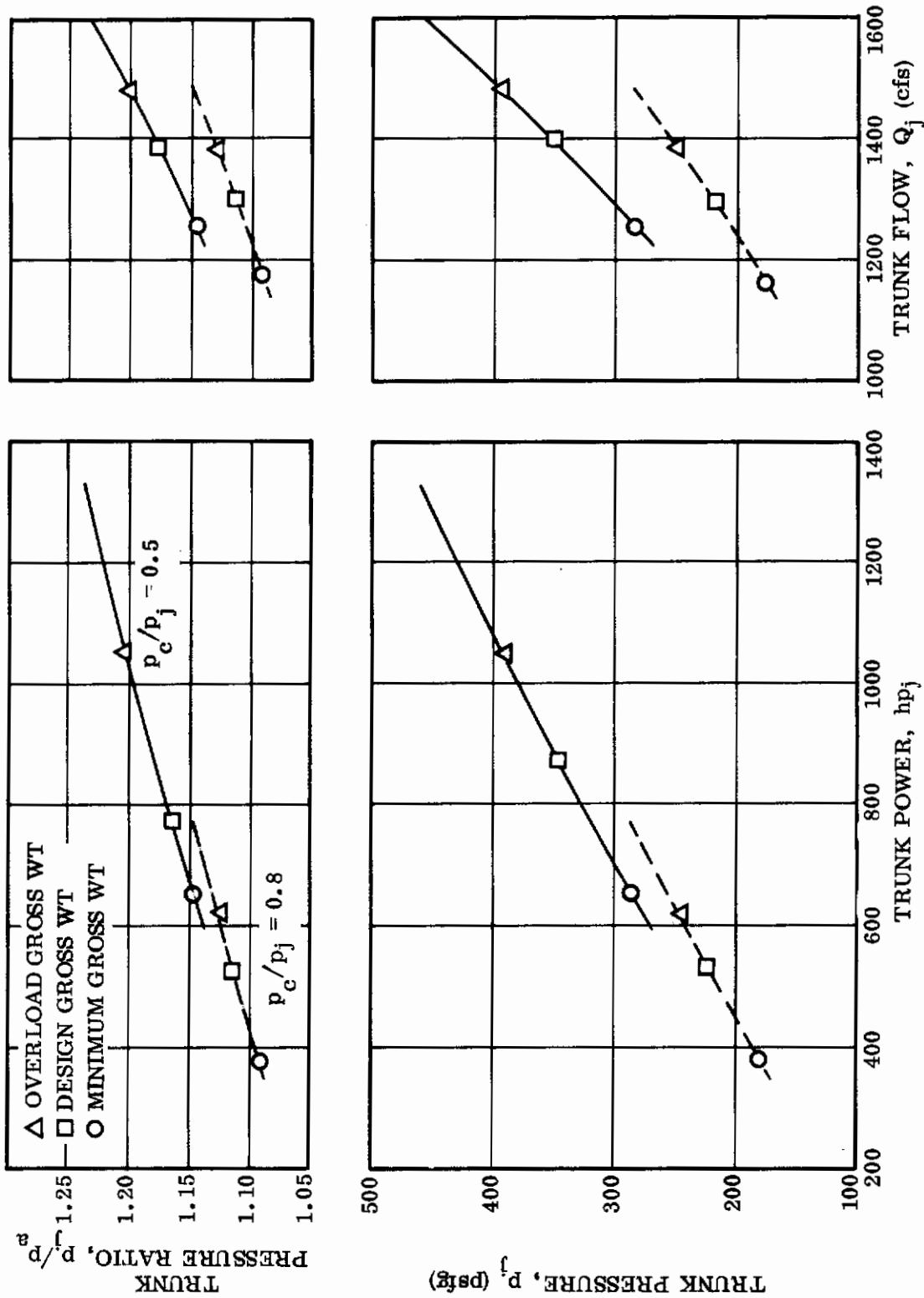

Figure 2-6. ACLS Flow and Power Requirements

# Contrails

With 2% transmission loss, drive power required ( $HP_F$ ) is:

$$HP_F = \frac{\rho Q_1 c_p (\Delta T_F)}{0.98 (0.707)} = 1635 \text{ HP}$$

$$\eta_{\text{cycle}} = \frac{HP_1}{HP_F} = 65\%$$

Assume high hub/tip ratio, lightly loaded, flat, impulse type blading

Two-stage axial flow fan

Hub/tip ratio = 0.6

$V_A = 360 \text{ fps}$

$\psi_{\text{root}} = 0.8.$

$$\text{Annulus area} = \frac{Q}{V} = \frac{1.485 \text{ cfs}}{360 \text{ fps}} = 4.13 \text{ sq. ft.}$$

Tip Diameter = 2.88 ft.

Hub Diameter = 1.72 ft.

$$\text{Pressure rise per stage} = \frac{P_{T3} - P_{T2}}{2} = 272 \text{ psfg}$$

$$\text{Since } \psi_{\text{root}} = \frac{\Delta P}{1/2 \rho U_R^2}, \quad U_R = 538 \text{ fps, and } U_T = 895 \text{ fps}$$

$$N_F = \frac{60 U_T}{\pi D_T} = 5,920 \text{ rpm}$$

In summary, the fan absorbs 1,635 HP at 5,920 rpm at 2,500 ft., 93° F day condition. A T58-S3C turboshaft engine provides 1,580 HP (10-minute rating) under those ambient conditions at 19,500 RPM output speed.

$$\text{Engine scale factor} = \frac{1,635 \text{ HP}}{1,580 \text{ HP}} = 1.04$$

$$\text{Reduction gear ratio} = \frac{19,500 \text{ RPM}}{5,920 \text{ RPM}} = 3.3$$

A similar calculation was performed for the 0.8 cushion pressure ratio case. The results are summarized in Table 2-2.

Table 2-2. Fan/Drive System Parameters (Maximum Gross Weight Conditions)

DESIGN PARAMETER	$p_c/p_j = 0.5$	$p_c/p_j = 0.8$
Cushion Pressure ( $p_c$ ), psfg	196	196
Trunk Flow ( $Q_j$ ), cfs	1,485	1,375
Trunk Power ( $HP_j$ ), HP	1,060	615
Trunk Pressure ( $p_j$ ), psfg	392	245
Fan Pressure Ratio ( $r_F$ )	1.285	1.20
Fan Tip Diameter ( $D_T$ ), ft.	2.88	2.78
Fan Speed ( $N_F$ ), RPM	5,920	5,260
Fan Stages	2	2
Fan Drive Power ( $HP_{FD}$ ), HP	1,635	1,125
System Efficiency ( $\eta_S$ ), %	65	55
Turboshaft Engine Rating Req'd. (S.L., Static, Std. Day 10-Min. Rating)	2,000	1,375
Engine Scale Factor (Compared to T58-S3C at 1,925 HP)	1.04	0.72

Estimated weight of the ACLS system is 7,613 pounds (see Table 2-3), which is 4.53 percent of aircraft maximum gross weight. This value falls within the range of 3.5 to 5.0 percent predicted in Figure 2-7. The weight estimate is based on scaling of engine model specification data and scaling of trunk related items from Reference 3 data. Fuel capacity includes one hour of operation at half power on both engines.

Weight of the alternative high flotation landing gear, associated hardware and installation penalties is estimated to be 9,521 pounds, also shown in Table 2-3.

Table 2-3. ACLS Weight Estimate

AIR CUSHION LANDING SYSTEM (lb.)	
Engine Installation	1,179
Fuel System (1-Hr. Fuel Allowance)	897
Fan Installation	960
Trunk Installation	3,812
Fuselage Installation Penalties	<u>765</u>
	7,613
HIGH FLOTATION LANDING GEAR	
Landing Gear	7,108
Doors and Installation Penalties	<u>2,413</u>
	9,521

The application of an ACLS system to the baseline configuration as shown in Figure 2-1 would reduce the operating weight (empty) by 1,908 pounds.

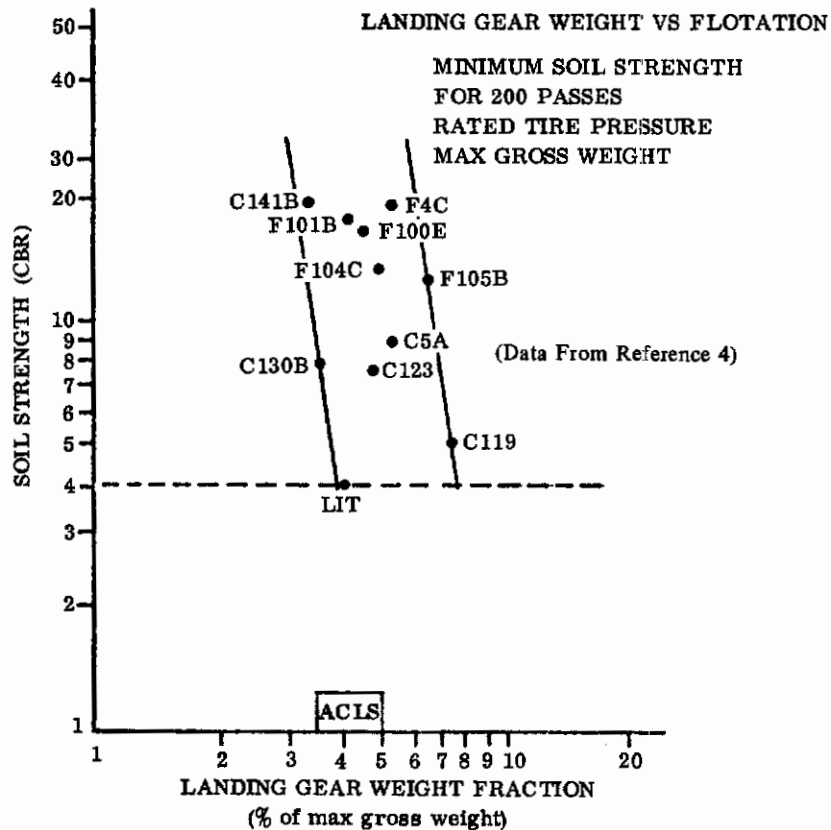

Figure 2-7. ACLS Weight Comparison



2.2.2 Ejector Air Supply System — An alternative means of providing air to the ACLS trunk is an ejector system driven by bleed air from RB 176 air blowing engines. This approach offers the following advantages compared to the turbo-shaft driven fan system:

1. Elimination of reduction gear and fan.
2. Less sensitivity to flow reversal on hard landings.

Preliminary sizing of the ejector system is based on experimental data presented in Reference 7. Assuming an augmentation ratio of 1.45 at an area ratio of 60 from referenced report, then the

Ejector discharge area	= 7.55 sq. ft.
Ejector supply jet area	= 0.13 sq. ft.
Ejector discharge Mach No.	= 0.17
Ejector supply flow	= 13 pps

The ejector provides design point flow of 1,485 cfs at  $p_c/p_j = 0.5$  and assumes a loss of one dynamic head between ejector discharge and trunk plenum. Air supply flow could be generated by oversizing the present blowing engines used for EBF.

## 2.3 DYNAMIC CHARACTERISTICS

2.3.1 Takeoff Analysis — The horizontal stabilizer  $C_L$  required to obtain liftoff attitude is a function of roll velocity (see Figure 2-8). The conditions listed on the figure are the design criterion of clearing a 50-foot obstacle at 2,000 feet at an altitude of 2,500 feet on a 93.4°F hot day. It can be seen from this figure that full rotation can be achieved prior to obtaining liftoff velocity using the blown stabilizer minimum,  $C_L = -3.15$ . Assuming that both aerodynamic and ground friction drag will be comparable to drag on conventional gear, the distance to liftoff and to 50-foot altitude will be identical for the air cushion and conventional gear. Assuming zero ground friction drag for the ACLS would reduce the distance by 425 feet.

2.3.2 Landing Analysis — Zero pitch maximum sink speeds were computed for a gross weight of 135,000 pounds and for several values of design  $p_c/p_j$ . These are shown in Figure 2-9. Values are shown for fuselage-ground contact and for a maximum air cushion deflection leaving 14 inches of clearance between the fuselage and the ground. The latter condition was selected to illustrate that expected maximum sink speeds can be tolerated with considerable fuselage-ground clearance. Maximum sink speeds as a function of gross weight are illustrated in Figure 2-10 for a  $p_c/p_j$  of 0.5. Maximum vertical load factor as a function of sink speed is illustrated in Figure 2-11.

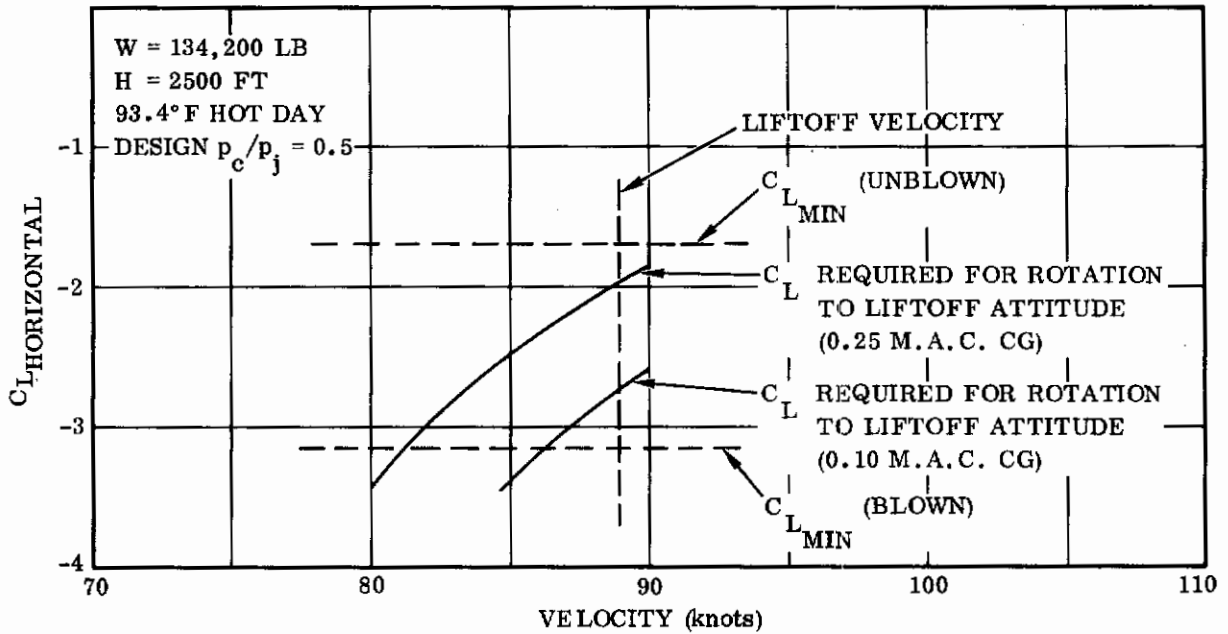

Figure 2-8. Horizontal Stabilizer  $C_L$  Required for Takeoff Rotation vs Roll Velocity

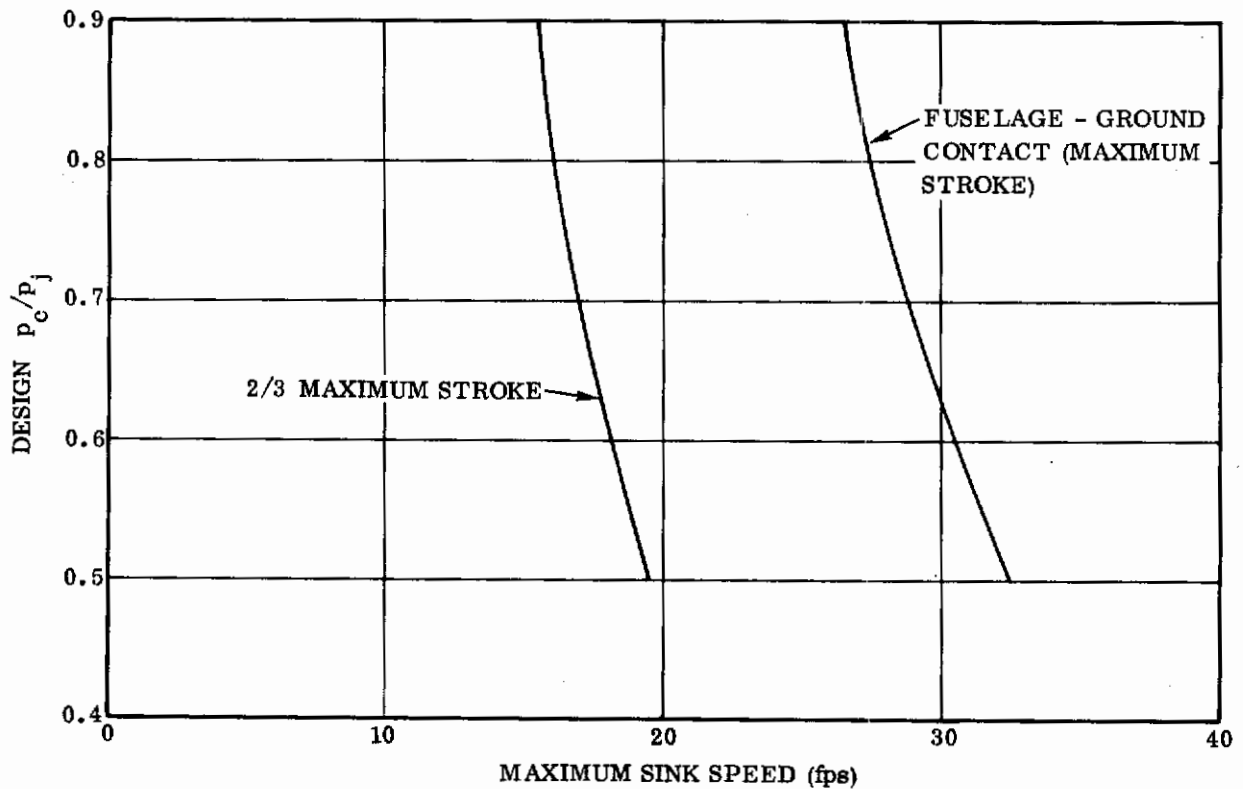

Figure 2-9. Maximum Sink Rate vs Design  $p_c/p_j$   
Gross Weight = 135,000 Pounds

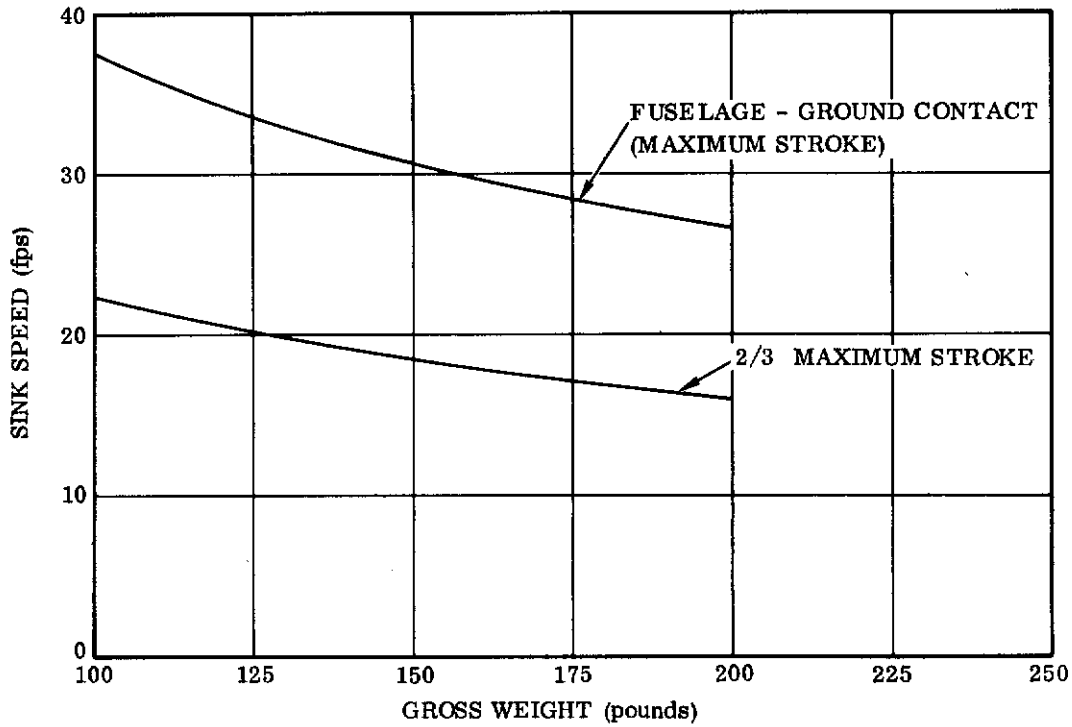

Figure 2-10. Maximum Sink Speed vs Gross Weight ( $p_c/p_j = 0.5$ )

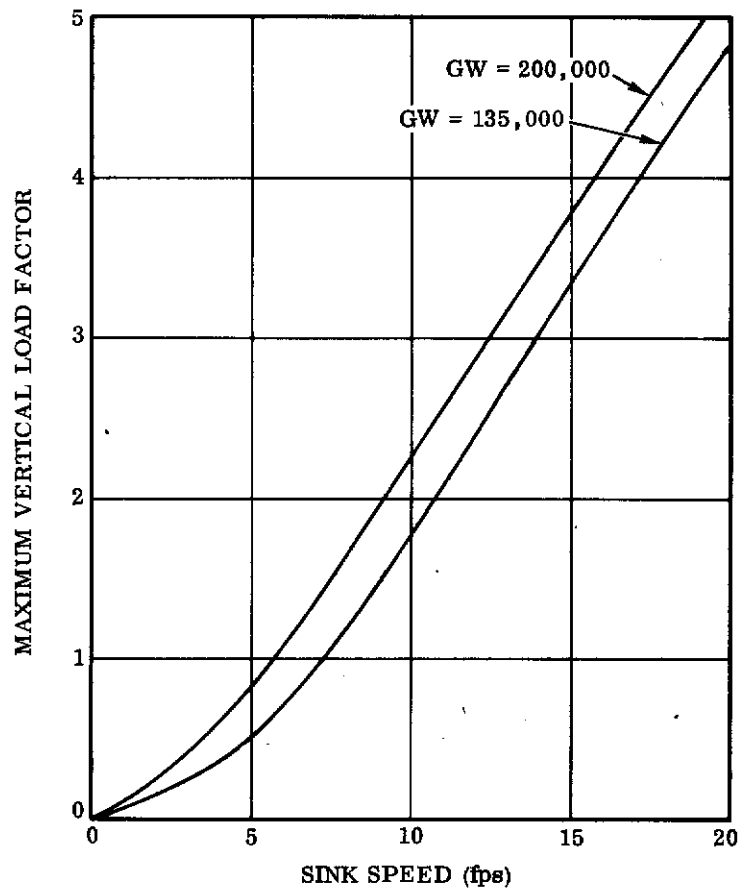

Figure 2-11. Maximum Load Factor vs Sink Speed ( $p_c/p_j = 0.5$ )

## 2.4 OPERATIONAL CHARACTERISTICS

The ACLS design exhibits low ground overpressure. Whereas high flotation gear ground pressure is in the order of 60 psi, the corresponding ACLS configuration values are:

<u>Ground Overpressure</u>	<u>Aircraft Gross Weight</u>
1.4 psi	Overload, 167,762 pounds
1.2 psi	Design, 148,198 pounds
1.0 psi	Minimum Flight Weight, 120,200 pounds

Additionally, the ACLS should be capable of operation on fields with a CBR of 1 compared to 4 for high flotation gear.

The maximum obstacle negotiation ability is reported to be half the trunk depth. At this ratio, the hard-bag design should negotiate obstacles approximately 1.5 feet high and the soft-bag design at 1.0 foot high.

The ACLS system has been designed for operation on smooth runways with one fan supply unit inoperative at 2,500 foot, 93.4-degree day conditions. Under normal operation with full power available, the MST terrain performance may be scaled from LA-4 experience using dimensional similarity, see Table 2-4.

Table 2-4. Dimensional Similarity

	LA-4	MST ( $p_c/p_j = 0.5$ )	MST ( $p_c/p_j = 0.8$ )
Gross Weight, (lb.)	2,400	167,762	167,762
$\lambda$	1.0	4.12	4.12
Scaled Power ( $\lambda^{2.5}$ )	68	2,130	2,130
Fan Power Available (HP)	68	3,270	2,250
Power Available/ Scaled Power	1.0	1.55	1.05

Assuming that terrain performance over transverse furrows is related to the ratio of available to scaled power, the MST should cross much higher leakage terrain than the LA-4. A comparison of MST/ACLS characteristics to historical aircraft designs (Reference 1) indicates general agreement with the estimated correlation (Figure 2-12).

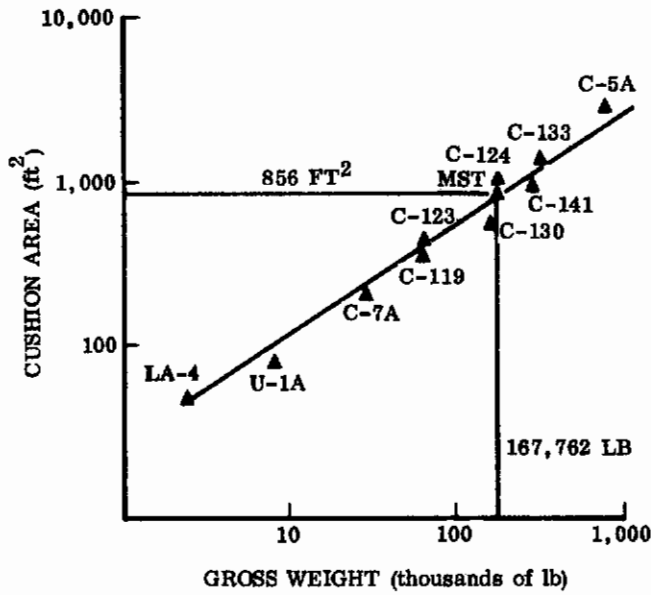

FUSELAGE AREA VS A/C GROSS WEIGHT

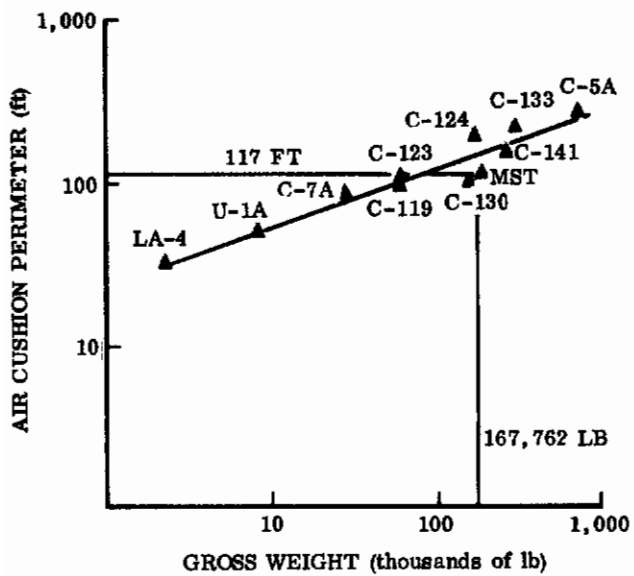

FUSELAGE PERIMETER VS A/C GROSS WEIGHT

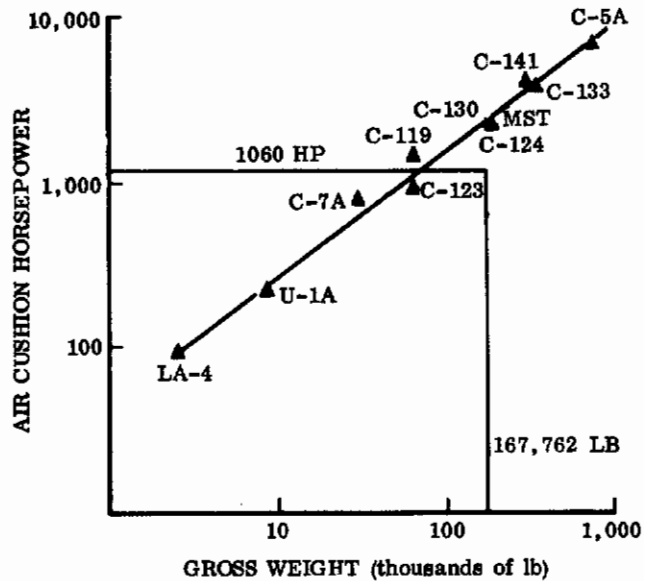

A C L S POWER VS A/C WEIGHT

Figure 2-12. ACLS Performance Comparison

2.4.1 Survivability/Vulnerability — Most of the battle damage to transport airplanes occurs on the approach, in the departure, and during ground operations. This is because the aircraft with conventional gear (CLG) has predictable approach and departure paths and landing/takeoff roll tracks on the runway. These factors, coupled with the low speeds used in these flight phases sets up ideal gunnery ranges for an enemy force and invites situations where airplane attrition rates can become high, i.e., the 1968 Khe Sanh siege in Vietnam. In this operation, air landings by airplanes (C-130, C-123) had to be abandoned in favor of aerial delivery and helicopter support due to the intensity of enemy fire and losses of transport airplanes.

The ACLS, not being confined to operating in conjunction with fixed runways, should fare much better because crews can vary their selection of approach, departure and ground paths. A vulnerability comparison of gear should also favor the ACLS because of its ability to accept bullet or fragment punctures of the trunk up to three to four square feet in area without degrading the air cushion effect. These are the most important aspects of survivability for STOL transport airplane.

Other (minor) aspects involve the possibility of a slightly lower cruise and dash speed because of increased structural drag and the vulnerability of the ACLS air ducting system. This is discussed in more detail later.

2.4.2 Maintainability — The maintainability of the ACLS itself should compare favorably with CLG because wheels, tires and brakes are a troublesome, time consuming, and costly system when life cycle costs are considered. On the surface, the system maintenance aspects of the two additional air supply engines appear to overpower other considerations but the finite answers to this problem must await more detailed study.

2.4.3 Reliability — The system reliability of the ACLS promises to be high because of inherent simplicity and complete redundancy with the dual (air supply) engines. In the unlikely event of the failure of both engines, a landing could be made on the parking bladder using a conventional foamed runway with only minor damage expected.

2.4.4 Crew Workload — The crew would have an additional workload involving starting, shutdown, status and fuel supply of two additional engines. The procedures for activating and deactivating the ACLS and for inflation/deflation of the parking bladder would be more extensive and complicated than for CLG.

2.4.5 Ground Mobility — The ACLS system does not meet the USAF desire to have ground mobility without use of the main engines since the flap blowing air supply

engines could provide only about 7,000 pounds of thrust and no steering would be available. However, with the ACLS activated the aircraft would be quite easy to tow or push. This in turn, would require ground personnel with special skills or a member of the aircrew. Moving the ACLS aircraft around the ramp or to and from maintenance facilities when the aircrew is not present is a problem and a definite deficiency.

2.4.6 Operational Advantages and Disadvantages - The pros and cons of using the ACLS in airlift operations can be reviewed in a matrix format, as shown in Table 2-5. As indicated under disadvantages, there are definite ACLS deficiencies, most important of which are the degradation of visibility under certain ground cover conditions and limitations on ground mobility. However, the ACLS, when operating over unimproved and snow covered surfaces, is far superior to CLG. One caution must be observed. The ability of the ACLS to absorb the impact force of a steep (7.5-degree) approach and a no-flare landing without structural damage is critical to its acceptance for a true STOL (2,000 feet over 50 feet) transport aircraft.

The disadvantages shown as items 1 and 4a in Table 2-5 are minor. A more lengthy and detailed checklist can be classed as an inconvenience. The fact that the ground distance used for takeoff is approximately the same for both concepts makes item 4a relatively unimportant; also it is the kind of deficiency that is solved with additional design study. Item 3b involving visibility can be largely overcome by window washing and wiping; it is the same difficulty that is faced successfully by helicopter pilots.

The offsetting penalties involve drag. Absence of the conventional gear sponsons decreases drag, but the folded trunk against the fuselage increases it. Detailed design has not progressed to the point where finite answers are available; more work on trunk folding and recessing may well result in an overall drag decrease.

The ACLS advantages when operating over unimproved surfaces are significant. Better survivability/vulnerability is important. Another advantage is better ability to handle crosswinds by making approaches, landings and taxiing is a crabbed attitude similar to that possible only with complicated and expensive crosswind CLG.

When the tactical airlift operations are seen as a system of terminals, airstrips, supply installations, vehicles, etc., the advent of the ACLS will greatly expand operational flexibility. In addition, this flexibility will be achieved at a lower system cost. Enormous savings in time, troop unit, and material costs

would accrue due to the virtual elimination of runway and taxiway construction. Access roads, parking ramps and cargo handling docks will still be needed to preserve the mobility of ground forces.

**Table 2-5. Operational Advantages and Disadvantages  
of the ACLS Compared to CLG**

FLIGHT SEGMENT	ADVANTAGES	DISADVANTAGES
1. Preflight	Omits CLG System	Adds 2 engines, ducts, trunk & associated instruments
2. Start		(Same as Item 1)
3. Taxi		
a.	Can use unimproved surfaces	Some additional control difficulties in strong cross & tailwinds.
b.		Some degradation in visibility on snow & mud covered surfaces
4. Takeoff		
a.	(Same as Item 3)	Blown stabilizer needed to rotate
b.	Takeoff run same as CLG	
c.	Handles crosswinds better	Some new control techniques must be learned
d.	Lower vulnerability to enemy fire. (See para 1, Survivability/Vulnerability)	
5. Climbout	(Same as Item 4c)	Slightly slower rate of climb
6. Enroute		Slightly increased drag, lower airspeed
7. Approach	(Same as Items 4b & 4c)	
8. Landing	(Same as Items 4b & 4c) More "forgiving" of control errors. Can accept high sink rate (15 fps, 4g) (See Figure 11) (Same as Item 3)	
9. Ground Handling	Variable cargo floor height by changing pressure of parking bladder	No ground mobility w/o main engines (or tub). Difficult to move with ACLG not activated



## SECTION 3

### POWERED LANDING GEAR

The cargo delivery capability of the aircraft can be greatly enhanced by an on-board propulsion system.

The following are the most likely candidates for transmitting power to the wheels:

#### 3.1 PNEUMATIC DRIVE — This system basically utilizes the bleed air output

capability of an APU to drive an air turbine motor (ATM). The ATM rpm is reduced by suitable gearing, with the output shaft driving a gear box incorporating a reversing gear and a clutch. This drive unit is mounted on the axle of the bogie beam and is coupled to the landing gear wheels by means of a chain drive. One disadvantage of this system is that the drive unit, being mounted on the axle or bogie beam assembly, is subjected to high acceleration loads, as well as to dust, rocks, mud, etc. Also a minimum of of four and possible eight units

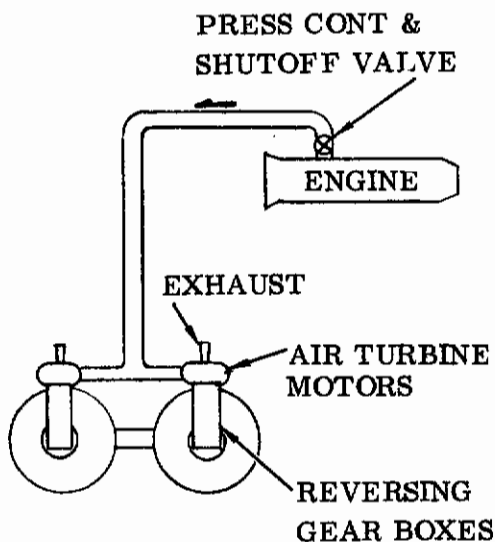

will be required to produce the necessary horsepower, resulting in reliability and maintenance problems. Another problem area is the ducting complexity of providing a means of ducting air between the fixed aircraft systems and the movable wheel system.

**3.2 PNEUMATIC/MECHANICAL** — This arrangement is similar to pneumatic

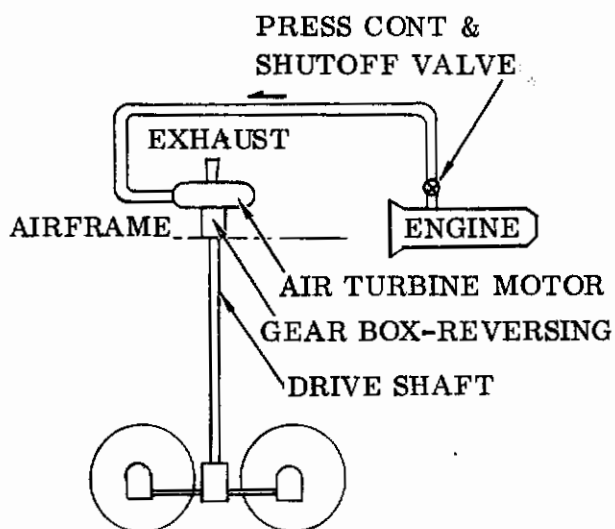

drive, except the air turbine motors and reduction-reversing gearboxes are mounted either in the wheel bay or on the landing gear strut. A telescoping or similar driveshaft transmits power to the wheels via a simple bevel gearbox in the axle. Although this system overcomes the objection of mounting equipment on the axle/bogie beam assembly and adding to the unsprung weight of the airplane, it also has problems such as the longer shafting system, with its complement of splined shafts, universal joints, and added gears.

**3.3 MECHANICAL** — The mechanical system was selected due to its basic simplicity

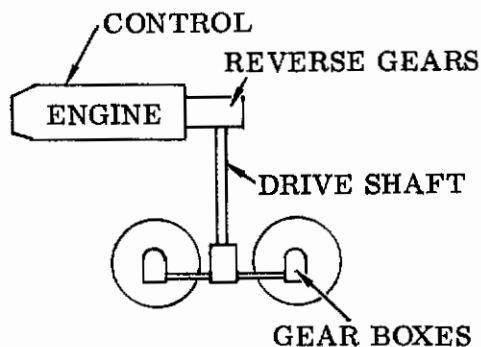

and straight-forwardness of applying external power to the wheel system. Only two gas turbine power units are required. These power units can be available in the required time period; the balance of the system, shafting, gear boxes and clutches, are well within the existing state-of-the-art. The mechanical system also incorporates inherent redundancy in that at some reduced speeds, aircraft weights,

or grade angles, only one power unit (driving four wheels) will move the aircraft.

**3.4 HYDRAULIC** — The hydraulic drive arrangement has considerable losses

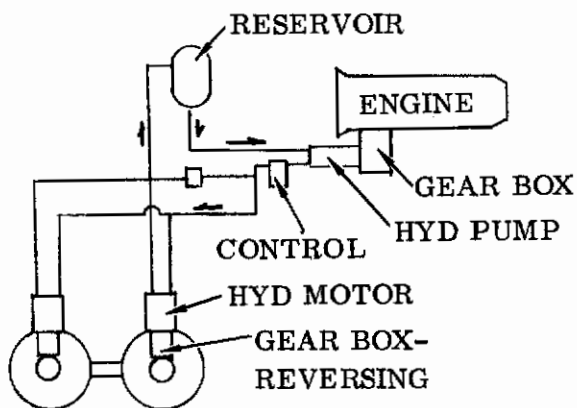

inherent in generating hydraulic power, transmitting it, and in the hydraulic motor itself. The power required to drive adequate hydraulic pumps appears prohibitive, as well as the size, number and mechanical tie-in on the hydraulic motors required to drive the wheel/axle system. Either much larger or additional APUs would be required, the weight and cost of which would eliminate this concept from further consideration.

### 3.5 ELECTRICAL - A preliminary investigation of this concept disclosed that

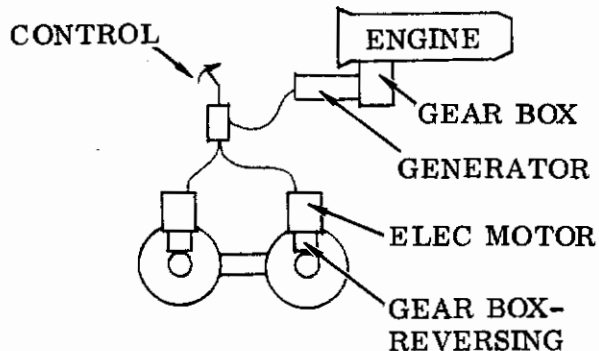

although it may be practical for much lower weight vehicles, moving a 150,000-pound airplane under the specified conditions requires more electrical power and adds more weight than considered allowable. Approximately 350 KVA of electrical power would be required to be generated by on-board APUs, and the eight 50-HP 400-cycle drive motors would weigh approximately 160 pounds each.

The following power sources are considered:

1. Installed APU - A preliminary investigation discloses that the bleed air requirements for main and blowing engine starting and for the environmental control system (including avionic equipment cooling) is considerably lower than the air required to drive at least four 100-HP air turbine motors to move the aircraft at the desired performance. An additional APU would be required which would add at least 300 pounds to the aircraft.

An alternative solution would be to add bleed air reheat capability to each of the present APUs. By adding energy to the air in the form of heat, and using a suitable high temperature air motor at the wheel drive end, adequate power appears available without adding additional units. Ducting the air, especially the reheat air, is considered the major problem of this concept. Suitable flexible sections would be required to bridge the landing gear strut, and the routing and space problem of installing at least two air turbine motors and their respective ducting adjacent to the wheel/axle would be of major proportions.

2. Blowing Engines - If the aircraft configuration incorporates blowing engines for the control surfaces, flaps, etc., this air source may be used to provide air-to-air turbine motors at the wheel/axle assembly. Disadvantages include: cost of operation, high noise levels, and wearing out engines required for very critical flight conditions during takeoff and landing.

3. **Independent Power Source** — This concept makes the ground mobility system completely independent of other sources of aircraft generated power.

The mechanical drive was selected and the design is shown in Figure 3-1. The power is furnished by two Solar T62T-40 gas turbine auxiliary power units mounted on the main landing gear struts.

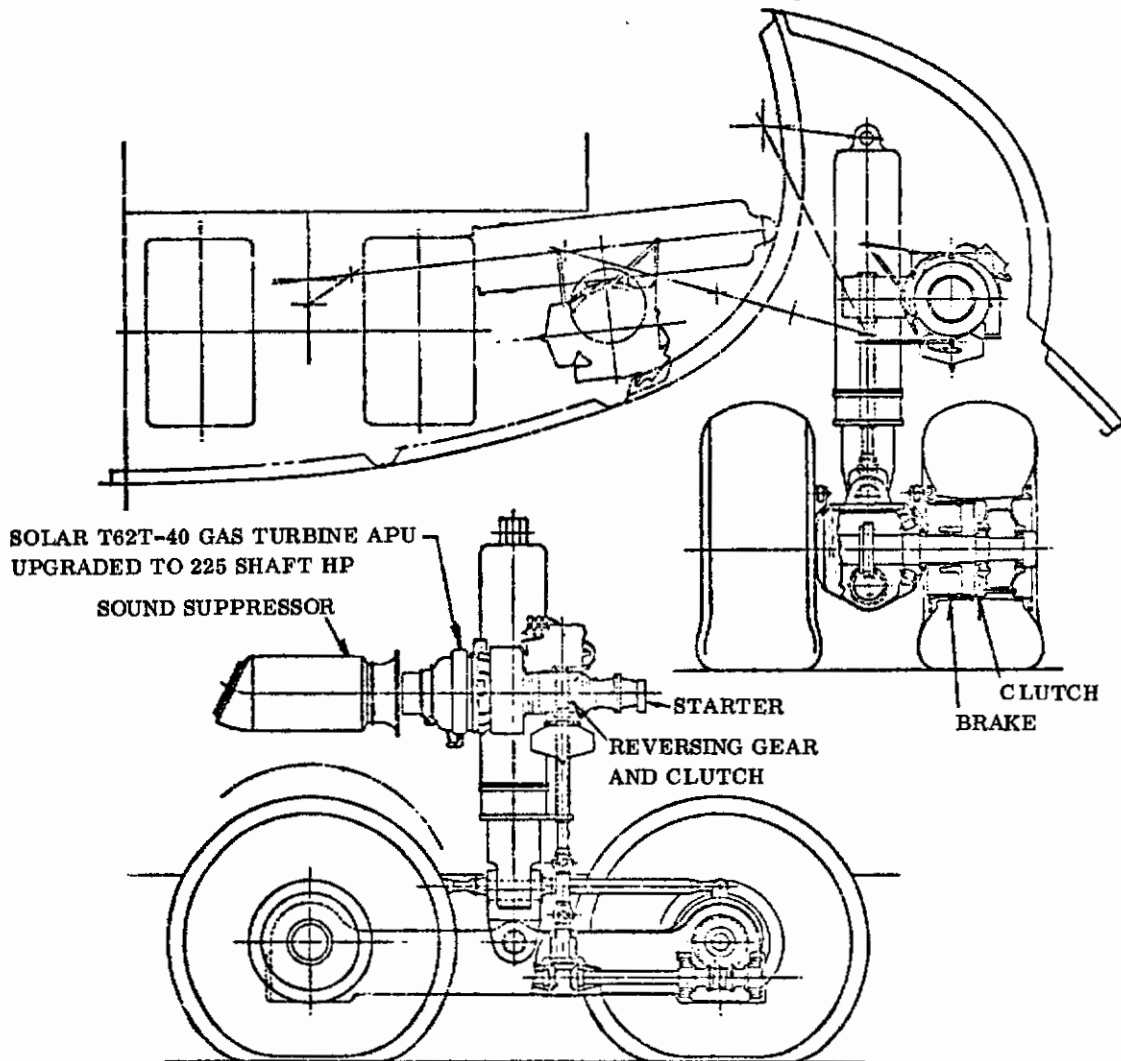
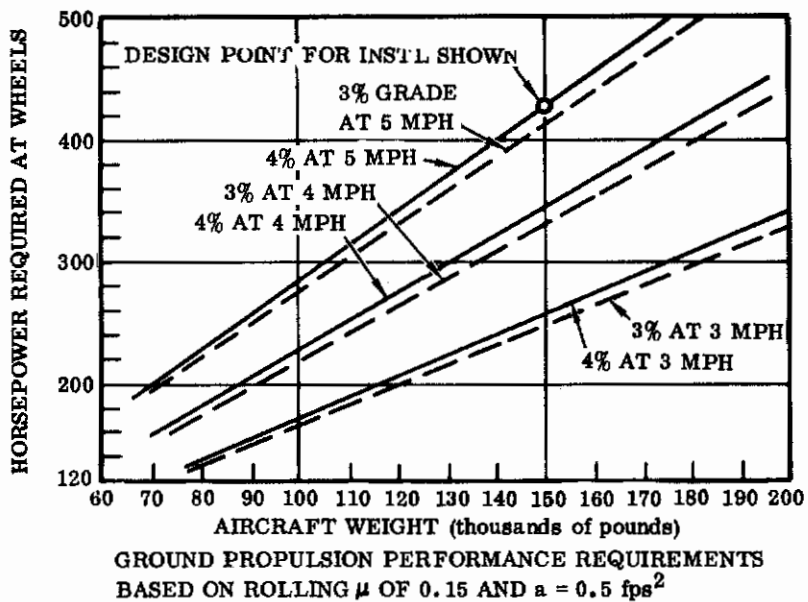

Figure 3-1. Powered Landing Gear Configuration

# *Contrails*

## SECTION 4

### CONCLUSIONS AND RECOMMENDATIONS

The available data on Air Cushion Landing System characteristics have been applied to design of an MST aircraft with ACLS (Figure 2-1). Both "hard" ( $p_c/p_j = 0.5$ ) and "soft" ( $p_c/p_j = 0.8$ ) bag designs have been analyzed and the following characteristics noted:

1. The soft-bag design requires 8 percent lower air flow and 45 percent less fan power than the hard-bag design.
2. The hard-bag design allows 20 percent higher sink speed than the soft-bag design for the same bag deflection.
3. Obstacle height which can be negotiated by ACLS is 80 percent greater for the hard-bag configuration.
4. Terrain performance over transverse furrows is 45 percent greater for the hard-bag configuration.

Using the hard-bag configuration, operating weight (empty) for the ACLS is 1,908 pounds less than the high flotation wheeled gear. Operational analysis considerations other than additional maintenance required indicate superior tactical STOL transport characteristics with ACLS. The potential advantages of the ACLS appear to be overriding when compared to CLG. Careful analysis and further testing are needed to assure that the impact forces generated by steep approaches, and no-flare landings by the MST, can be absorbed by the ACLS without difficulty.

A ground mobility system has been sized for the MST to negotiate a 4 percent grade at 5 mph. The configuration includes a turboshaft APU for each bogie sized at 225 SHP driving the wheels through reversing gear, clutch, and shafting. Estimated weight increment for this configuration is 843 pounds.

The following recommendations are made:

1. The Air Cushion Landing System should be given strong consideration in designing MST aircraft for unprepared field operation.
2. Further study, model testing and development should be devoted to:
  - a. Means of retracting trunk into a "clean" aerodynamic shape.
  - b. Interactions of flap blowing streams and ACLS system in ground effect.
  - c. The ejector air supply system as a simpler, lighter method of trunk pressurization.
  - d. Trade-off of hard vs soft bag characteristics.
3. The mechanically driven, powered landing gear system warrants further operational analysis and design study as an effective means of providing ground mobility.



SECTION 5  
REFERENCES

1. Digges, K. H., Theory of an Air Cushion Landing System for Aircraft, AFFDL-TR-71-50, June 1971.
2. Stauffer, C. L., Water Operations and Overland Braking Test Report of Air Cushion Landing System (LA-4). AFFDL-TR-69-125, April 1970.
3. Stauffer, C. L., Ground/Flight Test Report of Air Cushion Landing Gear (LA-4). AFFDL-TR-69-23.
4. Digges, K. H., Perez, D. J., Air Cushion Landing System for STOL Aircraft, Technical Paper AFFDL V/STOL Technology and Planning Conference, 25 September 1969.
5. Earl, Desmond T., Cooper, Richard H., Air Cushion Landing Gear for Aircraft. AFFDL-TR-68-124, January 1969.
6. Earl, Desmond T., Air Cushion Landing Gear Feasibility Study, AFFDL-TR-67-32, May 1967.
7. Wan, Chia-An, A Study of Jet Ejector Phenomena. Research Report No. 57, Mississippi State University, November 1964.

# *Contrails*

Unclassified  
Security Classification

DOCUMENT CONTROL DATA - R & D		
<i>(Security classification of title, body of abstract and indexing annotation must be entered when the overall report is classified)</i>		
1. ORIGINATING ACTIVITY (Corporate author) Convair Aerospace Division General Dynamics Corporation San Diego, California 92138		2a. REPORT SECURITY CLASSIFICATION <b>Unclassified</b>
3. REPORT TITLE STOL Tactical Aircraft Investigation Volume VI - Air Cushion And Ground Mobility Study		2b. GROUP
4. DESCRIPTIVE NOTES (Type of report and inclusive dates) <b>Final Report (7 June 1971 to 31 January 1973)</b>		
5. AUTHOR(S) (First name, middle initial, last name) J. Hebert, Jr., H. Weber, G. T. Draper, C. Kerr, Jr., T. F. Reid		
6. REPORT DATE <b>May 1973</b>	7a. TOTAL NO. OF PAGES <b>36</b>	7b. NO. OF REFS <b>7</b>
8a. CONTRACT OR GRANT NO. <b>F33615-71-C-1754</b>	9a. ORIGINATOR'S REPORT NUMBER(S) <b>GDCA-DHG73-001</b>	
b. PROJECT NO. <b>643A - Task 0001</b>	9b. OTHER REPORT NO(S) (Any other numbers that may be assigned this report) <b>AFFDL TR-73-21-Vol V</b>	
10. DISTRIBUTION STATEMENT <b>Approved for Public Release Distribution Unlimited</b>		
11. SUPPLEMENTARY NOTES ----	12. SPONSORING MILITARY ACTIVITY <b>Air Force Flight Dynamics Laboratory (PTA) Wright Patterson AFB, Ohio 45433</b>	
13. ABSTRACT The Tactical STOL transport design must consider forms of high flotation landing gear to operate effectively from unprepared fields. One configuration of particular interest is the Air Cushion Landing System (ACLS) which utilizes the ground effect principle to reduce ground overpressures. This system has been designed for the MST based on Air Force Flight Dynamics Laboratory development experience on model and full scale testing of the LA-4. The configuration includes a rubber-nylon, torus-shaped trunk attached to the lower portion of the fuselage. Air is supplied to the trunk by turboshaft-driven fans. It is then exhausted through rows of holes along the trunk ground tangent. Aircraft weight is distributed over the cushion area providing the desired low ground pressure. After liftoff, the trunk is deflated and retracts into the side of fuselage by elastic action of the trunk material. Braking is accomplished by expanding inflatable pillows against the ground and bleeding off cushion pressure.  The cargo delivery/loading capability of the MST can be greatly expedited by incorporating an onboard ground mobility system in conjunction with conventional landing gear. After viewing various wheel drive systems (pneumatic, electrical, hydraulic), a mechanical drive system is presented. A gas turbine APU is mounted to the shock strut over each bogie, driving the wheels through reversing gear, clutch and shafting.		

# Contrails

Security Classification						
14. KEY WORDS	LINK A		LINK B		LINK C	
	ROLE	WT	ROLE	WT	ROLE	WT
1. Air Cushion Landing System 2. Externally Blown Flaps 3. Mechanical Design 4. Ground Propulsion						